



TESTING CERT #3478.01



# TEST REPORT

EUT Description	WiGig, WLAN and BT, 2x2 PCIe M.2 2230 adapter card
Brand Name	Intel® Tri-Band Wireless-AC 18265
Model Name	1865NGW, 18265NGW LC
Serial Number	TA#: J30458-002 WFM: 34:13:E8:34:53:E4 / 34:13:E8:44:A8:B2 / 34:13:E8:44:CF:34 BDM: 34:13:E8:34:53:E8 / 34:13:E8:44:A8:B6 / 34:13:E8:34:54:9C (see section 4)
FCC ID / IC ID	FCC ID: PD918265NG / IC ID: 1000M-18265NG
Antenna type	Universe Technology
Hardware/Software Version	HW cfg:33.10 Test SW : DRTU version 03789_1_9_0G (driver version: 19.1.0.1) and DRTU version 03293_1_8_9G (driver version: 19.1.0.1)
Date of Sample Receipt	2016-08-30
Date of Test Start/End	2016-09-07 / 2016-10-28
Features	WiGig + 802.11 a/b/g/n/ac Wireless LAN + BDR/EDR 2.1 + BLE 4.2 (see section 5)

Applicant	Intel Mobile Communications
Address	100 Center Point Circle, Suite 200 Columbia, South Carolina 29210 USA
Contact Person	Steven Hackett
Telephone/Fax/ Email	steven.c.hackett@intel.com

Reference Standards	FCC CFR Title 47 Part 15E RSS-247 issue 1, RSS-Gen issue 4 (see section 1)
---------------------	--

Test Report number	160830-01.TR02
Revision Control	Rev.00

The test results relate only to the samples tested.  
The test report shall not be reproduced in full, without written approval of the laboratory.

Issued by \_\_\_\_\_ Reviewed by \_\_\_\_\_

Walid El Hajj  
(RF Test Lead)

Olivier FARGANT  
(Technical Manager)

# Table of Contents

---

<b>1. Standards, reference documents and applicable test methods .....</b>	<b>3</b>
<b>2. General conditions, competences and guarantees .....</b>	<b>3</b>
<b>3. Environmental Conditions .....</b>	<b>3</b>
<b>4. Test samples .....</b>	<b>4</b>
<b>5. EUT features .....</b>	<b>5</b>
<b>6. Remarks and comments .....</b>	<b>5</b>
<b>7. Test Verdicts summary .....</b>	<b>5</b>
7.1. 802.11 A/N/AC – U-NII-2C.....	5
<b>8. Document Revision History .....</b>	<b>5</b>
<b>Annex A. Test &amp; System Description .....</b>	<b>6</b>
A.1 TEST CONDITIONS .....	6
A.2 MEASUREMENT SYSTEM.....	7
A.3 TEST EQUIPMENT LIST .....	9
A.4 MEASUREMENT UNCERTAINTY EVALUATION .....	10
<b>Annex B. Test Results U-NII-2C .....</b>	<b>11</b>
B.1 26dB & 99% BANDWIDTH .....	11
B.2 POWER LIMITS. MAXIMUM OUTPUT POWER & PEAK POWER SPECTRAL DENSITY.....	64
B.3 UNDESIRABLE EMISSIONS LIMITS: BAND EDGE (CONDUCTED) .....	96
B.4 RADIATED SPURIOUS EMISSION .....	126
<b>Annex C. Photographs .....</b>	<b>158</b>

## 1. Standards, reference documents and applicable test methods

1. FCC 47 CFR part 15 – Subpart E – Unlicensed National Information Infrastructure Devices.
2. FCC 47 CFR part 15 - Subpart C – §15.209 Radiated emission limits; general requirements.
3. FCC OET KDB 789033 D02 General UNII Test Procedures New Rules – Guidelines for compliance testing of Unlicensed National Information Infrastructure (U-NII) Devices.
4. FCC OET KDB 644545 D03 Guidance for IEEE 802.11ac v01 - GUIDANCE FOR IEEE Std 802.11ac™ DEVICES EMISSION TESTING.
5. ANSI C63.10-2013 American National Standard of Procedures for Compliance Testing of Unlicensed Wireless Devices.
6. RSS-247 Issue 1 - Digital Transmission Systems (DTSs), Frequency Hopping Systems (FHSs) and Licence-Exempt Local Area Network (LE-LAN) Devices.
7. RSS-Gen Issue 4 - General Requirements for Compliance of Radio Apparatus.

## 2. General conditions, competences and guarantees

- ✓ Intel Mobile Communications Wireless RF Lab (Intel WRF Lab) is a testing laboratory accredited by the American Association for Laboratory Accreditation (A2LA).
- ✓ Intel Mobile Communications Wireless RF Lab (Intel WRF Lab) is an Accredited Test Firm listed by the FCC, with Designation Number FR0011.
- ✓ Intel Mobile Communications Wireless RF Lab (Intel WRF Lab) is a Registered Test Site listed by IC, with IC Assigned Code 1000Y.
- ✓ Intel WRF Lab only provides testing services and is committed to providing reliable, unbiased test results and interpretations.
- ✓ Intel WRF Lab is liable to the client for the maintenance of the confidentiality of all information related to the item under test and the results of the test.
- ✓ Intel WRF Lab has developed calibration and proficiency programs for its measurement equipment to ensure correlated and reliable results to its customers.
- ✓ This report is only referred to the item that has undergone the test.
- ✓ This report does not imply an approval of the product by the Certification Bodies or competent Authorities.
- ✓ Complete or partial reproduction of the report cannot be made without written permission of Intel WRF Lab.

## 3. Environmental Conditions

- ✓ At the site where the measurements were performed the following limits were not exceeded during the tests:

Temperature	22.5 °C ± 4 °C
Humidity	50 % ± 20 %

#### 4. Test samples

Sample	Control #	Description	Model	Serial #	Date of reception	Note
#01	160830-01.S05	WiGig / WiFi / BT Module	18265NGW	WFM: 34:13:E8:34:53:E4 BDM: 34:13:E8:34:53:E8	2016-08-30	Used for conducted tests
	15081801.S05	Extender board	PCB00469	4694213-0134	2016-08-30	
	160107-01.S18	AC/DC Adapter	SPU60-102	08741164 1350	2016-01-07	
	160107-01.S15	Laptop	DELL Latitude	4Z2YG12	2016-01-07	
#02	160830-01.S06	WiGig / WiFi / BT Module	18265NGW	WFM: 34:13:E8:44:A8:B2 BDM: 34:13:E8:44:A8:B6	2016-08-30	Used for radiated tests (from 30MHz to 1GHz and 18GHz to 40GHz) and For 802.n20 CH120, CH140 Chain B from 6.4 GHz to 18 GHz
	160830-01.S38	Extender board	PCB00469	ASS00469-001 4694213-099	2016-09-27	
	15051101.S09	Laptop	DELL E5440	9FSYN32	2015-05-12	
#03	160830-01.S11	WiGig / WiFi / BT Module	18265NGW	WFM: 34:13:E8:44:CF:34 BDM: 34:13:E8:34:54:9C	2016-08-30	Used for radiated tests (from 1GHz to 18GHz) except the cases indicated in sample #02 note
	160830-01.S21	Extender Rev-2	PCB00469	4694213-245	2016-09-02	
	160202-02.S29	Control Laptop	Dell Latitude E6430	D41QVY1	2016-03-18	
	160202-02.S19	Extender board	PCB00284	ASS0248 2480614-071	2016-02-10	
	160202-02.S20	Express Card Adapter	Not available	600010757	2016-02-12	

NA: Not Applicable

## 5. EUT features

These are the detailed bands and modes supported by the Equipment Under Test:

WiGig	60GHz (57.24 – 63.72 GHz)
802.11b/g/n	2.4GHz (2400.0 – 2483.5 MHz)
802.11a/n/ac	5.2GHz (5150.0 – 5250.0 MHz) 5.3GHz (5250.0 – 5350.0 MHz) 5.6GHz (5470.0 – 5725.0 MHz) 5.8GHz (5725.0 – 5850.0 MHz)
BDR/EDR/BLE 4.2	2.4GHz (2400.0 – 2483.5 MHz)

## 6. Remarks and comments

N/A

## 7. Test Verdicts summary

### 7.1. 802.11 a/n/ac – U-NII-2C

FCC part	RSS part	Test name	Verdict
15.407 (a) (2)	RSS-247 Clause 6.2.3 (1)	Power Limits. Maximum output power	P
15.407 (a) (2)	RSS-247 Clause 6.2.3 (1)	Peak power spectral density	P
15.407 (b) (3) 15.209	RSS-247 Clause 6.2.3 (2)	Undesirable emissions limits: Band Edge (conducted)	P
15.407 (b) (3) 15.209	RSS-247 Clause 6.2.3 (2)	Undesirable emissions limits (radiated)	P

P: Pass  
F: Fail  
NM: Not Measured  
NA: Not Applicable

## 8. Document Revision History

Revision #	Date	Modified by	Details
Rev. 00	2016-10-28	E.GARCIA I.KHARRAT	First Issue

# Annex A. Test & System Description

## A.1 Test Conditions

For 802.11a mode the EUT can transmit at both CHAIN A and CHAIN B RF outputs individually, but not simultaneously.

For 802.11n20 (20 MHz channel bandwidth), 802.11n40 (40MHz channel bandwidth) and 802.11ac80 (80MHz channel bandwidth) modes the EUT can transmit at both CHAIN A and CHAIN B RF outputs individually, and also simultaneously.

The conducted RF output power at chain A was adjusted according to the client’s supplied Target values (see following table) using the Intel DRTU tool and measuring the power by using a spectrum analyzer with the channel integration method according to point II) E) 2) e) (Method SA-2 Alternative) of Guidance 789033 D02.

Measured values for adjustment were within -0.25 dB/+0.25 dB from the declared Target values.

U-NII-2C					Conducted Power, Target Value (dBm)		
Mode	BW (MHz)	Data Rate	CH #	Freq. (MHz)	SISO Chain A	SISO Chain B	MIMO at both ports A and B
802.11a	20	6Mbps	100	5500	17.0	17.5	N/A
			120	5600	20.0	20.0	N/A
			140	5700	18.5	17.0	N/A
802.11n	20	HT0 HT8*	100	5500	17.0	17.5	15.0
			120	5600	21.0	20.5	18.0
			140	5700	18.5	17.0	14.5
	40	HT0 HT8*	102F	5510	15.5	14.0	13.5
			118F	5590	21.0	20.5	21.0
			134F	5670	18.0	17.5	16.5
802.11ac	80	VHT0	106ac80	5530	14.0	13.5	12.5
			122ac80	5610	19.0	19.5	17.5

Overlapped channels between UNII-2C and UNII-3					Conducted Power, Target Value (dBm)		
Mode	BW (MHz)	Data Rate	CH #	Freq. (MHz)	SISO Chain A	SISO Chain B	MIMO at both ports A and B
802.11n	20	HT0 HT8*	144	5720	20.5	20.5	19.5
	40	HT0 HT8*	142F	5710	20.5	20.5	20.5
802.11ac	80	VHT0	138ac80	5690	20	20	20

The following data rates were selected based on preliminary testing that identified those rates as the worst cases for output power and spurious levels at the band edges:

- 802.11a → 6Mbps
- 802.11n20 and 802.11n40 (SISO) → HT0
- 802.11n20 and 802.11n40 (MIMO) → HT8
- 802.11ac80 (SISO) → VHT0
- 802.11ac80 (MIMO) → VHT0

Alternative channels to the lowest and highest channels per band have been also tested for Band Edge compliance.

## A.2 Measurement system

Measurements were performed using the following setups, made in accordance to the general provisions of FCC KDB 789033 D02 General UNII Test Procedures.

The DUT was installed in a test fixture and this test fixture is connected to a laptop computer and AC/DC power adapter. The laptop computer was used to configure the EUT to continuously transmit at a specified output power using all different modes and modulation schemes, using the Intel proprietary tool DRTU.

### Conducted Setup

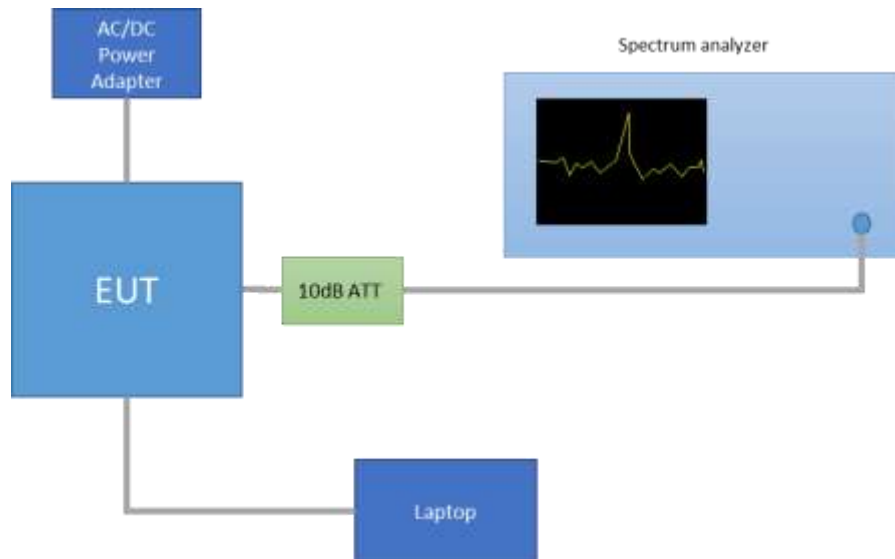

### Radiated Setup < 1GHz

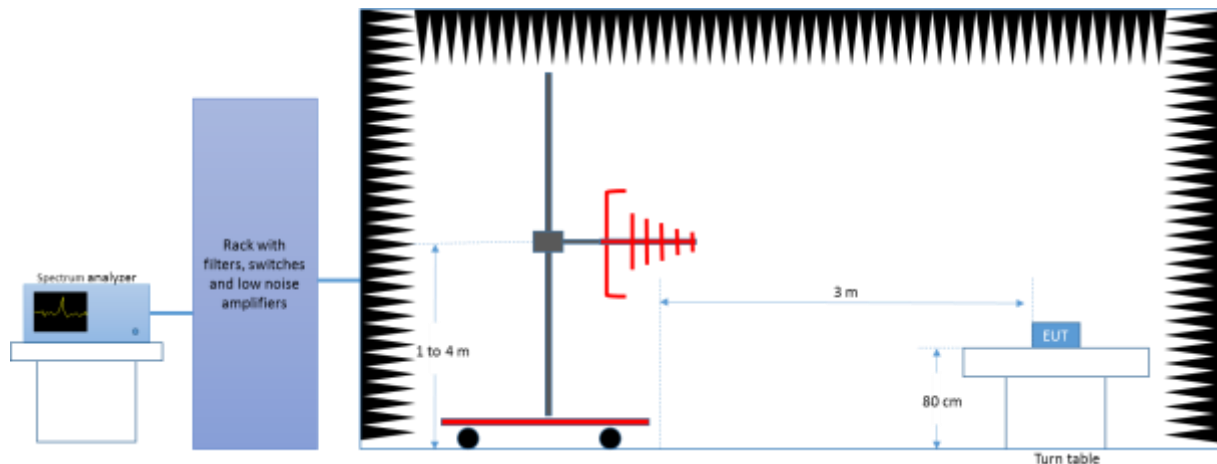

*Radiated Setup 1 GHz - 18 GHz*

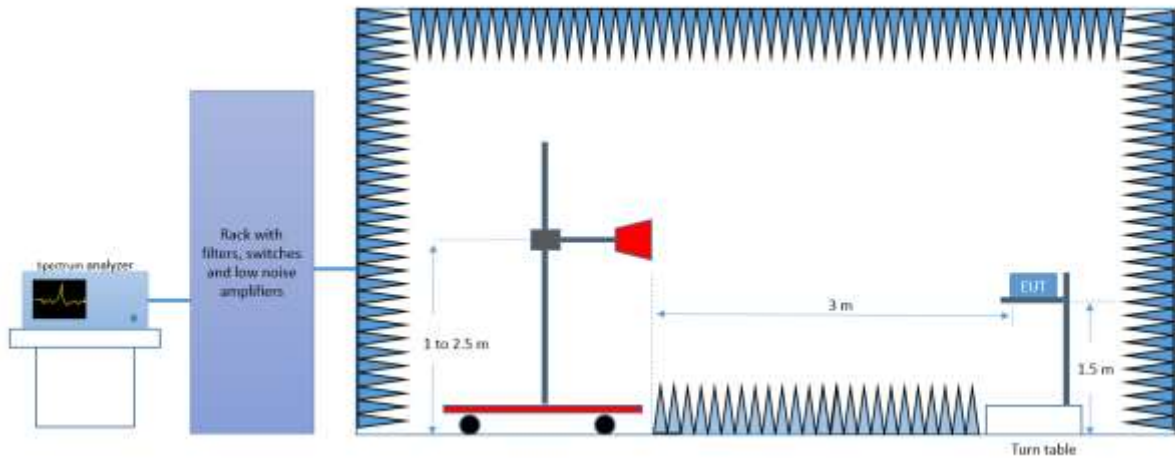

*Radiated Setup 18 GHz - 26.5 GHz*

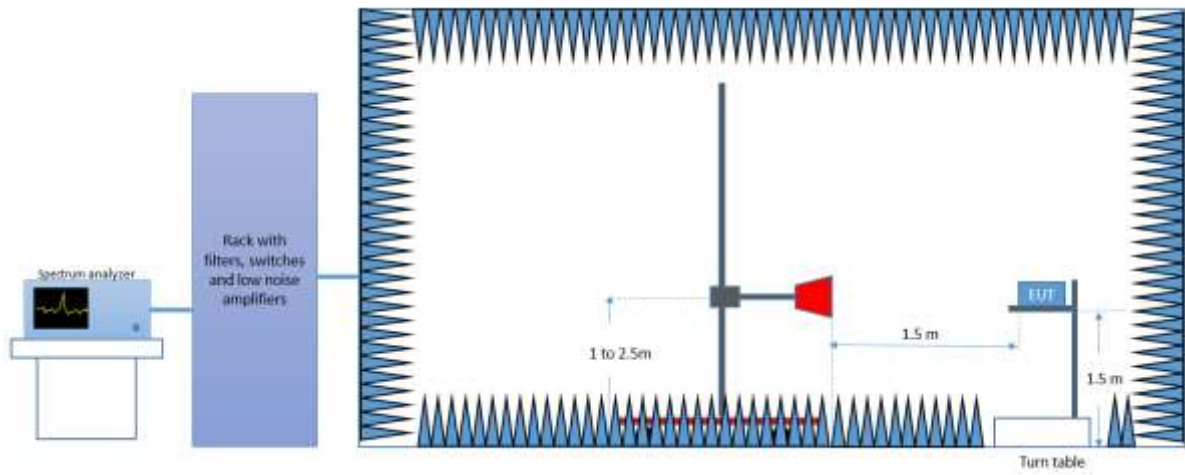

*Radiated Setup > 26.5 GHz*

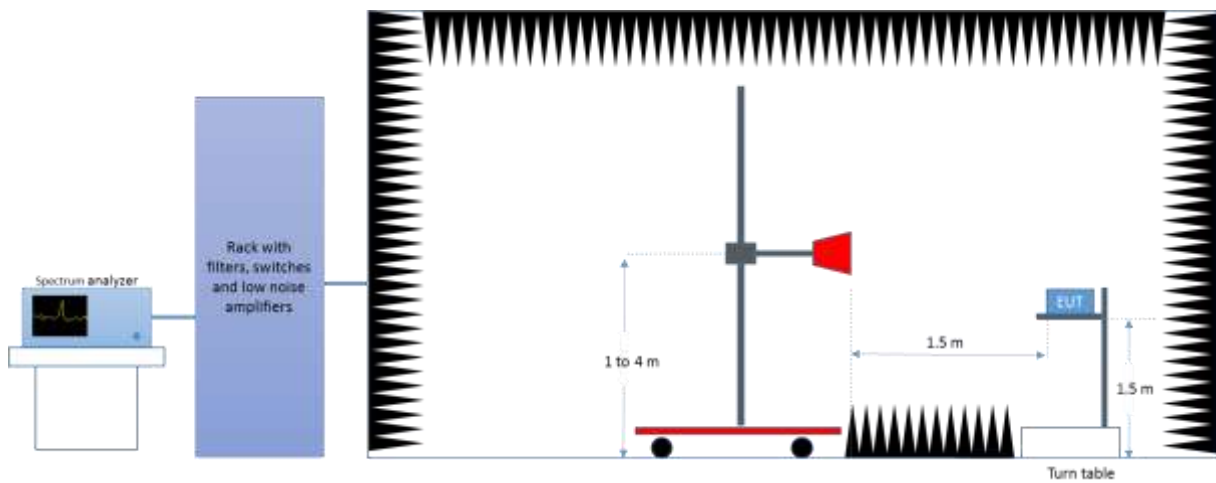



### A.3 Test Equipment List

#### Conducted Setup

ID#	Device	Type/Model	Serial Number	Manufacturer	Cal. Date	Cal. Due Date
0316	Spectrum Analyser	FSV30	103309	Rohde & Schwarz	2015-03-20	2017-03-20

#### Radiated Setup

ID#	Device	Type/Model	Serial Number	Manufacturer	Cal. Date	Cal. Due Date
0420	Spectrum analyzer	FSV40	101556	Rohde & Schwarz	2016-04-15	2018-04-15
0133	Spectrum analyzer	FSV40	101358	Rohde & Schwarz	2016-04-15	2018-04-15
0137	Log antenna 30 MHz – 1 GHz	3142E	00156946	ETS Lindgren	2015-12-11	2017-12-11
0138	Horn antenna 1 GHz – 6.4 GHz	3117	00152266	ETS Lindgren	2016-03-14	2018-03-14
0248	Double Ridge Antenna with preamplifier 1 GHz – 18 GHz	3117	00167062	ETS Lindgren	2016-07-26	2018-07-26
0141	Double Ridge Horn Antenna 1 GHz – 18 GHz	3117	00157736	ETS Lindgren	2016-04-13	2018-04-13
0409	Pre-Amplifier	3117-PA	00157993	ETS Lindgren	N/A	N/A
0139	Horn Antenna 18 GHz - 26.5 GHz	114514	00167100	ETS Lindgren	2016-03-16	2018-03-16
0140	Horn Antenna 26.5 GHz – 40 GHz	120722	00169638	ETS Lindgren	2016-07-26	2018-07-26
0135	Semi Anechoic chamber	FACT 3	5720	ETS Lindgren	2016-04-28	2018-04-28
0337	Full Anechoic chamber	RFD_FA_100	5996	ETS Lindgren	2016-04-28	2018-04-28
0329	Measurement Software	EMC32	1300.7027.00 (100401)	Rohde & Schwarz	N/A	N/A
0530	Measurement Software	EMC32	100623	Rohde & Schwarz	N/A	N/A
0296	Power Supply	6673A	MY41000318	Agilent	N/A	N/A
0346	Multimeter	34401A	US36054685	HP	2016-02-04	2018-02-04
0038	Power Meter	ML2487B	952010	ANRITSU	2015-09-24	2017-09-24

#### A.4 Measurement Uncertainty Evaluation

The system uncertainty evaluation is shown in the below table:

Measurement type	Uncertainty [ ±dB]
Conducted Power	±1.0
Conducted Spurious Emission	±2.9
Radiated tests <1GHz	±3.8
Radiated tests 1GHz - 40 GHz	±4.7

# Annex B. Test Results U-NII-2C

---

## B.1 26dB & 99% Bandwidth

### Test procedure:

The setup below was used to measure the 26dB & 99% Bandwidth. The antenna terminal of the EUT is connected to the spectrum analyzer through an attenuator, and the spectrum analyzer reading is compensated to include the RF path loss.

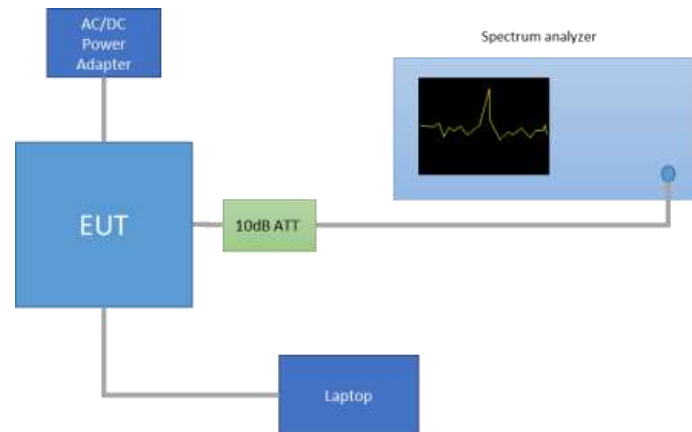

For the overlapped channels between U-NII-2C and U-NII-3 bands, and according to FCC KDB 644545 D03, the boundary frequency between the bands is used as one edge for defining the portion of the 26dB bandwidth that falls within a particular U-NII band. This rule is only applicable for the 26dB bandwidth and for those channels marked as overlapped.

**Results tables:**

**U-NII-2C channels:**

Mode	Rate	Antenna	Channel	Freq. [MHz]	26dB BW [MHz]	99% BW [MHz]
802.11a	6Mbps	SISO CHAIN A	100	5500	23.15	16.56
			120	5600	28.00	17.20
			140	5700	23.55	16.60
		SISO CHAIN B	100	5500	23.80	16.56
			120	5600	27.15	17.16
			140	5700	23.85	16.56
802.11n20	HT0	SISO CHAIN A	100	5500	23.85	17.68
			120	5600	35.30	22.08
			140	5700	24.30	17.72
		SISO CHAIN B	100	5500	23.70	17.64
			120	5600	29.85	18.44
			140	5700	24.00	17.72
	HT8	MIMO CHAIN A	100	5500	24.75	17.76
			120	5600	24.00	17.72
			140	5700	24.40	17.72
		MIMO CHAIN B	100	5500	23.50	17.64
			120	5600	23.95	17.76
			140	5700	23.15	17.68
802.11n40	HT0	SISO CHAIN A	102F	36.40	45.90	36.40
			118F	36.88	52.20	36.88
			134F	36.32	45.36	36.32
		SISO CHAIN B	102F	5510	45.18	36.24
			118F	5590	53.37	37.20
			134F	5670	44.82	36.32
	HT8	MIMO CHAIN A	102F	5510	46.62	36.40
			118F	5590	49.95	36.80
			134F	5670	46.62	36.40
		MIMO CHAIN B	102F	5510	43.56	36.16
			118F	5590	60.84	37.12
			134F	5670	43.56	36.08
802.11ac80	VHT0	SISO CHAIN A	106ac80	5530	86.26	75.00
			122ac80	5610	85.12	75.00
		SISO CHAIN B	106ac80	5530	85.31	74.88
			122ac80	5610	88.73	75.12
		MIMO CHAIN A	106ac80	5530	86.26	75.00
			122ac80	5610	86.45	75.00
		MIMO CHAIN B	106ac80	5530	84.36	74.88
			122ac80	5610	84.55	74.88

Max Value

**Overlapped channels between U-NII-2C and U-NII-3**

Mode	Rate	Antenna	Channel	Freq. [MHz]	26dB BW UNII-2C [MHz]
802.11n20	HT0	SISO CHAIN A	144	5720	19.22
		SISO CHAIN B			18.47
	HT8	MIMO CHAIN A			19.12
		MIMO CHAIN B			18.37
802.11n40	HT0	SISO CHAIN A	142F	5710	37.81
		SISO CHAIN B			42.94
	HT8	MIMO CHAIN A			40.06
		MIMO CHAIN B			37.63
802.11ac80	VHT0	SISO CHAIN A	138ac80	5690	77.27
		SISO CHAIN B			79.74
		MIMO CHAIN A			77.84
		MIMO CHAIN B			79.17

**Max Value**

**Results screenshot**

**802.11a, 6Mbps – Chain A**

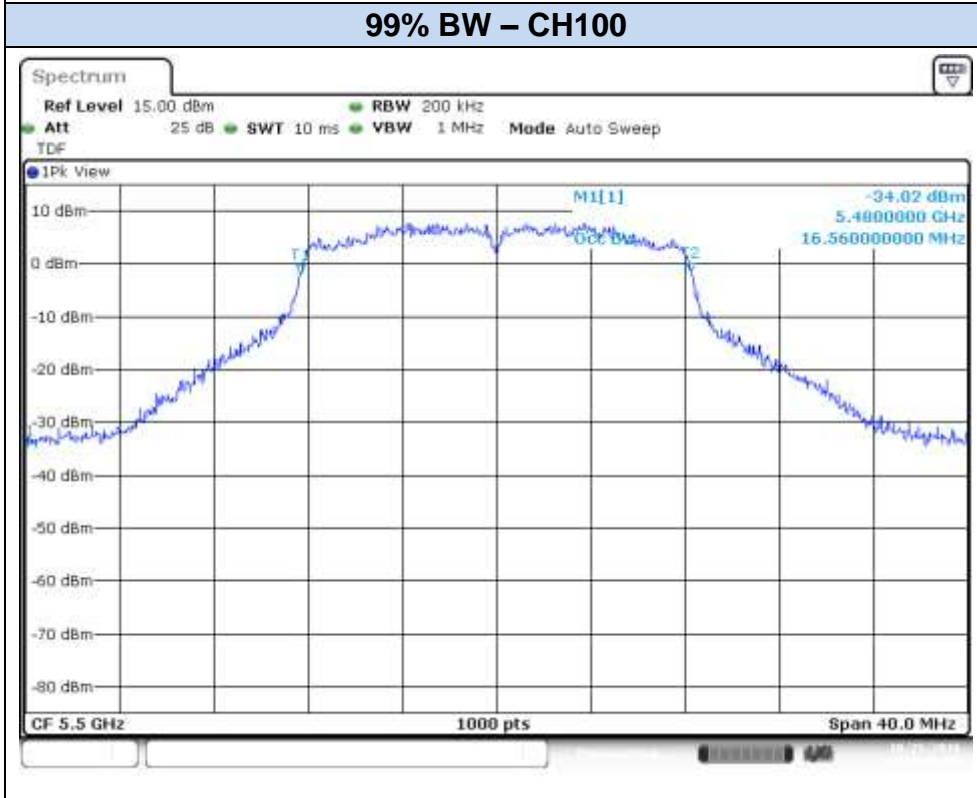
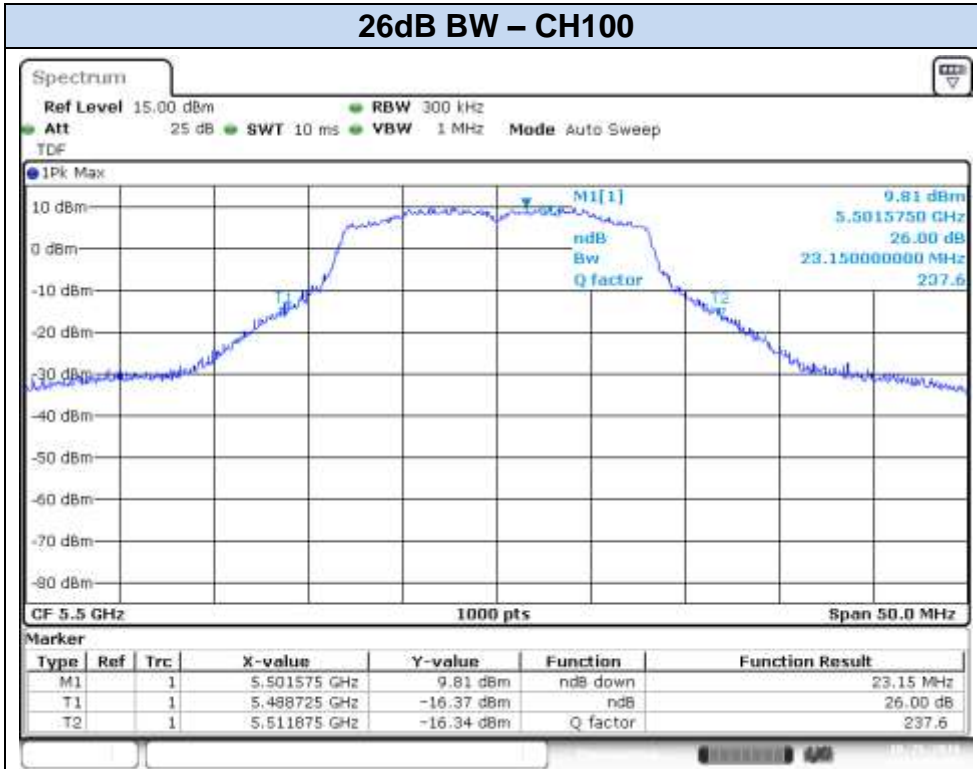

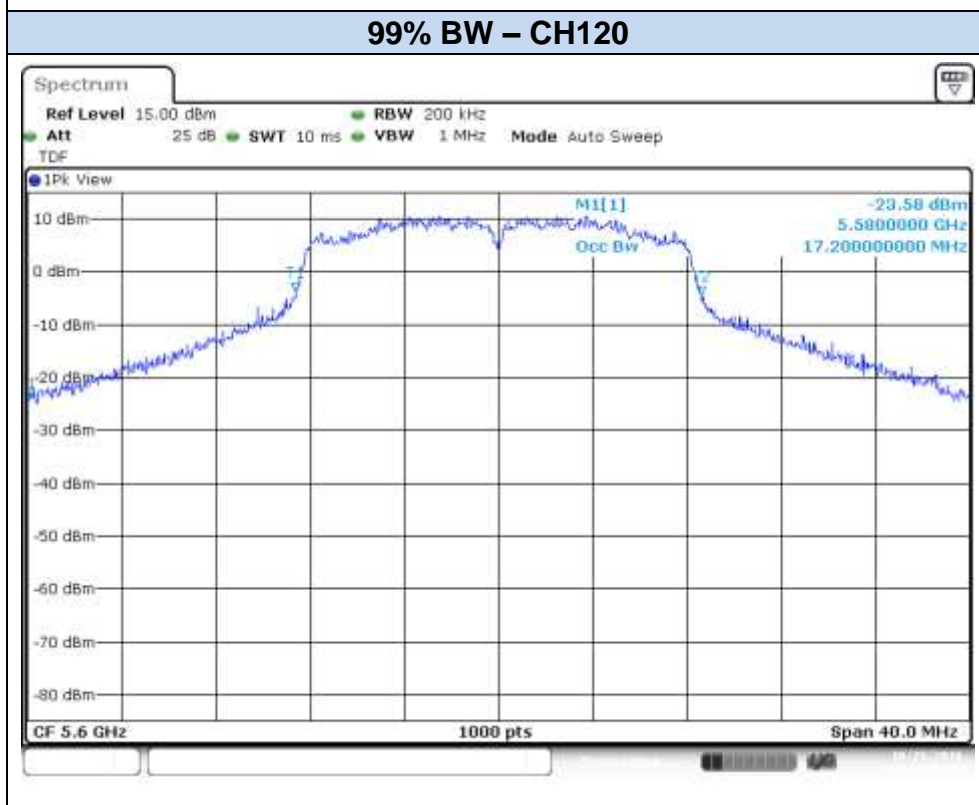
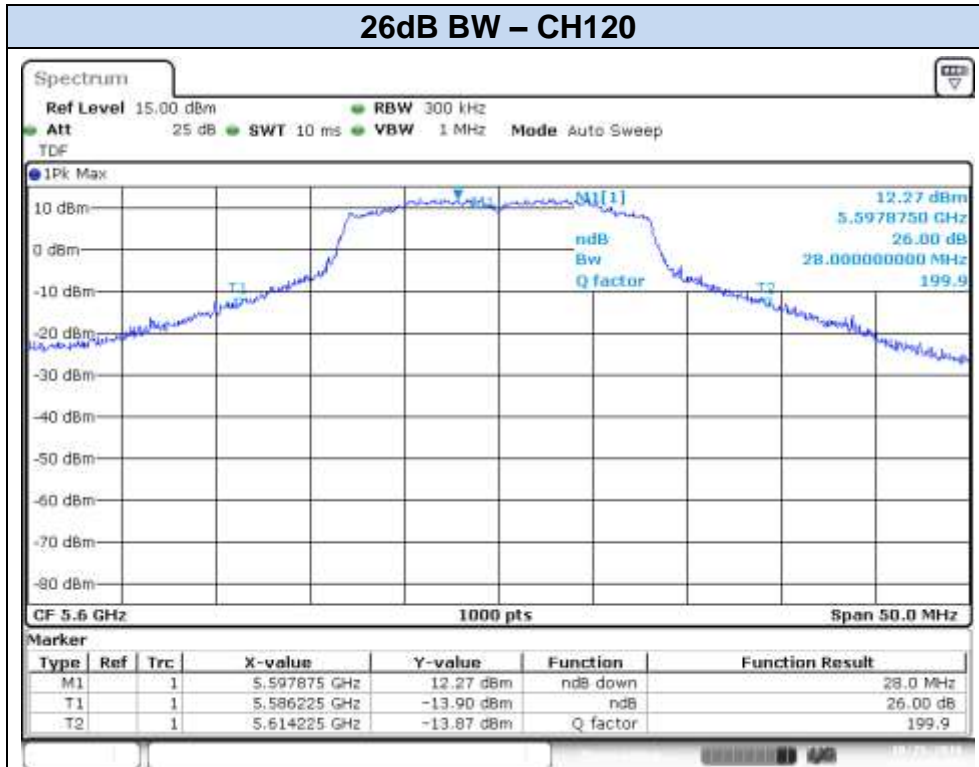

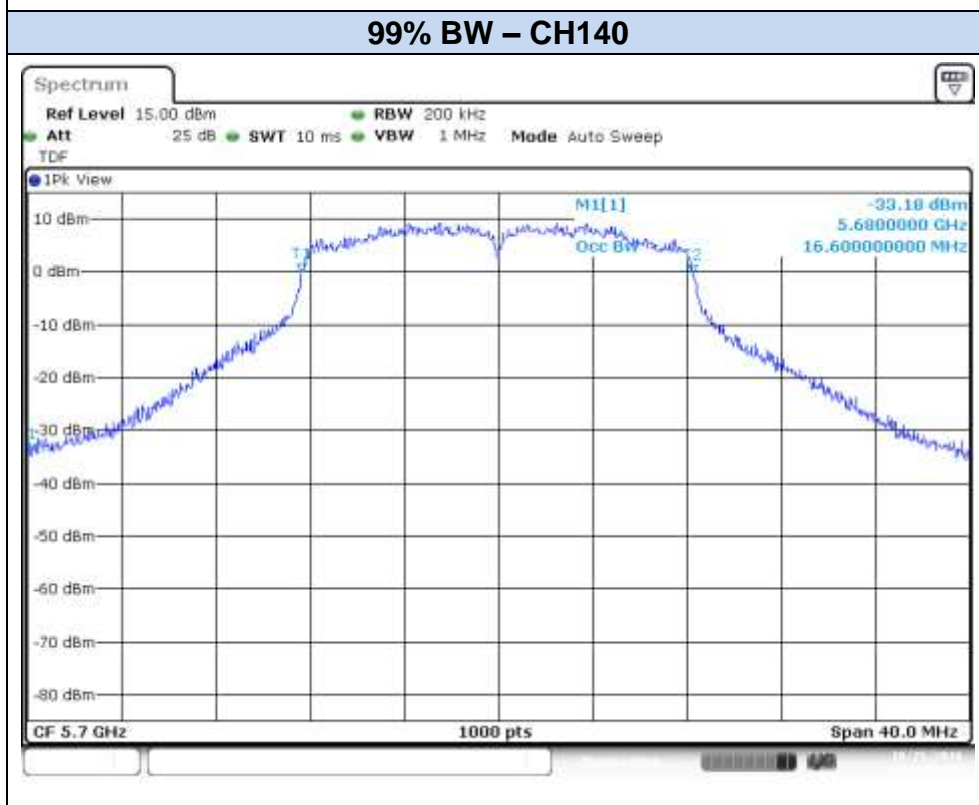
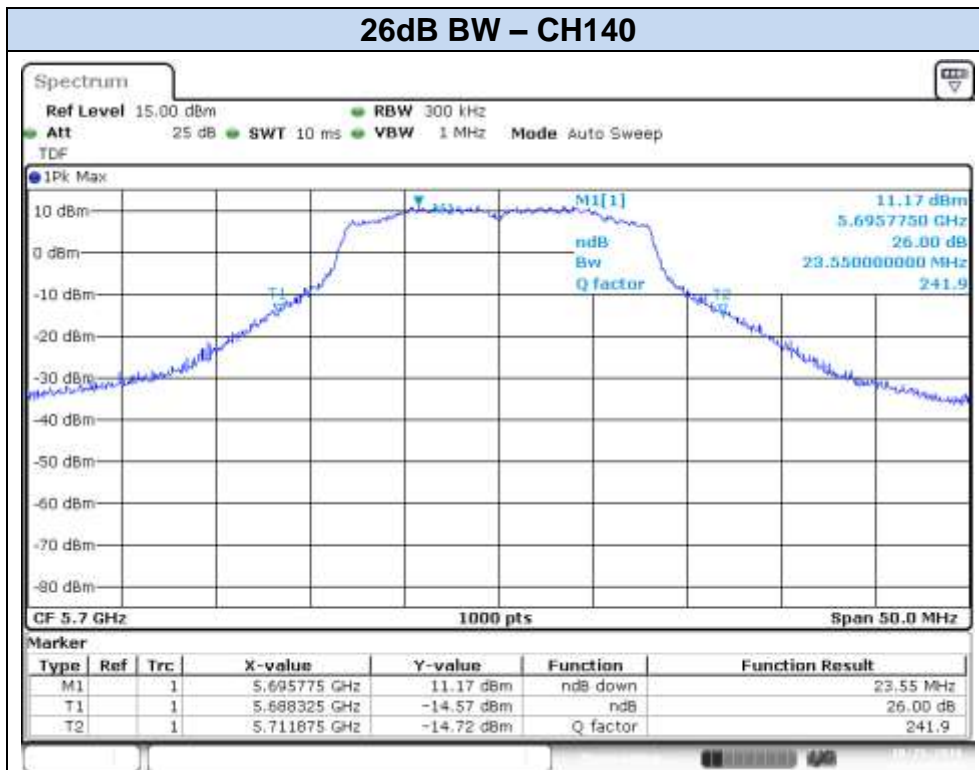



**802.11a, 6Mbps – Chain B**

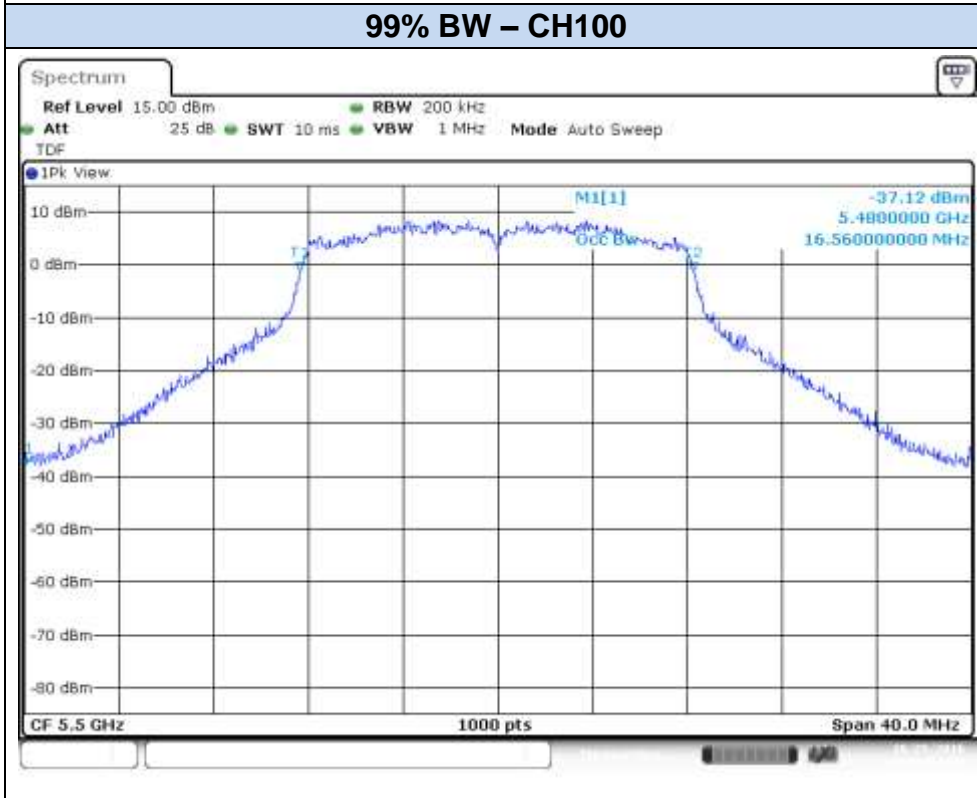
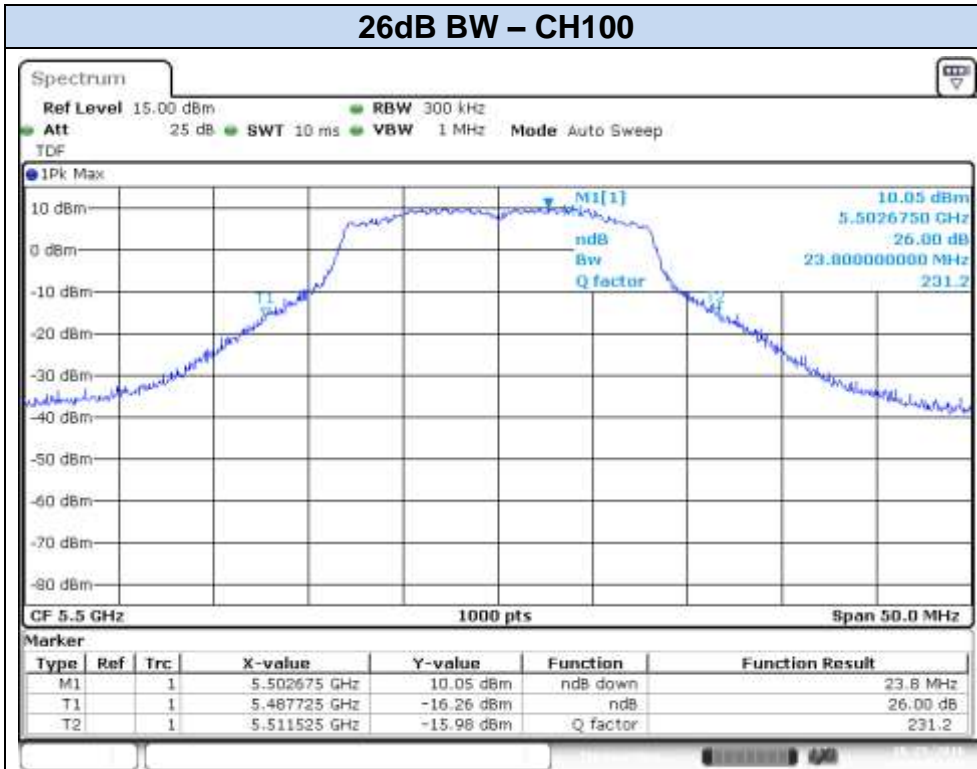

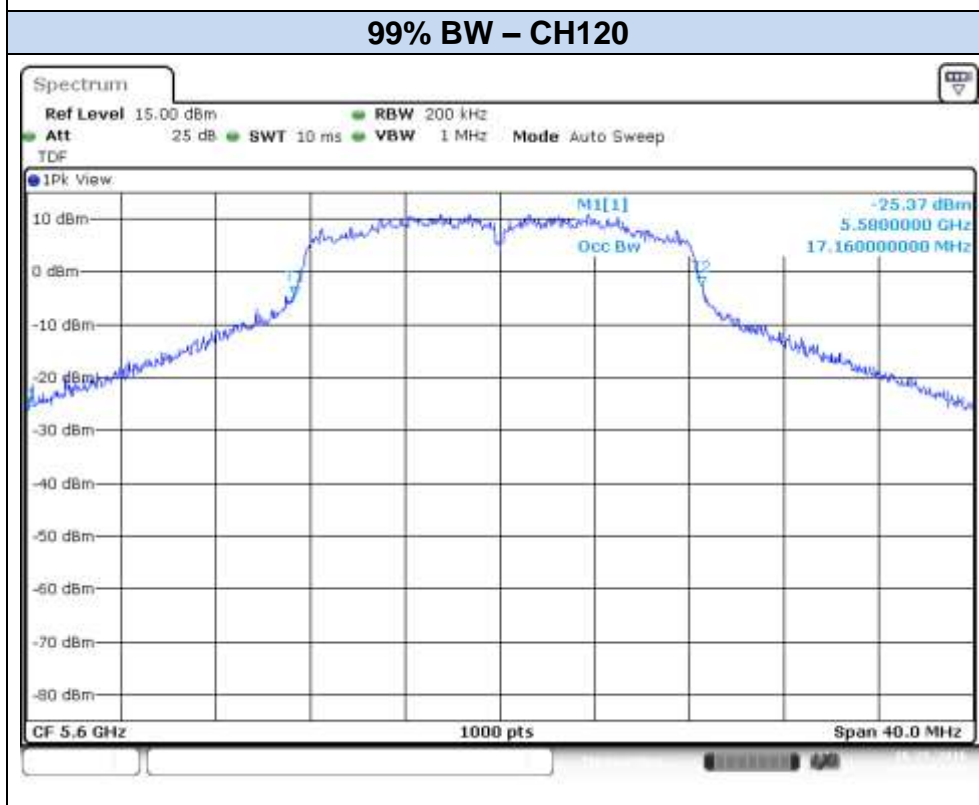
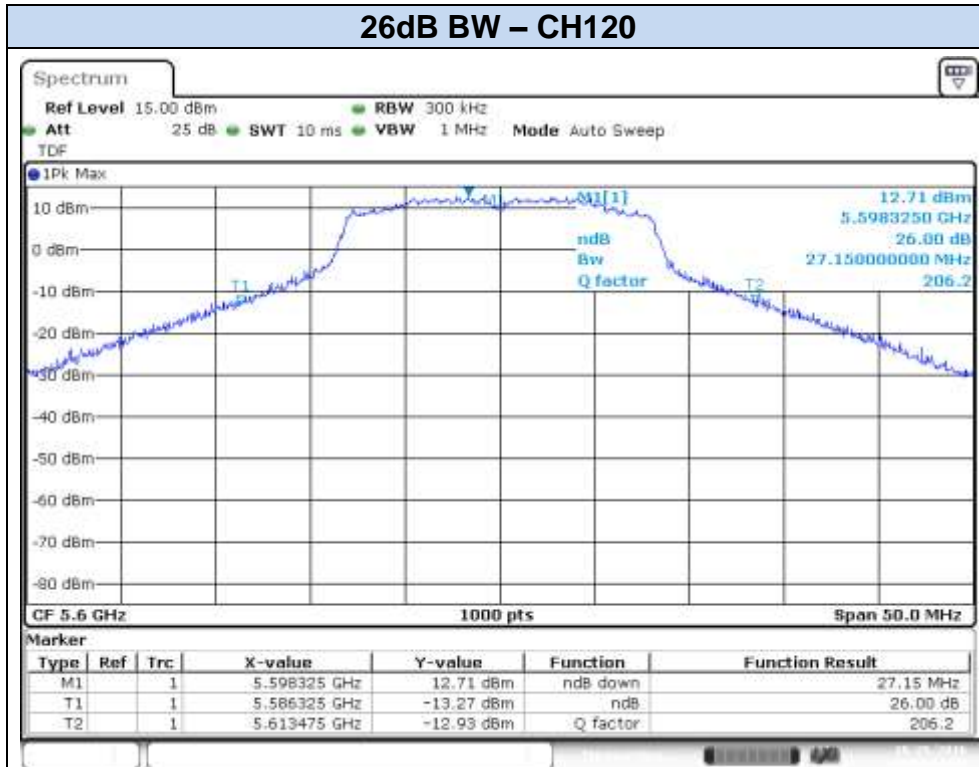

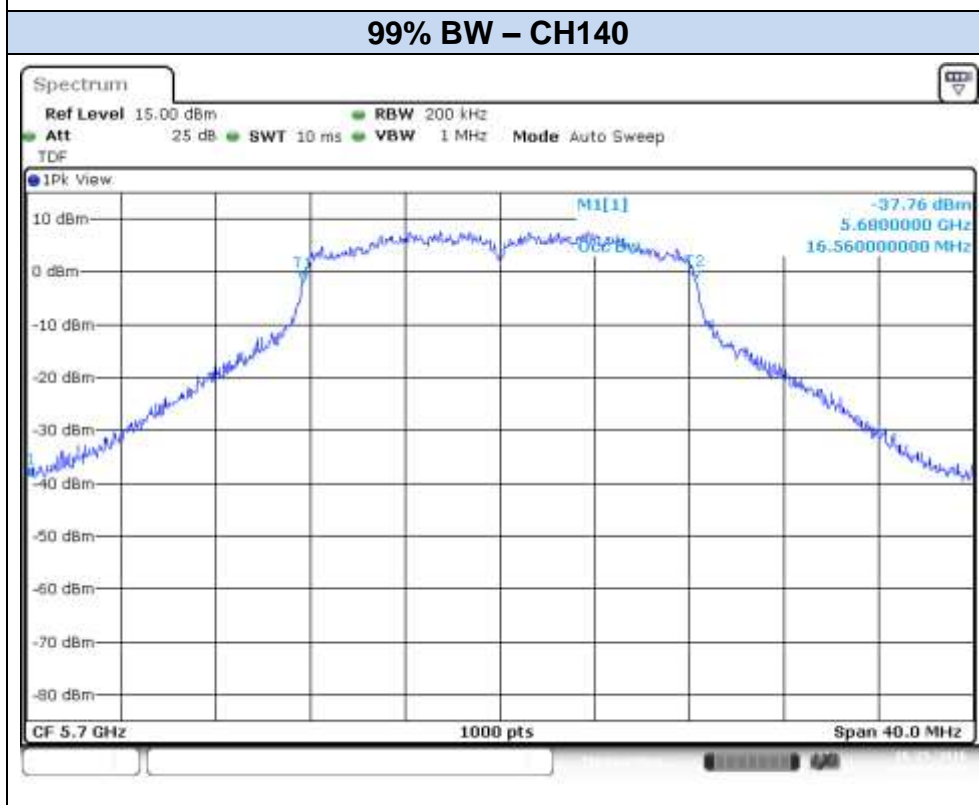
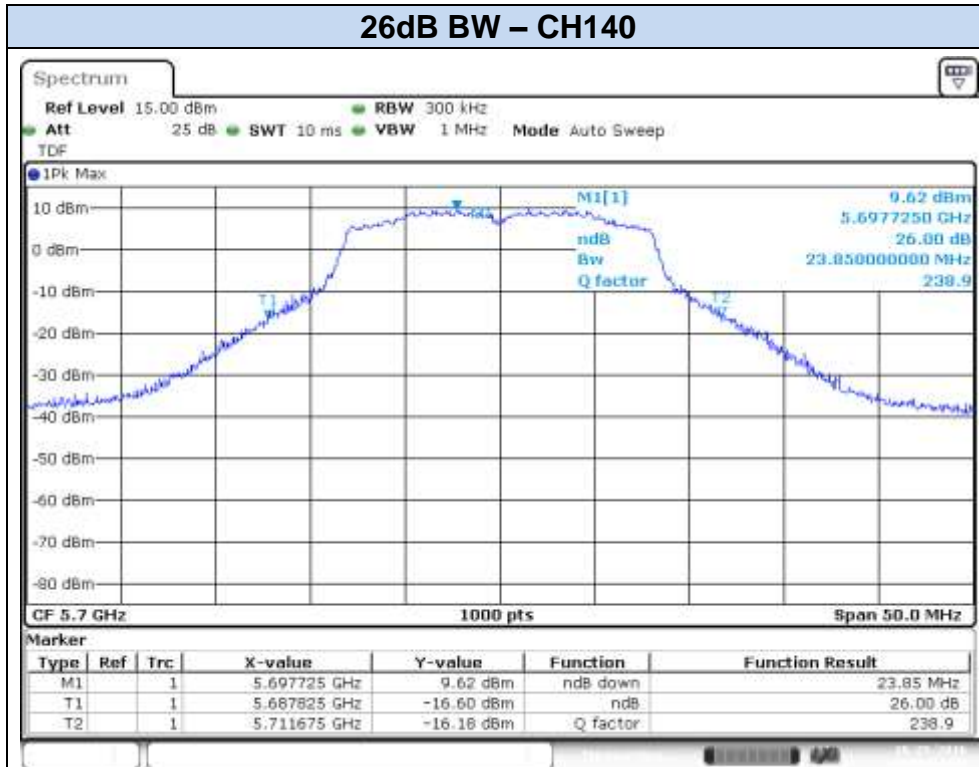

## 802.11n20, HT0 (SISO) – Chain A

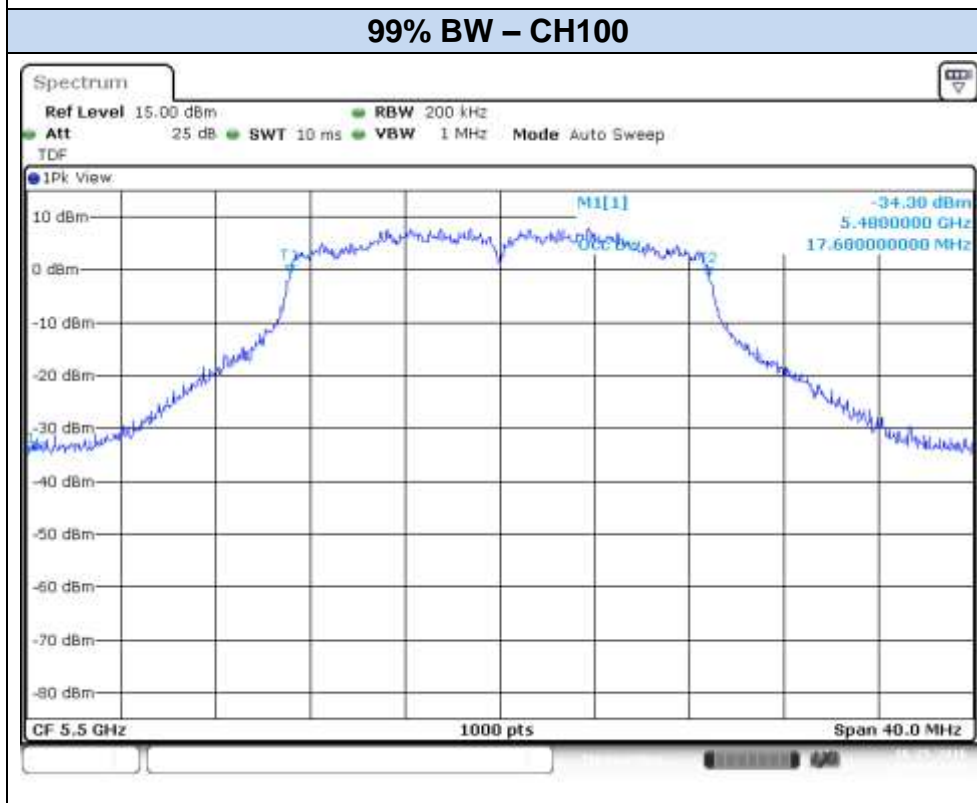
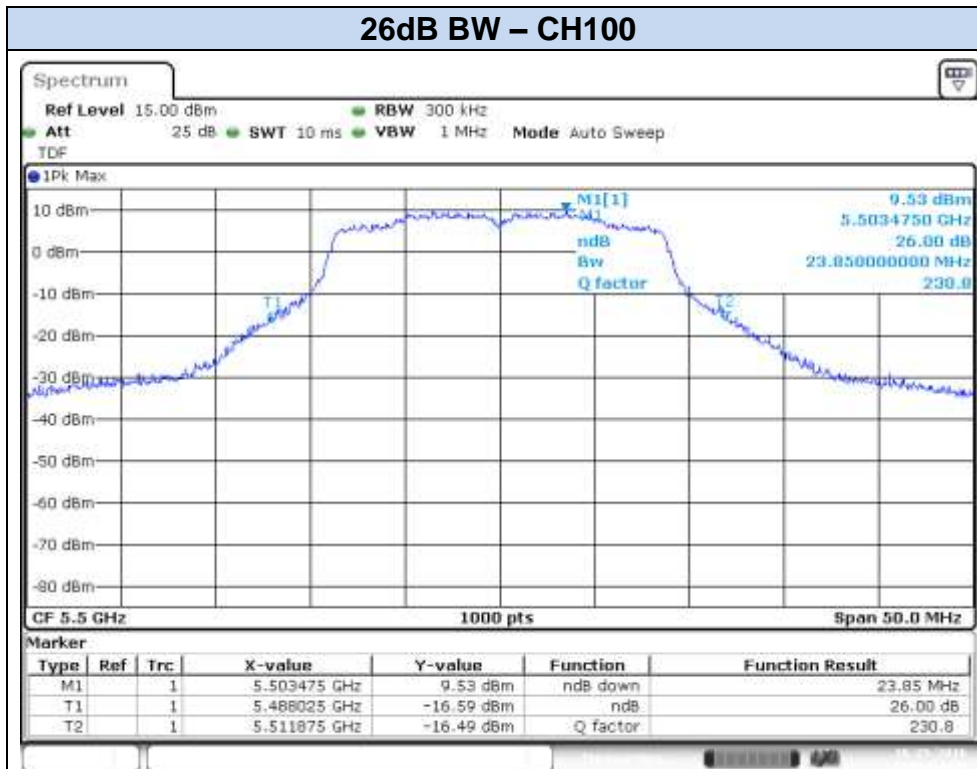

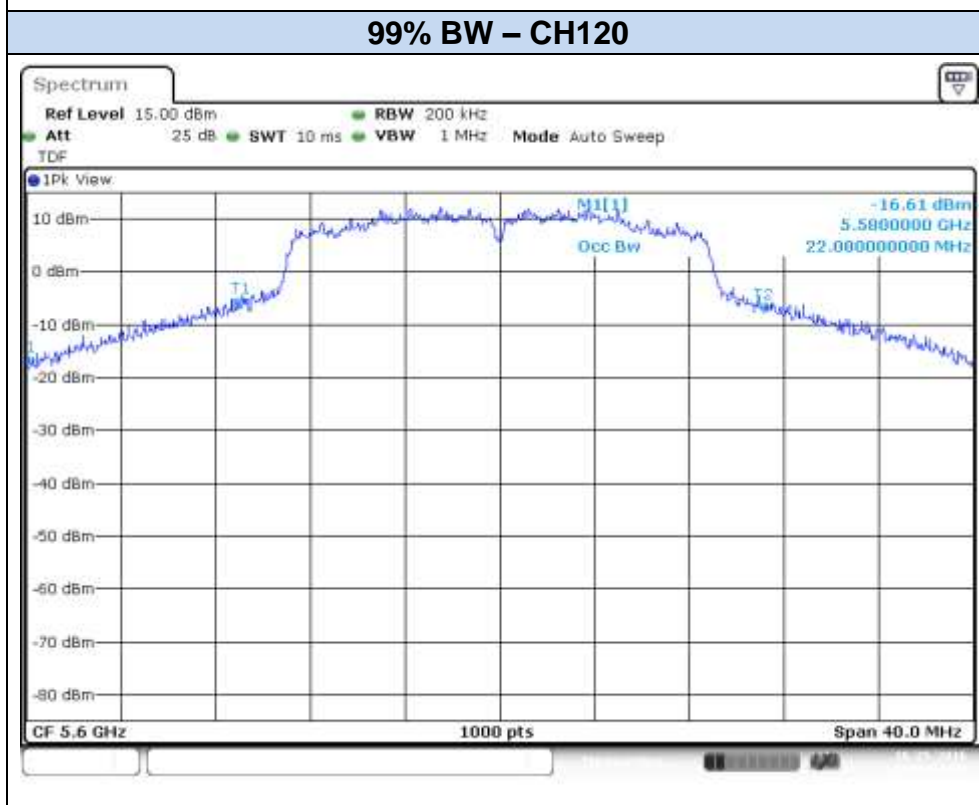
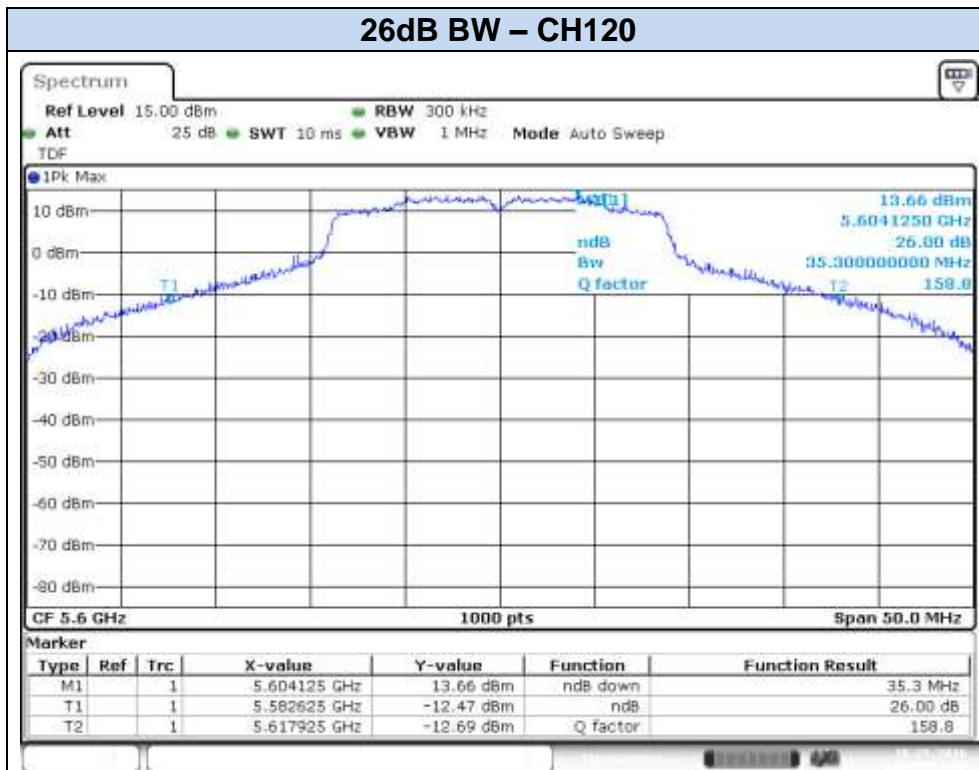

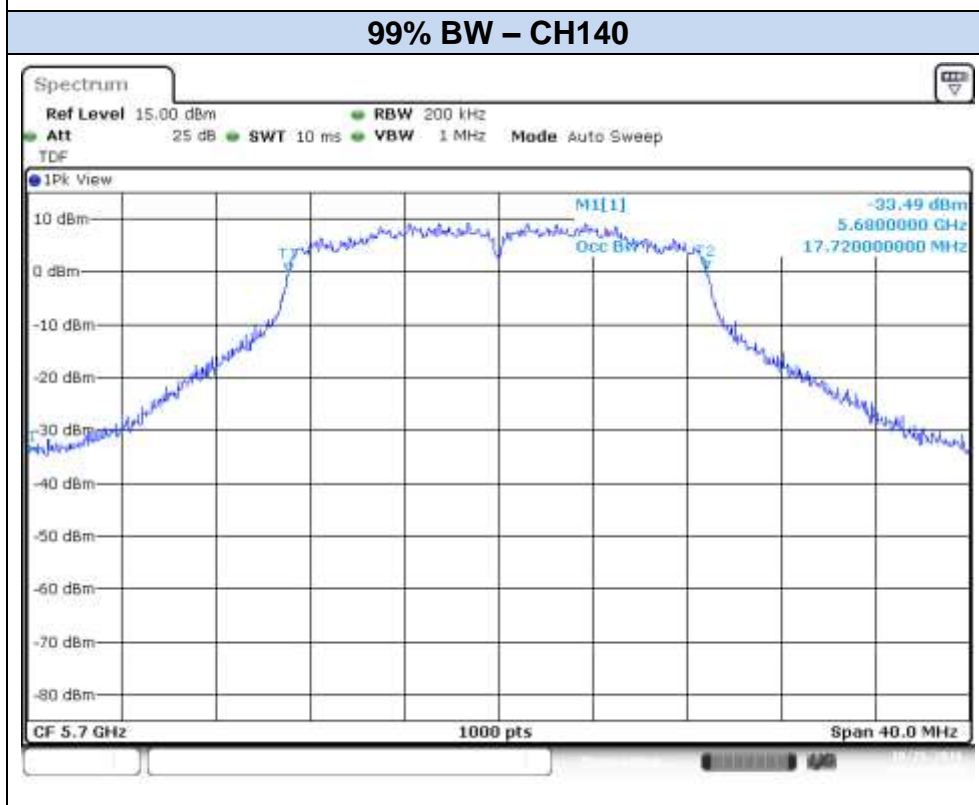
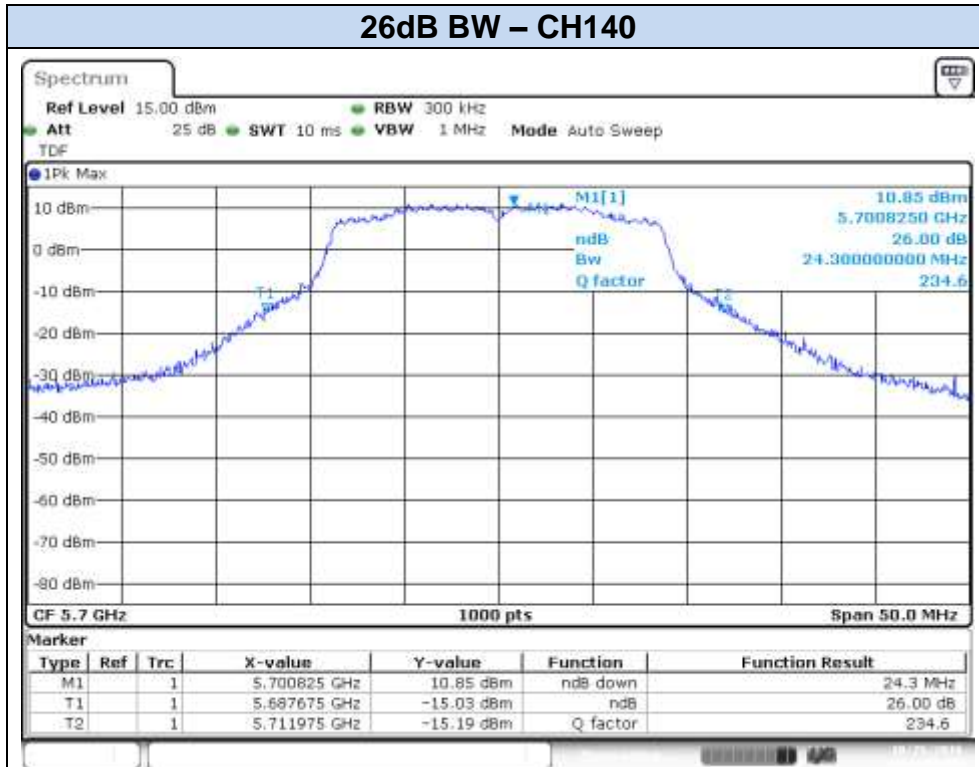

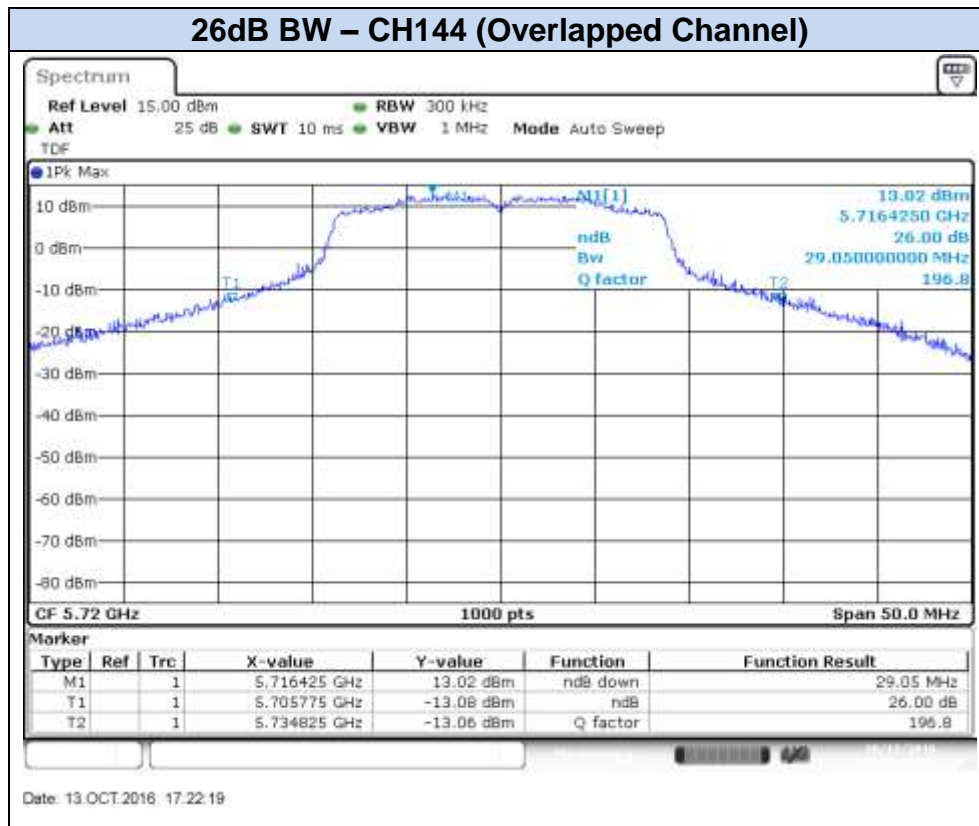



## 802.11n20, HT0 (SISO) – Chain B

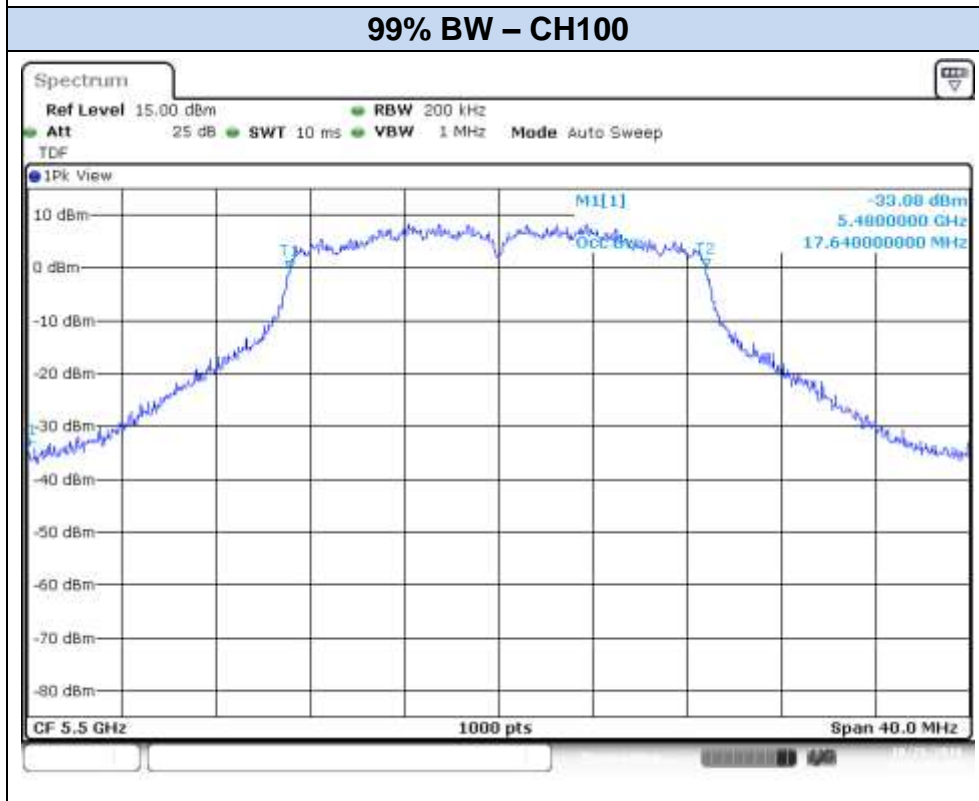
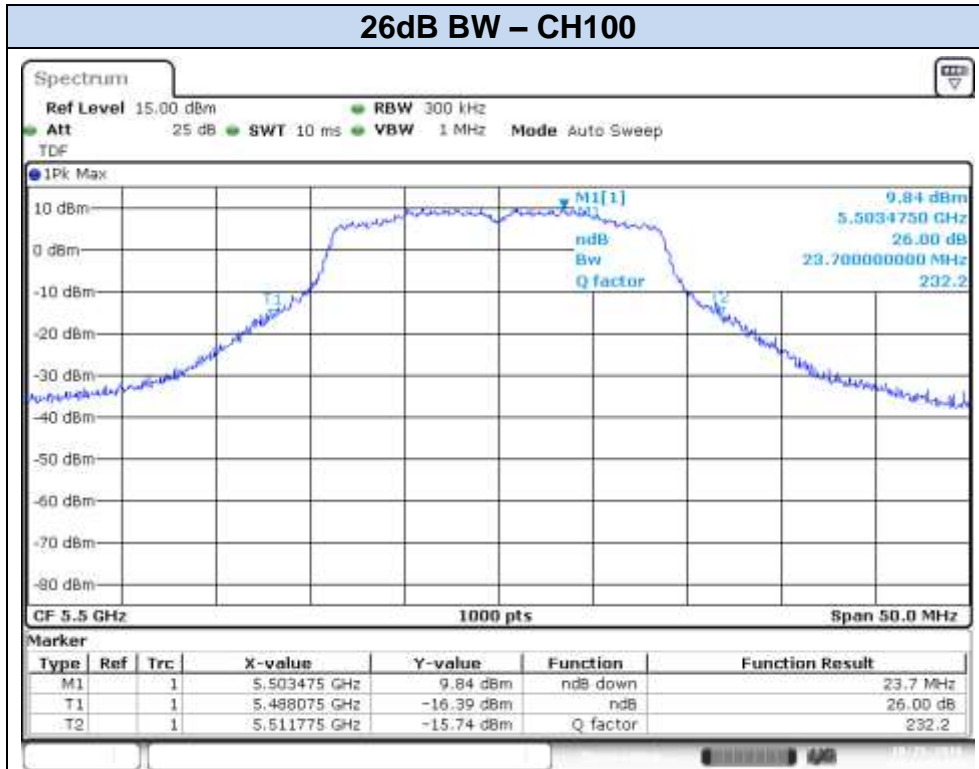



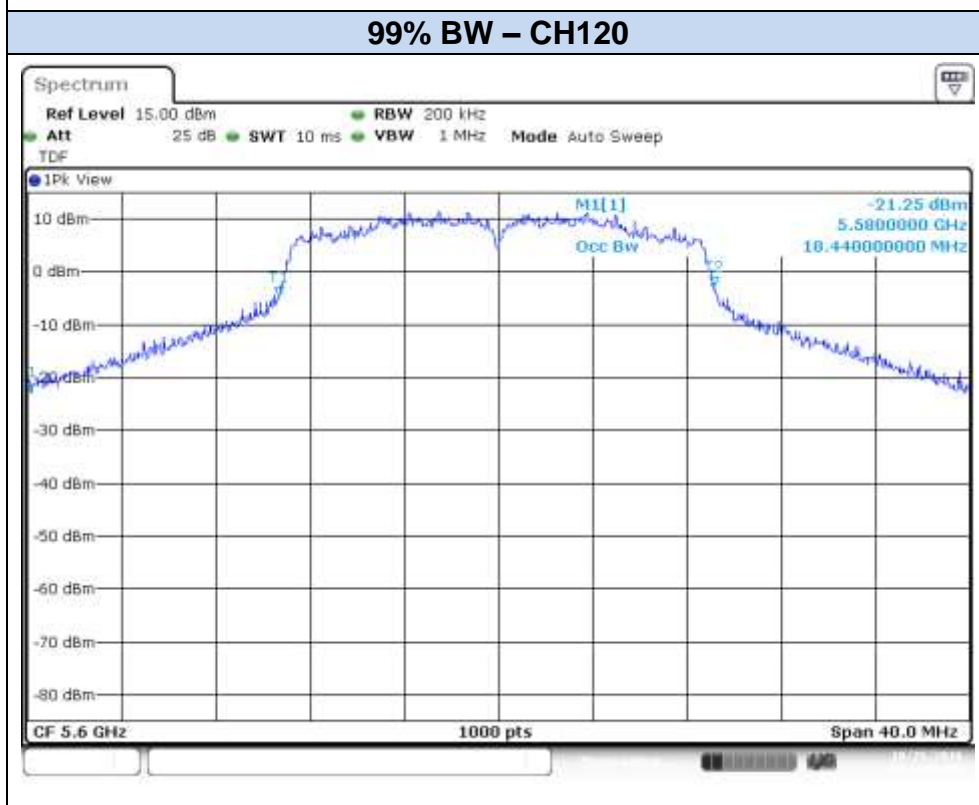
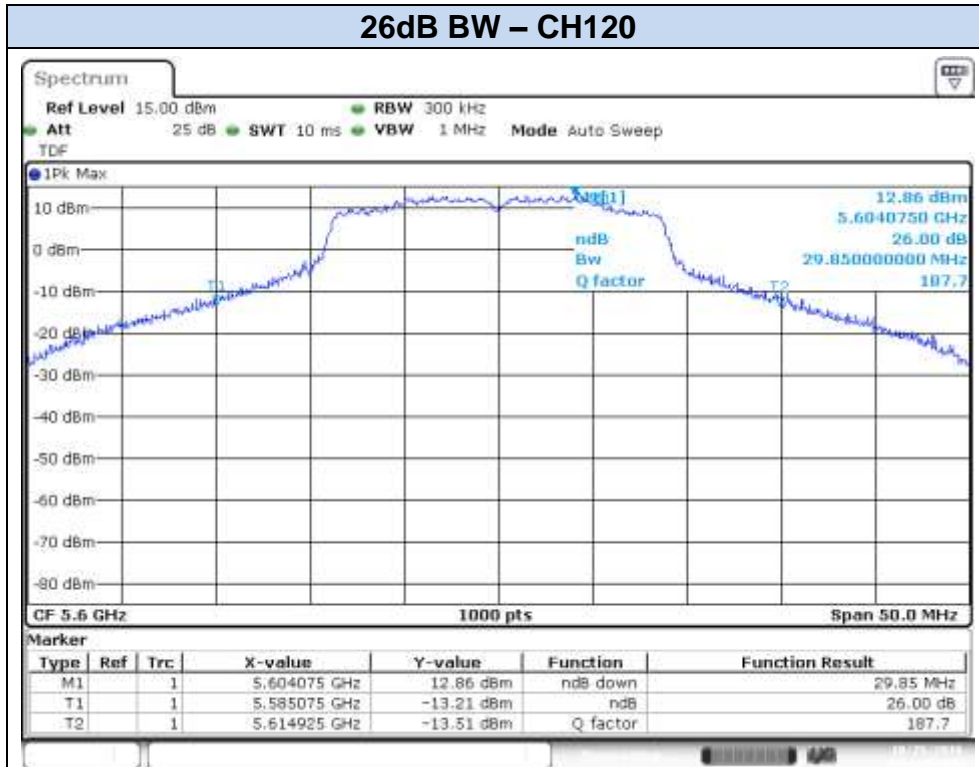

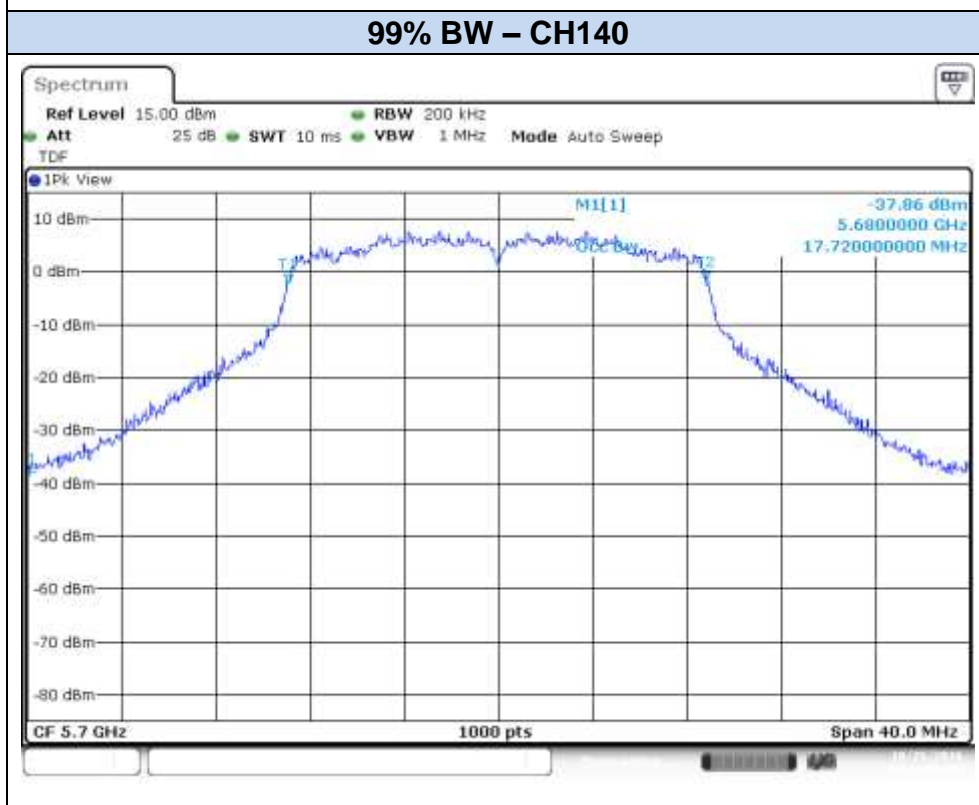
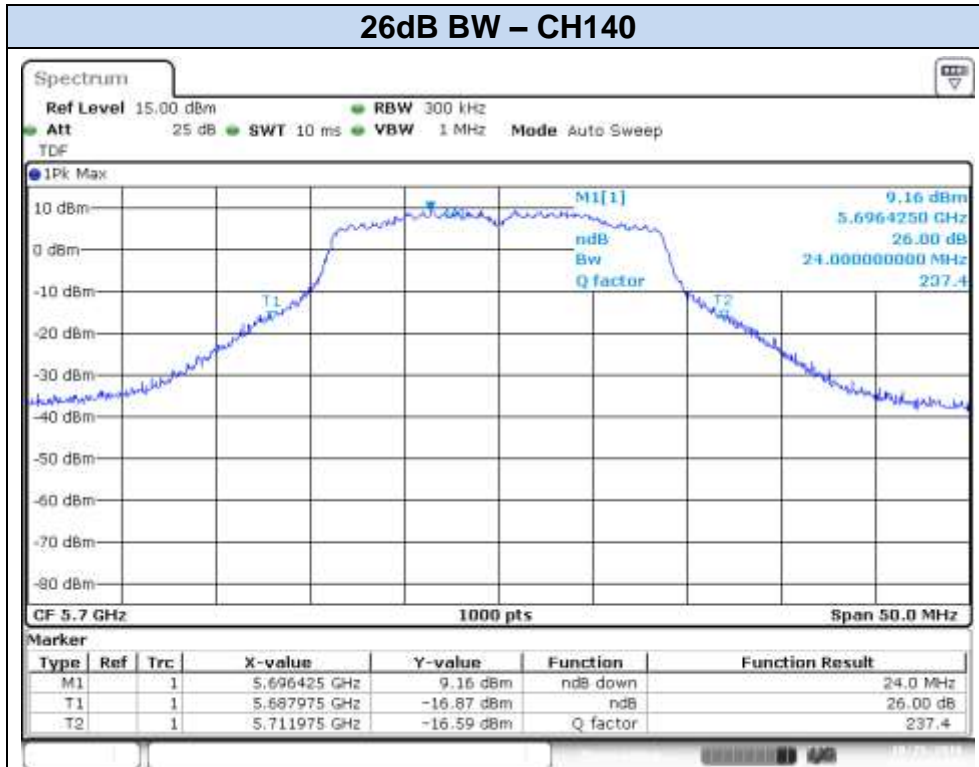

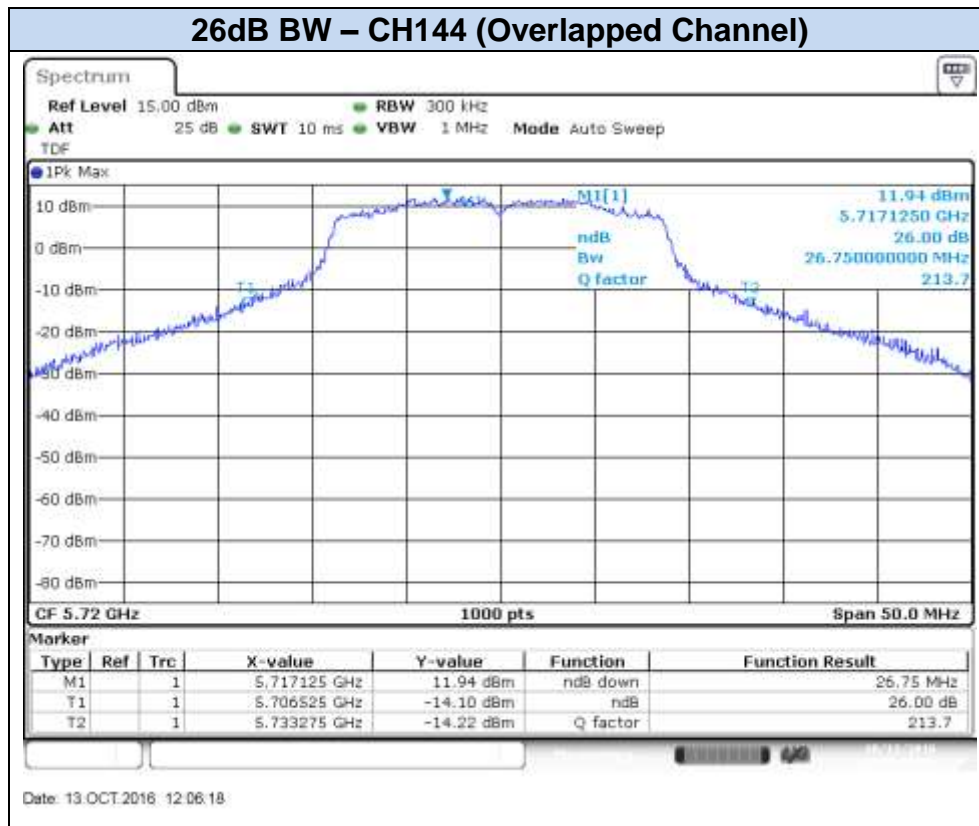

## 802.11n20, HT8 (MIMO) – Chain A

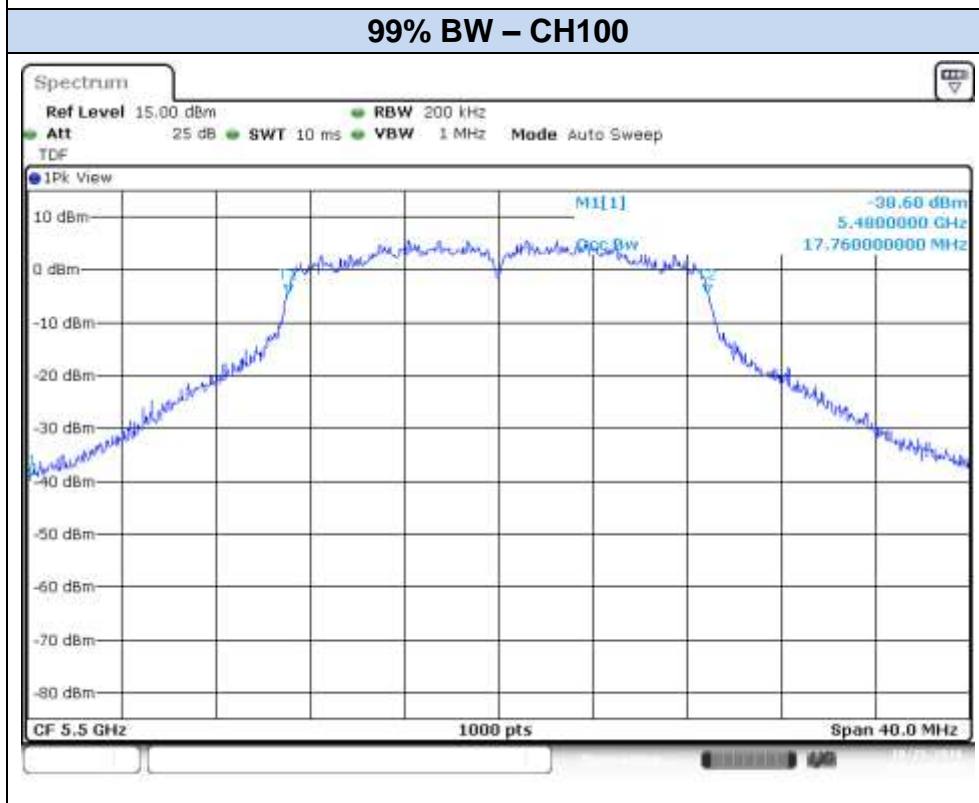
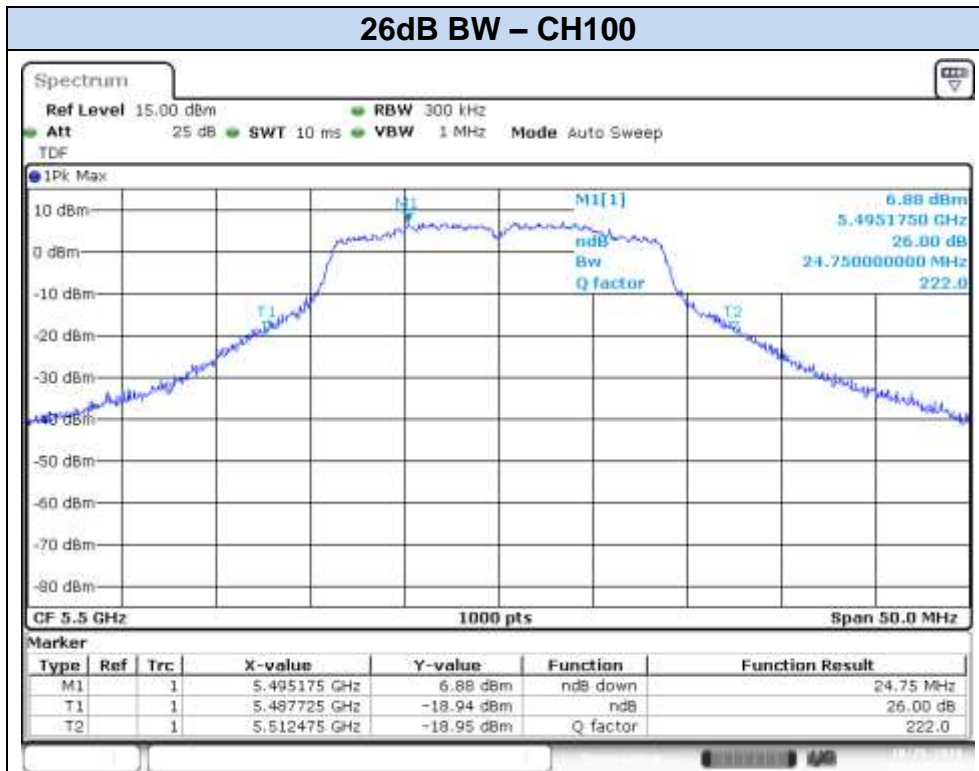

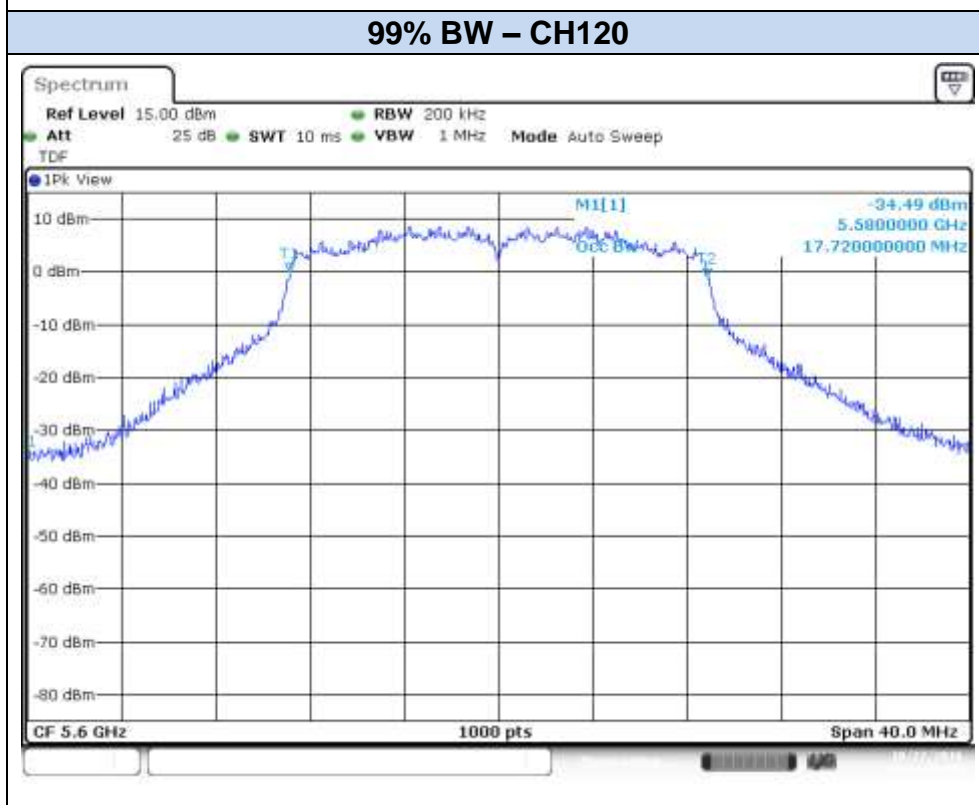
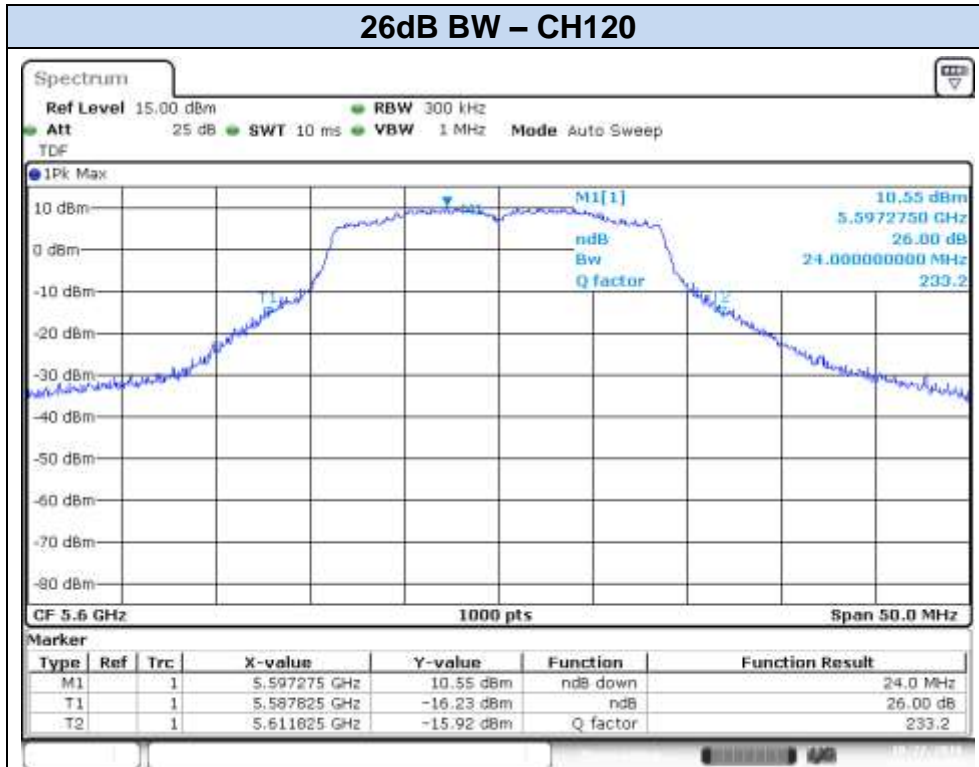

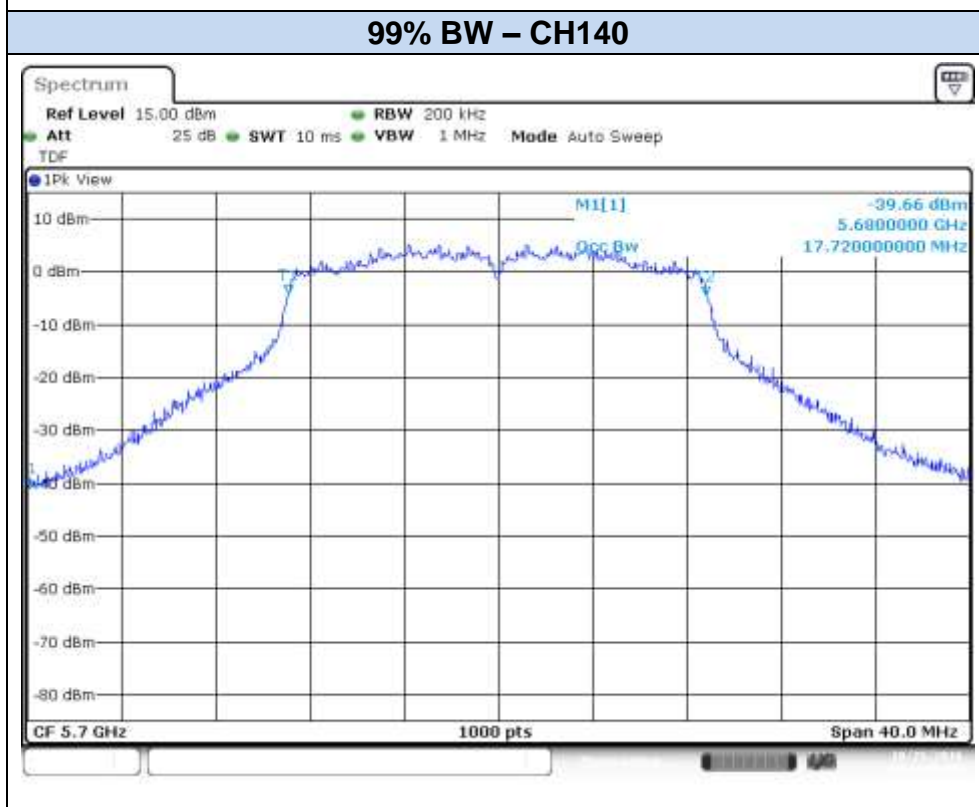
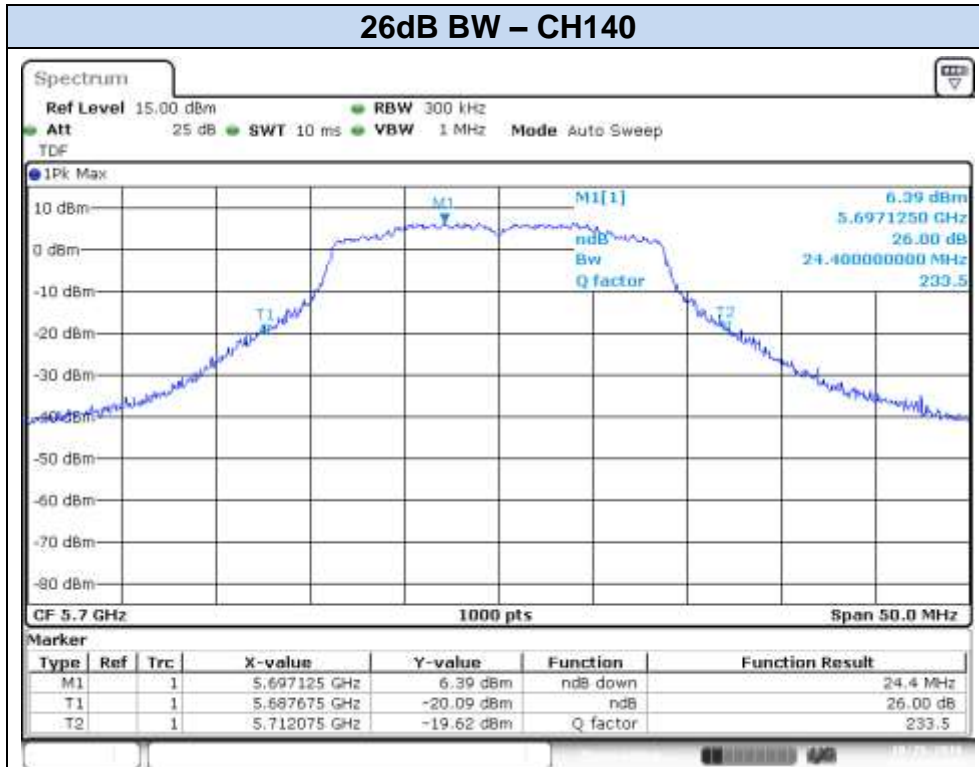

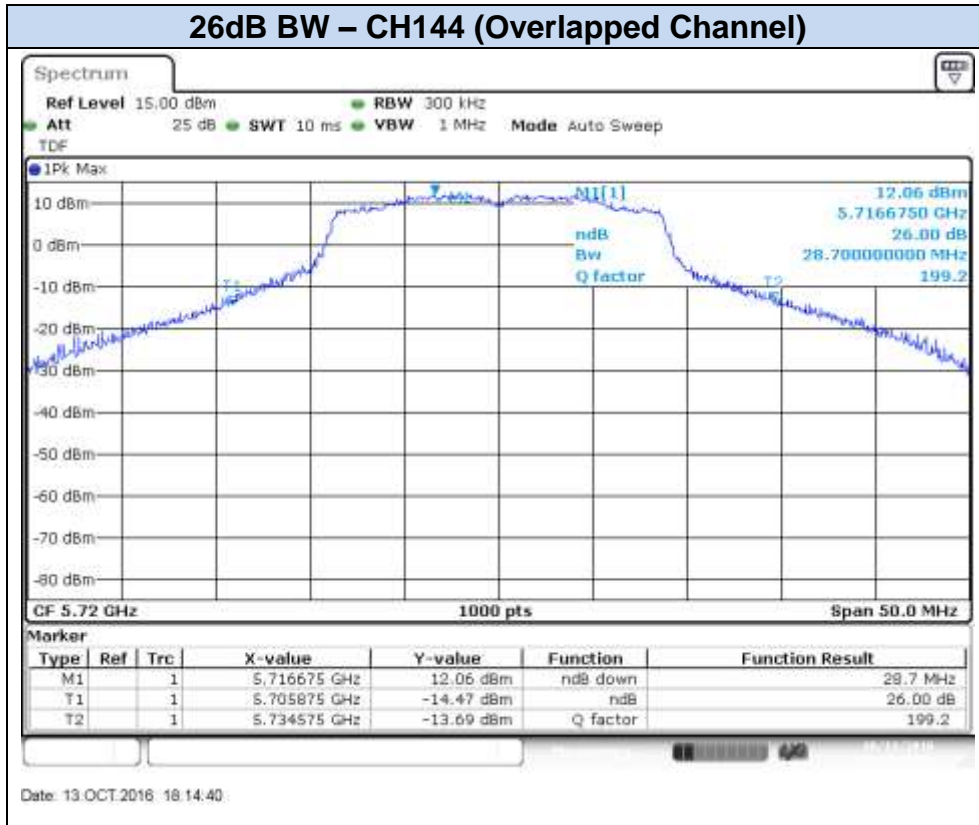



**802.11n20, HT8 (MIMO) – Chain B**

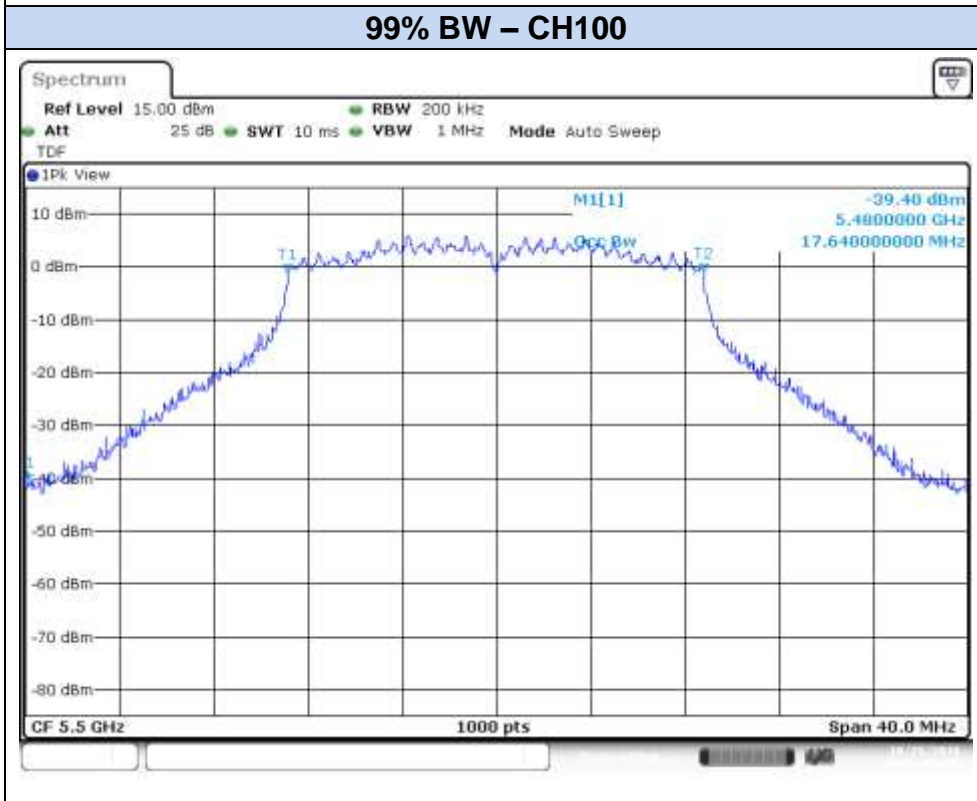
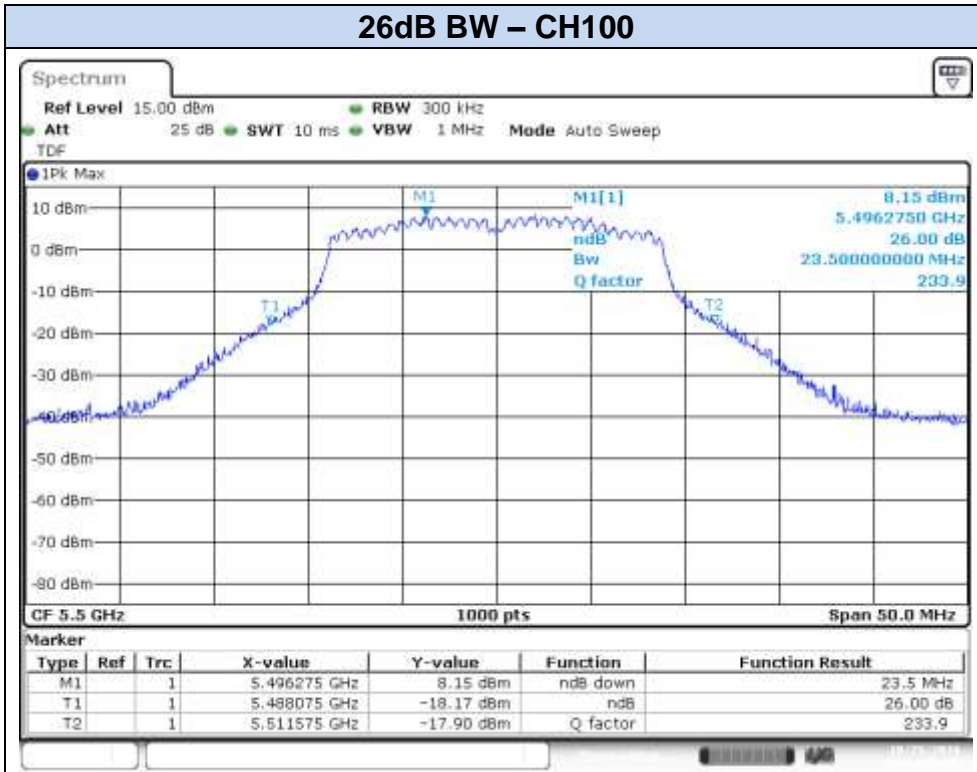



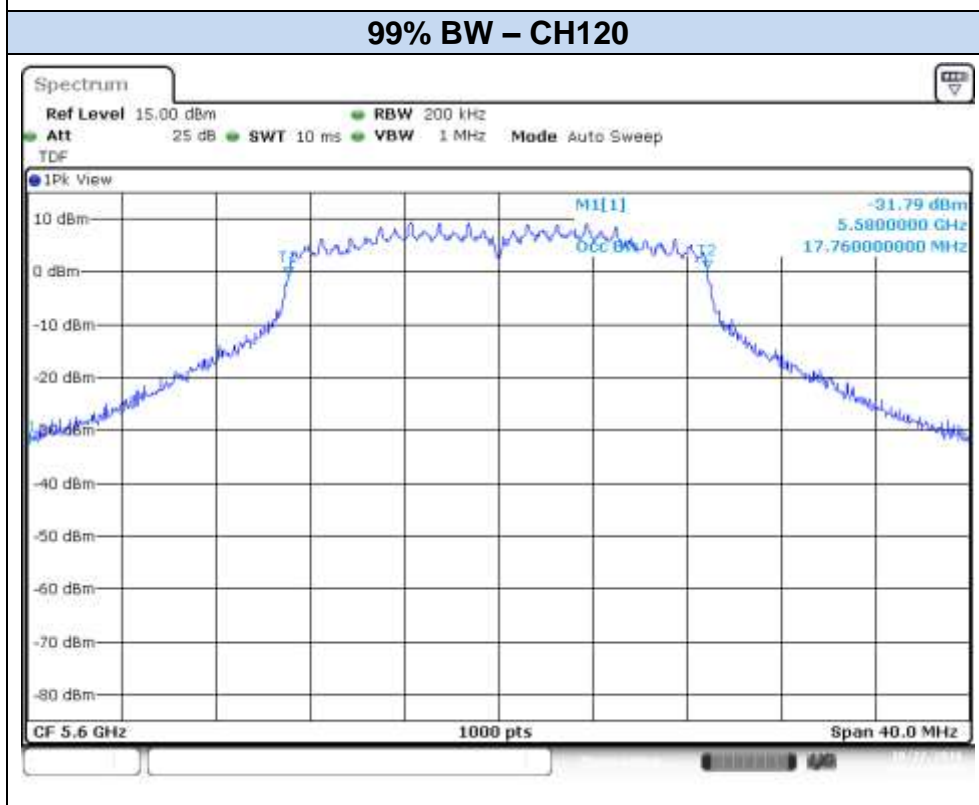
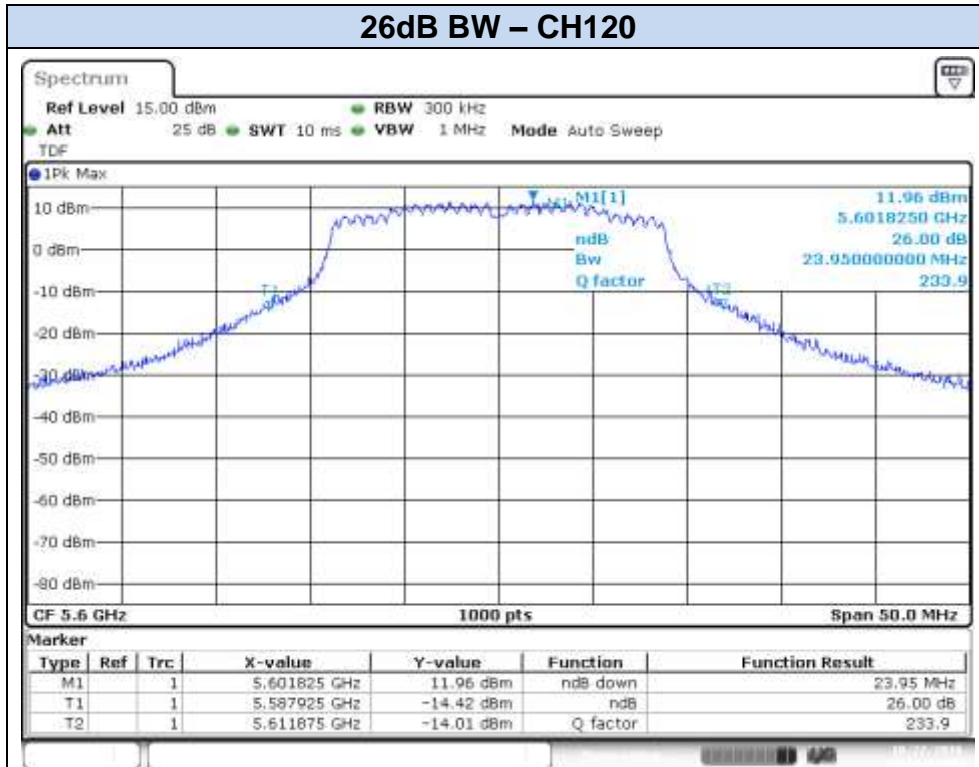

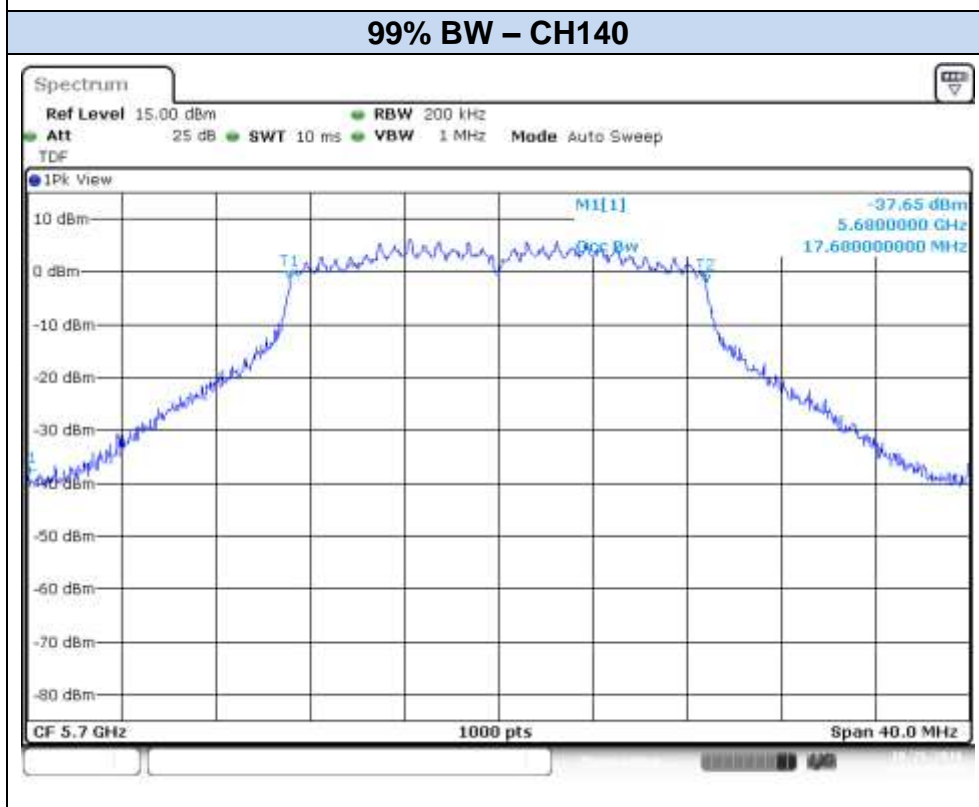
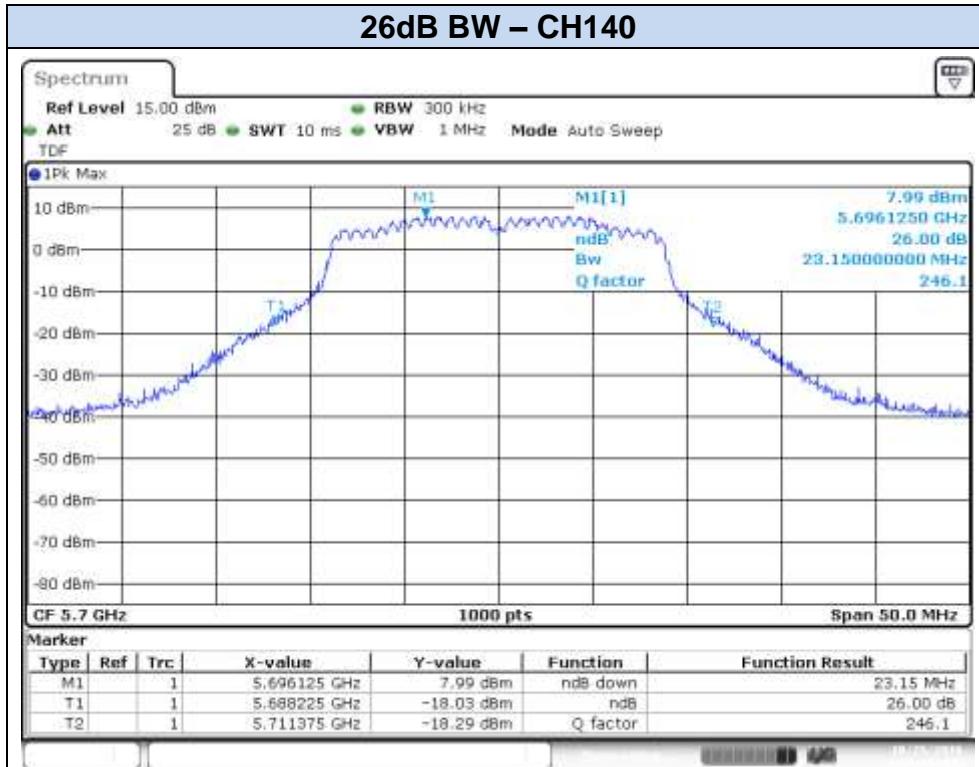

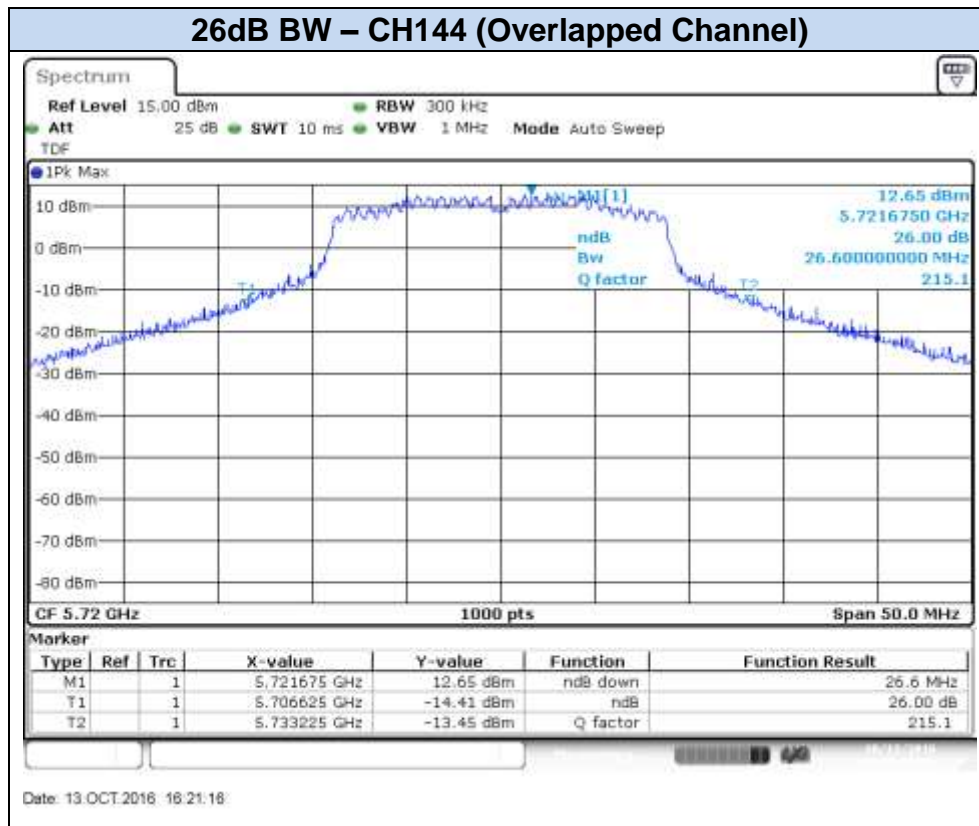

## 802.11n40, HT0 (SISO) – Chain A

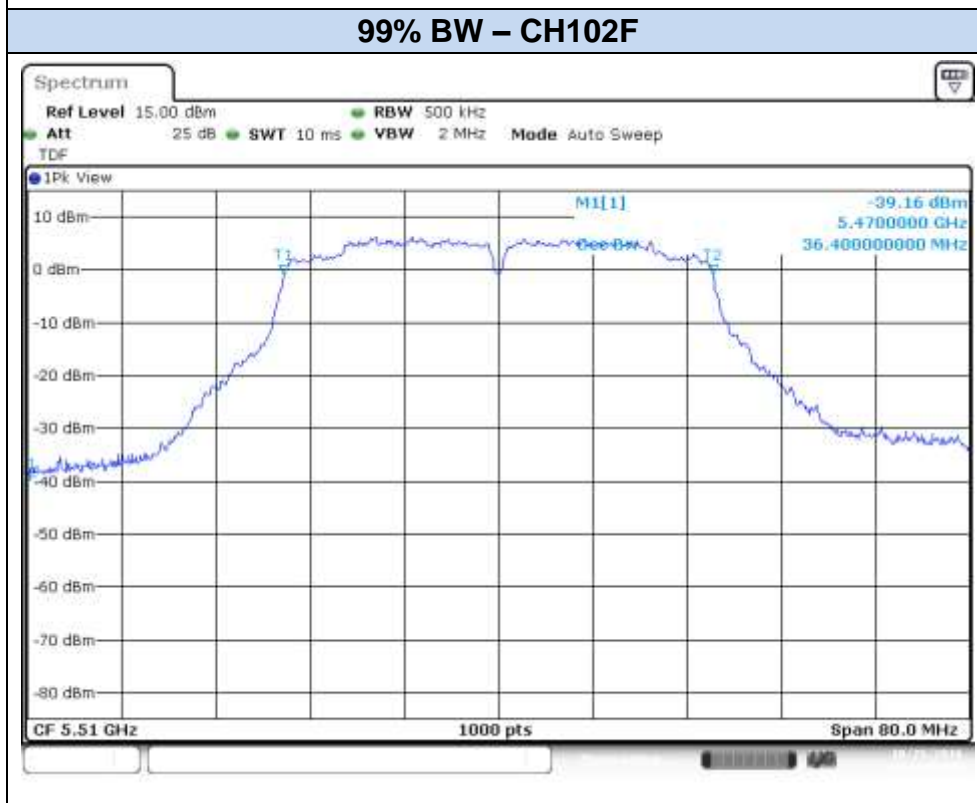
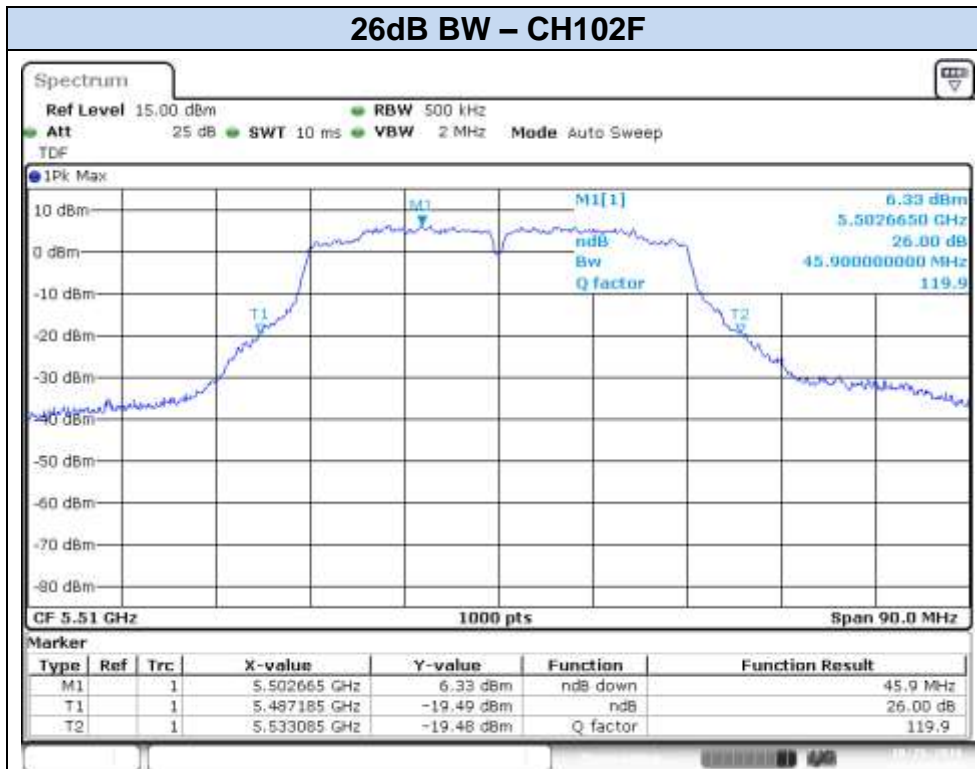

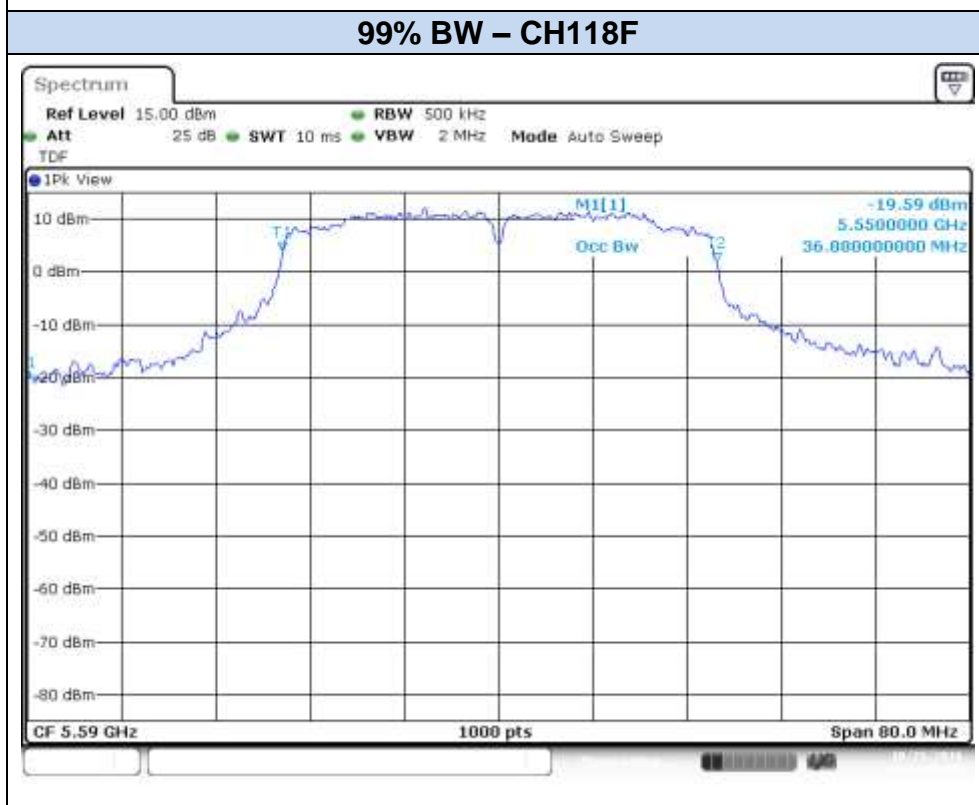
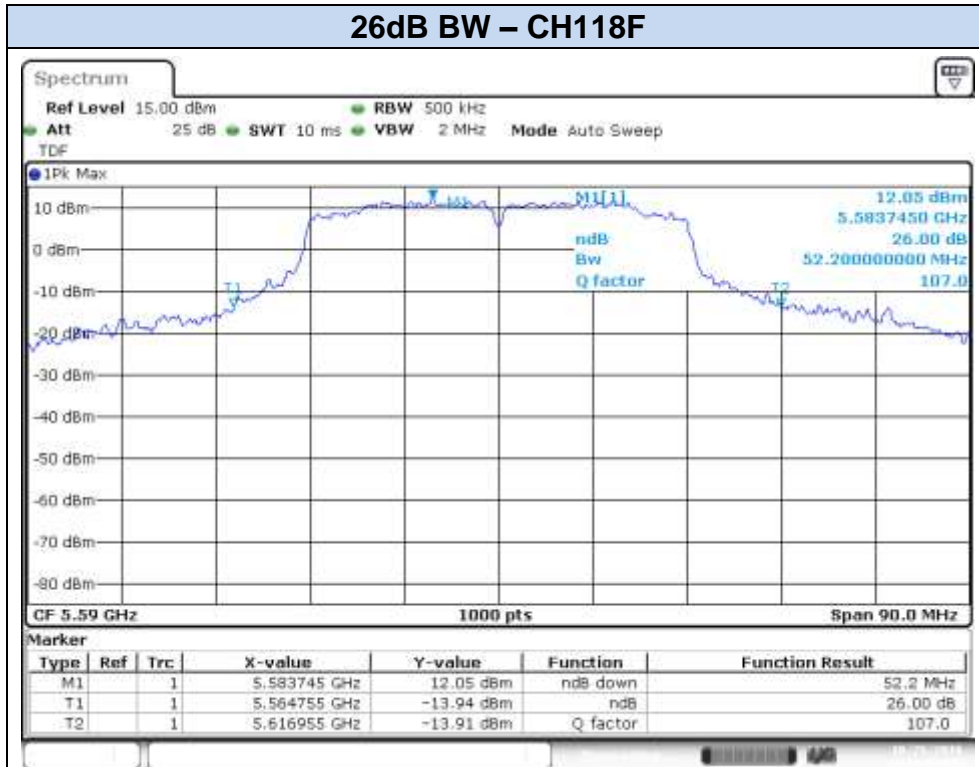

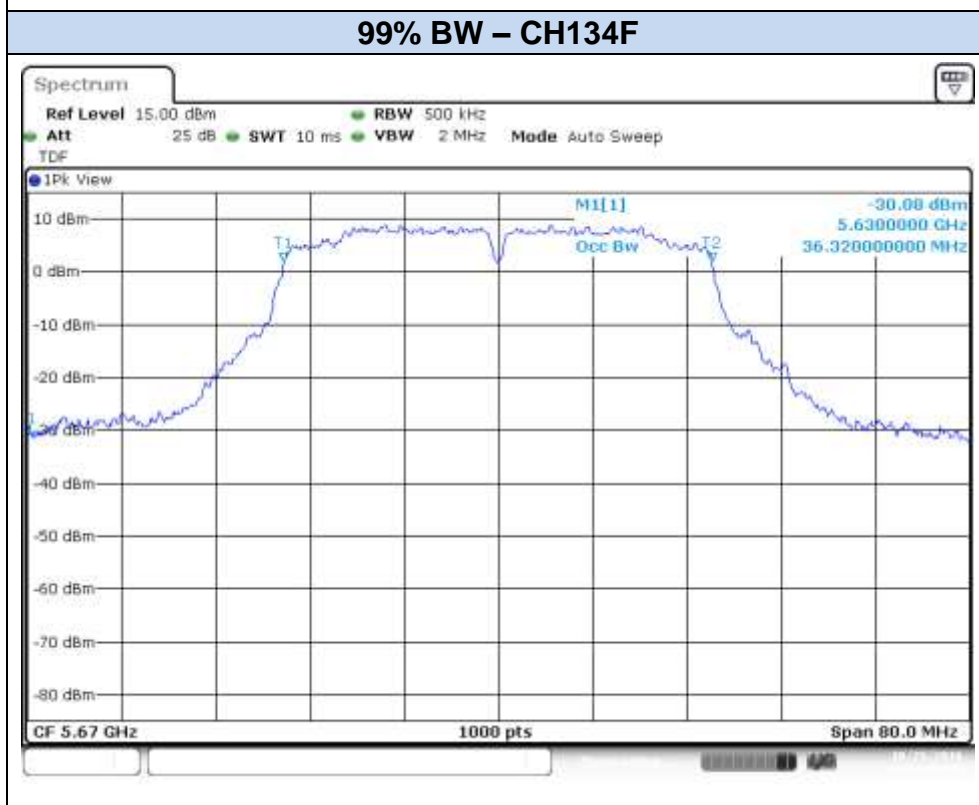
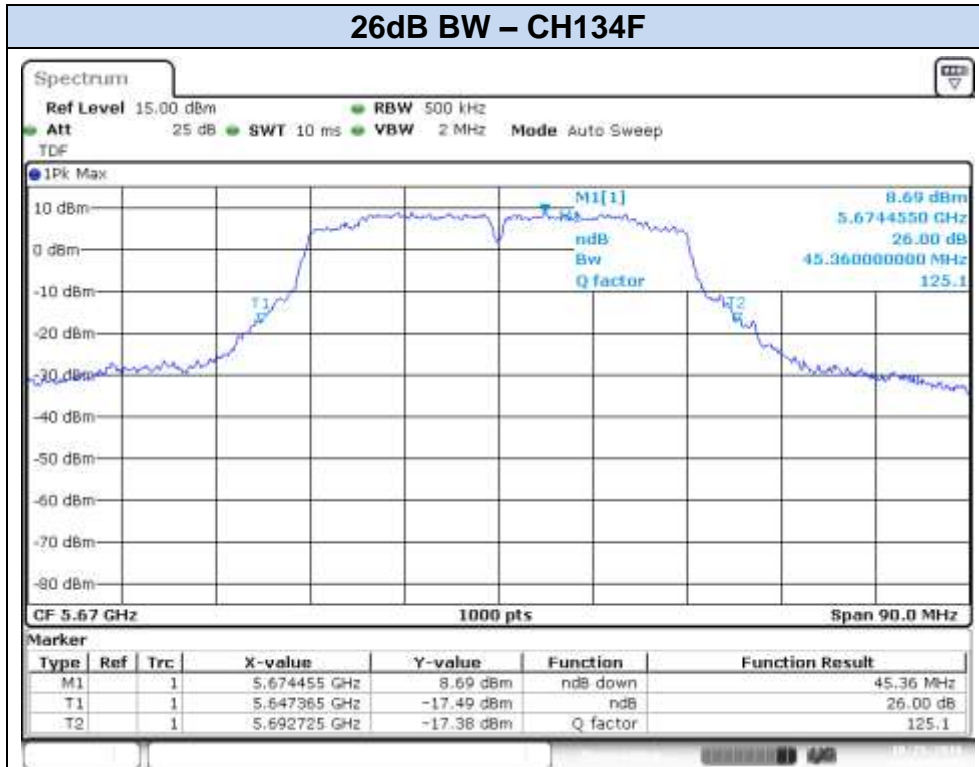

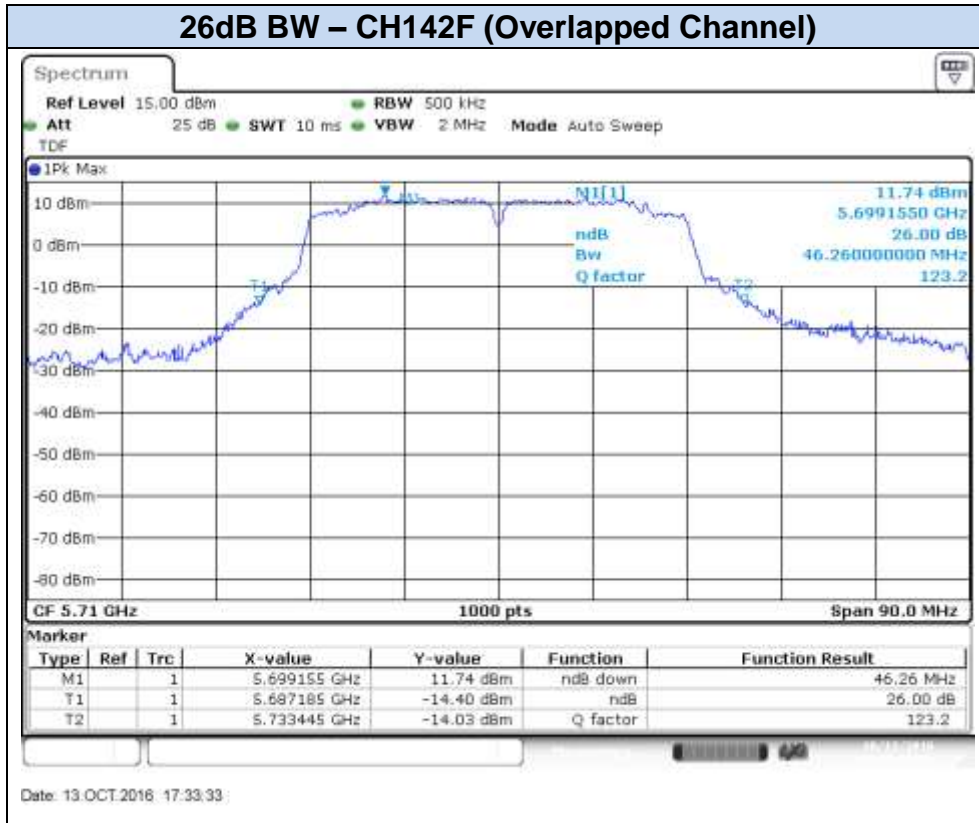



**802.11n40, HT0 (SISO) – Chain B**

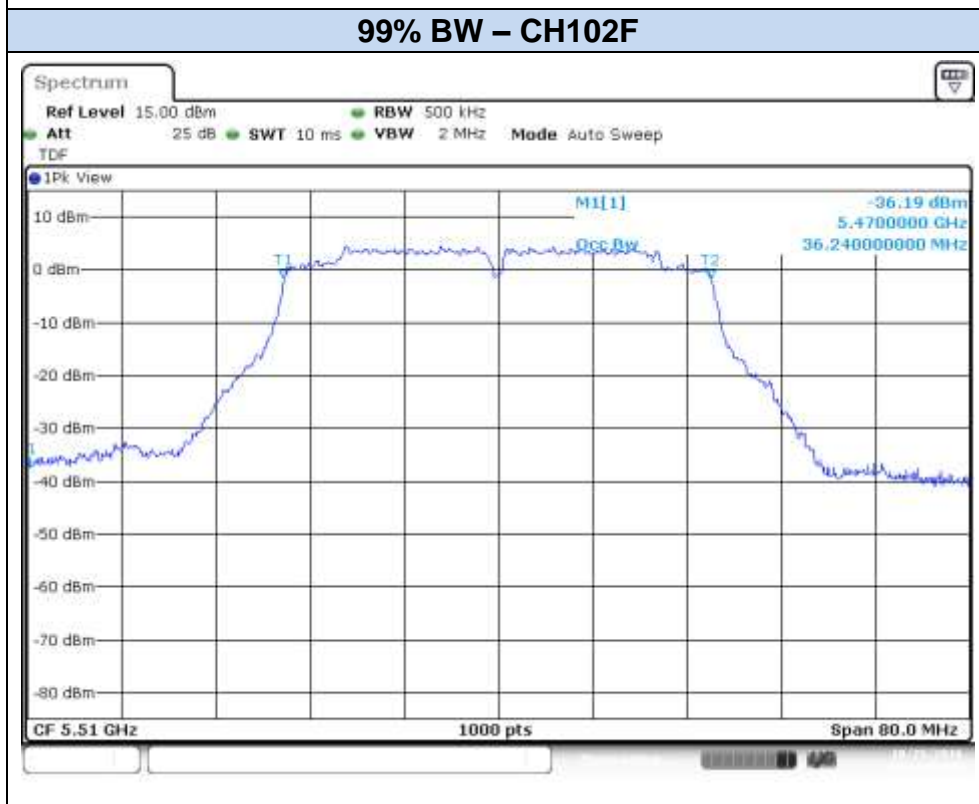
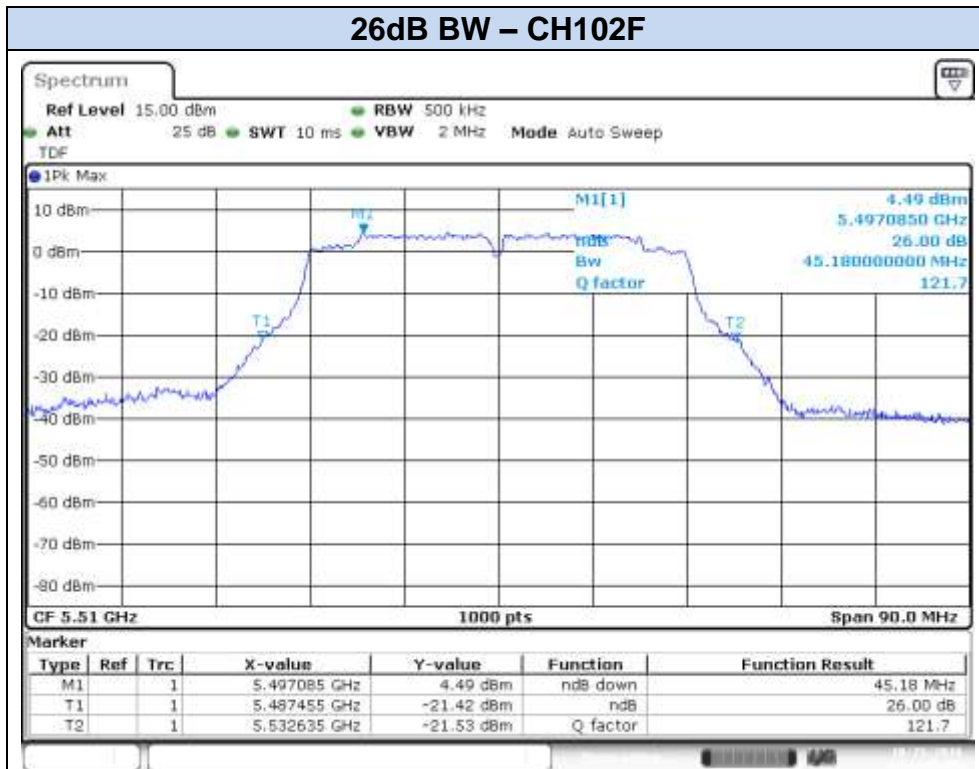



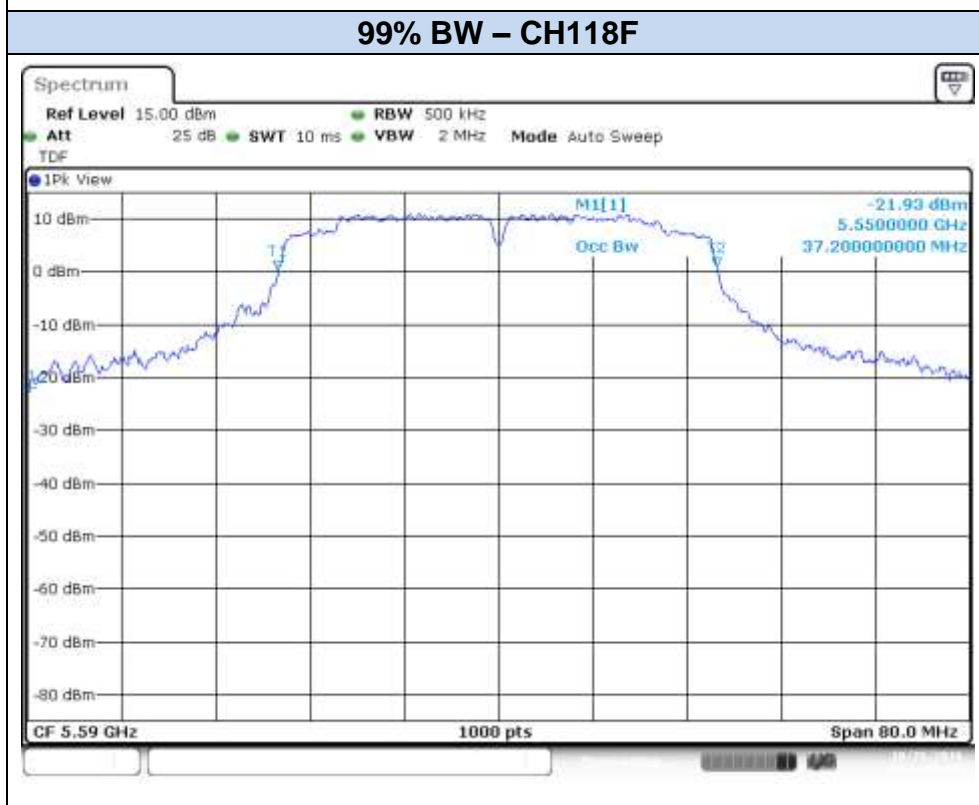
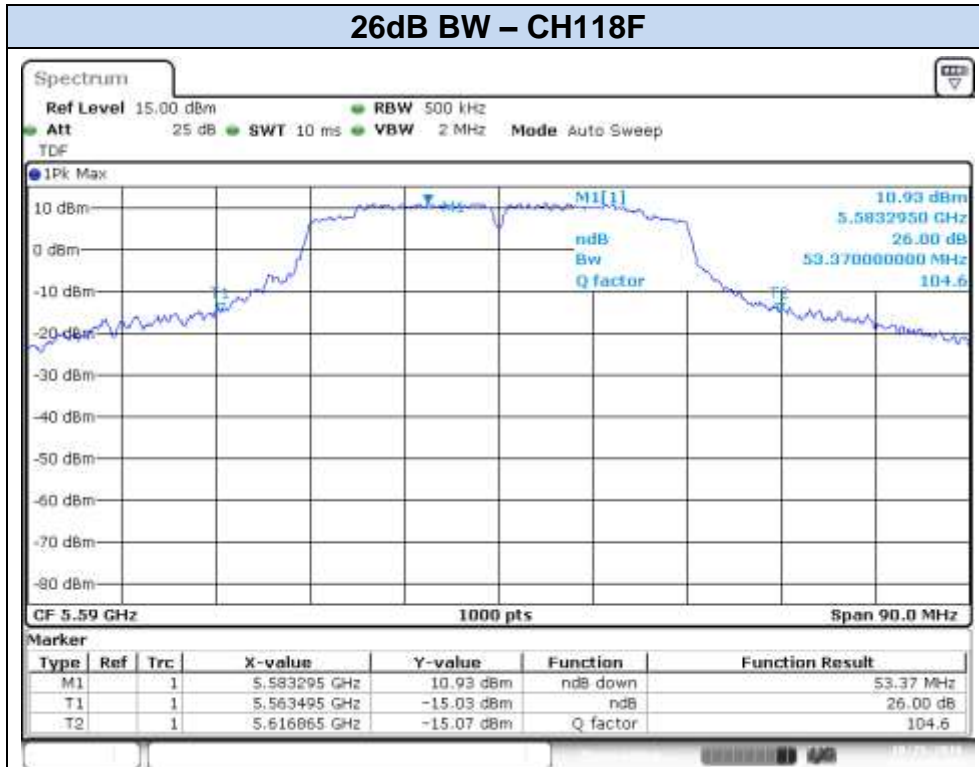

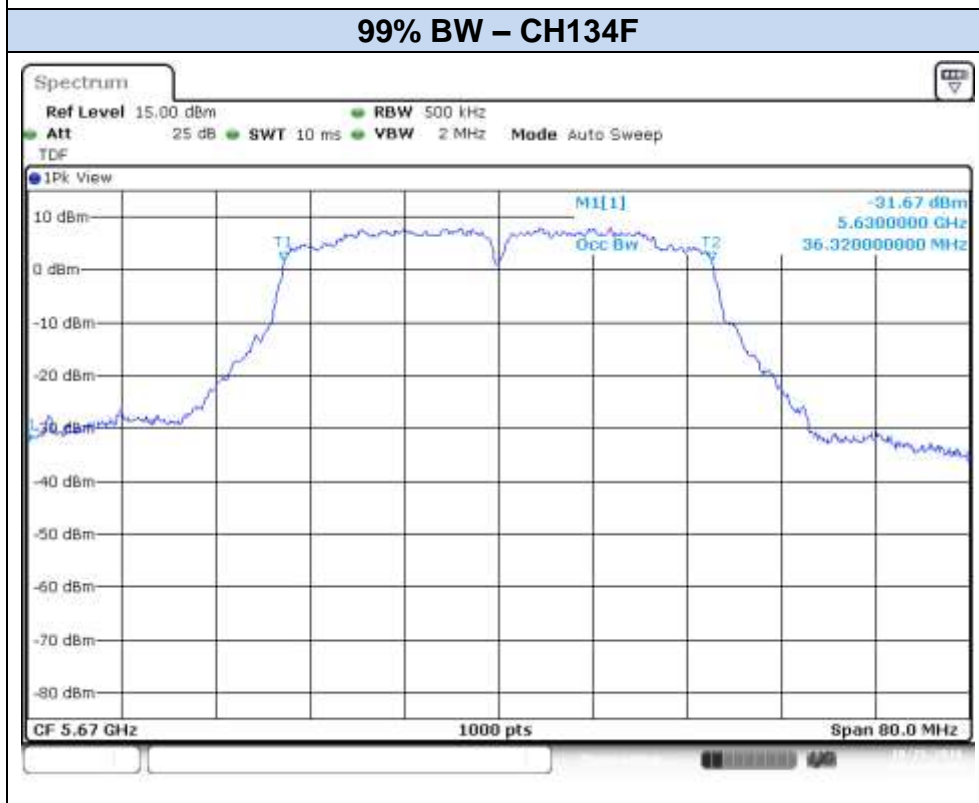
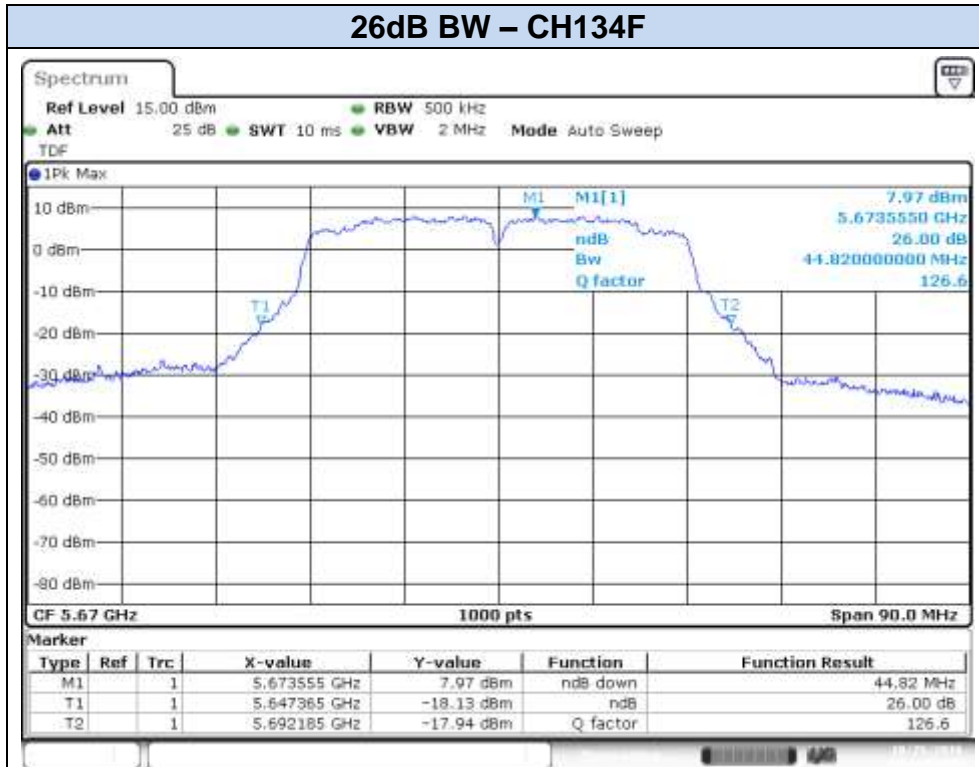

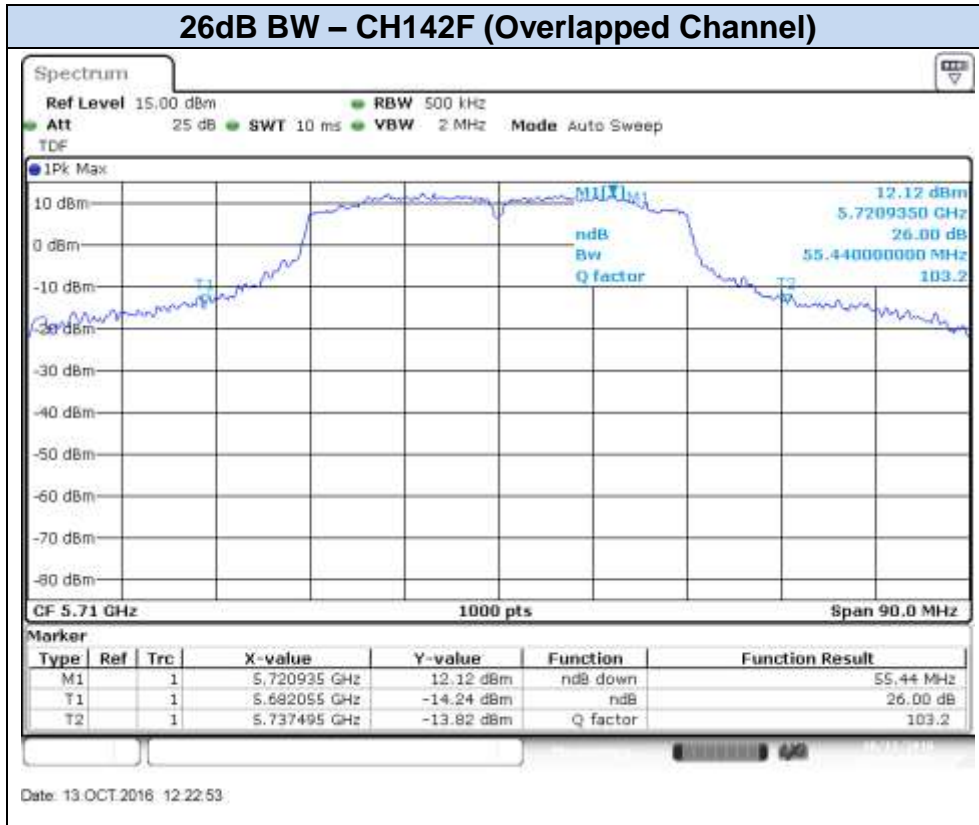

**802.11n40, HT8 (MIMO) – Chain A**

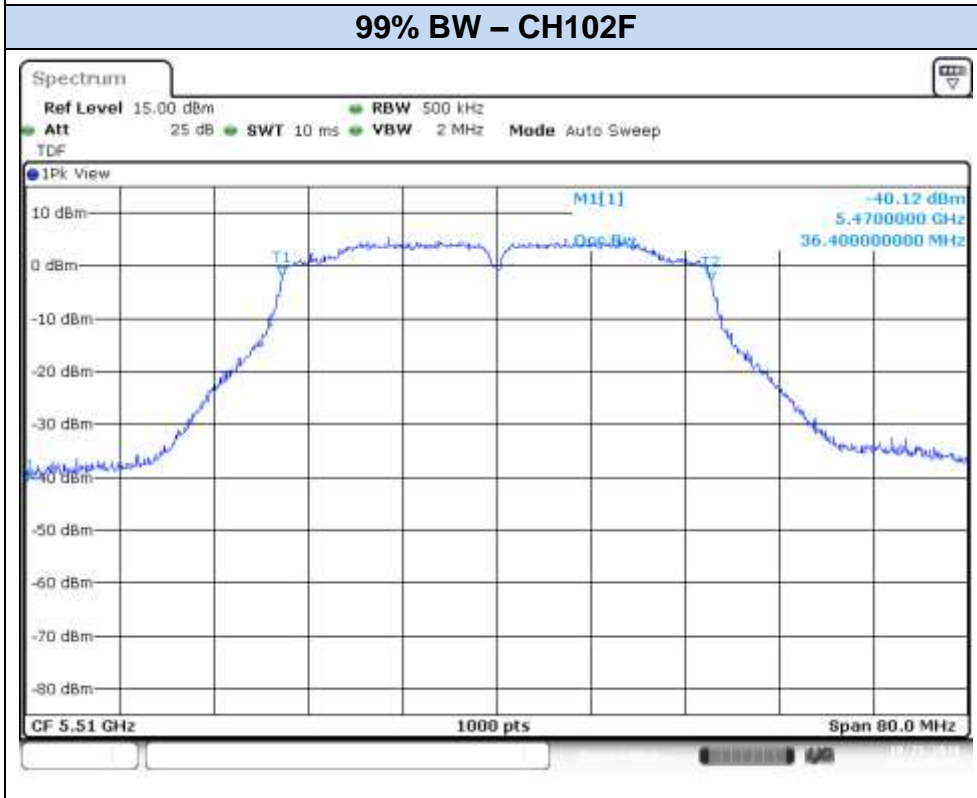
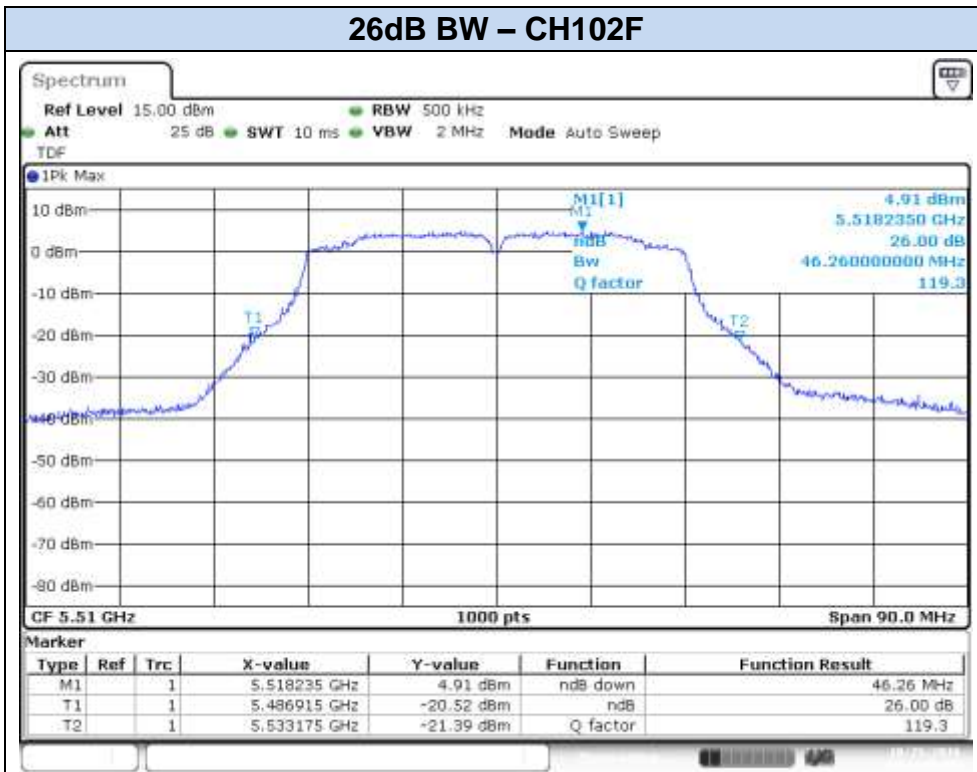

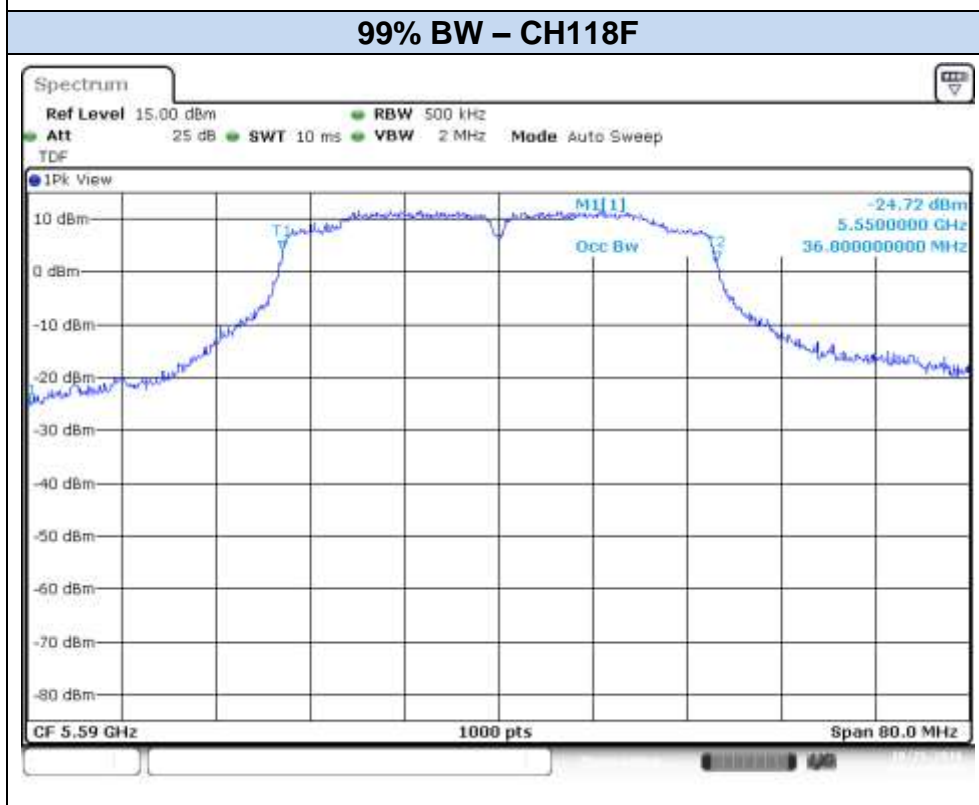
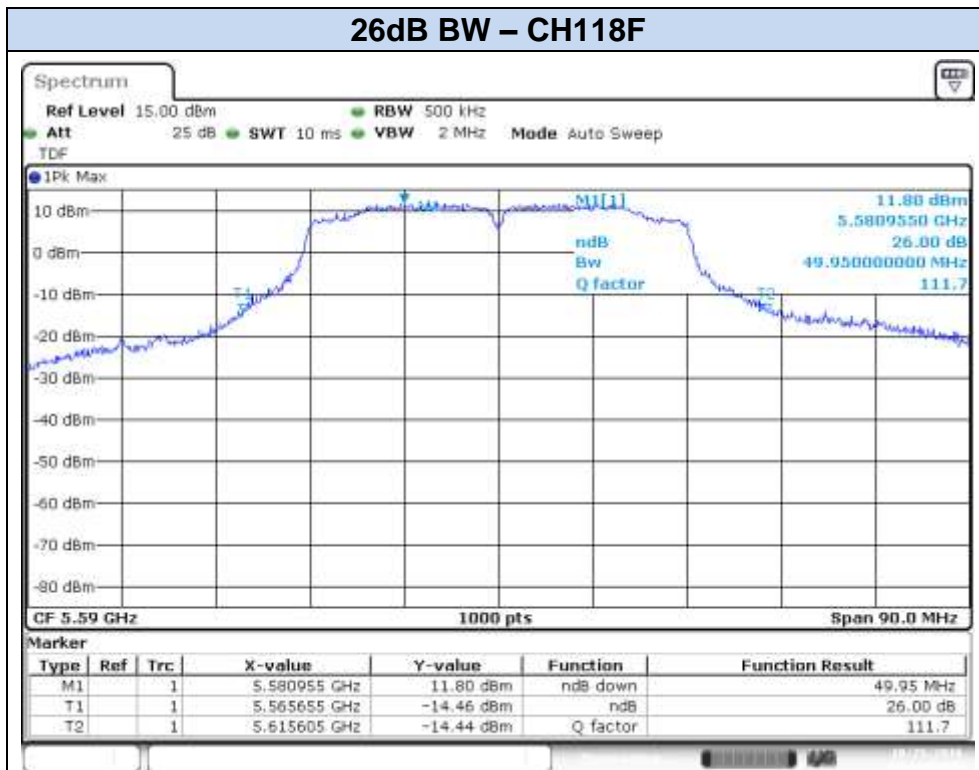

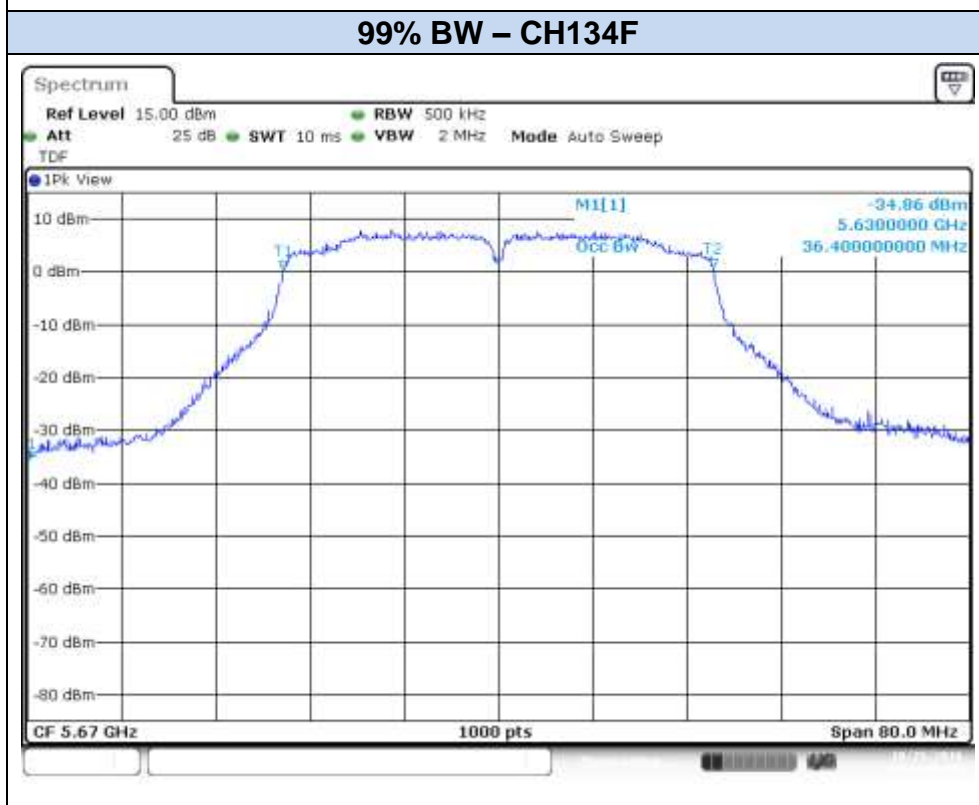
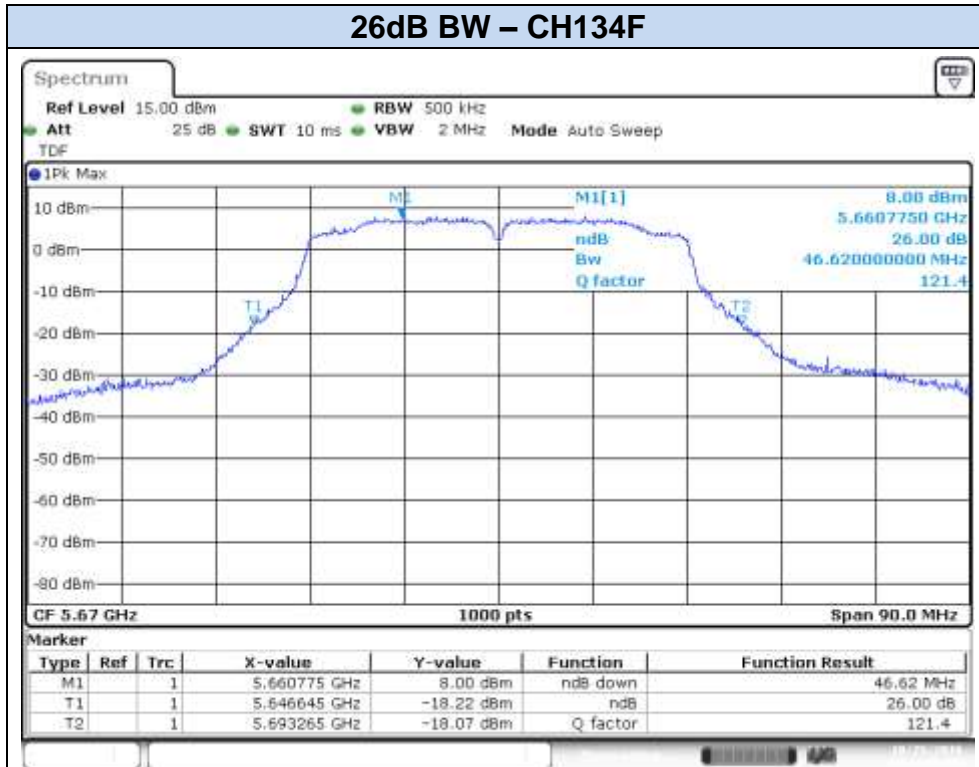

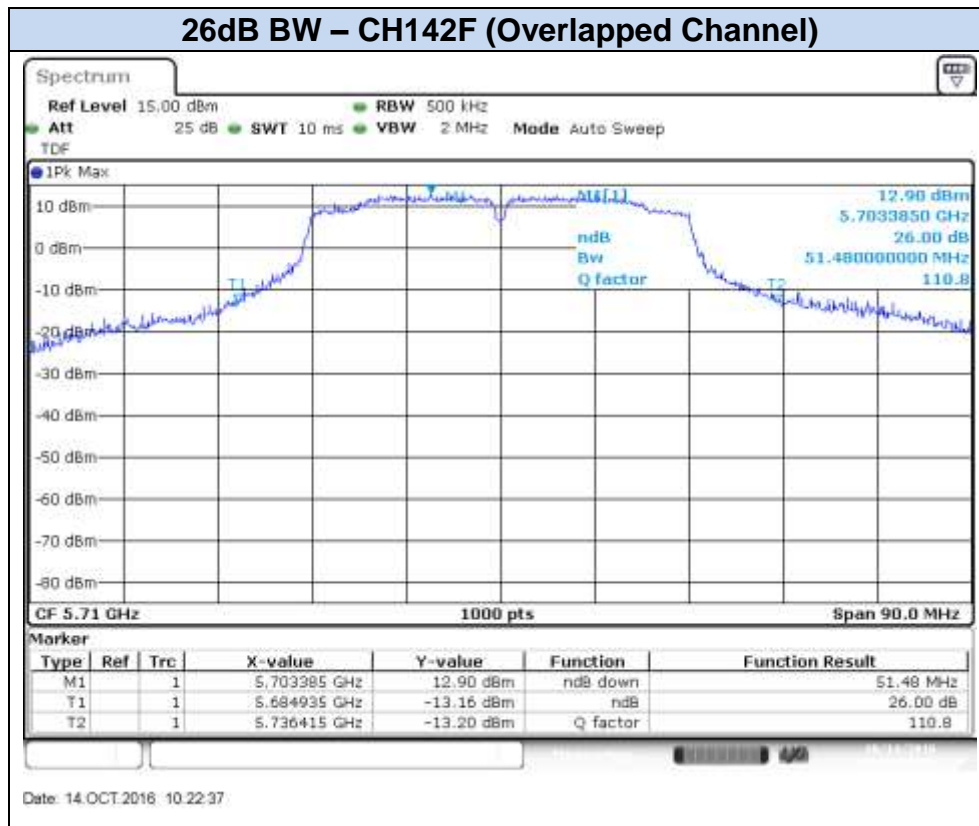



**802.11n40, HT8 (MIMO) – Chain B**

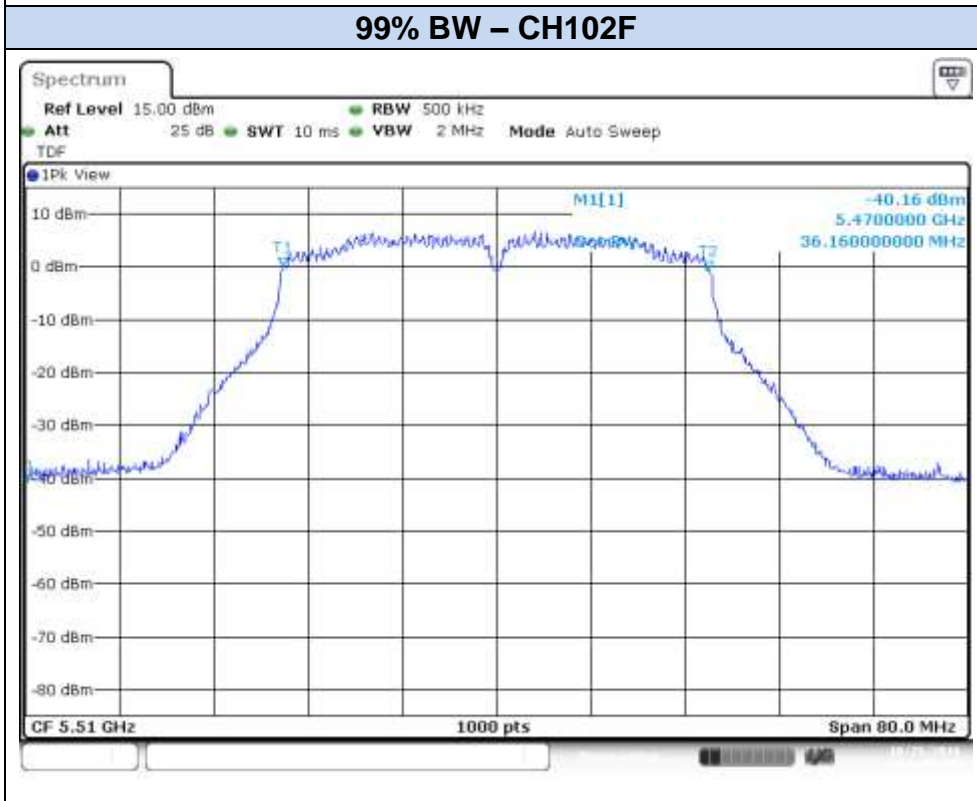
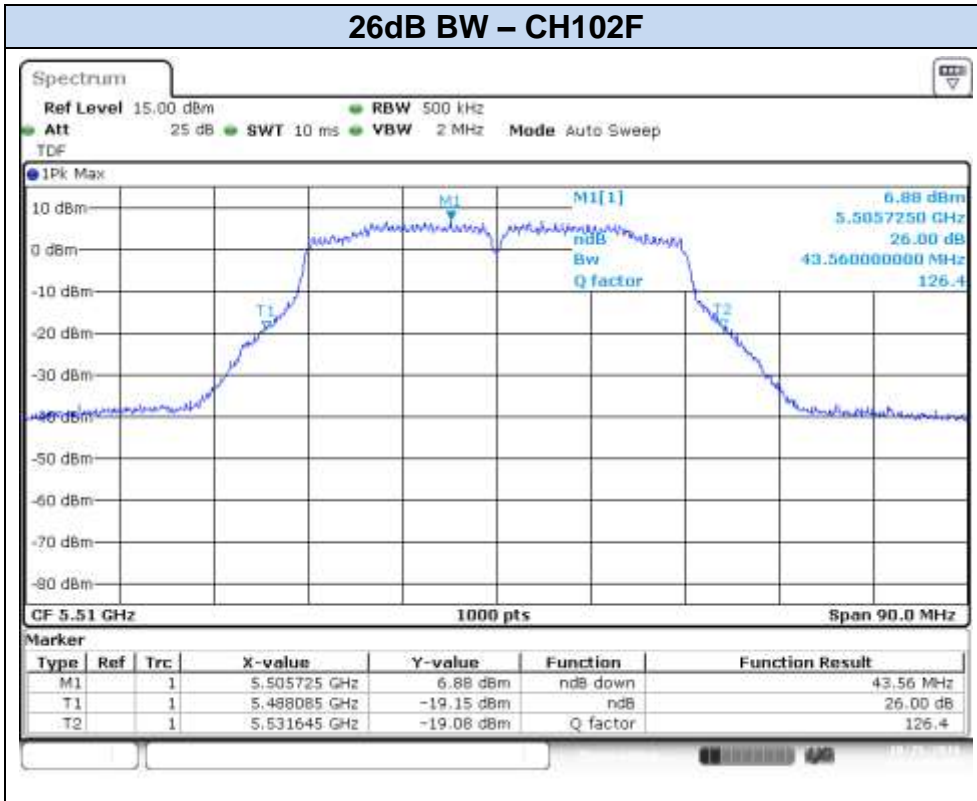



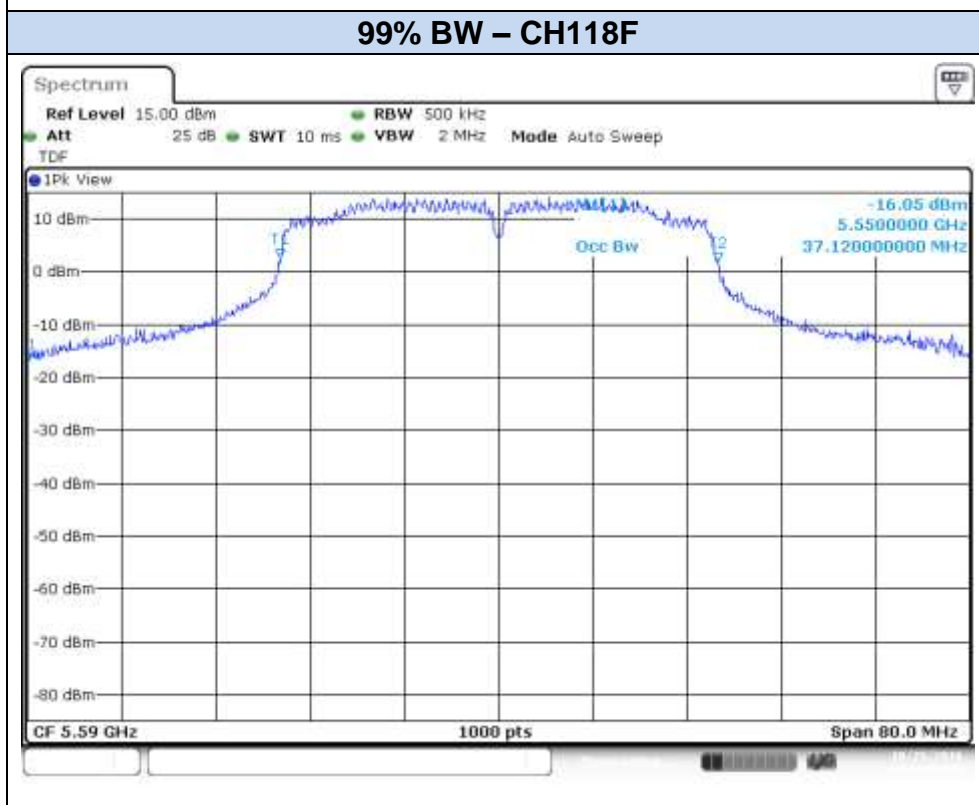
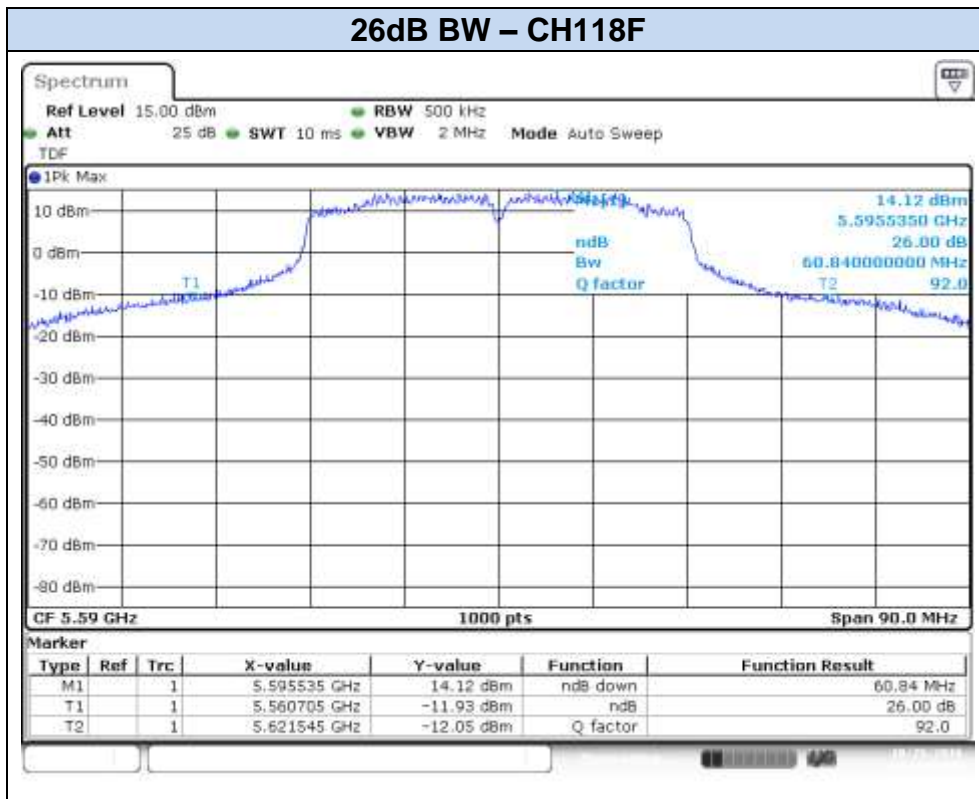

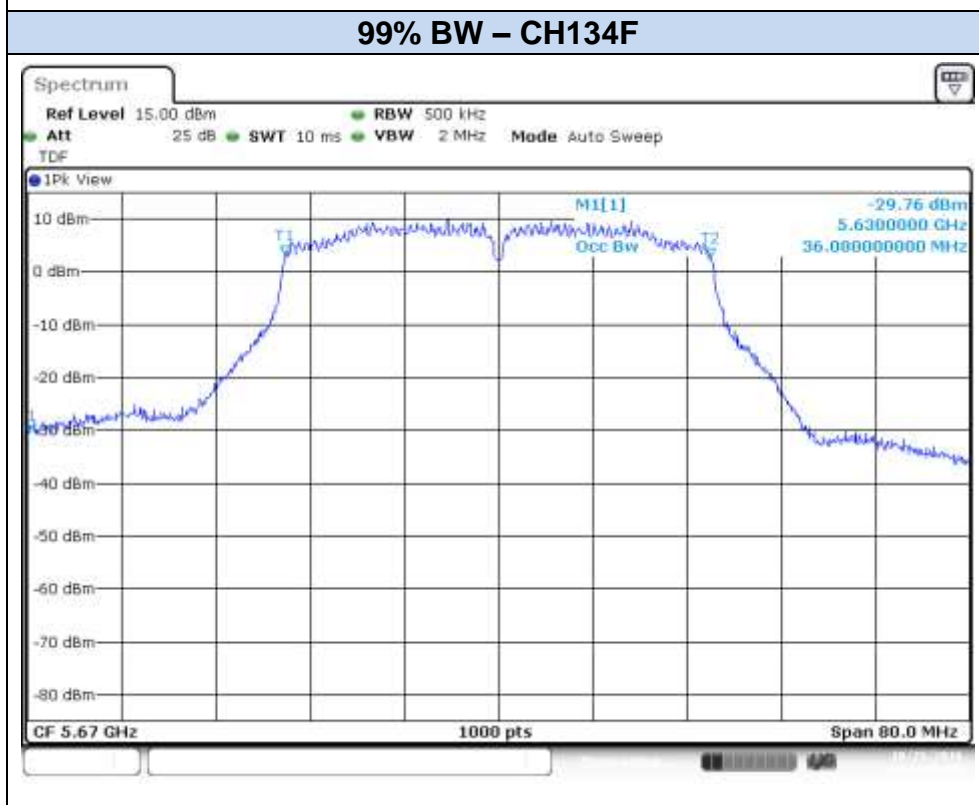
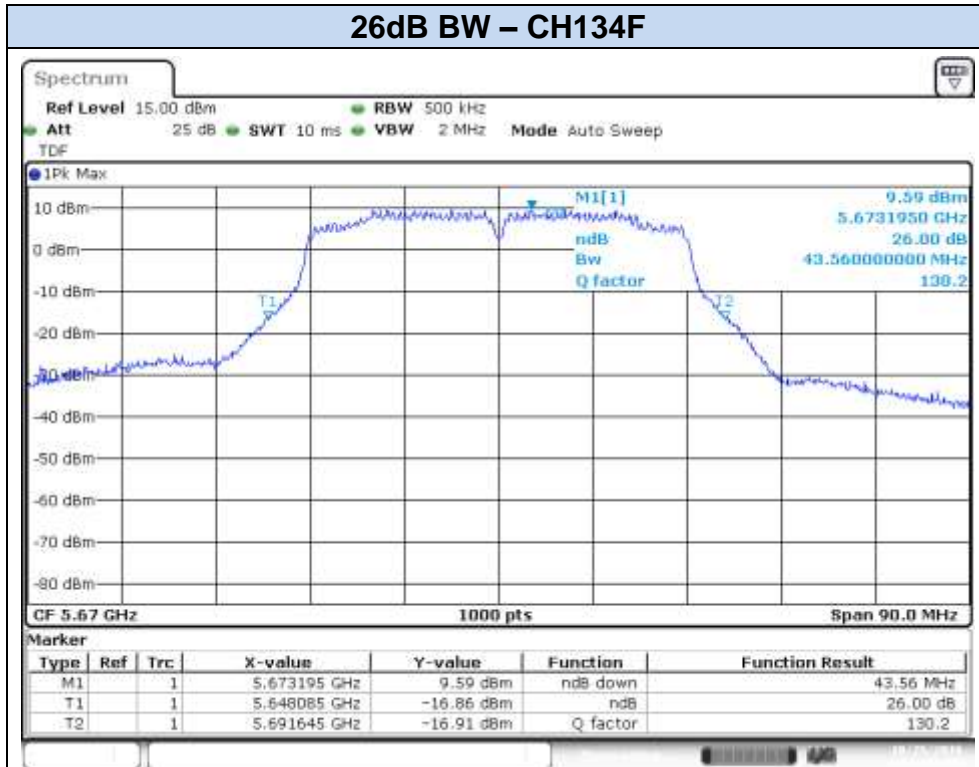

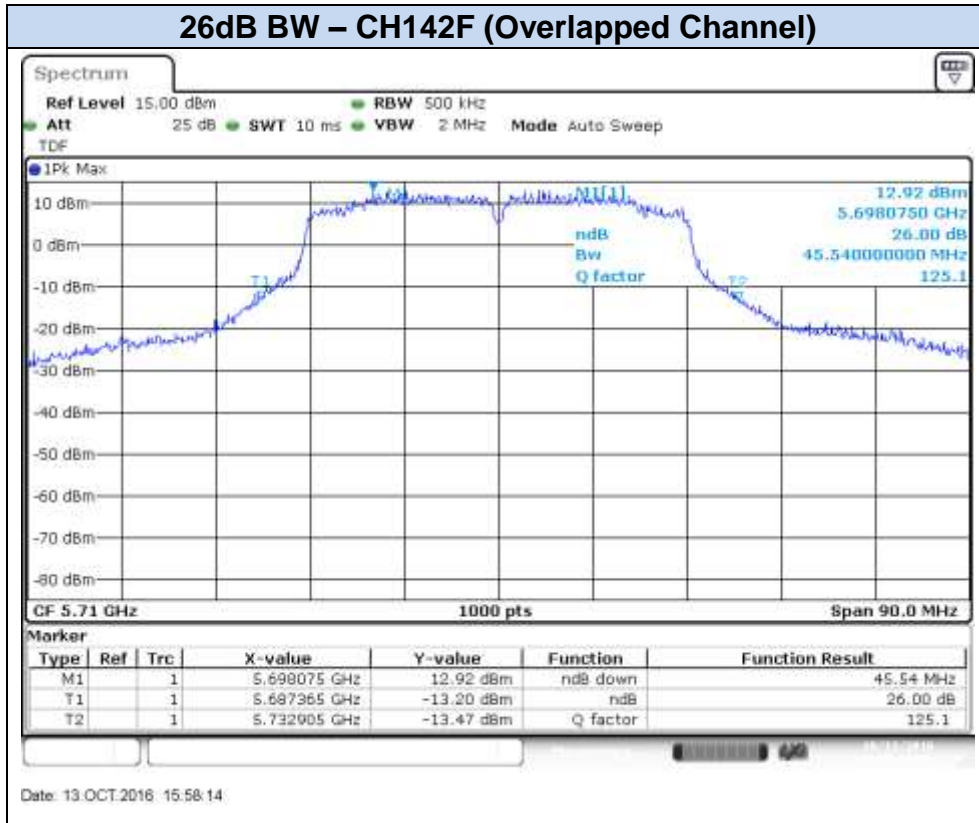

**802.11ac80, VHT0 (SISO) – Chain A**

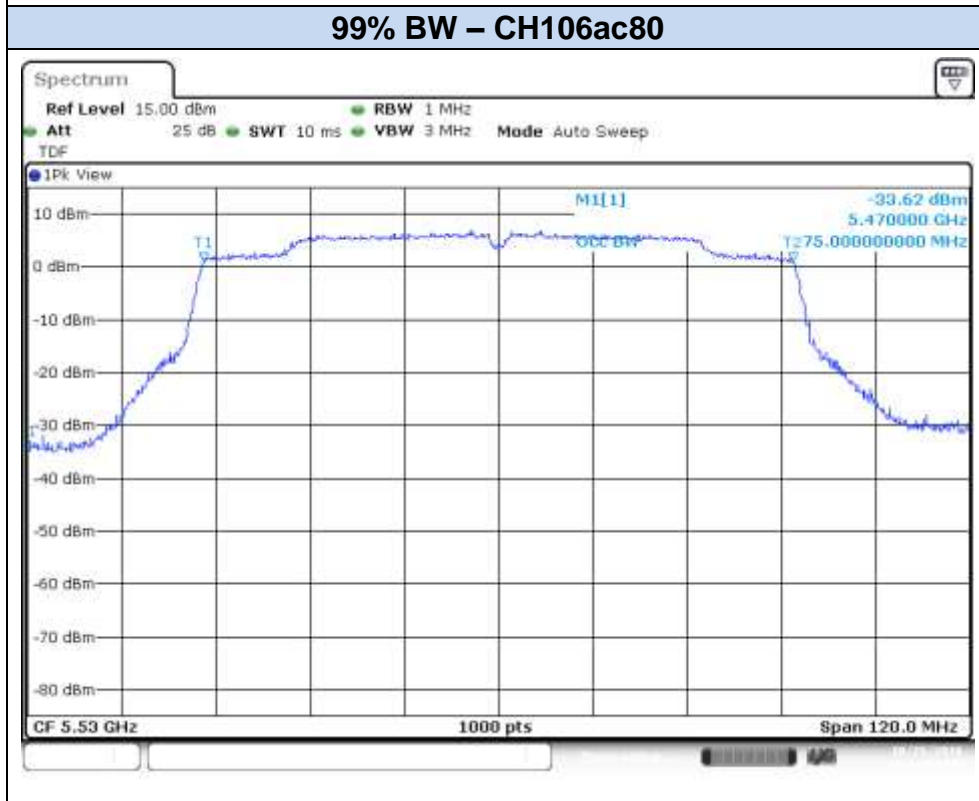

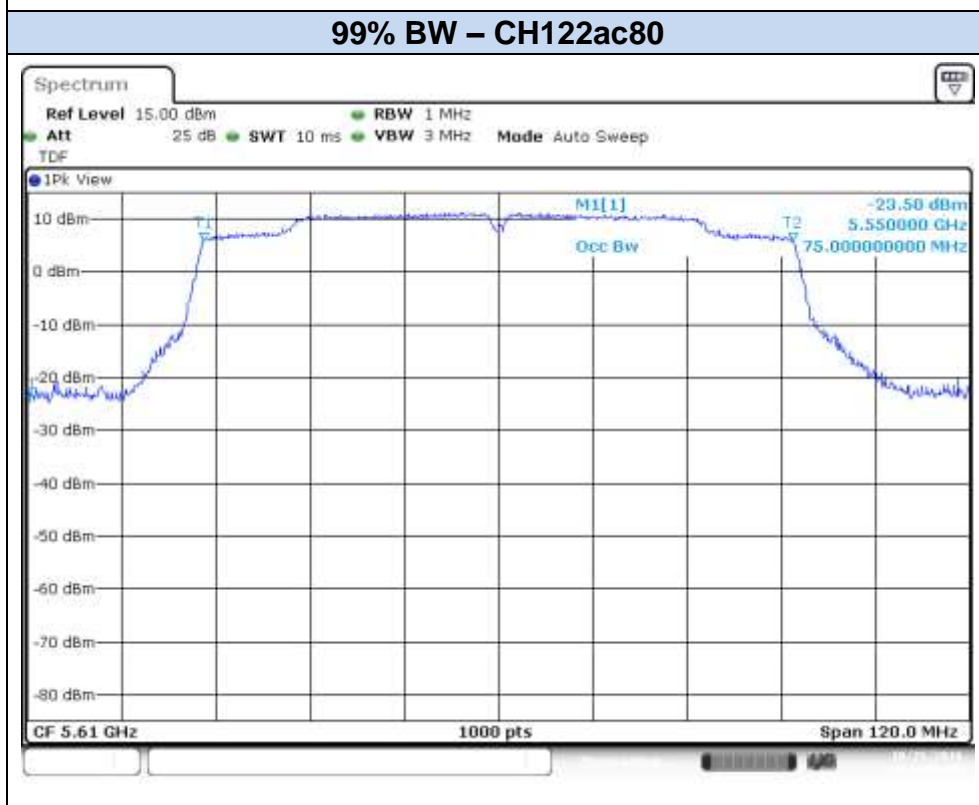
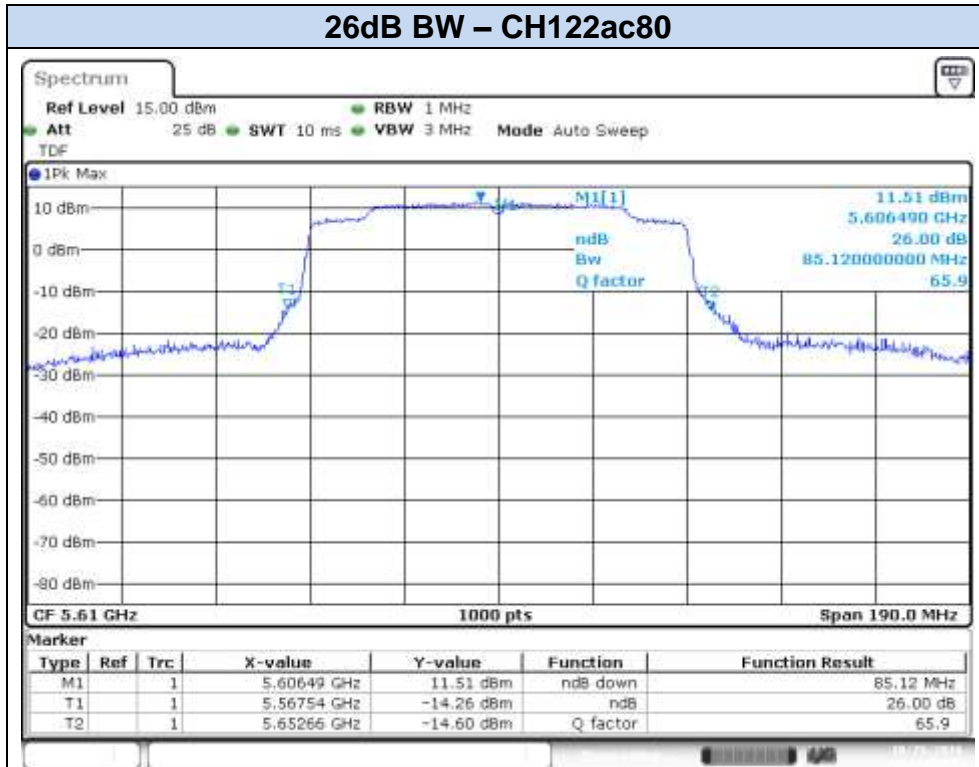

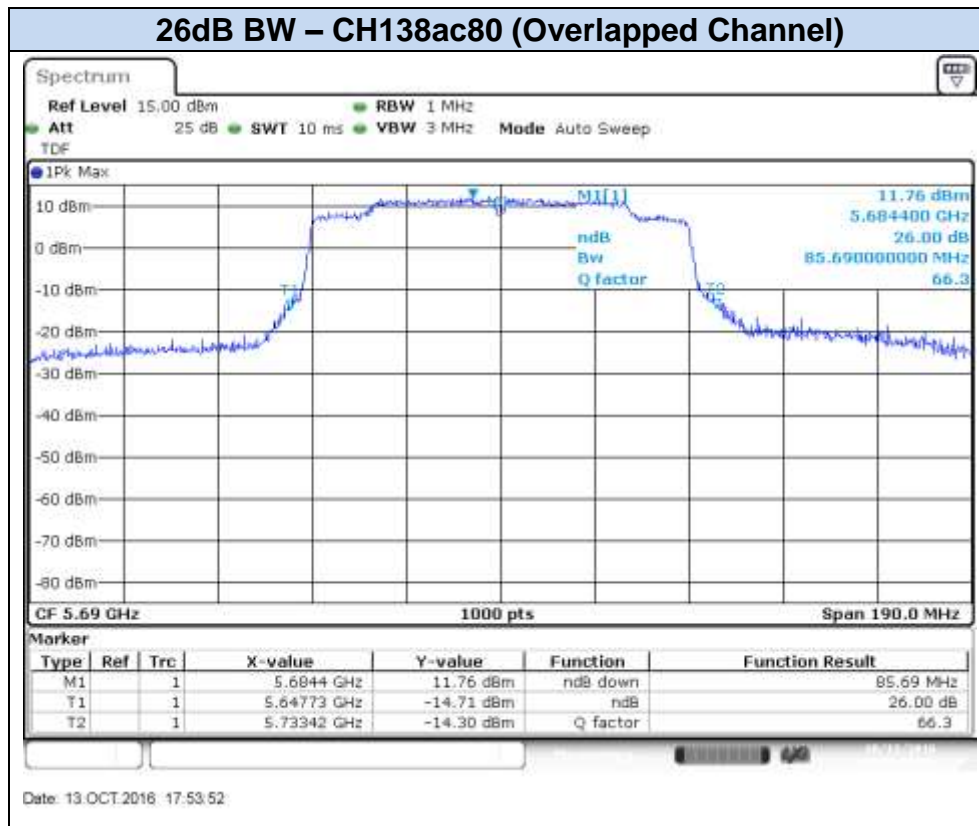

**802.11ac80, VHT0 (SISO) – Chain B**

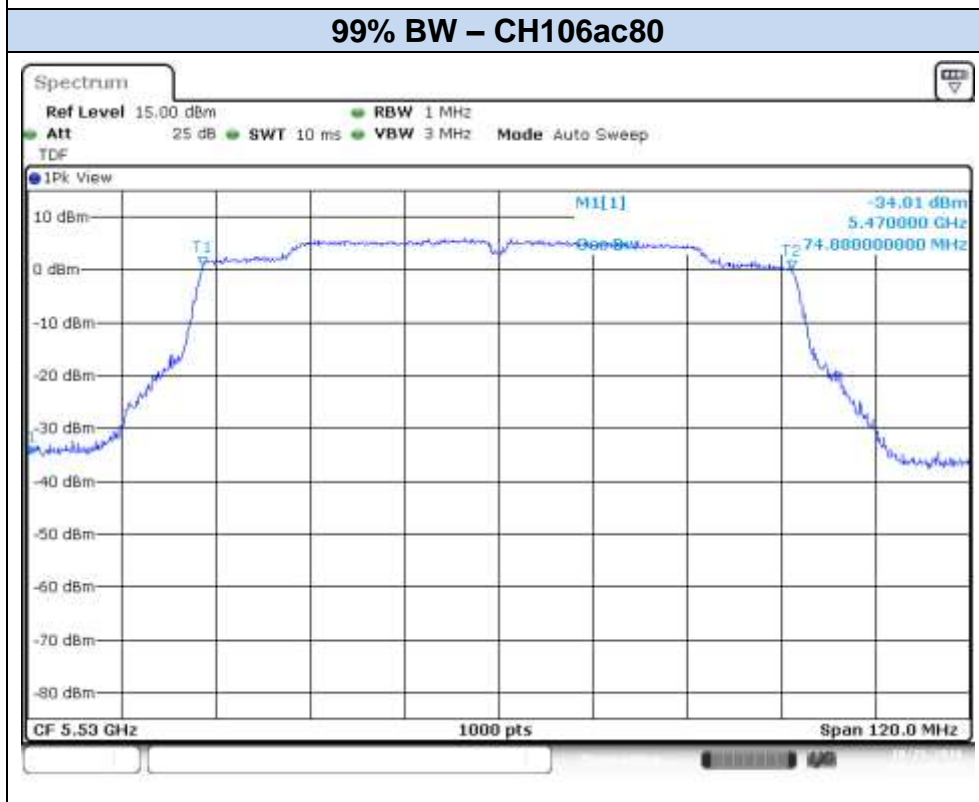
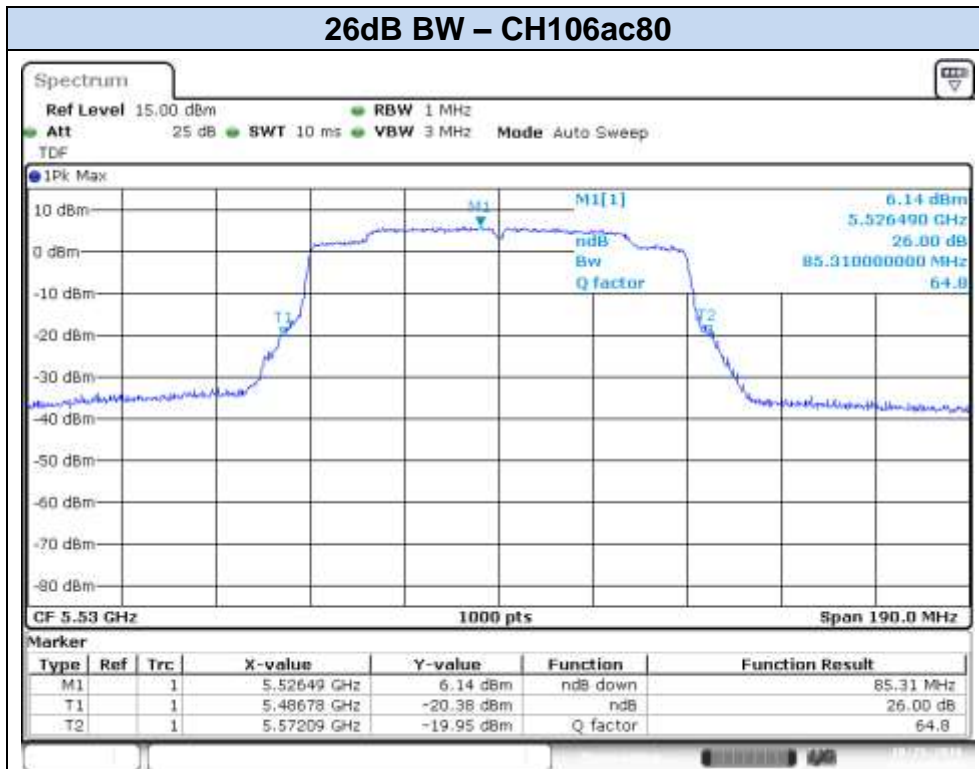



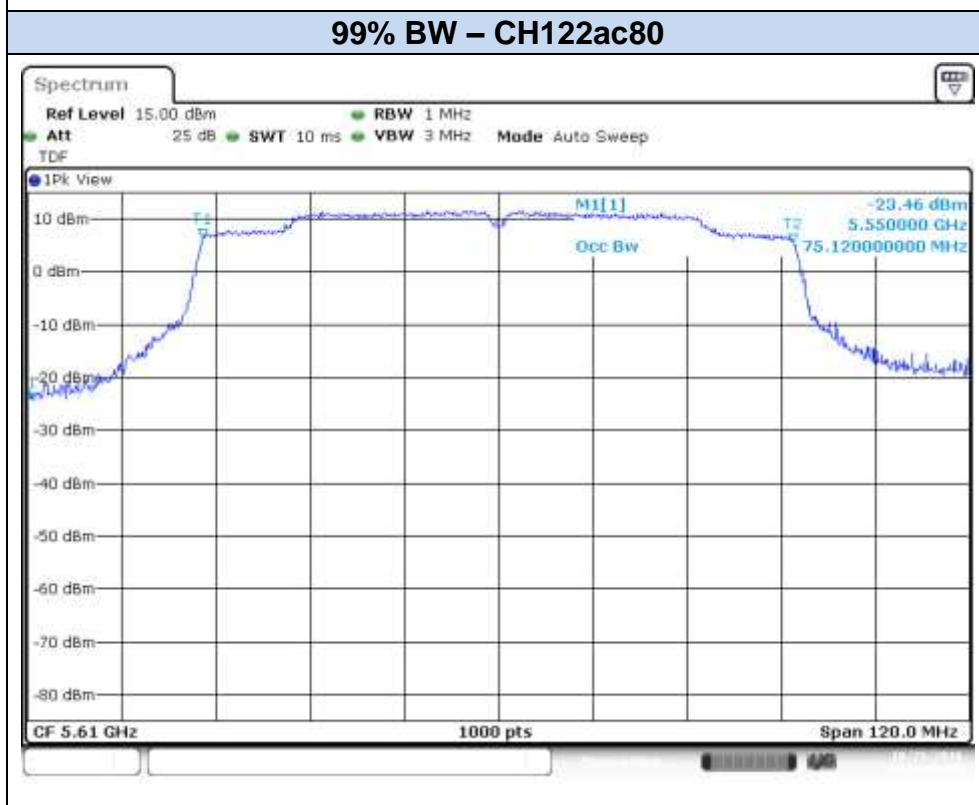



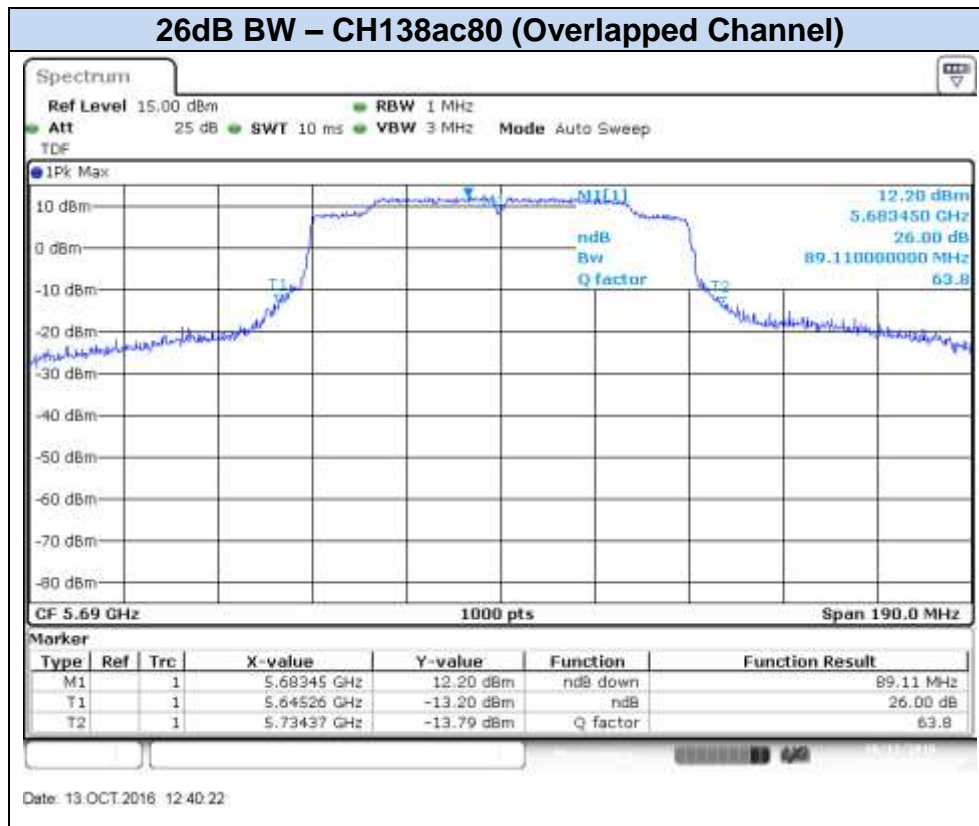

**802.11ac80, VHT0 (MIMO) – Chain A**

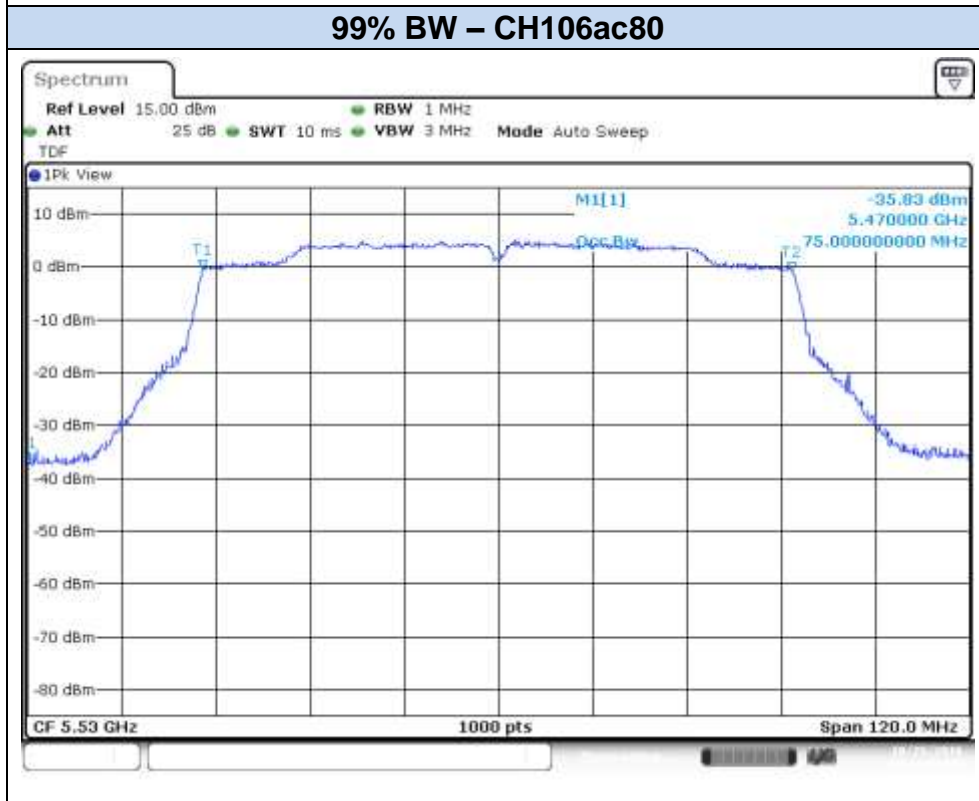
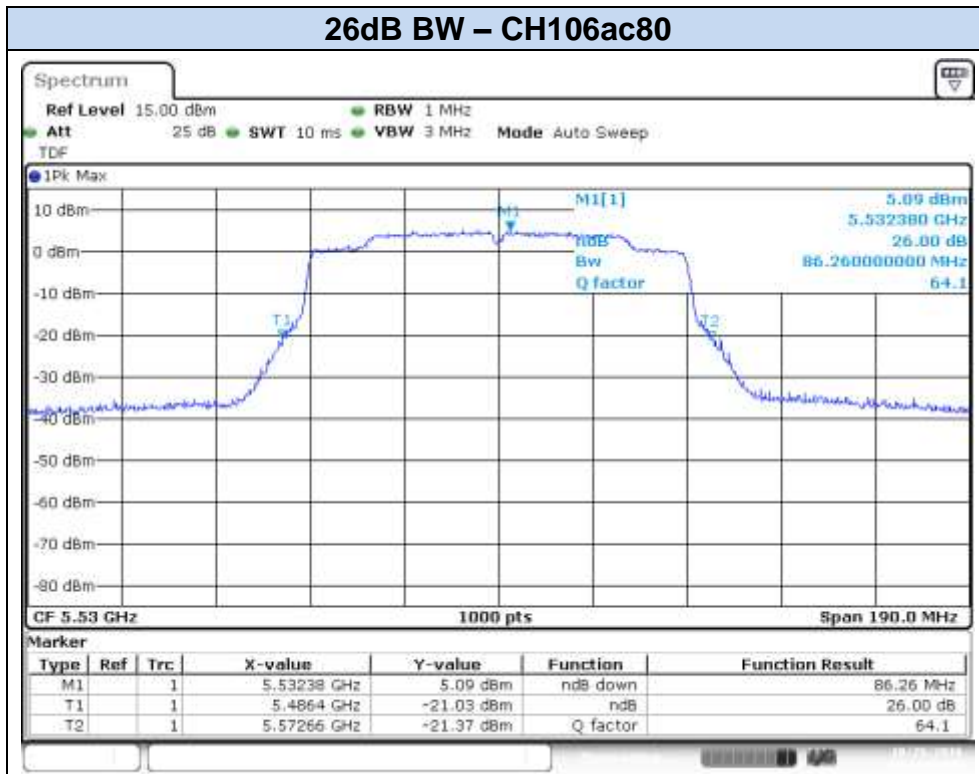

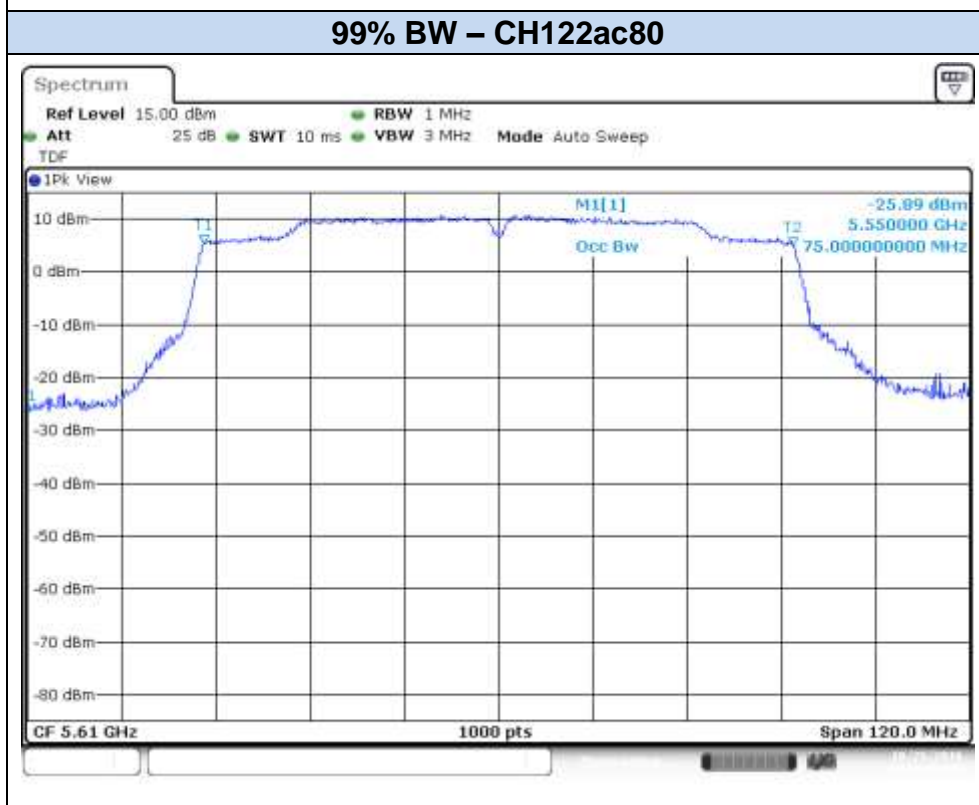
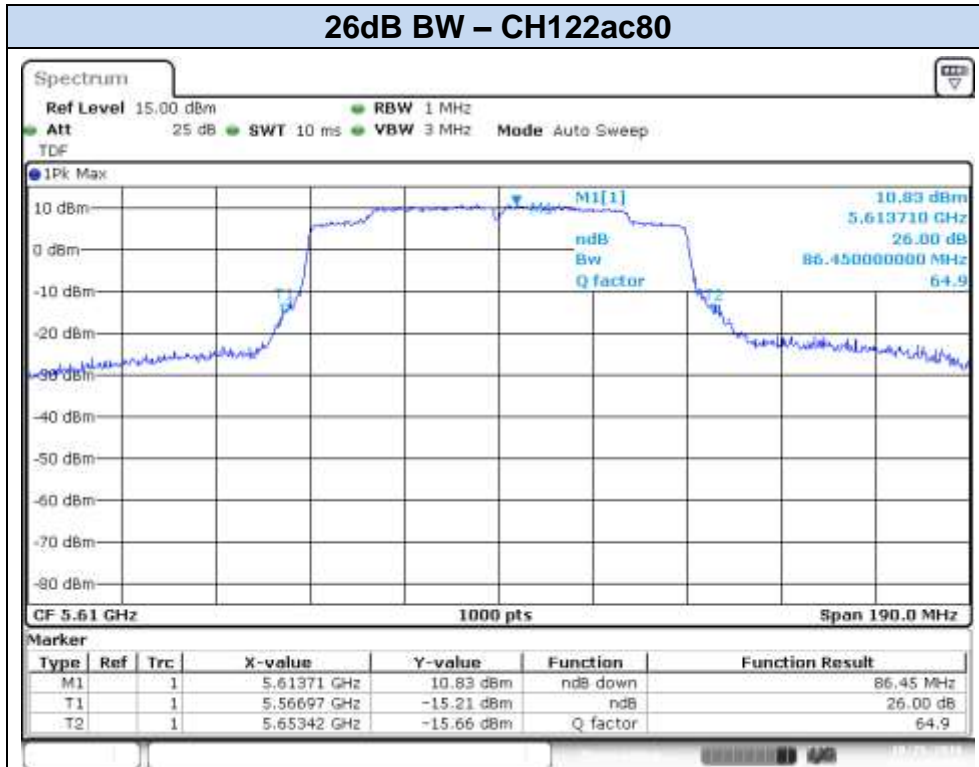

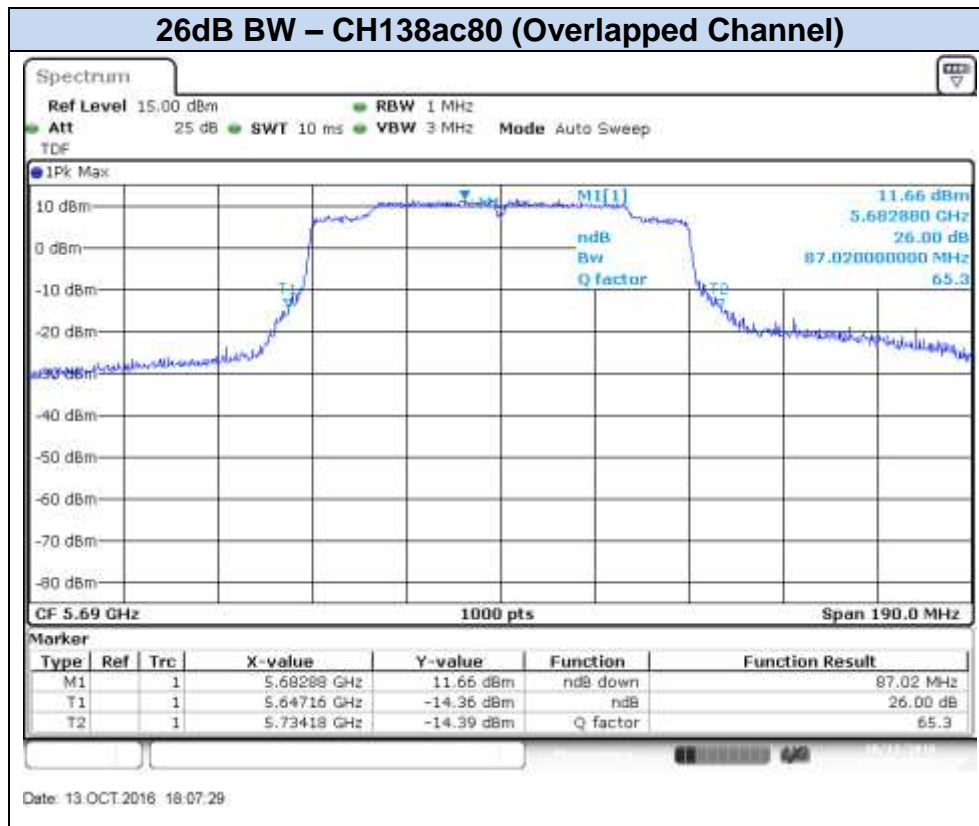

**802.11ac80, VHT0 (MIMO) – Chain B**

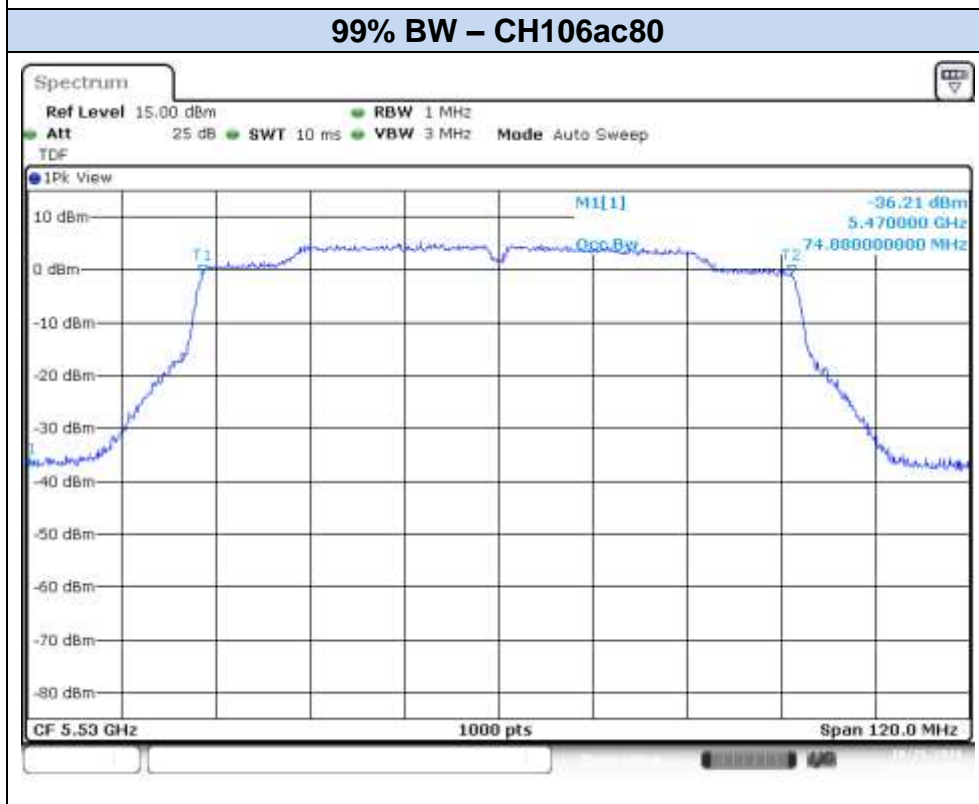
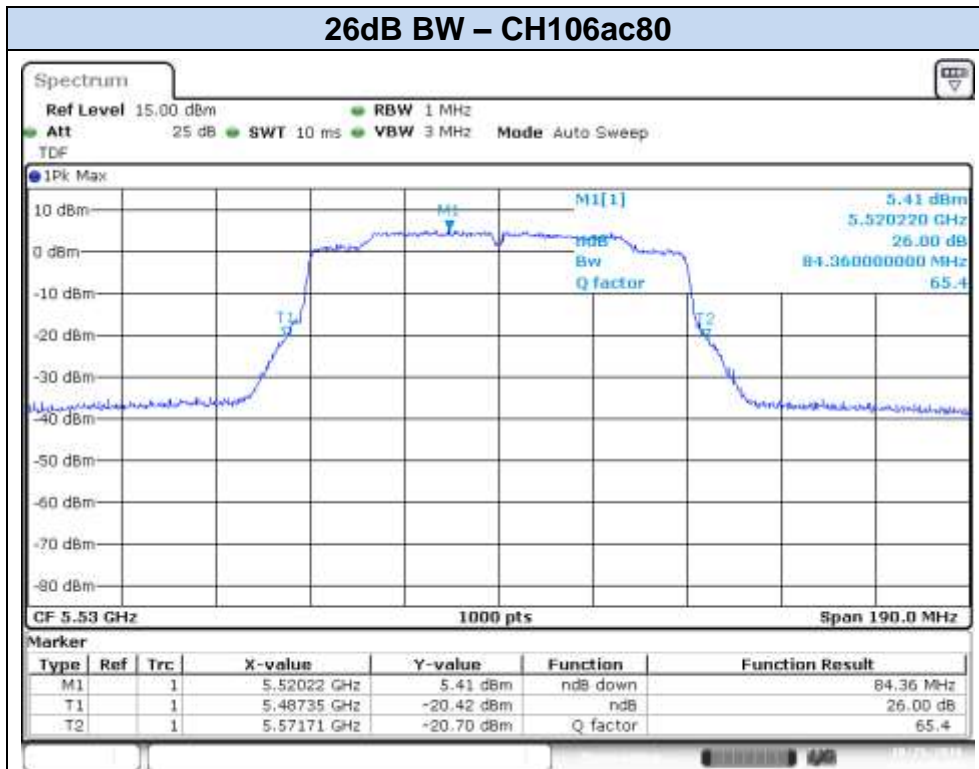

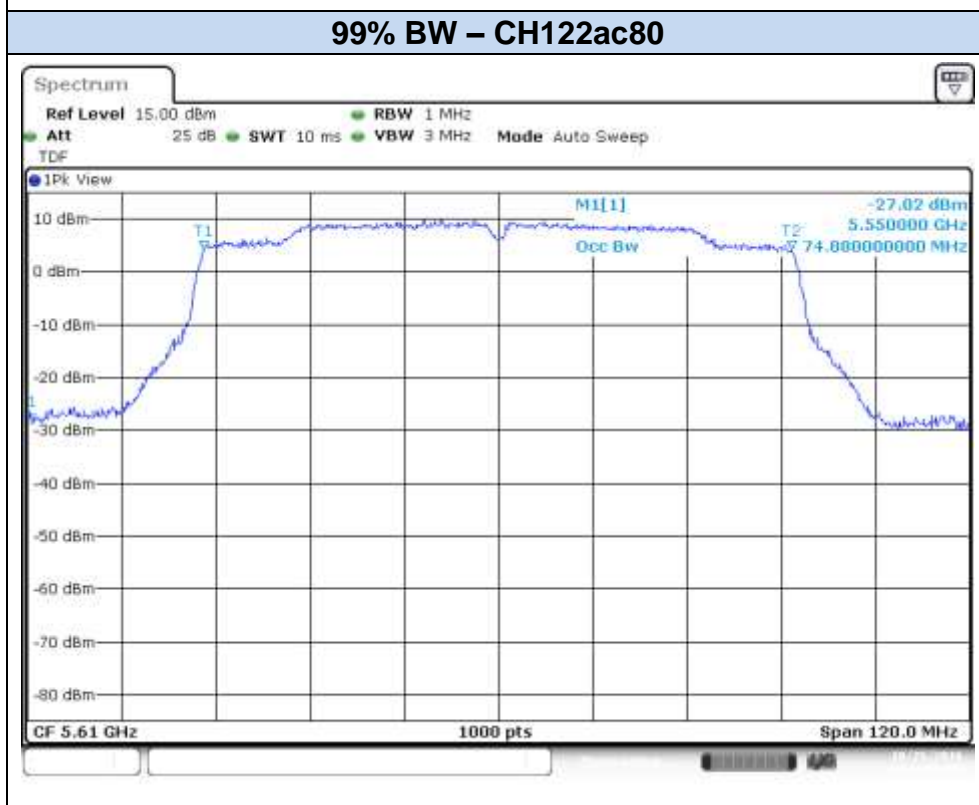
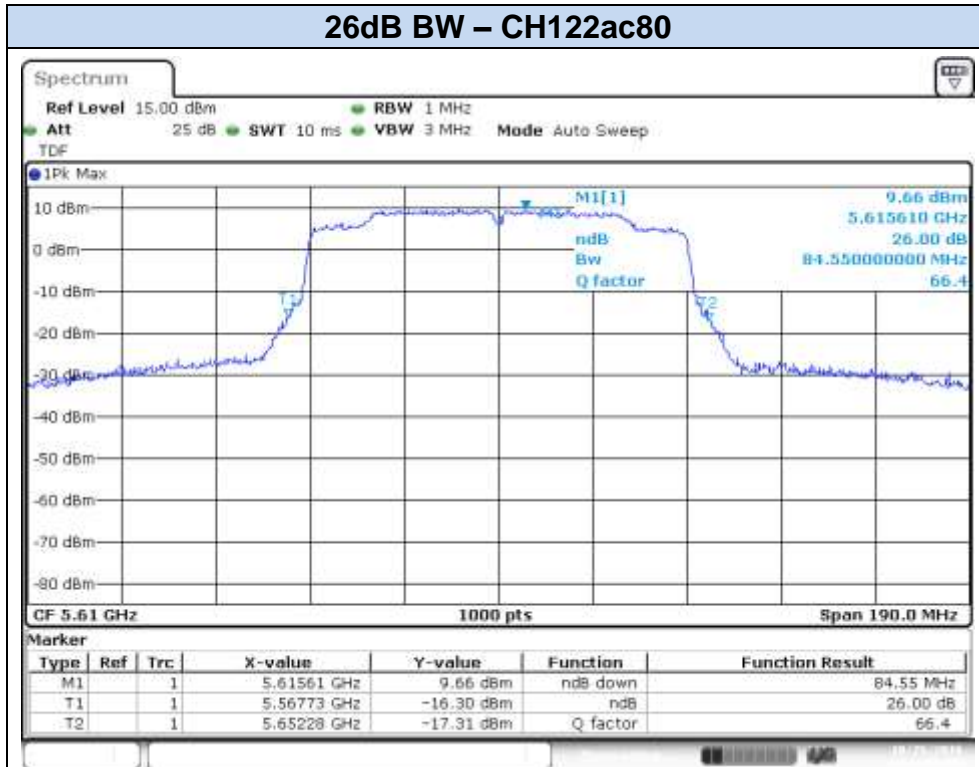

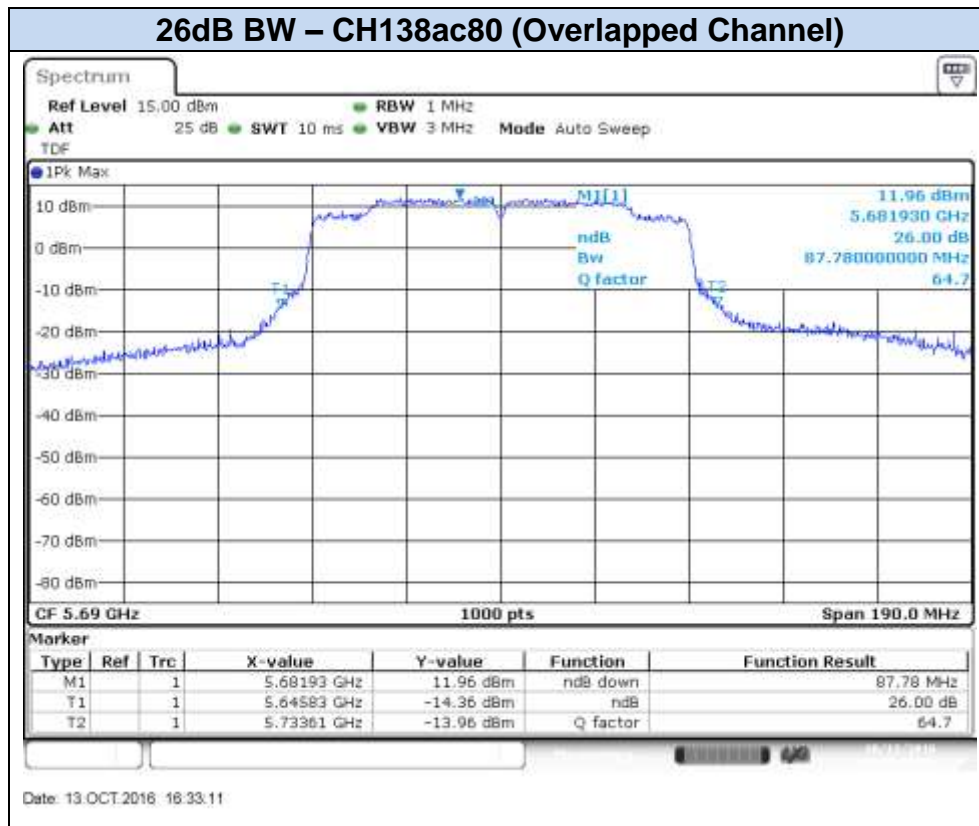

## B.2 Power Limits. Maximum Output power & Peak power spectral density

### Test limits:

Part	Limits
FCC 15.407 (a) (2)	For the 5.25–5.35 GHz and 5.47–5.725 GHz bands, the maximum conducted output power over the frequency bands of operation shall not exceed the lesser of 250 mW or $11 \text{ dBm} + 10 \log B$ , where B is the 26 dB emission bandwidth in megahertz. In addition, the peak power spectral density shall not exceed 11 dBm in any 1 megahertz band.
RSS-247 Clause 6.2.2 (1)	<p>The maximum conducted output power shall not exceed 250 mW or <math>11 + 10 \log_{10} B</math>, dBm, whichever is less. The power spectral density shall not exceed 11 dBm in any 1.0 MHz band.</p> <p>The maximum e.i.r.p. shall not exceed 1.0 W or <math>17 + 10 \log_{10} B</math>, dBm, whichever is less. B is the 99% emission bandwidth in megahertz. Note that devices with a maximum e.i.r.p. greater than 500 mW shall implement TPC in order to have the capability to operate at least 6 dB below the maximum permitted e.i.r.p. of 1 W.</p>

### Test procedure:

The Maximum Conducted Output Power was measured using the channel integration method according to point E) 2) e) (Method SA-2 Alternative) of KDB 789033 D02.

The maximum power spectral density (PSD) was measured using the method according to point F) (Method SA-2 Alternative) of KDB 789033 D02.

In the measure-and-sum approach for MIMO mode, the conducted emission level (e.g., transmit power or power in specified bandwidth) is measured at each antenna port. The measured results at the various antenna ports are then summed mathematically in linear power units to determine the total emission level from the device.

The EIRP power (dBm) is calculated by adding the declared maximum antenna gain to the measured conducted power.



The setup below was used to measure the maximum conducted output power and power spectral density. The antenna terminal of the EUT is connected to the spectrum analyzer through an attenuator, and the spectrum analyzer reading is compensated to include the RF path loss.

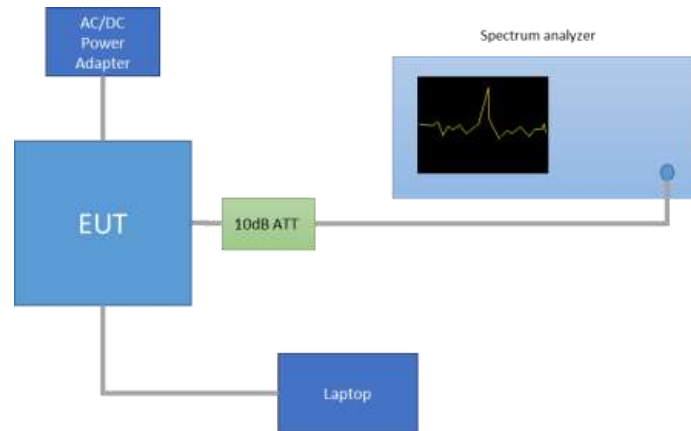

The declared maximum antenna gain is 5dBi.

For the overlapped channels between U-NII-2C and U-NII-3, and according to FCC KDB 644545 D03, the power is computed based on the portion of the emission bandwidth contained within that band. This rule is only applicable for those channels marked as overlapped.

**Results tables:****Duty cycle**

Mode	Rate	Antenna	Transmission Duration [ms]	Transmission Period [ms]	Duty Cycle [%]
802.11a	6Mbps	SISO-A	2.03	2.07	98.0%
		SISO-B	2.04	2.07	98.2%
802.11n20	HT0	SISO-A	1.90	1.93	98.4%
		SISO-B	1.90	1.94	98.2%
	HT8	MIMO-A	0.97	1.01	96.1%
		MIMO-B	0.97	1.01	96.1%
802.11n40	HT0	SISO-A	0.93	0.96	96.5%
		SISO-B	0.94	0.97	96.8%
	HT8	MIMO-A	0.49	0.53	92.3%
		MIMO-B	0.49	0.53	92.1%
802.11ac80	VHT0	SISO-A	0.46	0.49	93.5%
		SISO-B	0.45	0.49	93.2%
		MIMO-A	0.26	0.29	87.3%
		MIMO-B	0.25	0.29	86.6%

**Maximum output power – U-NII-2C Channels**

Mode	Rate	Channel	Freq. [MHz]	Antenna	Average Cond. Output Power [dBm]	Max.* Cond. Output Power [dBm]	Max.* Cond. Output Power [mW]	Max. EIRP [dBm]	
802.11a	6Mbps	100	5500	SISO CHAIN A	17.16	17.16	52.00	22.16	
				SISO CHAIN B	17.69	17.69	58.75	22.69	
		120	5600	SISO CHAIN A	19.79	19.79	95.28	24.79	
				SISO CHAIN B	20.04	20.04	100.93	25.04	
		140	5700	SISO CHAIN A	18.65	18.65	73.28	23.65	
				SISO CHAIN B	16.95	16.95	49.55	21.95	
802.11n20	HT0	100	5500	SISO CHAIN A	17.11	17.11	51.40	22.11	
				SISO CHAIN B	17.57	17.57	57.02	22.56	
		120	5600	SISO CHAIN A	21.16	21.16	130.62	26.16	
				SISO CHAIN B	20.44	20.44	110.66	25.44	
		140	5700	SISO CHAIN A	18.57	18.57	71.94	23.57	
				SISO CHAIN B	16.83	16.83	48.19	21.83	
	HT8	100	5500	MIMO CHAIN A	14.58	14.75	29.88	19.75	
				MIMO CHAIN B	14.80	14.97	31.43	19.97	
				Combined A+B	17.70	17.88	61.31	22.88	
		120	5600	MIMO CHAIN A	17.72	17.89	61.58	22.89	
				MIMO CHAIN B	18.24	18.41	69.39	23.41	
				Combined A+B	21.00	21.17	130.98	26.17	
	140	5700	MIMO CHAIN A	14.17	14.34	27.19	19.34		
			MIMO CHAIN B	14.92	15.09	32.31	20.09		
			Combined A+B	17.57	17.75	59.50	22.75		
	802.11n40	HT0	102F	5510	SISO CHAIN A	15.16	15.31	33.99	20.31
					SISO CHAIN B	13.71	13.85	24.27	18.85
			118F	5590	SISO CHAIN A	20.82	20.97	125.11	25.97
SISO CHAIN B					20.39	20.53	112.98	25.53	
134F			5670	SISO CHAIN A	17.91	18.06	64.02	23.06	
				SISO CHAIN B	17.18	17.32	53.95	22.32	
HT8		102F	5510	MIMO CHAIN A	13.23	13.58	22.80	18.58	
				MIMO CHAIN B	13.09	13.45	22.13	18.45	
				Combined A+B	16.17	16.53	44.93	21.53	
		118F	5590	MIMO CHAIN A	20.09	20.44	110.66	25.44	
				MIMO CHAIN B	20.67	21.03	126.75	26.03	
				Combined A+B	23.40	23.76	237.41	28.76	
		134F	5670	MIMO CHAIN A	16.04	16.39	43.55	21.39	
				MIMO CHAIN B	16.15	16.51	44.77	21.51	
				Combined A+B	19.11	19.46	88.32	24.46	

Mode	Rate	Channel	Freq. [MHz]	Antenna	Average Cond. Output Power [dBm]	Max.* Cond. Output Power [dBm]	Max.* Cond. Output Power [mW]	Max. EIRP [dBm]
802.11ac80	VHT0	106ac80	5530	SISO CHAIN A	13.94	14.23	26.50	19.23
				SISO CHAIN B	13.31	13.62	22.99	18.62
				MIMO CHAIN A	11.99	12.58	18.12	17.58
				MIMO CHAIN B	11.62	12.24	16.76	17.24
				Combined A+B	14.82	15.43	34.88	20.43
	122ac80	5610	SISO CHAIN A	18.80	19.09	81.15	24.09	
			SISO CHAIN B	19.04	19.35	86.01	24.35	
			MIMO CHAIN A	17.77	18.36	68.57	23.36	
			MIMO CHAIN B	16.34	16.96	49.69	21.96	
			Combined A+B	20.12	20.73	118.27	25.73	

\* Maximum values are the duty cycle compensated values calculated from the average (measured) values

Max Value

Min Value

**Maximum output power – Overlapped channels between U-NII-2C and U-NII-3**

Mode	Rate	Channel	Freq. [MHz]	Antenna	Average Cond. Output Power - UNII-2C [dBm]	Max.* Cond. Output Power - UNII-2C [dBm]	Max.* Cond. Output Power - UNII-2C [mW]	Max.* EIRP UNII2C [dBm]
802.11n20	HT0	144	5720	SISO CHAIN A	19.65	19.72	93.77	24.72
				SISO CHAIN B	19.62	19.70	93.30	24.70
	HT8			MIMO CHAIN A	18.18	18.35	68.46	23.35
				MIMO CHAIN B	17.71	17.88	61.42	22.88
	Combined A+B			20.96	21.46	129.98	26.14	
802.11n40	HT0	142F	5710	SISO CHAIN A	20.00	20.15	103.58	25.15
				SISO CHAIN B	20.16	20.30	107.15	25.30
	HT8			MIMO CHAIN A	19.75	20.09	102.10	25.09
				MIMO CHAIN B	19.45	19.81	95.71	24.81
	Combined A+B			22.61	22.96	197.80	27.96	
802.11ac80	VHT0	138ac80	5690	SISO CHAIN A	19.82	20.11	102.64	25.11
				SISO CHAIN B	19.84	20.15	103.40	25.15
				MIMO CHAIN A	19.53	20.12	102.84	25.12
				MIMO CHAIN B	19.50	20.12	102.87	25.12
				Combined A+B	22.53	23.13	205.71	28.13

\* Maximum values are the duty cycle compensated values calculated from the average (measured) values

Max Value

Min Value

**Maximum Power Spectral Density (PSD) – U-NII-2C channels**

Mode	Rate	Channel	Freq. [MHz]	Antenna	Average conducted PSD [dBm/MHz]	Maximum* conducted PSD [dBm/MHz]	
802.11a	6Mbps	100	5500	SISO CHAIN A	6.29	6.29	
				SISO CHAIN B	6.82	6.82	
		120	5600	SISO CHAIN A	8.89	8.89	
				SISO CHAIN B	9.16	9.16	
		140	5700	SISO CHAIN A	7.81	7.81	
				SISO CHAIN B	6.04	6.04	
802.11n20	HT0	100	5500	SISO CHAIN A	6.05	6.05	
				SISO CHAIN B	6.55	6.55	
		120	5600	SISO CHAIN A	10.04	10.04	
				SISO CHAIN B	9.31	9.31	
		140	5700	SISO CHAIN A	7.53	7.53	
				SISO CHAIN B	5.75	5.75	
	HT8	100	5500	MIMO CHAIN A	3.53	3.70	
				MIMO CHAIN B	3.73	3.90	
				Combined A+B	6.64	6.82	
		120	5600	MIMO CHAIN A	6.67	6.84	
				MIMO CHAIN B	7.14	7.31	
				Combined A+B	9.92	10.10	
	140	5700	MIMO CHAIN A	3.13	3.30		
			MIMO CHAIN B	3.86	4.03		
			Combined A+B	6.58	6.75		
	802.11n40	HT0	102F	5510	SISO CHAIN A	0.79	0.94
					SISO CHAIN B	-0.59	-0.45
			118F	5590	SISO CHAIN A	6.46	6.61
SISO CHAIN B					6.04	6.18	
134F			5670	SISO CHAIN A	3.55	3.70	
				SISO CHAIN B	2.83	2.97	
HT8		102F	5510	MIMO CHAIN A	-1.17	-0.82	
				MIMO CHAIN B	-1.21	-0.85	
				Combined A+B	1.82	2.18	
		118F	5590	MIMO CHAIN A	5.71	6.06	
				MIMO CHAIN B	6.31	6.67	
				Combined A+B	9.03	9.39	
134F	5670	MIMO CHAIN A	1.72	2.07			
		MIMO CHAIN B	1.81	2.17			
		Combined A+B	4.78	5.13			

Mode	Rate	Channel	Freq. [MHz]	Antenna	Average conducted PSD [dBm/MHz]	Maximum* conducted PSD [dBm/MHz]
802.11ac80	VHT0	106ac80	5530	SISO CHAIN A	-3.18	-2.89
				SISO CHAIN B	-3.76	-3.45
				MIMO CHAIN A	-5.01	-4.42
				MIMO CHAIN B	-5.38	-4.76
				Combined A+B	-2.18	-1.57
	122ac80	5610	SISO CHAIN A	1.74	2.03	
			SISO CHAIN B	1.98	2.29	
			MIMO CHAIN A	0.83	1.42	
			MIMO CHAIN B	-0.64	-0.02	
			Combined A+B	3.17	3.77	

\* Maximum values are the duty cycle compensated values calculated from the average (measured) values

**Maximum Power Spectral Density (PSD) – Overlapped channels between U-NII-2C and U-NII-3**

Mode	Rate	Channel	Freq. [MHz]	Antenna	Average conducted PSD UNII-2C [dBm/MHz]	Maximum* conducted PSD UNII-2C [dBm/MHz]
802.11n20	HT0	144	5720	SISO CHAIN A	9.21	9.28
				SISO CHAIN B	9.21	9.29
	HT8			MIMO CHAIN A	7.76	7.93
				MIMO CHAIN B	7.42	7.59
	Combined A+B			10.60	10.78	
802.11n40	HT0	142F	5710	SISO CHAIN A	5.81	5.96
				SISO CHAIN B	6.01	6.15
	HT8			MIMO CHAIN A	5.63	5.98
				MIMO CHAIN B	5.34	5.70
	Combined A+B			8.50	8.85	
802.11ac80	VHT0	138ac80	5690	SISO CHAIN A	2.78	3.07
				SISO CHAIN B	2.80	3.11
				MIMO CHAIN A	2.61	3.20
				MIMO CHAIN B	2.55	3.17
				Combined A+B	5.59	6.20

\* Maximum values are the duty cycle compensated values calculated from the average (measured) values

**Results screenshot:****802.11a, 6Mbps**





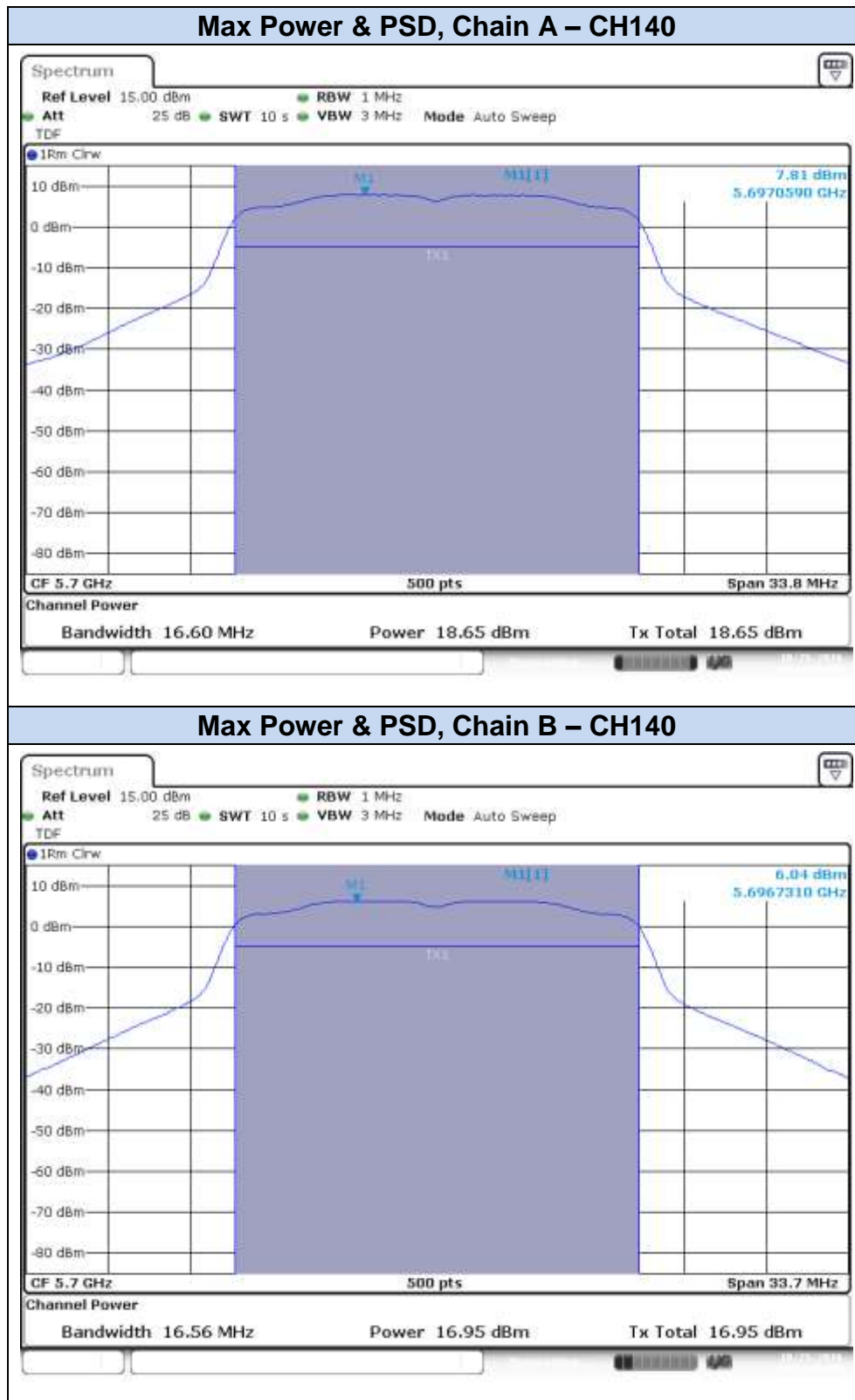

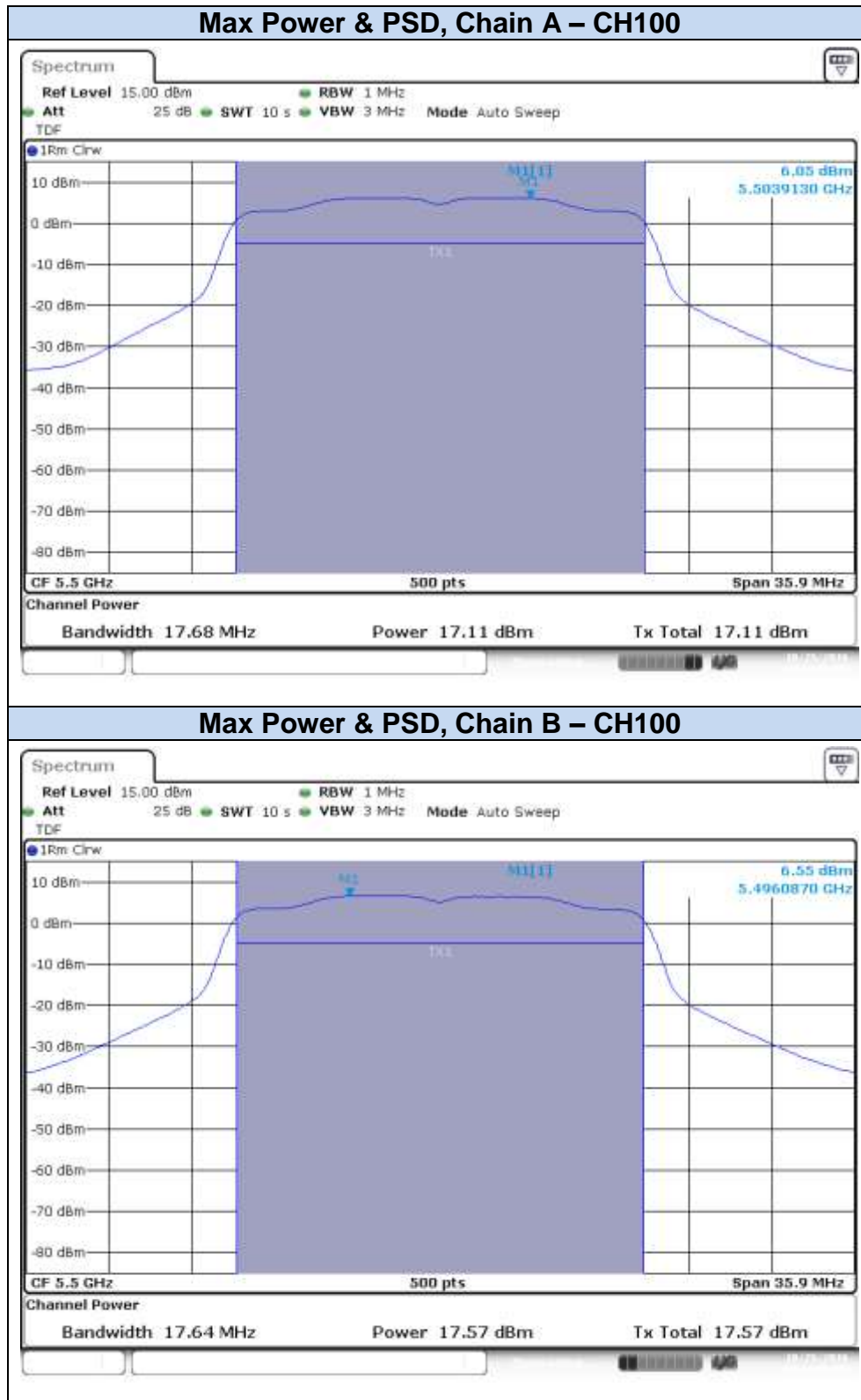
**802.11n20, HT0 (SISO)**

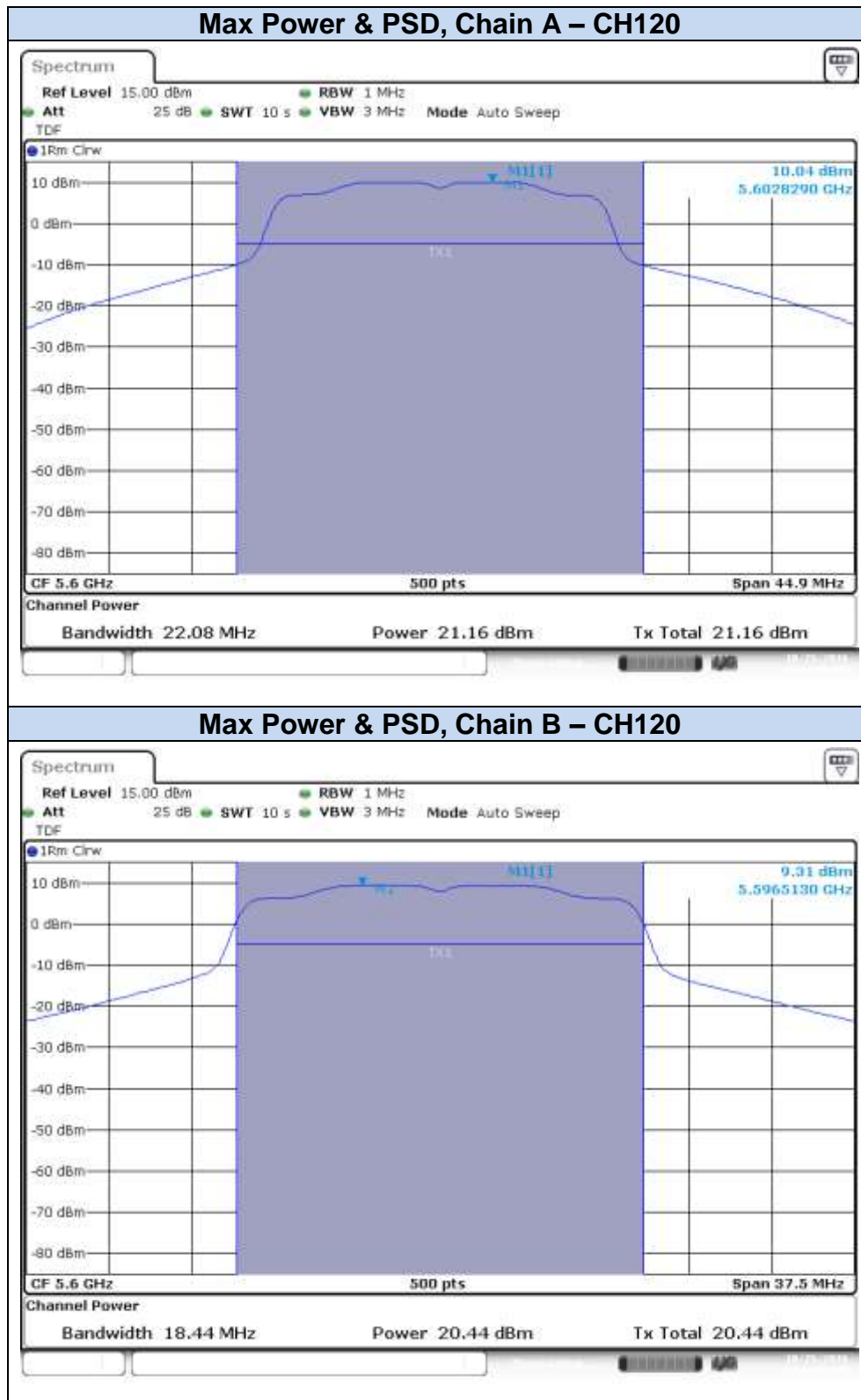



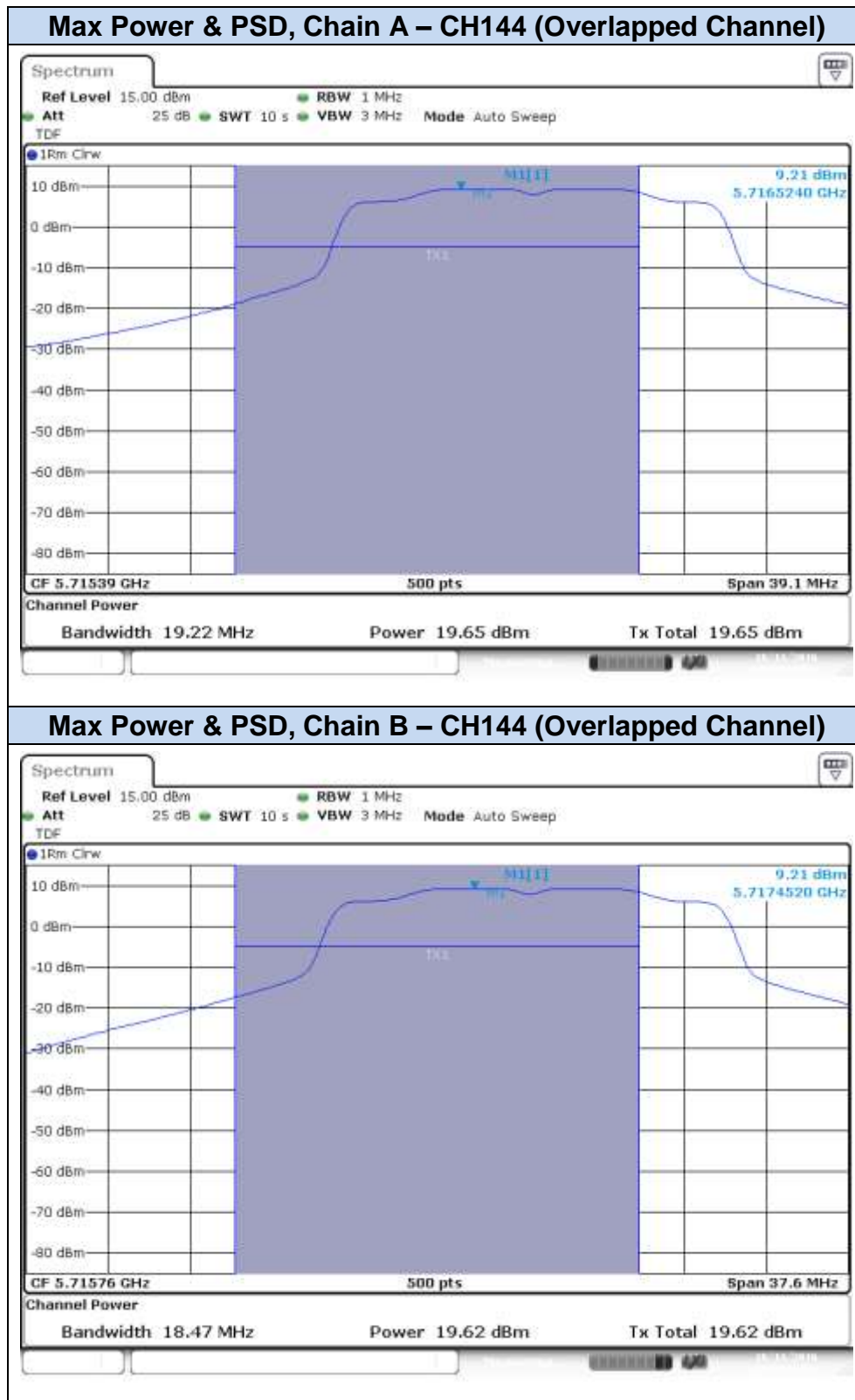

### 802.11n20, HT8 (MIMO)

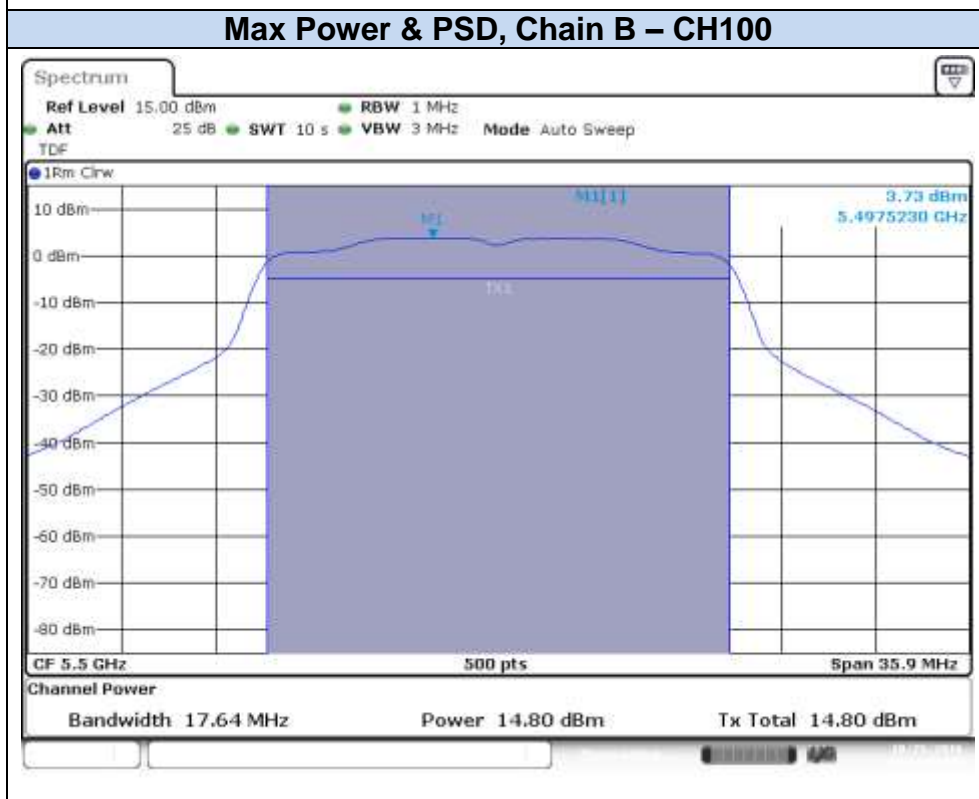
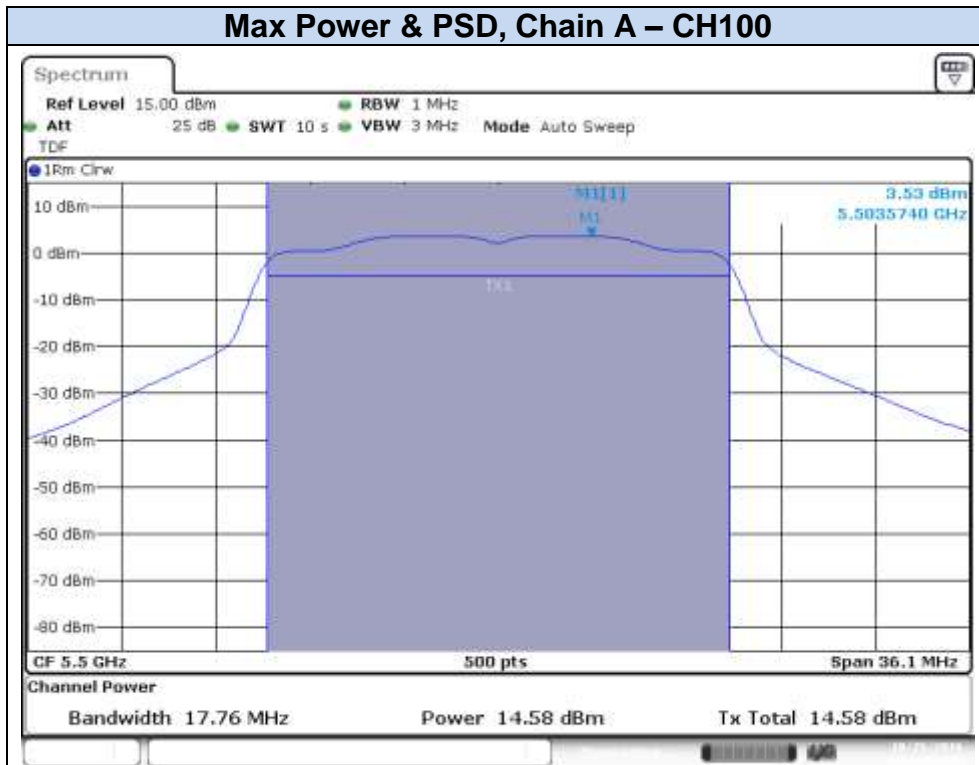

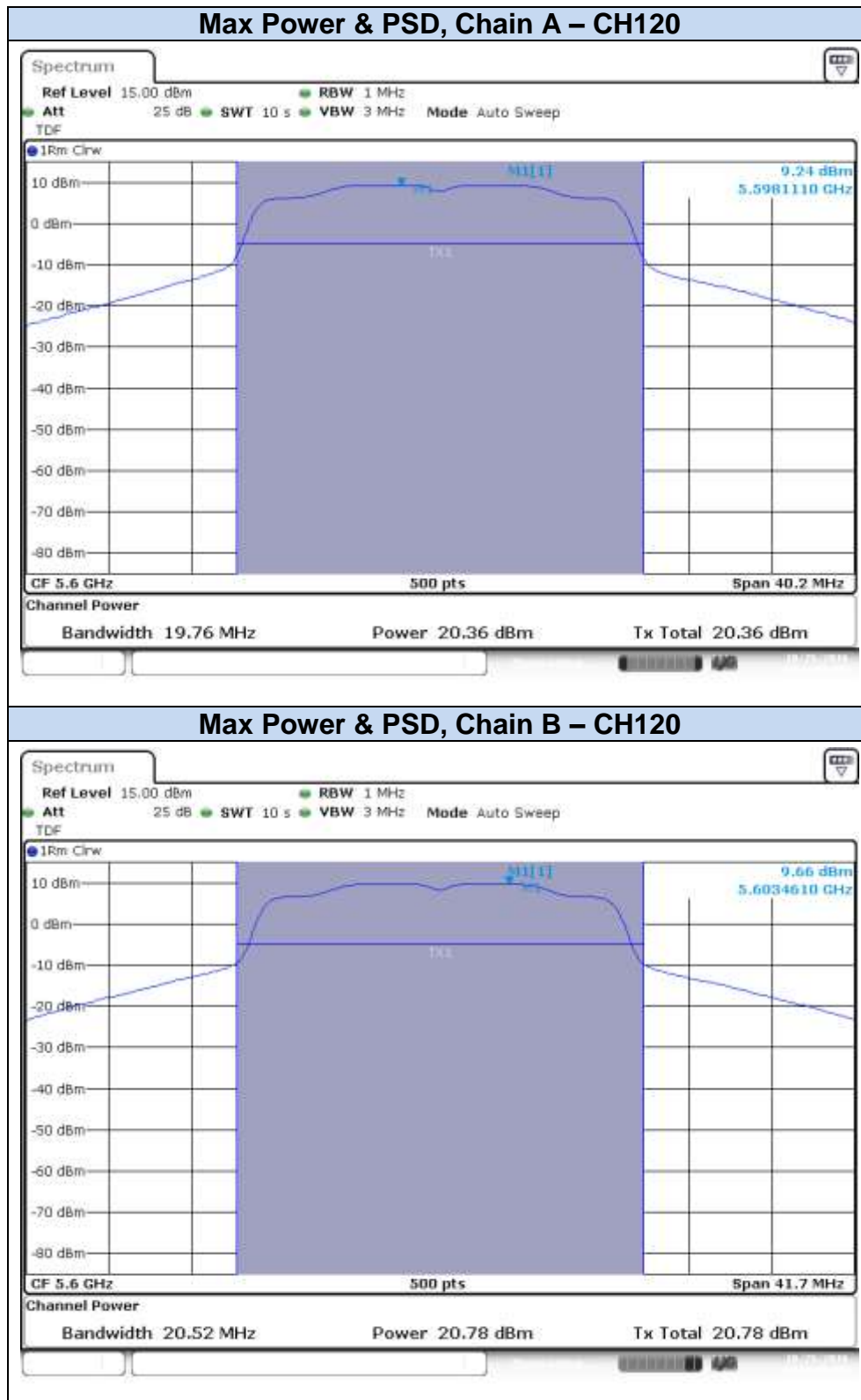



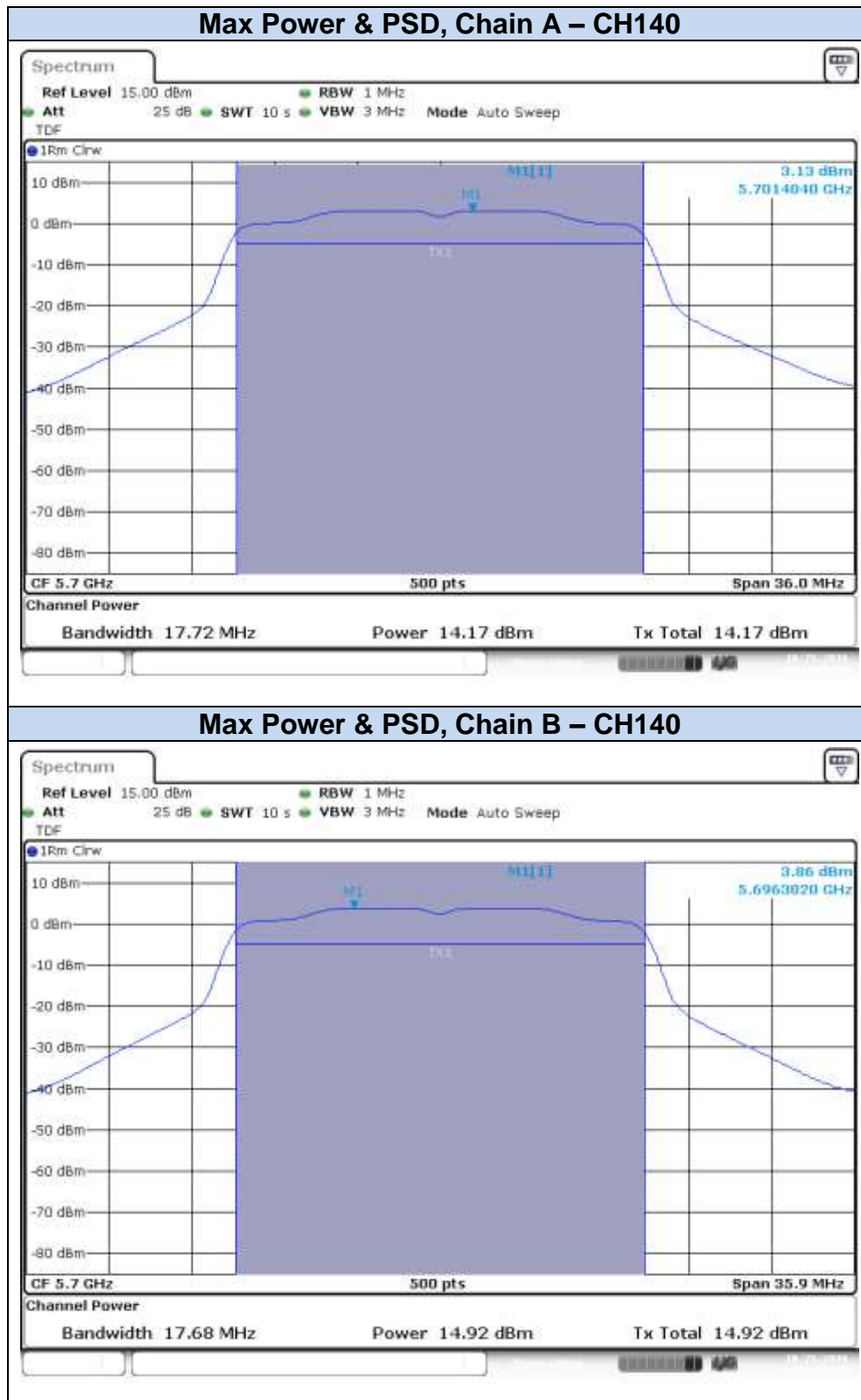



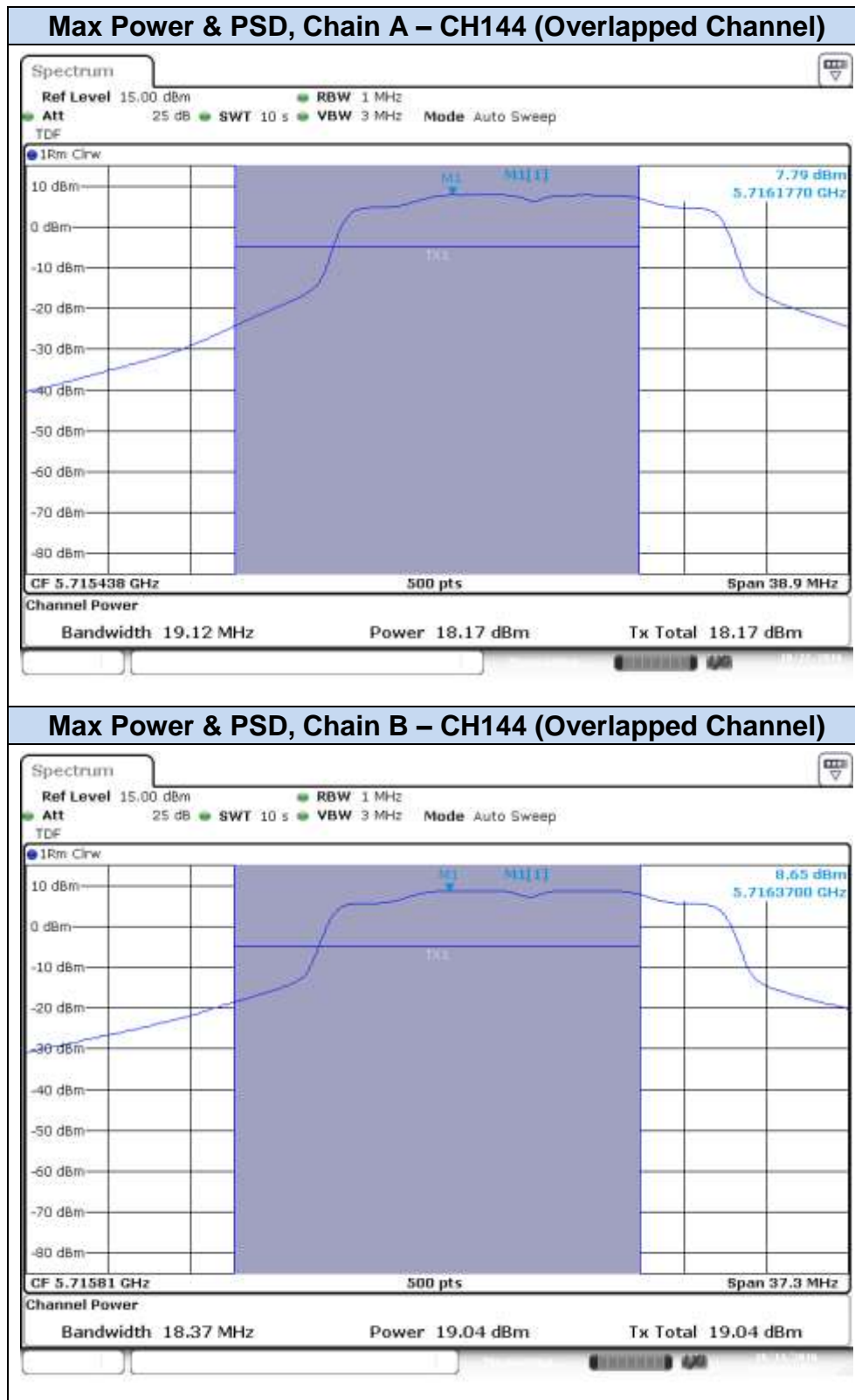

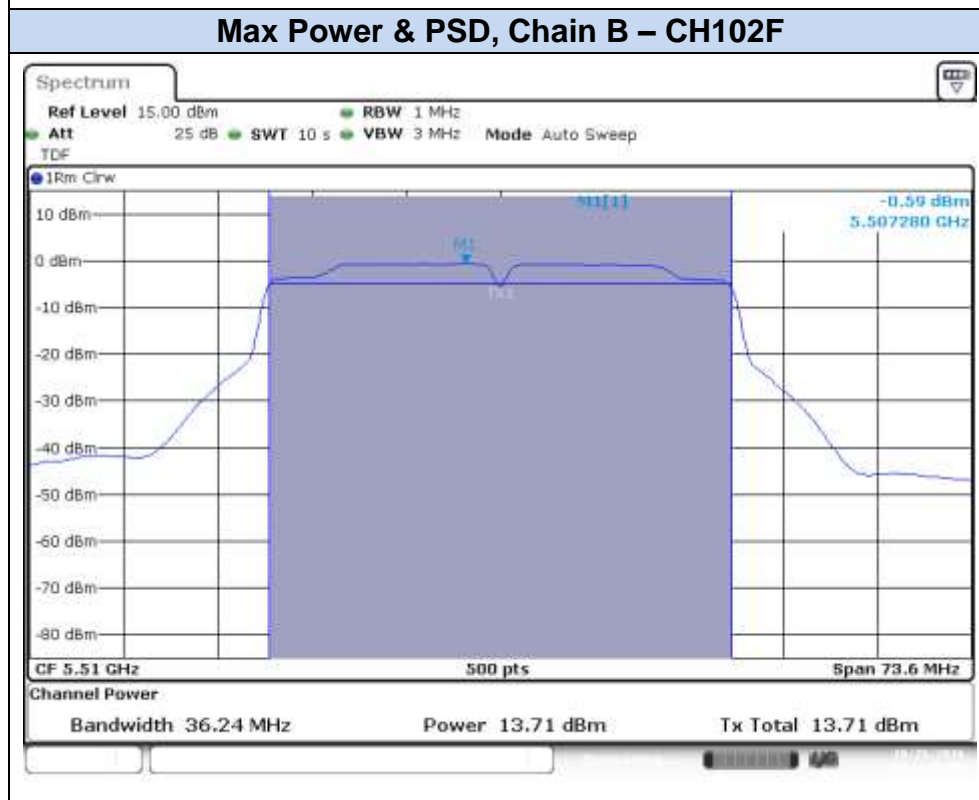
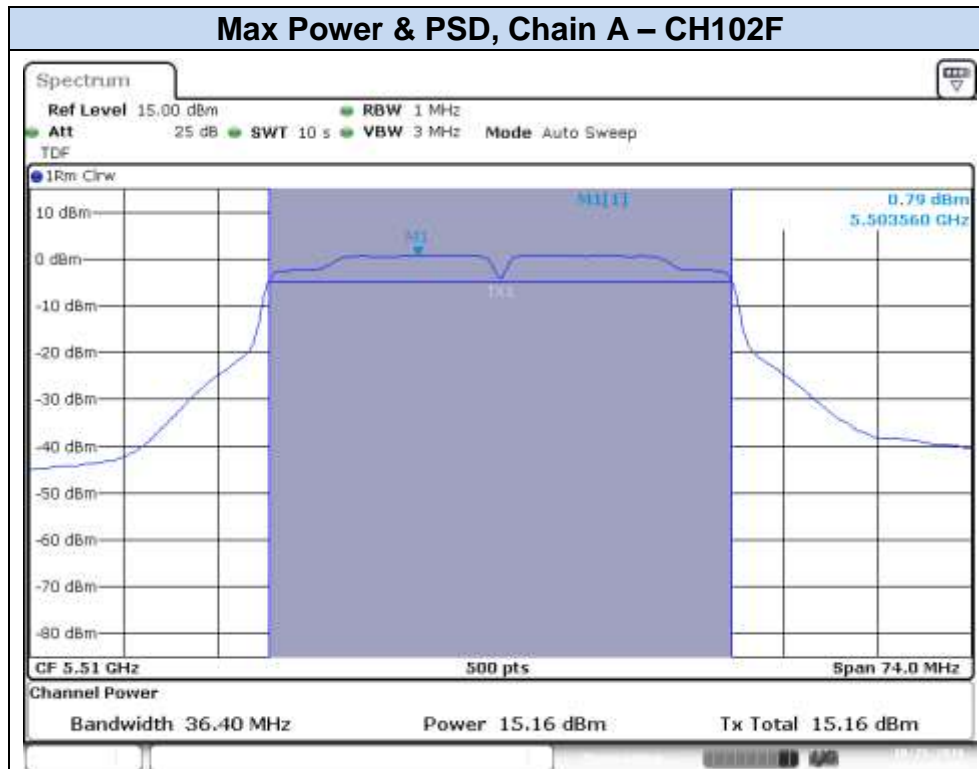
**802.11n40, HT0 (SISO)**

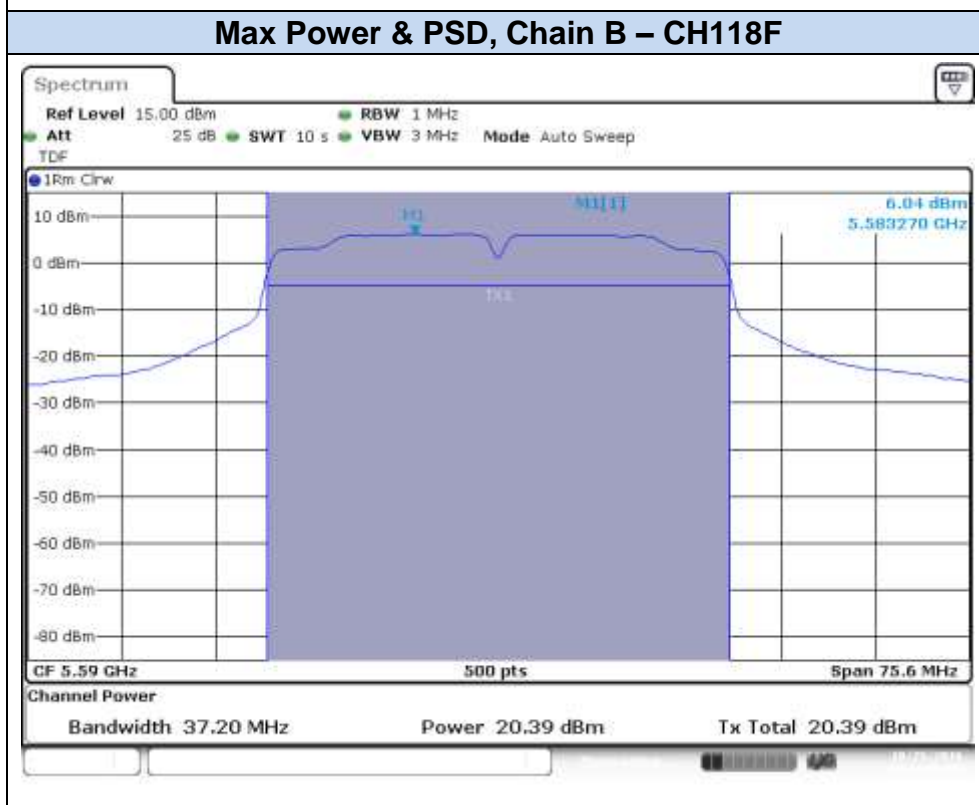
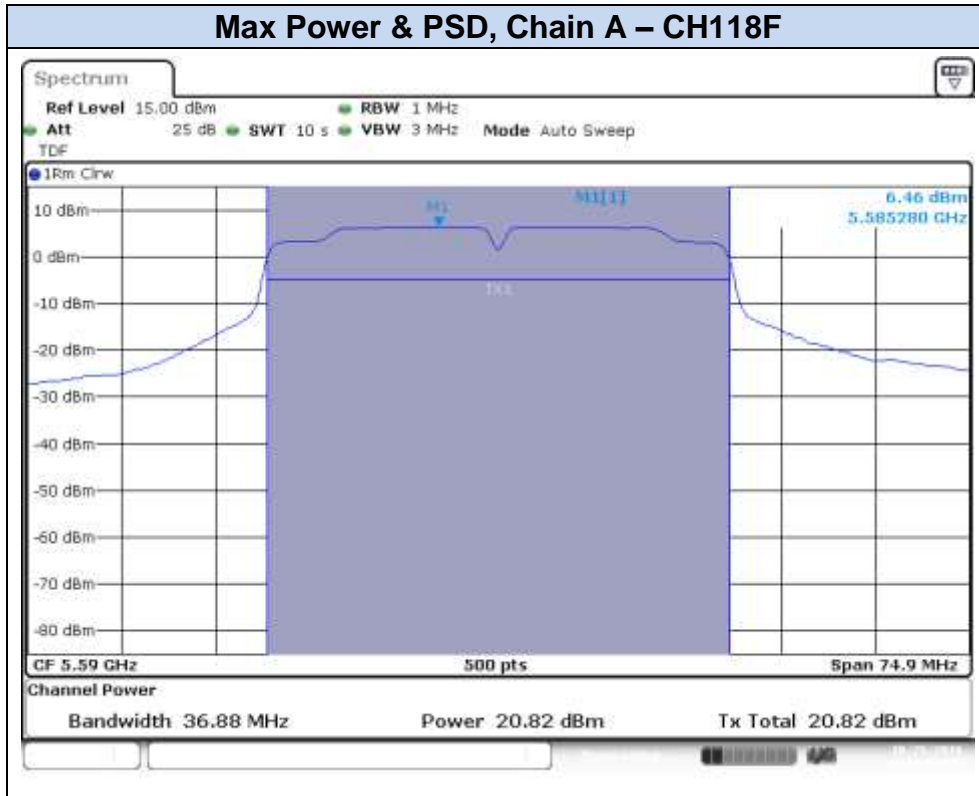

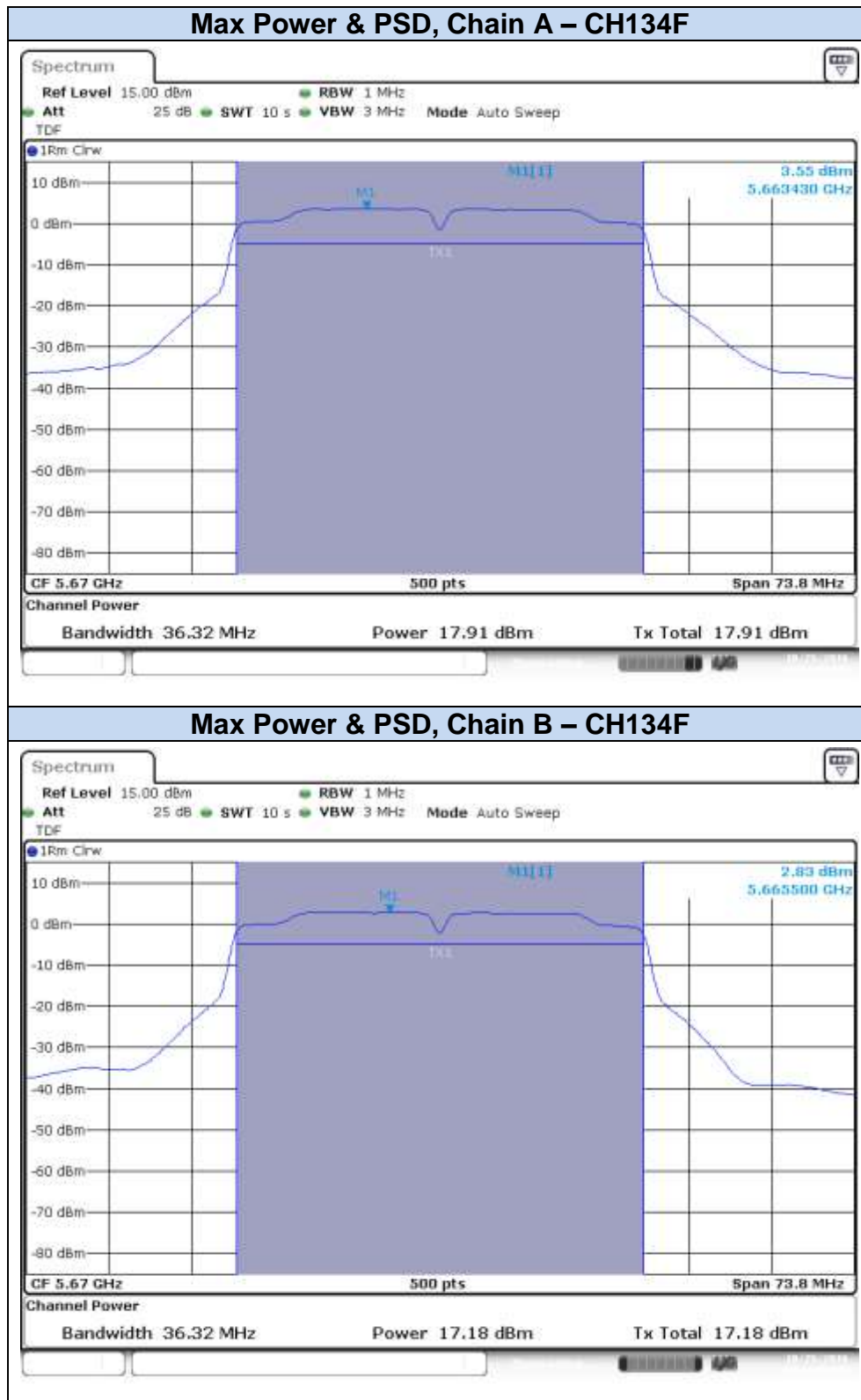

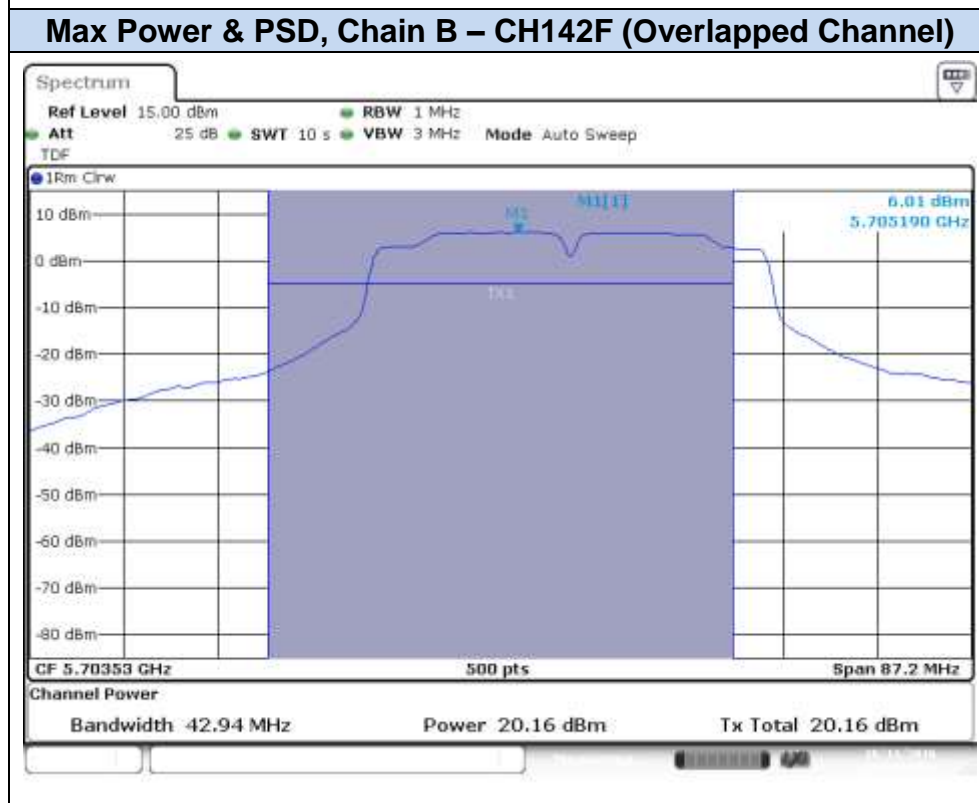
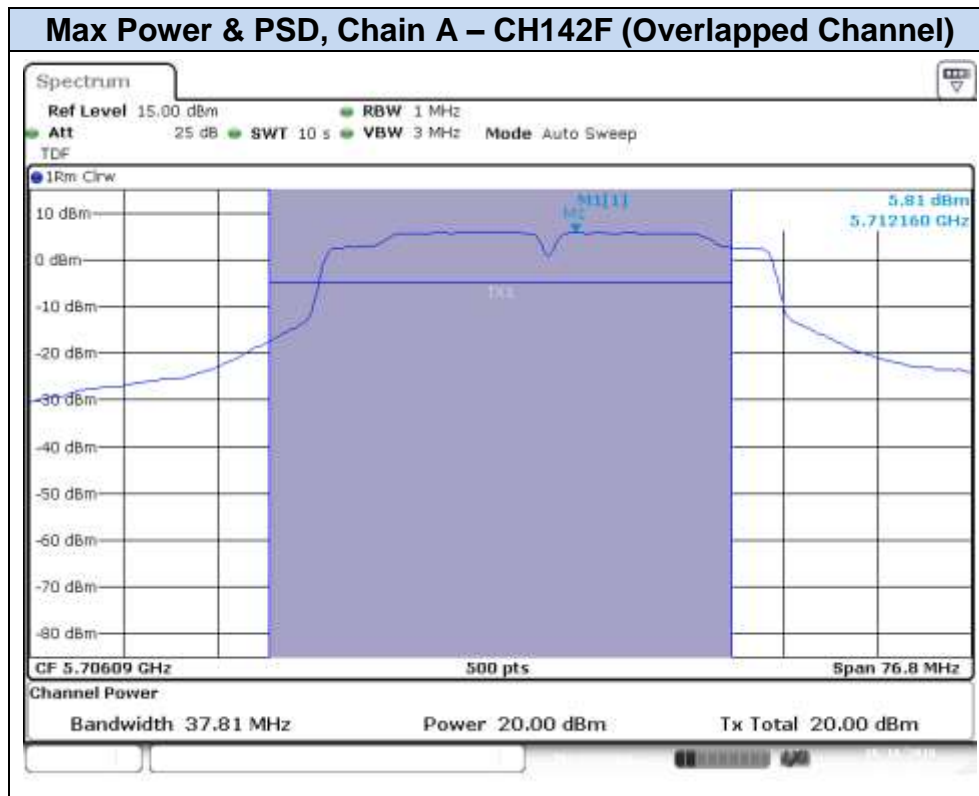

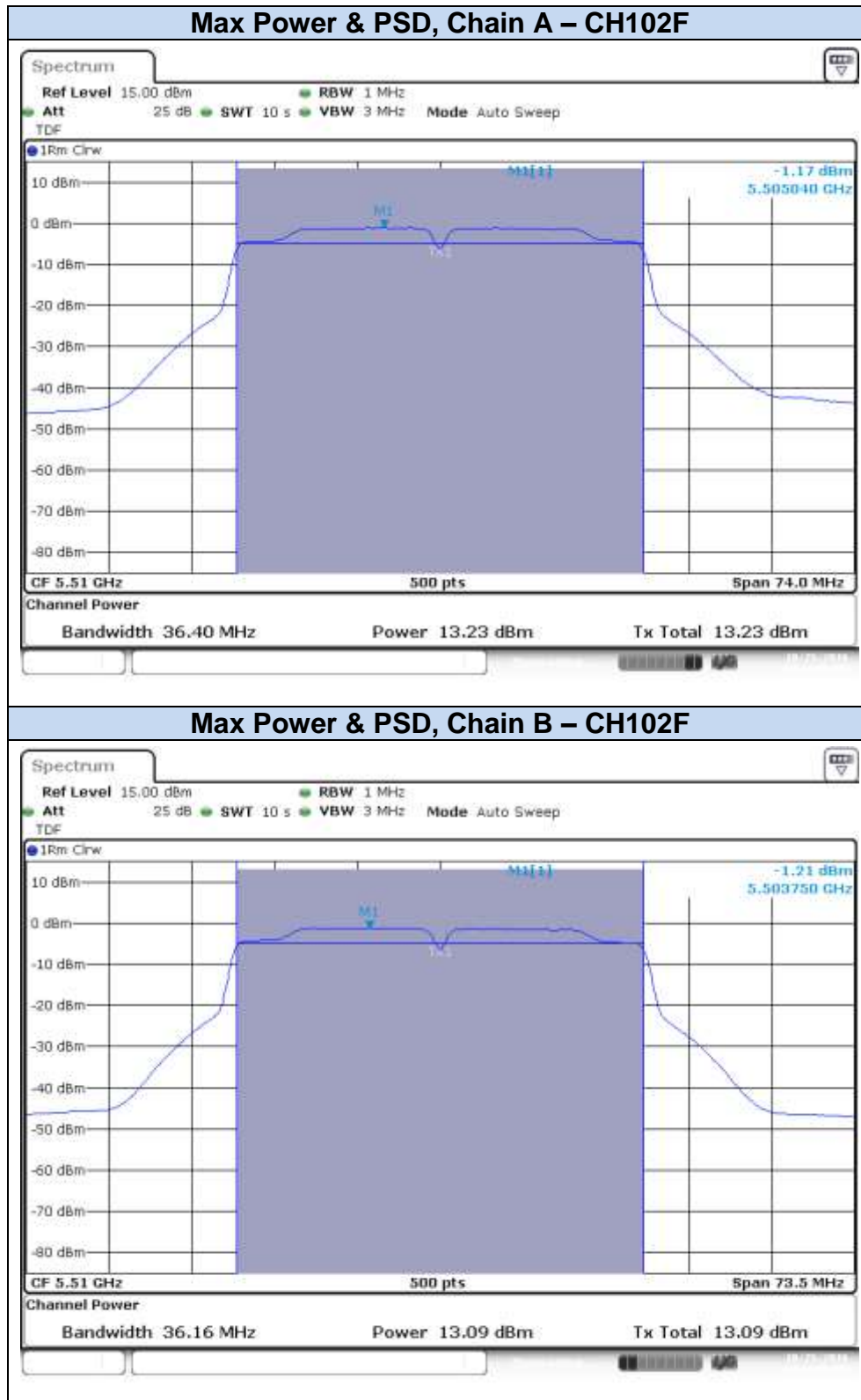
**802.11n40, HT8 (MIMO)**

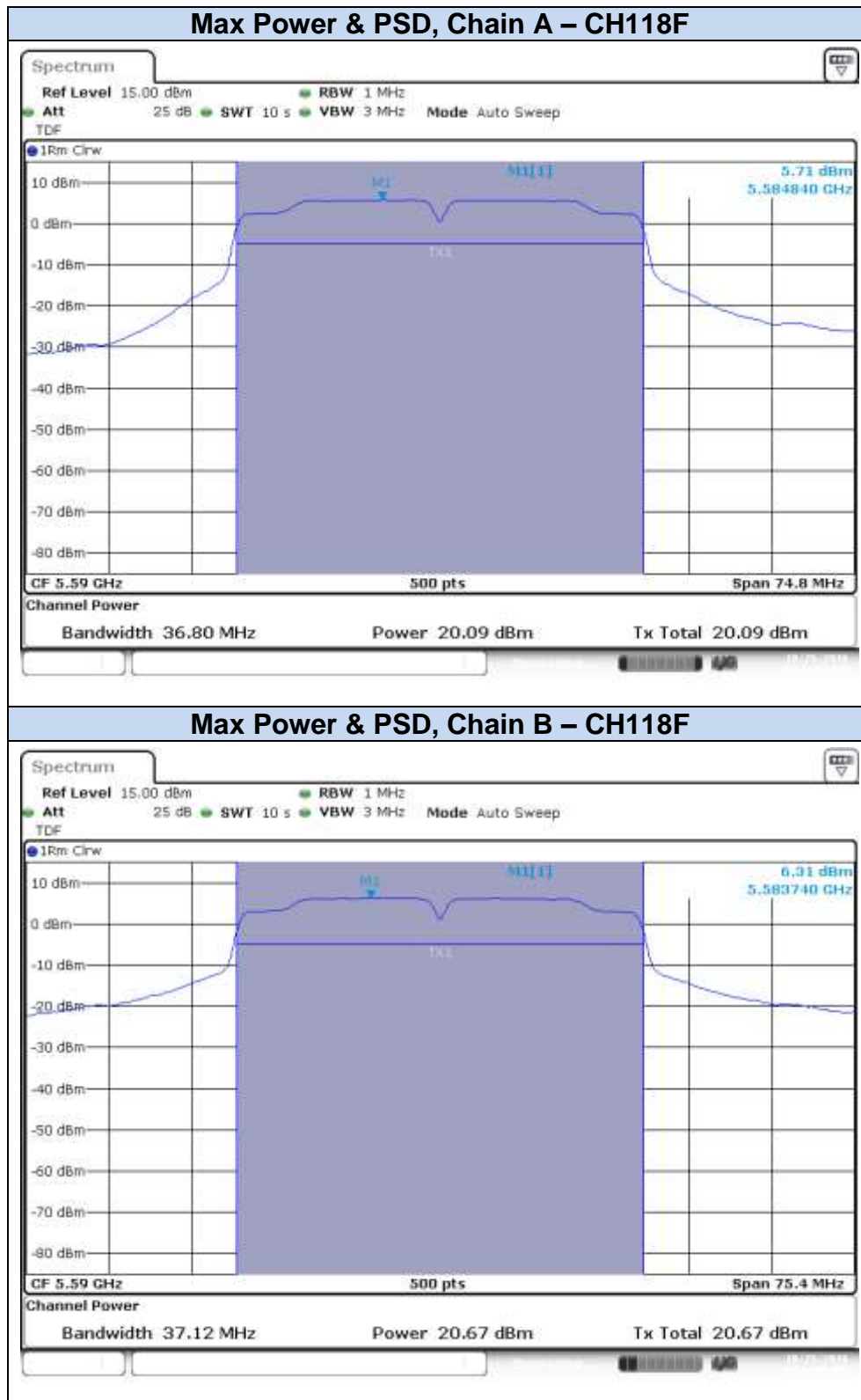



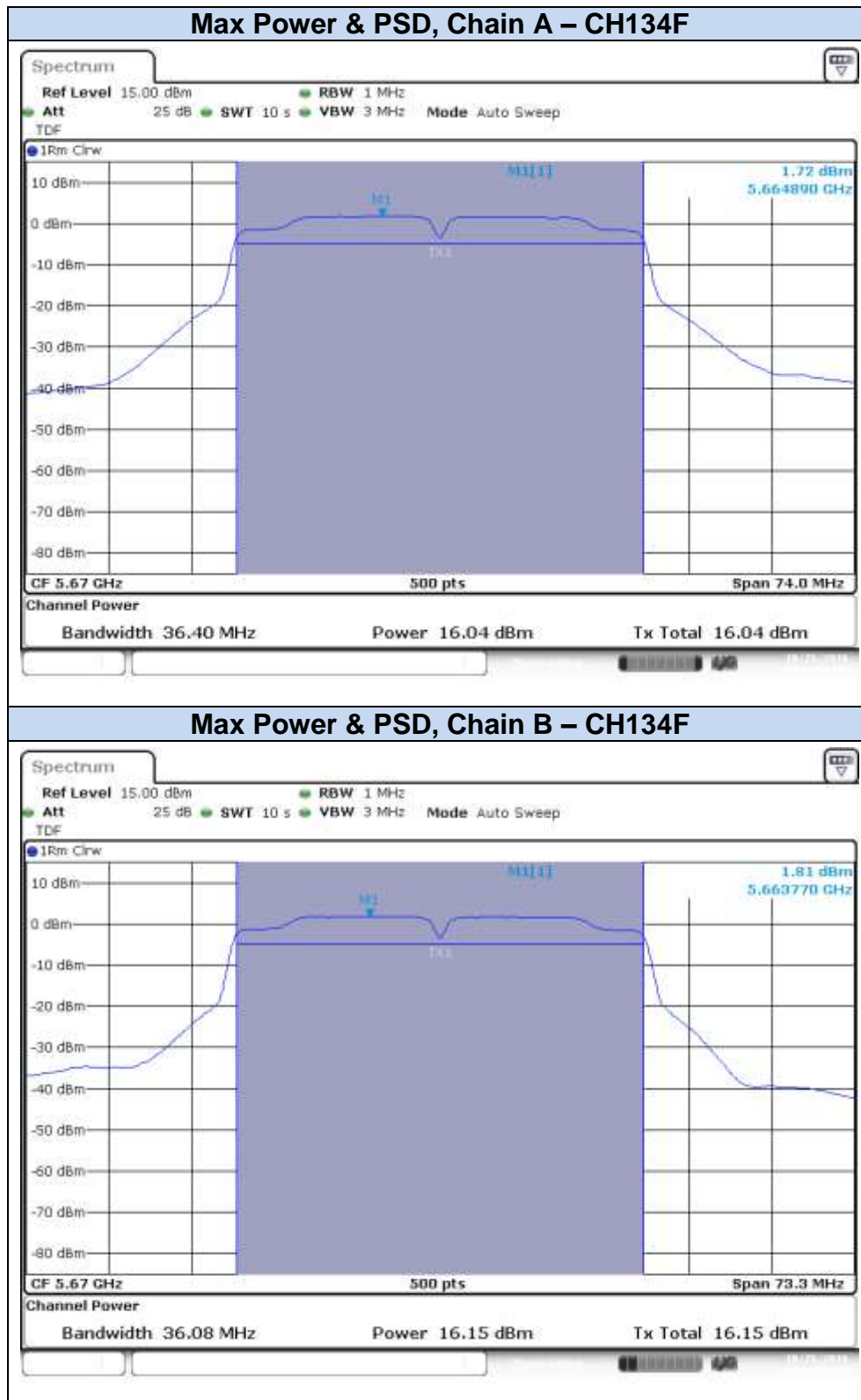



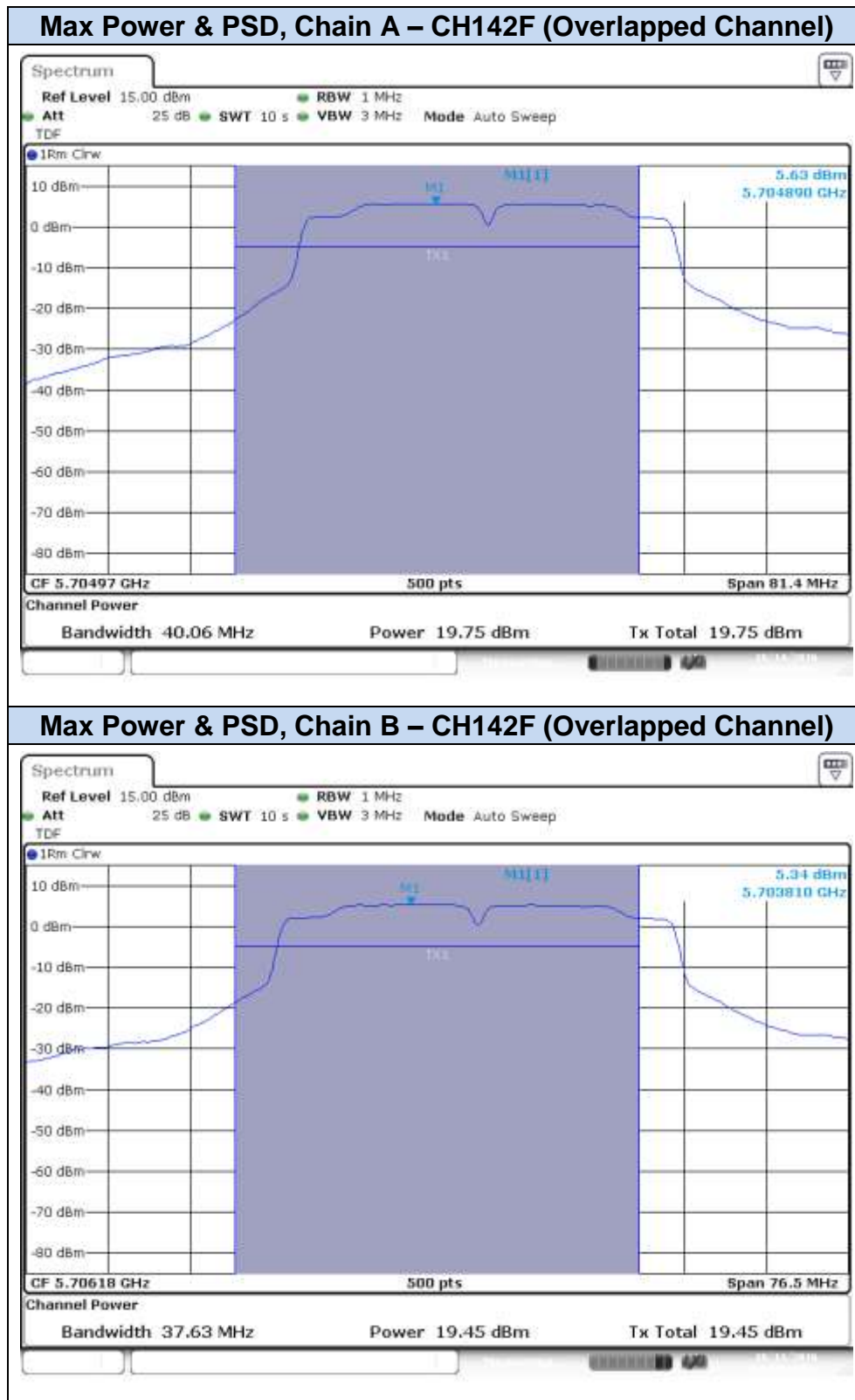

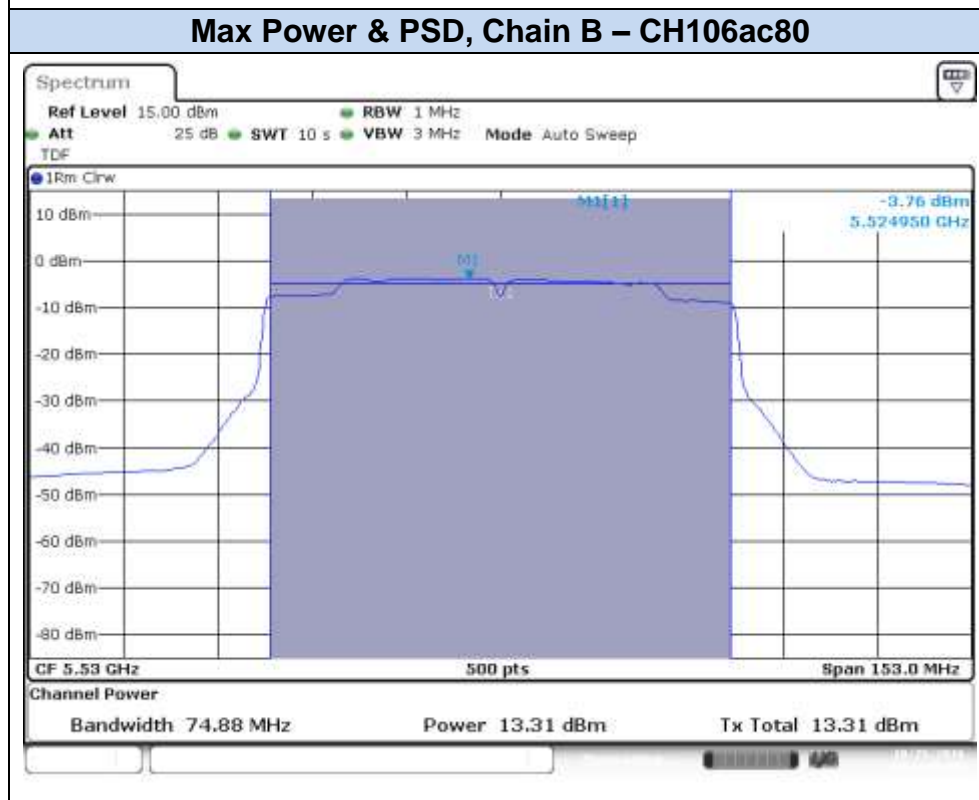
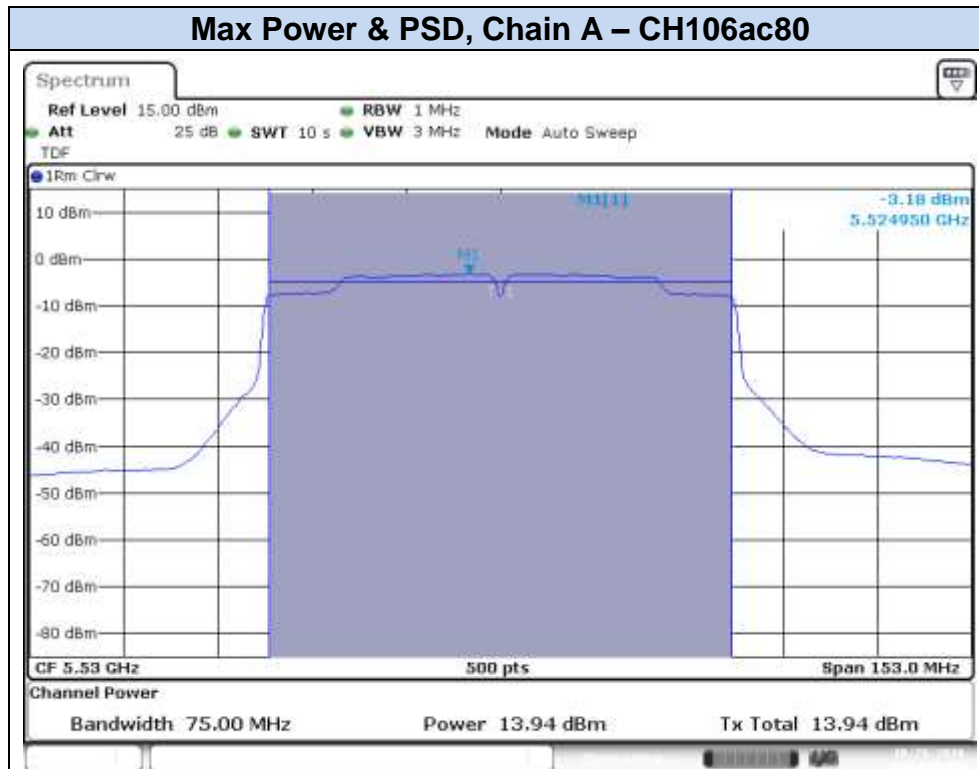
**802.11ac80, VHT0 (SISO)**

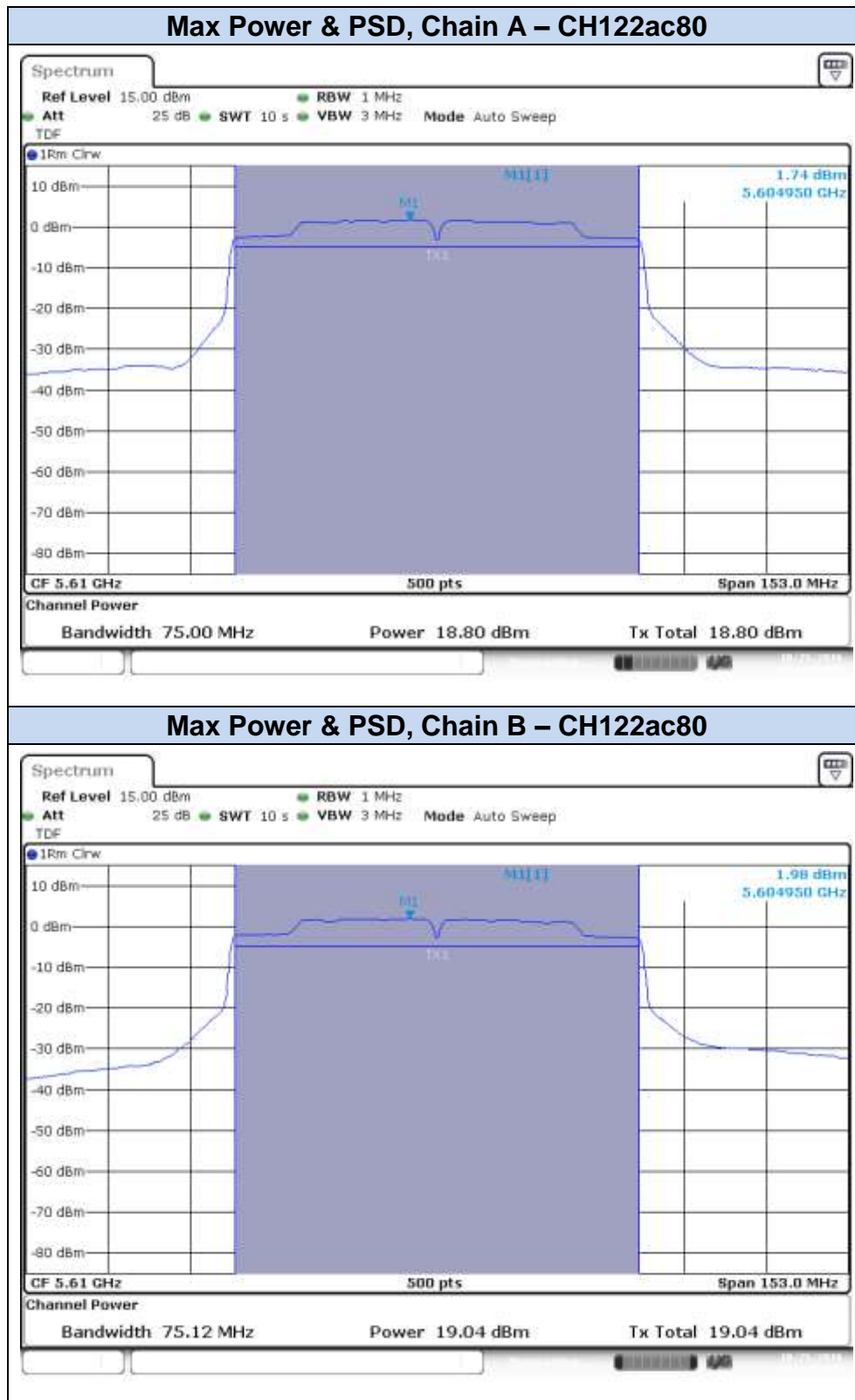

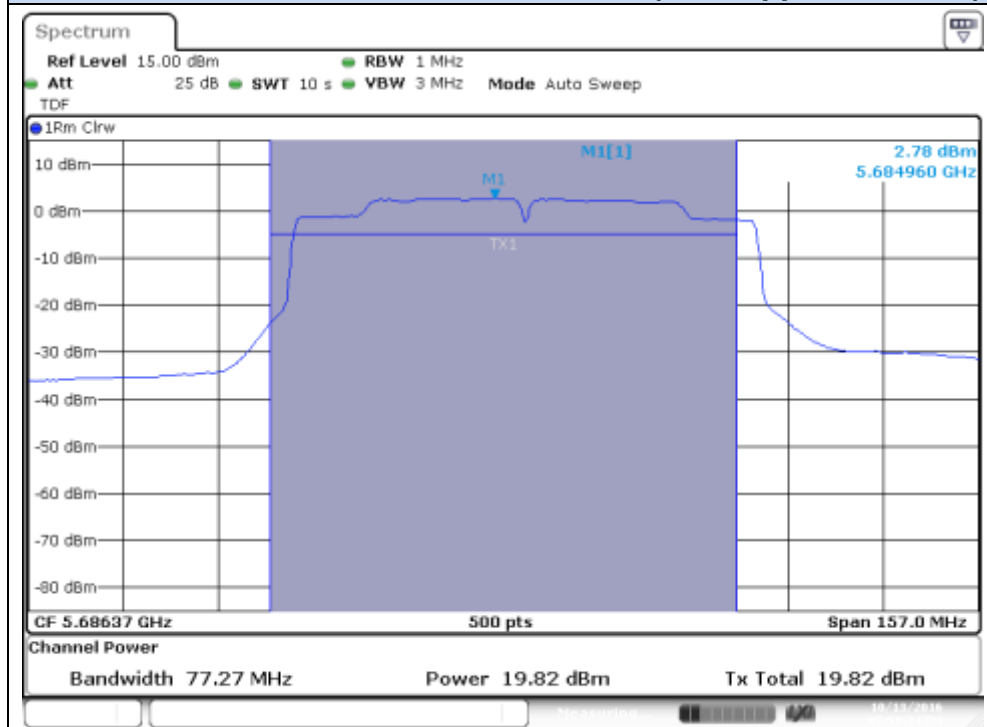
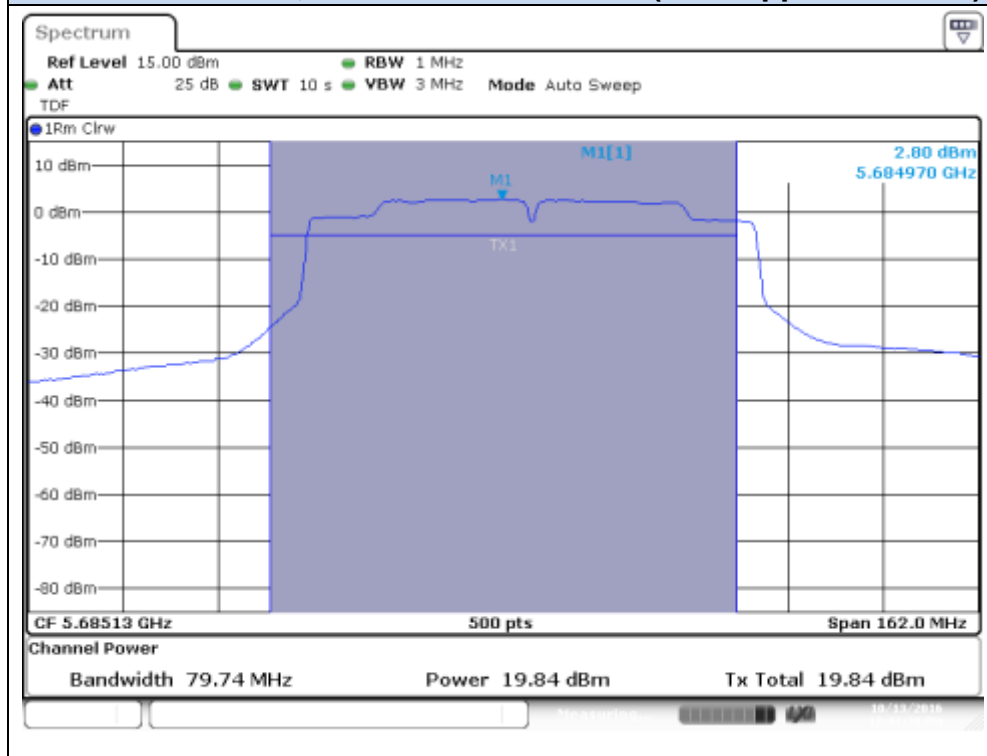
**Max Power & PSD, Chain A – CH138ac80 (Overlapped Channel)****Max Power & PSD, Chain B – CH138ac80 (Overlapped Channel)**

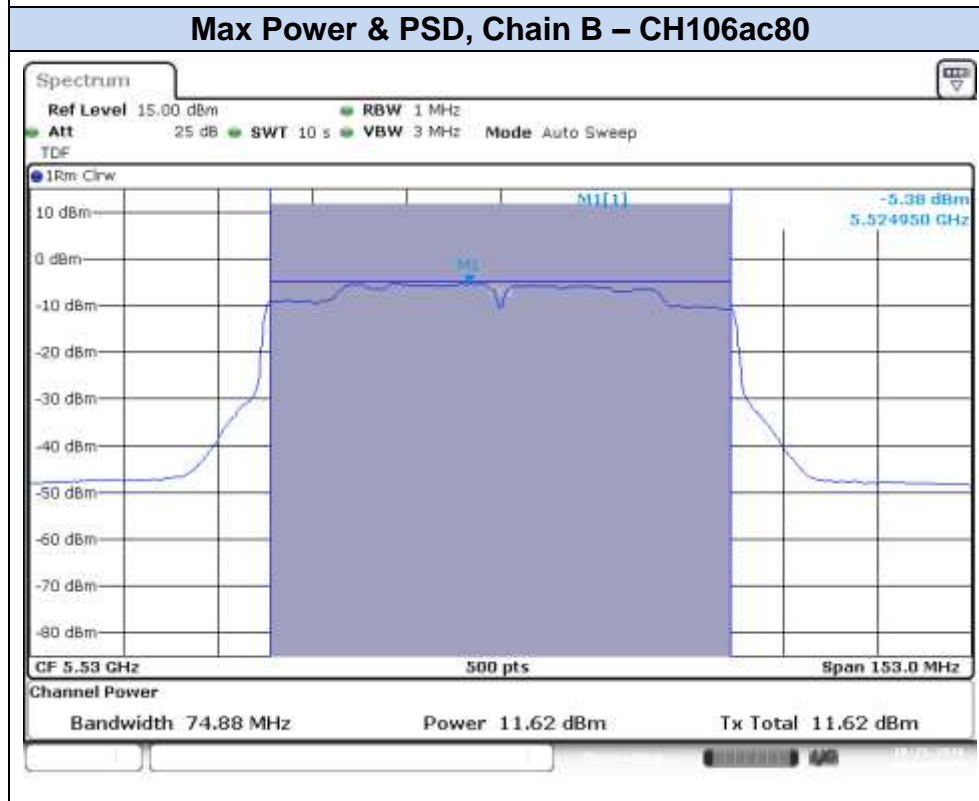
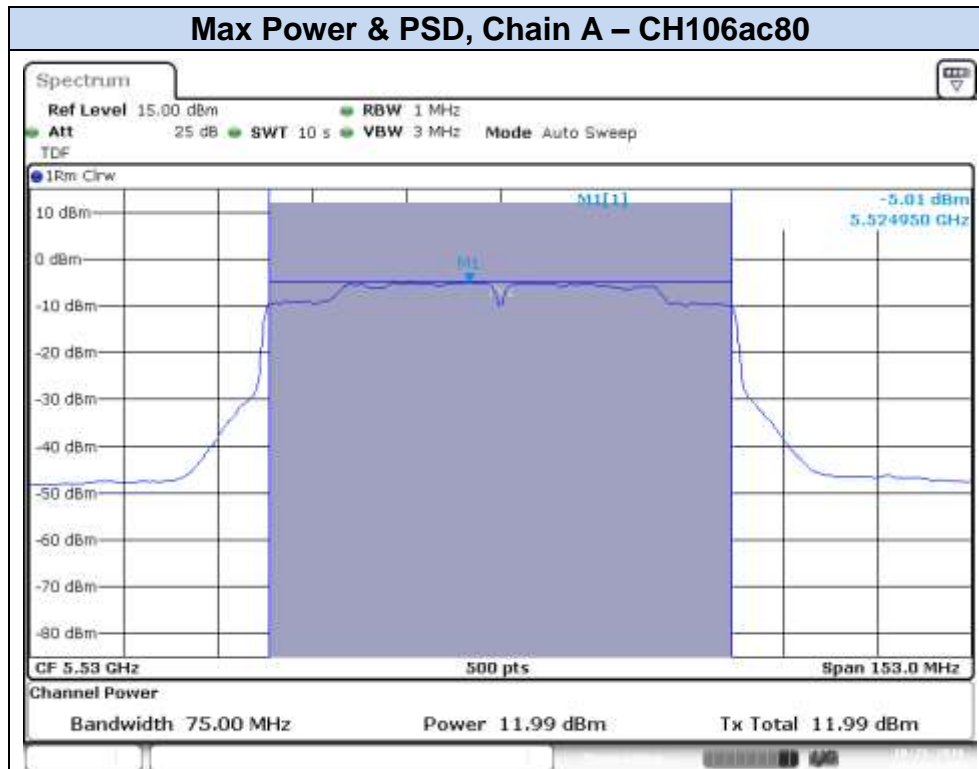
**802.11ac80, VHT0 (MIMO)**

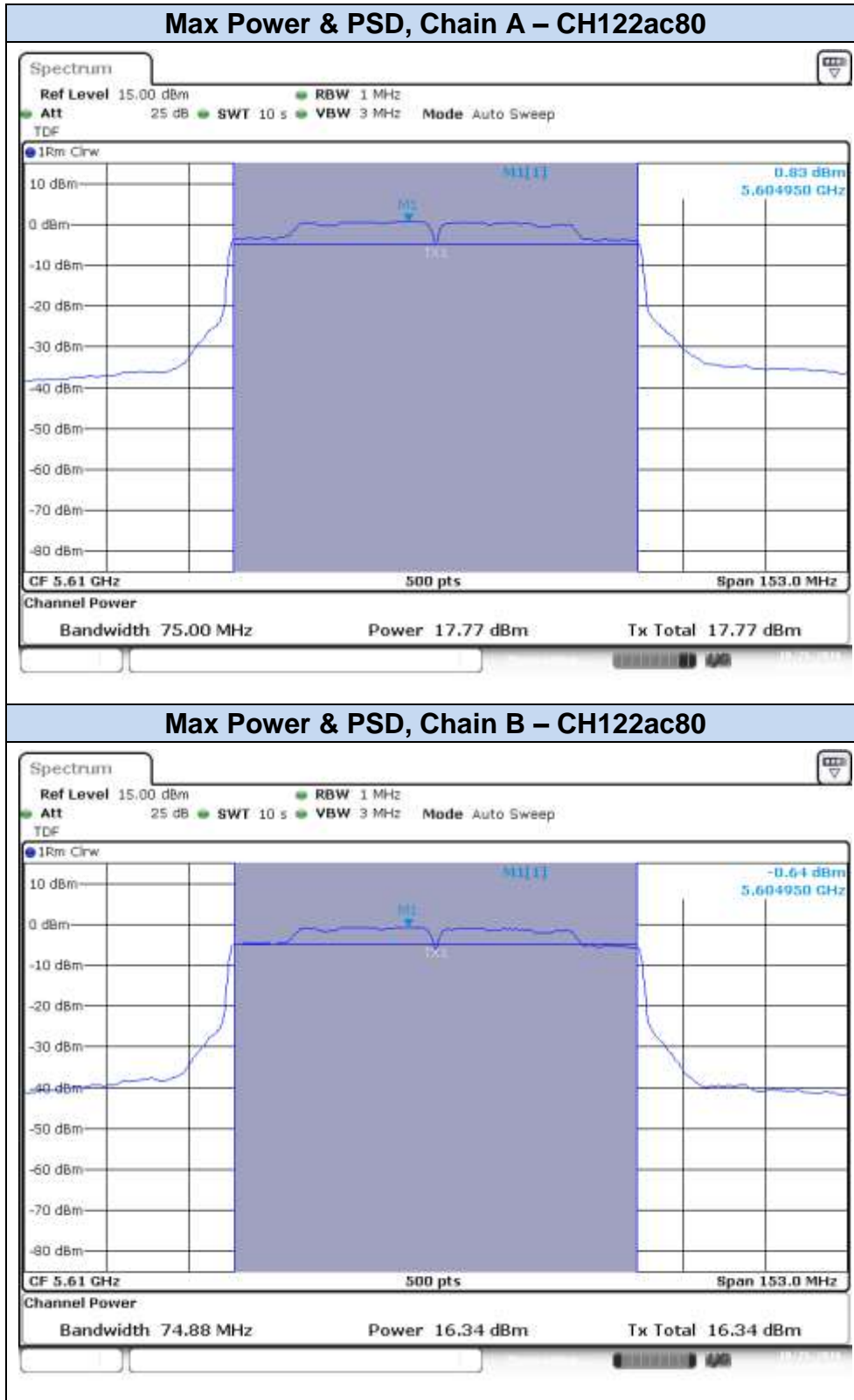

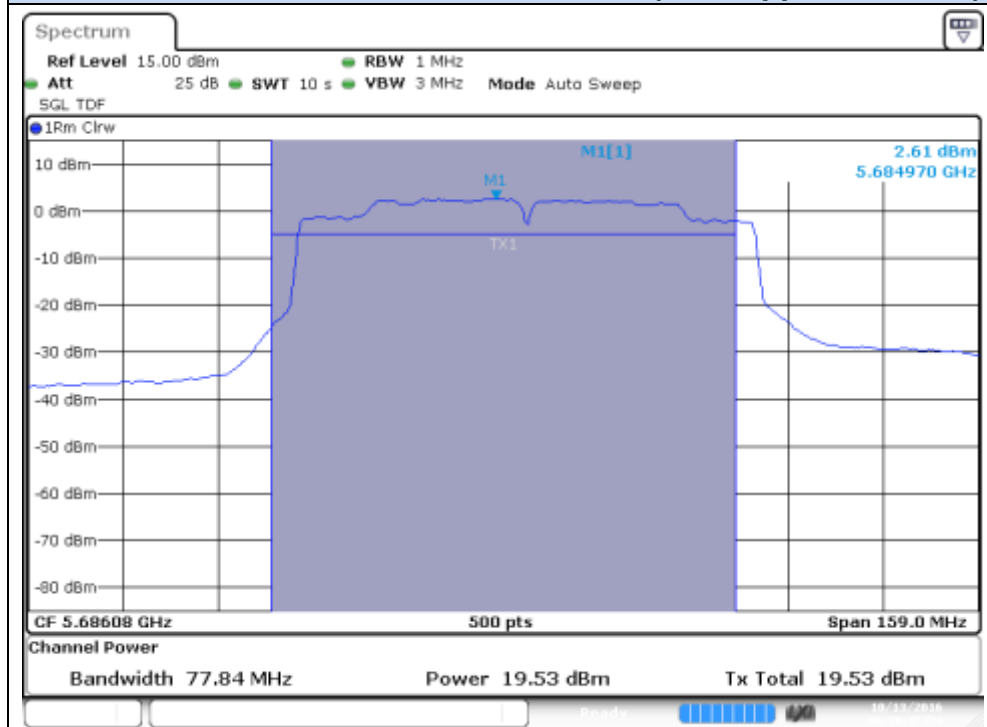
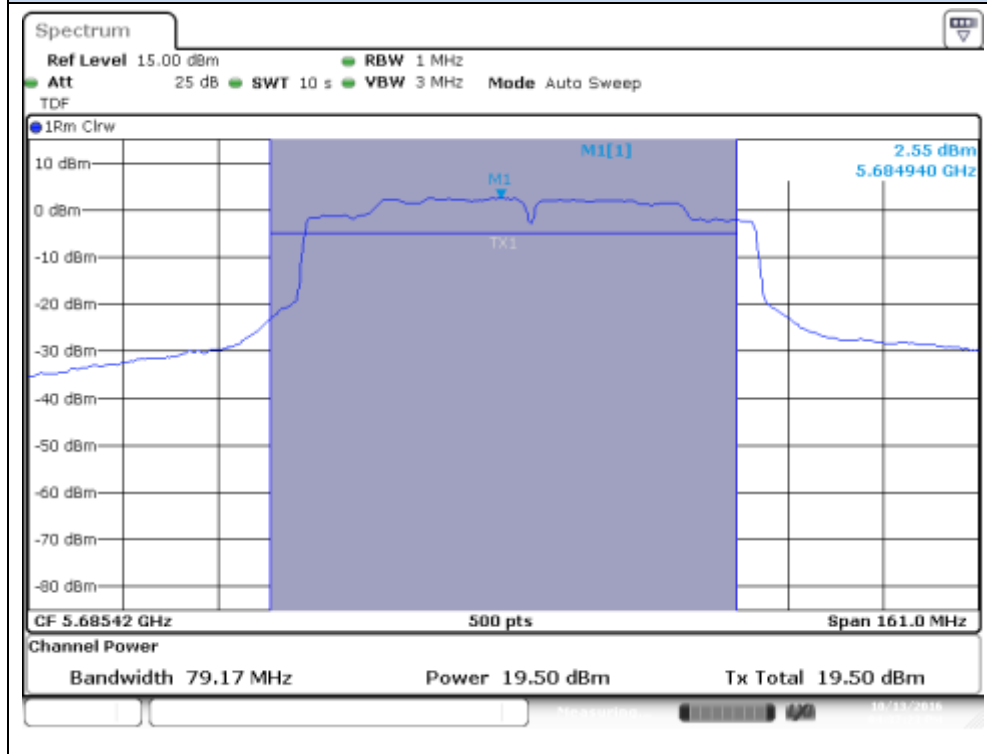
**Max Power & PSD, Chain A – CH138ac80 (Overlapped Channel)****Max Power & PSD, Chain B – CH138ac80 (Overlapped Channel)**

### B.3 Undesirable emissions limits: Band Edge (conducted)

**Test limits:**

FCC part	RSS part	Limits																																
15.407 (b) (3)	RSS-247 Clause 6.2.2 (2)	For transmitters operating in the 5.47–5.725 GHz band: all emissions outside of the 5.47–5.725 GHz band shall not exceed an EIRP of -27 dBm/MHz.																																
15.209	RSS-GEN, Clause 8.9	<p>Radiated emissions which fall in the restricted bands, as defined in §15.205(a), must also comply with the radiated emission limits specified in §15.209(a):</p> <table border="1"> <thead> <tr> <th>Freq Range (MHz)</th> <th>Field Strength (μV/m)</th> <th>Field Strength (dBμV/m)</th> <th>Meas. Distance (m)</th> </tr> </thead> <tbody> <tr> <td>0.009-0.490</td> <td>2400/f(kHz)</td> <td>-</td> <td>300</td> </tr> <tr> <td>0.490-1.705</td> <td>24000/f(kHz)</td> <td>-</td> <td>300</td> </tr> <tr> <td>1.705-30.0</td> <td>30</td> <td>-</td> <td>30</td> </tr> <tr> <td>30-88</td> <td>100</td> <td>40</td> <td>3</td> </tr> <tr> <td>88-216</td> <td>150</td> <td>43.5</td> <td>3</td> </tr> <tr> <td>216-960</td> <td>200</td> <td>46</td> <td>3</td> </tr> <tr> <td>960-25000</td> <td>500</td> <td>54</td> <td>3</td> </tr> </tbody> </table> <p>The emission limits shown in the table above are based on measurements employing CISPR quasi-peak detector except for the frequency bands 9-90 kHz, 110-490 kHz and above 1000 MHz. Radiated emission limits in these three bands are based on measurements employing an average detector.</p> <p>For average radiated emission measurements above 1000 MHz, there is also a limit specified when measuring with peak detector function, corresponding to 20 dB above the indicated values in the table.</p>	Freq Range (MHz)	Field Strength (μV/m)	Field Strength (dBμV/m)	Meas. Distance (m)	0.009-0.490	2400/f(kHz)	-	300	0.490-1.705	24000/f(kHz)	-	300	1.705-30.0	30	-	30	30-88	100	40	3	88-216	150	43.5	3	216-960	200	46	3	960-25000	500	54	3
Freq Range (MHz)	Field Strength (μV/m)	Field Strength (dBμV/m)	Meas. Distance (m)																															
0.009-0.490	2400/f(kHz)	-	300																															
0.490-1.705	24000/f(kHz)	-	300																															
1.705-30.0	30	-	30																															
30-88	100	40	3																															
88-216	150	43.5	3																															
216-960	200	46	3																															
960-25000	500	54	3																															

**Test procedure:**

The setup below was used to measure undesirable emissions on the Band Edge domain. The antenna terminal of the EUT is connected to the spectrum analyzer through an attenuator, and the spectrum analyzer reading is compensated to include the RF path loss and the declared Antenna Gain.

For Band Edge measurements in average mode on the low frequency section, the Video Bandwidth Method was used according to section G) 6) (KDB 789033 D02), with the following parameters:

- When the duty cycle is > 98 %, VBW = 10Hz
- When the duty cycle is < 98 %, VBW > 1/T, where T is defined in section II.B.1.a

For the BE High, we use the integration method as defined in the band edge measurements section (paragraph II.G.3.d) of KDB 789033 D02.

In case of Band Edge measurements falling in restricted bands, the declared Antenna Gain is also compensated in the graph.

The declared maximum antenna gain is 5dBi.



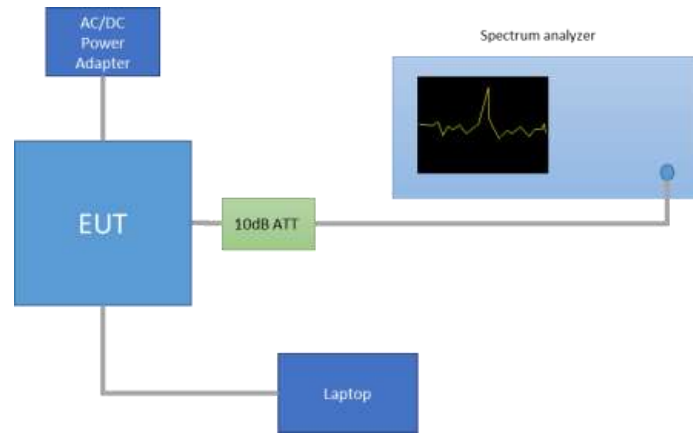

The following limits in dBm were applied for the average detector after the conversion from the limits detailed above in dB $\mu$ V/m, according to FCC 47 CFR part 15 - Subpart C – §15.209(a). The limits in dBm for peak detector are 20dB above the indicated values in the table.

§15.209(a)			Converted values	
Freq Range (MHz)	Distance (m)	Field strength (microvolts/meter)	Field strength (dB microvolts/meter)	Power (dBm)
960-25000	3	500	53.98	-41.25

**Results Screenshot:**

**802.11a, 6Mbps – Chain A**

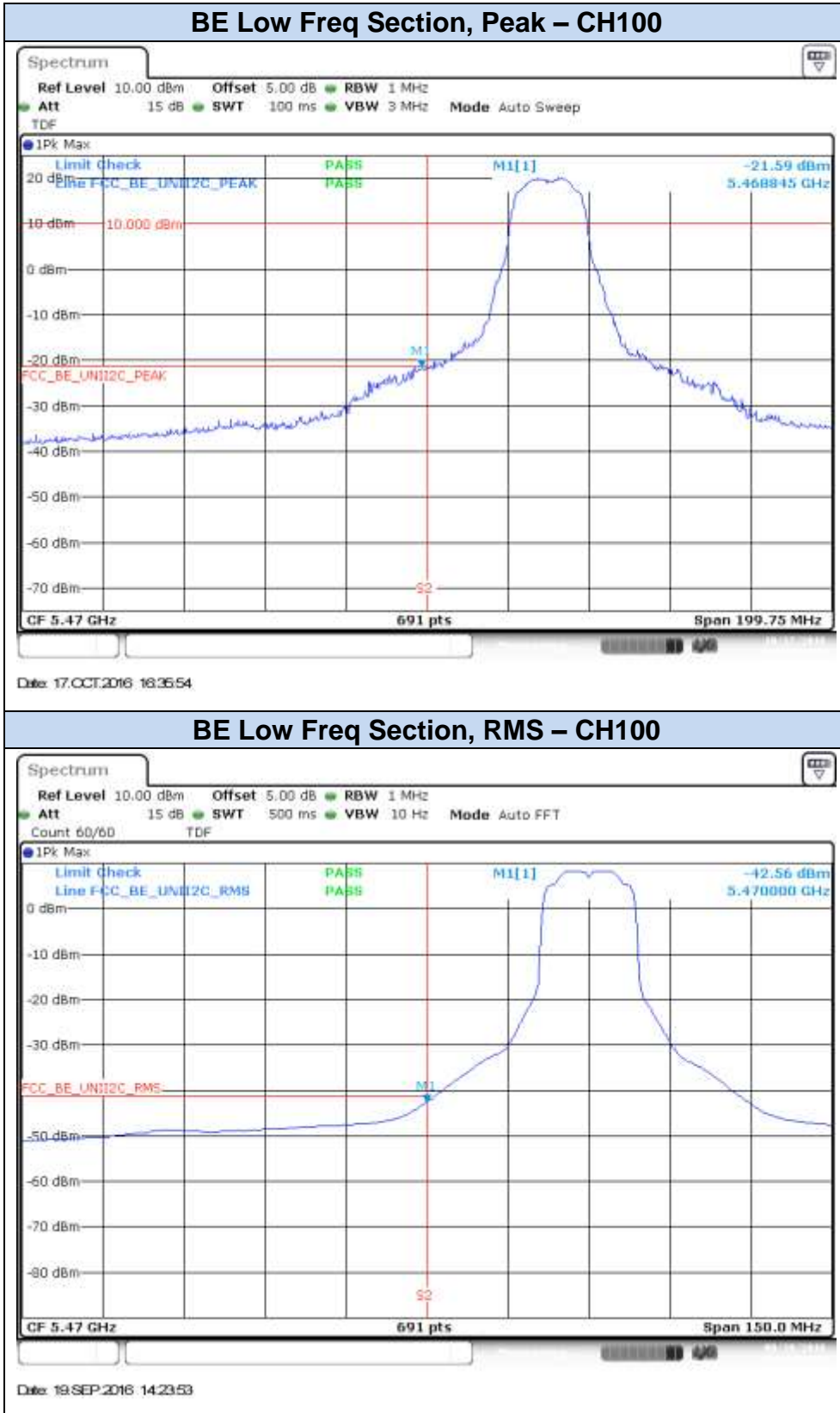

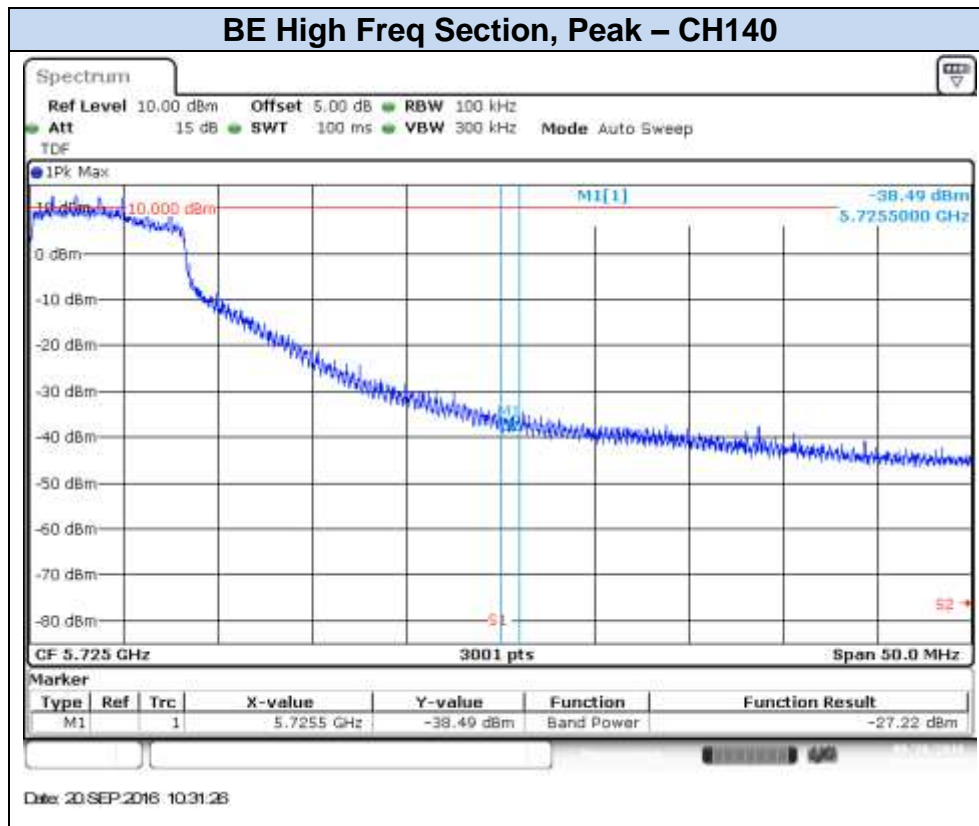

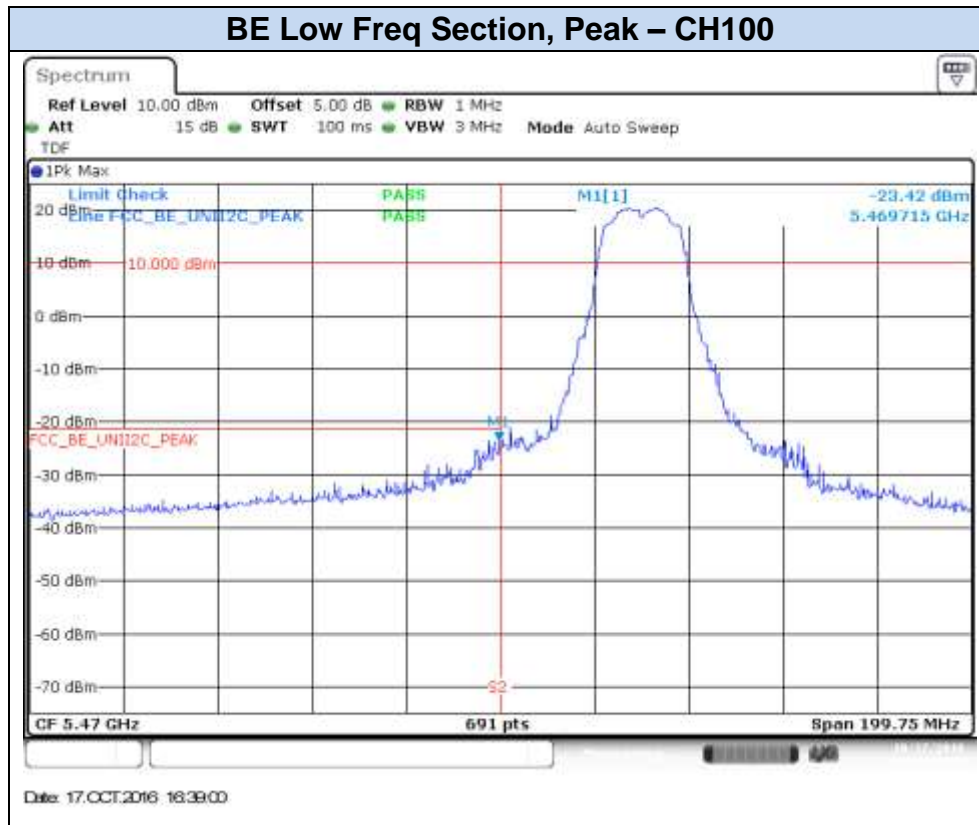
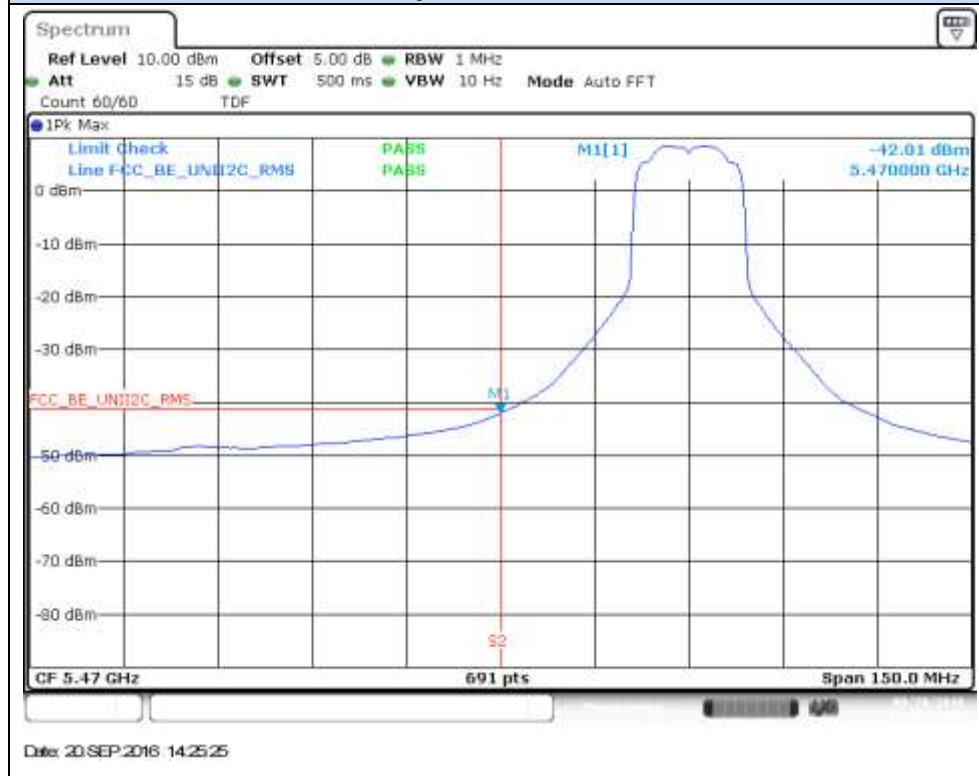
**802.11a, 6Mbps – Chain B****BE Low Freq Section, Peak – CH100****BE Low Freq Section, RMS – CH100**

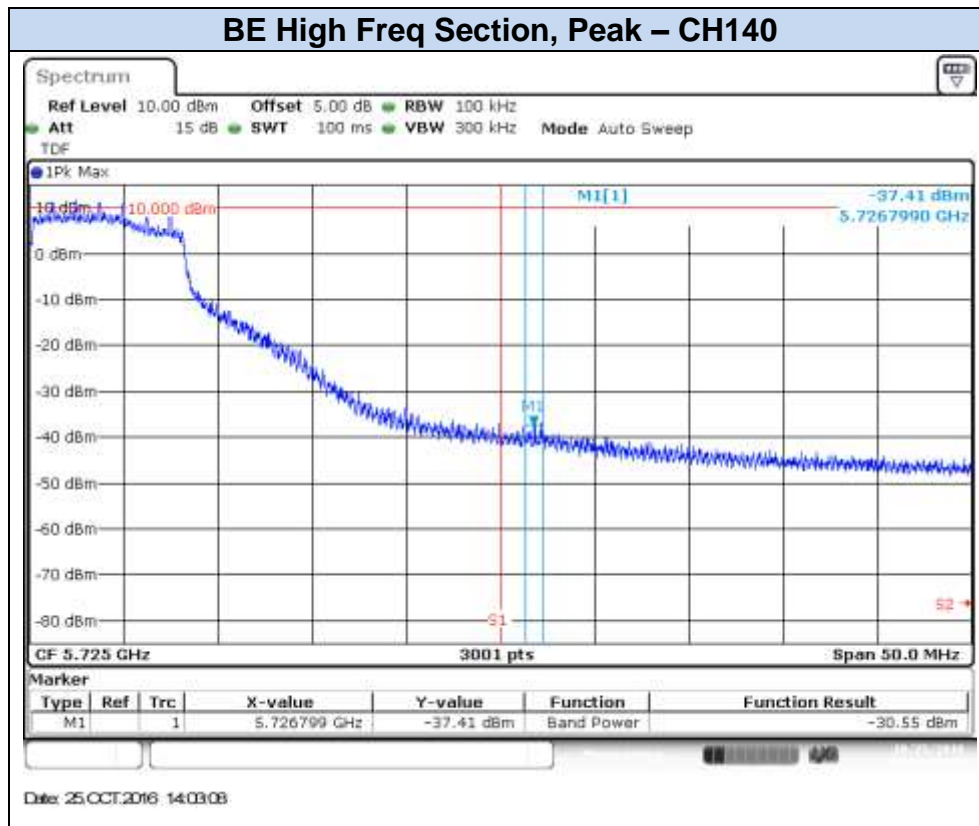

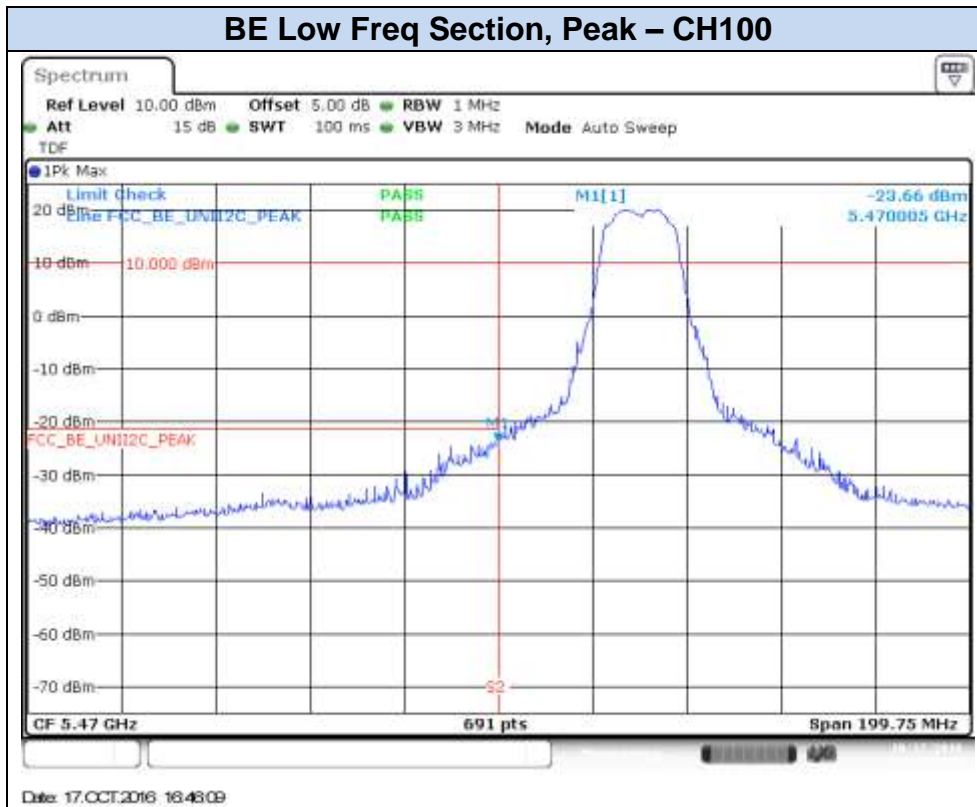
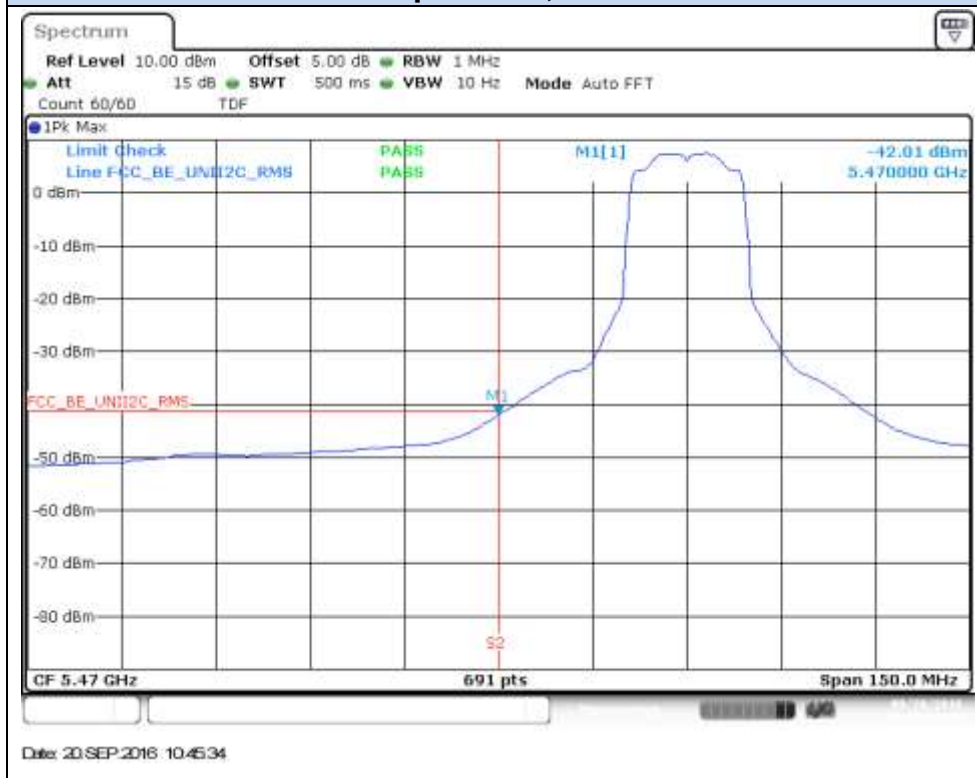
**802.11n20, HT0 (SISO) – Chain A****BE Low Freq Section, Peak – CH100****BE Low Freq Section, RMS – CH100**

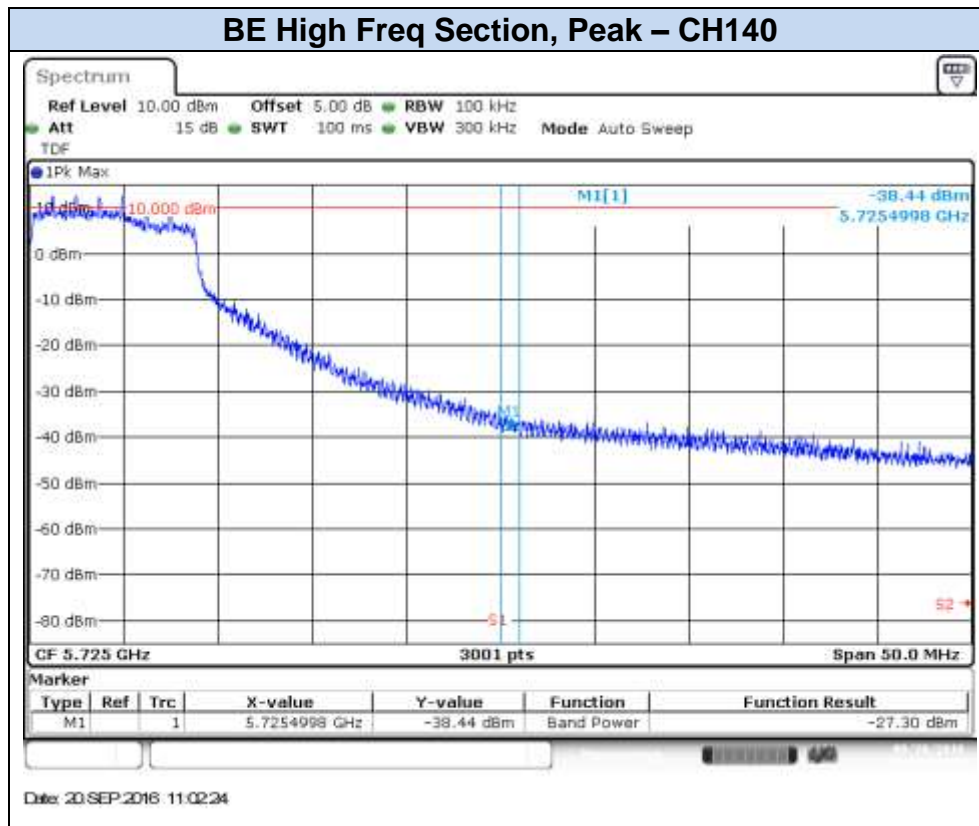

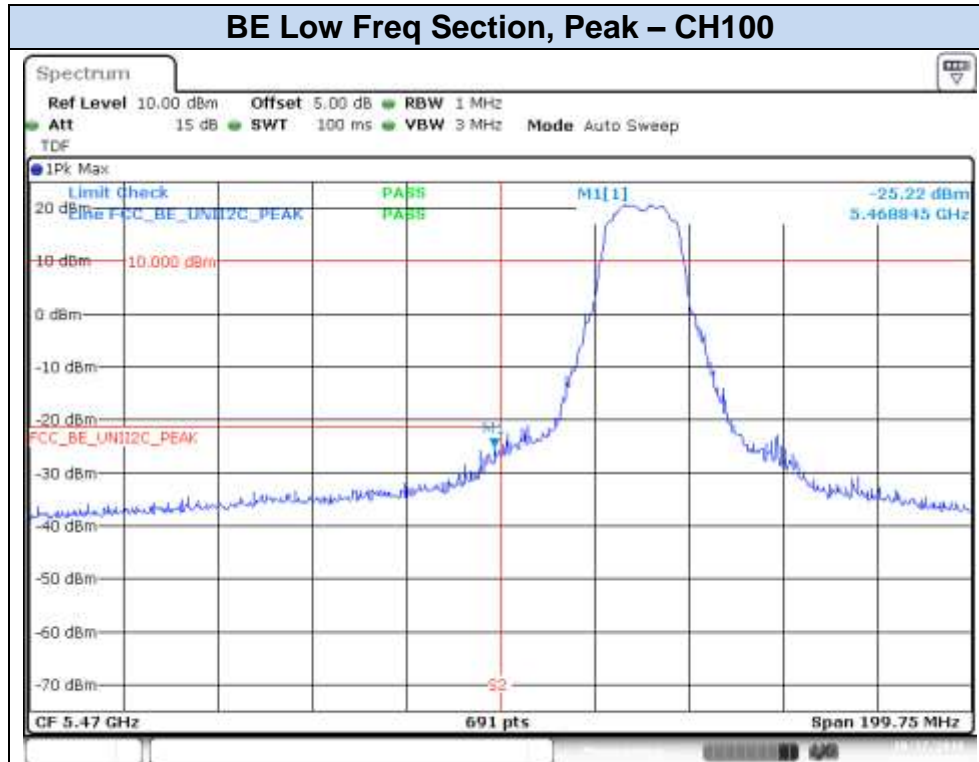
**802.11n20, HT0 (SISO) – Chain B****BE Low Freq Section, Peak – CH100**

Date: 17.OCT.2016 16:42:10

**BE High Freq Section, RMS – CH100**

Date: 20.SEP.2016 14:50:52



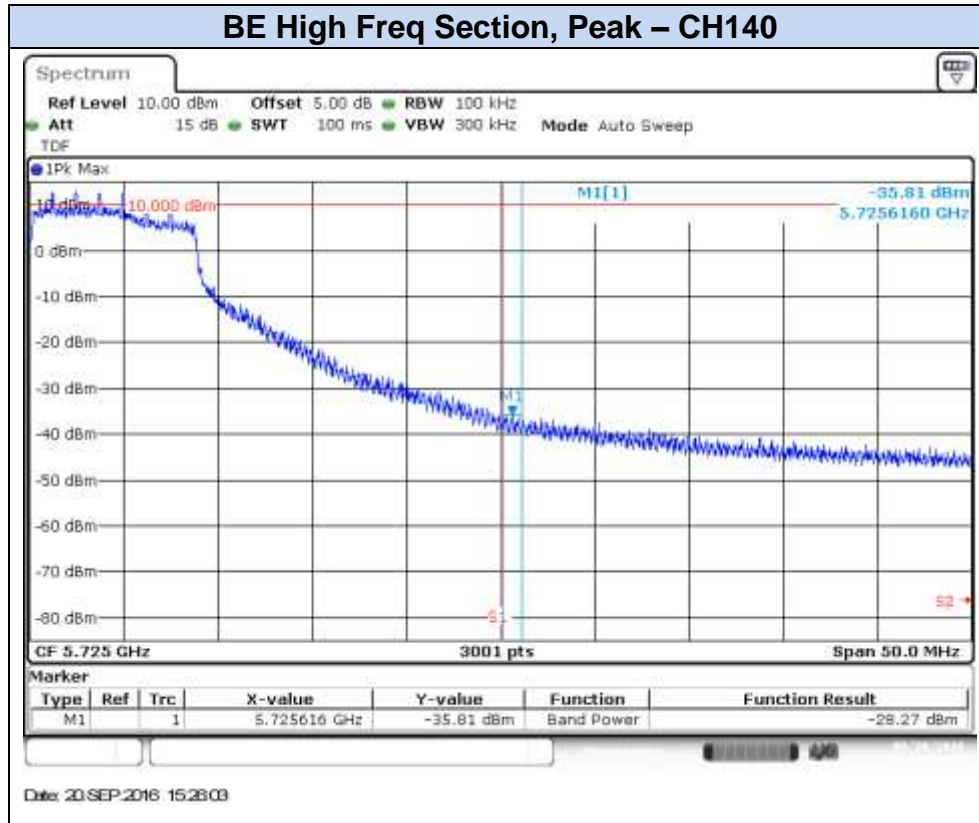

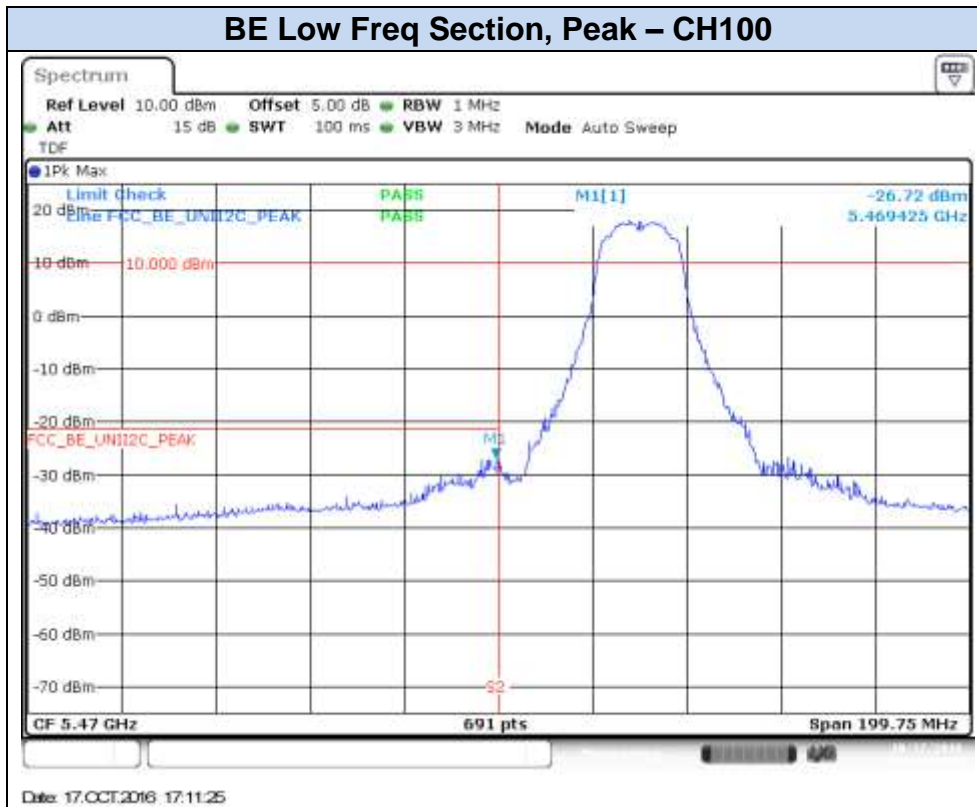
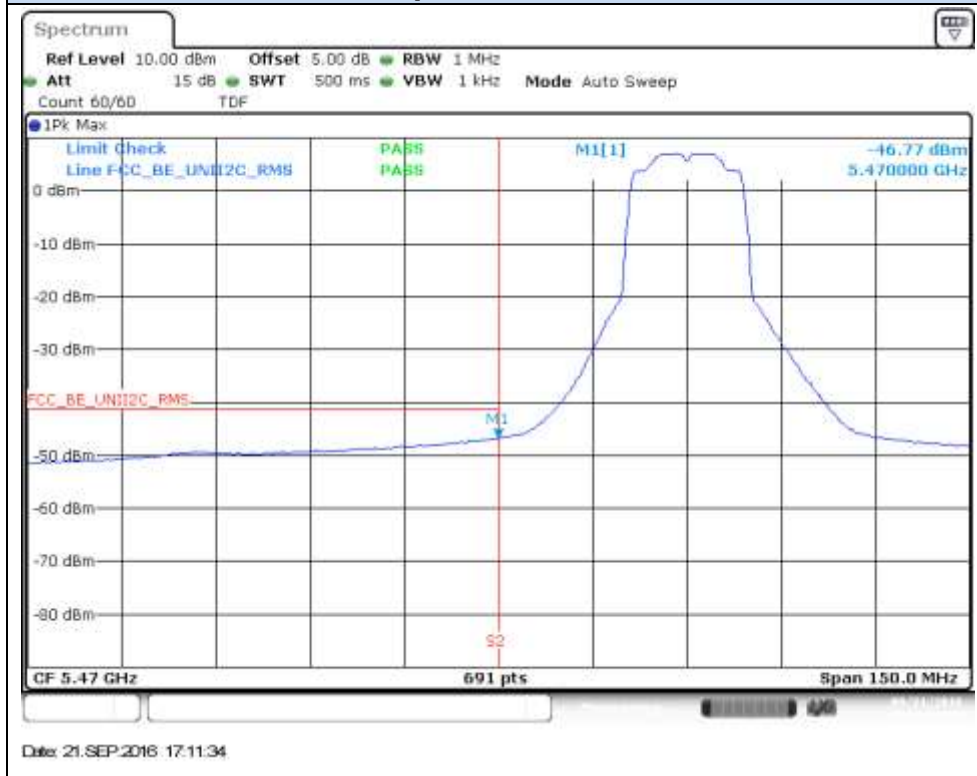
**802.11n20, HT8 (MIMO) – Chain A****BE Low Freq Section, Peak – CH100****BE Low Freq Section, RMS – CH100**



### 802.11n20, HT8 (MIMO) – Chain B

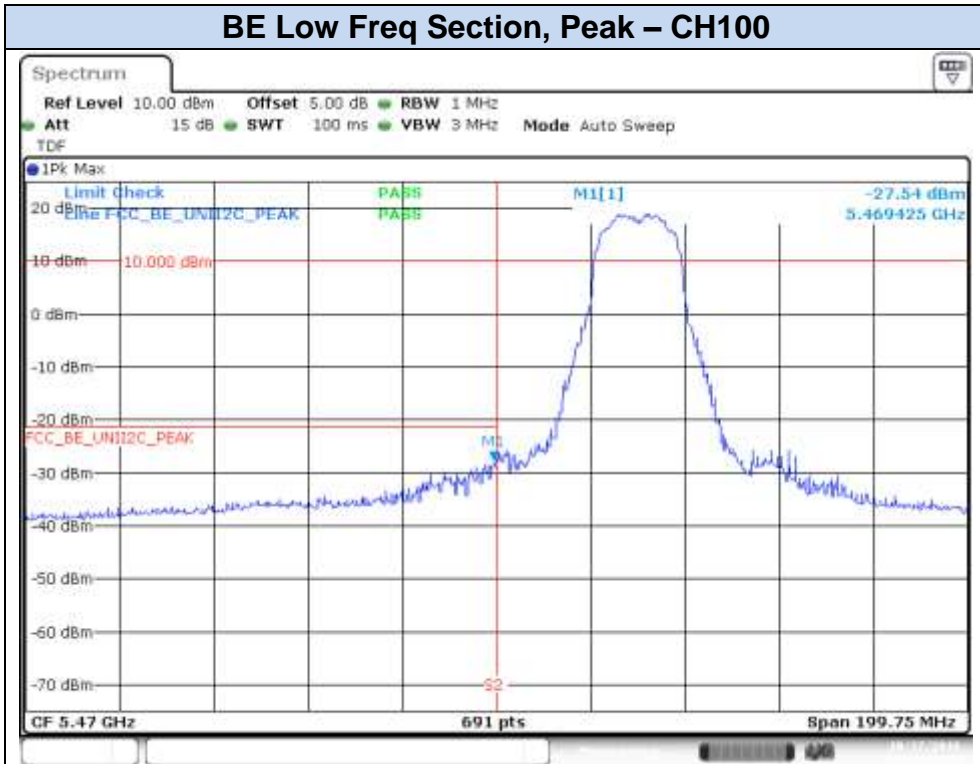

Date: 17.OCT.2016 17:12:21

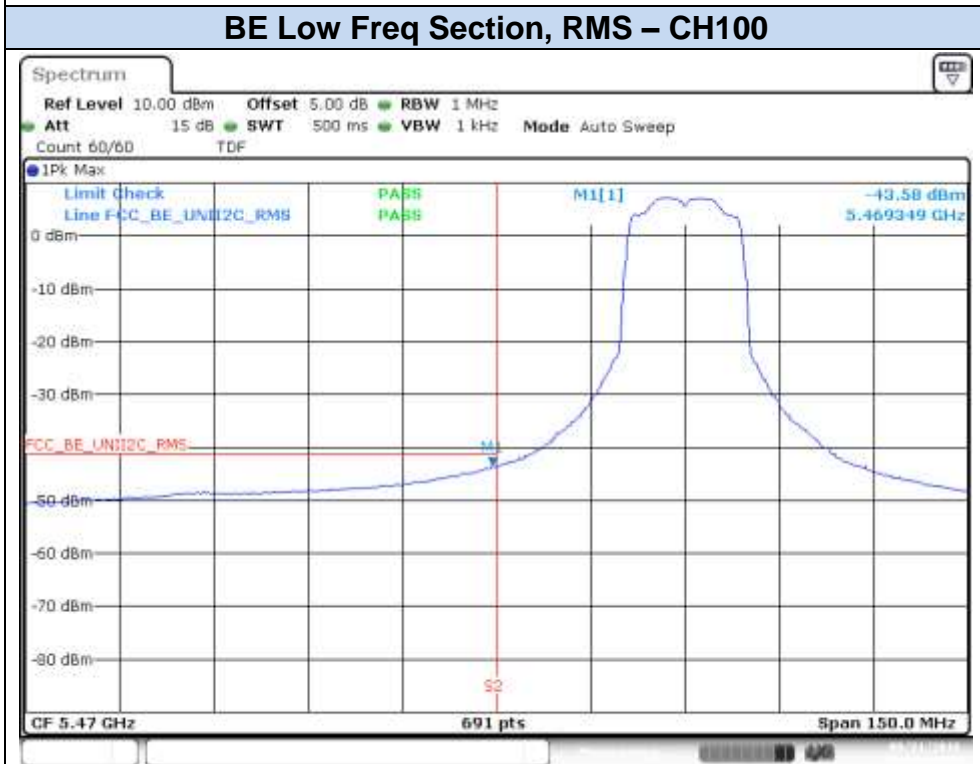

Date: 21.SEP.2016 18:30:14

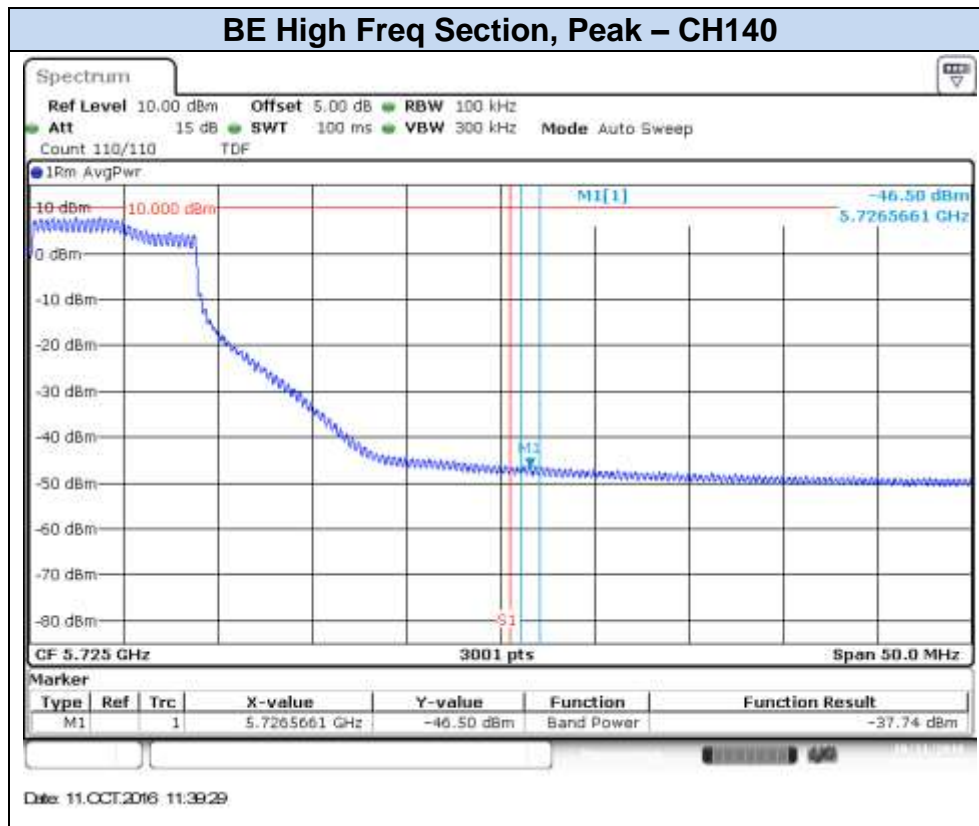

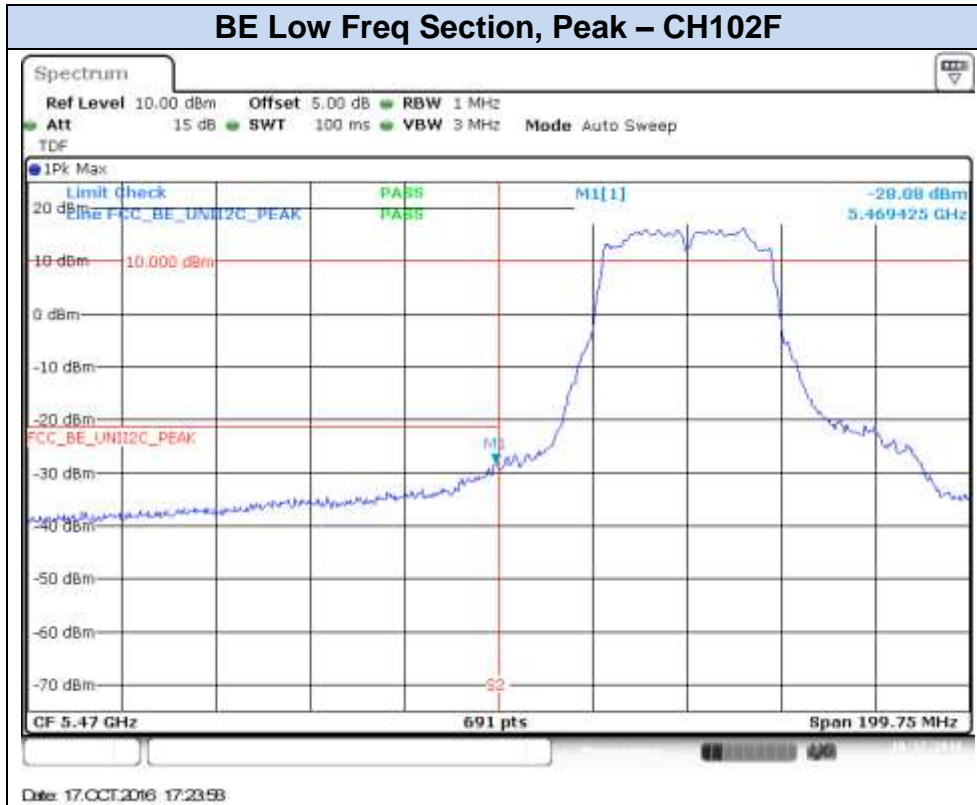
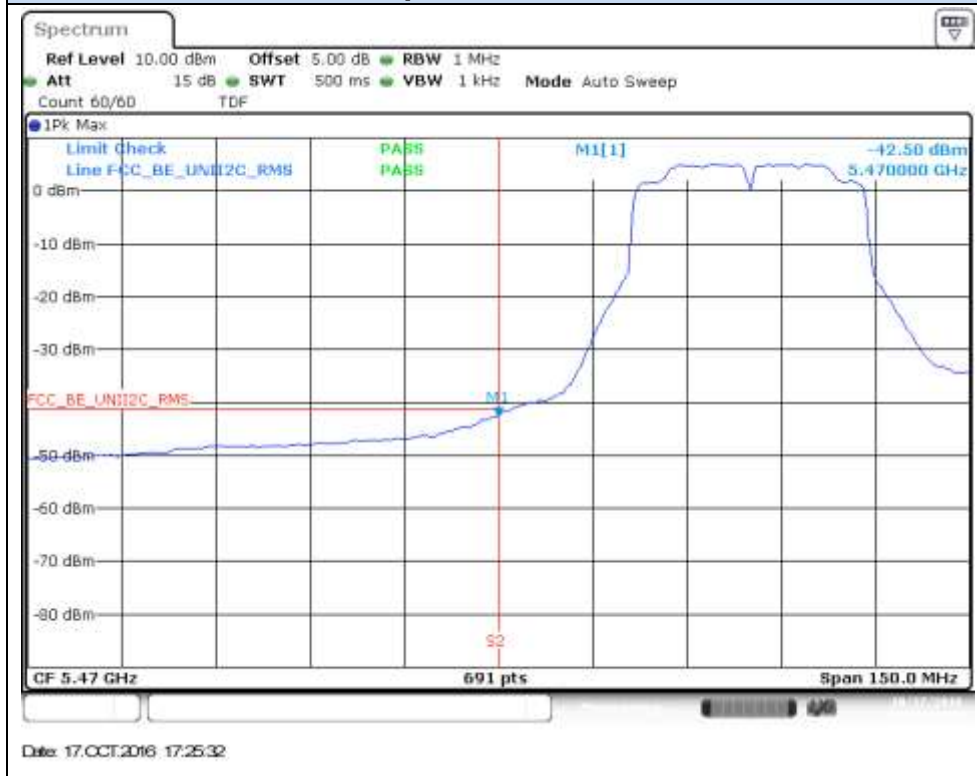
**802.11n40, HT0 (SISO) – Chain A****BE Low Freq Section, Peak – CH102F****BE Low Freq Section, RMS – CH102F**

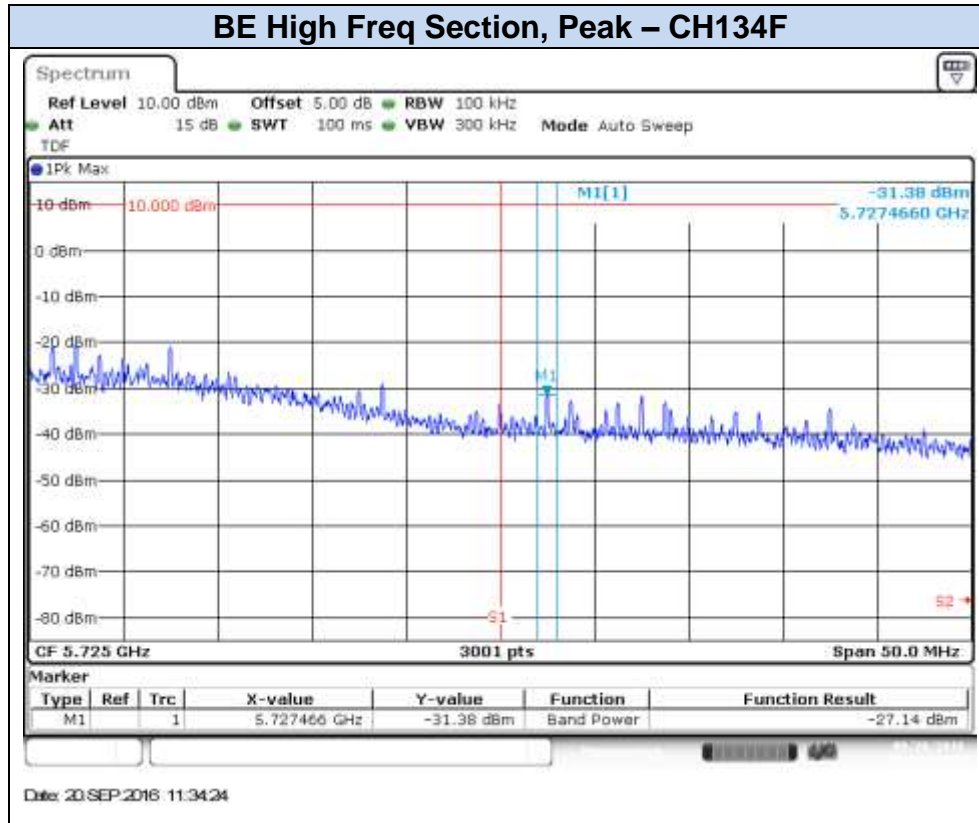

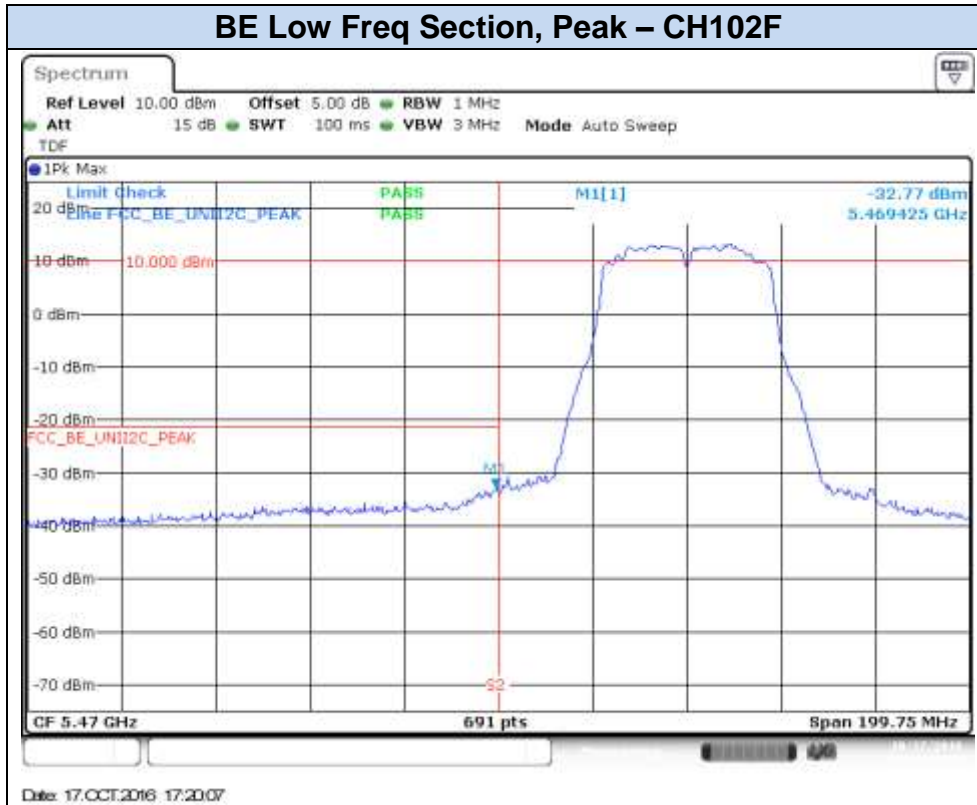
**802.11n40, HT0 (SISO) – Chain B****BE Low Freq Section, Peak – CH102F****BE Low Freq Section, RMS – CH102F**



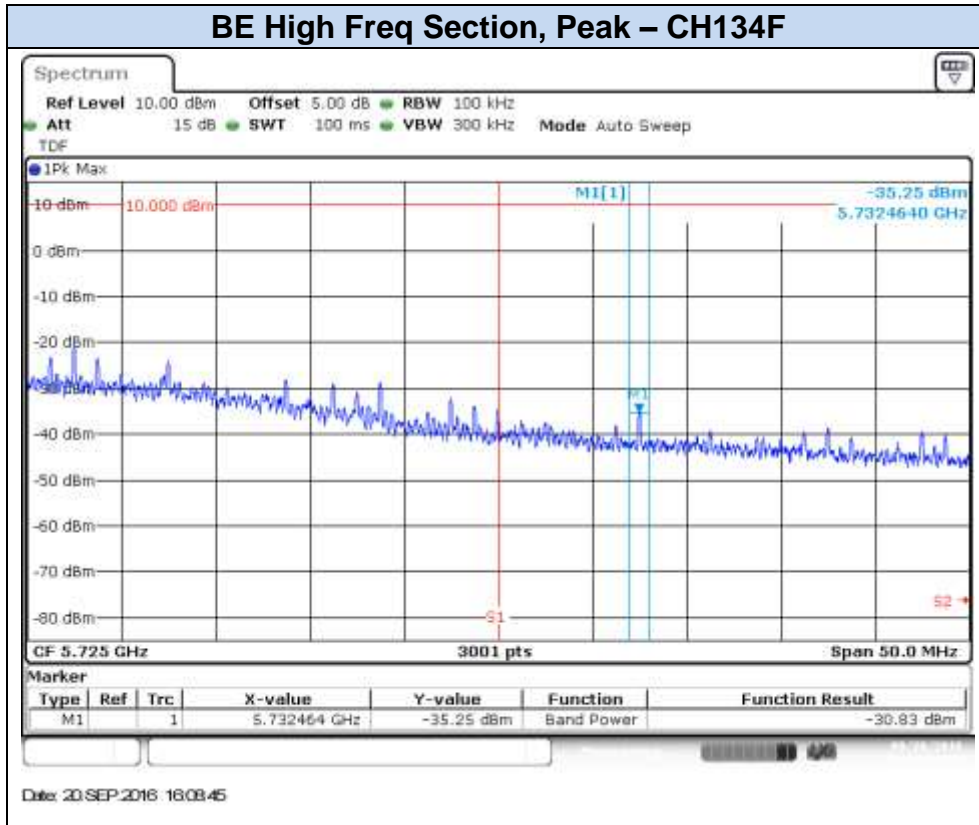

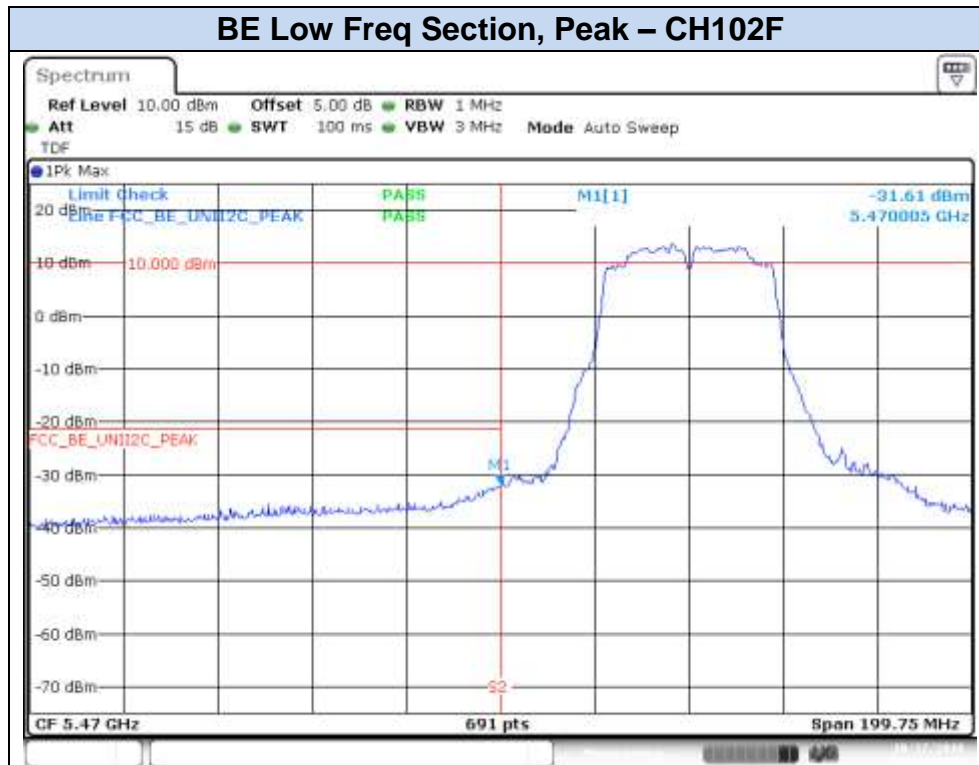
**802.11n40, HT8 (MIMO) – Chain A**

Date: 17.OCT.2016 17:28:32

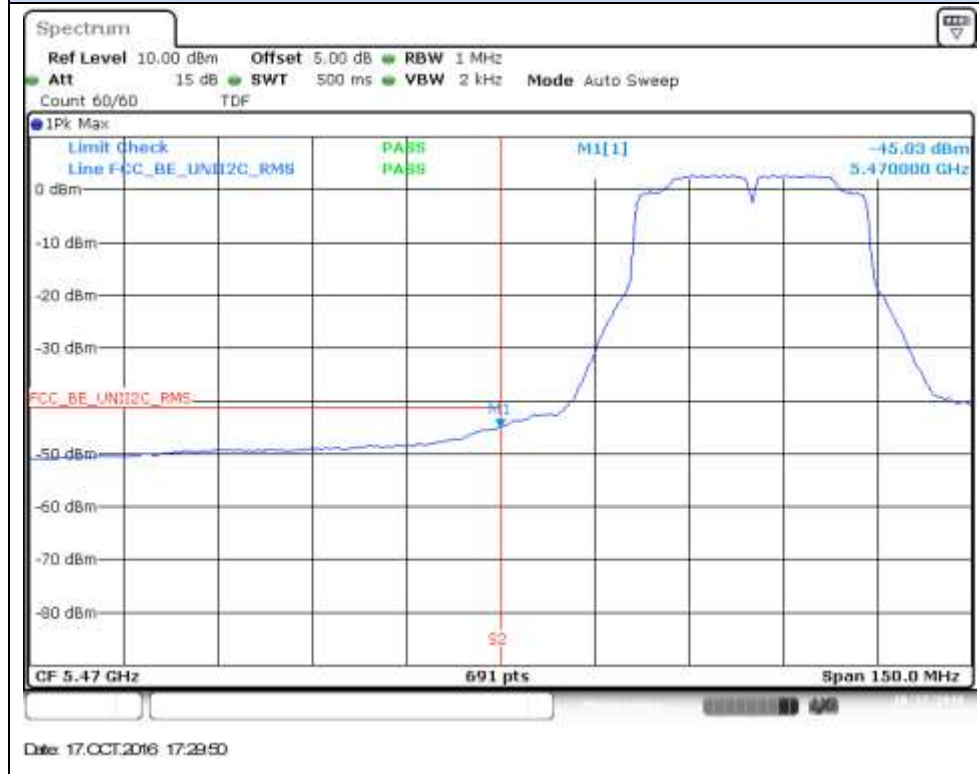
**BE Low Freq Section, RMS – CH102F**

Date: 17.OCT.2016 17:29:50

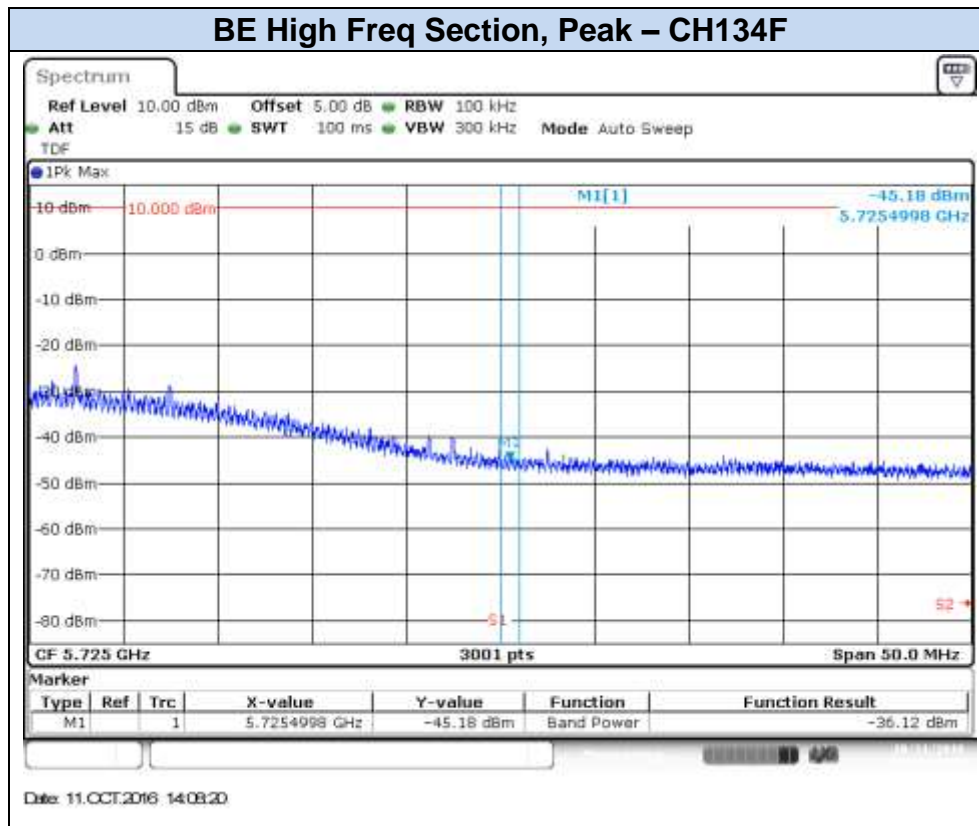

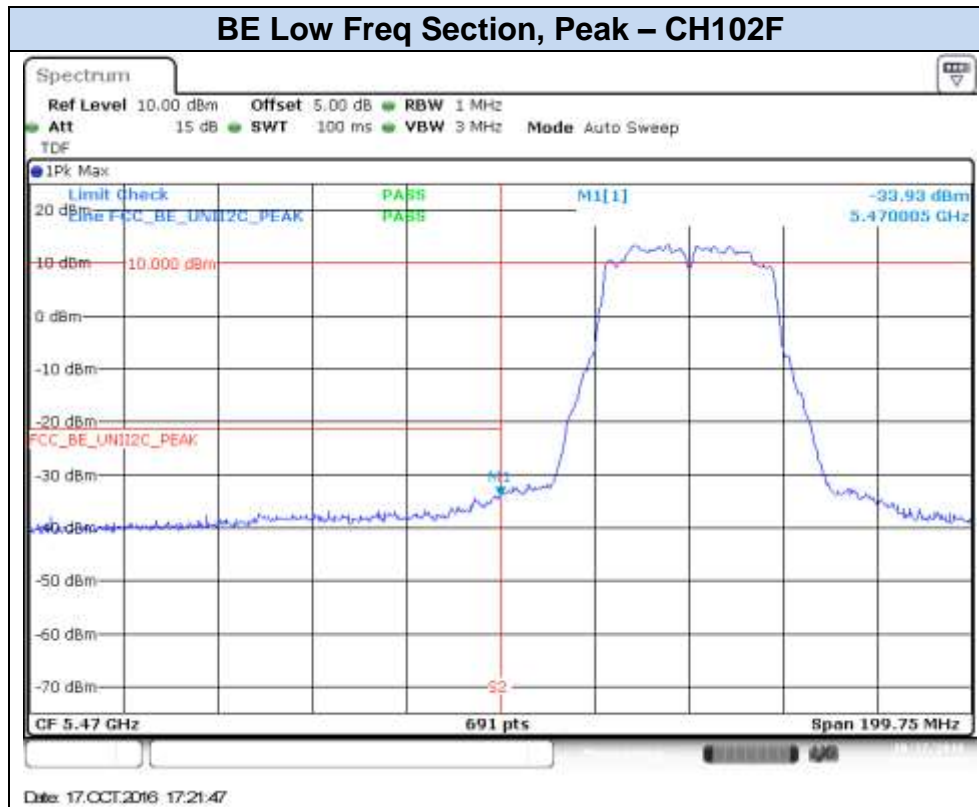
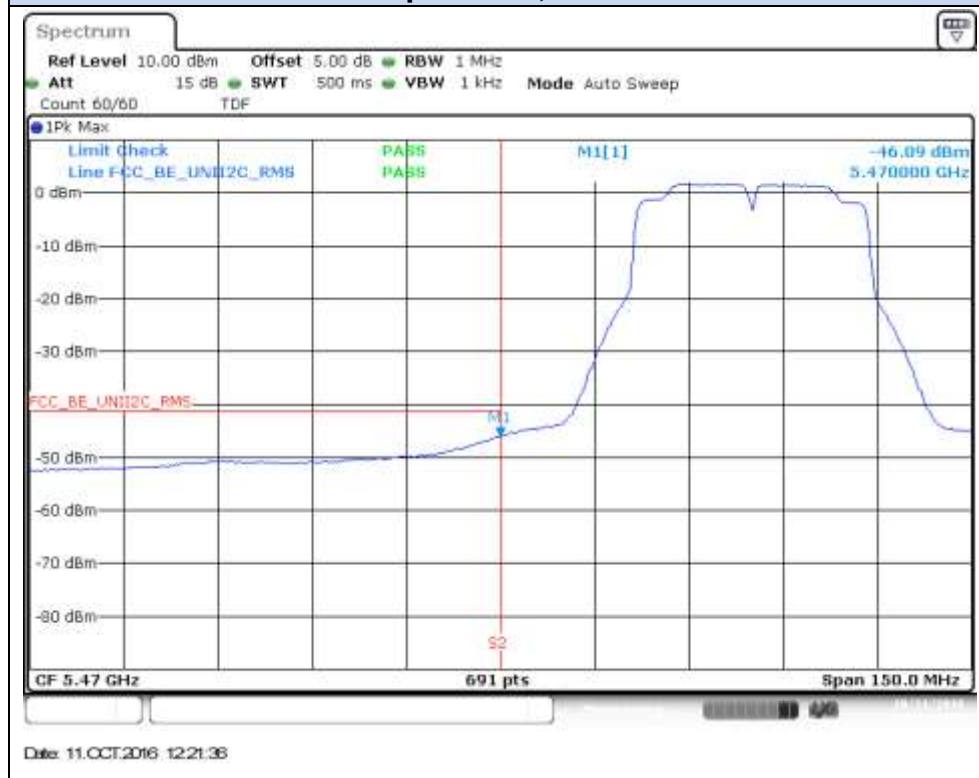
**802.11n40, HT8 (MIMO) – Chain B****BE Low Freq Section, Peak – CH102F****BE Low Freq Section, RMS – CH102F**

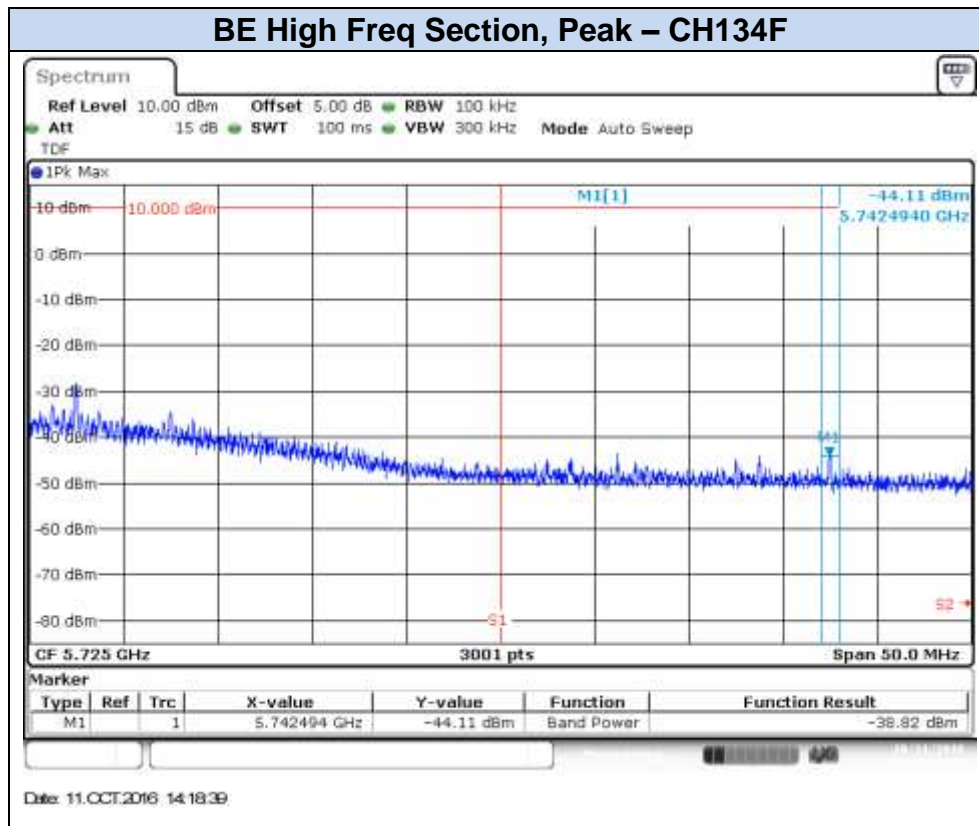

### 802.11ac80, VHT0 (SISO) – Chain A

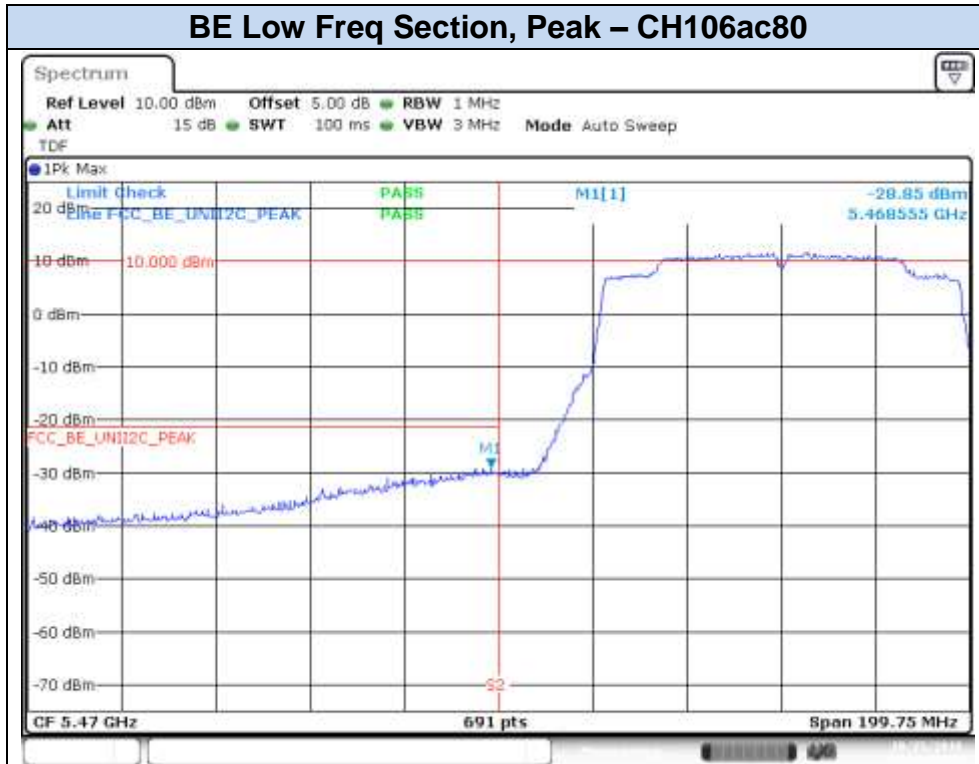

Date: 25.OCT.2016 13:09:36

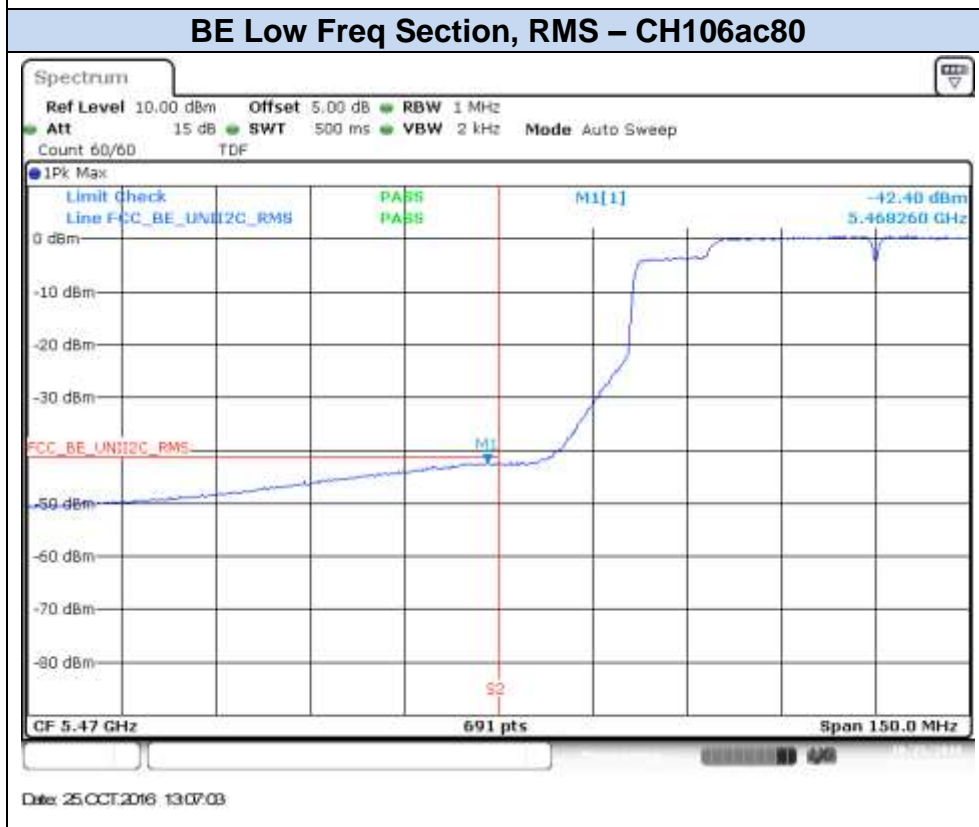

Date: 25.OCT.2016 13:07:03

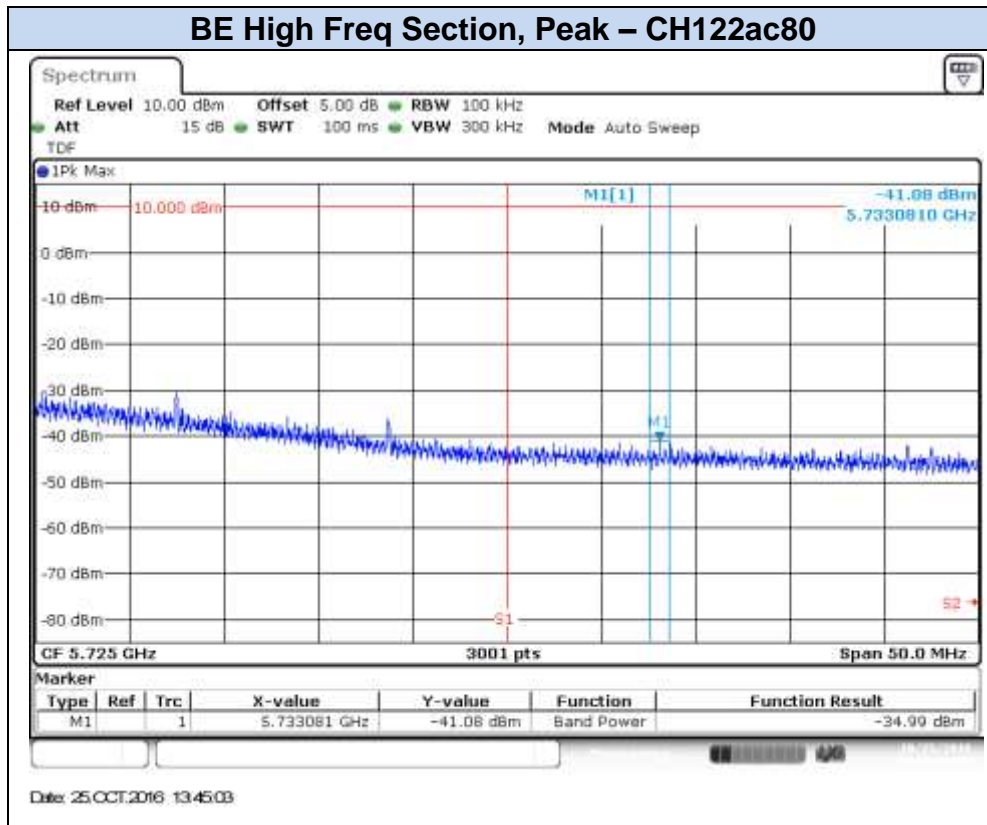

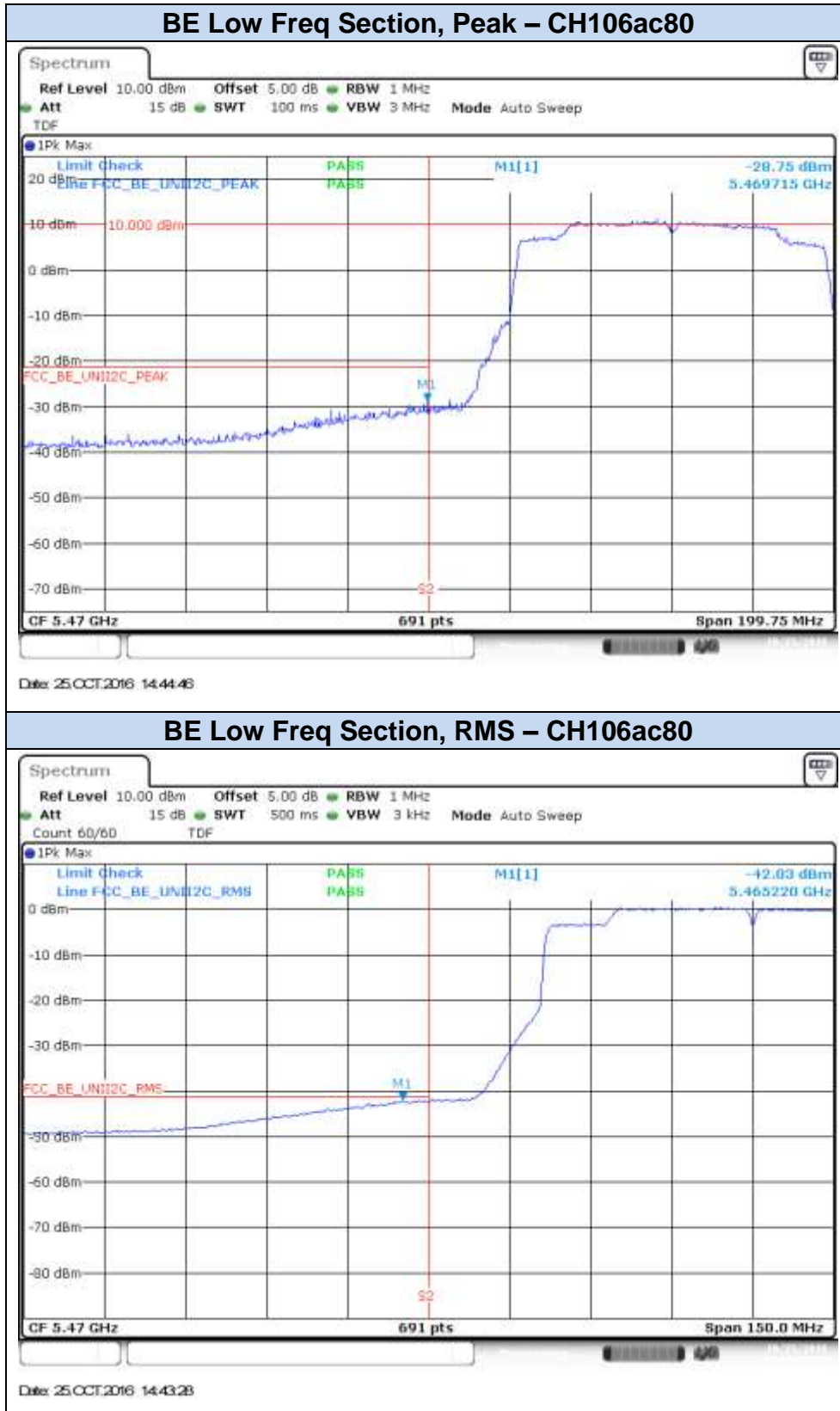
**802.11ac80, VHT0 (SISO) – Chain B**



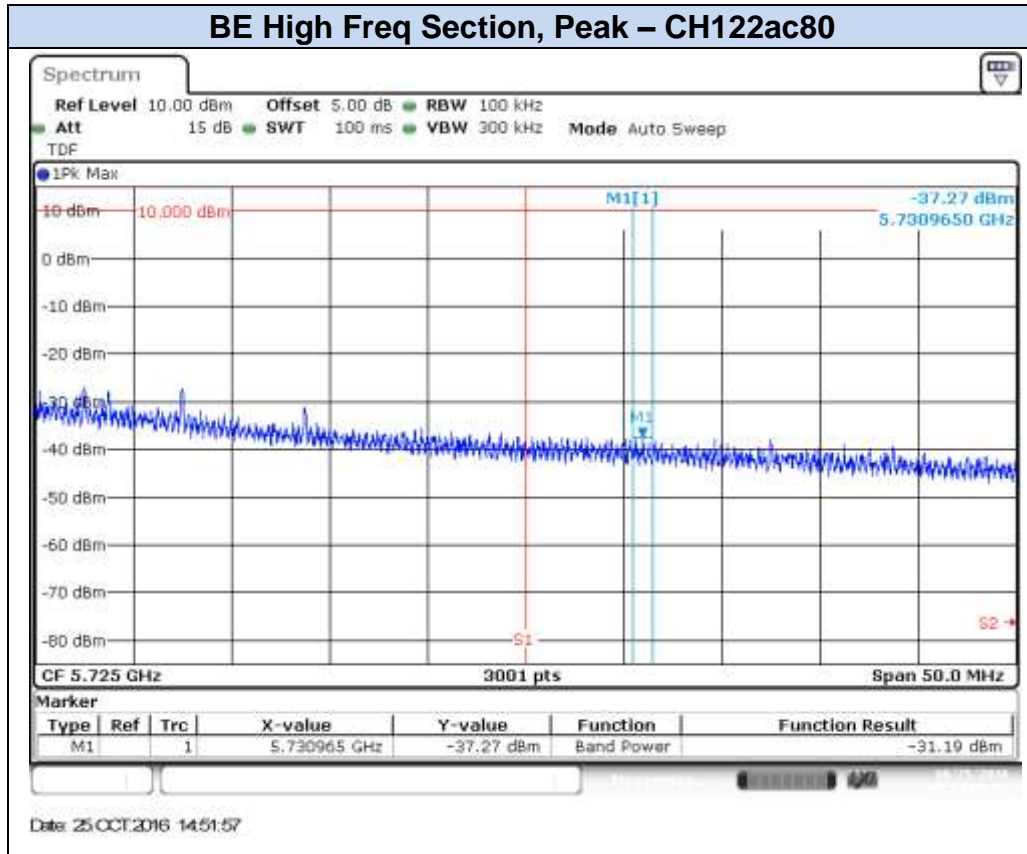

**802.11ac80, VHT0 (MIMO)- Chain A**

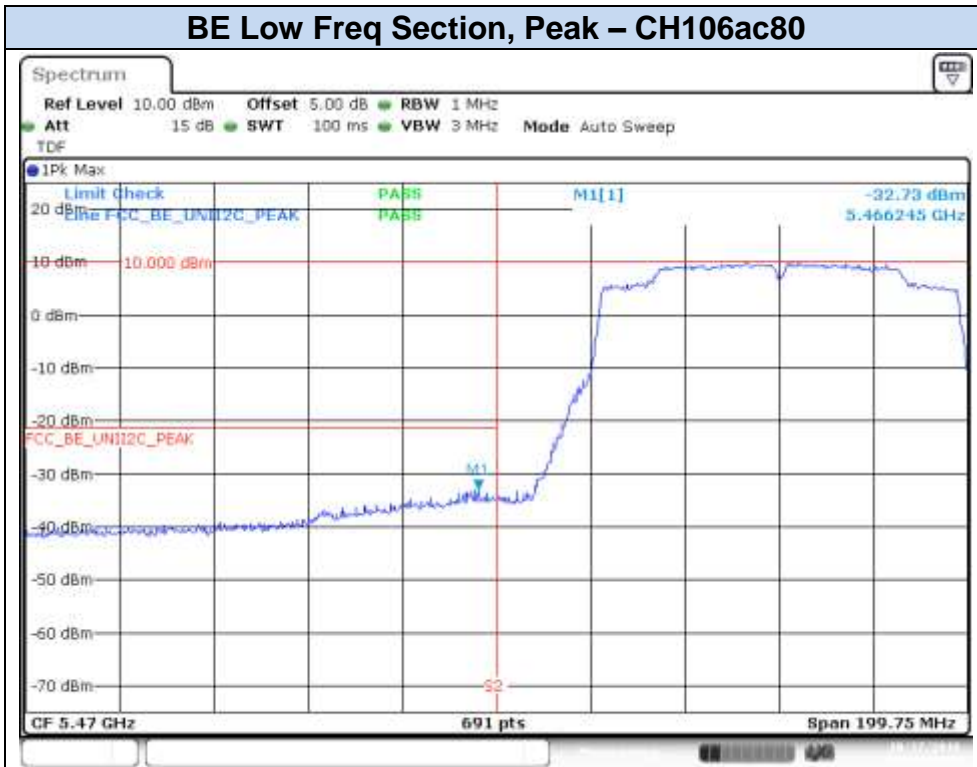

Date: 17.OCT.2016 17:38:15

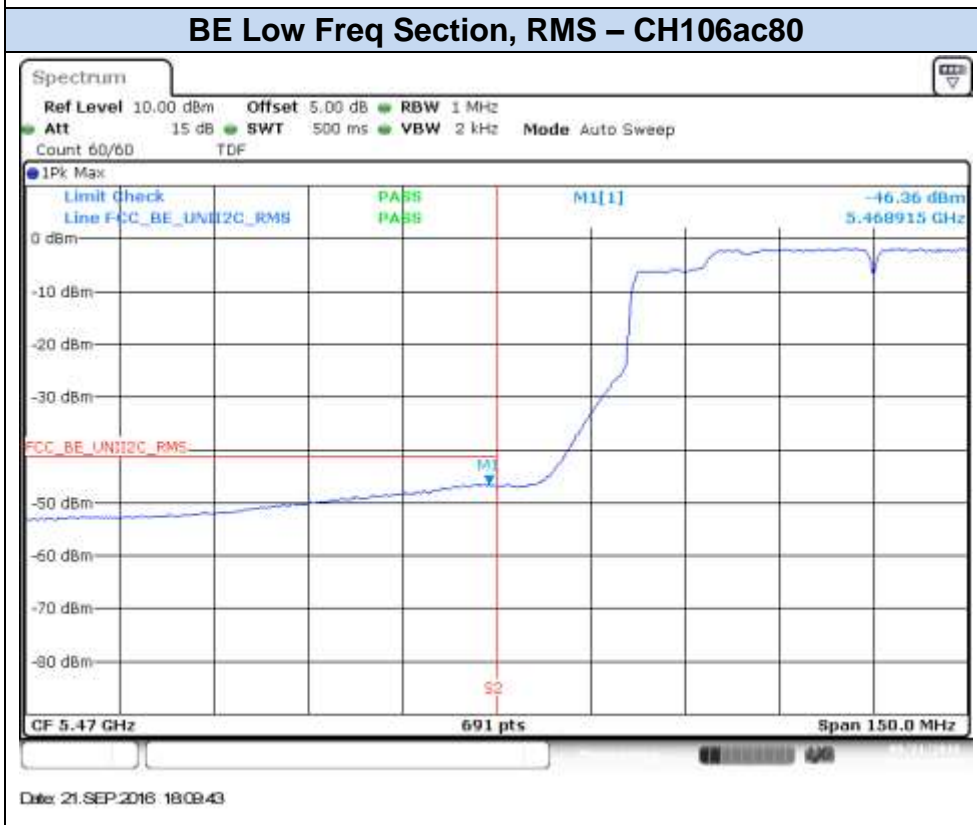

Date: 21.SEP.2016 18:08:43

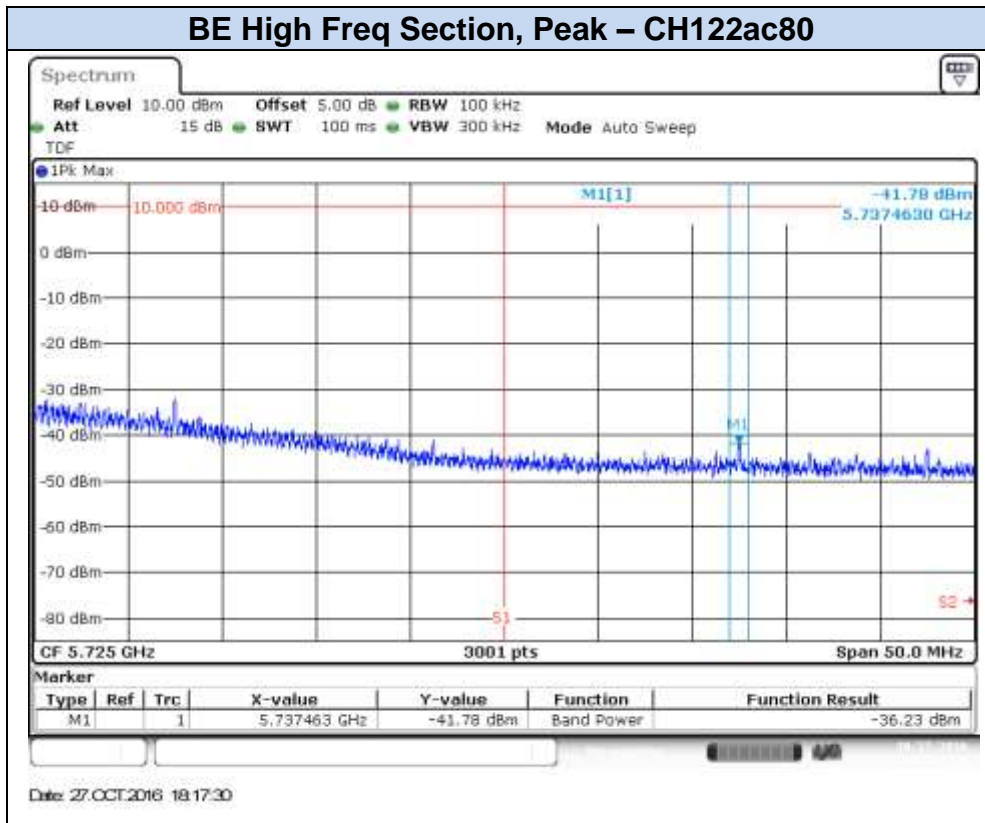

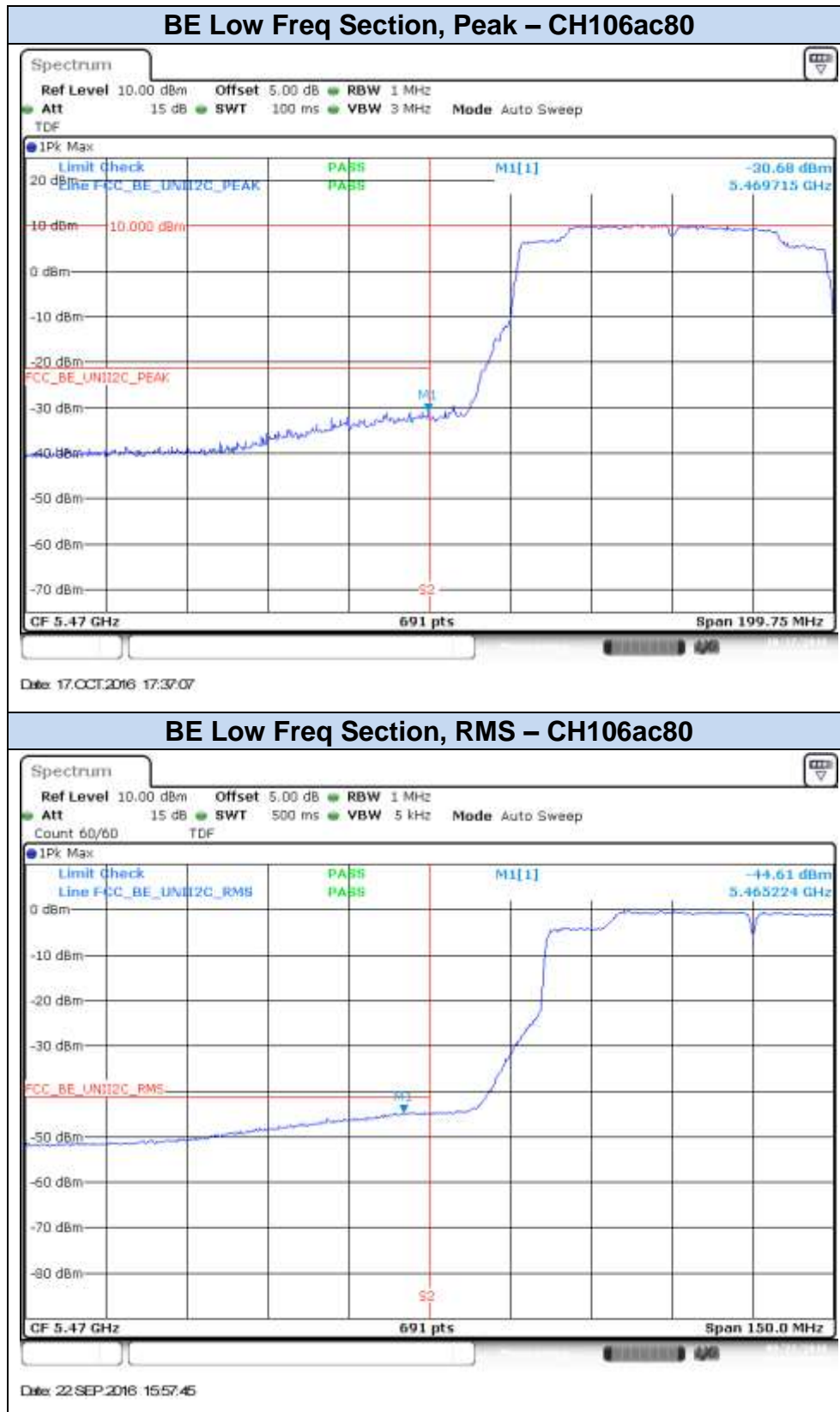
**802.11ac80, VHT0 (MIMO)- Chain B**

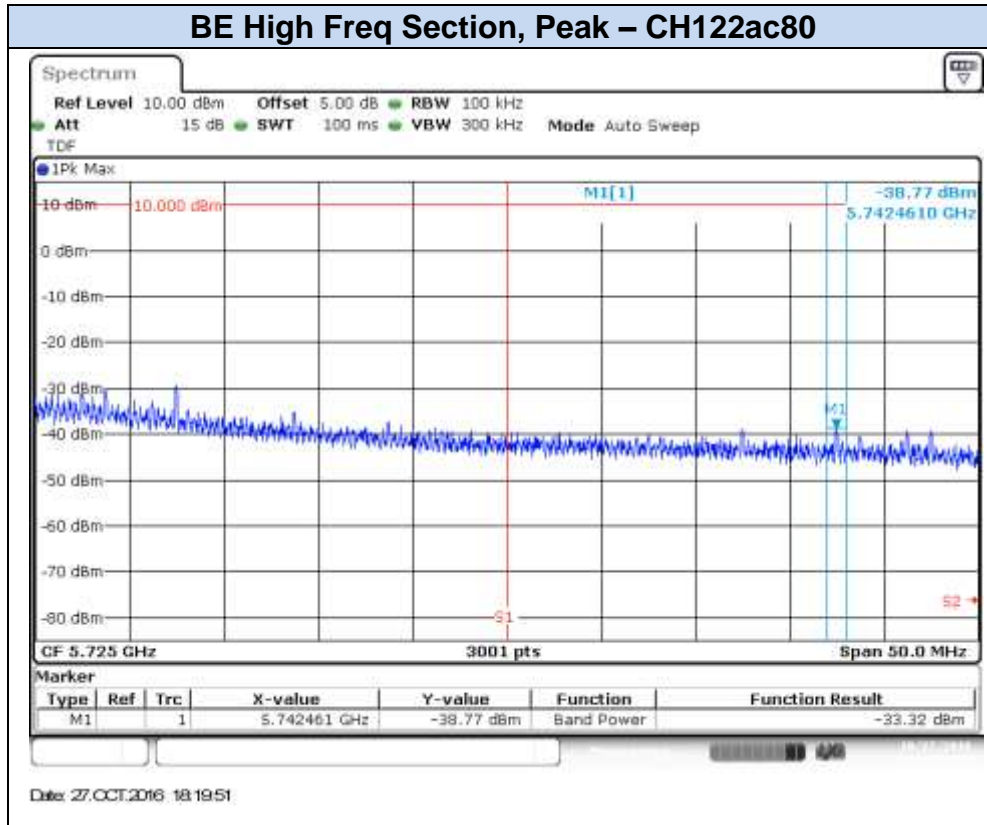

## B.4 Radiated spurious emission

### Standard references:

FCC part	RSS part	Limits																																
15.407 (b) (3)	RSS-247 Clause 6.2.2 (2)	For transmitters operating in the 5.47–5.725 GHz band: all emissions outside of the 5.47–5.725 GHz band shall not exceed an EIRP of -27 dBm/MHz.																																
15.209	RSS-GEN, Clause 8.9	<p>Radiated emissions which fall in the restricted bands, as defined in §15.205(a), must also comply with the radiated emission limits specified in §15.209(a):</p> <table border="1"> <thead> <tr> <th>Freq Range (MHz)</th> <th>Field Strength (μV/m)</th> <th>Field Strength (dBμV/m)</th> <th>Meas. Distance (m)</th> </tr> </thead> <tbody> <tr> <td>0.009-0.490</td> <td>2400/f(kHz)</td> <td>-</td> <td>300</td> </tr> <tr> <td>0.490-1.705</td> <td>24000/f(kHz)</td> <td>-</td> <td>300</td> </tr> <tr> <td>1.705-30.0</td> <td>30</td> <td>-</td> <td>30</td> </tr> <tr> <td>30-88</td> <td>100</td> <td>40</td> <td>3</td> </tr> <tr> <td>88-216</td> <td>150</td> <td>43.5</td> <td>3</td> </tr> <tr> <td>216-960</td> <td>200</td> <td>46</td> <td>3</td> </tr> <tr> <td>Above 960</td> <td>500</td> <td>54</td> <td>3</td> </tr> </tbody> </table> <p>The emission limits shown in the above table are based on measurements employing CISPR quasi-peak detector except for the frequency bands 9-90 kHz, 110-490 kHz and above 1000 MHz. Radiated emission limits in these three bands are based on measurements employing an average detector.</p> <p>For average radiated emission measurements above 1000 MHz, there is also a limit specified when measuring with peak detector function, corresponding to 20 dB above the indicated values in the table.</p>	Freq Range (MHz)	Field Strength (μV/m)	Field Strength (dBμV/m)	Meas. Distance (m)	0.009-0.490	2400/f(kHz)	-	300	0.490-1.705	24000/f(kHz)	-	300	1.705-30.0	30	-	30	30-88	100	40	3	88-216	150	43.5	3	216-960	200	46	3	Above 960	500	54	3
Freq Range (MHz)	Field Strength (μV/m)	Field Strength (dBμV/m)	Meas. Distance (m)																															
0.009-0.490	2400/f(kHz)	-	300																															
0.490-1.705	24000/f(kHz)	-	300																															
1.705-30.0	30	-	30																															
30-88	100	40	3																															
88-216	150	43.5	3																															
216-960	200	46	3																															
Above 960	500	54	3																															

### Test procedure:

The below setups were used to measure the radiated spurious emissions.

Depending of the frequency range and bands being tested, different antennas and filters were used.

The final measurement is done by varying the antenna height from, the EUT azimuth over 360° and for both Vertical and Horizontal polarizations.

The radiated spurious emissions were measured on the worst case configuration selected from the chapter B.2 and using the lowest, middle and highest channels.

For technologies 802.n20, 802.n40 and 802.ac80 the worst case in terms of spurious emissions found among the low, mid and high channels when tested on chain A and B separately is used to perform the test in MIMO mode (Chain A+B).

*Radiated Setup < 1GHz*

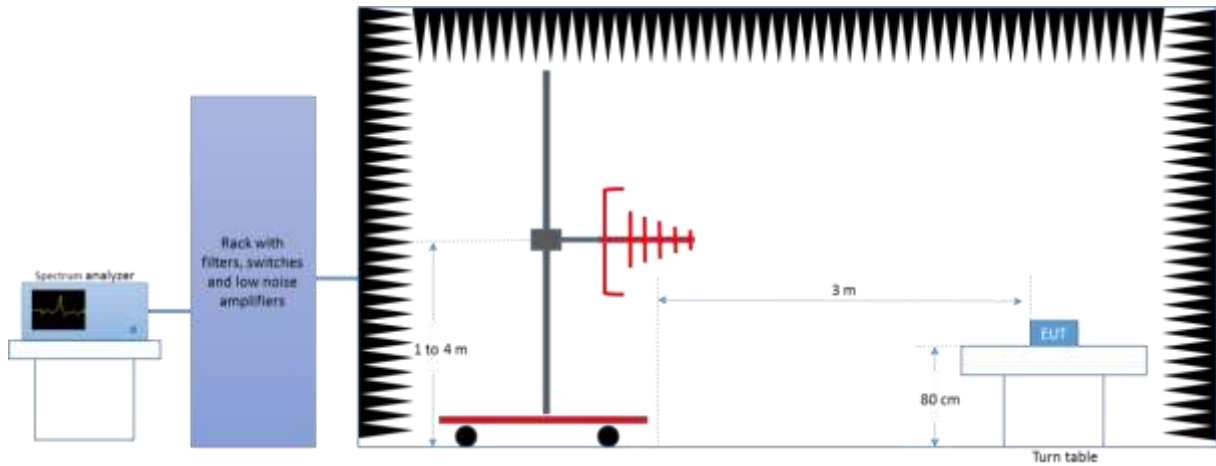

*Radiated Setup 1 GHz - 18 GHz*

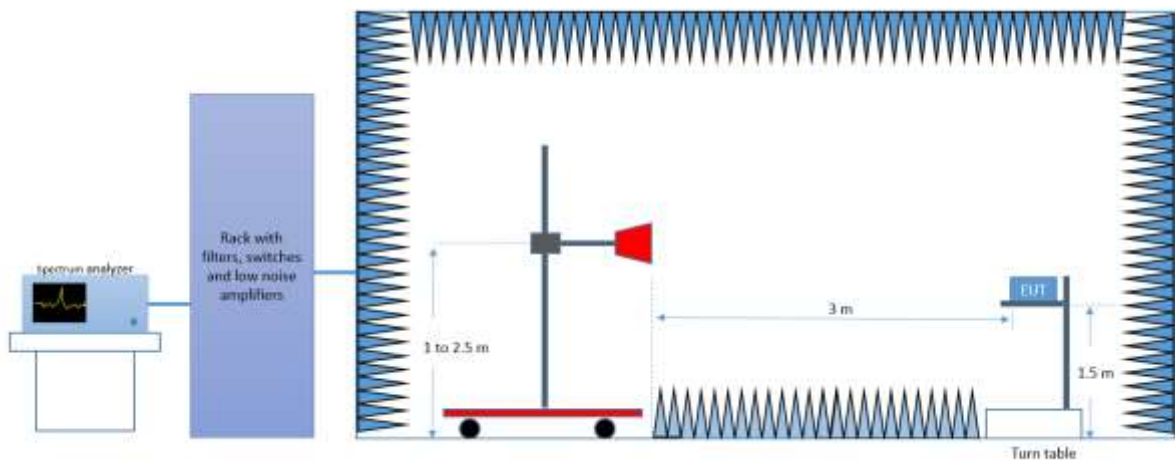

*Radiated Setup 18 GHz - 26.5 GHz*

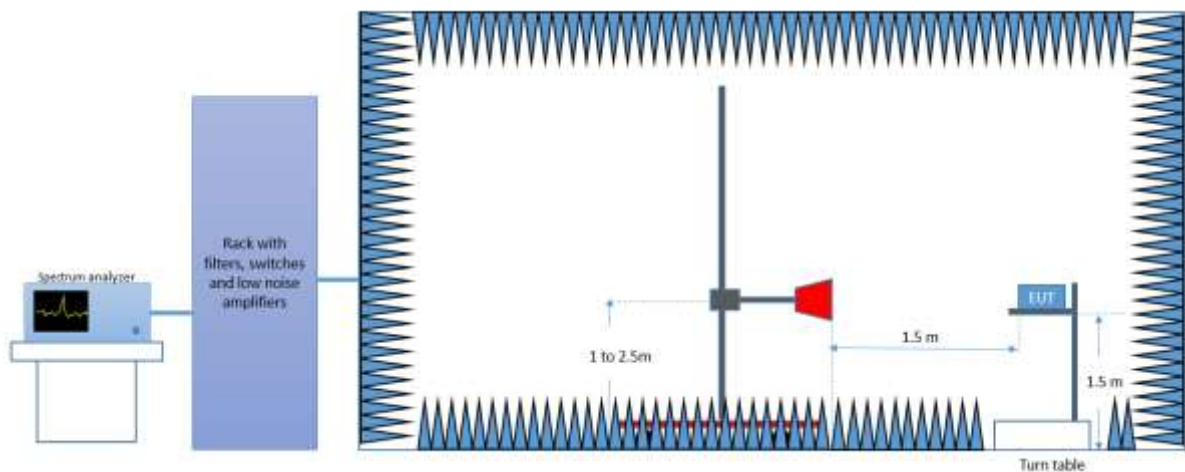

*Radiated Setup > 26.5 GHz*

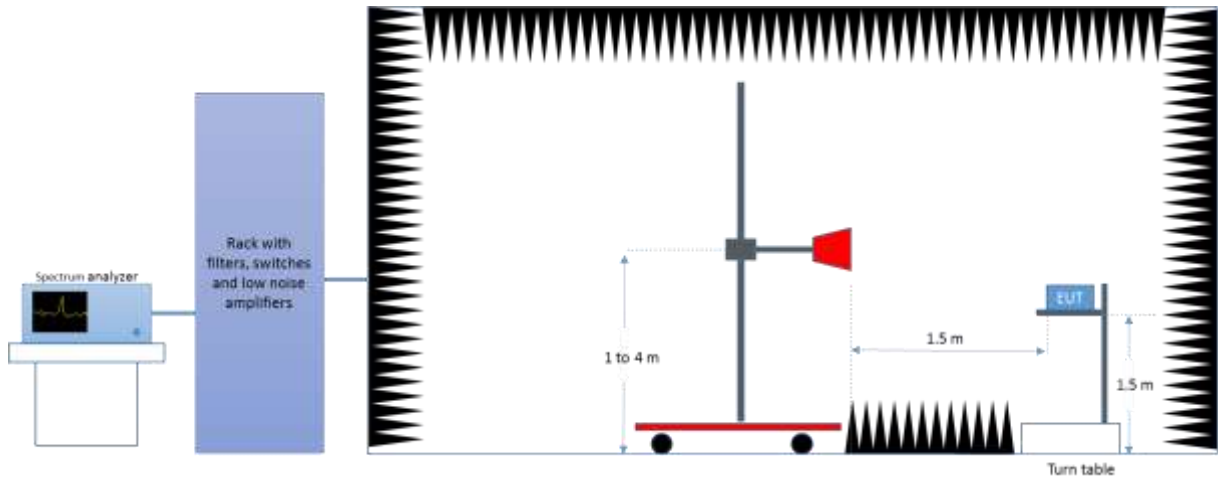



**Test Results:**

**Radiated Spurious – 30MHz to 1GHz**

**Radiated Spurious – All modes**

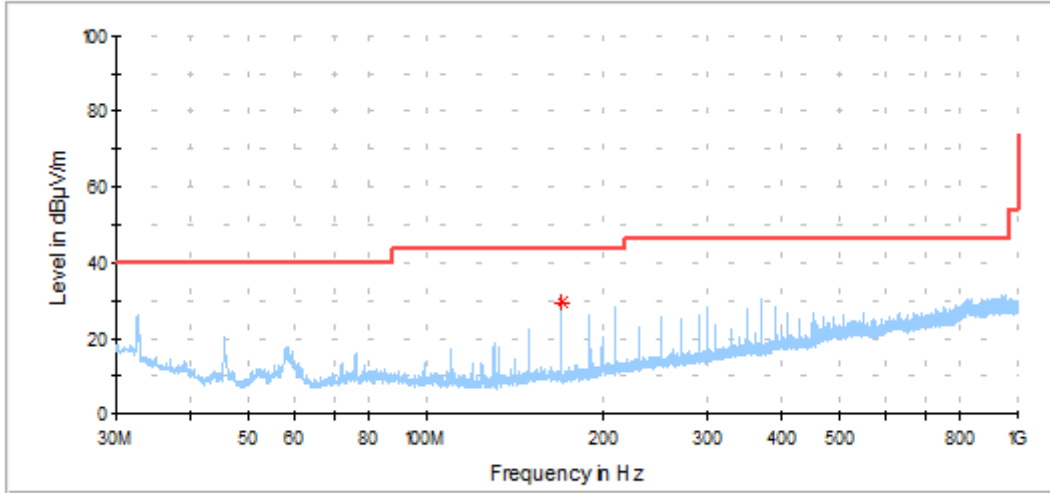

— Peak measurements      — Limit FCC Peak

Frequency	MaxPeak	Limit	Margin
MHz	dBuV/m	dBuV/m	dB
170.0	29.2	43.6	14.3

Note 1: The spurious signals detected do not depend on either the operating channel or the modulation mode.

**1 GHz – 18 GHz, 802.11a, 6Mbps, Chain A**

**Radiated Spurious – CH100**

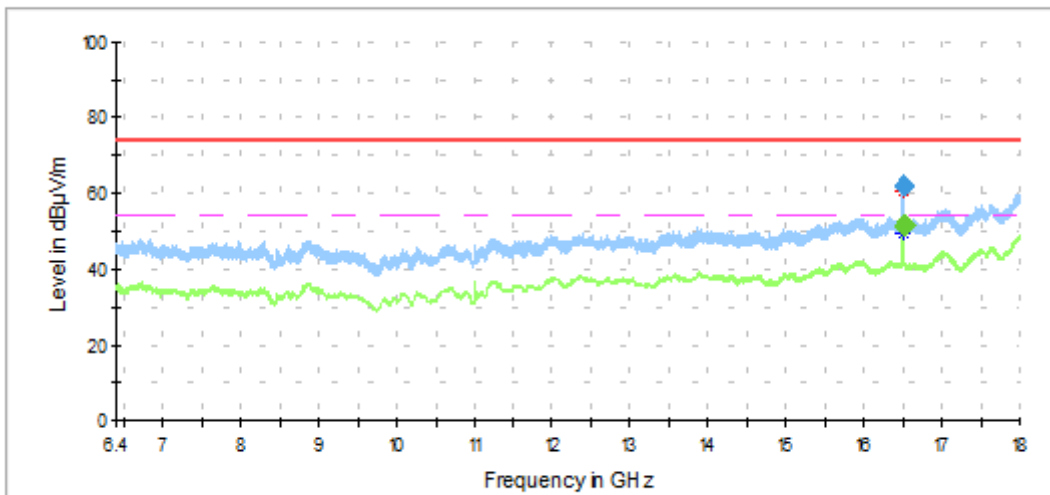
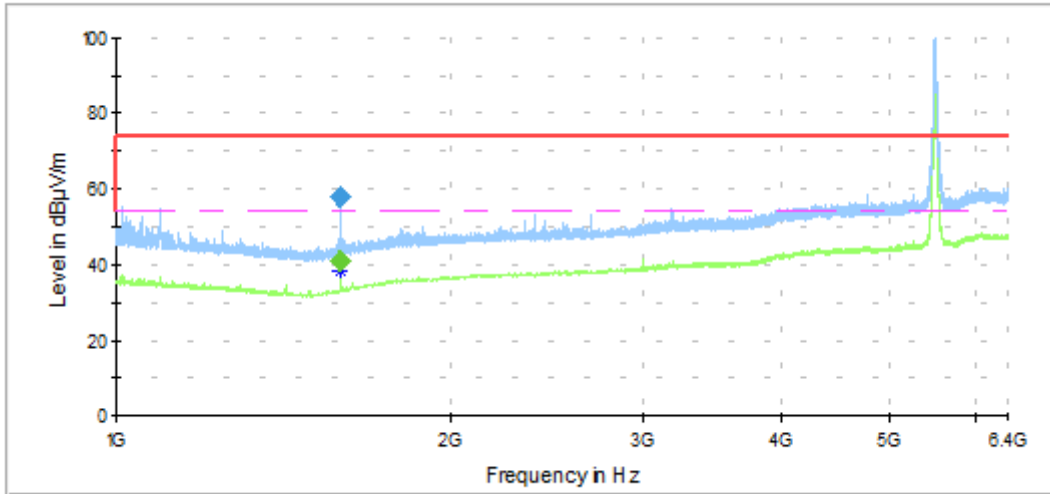

— Peak measurements     
 — Avg measurements     
 — Limit FCC Peak     
 - - - Limit FCC Avg

Frequency	MaxPeak	Avg	Limit	Margin
MHz	dBuV/m	dBuV/m	dBuV/m	dB
1593.3	57.7	---	74.0	16.3
1595.7	---	41.2	54.0	12.8
16501.8	---	51.7	54.0	2.3
16505.8	62.2	---	74.0	11.8

### Radiated Spurious – CH120

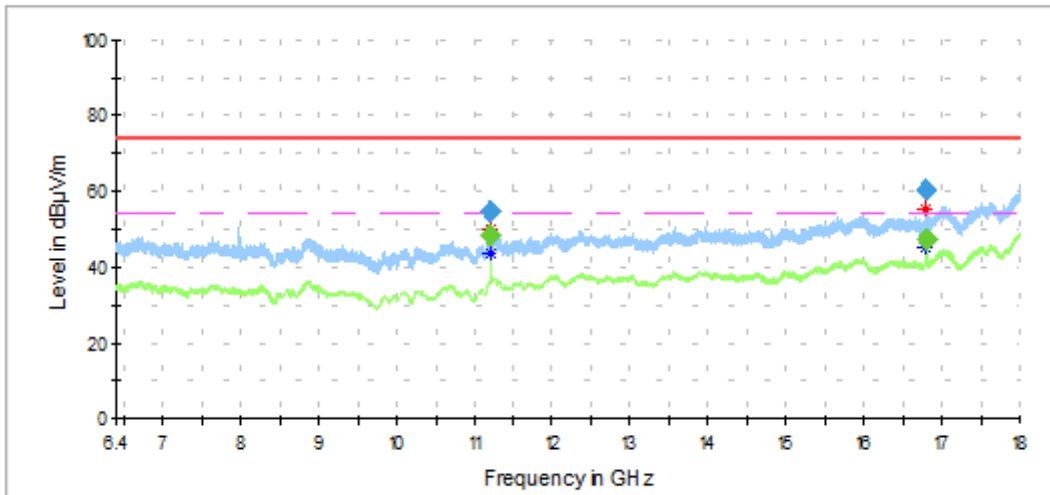
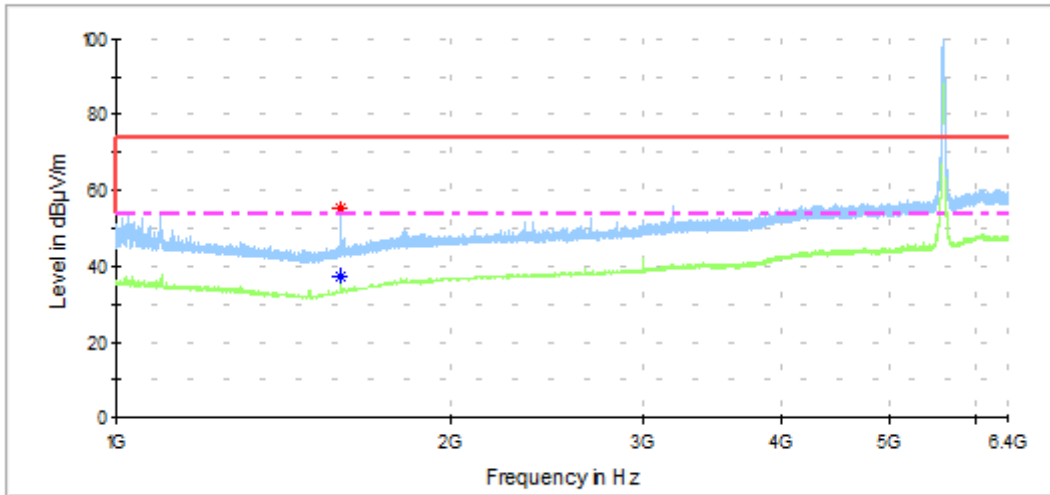

— Peak measurements     
 — Avg measurements     
 — Limit FCC Peak     
 - - - Limit FCC Avg

Frequency	MaxPeak	Avg	Limit	Margin
MHz	dBuV/m	dBuV/m	dBuV/m	dB
1594.7	55.4	---	74.0	18.6
1595.2	---	37.5	54.0	16.5
11199.7	---	48.2	54.0	5.8
11199.7	54.6	---	74.0	19.4
16798.1	---	47.2	54.0	6.8
16804.3	60.7	---	74.0	13.3

### Radiated Spurious – CH140

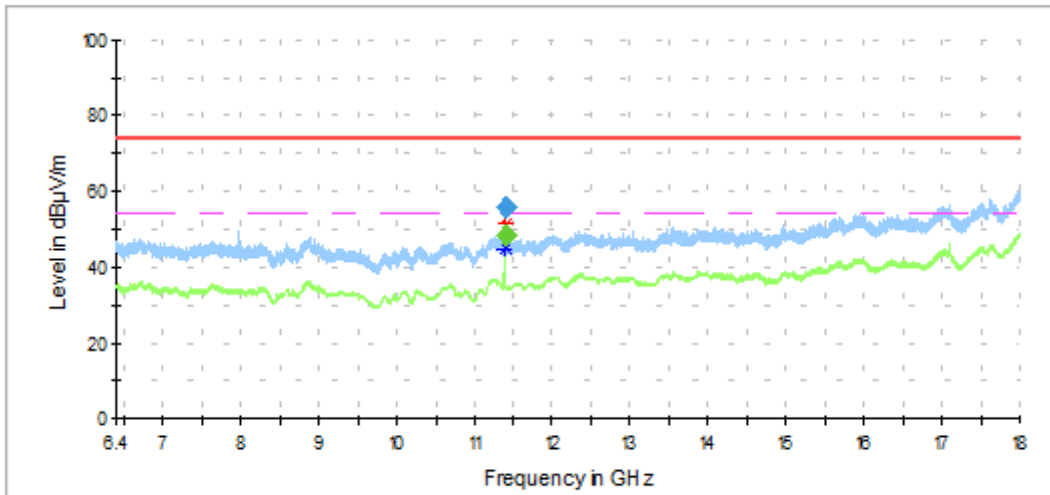
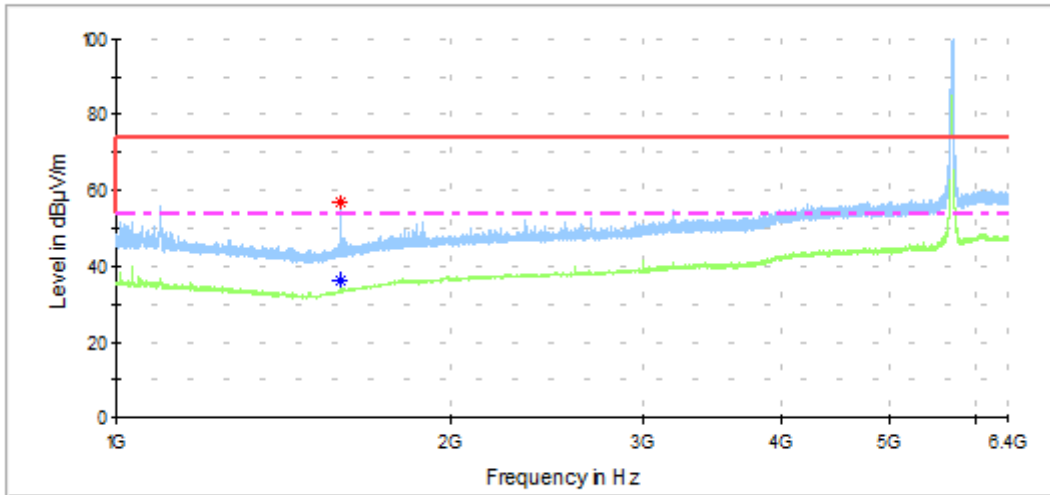

— Peak measurements     
 — Avg measurements     
 — Limit FCC Peak     
 - - - Limit FCC Avg

Frequency	MaxPeak	Avg	Limit	Margin
MHz	dBuV/m	dBuV/m	dBuV/m	dB
1593.3	---	36.4	54.0	17.6
1595.2	57.0	---	74.0	17.0
11399.6	55.7	---	74.0	18.3
11400.0	---	48.7	54.0	5.3

**1 GHz – 18 GHz, 802.11a, 6Mbps, Chain B**

**Radiated Spurious – CH100**

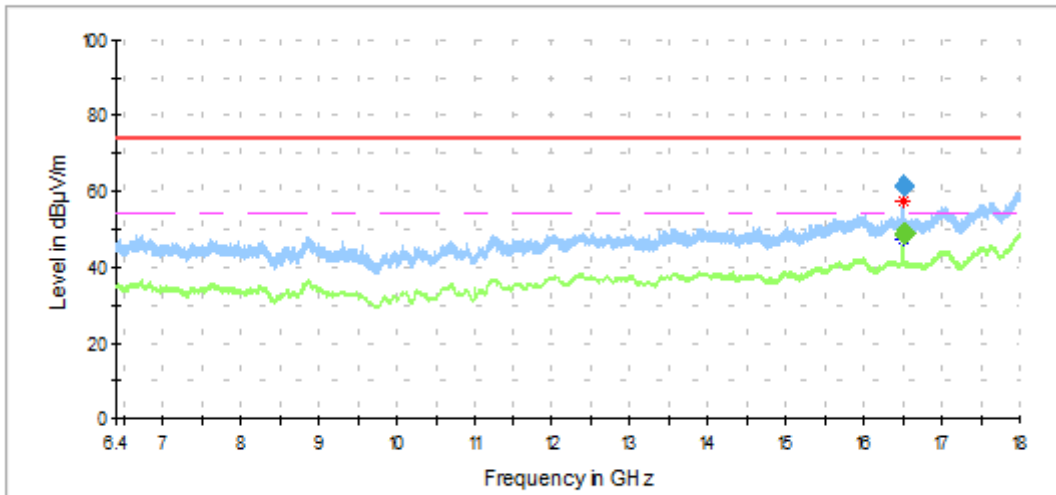
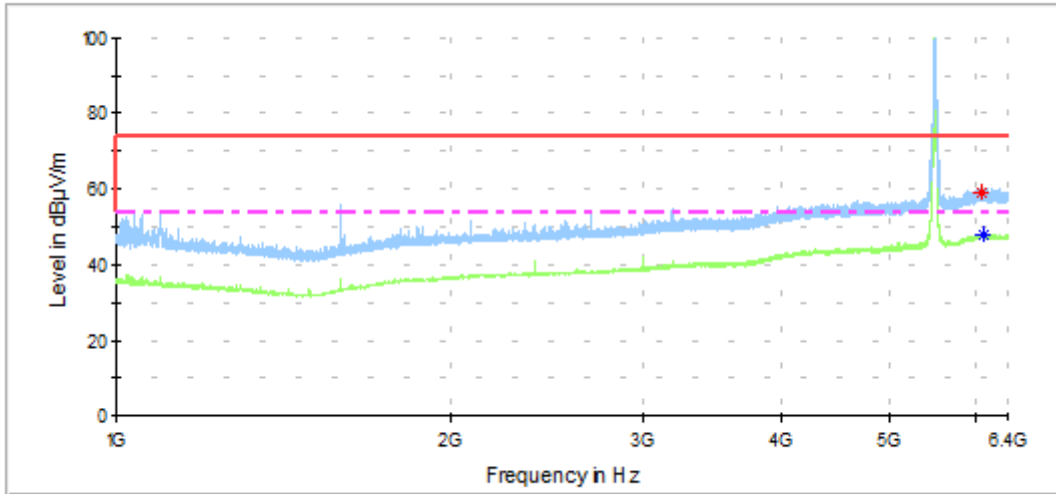

— Peak measurements      — Avg measurements      — Limit FCC Peak      - - - Limit FCC Avg

Frequency	MaxPeak	Avg	Limit	Margin
MHz	dBuV/m	dBuV/m	dBuV/m	dB
6063.2	58.8	---	74.0	15.2
6081.6	---	47.9	54.0	6.1
16501.8	---	49.1	54.0	4.9
16506.7	61.3	---	74.0	12.7

### Radiated Spurious – CH120

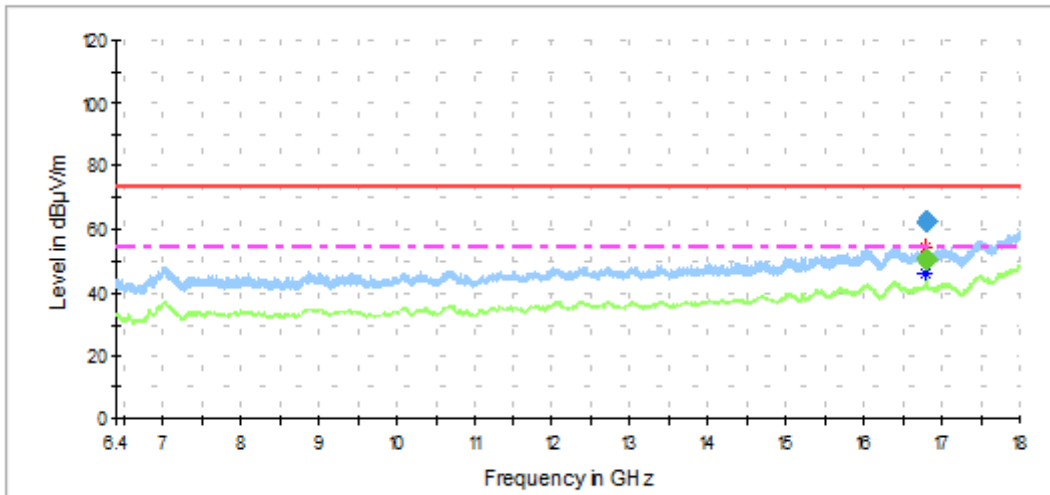
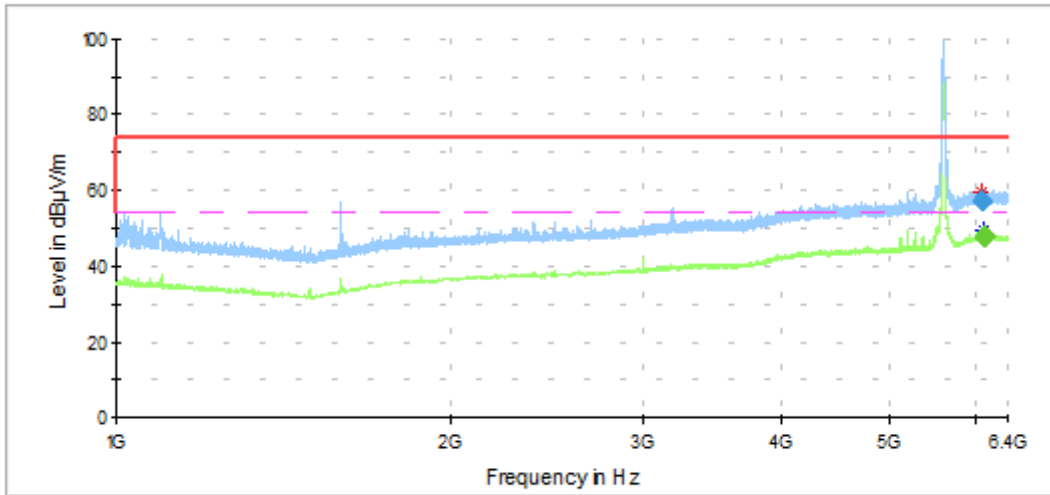

— Peak measurements     
 — Avg measurements     
 — Limit FCC Peak     
 - - - Limit FCC Avg

Frequency	MaxPeak	Avg	Limit	Margin
MHz	dBuV/m	dBuV/m	dBuV/m	dB
6072.3	57.5	---	74.0	16.5
6076.5	---	47.8	54.0	6.2
16795.5	62.7	---	74.0	11.3
16795.5	---	50.7	54.0	3.3

### Radiated Spurious – CH140

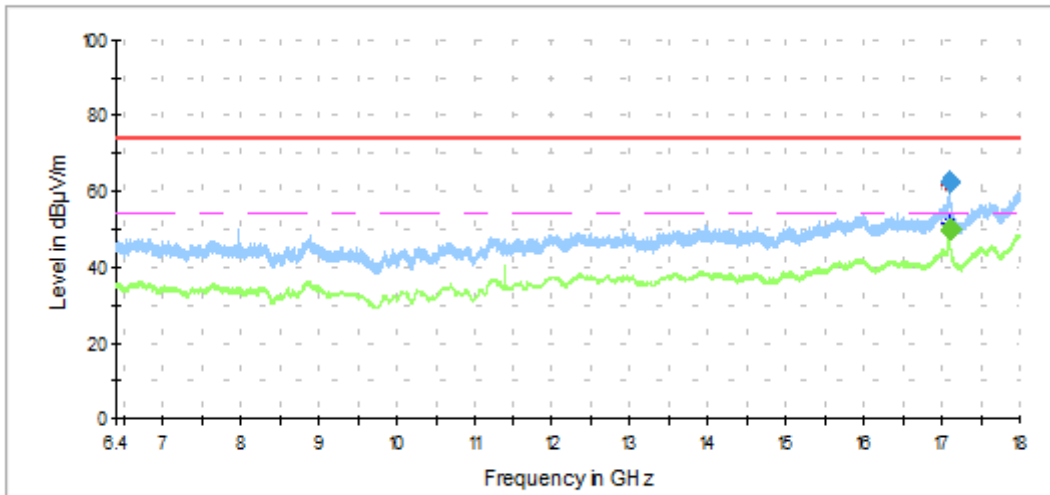
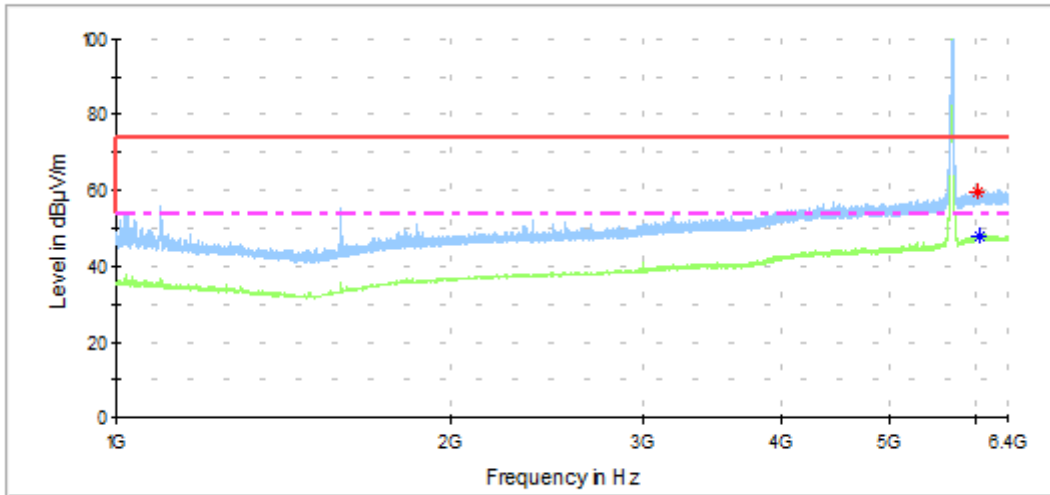

— Peak measurements     
 — Avg measurements     
 — Limit FCC Peak     
 - - - Limit FCC Avg

Frequency	MaxPeak	Avg	Limit	Margin
MHz	dBuV/m	dBuV/m	dBuV/m	dB
6022.7	59.4	---	74.0	14.6
6038.7	---	47.8	54.0	6.2
17099.2	---	50.2	54.0	3.8
17100.6	62.8	---	74.0	11.2

**1 GHz – 18 GHz, 802.11n20, HT0, Chain A**

**Radiated Spurious – CH100**

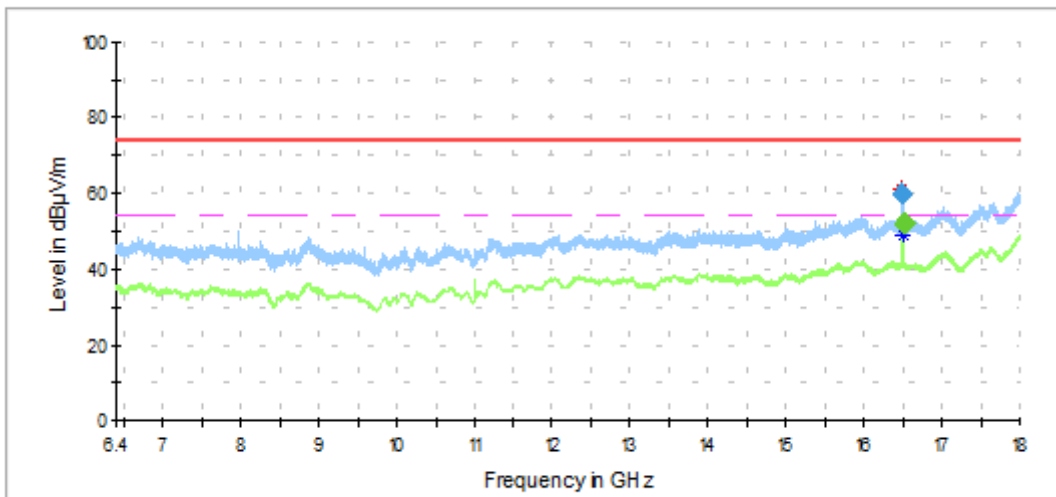
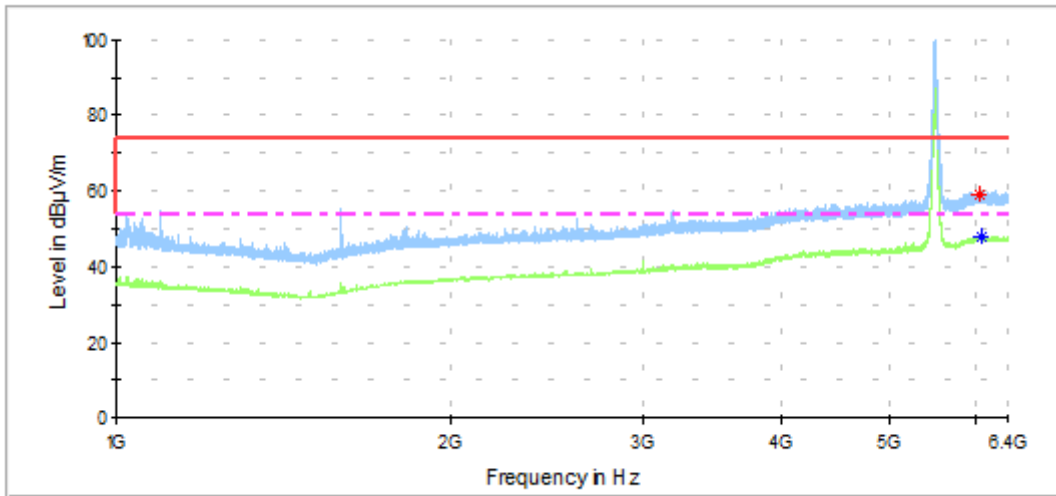

— Peak measurements      — Avg measurements      — Limit FCC Peak      - - - Limit FCC Avg

Frequency	MaxPeak	Avg	Limit	Margin
MHz	dBuV/m	dBuV/m	dBuV/m	dB
6038.4	59.1	---	74.0	14.9
6064.0	---	48.0	54.0	6.0
16497.8	60.2	---	74.0	13.8
16502.3	---	52.2	54.0	1.8



### Radiated Spurious – CH120

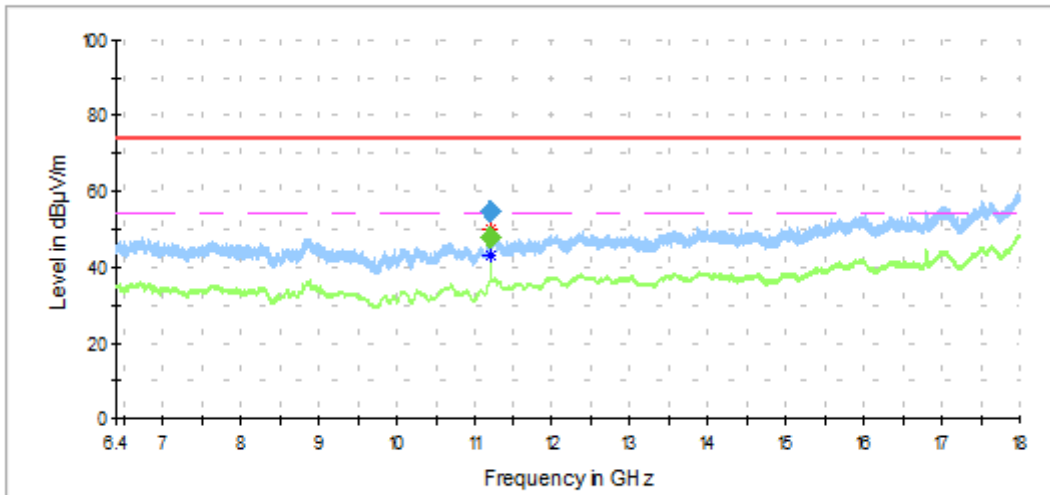
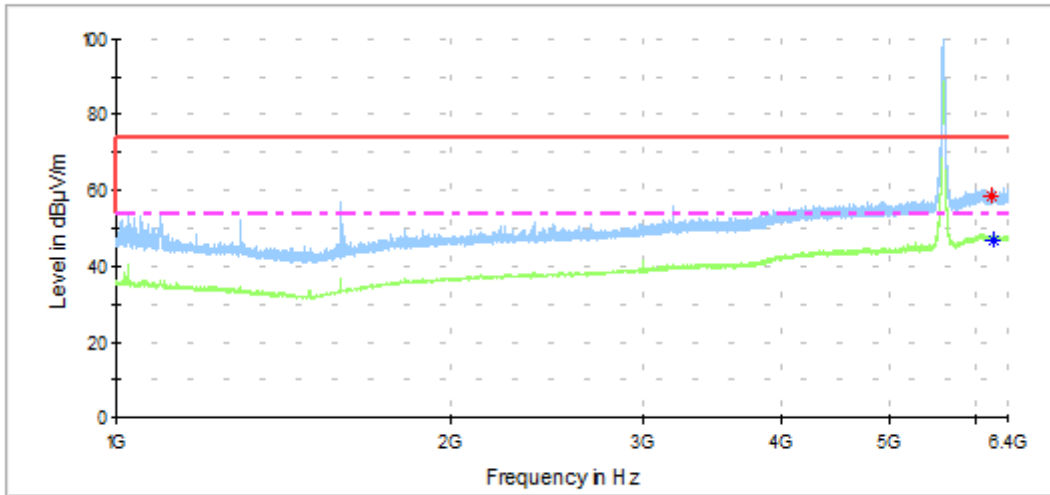

— Peak measurements     
 — Avg measurements     
 — Limit FCC Peak     
 - - - Limit FCC Avg

Frequency	MaxPeak	Avg	Limit	Margin
MHz	dBuV/m	dBuV/m	dBuV/m	dB
6185.7	58.3	---	74.0	15.7
6206.1	---	47.1	54.0	6.9
11199.7	---	47.6	54.0	6.4
11200.2	54.7	---	74.0	19.3

### Radiated Spurious – CH140

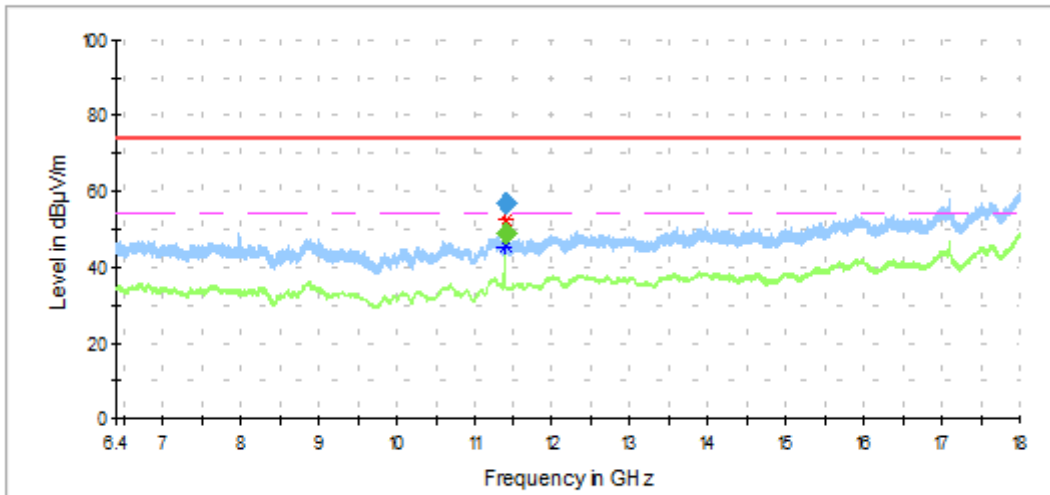
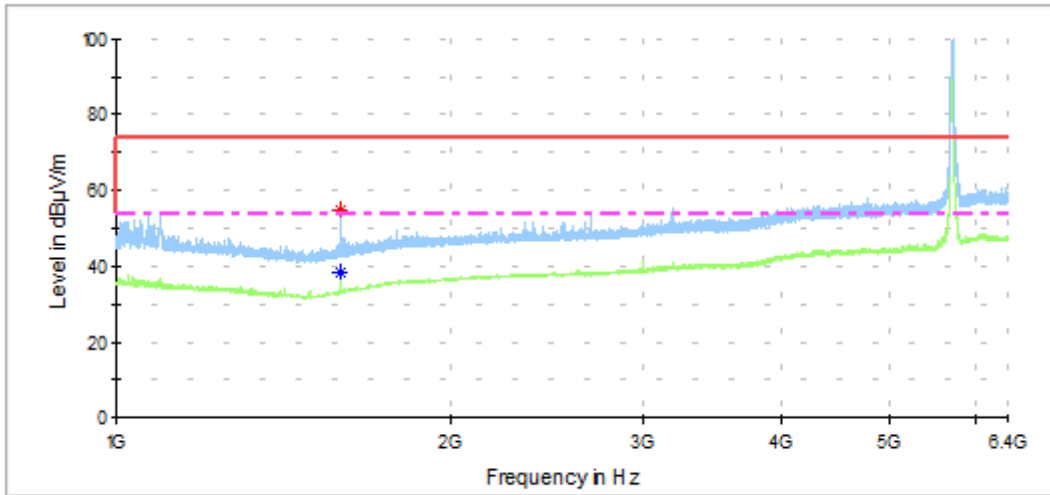

— Peak measurements     
 — Avg measurements     
 — Limit FCC Peak     
 - - - Limit FCC Avg

Frequency	MaxPeak	Avg	Limit	Margin
MHz	dBuV/m	dBuV/m	dBuV/m	dB
1594.2	54.8	---	74.0	19.2
1594.2	---	38.2	54.0	15.8
11400.0	---	48.7	54.0	5.3
11400.0	57.0	---	74.0	17.0

**1 GHz – 18 GHz, 802.11n20, HT0, Chain B**

**Radiated Spurious – CH100**

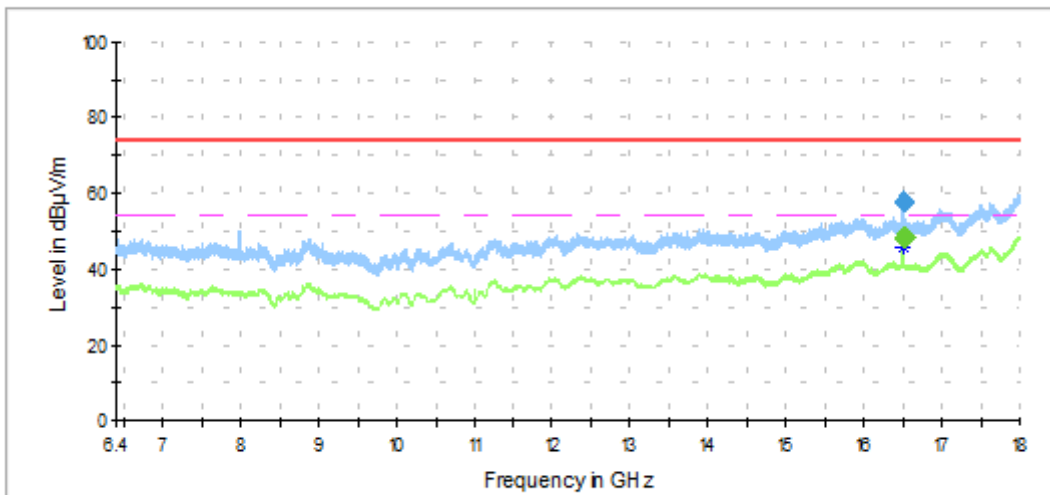
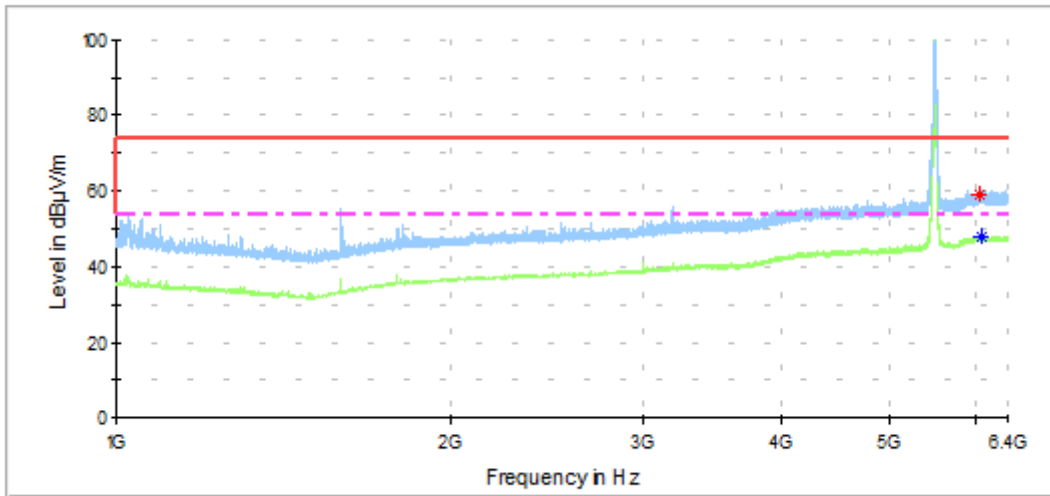

— Peak measurements     
 — Avg measurements     
 — Limit FCC Peak     
 - - - Limit FCC Avg

Frequency	MaxPeak	Avg	Limit	Margin
MHz	dBuV/m	dBuV/m	dBuV/m	dB
6030.1	58.8	---	74.0	15.2
6055.6	---	48.1	54.0	5.9
16502.3	---	48.7	54.0	5.3
16511.6	58.1	---	74.0	15.9

### Radiated Spurious – CH120

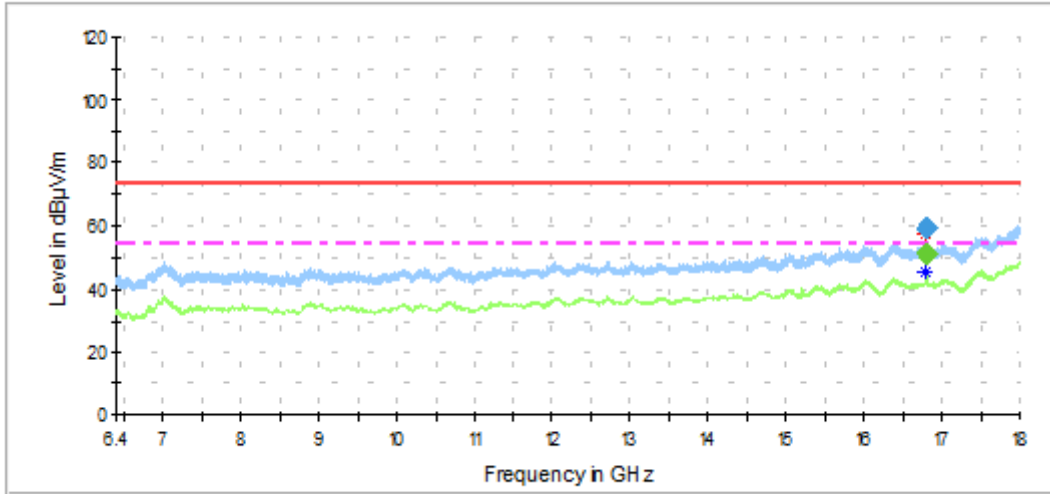
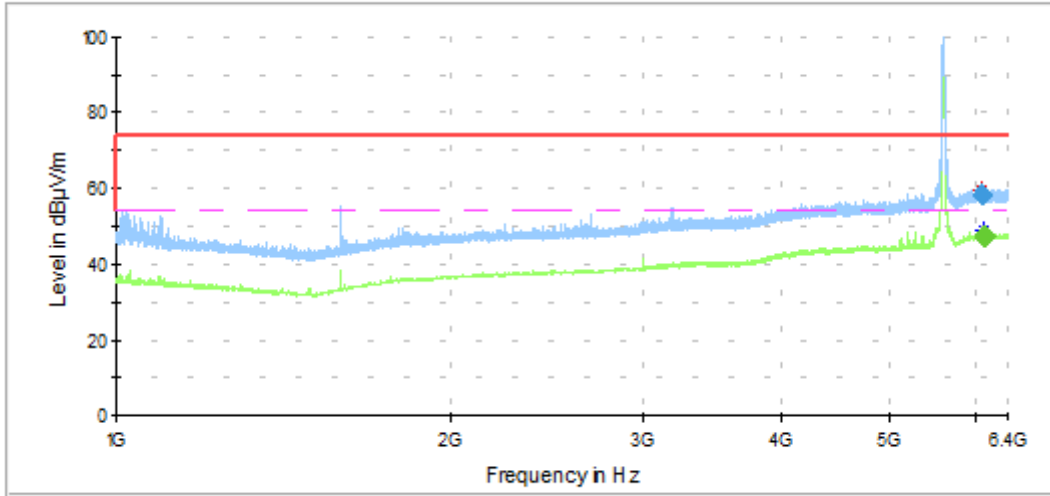

— Peak measurements     
 — Avg measurements     
 — Limit FCC Peak     
 - - - Limit FCC Avg

Frequency	MaxPeak	Avg	Limit	Margin
MHz	dBuV/m	dBuV/m	dBuV/m	dB
6075.0	59.6	---	74.0	14.4
6084.1	---	48.8	54.0	5.2
16795.5	59.7	---	74.0	14.3
16797.5	---	50.9	54.0	3.1

### Radiated Spurious – CH140

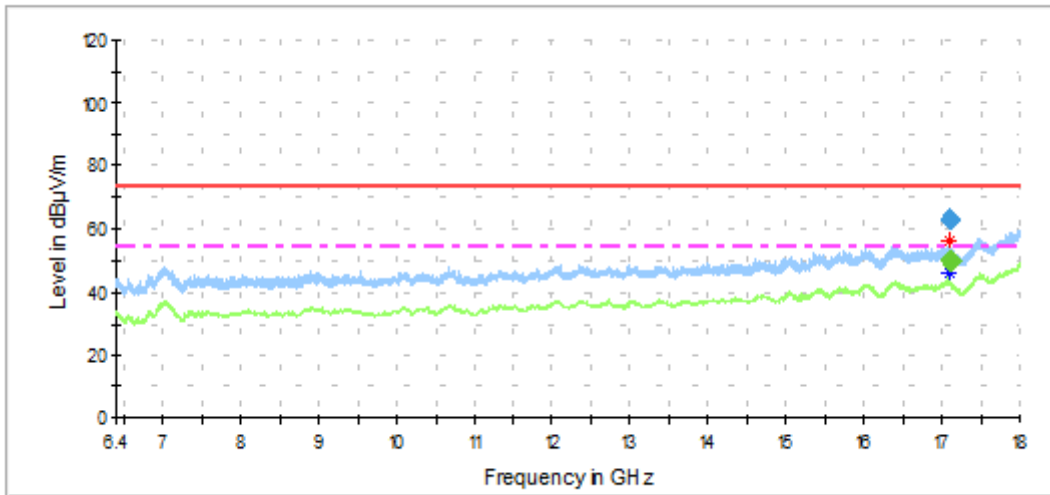
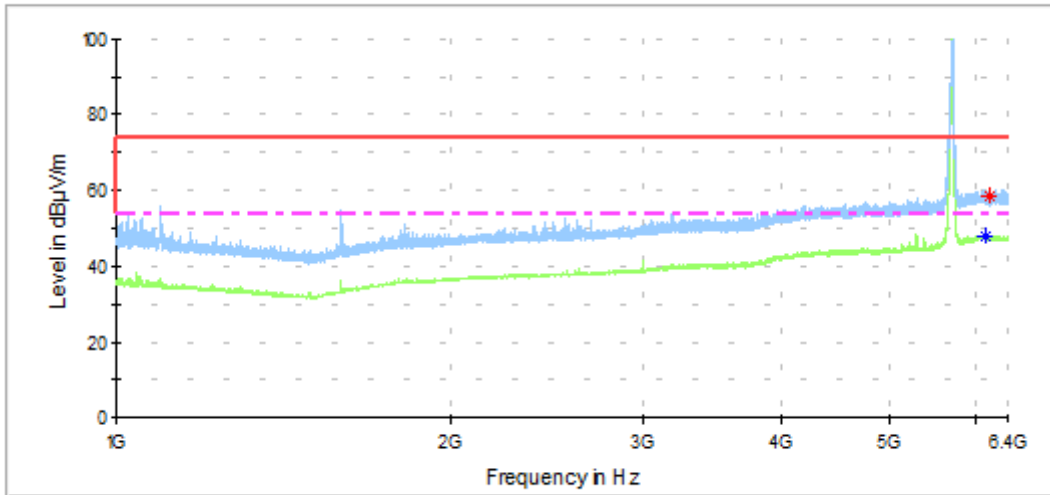

— Peak measurements     
 — Avg measurements     
 — Limit FCC Peak     
 - - - Limit FCC Avg

Frequency	MaxPeak	Avg	Limit	Margin
MHz	dBuV/m	dBuV/m	dBuV/m	dB
6122.6	---	47.7	54.0	6.3
6161.9	58.3	---	74.0	15.7
17101.5	62.9	---	74.0	11.1
17102.5	---	50.1	54.0	3.9

**1 GHz – 18 GHz, 802.11n20, HT8, Chain A+B**

**Radiated Spurious – CH100**

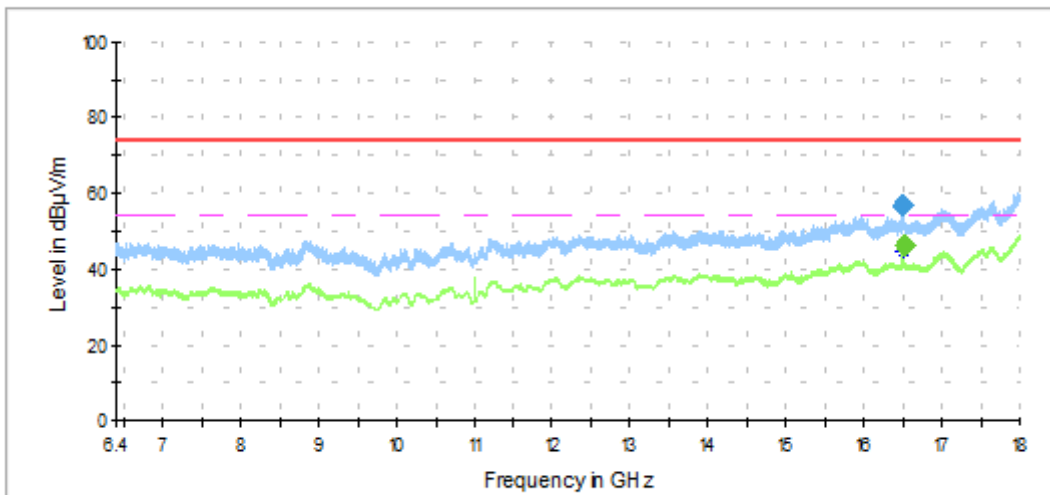
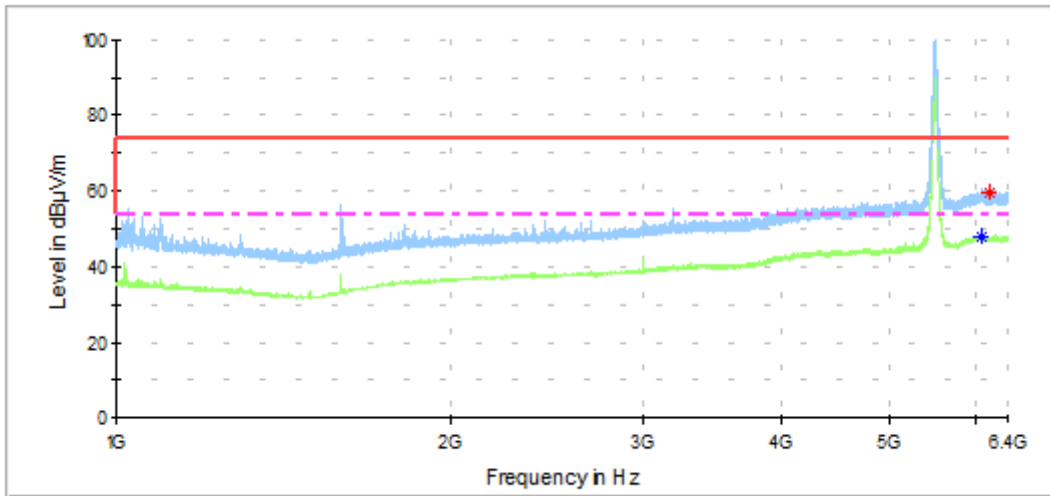

— Peak measurements      — Avg measurements      — Limit FCC Peak      - - - Limit FCC Avg

Frequency	MaxPeak	Avg	Limit	Margin
MHz	dBuV/m	dBuV/m	dBuV/m	dB
6064.0	---	48.0	54.0	6.0
6161.2	59.2	---	74.0	14.8
16496.5	56.7	---	74.0	17.3
16505.4	---	46.4	54.0	7.6

**1 GHz – 18 GHz, 802.11n40, HT0, Chain A**

**Radiated Spurious – CH102F**

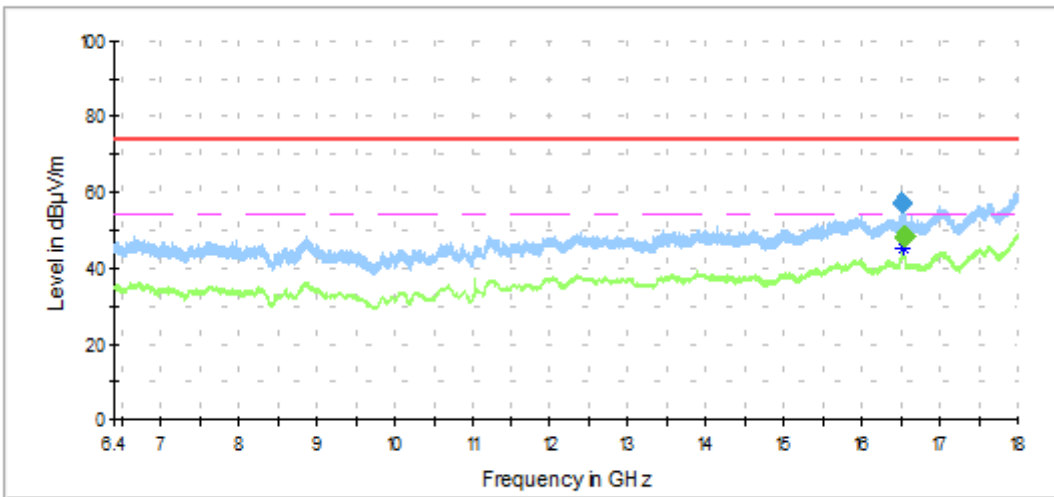
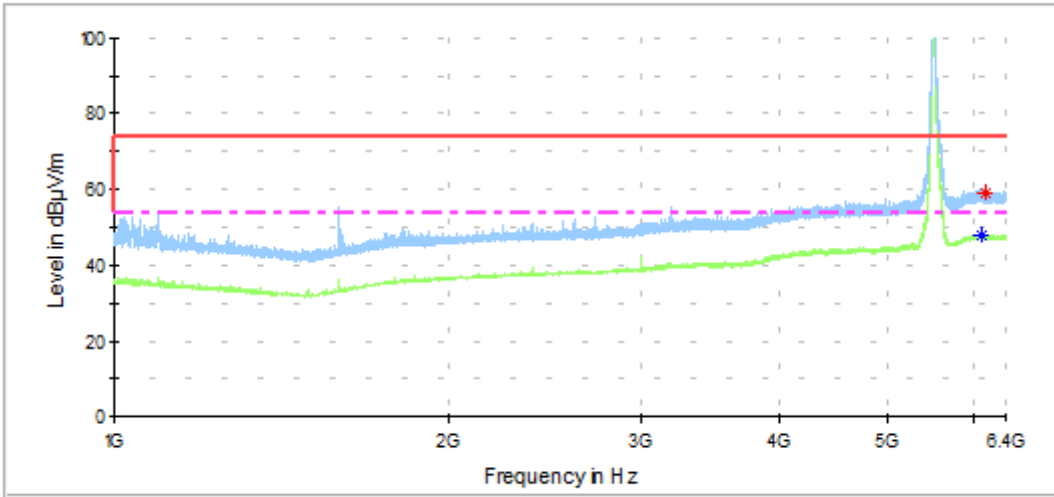

— Peak measurements      — Avg measurements      — Limit FCC Peak      - - - Limit FCC Avg

Frequency	MaxPeak	Avg	Limit	Margin
MHz	dBuV/m	dBuV/m	dBuV/m	dB
6100.3	---	47.7	54.0	6.3
6132.0	59.2	---	74.0	14.8
16515.2	57.2	---	74.0	16.8
16527.2	---	48.4	54.0	5.6

### Radiated Spurious – CH118F

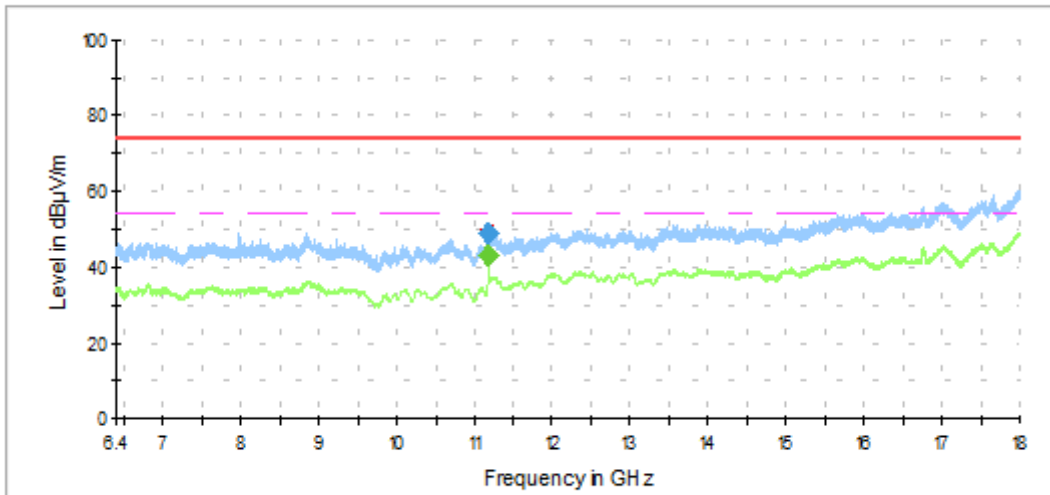
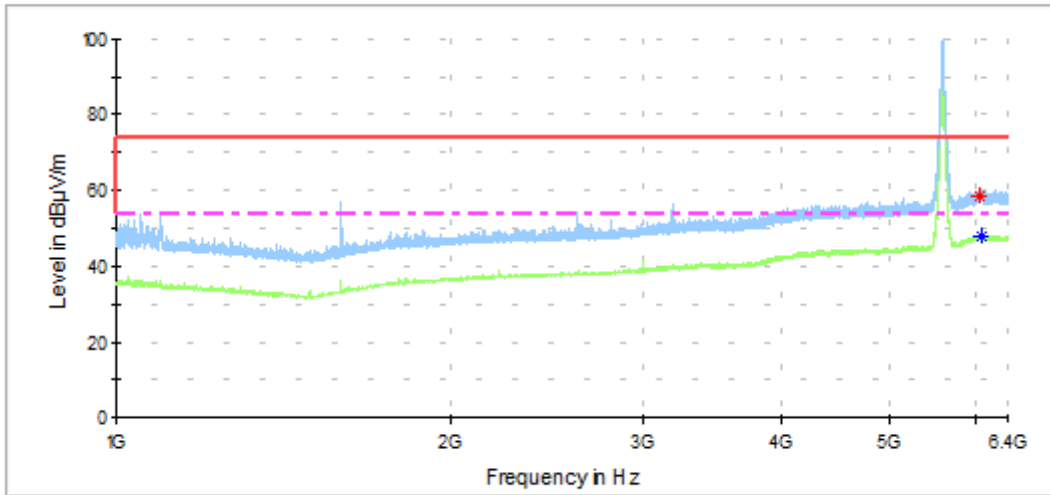

— Peak measurements     
 — Avg measurements     
 — Limit FCC Peak     
 - - - Limit FCC Avg

Frequency	MaxPeak	Avg	Limit	Margin
MHz	dBuV/m	dBuV/m	dBuV/m	dB
6044.6	58.5	---	74.0	15.5
6055.4	---	47.6	54.0	6.4
11179.2	48.8	---	74.0	25.2
11179.6	---	43.3	54.0	10.7



### Radiated Spurious – CH134F

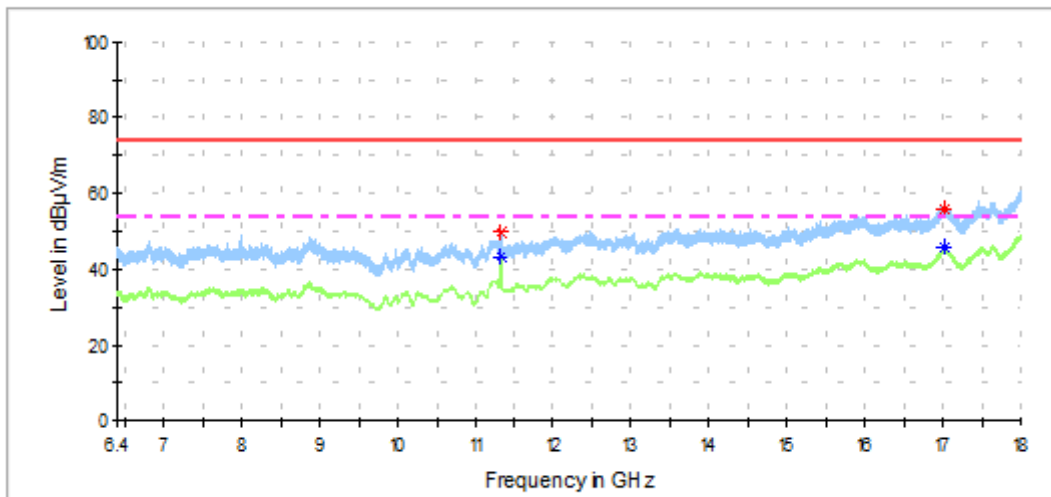
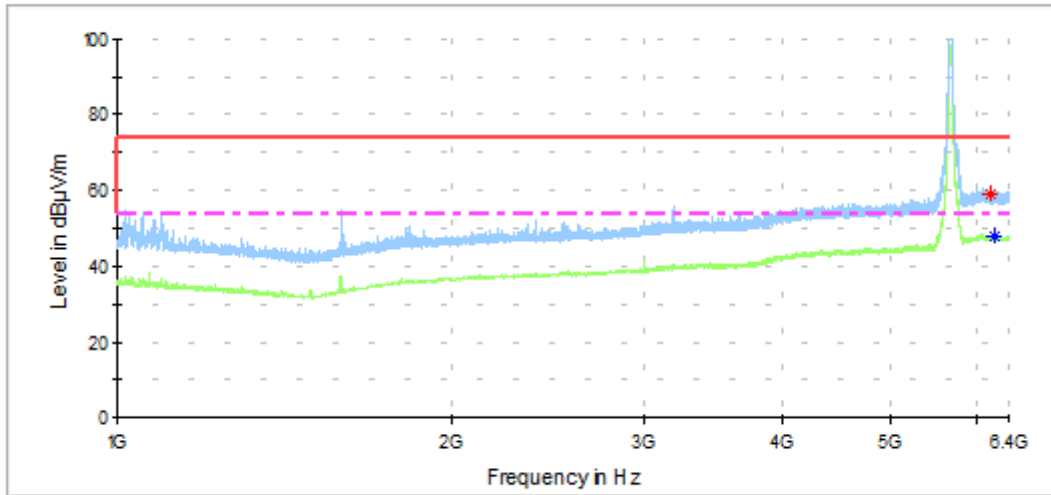

— Peak measurements     
 — Avg measurements     
 — Limit FCC Peak     
 - - - Limit FCC Avg

Frequency	MaxPeak	Avg	Limit	Margin
MHz	dBuV/m	dBuV/m	dBuV/m	dB
6152.8	59.1	---	74.0	14.9
6203.4	---	47.7	54.0	6.3
11339.8	---	43.2	54.0	10.8
11340.3	50.2	---	74.0	23.8
17012.7	---	45.6	54.0	8.4
17031.8	56.0	---	74.0	18.0

**1 GHz – 18 GHz, 802.11n40, HT0, Chain B**

**Radiated Spurious – CH102F**

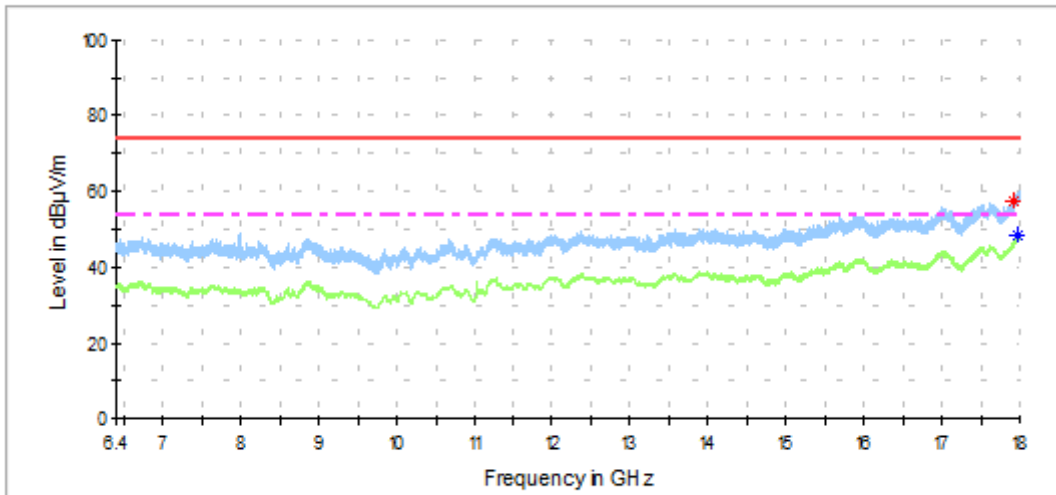
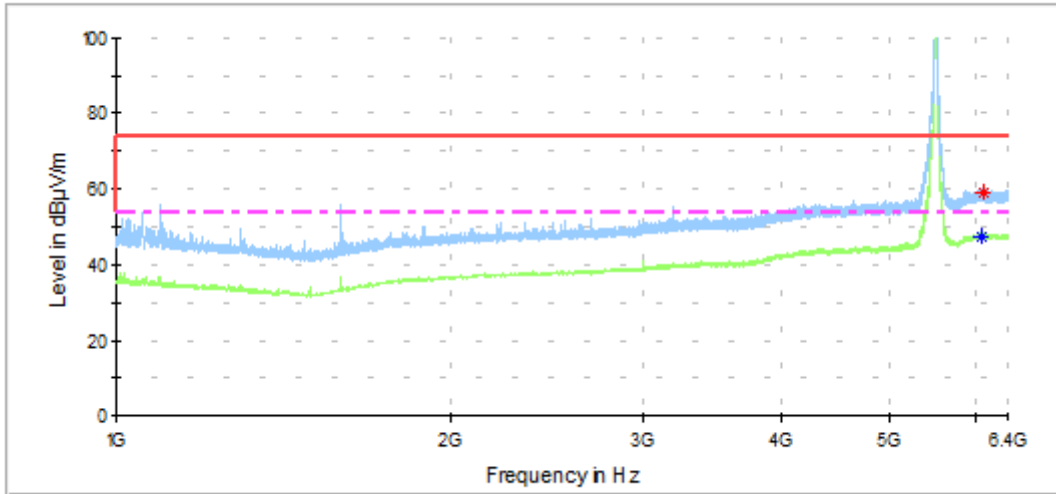

— Peak measurements      — Avg measurements      — Limit FCC Peak      - - - Limit FCC Avg

Frequency	MaxPeak	Avg	Limit	Margin
MHz	dBuV/m	dBuV/m	dBuV/m	dB
6072.3	---	47.5	54.0	6.5
6079.2	58.8	---	74.0	15.2
17934.9	57.6	---	74.0	16.4
17979.0	---	48.6	54.0	5.4

### Radiated Spurious – CH118F

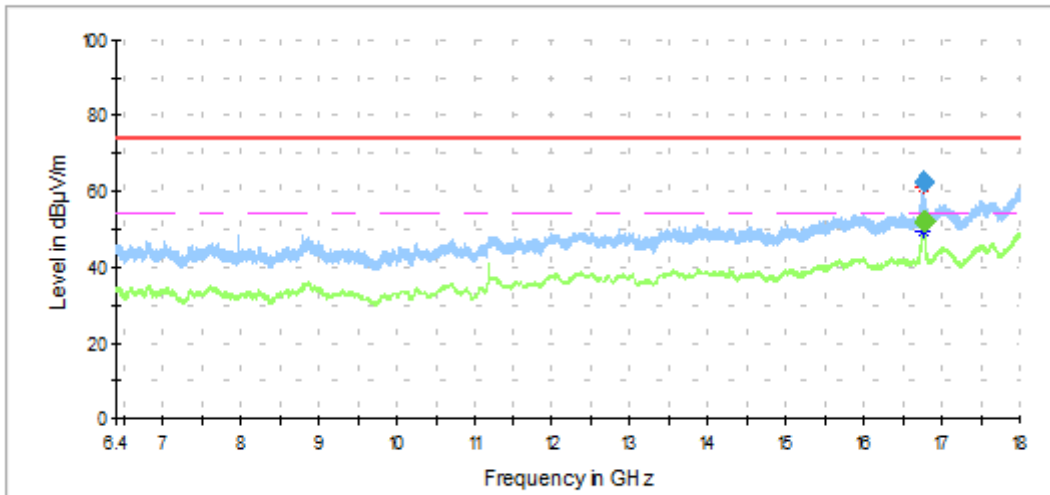
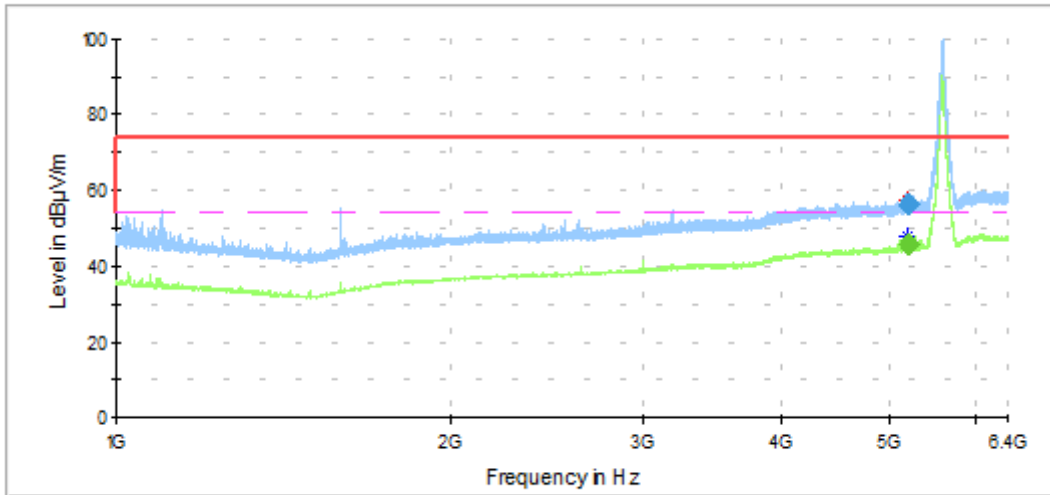

— Peak measurements     
 — Avg measurements     
 — Limit FCC Peak     
 - - - Limit FCC Avg

Frequency	MaxPeak	Avg	Limit	Margin
MHz	dBuV/m	dBuV/m	dBuV/m	dB
5192.4	57.6	---	74.0	16.4
5199.5	---	47.7	54.0	6.3
16761.9	---	52.3	54.0	1.7
16761.9	62.5	---	74.0	11.5

### Radiated Spurious – CH134F

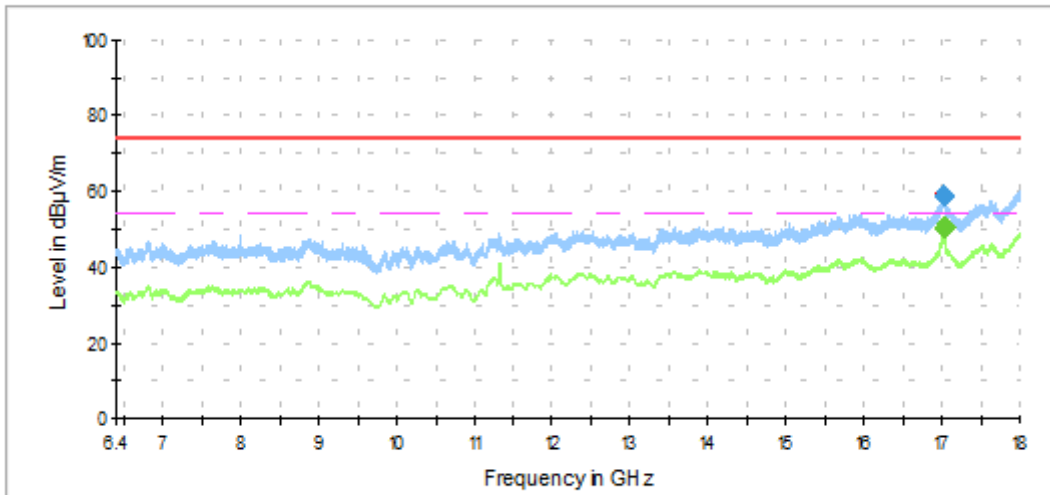
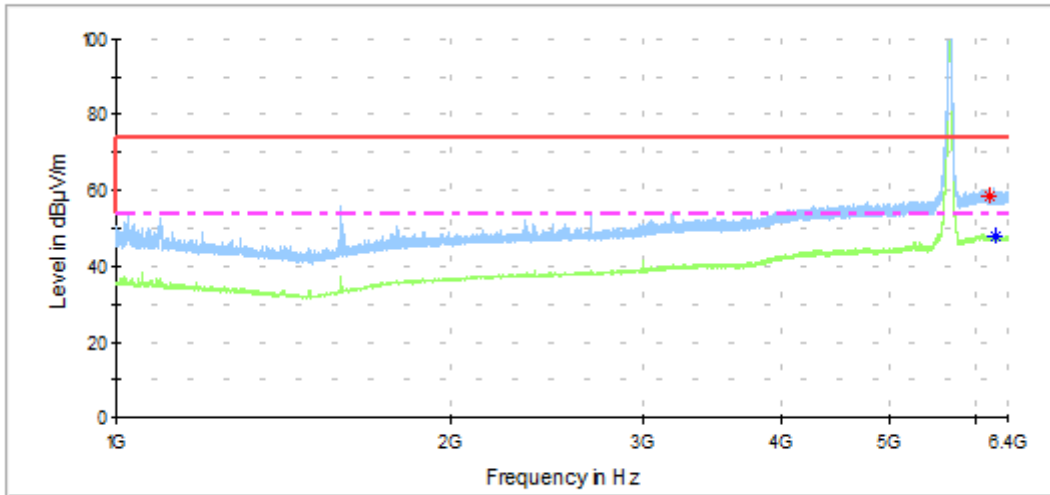

— Peak measurements     
 — Avg measurements     
 — Limit FCC Peak     
 - - - Limit FCC Avg

Frequency	MaxPeak	Avg	Limit	Margin
MHz	dBuV/m	dBuV/m	dBuV/m	dB
6176.6	58.4	---	74.0	15.6
6232.6	---	47.7	54.0	6.3
17019.8	---	50.5	54.0	3.5
17023.4	59.0	---	74.0	15.0

**1 GHz – 18 GHz, 802.11n40, HT8, Chain A+B**

**Radiated Spurious – CH118F**

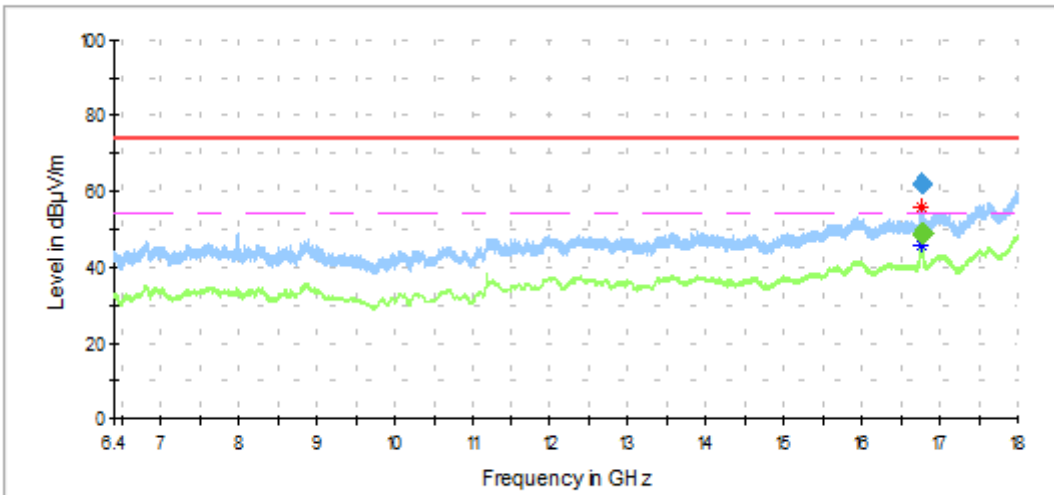
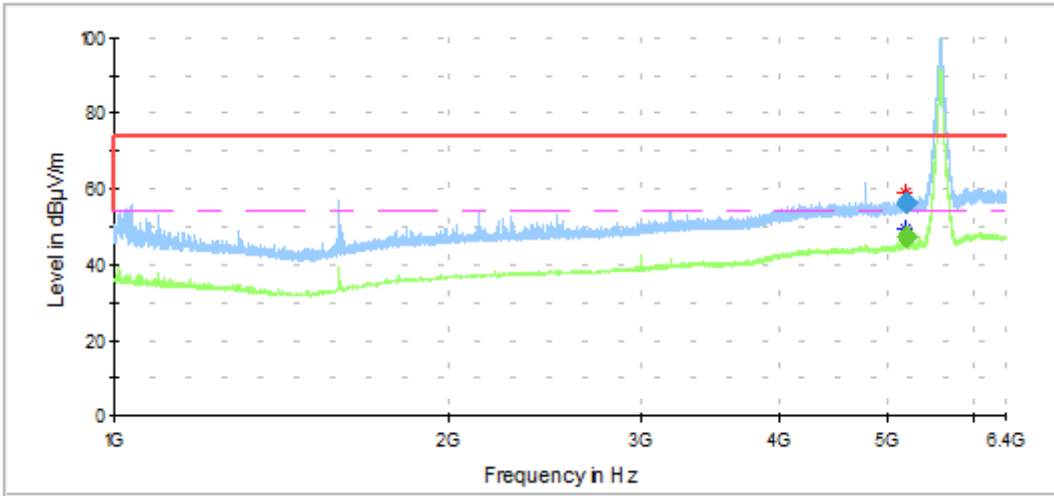

— Peak measurements      — Avg measurements      — Limit FCC Peak      - - - Limit FCC Avg

Frequency	MaxPeak	Avg	Limit	Margin
MHz	dBuV/m	dBuV/m	dBuV/m	dB
5196.3	58.9	---	74.0	15.1
5199.5	---	49.6	54.0	4.4
16768.2	62.0	---	74.0	12.0
16774.0	---	49.0	54.0	5.0

**1 GHz – 18 GHz, 802.11ac80, HT0, Chain A**

**Radiated Spurious – CH106ac80**

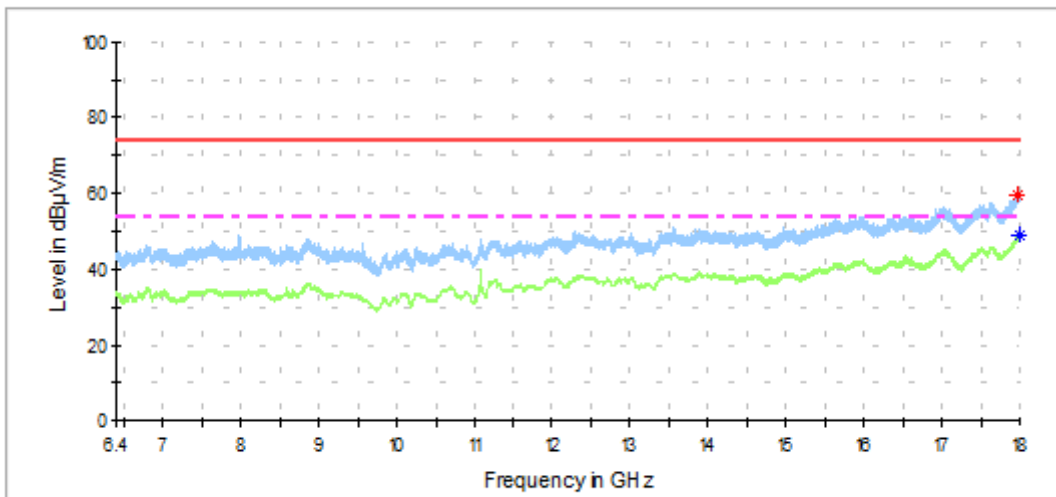
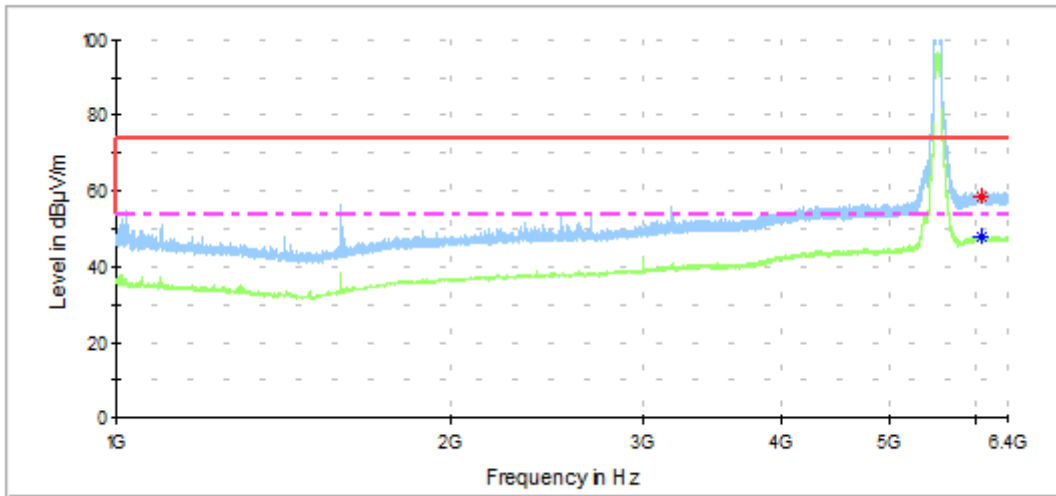

— Peak measurements      — Avg measurements      — Limit FCC Peak      - - - Limit FCC Avg

Frequency	MaxPeak	Avg	Limit	Margin
MHz	dBuV/m	dBuV/m	dBuV/m	dB
6054.2	58.6	---	74.0	15.4
6072.3	---	47.9	54.0	6.1
17972.3	59.2	---	74.0	14.8
17992.0	---	49.0	54.0	5.0

### Radiated Spurious – CH122ac80

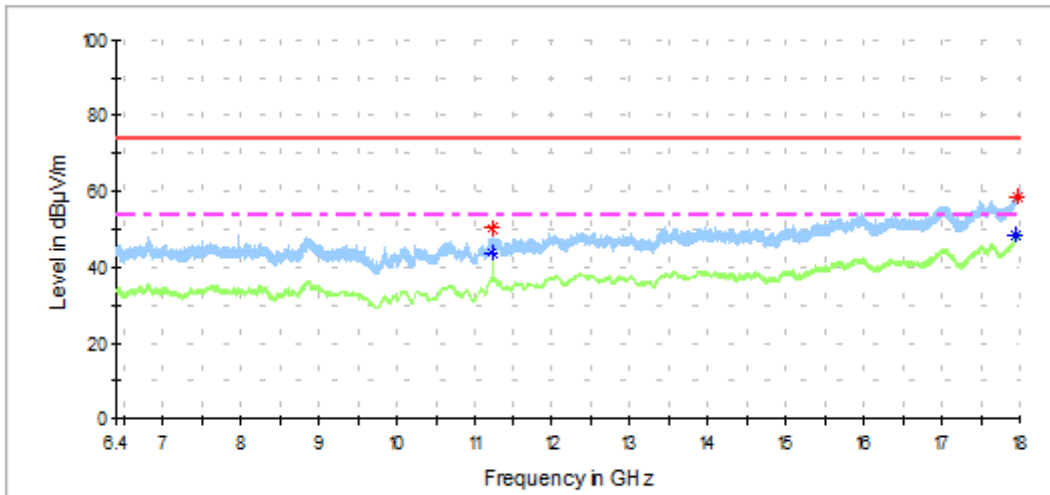
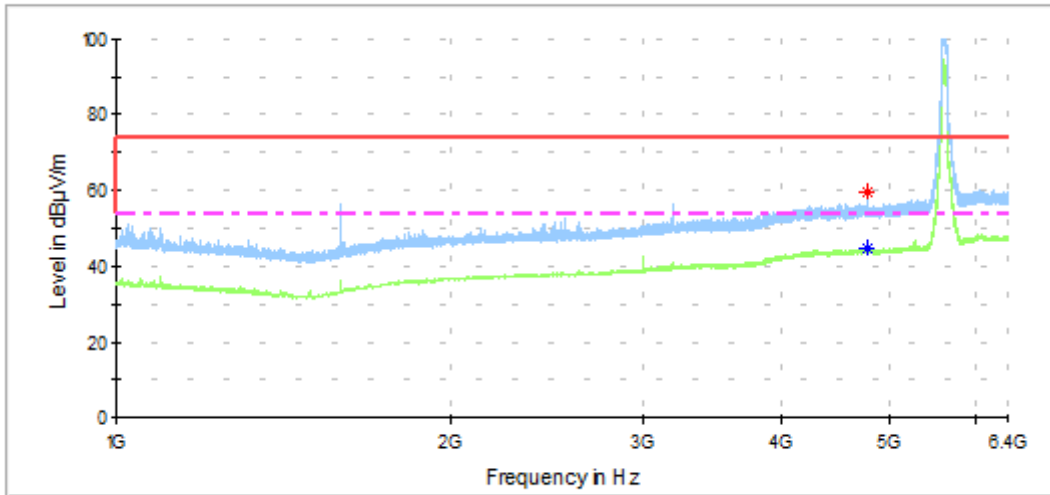

— Peak measurements     
 — Avg measurements     
 — Limit FCC Peak     
 - - - Limit FCC Avg

Frequency	MaxPeak	Avg	Limit	Margin
MHz	dBuV/m	dBuV/m	dBuV/m	dB
4782.5	59.5	---	74.0	14.5
4783.4	---	44.5	54.0	9.5
11219.8	---	43.8	54.0	10.2
11220.2	50.3	---	74.0	23.7
17959.0	---	48.4	54.0	5.6
17971.4	58.4	---	74.0	15.6

### Radiated Spurious – CH138ac80

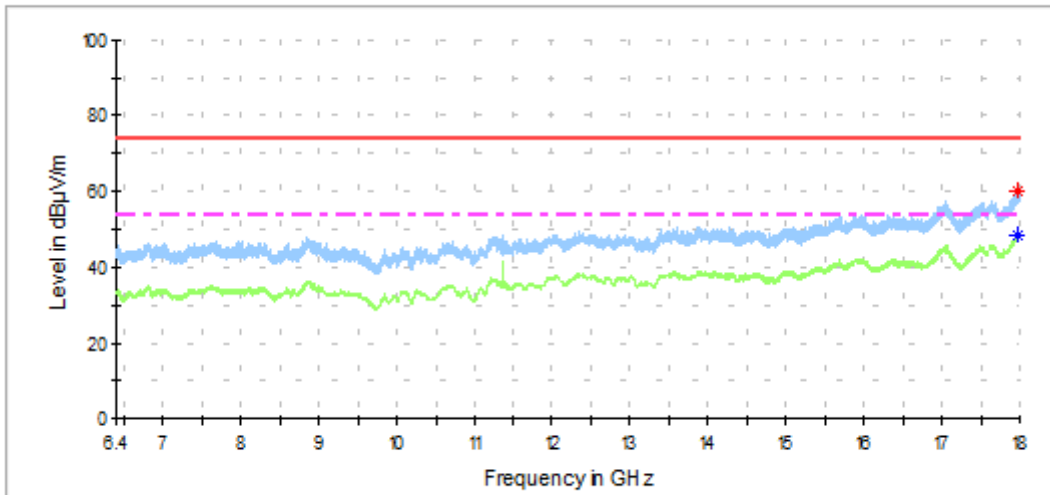
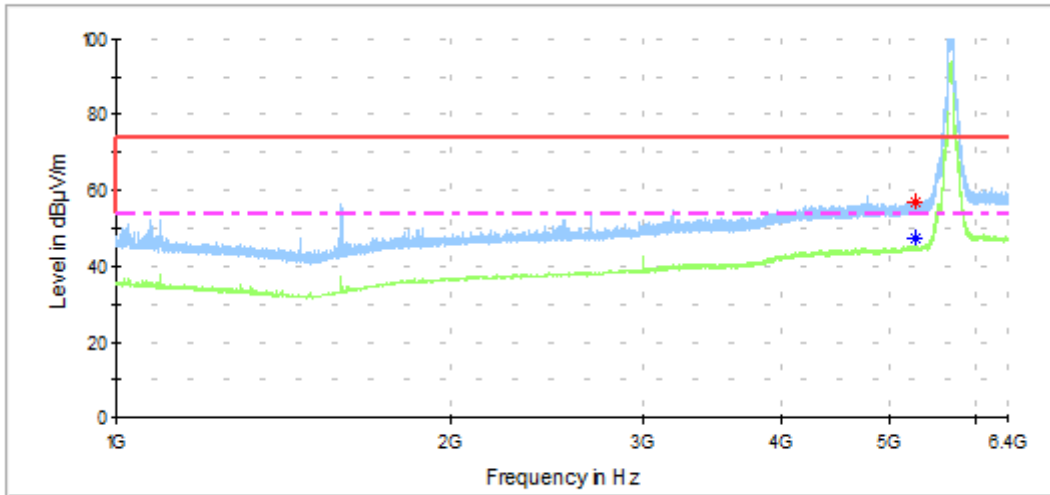

— Peak measurements     
 — Avg measurements     
 — Limit FCC Peak     
 - - - Limit FCC Avg

Frequency	MaxPeak	Avg	Limit	Margin
MHz	dBuV/m	dBuV/m	dBuV/m	dB
5277.8	56.8	---	74.0	17.2
5279.0	---	47.6	54.0	6.4
17979.0	---	48.3	54.0	5.7
17981.3	59.8	---	74.0	14.2



**1 GHz – 18 GHz, 802.11ac80, HT0, Chain B**

**Radiated Spurious – CH106ac80**

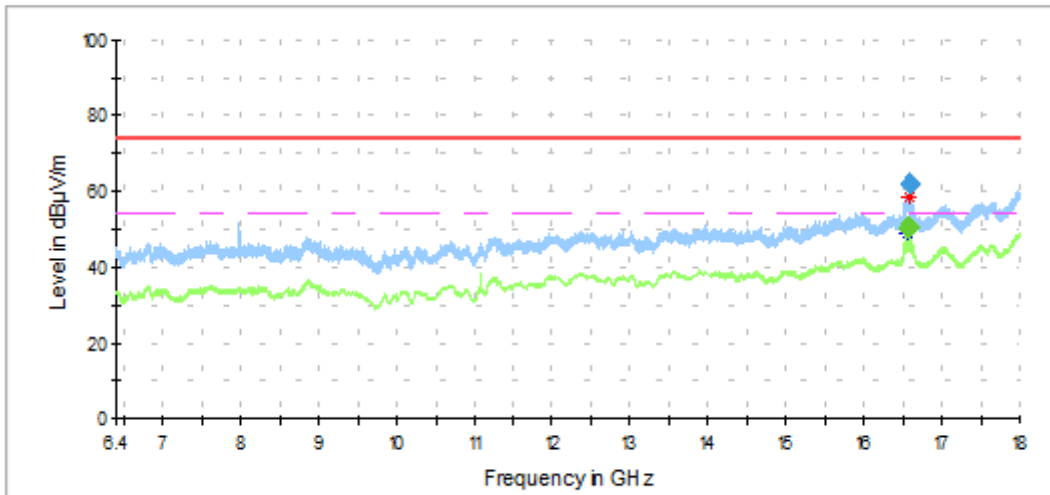
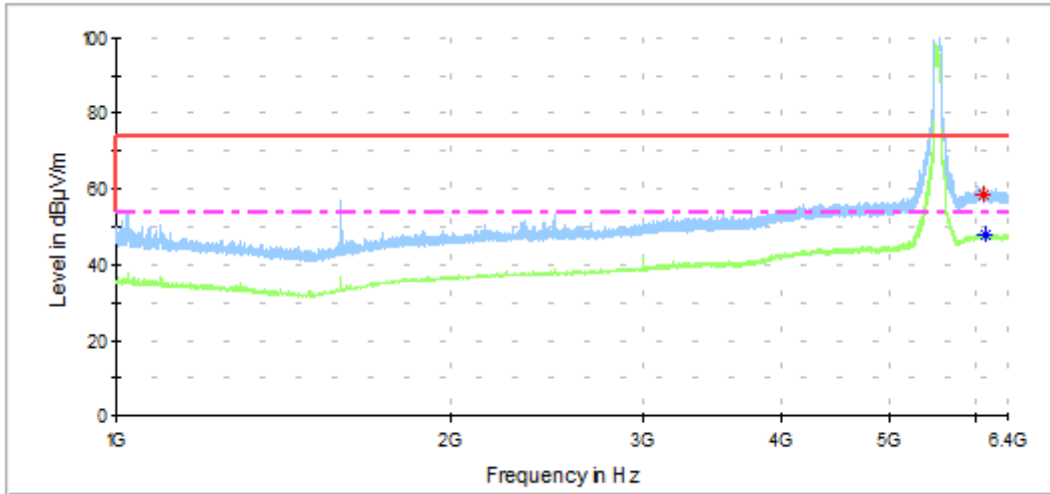

— Peak measurements      — Avg measurements      — Limit FCC Peak      - - - Limit FCC Avg

Frequency	MaxPeak	Avg	Limit	Margin
MHz	dBuV/m	dBuV/m	dBuV/m	dB
6091.2	58.2	---	74.0	15.8
6107.9	---	47.9	54.0	6.1
16575.4	---	50.7	54.0	3.3
16579.0	62.3	---	74.0	11.7

### Radiated Spurious – CH122ac80

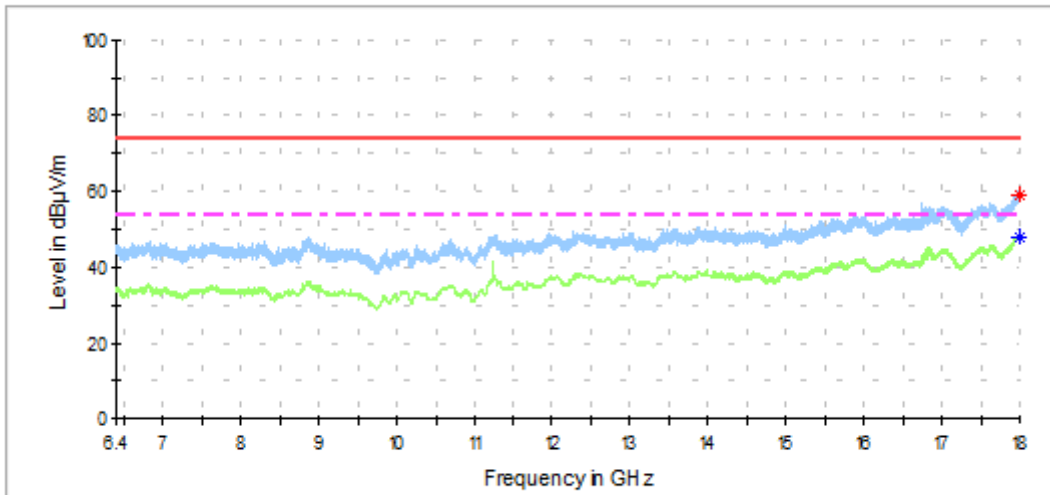
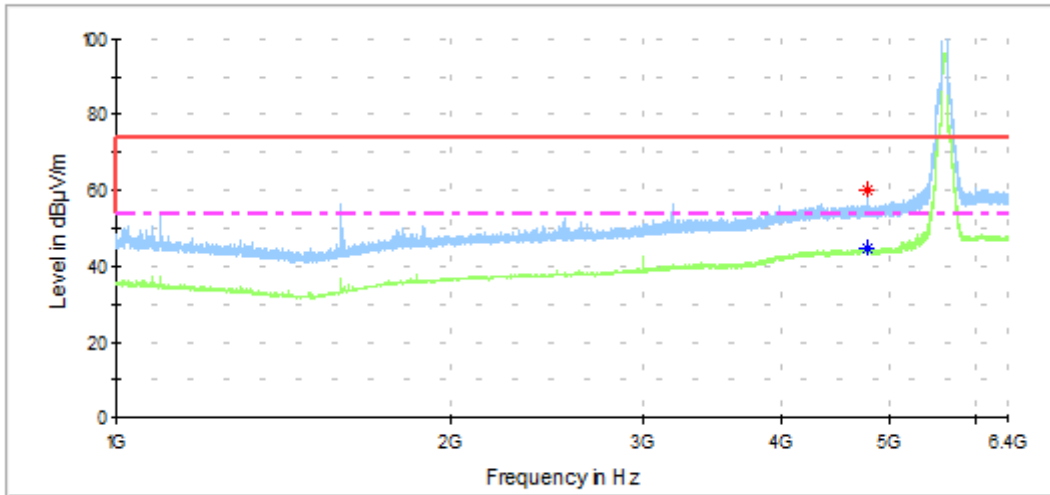

— Peak measurements     
 — Avg measurements     
 — Limit FCC Peak     
 - - - Limit FCC Avg

Frequency	MaxPeak	Avg	Limit	Margin
MHz	dBuV/m	dBuV/m	dBuV/m	dB
4789.1	---	44.7	54.0	9.3
4789.1	60.3	---	74.0	13.7
17987.5	---	48.0	54.0	6.0
17999.1	58.9	---	74.0	15.1

### Radiated Spurious – CH138ac80

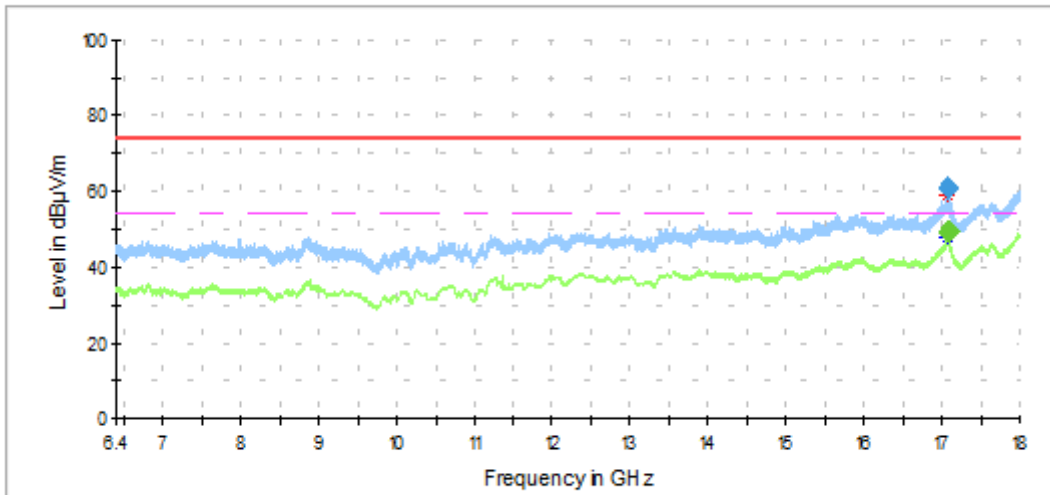
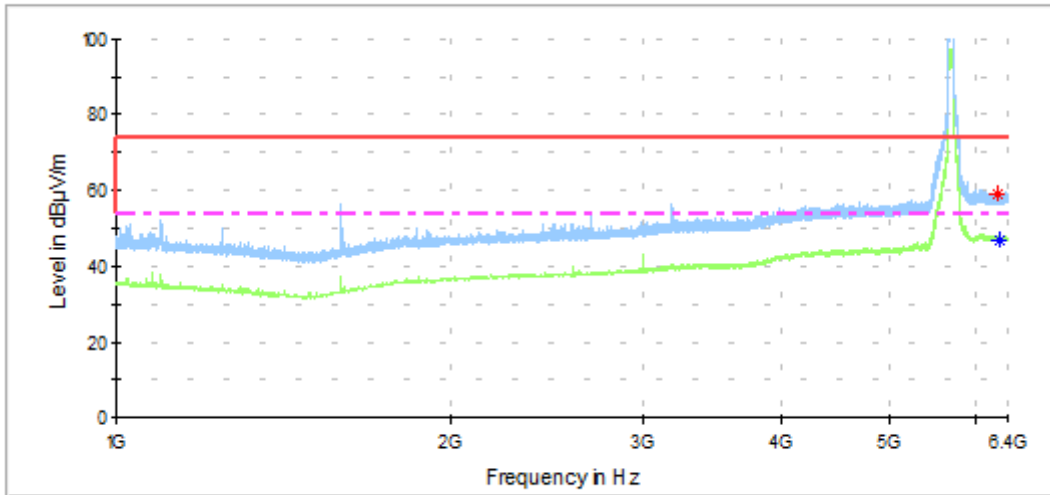

— Peak measurements     
 — Avg measurements     
 — Limit FCC Peak     
 - - - Limit FCC Avg

Frequency	MaxPeak	Avg	Limit	Margin
MHz	dBuV/m	dBuV/m	dBuV/m	dB
6270.2	59.0	---	74.0	15.0
6298.6	---	47.1	54.0	6.9
17979.0	---	48.3	54.0	5.7
17981.3	59.8	---	74.0	14.2

**1 GHz – 18 GHz, 802.11ac80, HT8, Chain A+B**

**Radiated Spurious – CH106ac80**

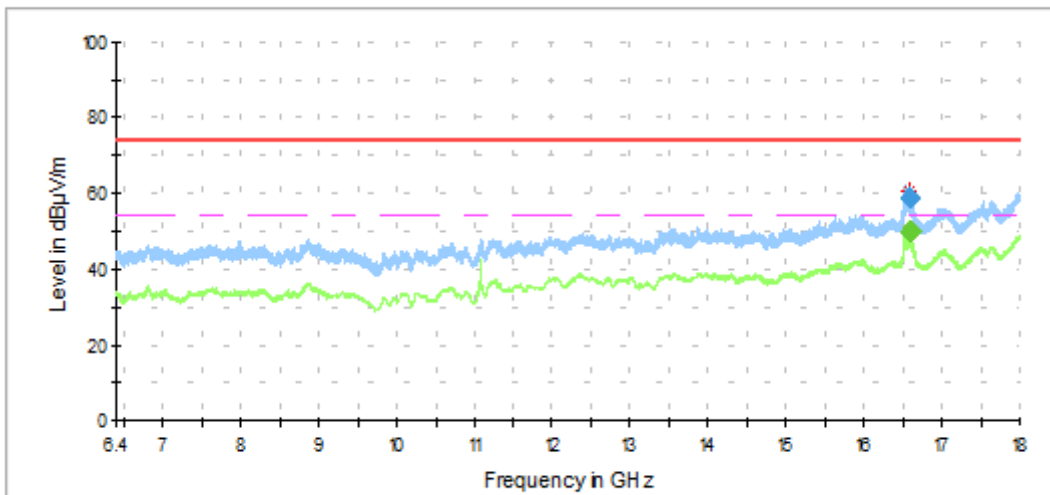
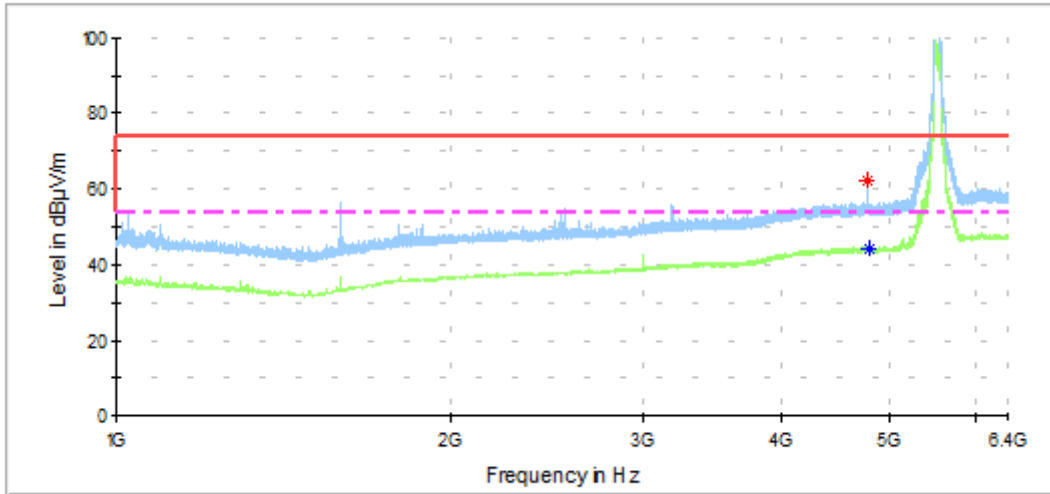

— Peak measurements      — Avg measurements      — Limit FCC Peak      - - - Limit FCC Avg

Frequency	MaxPeak	Avg	Limit	Margin
MHz	dBuV/m	dBuV/m	dBuV/m	dB
4787.6	62.1	---	74.0	11.9
4795.2	---	44.4	54.0	9.6
16585.7	---	49.9	54.0	4.1
16594.2	59.2	---	74.0	14.8

**18GHz – 40GHz**

**Radiated Spurious – All modes**

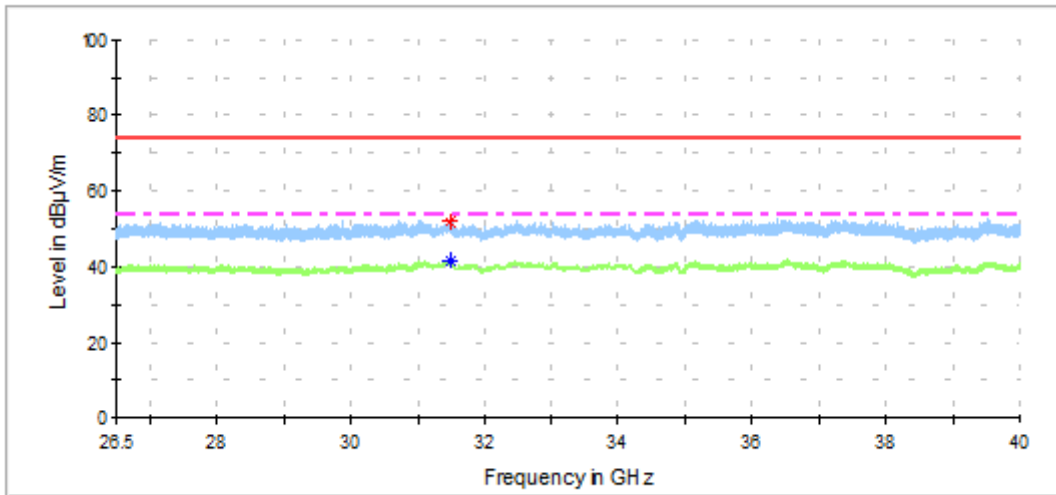
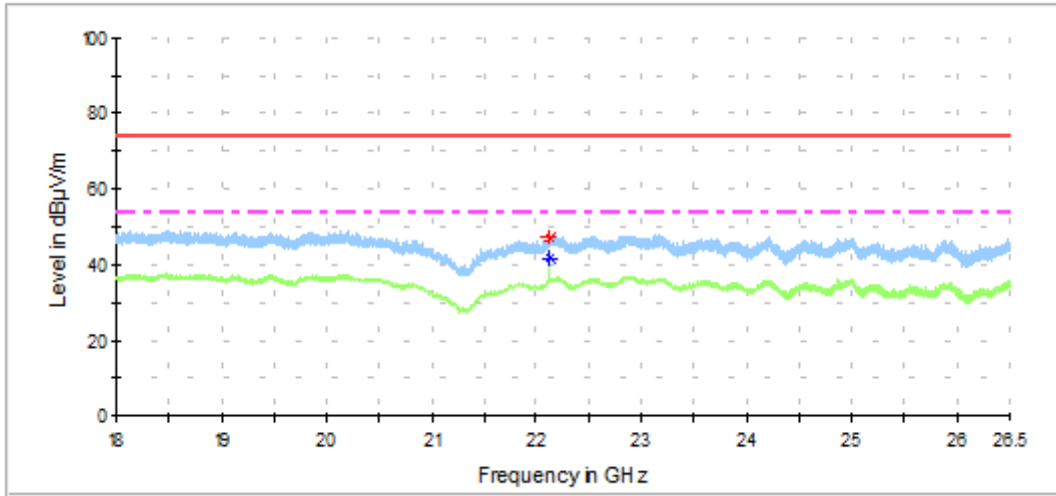

— Peak measurements     
 — Avg measurements     
 — Limit FCC Peak     
 - - - Limit FCC Avg

Frequency	MaxPeak	Avg	Limit	Margin
MHz	dBuV/m	dBuV/m	dBuV/m	dB
22119.7*	---	41.8	54.0	12.2
22120.1*	47.6	---	74.0	26.4
31475.2**	---	41.4	54.0	12.6
31487.3**	51.9	---	74.0	22.1

\*\* The spurious signals detected do not depend on either the operating channel or the modulation mode.

\* The spurious signals detected corresponds to the worst case among all channels presented above