



*EMC Test Report
Application for Grant of Equipment Authorization
Industry Canada RSS-Gen Issue 2 / RSS 210 Issue 7
FCC Part 15 Subpart C*

*Model: Intel® Centrino® Wireless-N 130 (models
130BNHMW and 130BNHU)*

IC CERTIFICATION #: 1000M-130BNH and 1000M-130BNHU
FCC ID: PD9130BNH and PD9130BNHU

APPLICANT: Intel Corporation
100 Center Point Circle Suite 200
Columbia, SC 29210

TEST SITE(S): Elliott Laboratories
41039 Boyce Road.
Fremont, CA. 94538-2435

IC SITE REGISTRATION #: 2845B-4, 2845B-5, 2845B-7

REPORT DATE: October 1, 2010

FINAL TEST DATES: September 8, 13, 14, and 15, 2010

AUTHORIZED SIGNATORY:

A handwritten signature in blue ink that reads "Mark Briggs".

Mark Briggs
Staff Engineer
Elliott Laboratories



Testing Cert #2016.01

Elliott Laboratories is accredited by the A2LA, certificate number 2016-01, to perform the test(s) listed in this report, except where noted otherwise. This report shall not be reproduced, except in its entirety, without the written approval of Elliott Laboratories

REVISION HISTORY

Rev#	Date	Comments	Modified By
-	10-01-2010	First release	

TABLE OF CONTENTS

REVISION HISTORY	2
TABLE OF CONTENTS	3
SCOPE.....	4
OBJECTIVE	4
STATEMENT OF COMPLIANCE.....	5
DEVIATIONS FROM THE STANDARDS.....	5
TEST RESULTS SUMMARY	6
FREQUENCY HOPPING SPREAD SPECTRUM (2400 – 2483.5 MHZ, LESS THAN 75 CHANNELS)	6
GENERAL REQUIREMENTS APPLICABLE TO ALL BANDS.....	6
ADDITIONAL MEASUREMENTS.....	7
MEASUREMENT UNCERTAINTIES.....	7
EQUIPMENT UNDER TEST (EUT) DETAILS.....	8
GENERAL.....	8
ANTENNA SYSTEM	8
ENCLOSURE.....	8
MODIFICATIONS.....	8
SUPPORT EQUIPMENT	9
EUT INTERFACE PORTS	9
EUT OPERATION	9
TEST SITE.....	10
GENERAL INFORMATION.....	10
CONDUCTED EMISSIONS CONSIDERATIONS	10
RADIATED EMISSIONS CONSIDERATIONS	10
MEASUREMENT INSTRUMENTATION	11
RECEIVER SYSTEM	11
INSTRUMENT CONTROL COMPUTER	11
LINE IMPEDANCE STABILIZATION NETWORK (LISN).....	11
FILTERS/ATTENUATORS	12
ANTENNAS.....	12
ANTENNA MAST AND EQUIPMENT TURNTABLE	12
INSTRUMENT CALIBRATION.....	12
TEST PROCEDURES	13
EUT AND CABLE PLACEMENT	13
CONDUCTED EMISSIONS.....	13
RADIATED EMISSIONS.....	13
RADIATED EMISSIONS.....	14
BANDWIDTH MEASUREMENTS	17
SPECIFICATION LIMITS AND SAMPLE CALCULATIONS	17
CONDUCTED EMISSIONS SPECIFICATION LIMITS: FCC 15.207; FCC 15.107(A), RSS GEN	17
GENERAL TRANSMITTER RADIATED EMISSIONS SPECIFICATION LIMITS	18
RECEIVER RADIATED SPURIOUS EMISSIONS SPECIFICATION LIMITS	18
OUTPUT POWER LIMITS – FHSS SYSTEMS	19
TRANSMIT MODE SPURIOUS RADIATED EMISSIONS LIMITS – FHSS AND DTS SYSTEMS.....	19
SAMPLE CALCULATIONS - CONDUCTED EMISSIONS	19
SAMPLE CALCULATIONS - RADIATED EMISSIONS.....	20
APPENDIX A TEST EQUIPMENT CALIBRATION DATA	1
APPENDIX B TEST DATA	3

SCOPE

An electromagnetic emissions test has been performed on the Intel Corporation model Intel® Centrino® Wireless-N 130 (models 130BNHMW and 130BNHU), pursuant to the following rules:

Industry Canada RSS-Gen Issue 2

RSS 210 Issue 7 “Low-power Licence-exempt Radiocommunication Devices (All Frequency Bands): Category I Equipment”

FCC Part 15 Subpart C

Conducted and radiated emissions data has been collected, reduced, and analyzed within this report in accordance with measurement guidelines set forth in the following reference standards and as outlined in Elliott Laboratories test procedures:

ANSI C63.4:2003

FHSS test procedure DA 00-0705A1, March 2000

The intentional radiator above has been tested in a simulated typical installation to demonstrate compliance with the relevant Industry Canada performance and procedural standards.

Final system data was gathered in a mode that tended to maximize emissions by varying orientation of EUT, orientation of power and I/O cabling, antenna search height, and antenna polarization.

Every practical effort was made to perform an impartial test using appropriate test equipment of known calibration. All pertinent factors have been applied to reach the determination of compliance.

OBJECTIVE

The primary objective of the manufacturer is compliance with the regulations outlined in the previous section.

Prior to marketing in the USA, all unlicensed transmitters and transceivers require certification. Receive-only devices operating between 30 MHz and 960 MHz are subject to either certification or a manufacturer’s declaration of conformity, with all other receive-only devices exempt from the technical requirements.

Prior to marketing in Canada, Class I transmitters, receivers and transceivers require certification. Class II devices are required to meet the appropriate technical requirements but are exempt from certification requirements.

Certification is a procedure where the manufacturer submits test data and technical information to a certification body and receives a certificate or grant of equipment authorization upon successful completion of the certification body’s review of the submitted documents. Once the equipment authorization has been obtained, the label indicating compliance must be attached to all identical units, which are subsequently manufactured.

Maintenance of compliance is the responsibility of the manufacturer. Any modification of the product which may result in increased emissions should be checked to ensure compliance has been maintained (i.e., printed circuit board layout changes, different line filter, different power supply, harnessing or I/O cable changes, etc.).

STATEMENT OF COMPLIANCE

The tested sample of Intel Corporation model Intel® Centrino® Wireless-N 130 (models 130BNHMW and 130BNHU) complied with the requirements of the following regulations:

- Industry Canada RSS-Gen Issue 2
- RSS 210 Issue 7 “Low-power Licence-exempt Radiocommunication Devices (All Frequency Bands): Category I Equipment”
- FCC Part 15 Subpart C

Maintenance of compliance is the responsibility of the manufacturer. Any modifications to the product should be assessed to determine their potential impact on the compliance status of the device with respect to the standards detailed in this test report.

The test results recorded herein are based on a single type test of Intel Corporation model Intel® Centrino® Wireless-N 130 (models 130BNHMW and 130BNHU) and therefore apply only to the tested sample. The sample was selected and prepared by Steve Hackett of Intel Corporation.

DEVIATIONS FROM THE STANDARDS

No deviations were made from the published requirements listed in the scope of this report.

TEST RESULTS SUMMARY**FREQUENCY HOPPING SPREAD SPECTRUM (2400 – 2483.5 MHz, less than 75 channels)**

FCC Rule Part	RSS Rule Part	Description	Measured Value / Comments	Limit / Requirement	Result
15.247 (a) (1)	RSS 210 A8.1 (1)	20dB Bandwidth	Basic rate 1108 kHz EDR: 1367 kHz	Channel spacing > 2/3rds 20dB BW	Complies
		Channel Separation	1000 kHz		Complies
15.247 (a) (1) (ii)	RSS 210 A8.1 (4)	Number of Channels	20 - 79	15 or more	Complies
15.247 (a) (1) (ii)	RSS 210 A8.1 (4)	Channel Dwell Time (average time of occupancy)	0.4 seconds per 0.4x number of channels seconds	<0.4 second within a period of 0.4 x number of channels	Complies
15.247 (a) (1)	RSS 210 A8.1 (1)	Channel Utilization	The system uses the Bluetooth algorithm and, therefore, meets all requirements for channel utilization.	All channels shall, on average, be used equally	Complies
15.247 (b) (3)	RSS 210 A8.4 (2)	Output Power	Basic rate: 0.0055W EDR: 0.003W EIRP = 0.011 W ^{Note 1}	0.125 Watts	Complies
15.247(c)	RSS 210 A8.5	Spurious Emissions – 30MHz – 25GHz	All spurious emissions < -20dBc	< -20dBc	Complies
15.247(c) / 15.209	RSS 210 A8.5 Table 2, 3	Radiated Spurious Emissions 30MHz – 25GHz	52.0dB μ V/m @ 2483.5MHz	15.209 in restricted bands, all others < -20dBc	Complies (-2.0dB)
15.247 (a) (1)	RSS 210 A8.1(2)	Receiver bandwidth	Refer to operational description, page 34	Shall match the channel bandwidth	Complies

Note 1: EIRP calculated using antenna gain of 3.2 dBi

GENERAL REQUIREMENTS APPLICABLE TO ALL BANDS

FCC Rule Part	RSS Rule part	Description	Measured Value / Comments	Limit / Requirement	Result (margin)
15.203	-	RF Connector	Unique	Integral or unique connector required	Complies
15.109	RSS GEN 7.2.3 Table 1	Receiver spurious emissions	41.7dB μ V/m @ 1331.2MHz	Refer to page 18	Complies (-12.3dB)
15.207	RSS GEN Table 2	AC Conducted Emissions	41.7dB μ V @ 15.505MHz	Refer to page 17	Complies (-8.3dB)
15.247 (b) (5) / 15.407 (f)	RSS 102	RF Exposure Requirements	Refer to MPE calculations, RSS 102 declaration and User Manual page 8	Refer to OET 65, FCC Part 1 and RSS 102	Complies
-	RSP 100 RSS GEN 7.1.5	User Manual	Refer to pages 11 and 12 of the user's manual	Statement required regarding non-interference	Complies
-	RSP 100 RSS GEN 7.1.5	User Manual	Not applicable, antenna is integral to host systems.	Statement for products with detachable antenna	Complies
-	RSP 100 RSS GEN 4.4.1	99% Bandwidth	Basic Rate: 973 kHz EDR: 1240 kHz	Information only	N/A

ADDITIONAL MEASUREMENTS

As both Bluetooth and 802.11 transmissions can occur simultaneously, radiated spurious measurements were made with both Bluetooth and 802.11 devices transmitting simultaneously.

FCC Rule Part	RSS Rule part	Description	Measured Value / Comments	Limit / Requirement	Result (margin)
15.2109	RSS 210	Receiver spurious emissions	51.0dB μ V/m @ 2496.2MHz	15.209 in restricted bands, all others < -20dBc	Complies (-3.0dB)

MEASUREMENT UNCERTAINTIES

ISO/IEC 17025 requires that an estimate of the measurement uncertainties associated with the emissions test results be included in the report. The measurement uncertainties given below are based on a 95% confidence level and were calculated in accordance with UKAS document LAB 34.

Measurement Type	Measurement Unit	Frequency Range	Expanded Uncertainty
RF power, conducted (power meter)	dBm	25 to 7000 MHz	± 0.52 dB
RF power, conducted (Spectrum analyzer)	dBm	25 to 7000 MHz	± 0.7 dB
Conducted emission of transmitter	dBm	25 to 26500 MHz	± 0.7 dB
Conducted emission of receiver	dBm	25 to 26500 MHz	± 0.7 dB
Radiated emission (substitution method)	dBm	25 to 26500 MHz	± 2.5 dB
Radiated emission (field strength)	dB μ V/m	25 to 1000 MHz	± 3.6 dB
		1000 to 40000 MHz	± 6.0 dB
Conducted Emissions (AC Power)	dB μ V	0.15 to 30 MHz	± 2.4 dB

EQUIPMENT UNDER TEST (EUT) DETAILS**GENERAL**

The Intel Corporation model Intel® Centrino® Wireless-N 130 is a PCIe Half Mini Card form factor Bluetooth / IEEE 802.11b/g/n wireless network adapter that supports 1x1 (SISO) for 802.11bgn modes. Bluetooth operation supports a 1x1 mode.

The card is sold under two different model numbers:

The Intel® Centrino® Wireless-N 130 is sold under model numbers 130BNHMW and 130BNHU

Model numbers with FCC ID: PD9130BNHU and IC: 1000M-130BNHU are intended for end user installation and operate with a BIOS lock feature to ensure they can only be used in the appropriate host systems to prevent unauthorized operation. Other models are only intended for OEM factory installation.

For radio testing purposes the card was installed in a test fixture that exposed all sides of the card. For digital device testing for certification under equipment code JBP the card was installed inside a laptop PC.

The sample was received on September 2, 2010 and tested on September 8, 13, 14, and 15, 2010. The EUT consisted of the following component(s):

Company	Model	Description	Mac Address	FCC ID
Intel Corporation	130BNHMW	PCIe Half Mini Card form factor Bluetooth / IEEE 802.11b/g/n wireless network adapter	00150079C6BF	PD9130BNH
	130BNHU			PD9130BNHU 1000M-130BNH
				1000M-130BNHU

ANTENNA SYSTEM

The EUT antenna is a a two-antenna PIFA antenna system – Shanghai Universe Communication Electron Co., Ltd. The antenna connects to the EUT via a non-standard antenna connector, thereby meeting the requirements of FCC 15.203.

ENCLOSURE

The EUT does not have an enclosure as it is designed to be installed within the enclosure of a host computer or system.

MODIFICATIONS

No modifications were made to the EUT during the time the product was at Elliott.

SUPPORT EQUIPMENT

The following equipment was used as support equipment for testing:

Company	Model	Description	Serial Number	FCC ID
Intel Corporation	Shiloh Motherboard	Test Fixture	-	N/A
Dell	-	Laptop PC	Prototype	N/A
Agilent	E3610A	DC Supply	-	N/A

EUT INTERFACE PORTS

The I/O cabling configuration during testing was as follows:

Port	Connected To	Description	Cable(s)	
			Shielded or Unshielded	Length(m)
Laptop USB	Fixture USB	USB cable	Shielded	1
Laptop Mini PCI	Fixture PCIe	Ribbon	unshielded	0.5
DC Power	Fixture DC power	2-wire	unshielded	0.5

EUT OPERATION

The EUT was installed into a test fixture that exposed all sides of the card. The test fixture interfaced to a laptop computer and dc power supply. The laptop computer was used to configure the EUT to continuously transmit at a specified output power or continuously receive on the channel specified in the test data. For transmit mode measurements the system was configured to operate in each of the available operating modes – 802.11b, 802.11g, 802.11n (20 MHz channel bandwidth) and 802.11n (40MHz channel bandwidth), Bluetooth 1Mb/s and Bluetooth 3Mb/s. In addition radiated spurious tests were repeated with the device operating in both Bluetooth and 802.11 modes to determine if any spurious emissions due to inter-modulation products were created.

The data rates used for all tests were the lowest data rates for each 802.11 mode – 1Mb/s for 802.11b, 6Mb/s for 802.11a and 802.11g, 6.5MB/s for 802.11n (20MHz), and 13 Mb/s for 802.11n (40MHz). The device operates at its maximum output power at the lowest data rate (this was confirmed through separate measurements). Bluetooth operation was evaluated at both 1Mb/s and 3Mb/s data rates. 2Mb/s data rate was found, through preliminary testing, to produce emissions similar to those for 3Mb/s and had a slightly lower output power than the 3Mb/s data rate.

The PC was using the Intel test utility DRTU Version 1.2.2-0177 and the driver version 14.0.0.39.

TEST SITE**GENERAL INFORMATION**

Final test measurements were taken at the test sites listed below. Pursuant to section 2.948 of the FCC's Rules and section 3.3 of RSP-100, construction, calibration, and equipment data has been filed with the Commission and with industry Canada.

Site	Registration Numbers		Location
	FCC	Canada	
Chamber 4	211948	2845B-4	41039 Boyce Road Fremont, CA 94538-2435
Chamber 5	211948	2845B-5	
Chamber 7	A2LA accreditation	2845B-7	

ANSI C63.4:2003 recommends that ambient noise at the test site be at least 6 dB below the allowable limits. Ambient levels are below this requirement. The test site(s) contain separate areas for radiated and conducted emissions testing. Considerable engineering effort has been expended to ensure that the facilities conform to all pertinent requirements of ANSI C63.4:2003.

CONDUCTED EMISSIONS CONSIDERATIONS

Conducted emissions testing is performed in conformance with ANSI C63.4:2003. Measurements are made with the EUT connected to the public power network through a nominal, standardized RF impedance, which is provided by a line impedance stabilization network, known as a LISN. A LISN is inserted in series with each current-carrying conductor in the EUT power cord.

RADIATED EMISSIONS CONSIDERATIONS

The FCC has determined that radiation measurements made in a shielded enclosure are not suitable for determining levels of radiated emissions. Radiated measurements are performed in an open field environment or in a semi-anechoic chamber. The test sites are maintained free of conductive objects within the CISPR defined elliptical area incorporated in ANSI C63.4:2003 guidelines and meet the Normalized Site Attenuation (NSA) requirements of ANSI C63.4:2003.

MEASUREMENT INSTRUMENTATION

RECEIVER SYSTEM

An EMI receiver as specified in CISPR 16-1-1 is used for emissions measurements. The receivers used can measure over the frequency range of 9 kHz up to 2000 MHz. These receivers allow both ease of measurement and high accuracy to be achieved. The receivers have Peak, Average, and CISPR (Quasi-peak) detectors built into their design so no external adapters are necessary. The receiver automatically sets the required bandwidth for the CISPR detector used during measurements. If the repetition frequency of the signal being measured is below 20Hz, peak measurements are made in lieu of Quasi-Peak measurements.

For measurements above the frequency range of the receivers, a spectrum analyzer is utilized because it provides visibility of the entire spectrum along with the precision and versatility required to support engineering analysis. Average measurements above 1000MHz are performed on the spectrum analyzer using the linear-average method with a resolution bandwidth of 1 MHz and a video bandwidth of 10 Hz, unless the signal is pulsed in which case the average (or video) bandwidth of the measuring instrument is reduced to onset of pulse desensitization and then increased.

INSTRUMENT CONTROL COMPUTER

The receivers utilize either a Rohde & Schwarz EZM Spectrum Monitor/Controller or contain an internal Spectrum Monitor/Controller to view and convert the receiver measurements to the field strength at an antenna or voltage developed at the LISN measurement port, which is then compared directly with the appropriate specification limit. This provides faster, more accurate readings by performing the conversions described under Sample Calculations within the Test Procedures section of this report. Results are printed in a graphic and/or tabular format, as appropriate. A personal computer is used to record all measurements made with the receivers.

The Spectrum Monitor provides a visual display of the signal being measured. In addition, the controller or a personal computer run automated data collection programs which control the receivers. This provides added accuracy since all site correction factors, such as cable loss and antenna factors are added automatically.

LINE IMPEDANCE STABILIZATION NETWORK (LISN)

Line conducted measurements utilize a fifty microhenry Line Impedance Stabilization Network as the monitoring point. The LISN used also contains a 250 uH CISPR adapter. This network provides for calibrated radio frequency noise measurements by the design of the internal low pass and high pass filters on the EUT and measurement ports, respectively.

FILTERS/ATTENUATORS

External filters and precision attenuators are often connected between the receiving antenna or LISN and the receiver. This eliminates saturation effects and non-linear operation due to high amplitude transient events.

ANTENNAS

A loop antenna is used below 30 MHz. For the measurement range 30 MHz to 1000 MHz either a combination of a biconical antenna and a log periodic or a bi-log antenna is used. Above 1000 MHz, horn antennas are used. The antenna calibration factors to convert the received voltage to an electric field strength are included with appropriate cable loss and amplifier gain factors to determine an overall site factor, which is then programmed into the test receivers or incorporated into the test software.

ANTENNA MAST AND EQUIPMENT TURNTABLE

The antennas used to measure the radiated electric field strength are mounted on a non-conductive antenna mast equipped with a motor-drive to vary the antenna height. Measurements below 30 MHz are made with the loop antenna at a fixed height of 1m above the ground plane.

ANSI C63.4:2003 specifies that the test height above ground for table mounted devices shall be 80 centimeters. Floor mounted equipment shall be placed on the ground plane if the device is normally used on a conductive floor or separated from the ground plane by insulating material from 3 to 12 mm if the device is normally used on a non-conductive floor. During radiated measurements, the EUT is positioned on a motorized turntable in conformance with this requirement.

INSTRUMENT CALIBRATION

All test equipment is regularly checked to ensure that performance is maintained in accordance with the manufacturer's specifications. All antennas are calibrated at regular intervals with respect to tuned half-wave dipoles. An exhibit of this report contains the list of test equipment used and calibration information.

TEST PROCEDURES

EUT AND CABLE PLACEMENT

The regulations require that interconnecting cables be connected to the available ports of the unit and that the placement of the unit and the attached cables simulate the worst case orientation that can be expected from a typical installation, so far as practicable. To this end, the position of the unit and associated cabling is varied within the guidelines of ANSI C63.4:2003, and the worst-case orientation is used for final measurements.

CONDUCTED EMISSIONS

Conducted emissions are measured at the plug end of the power cord supplied with the EUT. Excess power cord length is wrapped in a bundle between 30 and 40 centimeters in length near the center of the cord. Preliminary measurements are made to determine the highest amplitude emission relative to the specification limit for all the modes of operation. Placement of system components and varying of cable positions are performed in each mode. A final peak mode scan is then performed in the position and mode for which the highest emission was noted on all current carrying conductors of the power cord.

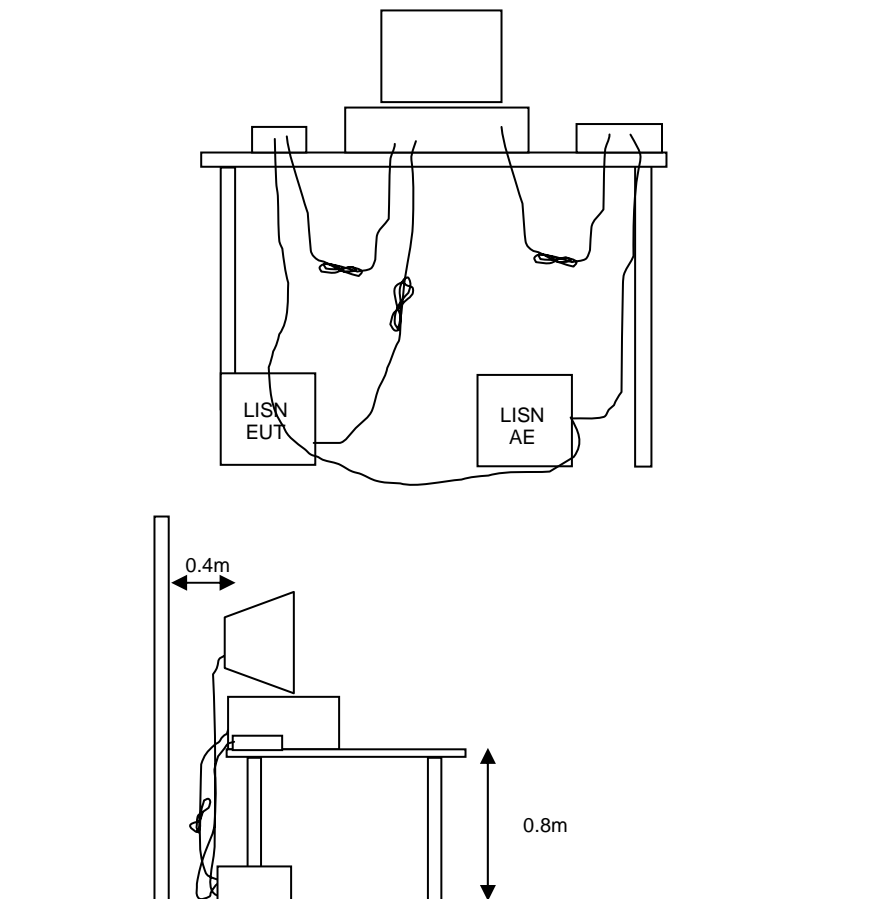

RADIATED EMISSIONS

A preliminary scan of the radiated emissions is performed in which all significant EUT frequencies are identified with the system in a nominal configuration. At least two scans are performed, one scan for each antenna polarization (horizontal and vertical; loop parallel and perpendicular to the EUT). During the preliminary scans, the EUT is rotated through 360°, the antenna height is varied (for measurements above 30 MHz) and cable positions are varied to determine the highest emission relative to the limit. Preliminary scans may be performed in a fully anechoic chamber for the purposes of identifying the frequencies of the highest emissions from the EUT.

A speaker is provided in the receiver to aid in discriminating between EUT and ambient emissions. Other methods used during the preliminary scan for EUT emissions involve scanning with near field magnetic loops, monitoring I/O cables with RF current clamps, and cycling power to the EUT.

Final maximization is a phase in which the highest amplitude emissions identified in the spectral search are viewed while the EUT azimuth angle is varied from 0 to 360 degrees relative to the receiving antenna. The azimuth, which results in the highest emission is then maintained while varying the antenna height from one to four meters (for measurements above 30 MHz, measurements below 30 MHz are made with the loop antenna at a fixed height of 1m). The result is the identification of the highest amplitude for each of the highest peaks. Each recorded level is corrected in the receiver using appropriate factors for cables, connectors, antennas, and preamplifier gain.

When testing above 18 GHz, the receive antenna is located at 1 meter from the EUT and the antenna height is restricted to a maximum of 2.5 meters.

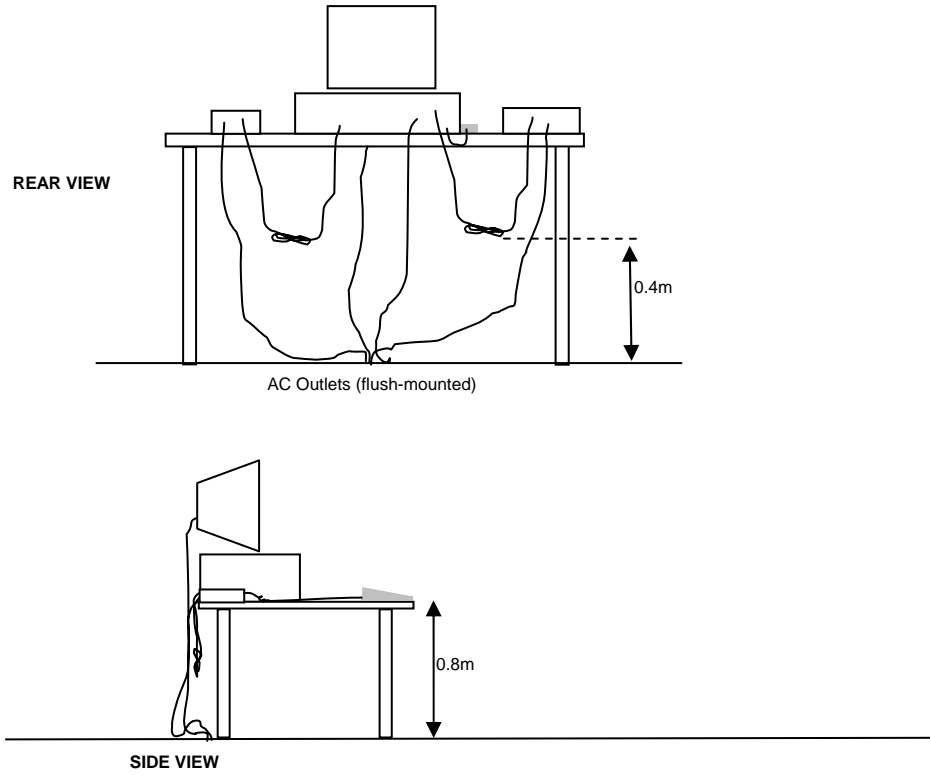

Typical Test Configuration for Radiated Field Strength Measurements

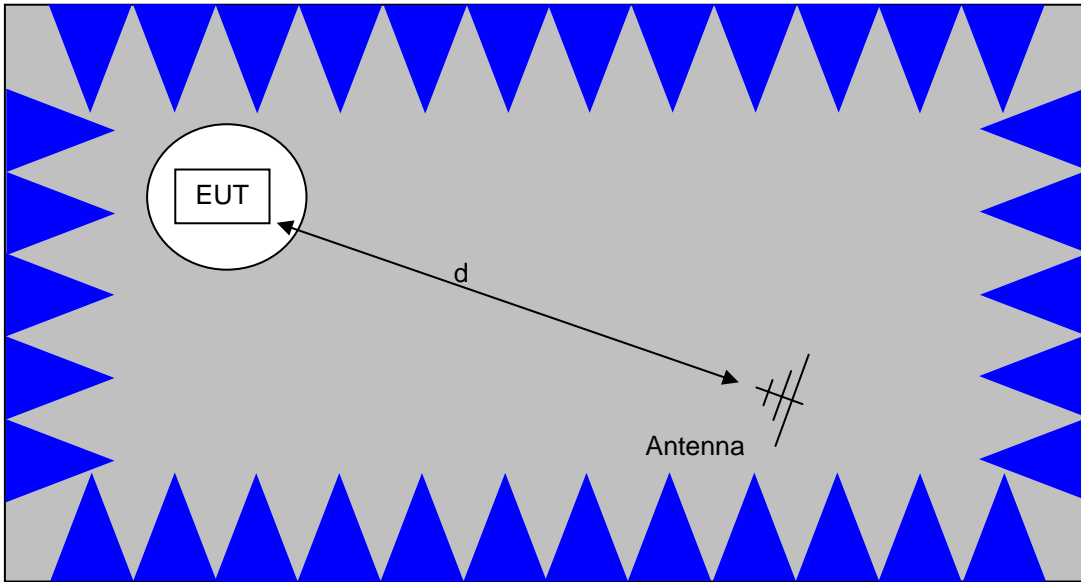

The anechoic materials on the walls and ceiling ensure compliance with the normalized site attenuation requirements of CISPR 16 / CISPR 22 / ANSI C63.4 for an alternate test site at the measurement distances used.

Floor-standing equipment is placed on the floor with insulating supports between the unit and the ground plane.

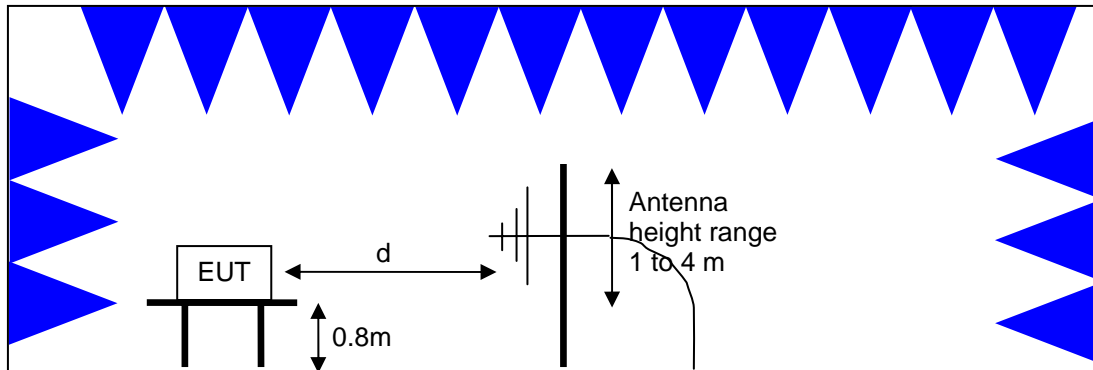

Test Configuration for Radiated Field Strength Measurements
Semi-Anechoic Chamber, Plan and Side Views

BANDWIDTH MEASUREMENTS

The 6dB, 20dB and/or 26dB signal bandwidth is measured in using the bandwidths recommended by ANSI C63.4. When required, the 99% bandwidth is measured using the methods detailed in RSS GEN.

SPECIFICATION LIMITS AND SAMPLE CALCULATIONS

The limits for conducted emissions are given in units of microvolts, and the limits for radiated emissions are given in units of microvolts per meter at a specified test distance. Data is measured in the logarithmic form of decibels relative to one microvolt, or dB microvolts (dBuV). For radiated emissions, the measured data is converted to the field strength at the antenna in dB microvolts per meter (dBuV/m). The results are then converted to the linear forms of uV and uV/m for comparison to published specifications.

For reference, converting the specification limits from linear to decibel form is accomplished by taking the base ten logarithm, then multiplying by 20. These limits in both linear and logarithmic form are as follows:

CONDUCTED EMISSIONS SPECIFICATION LIMITS: FCC 15.207; FCC 15.107(a), RSS GEN

The table below shows the limits for the emissions on the AC power line from an intentional radiator and a receiver.

Frequency (MHz)	Average Limit (dBuV)	Quasi Peak Limit (dBuV)
0.150 to 0.500	Linear decrease on logarithmic frequency axis between 56.0 and 46.0	Linear decrease on logarithmic frequency axis between 66.0 and 56.0
0.500 to 5.000	46.0	56.0
5.000 to 30.000	50.0	60.0

GENERAL TRANSMITTER RADIATED EMISSIONS SPECIFICATION LIMITS

The table below shows the limits for the spurious emissions from transmitters that fall in restricted bands¹ (with the exception of transmitters operating under FCC Part 15 Subpart D and RSS 210 Annex 9), the limits for all emissions from a low power device operating under the general rules of RSS 310 (tables 3 and 4), RSS 210 (table 2) and FCC Part 15 Subpart C section 15.209.

Frequency Range (MHz)	Limit (uV/m)	Limit (dBuV/m @ 3m)
0.009-0.490	2400/F _{KHz} @ 300m	67.6-20*log ₁₀ (F _{KHz}) @ 300m
0.490-1.705	24000/F _{KHz} @ 30m	87.6-20*log ₁₀ (F _{KHz}) @ 30m
1.705 to 30	30 @ 30m	29.5 @ 30m
30 to 88	100 @ 3m	40 @ 3m
88 to 216	150 @ 3m	43.5 @ 3m
216 to 960	200 @ 3m	46.0 @ 3m
Above 960	500 @ 3m	54.0 @ 3m

RECEIVER RADIATED SPURIOUS EMISSIONS SPECIFICATION LIMITS

The table below shows the limits for the spurious emissions from receivers as detailed in FCC Part 15.109, RSS 210 Table 2, RSS GEN Table 1 and RSS 310 Table 3. Note that receivers operating outside of the frequency range 30 MHz – 960 MHz are exempt from the requirements of 15.109.

Frequency Range (MHz)	Limit (uV/m @ 3m)	Limit (dBuV/m @ 3m)
30 to 88	100	40
88 to 216	150	43.5
216 to 960	200	46.0
Above 960	500	54.0

¹ The restricted bands are detailed in FCC 15.203, RSS 210 Table 1 and RSS 310 Table 2

OUTPUT POWER LIMITS – FHSS SYSTEMS

The table below shows the limits for output power based on the number of channels available for the hopping system.

Operating Frequency (MHz)	Number of Channels	Output Power
902 – 928	≥ 50	1 Watt (30 dBm)
902 – 928	25 to 49	0.25 Watts (24 dBm)
2400 – 2483.5	≥ 75	1 Watt (30 dBm)
2400 – 2483.5	< 75	0.125 Watts (21 dBm)
5725 – 5850	75	1 Watt (30 dBm)

The maximum permitted output power is reduced by 1dB for every dB the antenna gain exceeds 6dBi. Fixed point-to-point applications using the 5725 – 5850 MHz band are not subject to this restriction.

TRANSMIT MODE SPURIOUS RADIATED EMISSIONS LIMITS – FHSS and DTS SYSTEMS

The limits for unwanted (spurious) emissions from the transmitter falling in the restricted bands are those specified in the general limits sections of FCC Part 15 and RSS 210. All other unwanted (spurious) emissions shall be at least 20dB below the level of the highest in-band signal level (30dB if the power is measured using the sample detector/power averaging method).

SAMPLE CALCULATIONS - CONDUCTED EMISSIONS

Receiver readings are compared directly to the conducted emissions specification limit (decibel form) as follows:

$$R_T - S = M$$

where:

R_T = Receiver Reading in dBuV

S = Specification Limit in dBuV

M = Margin to Specification in +/- dB

SAMPLE CALCULATIONS - RADIATED EMISSIONS

Receiver readings are compared directly to the specification limit (decibel form). The receiver internally corrects for cable loss, preamplifier gain, and antenna factor. The calculations are in the reverse direction of the actual signal flow, thus cable loss is added and the amplifier gain is subtracted. The Antenna Factor converts the voltage at the antenna coaxial connector to the field strength at the antenna elements.

A distance factor, when used for electric field measurements above 30MHz, is calculated by using the following formula:

$$F_d = 20 * \text{LOG}_{10} (D_m/D_s)$$

where:

$$F_d = \text{Distance Factor in dB}$$

$$D_m = \text{Measurement Distance in meters}$$

$$D_s = \text{Specification Distance in meters}$$

For electric field measurements below 30MHz the extrapolation factor is either determined by making measurements at multiple distances or a theoretical value is calculated using the formula:

$$F_d = 40 * \text{LOG}_{10} (D_m/D_s)$$

Measurement Distance is the distance at which the measurements were taken and Specification Distance is the distance at which the specification limits are based. The antenna factor converts the voltage at the antenna coaxial connector to the field strength at the antenna elements.

The margin of a given emission peak relative to the limit is calculated as follows:

$$R_c = R_r + F_d$$

and

$$M = R_c - L_s$$

where:

$$R_r = \text{Receiver Reading in dBuV/m}$$

$$F_d = \text{Distance Factor in dB}$$

$$R_c = \text{Corrected Reading in dBuV/m}$$

$$L_s = \text{Specification Limit in dBuV/m}$$

$$M = \text{Margin in dB Relative to Spec}$$

Appendix A Test Equipment Calibration Data**Radio Bandedge (Power and Spurious Emissions), 08-Sep-10**

<u>Manufacturer</u>	<u>Description</u>	<u>Model</u>	<u>Asset #</u>	<u>Cal Due</u>
EMCO	Antenna, Horn, 1-18 GHz	3115	487	7/6/2012
Hewlett Packard	SpecAn 9 kHz - 40 GHz, FT (SA40) Blue	8564E (84125C)	1393	4/14/2011
Hewlett Packard	Microwave Preamplifier, 1-26.5GHz	8449B	785	5/26/2011
EMCO	Antenna, Horn, 1-18GHz	3115	868	6/8/2012
Hewlett Packard	SpecAn 30 Hz -40 GHz, SV (SA40) Red	8564E (84125C)	1148	7/12/2011
Rohde & Schwarz	Power Meter, Single Channel	NRVS	1290	10/22/2010
Rohde & Schwarz	Power Sensor 100 uW - 10 Watts	NRV-Z53	1555	2/5/2011
Rohde & Schwarz	Attenuator, 20 dB , 50 ohm, 10W, DC-18 GHz	20dB, 10W, Type N	1556	2/5/2011
Micro-Tronics	Band Reject Filter, 2400-2500 MHz	BRM50702-02	1731	11/4/2010

Radiated Emissions, 1000 - 26,500 MHz, 11-Sep-10

<u>Manufacturer</u>	<u>Description</u>	<u>Model</u>	<u>Asset #</u>	<u>Cal Due</u>
Hewlett Packard	Microwave Preamplifier, 1-26.5GHz	8449B	263	12/15/2010
EMCO	Antenna, Horn, 1-18 GHz	3115	487	7/6/2012
Rohde & Schwarz	Power Meter, Single Channel	NRVS	1290	10/22/2010
Hewlett Packard	SpecAn 9 kHz - 40 GHz, FT (SA40) Blue	8564E (84125C)	1393	4/14/2011
Rohde & Schwarz	Power Sensor 100 uW - 10 Watts	NRV-Z53	1555	2/5/2011
Rohde & Schwarz	Attenuator, 20 dB , 50 ohm, 10W, DC-18 GHz	20dB, 10W, Type N	1556	2/5/2011
EMCO	Antenna, Horn, 1-18 GHz	3115	1561	6/22/2012
Hewlett Packard	Head (Inc W1-W4, 1742 , 1743) Blue	84125C	1620	5/4/2011
Micro-Tronics	Band Reject Filter, 2400-2500 MHz	BRM50702-02	1731	11/4/2010
A.H. Systems	Red System Horn, 18-40GHz	SAS-574, p/n: 2581	2161	3/5/2011

Radio Antenna Port, 14/15-Sep-10

<u>Manufacturer</u>	<u>Description</u>	<u>Model</u>	<u>Asset #</u>	<u>Cal Due</u>
Rohde & Schwarz	Power Meter, Single Channel	NRVS	1290	10/22/2010
Rohde & Schwarz	Power Sensor 100 uW - 2 Watts (w/ 20 dB pad, SN BJ5155)	NRV-Z32	1536	9/13/2011
Rohde & Schwarz	Power Sensor 100 uW - 10 Watts	NRV-Z53	1555	2/5/2011
Rohde & Schwarz	Attenuator, 20 dB , 50 ohm, 10W, DC-18 GHz	20dB, 10W, Type N	1556	2/5/2011
Hewlett Packard	SpecAn 9 kHz - 40 GHz, (SA40) Purple	8564E (84125C)	1771	8/26/2011

Radiated Emissions, 30 - 1,000 MHz, 15-Sep-10

<u>Manufacturer</u>	<u>Description</u>	<u>Model</u>	<u>Asset #</u>	<u>Cal Due</u>
Rohde & Schwarz	EMI Test Receiver, 20 Hz-7 GHz	ESIB7	1538	10/15/2010
Hewlett Packard	Preamplifier, 100 kHz - 1.3 GHz	8447D OPT 010	1826	5/27/2011
Sunol Sciences	Biconilog, 30-3000 MHz	JB3	2197	12/29/2011

Conducted Emissions - AC Power Ports, 15-Sep-10

<u>Manufacturer</u>	<u>Description</u>	<u>Model</u>	<u>Asset #</u>	<u>Cal Due</u>
EMCO	LISN, 10 kHz-100 MHz	3825/2	1292	3/12/2011
Rohde & Schwarz	EMI Test Receiver, 20 Hz-7 GHz	ESIB7	1538	10/15/2010
Fischer Custom Comm.	LISN, 50uH, 25 Amps, Dual Line	FCC-LISN-50/250- 25-2-01	1575	4/19/2011
Rohde & Schwarz	Pulse Limiter	ESH3 Z2	1593	5/27/2011

Appendix B Test Data

T80458 50 Pages



EMC Test Data

Client:	Intel Corporation	Job Number:	J80397
Model:	Intel® Centrino® Wireless-N 1030 and Intel® Centrino® Wireless-N 130	T-Log Number:	T80458
Contact:	Steve Hackett	Account Manager:	Christine Krebill
Emissions Standard(s):	FCC.247, RSS-210 Issue 7	Class:	B
Immunity Standard(s):	-	Environment:	-

EMC Test Data

For The

Intel Corporation

Model

Intel® Centrino® Wireless-N 1030 and Intel® Centrino® Wireless-N 130

Date of Last Test: 9/15/2010

Client:	Intel Corporation	Job Number:	J80397
Model:	Intel® Centrino® Wireless-N 1030 and Intel® Centrino® Wireless-N 130	T-Log Number:	T80458
		Account Manager:	Christine Krebill
Contact:	Steve Hackett		
Standard:	FCC.247, RSS-210 Issue 7	Class:	B

Conducted Emissions

(Elliott Laboratories Fremont Facility, Semi-Anechoic Chamber)

Test Specific Details

Objective: The objective of this test session is to perform final qualification testing of the EUT with respect to the specification listed above.

Date of Test: 9/15/2010
 Test Engineer: Rafael Varelas
 Test Location: FT Chamber #4

Config. Used: Modular Test
 Config Change: None
 Host Unit Voltage 120V/60Hz

General Test Configuration

The test fixture was located on a wooden table inside the semi-anechoic chamber, 40 cm from a vertical coupling plane and 80cm from the LISN. A second LISN was used for all local support equipment.

Ambient Conditions:

Temperature: 21.6 °C
 Rel. Humidity: 37 %

Summary of Results

MAC Address: 00150079C6BF DRTU Tool Version 1.2.2-0177 Driver version 14.0.0.39

Run #	Test Performed	Limit	Result	Margin
1	CE, AC Power, 120V/60Hz	RSS 210 / 15.207	Pass	41.7dBµV @ 15.505MHz (-8.3dB)

Modifications Made During Testing

No modifications were made to the EUT during testing

Deviations From The Standard

No deviations were made from the requirements of the standard.

Client: Intel Corporation	Job Number: J80397
Model: Intel® Centrino® Wireless-N 1030 and Intel® Centrino® Wireless-N 130	T-Log Number: T80458
	Account Manager: Christine Krebill
Contact: Steve Hackett	
Standard: FCC.247, RSS-210 Issue 7	Class: B

Run #1: AC Power Port Conducted Emissions, 0.15 - 30MHz, 120V/50Hz
Preliminary peak readings captured during pre-scan (peak readings vs. average limit)

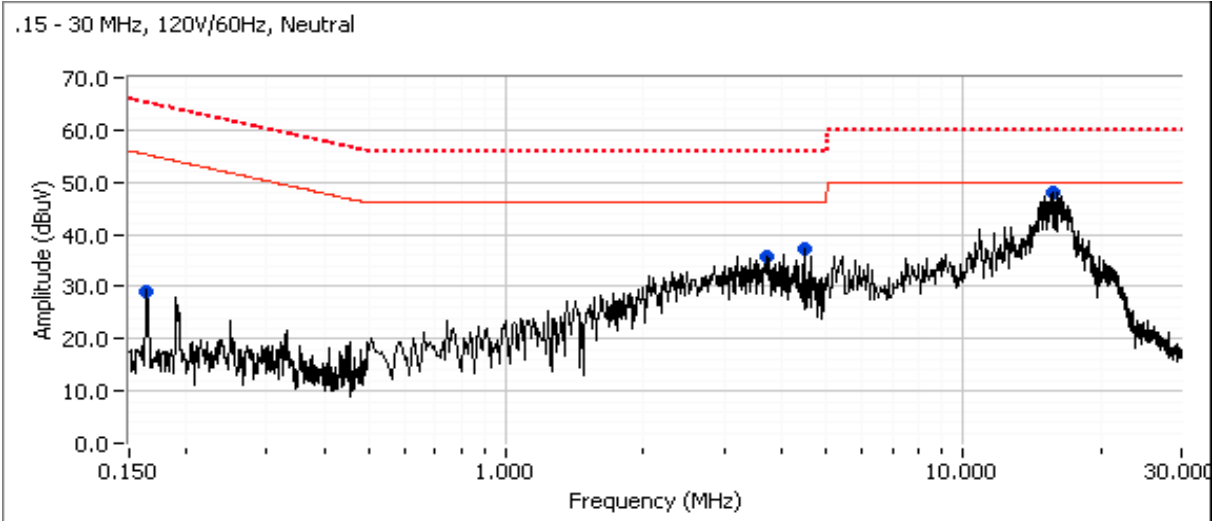
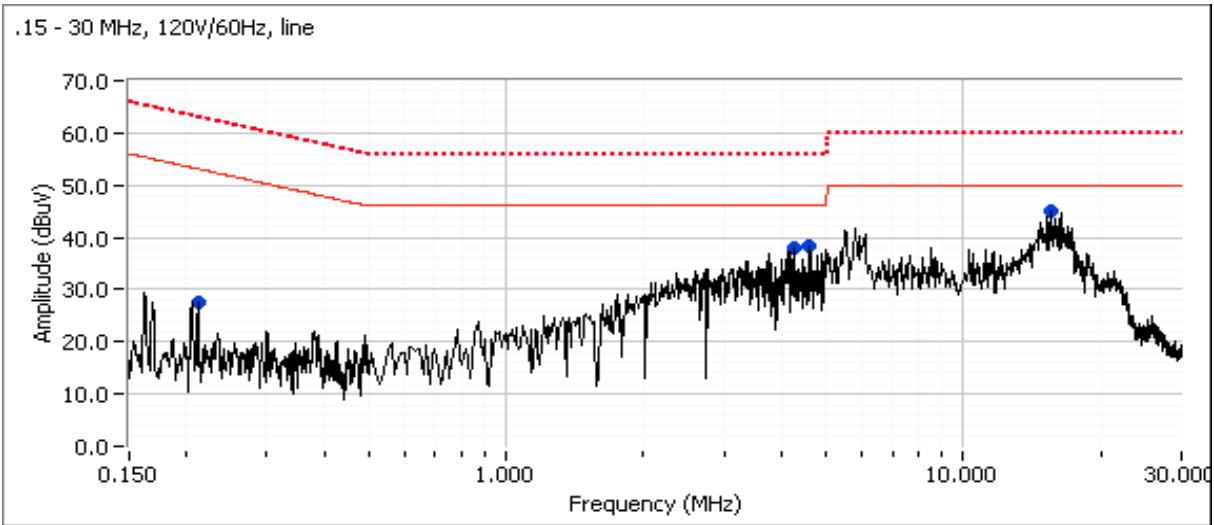

Client:	Intel Corporation	Job Number:	J80397
Model:	Intel® Centrino® Wireless-N 1030 and Intel® Centrino® Wireless-N 130	T-Log Number:	T80458
		Account Manager:	Christine Krebill
Contact:	Steve Hackett		
Standard:	FCC.247, RSS-210 Issue 7	Class:	B

Frequency MHz	Level dB μ V	AC Line	Class B		Detector QP/Ave	Comments
			Limit	Margin		
0.213	27.4	Line 1	53.1	-25.7	Peak	
4.229	38.1	Line 1	46.0	-7.9	Peak	
4.617	38.4	Line 1	46.0	-7.6	Peak	
15.408	45.1	Line 1	50.0	-4.9	Peak	
0.164	29.2	Neutral	55.3	-26.1	Peak	
4.468	37.3	Neutral	46.0	-8.7	Peak	
3.731	35.6	Neutral	46.0	-10.4	Peak	
15.505	48.1	Neutral	50.0	-1.9	Peak	

Final quasi-peak and average readings

Frequency MHz	Level dB μ V	AC Line	Class B		Detector QP/Ave	Comments
			Limit	Margin		
15.505	41.7	Neutral	50.0	-8.3	AVG	AVG (0.10s)
15.408	38.0	Line 1	50.0	-12.0	AVG	AVG (0.10s)
15.505	46.4	Neutral	60.0	-13.6	QP	QP (1.00s)
15.408	42.8	Line 1	60.0	-17.2	QP	QP (1.00s)
3.731	31.4	Neutral	56.0	-24.6	QP	QP (1.00s)
4.229	30.6	Line 1	56.0	-25.4	QP	QP (1.00s)
4.617	29.7	Line 1	56.0	-26.3	QP	QP (1.00s)
4.468	29.6	Neutral	56.0	-26.4	QP	QP (1.00s)
3.731	19.4	Neutral	46.0	-26.6	AVG	AVG (0.10s)
4.229	18.7	Line 1	46.0	-27.3	AVG	AVG (0.10s)
4.617	18.2	Line 1	46.0	-27.8	AVG	AVG (0.10s)
4.468	15.8	Neutral	46.0	-30.2	AVG	AVG (0.10s)

Client:	Intel Corporation	Job Number:	J80397
Model:	Intel® Centrino® Wireless-N 1030 and Intel® Centrino® Wireless-N 130	T-Log Number:	T80458
Contact:	Steve Hackett	Account Manager:	Christine Krebill
Standard:	FCC.247, RSS-210 Issue 7	Class:	B

Radiated Emissions 30-1000 MHz, Wireless Module (FCC 15.247/RSS 210)

(Elliott Laboratories Fremont Facility, Semi-Anechoic Chamber)

Test Specific Details

Objective: The objective of this test session is to perform final qualification testing of the EUT with respect to the specification listed above.

Date of Test: 9/15/2010	Config. Used: Modular Test
Test Engineer: Rafael Varelas	Config Change: None
Test Location: FT Chamber #4	Host Unit Voltage 120V/60Hz

General Test Configuration

The EUT and any local support equipment were located on the turntable for radiated emissions testing. Any remote support equipment was located outside the semi-anechoic chamber. Any cables running to remote support equipment were routed through metal conduit and when possible passed through a ferrite clamp upon exiting the chamber.

The test distance and extrapolation factor (if applicable) are detailed under each run description.

Note, preliminary testing indicates that the emissions were maximized by orientation of the EUT and elevation of the measurement antenna. Maximized testing indicated that the emissions were maximized by orientation of the EUT, elevation of the measurement antenna, and manipulation of the EUT's interface cables.

Ambient Conditions:

Temperature:	21.6 °C
Rel. Humidity:	37 %

Summary of Results

MAC Address: 00150079C6BF DRTU Tool Version 1.2.2-0177 Driver version 14.0.0.39

Run #	Test Performed	Limit	Result	Margin
1	Radiated Emissions 30 - 1000 MHz	FCC 15.209 / RSS 210	Pass	30.2dBµV/m @ 200.01MHz (-13.3dB)

Note - preliminary measurements indicated that the radiated emissions from the combination of test fixture and EUT were not affected by the modules operating frequency or mode (transmit versus receive mode). The system was therefore evaluated against the most stringent set of limits from FCC 15.247, FCC 15E and RSS 210 with the **device operating at max power (16.5dBm) on Chain A at 2437MHz, 802.11b mode and max power (7dBm) on the top channel in Bluetooth mode (1Mb/s data rate).**

Modifications Made During Testing

No modifications were made to the EUT during testing

Deviations From The Standard

No deviations were made from the requirements of the standard.

Client:	Intel Corporation	Job Number:	J80397
Model:	Intel® Centrino® Wireless-N 1030 and Intel® Centrino® Wireless-N 130	T-Log Number:	T80458
Contact:	Steve Hackett	Account Manager:	Christine Krebill
Standard:	FCC.247, RSS-210 Issue 7	Class:	B

Run #1: Preliminary Radiated Emissions, 30 - 1000 MHz

Configured to TX , 802.11b 16.5dBm on each chain (settings 20.0) on channel 6, Bluetooth 7dBm, 1Mb/s (settings 8.0)

Frequency Range	Test Distance	Limit Distance	Extrapolation Factor
30 - 1000 MHz	3	3	0.0

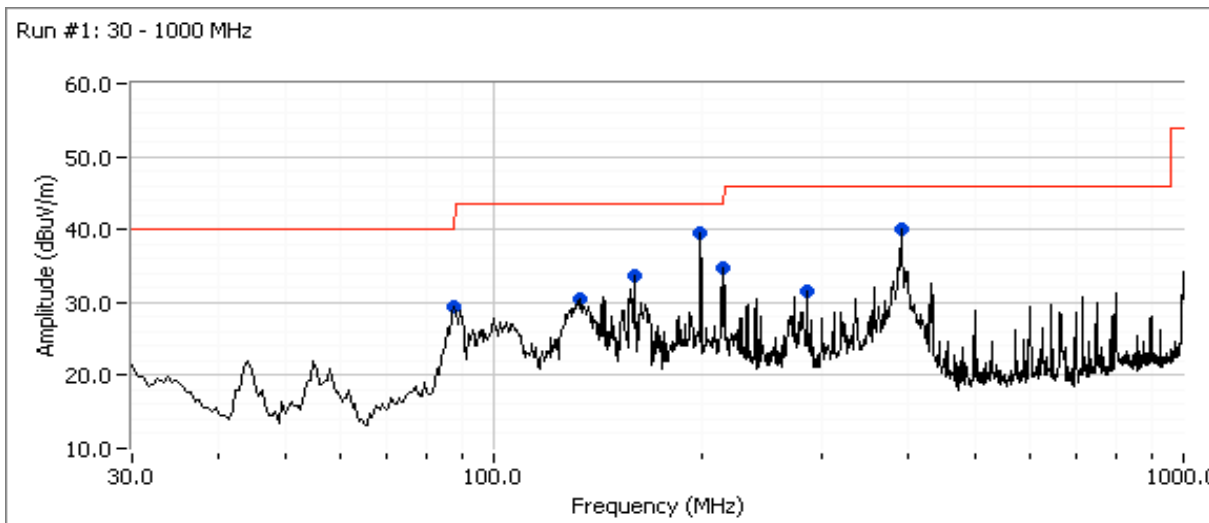

Preliminary peak readings captured during pre-scan

Frequency	Level	Pol	FCC 15.209 / RSS 210		Detector	Azimuth	Height	Comments
MHz	dBuV/m	v/h	Limit	Margin	Pk/QP/Avg	degrees	meters	
89.727	29.4	H	40.0	-10.6	Peak	52	2.0	
133.637	30.5	V	43.5	-13.0	Peak	175	2.0	
160.029	33.8	H	43.5	-9.7	Peak	217	2.0	
200.008	39.6	H	43.5	-3.9	Peak	218	1.5	
216.011	34.7	H	43.5	-8.8	Peak	238	2.0	
285.274	31.5	V	46.0	-14.5	Peak	95	1.0	
391.699	40.0	H	46.0	-6.0	Peak	188	1.0	

Maximized quasi-peak readings (includes manipulation of EUT interface cables)

Frequency	Level	Pol	FCC 15.209 / RSS 210		Detector	Azimuth	Height	Comments
MHz	dBuV/m	v/h	Limit	Margin	Pk/QP/Avg	degrees	meters	
200.008	30.2	H	43.5	-13.3	QP	218	1.5	QP (1.00s)
160.029	29.2	H	43.5	-14.3	QP	205	1.6	QP (1.00s)
89.727	27.5	H	43.5	-16.0	QP	75	2.2	QP (1.00s)
391.699	29.6	H	46.0	-16.4	QP	186	1.0	QP (1.00s)
133.637	21.9	V	43.5	-21.6	QP	191	1.0	QP (1.00s)
216.011	23.0	H	46.0	-23.0	QP	219	1.6	QP (1.00s)

Client:	Intel Corporation	Job Number:	J80397
Model:	Intel® Centrino® Wireless-N 1030 and Intel® Centrino® Wireless-N 130	T-Log Number:	T80458
		Account Manager:	Christine Krebill
Contact:	Steve Hackett		
Standard:	FCC.247, RSS-210 Issue 7	Class:	N/A

RSS 210 and FCC 15.247 (DSS) Radiated Spurious Emissions Bluetooth - Transmitter and Receiver Mode

Summary of Results - Device Operating in the 2400-2483.5 MHz Band

Record results for target power and also for the passing power if it fails at target.

For Bluetooth: Tx is chain B, Rx is chain B

Bluetooth uses a frequency hopping algorithm that means that the device, during normal operation, is only on a specific channel for a short period of time. The average correction factor is calculated as follows:

A maximum length packet has a duration of 5 time slots.

The hopping rate is 1600 hops/second so the maximum dwell time is 5/1600 seconds, or 3.125ms.

With a minimum of 20 hopping channels a channel will not be used more than 4 times in any 100ms period.

The maximum dwell time in a 100m period is $4 \times 3.125\text{ms} = 12.5\text{ms}$.

The average correction factor is, therefore, $20\log(12.5/100) = -18\text{dB}$

As this is a hopping radio the correction factor can be applied to the average value of the signal provided the average value was measured with the device continuously transmitting. DA 00-0705 permits the use of the average correction on the **measured average** value for frequency hopping radios.

Run #	Mode	Channel	Target Power	Measured Power	Test Performed	Limit	Result / Margin
1a	Bluetooth basic rate (1Mb/s)	2402	7dBm	6.4dBm	Restricted Band Edge (2390 MHz)	FCC Part 15.209 / 15.247(c)	47.9dBµV/m @ 2362.1MHz (-6.1dB)
					Radiated Emissions, 1 - 26 GHz	FCC Part 15.209 / 15.247(c)	37.8dBµV/m @ 1329.1MHz (-16.2dB)
1b		2440	7dBm	7.0dBm	Radiated Emissions, 1 - 26 GHz	FCC Part 15.209 / 15.247(c)	32.8dBµV/m @ 1331.2MHz (-21.2dB)
1c		2480	7dBm	7.0dBm	Restricted Band Edge (2483.5 MHz)	FCC Part 15.209 / 15.247(c)	61.5dBµV/m @ 2483.7MHz (-12.5dB)
					Radiated Emissions, 1 - 26 GHz	FCC Part 15.209 / 15.247(c)	37.5dBµV/m @ 7507.7MHz (-16.5dB)
2a		Bluetooth EDR (3 Mb/s)	2402	7dBm	0.3dBm	Restricted Band Edge (2390 MHz)	FCC Part 15.209 / 15.247(c)
Radiated Emissions, 1 - 26 GHz	FCC Part 15.209 / 15.247(c)					36.2dBµV/m @ 1328.6MHz (-17.8dB)	
2b	2440		7dBm	2.3dBm	Radiated Emissions, 1 - 26 GHz	FCC Part 15.209 / 15.247(c)	36.7dBµV/m @ 1327.4MHz (-17.3dB)
2c	2480	7dBm	2.4dBm	Restricted Band Edge (2483.5 MHz)	FCC Part 15.209 / 15.247(c)	52.0dBµV/m @ 2483.5MHz (-2.0dB)	
				Radiated Emissions, 1 - 26 GHz	FCC Part 15.209 / 15.247(c)	38.3dBµV/m @ 1328.2MHz (-15.7dB)	
3	Bluetooth Receive	2440	-	-	Radiated Emissions, 1 - 7.5 GHz	RSS 210	41.7dBµV/m @ 1331.2MHz (-12.3dB)

Client:	Intel Corporation	Job Number:	J80397
Model:	Intel® Centrino® Wireless-N 1030 and Intel® Centrino® Wireless-N 130	T-Log Number:	T80458
		Account Manager:	Christine Krebill
Contact:	Steve Hackett		
Standard:	FCC.247, RSS-210 Issue 7	Class:	N/A

Test Specific Details

Objective: The objective of this test session is to perform final qualification testing of the EUT with respect to the specification listed above.

General Test Configuration

The EUT and all local support equipment were located on the turntable for radiated spurious emissions testing. For radiated emissions testing the measurement antenna was located 3 meters from the EUT.

Ambient Conditions:

Temperature: 20-25 °C
 Rel. Humidity: 40-50 %

Modifications Made During Testing

No modifications were made to the EUT during testing

Deviations From The Standard

No deviations were made from the requirements of the standard.

Device Information:

WFM: 00150079C6BF
DRTU Version: 1.2.2-0177
Driver Version: 14.0.0.39
Board Voltage: 3.31VDC

Client:	Intel Corporation	Job Number:	J80397
Model:	Intel® Centrino® Wireless-N 1030 and Intel® Centrino® Wireless-N 130	T-Log Number:	T80458
Contact:	Steve Hackett	Account Manager:	Christine Krebill
Standard:	FCC.247, RSS-210 Issue 7	Class:	N/A

Run #1: Radiated Spurious Emissions, 1000-26000 MHz. Operating Mode: Basic data rate (1Mb/s)

Date of Test: 9/8/2010 Test Location: Chamber #5
 Test Engineer: M. Birgani

Run #1a: Low Channel @ 2402 MHz

Chain B	Target (dBm)	Power Settings Measured (dBm)	Software Setting
	7.0	6.4	DH5 - 8.0

Fundamental Signal Field Strength: Peak value measured in 100kHz

Frequency	Level	Pol	15.209 / 15.247		Detector	Azimuth	Height	Comments
MHz	dBµV/m	V/H	Limit	Margin	Pk/QP/Avg	degrees	meters	
2402.050	101.4	H	-	-	-	321	1.0	RB = VB = 100kHz
2402.040	100.3	V	-	-	-	351	1.0	RB = VB = 100kHz

Fundamental emission level @ 3m in 100kHz RBW:	101.4 dBµV/m	Limit is -20dBc (Peak power measurement)
Limit for emissions outside of restricted bands:	81.4 dBµV/m	

Band Edge Signal Field Strength - Direct measurement of field strength

Frequency	Level	Pol	15.209 / 15.247		Detector	Azimuth	Height	Comments
MHz	dBµV/m	V/H	Limit	Margin	Pk/QP/Avg	degrees	meters	
2362.070	47.9	H	54.0	-6.1	AVG	321	1.0	
2388.130	58.8	H	74.0	-15.2	PK	321	1.0	
2362.200	47.7	V	54.0	-6.3	AVG	351	1.0	
2360.800	58.8	V	74.0	-15.2	PK	351	1.0	

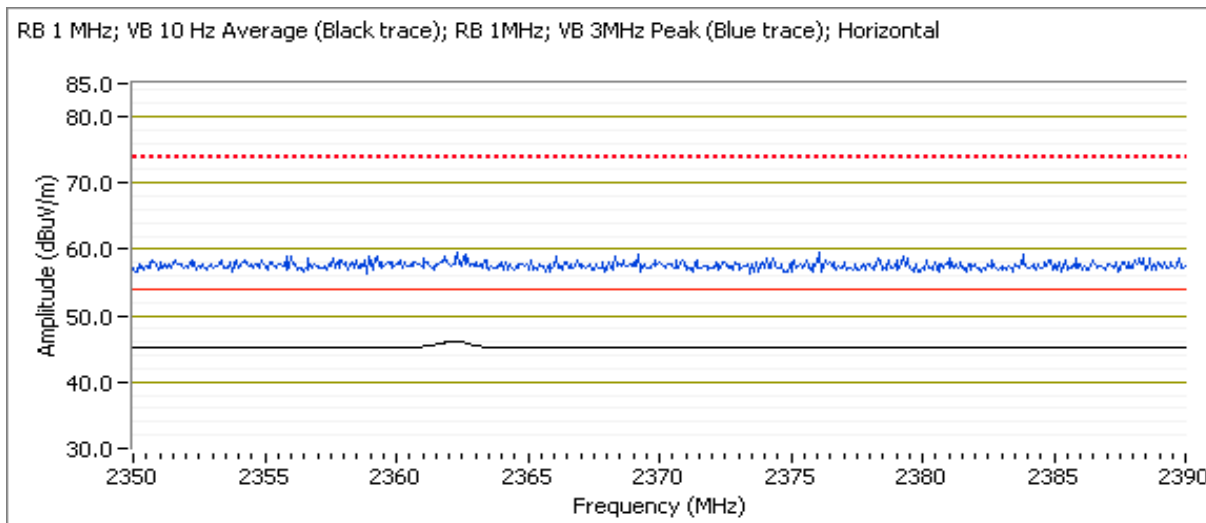

Client:	Intel Corporation	Job Number:	J80397
Model:	Intel® Centrino® Wireless-N 1030 and Intel® Centrino® Wireless-N 130	T-Log Number:	T80458
Contact:	Steve Hackett	Account Manager:	Christine Krebill
Standard:	FCC.247, RSS-210 Issue 7	Class:	N/A

Other Spurious Emissions

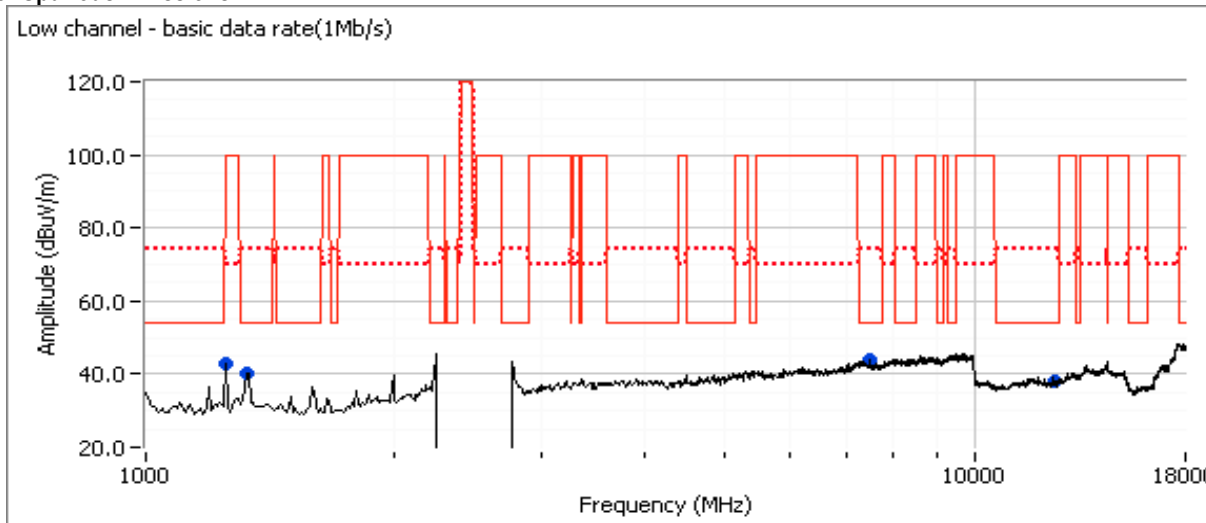

Frequency	Level	Pol	15.209 / 15.247	Detector	Azimuth	Height	Comments	
MHz	dBuV/m	V/H	Limit	Margin	Pk/QP/Avg	degrees	meters	
1329.090	37.8	V	54.0	-16.2	AVG	111	1.9	RB 1 MHz;VB 10 Hz;Pk
7491.340	37.7	V	54.0	-16.3	AVG	111	1.9	RB 1 MHz;VB 10 Hz;Pk
1329.530	56.4	V	74.0	-17.6	PK	111	1.9	RB 1 MHz;VB 3 MHz;Pk
12486.080	32.0	H	54.0	-22.0	AVG	158	2.2	RB 1 MHz;VB 10 Hz;Pk
7492.660	49.3	V	74.0	-24.7	PK	111	1.9	RB 1 MHz;VB 3 MHz;Pk
1250.250	43.3	V	70.0	-26.7	PK	124	1.0	RB 1 MHz;VB 3 MHz;Pk
12487.350	43.4	H	74.0	-30.6	PK	158	2.2	RB 1 MHz;VB 3 MHz;Pk
1249.790	26.4	V	100.0	-73.6	AVG	124	1.0	RB 1 MHz;VB 10 Hz;Pk

Note 1: For emissions in restricted bands, the limit of 15.209 was used. For all other emissions, the limit was set 20dB below the level of the fundamental and measured in 100kHz.

Note 3: Scans made between 18 - 26GHz with the measurement antenna moved around the card and its antennas 20-50cm from the device indicated there were no significant emissions in this frequency range

Client:	Intel Corporation	Job Number:	J80397
Model:	Intel® Centrino® Wireless-N 1030 and Intel® Centrino® Wireless-N 130	T-Log Number:	T80458
		Account Manager:	Christine Krebill
Contact:	Steve Hackett		
Standard:	FCC.247, RSS-210 Issue 7	Class:	N/A

Run #1b: Center Channel @ 2440 MHz

	Target (dBm)	Power Settings Measured (dBm)	Software Setting
Chain B	7.0	7.0	DH5 - 8.0

Fundamental Signal Field Strength: Peak value measured in 100kHz

Frequency	Level	Pol	15.209 / 15.247		Detector	Azimuth	Height	Comments
MHz	dB μ V/m	V/H	Limit	Margin	Pk/QP/Avg	degrees	meters	
2440.020	101.1	H	-	-	-	233	1.0	RB = VB = 100kHz
2440.030	98.9	V	-	-	-	6	1.8	RB = VB = 100kHz

Fundamental emission level @ 3m in 100kHz RBW:	101.1 dB μ V/m	
Limit for emissions outside of restricted bands:	81.1 dB μ V/m	Limit is -20dBc (Peak power measurement)

Other Spurious Emissions

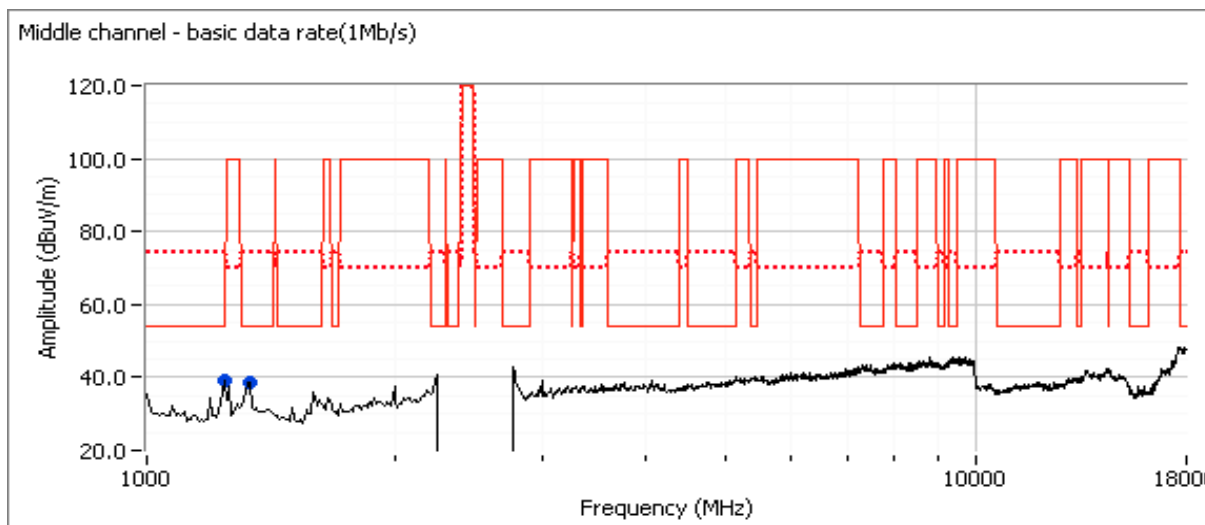

Frequency	Level	Pol	15.209 / 15.247		Detector	Azimuth	Height	Comments
MHz	dB μ V/m	V/H	Limit	Margin	Pk/QP/Avg	degrees	meters	
1331.190	32.8	V	54.0	-21.2	AVG	84	1.3	MHz;VB 10 Hz;Pk
1331.690	51.8	V	74.0	-22.2	PK	84	1.3	MHz;VB 3 MHz;Pk
1240.960	36.6	V	70.0	-33.4	PK	145	2.5	MHz;VB 3 MHz;Pk
1240.770	25.1	V	100.0	-74.9	AVG	145	2.5	MHz;VB 10 Hz;Pk

- Note 1: For emissions in restricted bands, the limit of 15.209 was used. For all other emissions, the limit was set 20dB below the level of the fundamental and measured in 100kHz.
- Note 2: Average measurement corrected using the -18dB correction factor for hopping.
- Note 3: Scans made between 18 - 26GHz with the measurement antenna moved around the card and its antennas 20-50cm from the device indicated there were no significant emissions in this frequency range

Client:	Intel Corporation	Job Number:	J80397
Model:	Intel® Centrino® Wireless-N 1030 and Intel® Centrino® Wireless-N 130	T-Log Number:	T80458
Contact:	Steve Hackett	Account Manager:	Christine Krebill
Standard:	FCC.247, RSS-210 Issue 7	Class:	N/A

Run #1c: High Channel @ 2480 MHz

	Target (dBm)	Power Settings Measured (dBm)	Software Setting
Chain B	7.0	7.0	DH5 - 8.0

Fundamental Signal Field Strength: Peak value measured in 100kHz

Frequency	Level	Pol	15.209 / 15.247		Detector	Azimuth	Height	Comments
MHz	dB μ V/m	V/H	Limit	Margin	Pk/QP/Avg	degrees	meters	
2480.020	101.1	H	-	-	-	320	1.0	RB = VB = 100kHz
2480.180	99.0	V	-	-	-	11	1.0	RB = VB = 100kHz

Fundamental emission level @ 3m in 100kHz RBW :	101.1 dB μ V/m	Limit is -20dBc (Peak power measurement)
Limit for emissions outside of restricted bands:	81.1 dB μ V/m	

Band Edge Signal Field Strength - Direct measurement of field strength

Frequency	Level	Pol	15.209 / 15.247		Detector	Azimuth	Height	Comments
MHz	dB μ V/m	V/H	Limit	Margin	Pk/QP/Avg	degrees	meters	
2483.720	61.5	H	74.0	-12.5	PK	320	1.0	
2483.580	60.7	V	74.0	-13.3	PK	11	1.0	
2483.500	35.8	H	54.0	-18.2	AVG	320	1.0	Measured value = 53.8dB μ V/m
2483.500	33.9	V	54.0	-20.1	AVG	11	1.0	Measured value = 51.9dB μ V/m

Note 2: Average measurement corrected using the -18dB correction factor for hopping.

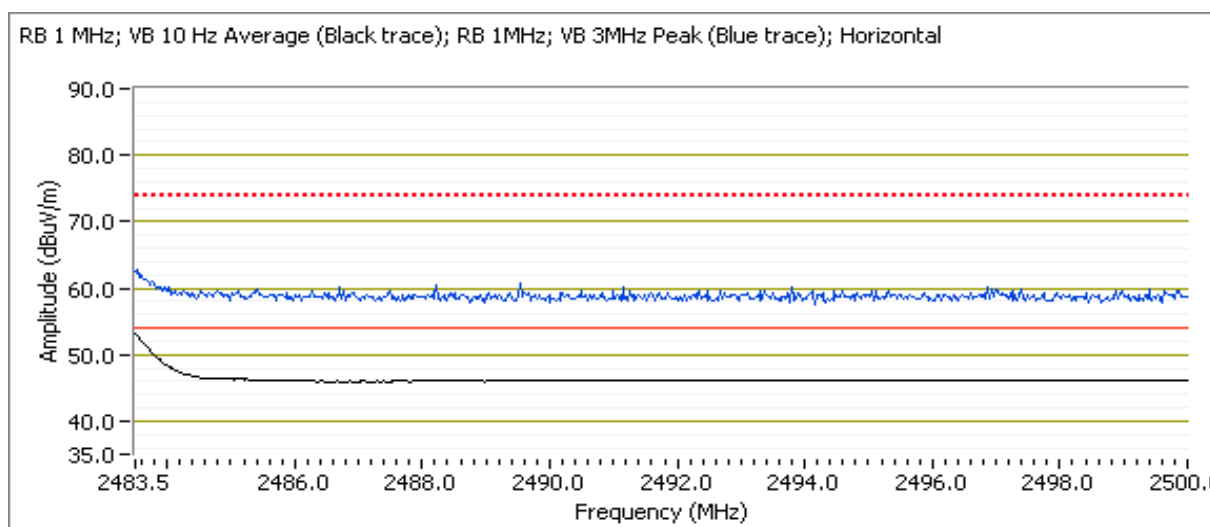

Client:	Intel Corporation	Job Number:	J80397
Model:	Intel® Centrino® Wireless-N 1030 and Intel® Centrino® Wireless-N 130	T-Log Number:	T80458
		Account Manager:	Christine Krebill
Contact:	Steve Hackett		
Standard:	FCC.247, RSS-210 Issue 7	Class:	N/A

Other Spurious Emissions

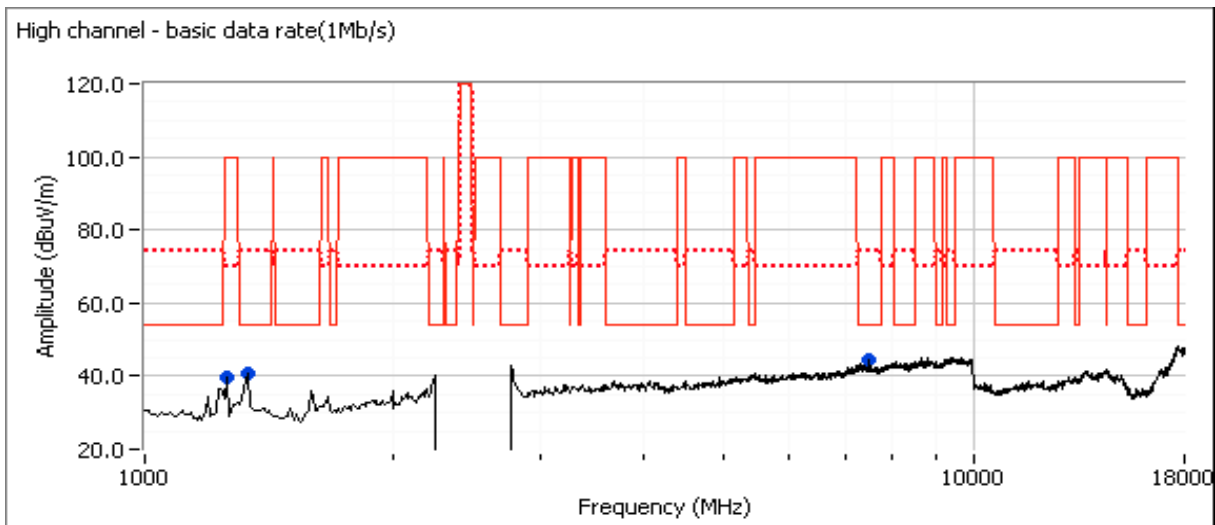

Frequency	Level	Pol	15.209 / 15.247		Detector	Azimuth	Height	Comments
MHz	dBuV/m	V/H	Limit	Margin	Pk/QP/Avg	degrees	meters	
7507.730	37.5	V	54.0	-16.5	AVG	84	1.6	MHz;VB 10 Hz;Pk
1333.750	35.2	V	54.0	-18.8	AVG	94	1.3	MHz;VB 10 Hz;Pk
1247.690	49.0	V	70.0	-21.0	PK	165	1.0	MHz;VB 3 MHz;Pk
7508.830	50.5	V	74.0	-23.5	PK	84	1.6	MHz;VB 3 MHz;Pk
1336.000	49.1	V	74.0	-24.9	PK	94	1.3	MHz;VB 3 MHz;Pk
1248.190	28.7	V	100.0	-71.3	AVG	165	1.0	MHz;VB 10 Hz;Pk

- Note 1: For emissions in restricted bands, the limit of 15.209 was used. For all other emissions, the limit was set 20dB below the level of the fundamental and measured in 100kHz.
- Note 3: Scans made between 18 - 26GHz with the measurement antenna moved around the card and its antennas 20-50cm from the device indicated there were no significant emissions in this frequency range

Client:	Intel Corporation	Job Number:	J80397
Model:	Intel® Centrino® Wireless-N 1030 and Intel® Centrino® Wireless-N 130	T-Log Number:	T80458
		Account Manager:	Christine Krebill
Contact:	Steve Hackett		
Standard:	FCC.247, RSS-210 Issue 7	Class:	N/A

Run #2: Radiated Spurious Emissions, 1000-26000 MHz. Operating Mode: Extended data rate (3Mb/s)

Date of Test: 9/8/2010

Test Location: FT Chamber #5

Test Engineer: Joseph Cadigal/R. Varelas

Run #2a: Low Channel @ 2402 MHz

Chain B	Target (dBm)	Power Settings Measured (dBm)	Software Setting
		7.0	0.3

Fundamental Signal Field Strength: Peak value measured in 100kHz

Frequency	Level	Pol	15.209 / 15.247		Detector	Azimuth	Height	Comments
MHz	dBμV/m	V/H	Limit	Margin	Pk/QP/Avg	degrees	meters	
2402.150	97.2	H	-	-	-	245	1.0	RB = VB = 100kHz
2402.150	95.3	V	-	-	-	20	1.0	RB = VB = 100kHz

Fundamental emission level @ 3m in 100kHz RBW:	97.2 dBμV/m	
Limit for emissions outside of restricted bands:	77.2 dBμV/m	Limit is -20dBc (Peak power measurement)

Band Edge Signal Field Strength - Direct measurement of field strength

Frequency	Level	Pol	15.209 / 15.247		Detector	Azimuth	Height	Comments
MHz	dBμV/m	V/H	Limit	Margin	Pk/QP/Avg	degrees	meters	
2362.270	47.1	H	54.0	-6.9	AVG	245	1.0	
2354.000	47.0	V	54.0	-7.0	AVG	20	1.0	
2381.470	59.0	H	74.0	-15.0	PK	245	1.0	
2358.130	58.8	V	74.0	-15.2	PK	20	1.0	

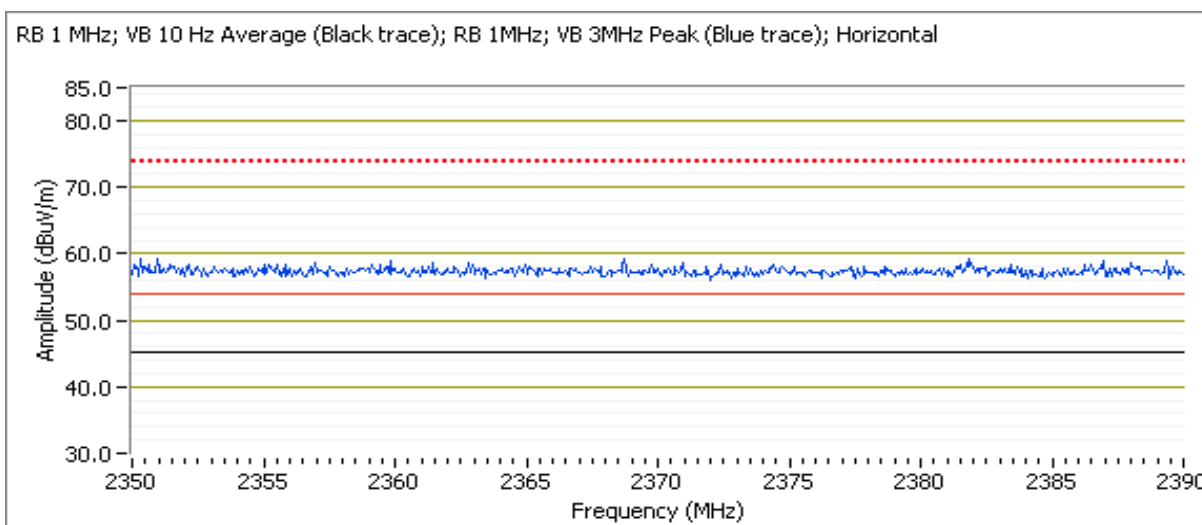

Client:	Intel Corporation	Job Number:	J80397
Model:	Intel® Centrino® Wireless-N 1030 and Intel® Centrino® Wireless-N 130	T-Log Number:	T80458
		Account Manager:	Christine Krebill
Contact:	Steve Hackett		
Standard:	FCC.247, RSS-210 Issue 7	Class:	N/A

Other Spurious Emissions

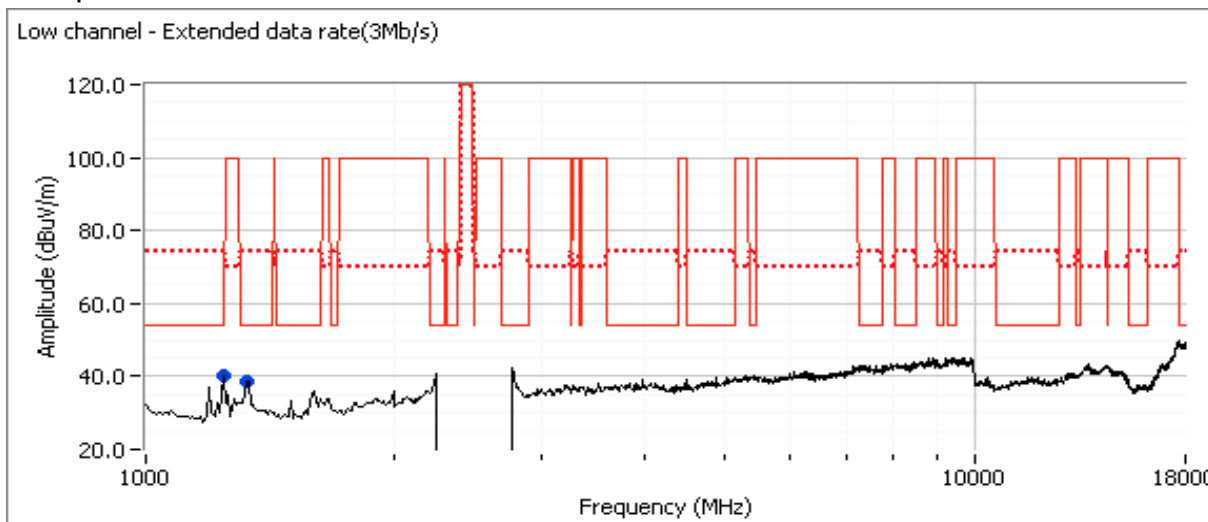

Frequency	Level	Pol	15.209 / 15.247		Detector	Azimuth	Height	Comments
MHz	dBµV/m	V/H	Limit	Margin	Pk/QP/Avg	degrees	meters	
1328.600	36.2	V	54.0	-17.8	AVG	75	1.0	MHz;VB 10 Hz;Pk
1326.360	52.8	V	74.0	-21.2	PK	75	1.0	MHz;VB 3 MHz;Pk
1227.490	27.2	V	54.0	-26.8	AVG	346	1.2	MHz;VB 10 Hz;Pk
1233.460	42.5	V	74.0	-31.5	PK	346	1.2	MHz;VB 3 MHz;Pk

Note 1: For emissions in restricted bands, the limit of 15.209 was used. For all other emissions, the limit was set 20dB below the level of the fundamental and measured in 100kHz.

Note 3: Scans made between 18 - 26GHz with the measurement antenna moved around the card and its antennas 20-50cm from the device indicated there were no significant emissions in this frequency range

Client:	Intel Corporation	Job Number:	J80397
Model:	Intel® Centrino® Wireless-N 1030 and Intel® Centrino® Wireless-N 130	T-Log Number:	T80458
		Account Manager:	Christine Krebill
Contact:	Steve Hackett		
Standard:	FCC.247, RSS-210 Issue 7	Class:	N/A

Run #2b: Center Channel @ 2440 MHz

	Target (dBm)	Power Settings Measured (dBm)	Software Setting
Chain B	7.0	2.3	3-DH5 - 8.0

Fundamental Signal Field Strength: Peak value measured in 100kHz

Frequency	Level	Pol	15.209 / 15.247		Detector	Azimuth	Height	Comments
MHz	dBμV/m	V/H	Limit	Margin	Pk/QP/Avg	degrees	meters	
2440.130	97.1	H	-	-	-	314	1.0	kHz;VB 100 kHz;Pk
2440.170	94.6	V	-	-	-	20	1.0	kHz;VB 100 kHz;Pk

Fundamental emission level @ 3m in 100kHz RBW:	97.1 dBμV/m	Limit is -20dBc (Peak power measurement)
Limit for emissions outside of restricted bands:	77.1 dBμV/m	

Frequency	Level	Pol	15.209 / 15.247		Detector	Azimuth	Height	Comments
MHz	dBμV/m	V/H	Limit	Margin	Pk/QP/Avg	degrees	meters	
1327.430	36.7	V	54.0	-17.3	AVG	191	1.0	MHz;VB 10 Hz;Pk
1594.310	33.1	V	54.0	-20.9	AVG	174	1.2	MHz;VB 10 Hz;Pk
1325.100	50.0	V	74.0	-24.0	PK	191	1.0	MHz;VB 3 MHz;Pk
1594.370	45.9	V	74.0	-28.1	PK	174	1.2	MHz;VB 3 MHz;Pk

Note 1: For emissions in restricted bands, the limit of 15.209 was used. For all other emissions, the limit was set 20dB below the level of the fundamental and measured in 100kHz.

Note 3: Scans made between 18 - 26GHz with the measurement antenna moved around the card and its antennas 20-50cm from the device indicated there were no significant emissions in this frequency range

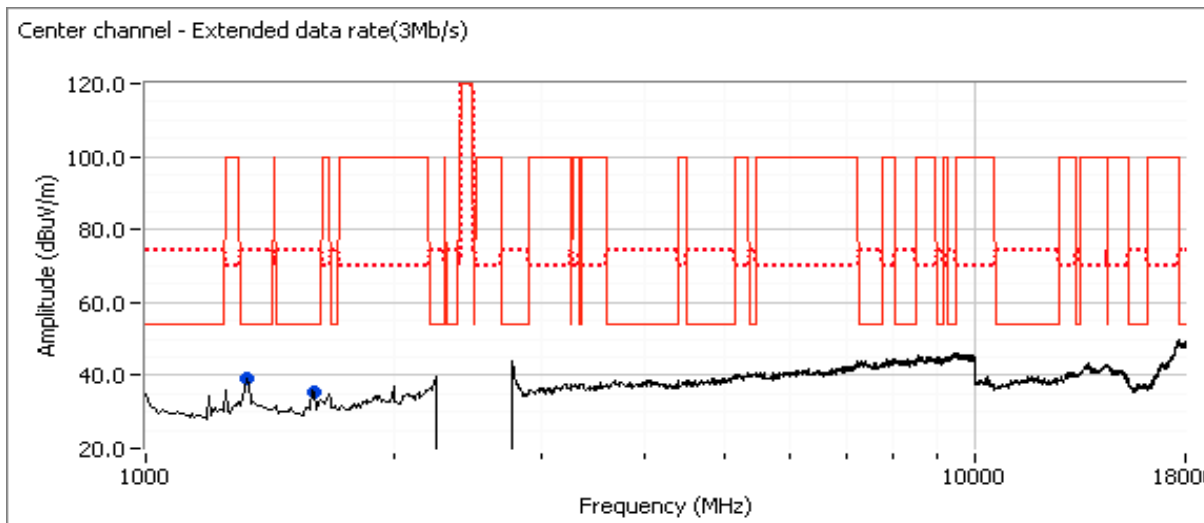

Client:	Intel Corporation	Job Number:	J80397
Model:	Intel® Centrino® Wireless-N 1030 and Intel® Centrino® Wireless-N 130	T-Log Number:	T80458
		Account Manager:	Christine Krebill
Contact:	Steve Hackett		
Standard:	FCC.247, RSS-210 Issue 7	Class:	N/A

Run #2c: High Channel @ 2480 MHz

	Target (dBm)	Power Settings Measured (dBm)	Software Setting
Chain B	7.0	2.4	3-DH5 - 8.0

Fundamental Signal Field Strength: Peak value measured in 100kHz

Frequency	Level	Pol	15.209 / 15.247		Detector	Azimuth	Height	Comments
MHz	dB μ V/m	V/H	Limit	Margin	Pk/QP/Avg	degrees	meters	
2480.170	98.1	H	-	-	-	319	1.0	RB = VB = 100kHz
2480.080	96.7	V	-	-	-	18	1.8	RB = VB = 100kHz

Fundamental emission level @ 3m in 100kHz RBW :	98.1 dB μ V/m	Limit is -20dBc (Peak power measurement)
Limit for emissions outside of restricted bands:	78.1 dB μ V/m	

Band Edge Signal Field Strength - Direct measurement of field strength

Frequency	Level	Pol	15.209 / 15.247		Detector	Azimuth	Height	Comments
MHz	dB μ V/m	V/H	Limit	Margin	Pk/QP/Avg	degrees	meters	
2483.500	52.0	H	54.0	-2.0	AVG	319	1.0	
2483.500	51.1	V	54.0	-2.9	AVG	18	1.8	
2483.530	60.8	H	74.0	-13.2	PK	319	1.0	
2483.530	60.5	V	74.0	-13.5	PK	18	1.8	

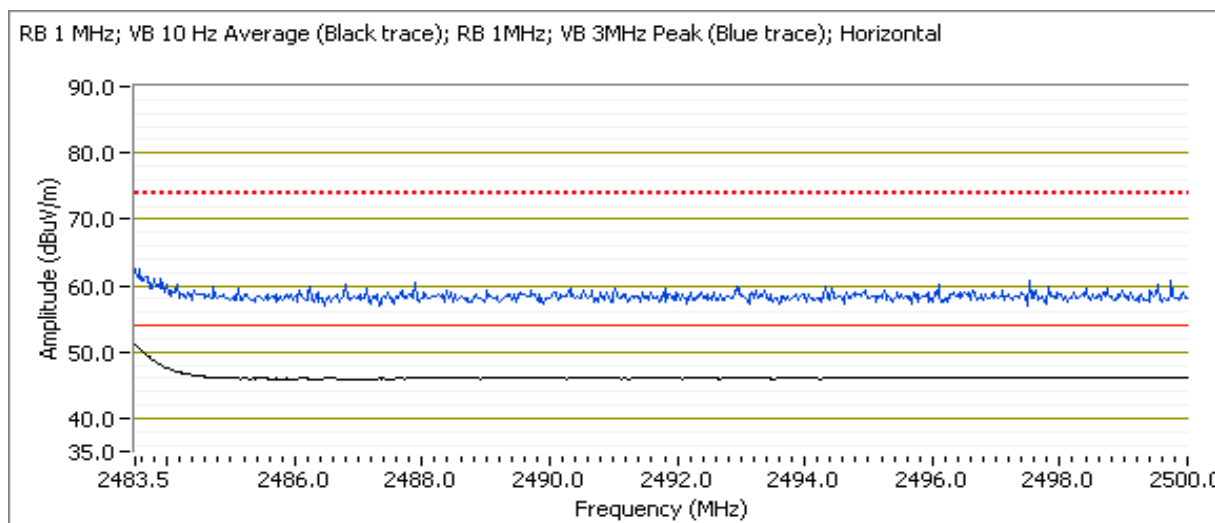

Client:	Intel Corporation	Job Number:	J80397
Model:	Intel® Centrino® Wireless-N 1030 and Intel® Centrino® Wireless-N 130	T-Log Number:	T80458
		Account Manager:	Christine Krebill
Contact:	Steve Hackett		
Standard:	FCC.247, RSS-210 Issue 7	Class:	N/A

Other Spurious Emissions

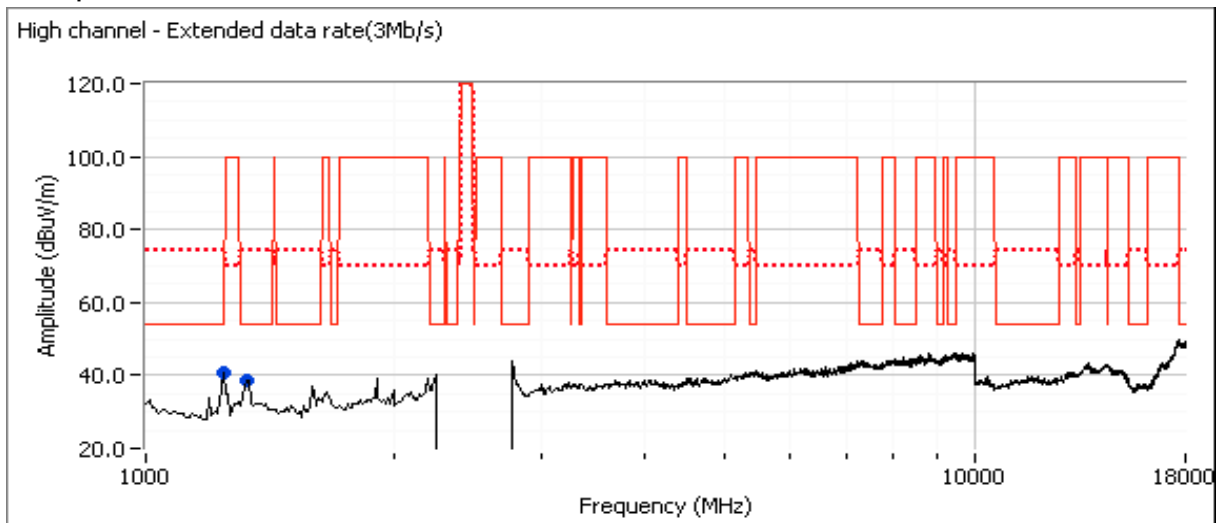

Frequency	Level	Pol	15.209 / 15.247		Detector	Azimuth	Height	Comments
MHz	dBuV/m	V/H	Limit	Margin	Pk/QP/Avg	degrees	meters	
1328.170	38.3	V	54.0	-15.7	AVG	174	1.0	MHz;VB 10 Hz;Pk
1329.170	55.0	V	74.0	-19.0	PK	174	1.0	MHz;VB 3 MHz;Pk
1229.720	26.3	V	54.0	-27.7	AVG	92	2.0	MHz;VB 10 Hz;Pk
1230.160	42.0	V	74.0	-32.0	PK	92	2.0	MHz;VB 3 MHz;Pk

Note 1: For emissions in restricted bands, the limit of 15.209 was used. For all other emissions, the limit was set 20dB below the level of the fundamental and measured in 100kHz.

Note 3: Scans made between 18 - 26GHz with the measurement antenna moved around the card and its antennas 20-50cm from the device indicated there were no significant emissions in this frequency range

Client:	Intel Corporation	Job Number:	J80397
Model:	Intel® Centrino® Wireless-N 1030 and Intel® Centrino® Wireless-N 130	T-Log Number:	T80458
		Account Manager:	Christine Krebill
Contact:	Steve Hackett		
Standard:	FCC.247, RSS-210 Issue 7	Class:	N/A

Run #3: Center Channel @ 2440 MHz, Rx Mode

Frequency MHz	Level dB μ V/m	Pol V/H	15.209 / 15.247		Detector Pk/QP/Avg	Azimuth degrees	Height meters	Comments
			Limit	Margin				
1331.180	41.7	V	54.0	-12.3	AVG	91	1.0	MHz;VB 10 Hz;Pk
2700.030	37.8	V	54.0	-16.2	AVG	57	1.0	MHz;VB 10 Hz;Pk
1993.470	34.6	V	54.0	-19.4	AVG	91	1.1	MHz;VB 10 Hz;Pk
1328.770	54.2	V	74.0	-19.8	PK	91	1.0	MHz;VB 3 MHz;Pk
1992.310	47.5	V	74.0	-26.5	PK	91	1.1	MHz;VB 3 MHz;Pk
2700.150	44.2	V	74.0	-29.8	PK	57	1.0	MHz;VB 3 MHz;Pk

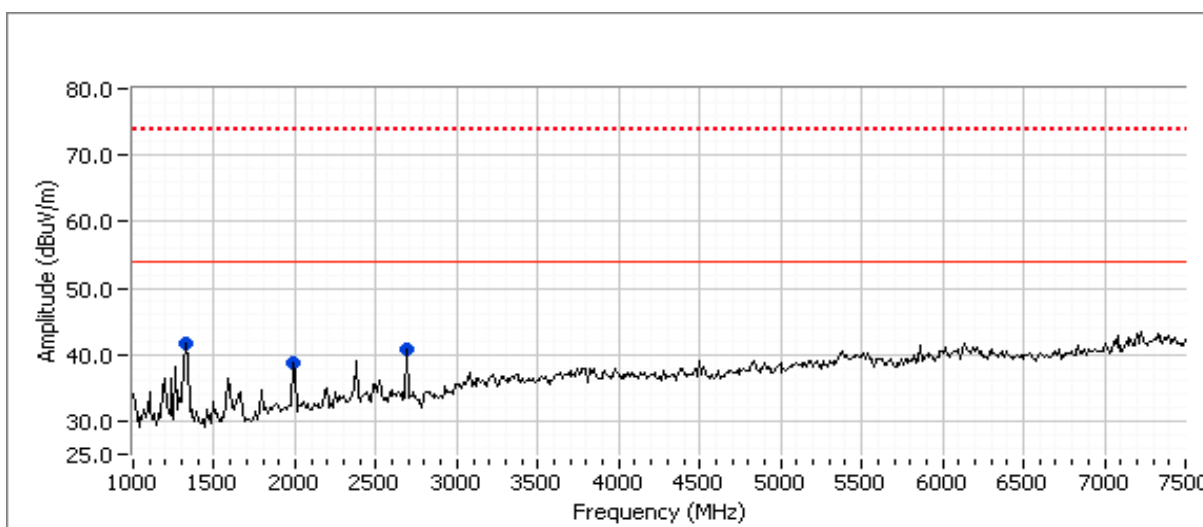

Client:	Intel Corporation	Job Number:	J80397
Model:	Intel® Centrino® Wireless-N 1030 and Intel® Centrino® Wireless-N 130	T-Log Number:	T80458
Contact:	Steve Hackett	Account Manager:	Christine Krebill
Standard:	FCC.247, RSS-210 Issue 7	Class:	N/A

FCC 15.247 FHSS - Power, Bandwidth and Spurious Emissions

Test Specific Details

Objective: The objective of this test session is to perform final qualification testing of the EUT with respect to the specification listed above.

Date of Test: 9/14/2010
 Test Engineer: Rafael Varelas
 Test Location: FT Chamber #4

Config. Used: 1
 Config Change: none
 Host Unit Voltage 120V/60Hz

General Test Configuration

When measuring the conducted emissions from the EUT's antenna port, the antenna port of the EUT was connected to the spectrum analyzer or power meter via a suitable attenuator to prevent overloading the measurement system. All measurements are corrected to allow for the external attenuators used.

Unless stated otherwise the EUT was operating such that it constantly hopped on either the low, center or high channels.

Ambient Conditions:

Temperature: 20.8 °C
 Rel. Humidity: 38 %

Summary of Results

MAC Address: 00150079C6BF DRTU Tool Version 1.2.2-0177 Driver version 14.0.0.39

Run #	Test Performed	Limit	Pass / Fail	Result / Margin
1	Spurious Emissions	15.247(b)	Pass	All emissions below -20dBc
2	Output Power	15.247(b)	Pass	Basic Rate: 7.4 dBm (0.0055 W) EDR: 4.6 dBm (0.0029 W)
3	20dB Bandwidth	15.247(a)	Pass	Basic Rate: 1.108 MHz EDR: 1.367 MHz
3	99% bandwidth	15.247(a)	Pass	Basic Rate: 973 kHz EDR: 1.240 MHz
4	Channel Occupancy	15.247(a)	Pass	Complies with Bluetooth protocol
4	Number of Channels	15.247(a)	Pass	20 - 79 channels

Modifications Made During Testing:

No modifications were made to the EUT during testing

Deviations From The Standard

No deviations were made from the requirements of the standard.

Client:	Intel Corporation	Job Number:	J80397
Model:	Intel® Centrino® Wireless-N 1030 and Intel® Centrino® Wireless-N 130	T-Log Number:	T80458
Contact:	Steve Hackett	Account Manager:	Christine Krebill
Standard:	FCC.247, RSS-210 Issue 7	Class:	N/A

Run #1: Antenna Conducted Spurious Emissions, 30 - 26500 MHz.

Date of Test: 9/14/2010

Test Engineer: Rafael Varelas

Test Location: FT Chamber #4

Refer to plots below. Scans made using RBW=VB=100 KHz with the limit line set at 20dB below the highest in-band signal level.

Basic rate (1Mb/s)

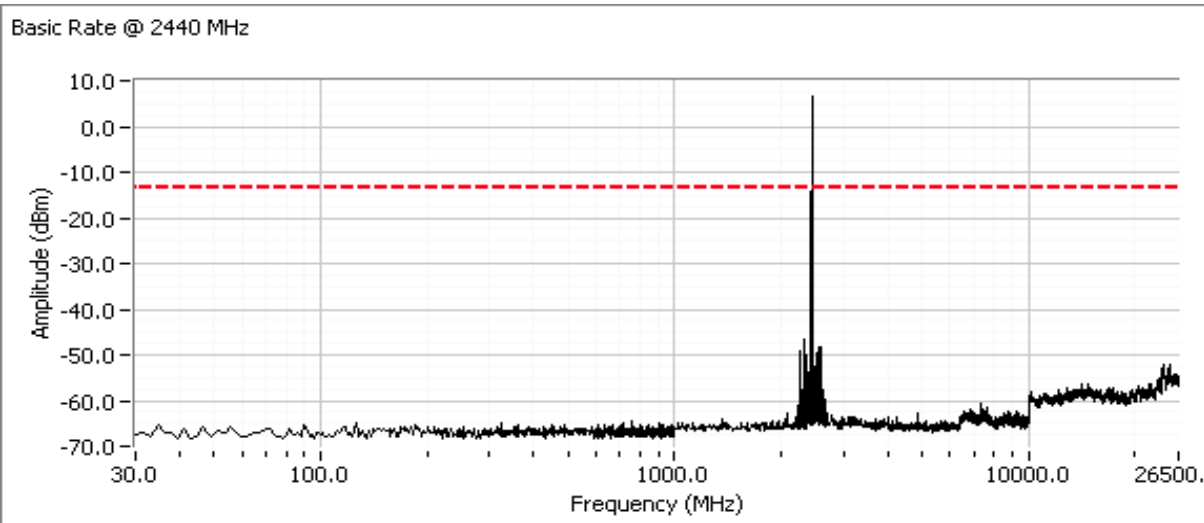
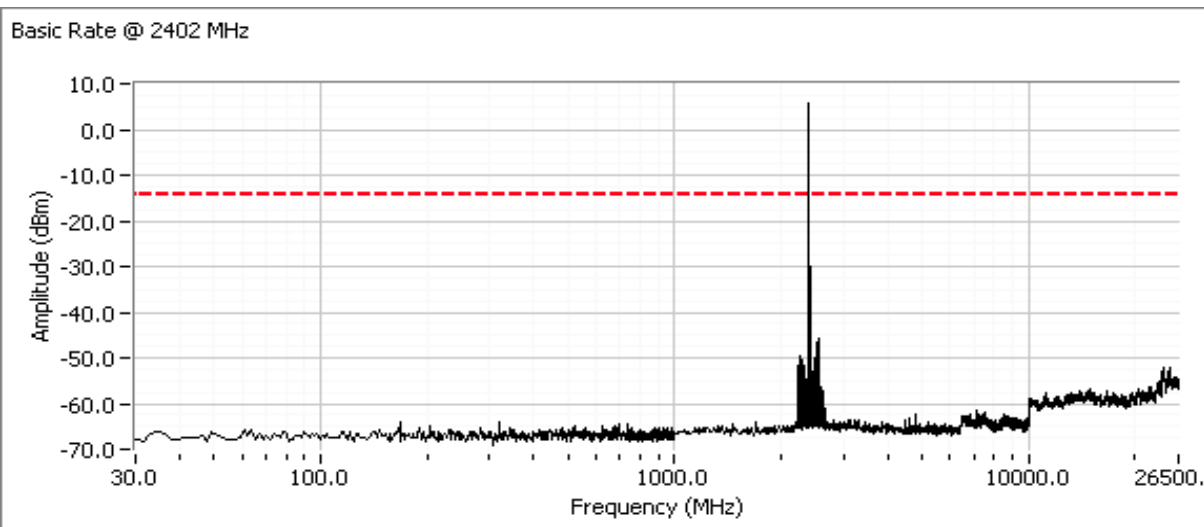

Client:	Intel Corporation	Job Number:	J80397
Model:	Intel® Centrino® Wireless-N 1030 and Intel® Centrino® Wireless-N 130	T-Log Number:	T80458
Contact:	Steve Hackett	Account Manager:	Christine Krebill
Standard:	FCC.247, RSS-210 Issue 7	Class:	N/A

Basic Rate @ 2480 MHz

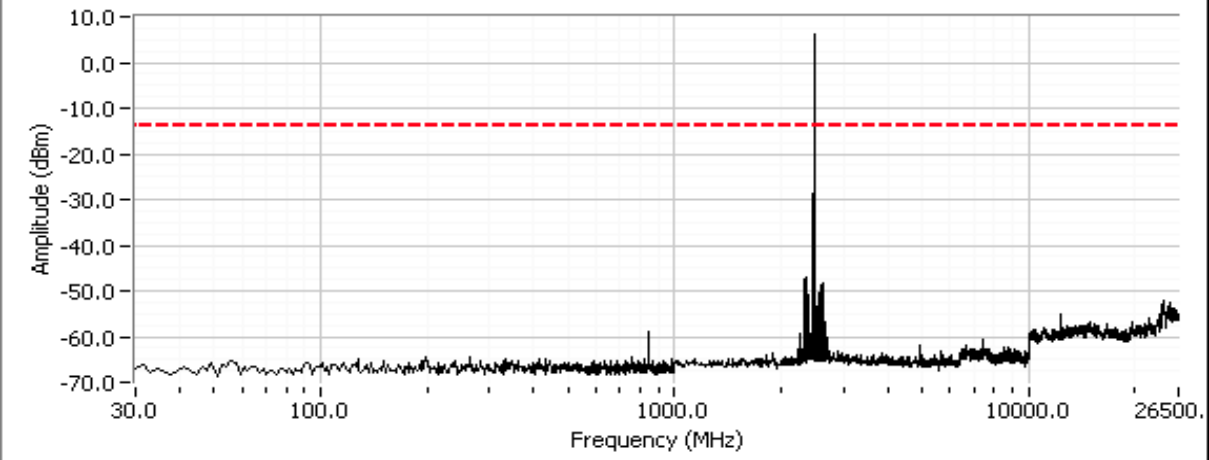

EDR (3Mb/s)

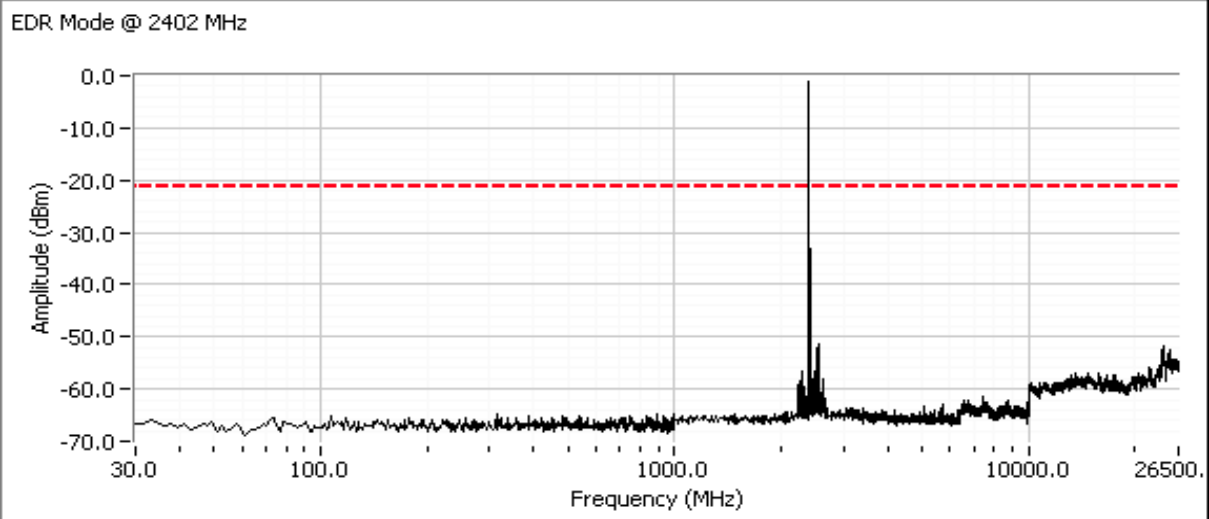

Client:	Intel Corporation	Job Number:	J80397
Model:	Intel® Centrino® Wireless-N 1030 and Intel® Centrino® Wireless-N 130	T-Log Number:	T80458
Contact:	Steve Hackett	Account Manager:	Christine Krebill
Standard:	FCC.247, RSS-210 Issue 7	Class:	N/A

EDR Mode @ 2440 MHz

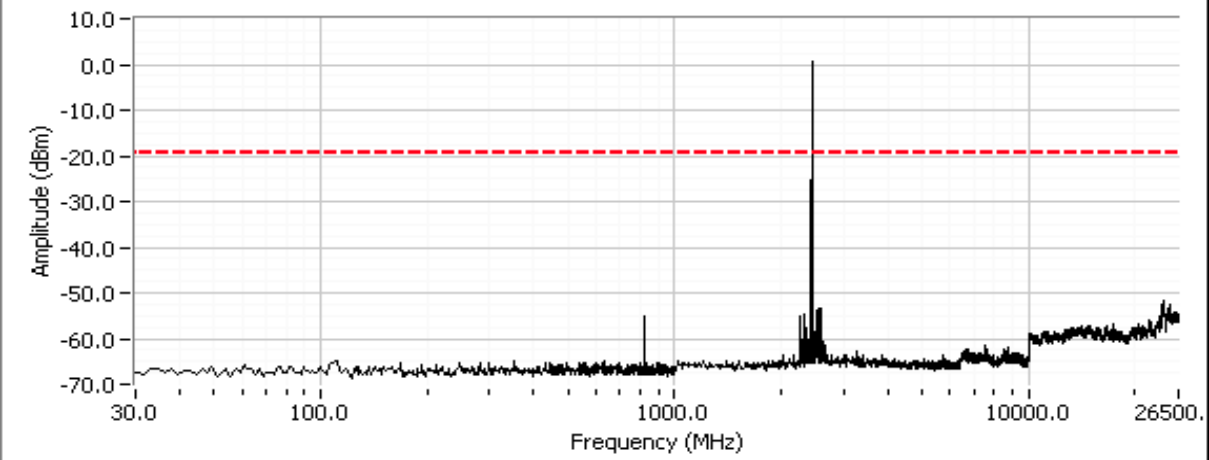

EDR Mode @ 2480 MHz

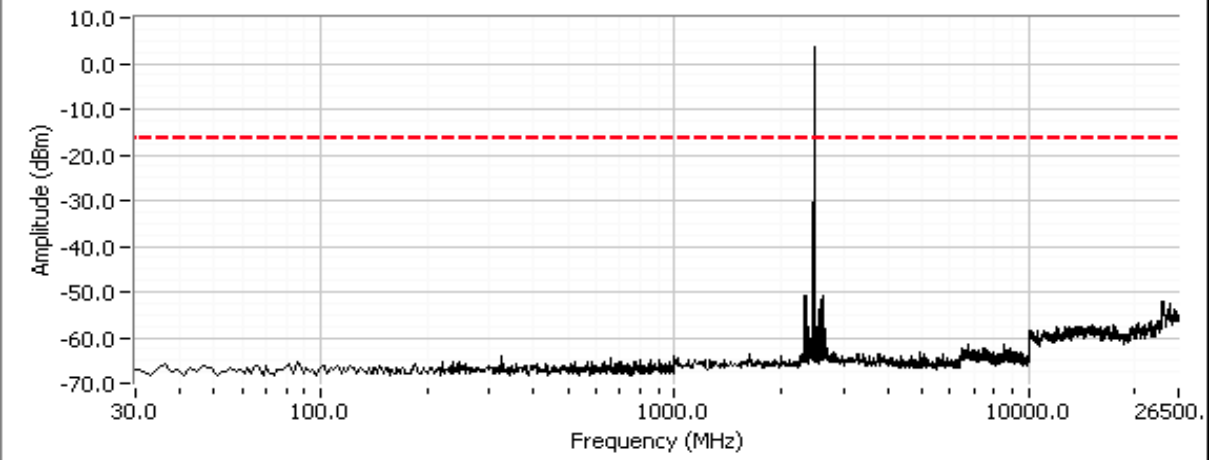

Client:	Intel Corporation	Job Number:	J80397
Model:	Intel® Centrino® Wireless-N 1030 and Intel® Centrino® Wireless-N 130	T-Log Number:	T80458
Contact:	Steve Hackett	Account Manager:	Christine Krebill
Standard:	FCC.247, RSS-210 Issue 7	Class:	N/A

Run #2: Output Power

Date of Test: 9/14/2010

Test Engineer: Rafael Varelas

Test Location: FT Chamber #4

For frequency hopping systems operating in the 2400-2483.5 MHz band employing less than 75 channels or overlapping hopping channels: 0.125 watts.

Maximum antenna gain: 3.2 dBi

Mode	Frequency (MHz)	Setting	Pavg	Output Power (dBm)	Output Power (W)	EIRP (W)
Basic rate	2402	8	6.1	7.0	0.0050	0.010
	2440	8	6.6	7.4	0.0055	0.011
	2480	8	6.6	7.3	0.0054	0.011
EDR (3Mb/s)	2402	8	0.2	2.8	0.0019	0.004
	2440	8	1.6	4.5	0.0028	0.006
	2480	8	2.0	4.6	0.0029	0.006

Note 1:	Output power is measured as a peak power using either a peak power meter or with a spectrum analyzer and VB > 3 x RB and RB > 20dB bandwidth. The actual method used was a peak power meter.
Note 2:	Setting is the test utility software setting and used for reference only. Pavg is the average output power measured with an average power meter and is provided for reference only.

Client:	Intel Corporation	Job Number:	J80397
Model:	Intel® Centrino® Wireless-N 1030 and Intel® Centrino® Wireless-N 130	T-Log Number:	T80458
Contact:	Steve Hackett	Account Manager:	Christine Krebill
Standard:	FCC.247, RSS-210 Issue 7	Class:	N/A

Run #3: Bandwidth and Channel Spacing

Date of Test: 9/14/2010
 Test Engineer: Rafael Varelas
 Test Location: FT Chamber #4

Bandwidth

Mode	Frequency (MHz)	20dB Bandwidth (kHz)	99% Bandwidth (kHz)
Basic rate	2402	1100	957
	2440	1108	973
	2480	1083	973
EDR (3Mb/s)	2402	1358	1230
	2440	1367	1240
	2480	1350	1231

Note 1: 20dB bandwidth measured using RB = 100kHz, VB = 300kHz (VB > RB)
 Note 2: 99% bandwidth measured using RB = 100kHz, VB = 300kHz (VB >= 3RB)

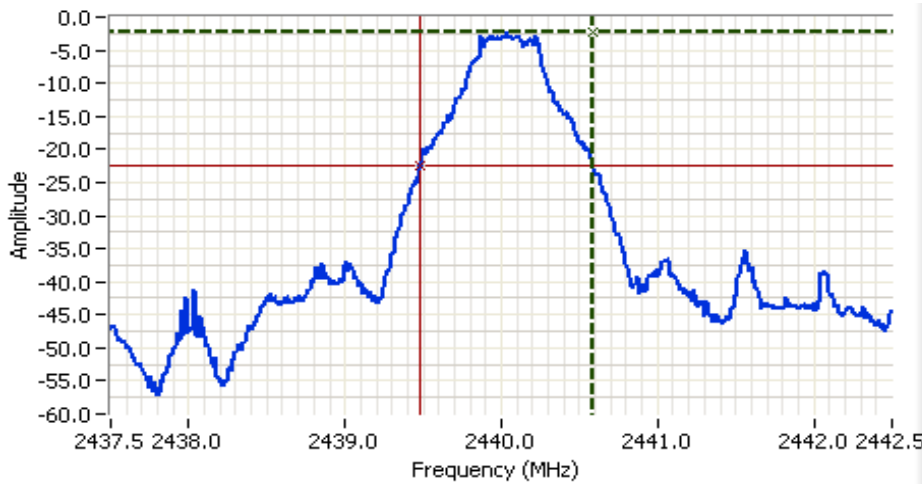

Analyzer Settings
 HP8564E,EMICF: 2440.000 MHz
 SPAN: 5.000 MHz
 RB: 100 kHz
 VB: 300 kHz
 Detector: POS
 Attn: 10 DB
 RL Offset: 0.0 DB
 Sweep Time: 50.0ms
 Ref Lvl: -2.0 DBM

Comments
 20dB BW: 1.108 MHz
 2440 MHz
 Basic rate

Cursor 1 2440.5833 -2.33 
 Cursor 2 2439.4750 -22.33 
 Delta Freq. 1.108
 Delta Amplitude 20.00



Client: Intel Corporation	Job Number: J80397
Model: Intel® Centrino® Wireless-N 1030 and Intel® Centrino® Wireless-N 130	T-Log Number: T80458
Contact: Steve Hackett	Account Manager: Christine Krebill
Standard: FCC.247, RSS-210 Issue 7	Class: N/A

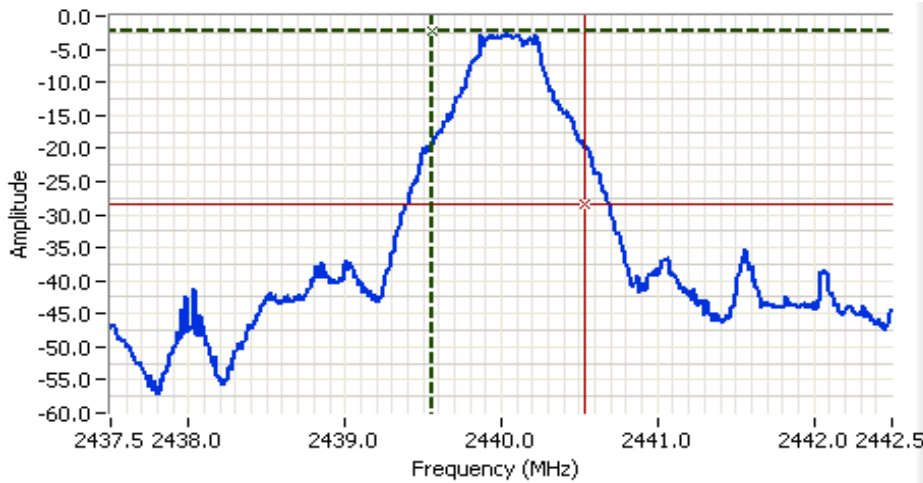

Analyzer Settings
 HP8564E,EMICF: 2440.000 MHz
 SPAN: 5.000 MHz
 RB: 100 kHz
 VB: 300 kHz
 Detector: POS
 Attn: 10 DB
 RL Offset: 0.0 DB
 Sweep Time: 50.0ms
 Ref Lvl: -2.0 DBM

Comments
 99% BW: 973 kHz
 2440 MHz
 Basic rate

Cursor 1 2439.5549 -2.33
 Cursor 2 2440.5283 -28.33

Delta Freq. 973 kHz
 Delta Amplitude 26.00

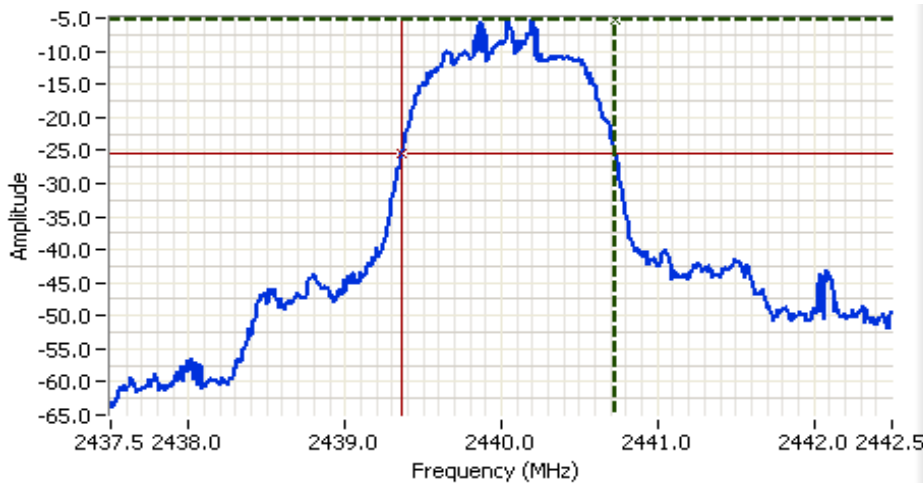

Analyzer Settings
 HP8564E,EMICF: 2440.000 MHz
 SPAN: 5.000 MHz
 RB: 100 kHz
 VB: 300 kHz
 Detector: POS
 Attn: 10 DB
 RL Offset: 0.0 DB
 Sweep Time: 50.0ms
 Ref Lvl: -2.0 DBM

Comments
 20dB BW: 1.367 MHz
 2440 MHz
 EDR Mode

Cursor 1 2440.7333 -5.33
 Cursor 2 2439.3667 -25.33

Delta Freq. 1.367
 Delta Amplitude 20.00



Client: Intel Corporation	Job Number: J80397
Model: Intel® Centrino® Wireless-N 1030 and Intel® Centrino® Wireless-N 130	T-Log Number: T80458
Contact: Steve Hackett	Account Manager: Christine Krebill
Standard: FCC.247, RSS-210 Issue 7	Class: N/A

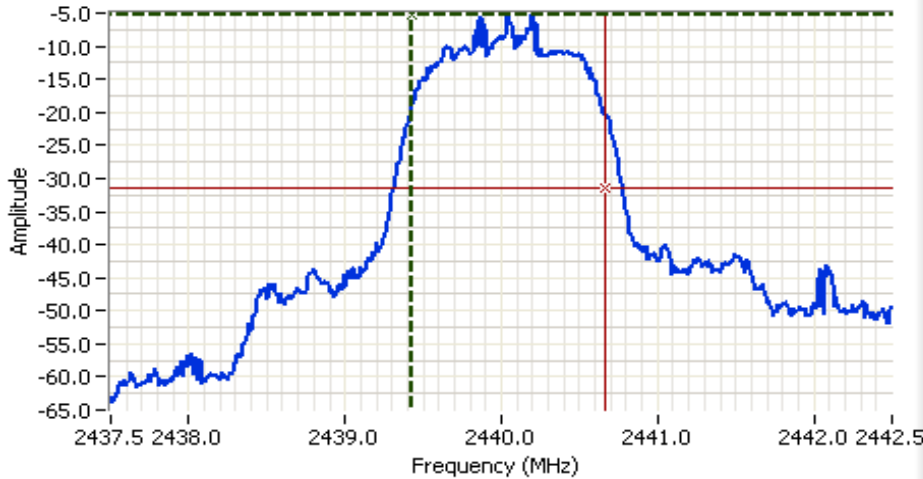

Analyzer Settings
 HP8564E,EMICF: 2440.000 MHz
 SPAN: 5.000 MHz
 RB: 100 kHz
 VB: 300 kHz
 Detector: POS
 Attn: 10 DB
 RL Offset: 0.0 DB
 Sweep Time: 50.0ms
 Ref Lvl: -2.0 DBM

Comments
 99% BW: 1.240 MHz
 2440 MHz
 EDR Mode

Cursor 1 2439.4301 -5.33 Delta Freq. 1.240
 Cursor 2 2440.6697 -31.33 Delta Amplitude 26.00



Channel Spacing / Number of Channels

The channel spacing is 1MHz with a minimum of 20 channels and a maximum of 79 channels used. See plots below showing all 79 channels, with first channel at 2402 MHz and last channel at 2480 MHz

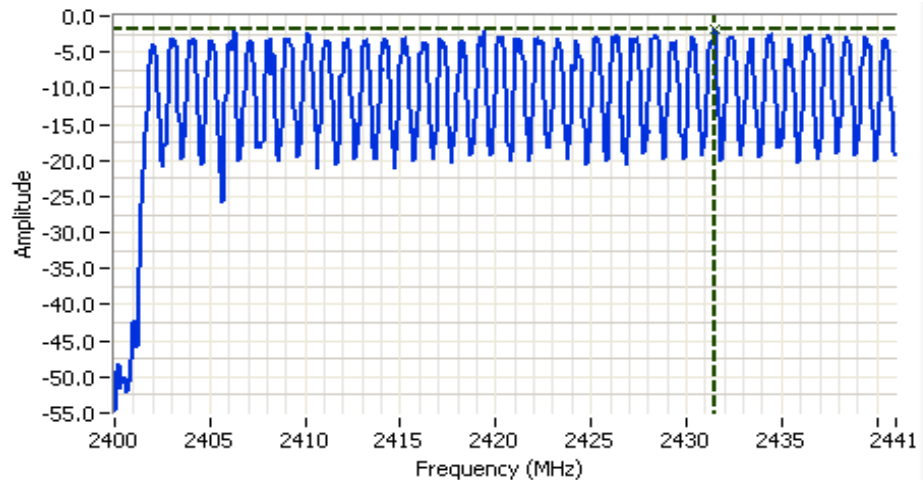

Analyzer Settings
 HP8564E,EMICF: 2420.500 MHz
 SPAN: 41.000 MHz
 RB: 100 kHz
 VB: 300 kHz
 Detector: POS
 Attn: 20 DB
 RL Offset: 0.0 DB
 Sweep Time: 50.0ms
 Ref Lvl: 8.3 DBM

Comments
 Basic Rate Mode
 2400-2441 MHz
 39 Channels

Cursor 1 2431.5017 -1.87
 0.0000 0.00



Client:	Intel Corporation	Job Number:	J80397
Model:	Intel® Centrino® Wireless-N 1030 and Intel® Centrino® Wireless-N 130	T-Log Number:	T80458
Contact:	Steve Hackett	Account Manager:	Christine Krebill
Standard:	FCC.247, RSS-210 Issue 7	Class:	N/A

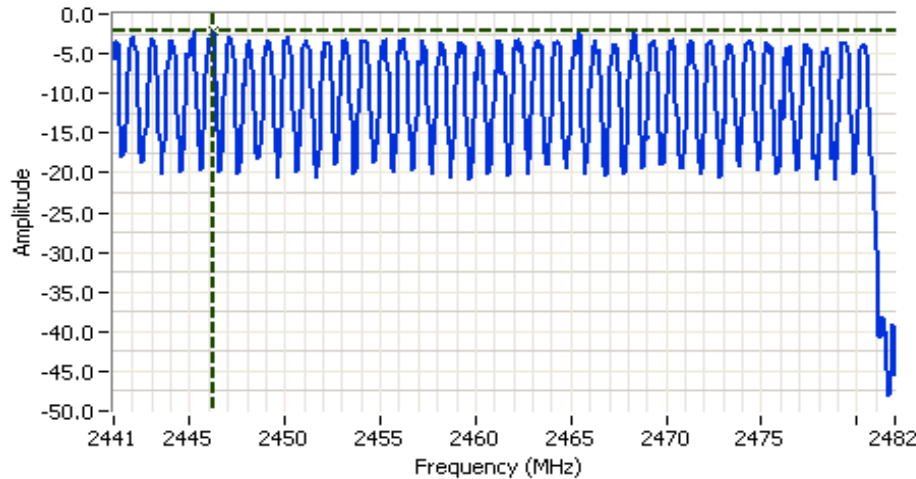

Analyzer Settings
 HP8564E,EMICF: 2461.500 MHz
 SPAN: 41.000 MHz
 RB: 100 kHz
 VB: 300 kHz
 Detector: POS
 Attn: 20 DB
 RL Offset: 0.0 DB
 Sweep Time: 50.0ms
 Ref Lvl: 8.3 DBM

Comments
 Basic Rate Mode
 2441-2482 MHz
 40 Channels

Cursor 1 2446.2617 -2.03

0.0000 0.00

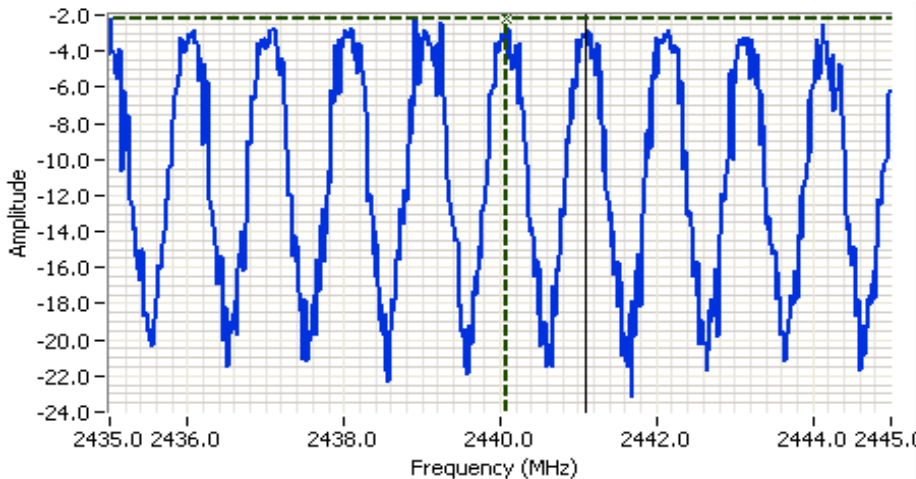

Analyzer Settings
 HP8564E,EMICF: 2440.000 MHz
 SPAN: 10.000 MHz
 RB: 100 kHz
 VB: 300 kHz
 Detector: POS
 Attn: 20 DB
 RL Offset: 0.0 DB
 Sweep Time: 50.0ms
 Ref Lvl: 8.3 DBM

Comments
 Channel Spacing
 1 MHz

Cursor 1 2440.0781 -2.20

Cursor 1 2441.0937 0.00

Delta Freq. 1.016

Delta Amplitude 2.20



Client:	Intel Corporation	Job Number:	J80397
Model:	Intel® Centrino® Wireless-N 1030 and Intel® Centrino® Wireless-N 130	T-Log Number:	T80458
Contact:	Steve Hackett	Account Manager:	Christine Krebill
Standard:	FCC.247, RSS-210 Issue 7	Class:	N/A

Run #4: Channel Occupancy and Number of Channels

Requirement: Frequency hopping systems in the **2400-2483.5 MHz** band shall use at least 15 channels.

The average time of occupancy on any channel shall not be greater than 0.4 seconds within a period of 0.4 seconds multiplied by the number of hopping channels employed. (Frequency hopping systems may avoid or suppress transmissions on a particular hopping frequency provided that a minimum of 15 channels are used.)

The device complies with the Bluetooth protocol and employs a minimum of 20 of the available 79 hopping channels when employing adaptive frequency hopping and all 79 channels when not. Channels are selected in a pseudo random manner to ensure, on average, all channels are used equally.

The hopping rate is 1600 hops per second although any one channel may be used for a single hop slot, 3 hop slots or 5 hop slots. The dwell time per channel is, therefore either 0.625ms (single slot), 1.875ms (three slot) or 3.125ms (five slot). The average time of occupancy will not exceed 0.4s in any time interval of 0.4s multiplied by the number of channels being used.

The plots below show the duration of the DH1, DH3 and DH5 packets as 0.54ms, 1.74ms and 2.79ms which are slightly shorter than the dwell time per channel detailed above to allow for settling times at each frequency hop.

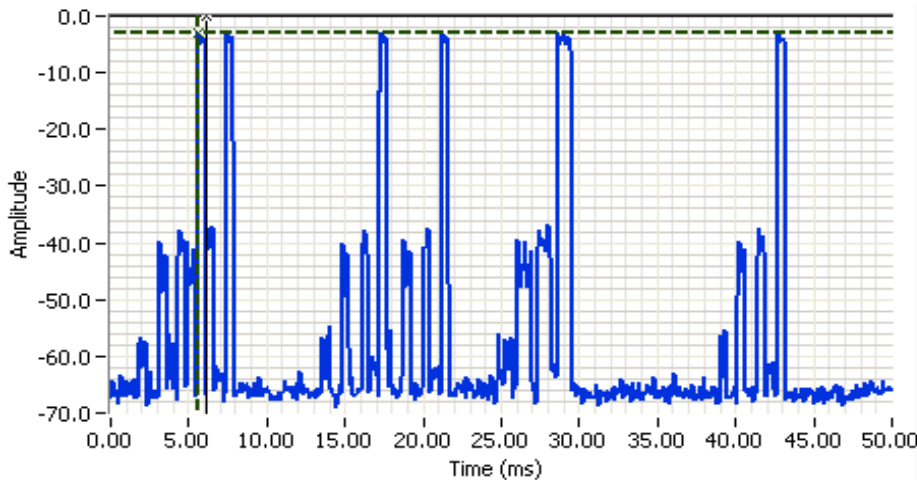

Analyzer Settings

HP8564E,EMICF: 2480.000 MHz
 SPAN: 0.000 MHz
 RB: 100 kHz
 VB: 300 kHz
 Detector: POS
 Attn: 20 DB
 RL Offset: 0.0 DB
 Sweep Time: 50.0ms
 Ref Lvl: 8.3 DBM

Comments

Basic Rate Mode
 DH1 Packets

Cursor 1	5.5833	-2.87	+	-	Delta Time (ms)	0.54
Cursor 1	6.1198	0.00	+	-	Delta Amplitude	2.87



Client:	Intel Corporation	Job Number:	J80397
Model:	Intel® Centrino® Wireless-N 1030 and Intel® Centrino® Wireless-N 130	T-Log Number:	T80458
Contact:	Steve Hackett	Account Manager:	Christine Krebill
Standard:	FCC.247, RSS-210 Issue 7	Class:	N/A

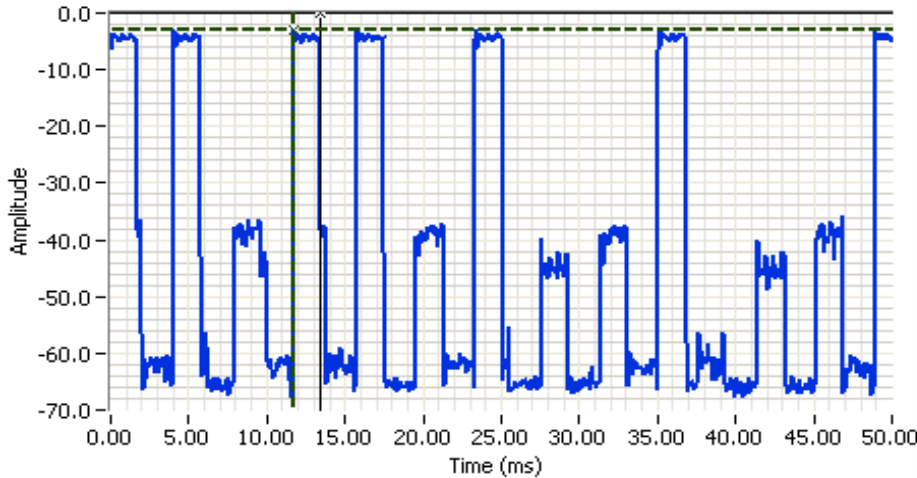

Analyzer Settings
 HP8564E,EMICF: 2480.000 MHz
 SPAN: 0.000 MHz
 RB: 100 kHz
 VB: 300 kHz
 Detector: POS
 Attn: 20 DB
 RL Offset: 0.0 DB
 Sweep Time: 50.0ms
 Ref Lvl: 8.3 DBM

Comments
 Basic Rate Mode
 DH3 Packets

Cursor 1 11.6667 -2.87  Delta Time (ms) 1.74
 Cursor 1 13.4115 0.00  Delta Amplitude 2.87

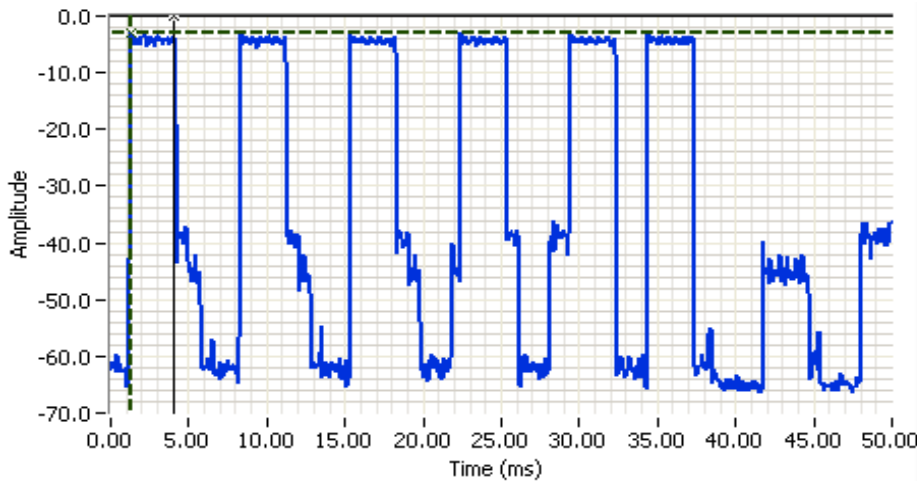

Analyzer Settings
 HP8564E,EMICF: 2480.000 MHz
 SPAN: 0.000 MHz
 RB: 100 kHz
 VB: 300 kHz
 Detector: POS
 Attn: 20 DB
 RL Offset: 0.0 DB
 Sweep Time: 50.0ms
 Ref Lvl: 8.3 DBM

Comments
 Basic Rate Mode
 DH5 packets

Cursor 1 1.2500 -2.87  Delta Time (ms) 2.79
 Cursor 1 4.0365 0.00  Delta Amplitude 2.87



Client:	Intel Corporation	Job Number:	J80397
Model:	Intel® Centrino® Wireless-N 1030 and Intel® Centrino® Wireless-N 130	T-Log Number:	T80458
		Account Manager:	Christine Krebill
Contact:	Steve Hackett		
Standard:	FCC.247, RSS-210 Issue 7	Class:	N/A

RSS 210 and FCC 15.247 (DSS) Radiated Spurious Emissions 802.11bg and Bluetooth - Transmitter Mode

Test Specific Details

Objective: The objective of this test session is to perform engineering evaluation testing of the EUT with respect to the specification listed above.

General Test Configuration

The EUT was installed into a test fixture such that the EUT was exposed (i.e. outside of a host PC).
For conducted emissions testing the measurement antenna port.

Summary of Results

For Bluetooth: Tx is chain B, Rx is chain B. For WiFi, only Chain A is used for transmit.

MAC Address: 00150079C6BF DRTU Tool Version 1.2.2-0177 Driver version 14.0.0.39

Run #	Mode	Channel	Measured Power	Test Performed	Limit	Result / Margin
1	BT 1Mb/s 802.11b	2402MHz	6.4	Radiated emissions 1- 10 GHz	FCC 15.247	48.8dBµV/m @ 2282.0MHz (-5.2dB)
		2412MHz	16.8			
2	BT 1Mb/s 802.11b	2480MHz	6.9			
		2462MHz	16.8			
3	BT 1Mb/s 802.11g	2402MHz	6.4			
		2412MHz	16.7			
4	BT 1Mb/s 802.11g	2480MHz	6.9			
		2462MHz	16.8			
WiFi mode for the following runs based on worst case mode from runs 1 through 4						
5	BT 1Mb/s 802.11b	2402MHz	6.4	Radiated emissions 1- 10 GHz	FCC 15.247	49.0dBµV/m @ 2368.9MHz (-5.0dB)
		2437MHz	16.7			
6	BT 1Mb/s 802.11b	2440MHz	7.0			
		2412MHz	16.8			
7	BT 1Mb/s 802.11b	2440MHz	7.0			
		2462MHz	16.8			
8	BT 1Mb/s 802.11b	2480MHz	6.9			
		2437MHz	16.7			
WiFi mode and channel and Bluetooth channel based on the worst case mode from runs 1 through 8						
9	BT 3Mb/s 802.11b	2440MHz	1.5	Radiated emissions 1- 10 GHz	FCC 15.247	46.1dBµV/m @ 2320.0MHz (-7.9dB)
		2462MHz	16.8			

Modifications Made During Testing

No modifications were made to the EUT during testing

Client:	Intel Corporation	Job Number:	J80397
Model:	Intel® Centrino® Wireless-N 1030 and Intel® Centrino® Wireless-N 130	T-Log Number:	T80458
		Account Manager:	Christine Krebill
Contact:	Steve Hackett		
Standard:	FCC.247, RSS-210 Issue 7	Class:	N/A

Deviations From The Standard

No deviations were made from the requirements of the standard.

Average Correction Factor Calculation - Bluetooth

Bluetooth uses a frequency hopping algorithm that means that the device, during normal operation, is only on a specific channel for a short period of time. The average correction factor is calculated as follows:

A maximum length packet has a duration of 5 time slots.

The hopping rate is 1600 hops/second so the maximum dwell time is 5/1600 seconds, or 3.125ms.

With a minimum of 20 hopping channels a channel will not be used more than 4 times in any 100ms period.

The maximum dwell time in a 100m period is $4 \times 3.125\text{ms} = 12.5\text{ms}$.

The average correction factor is, therefore, $20\log(12.5/100) = -18\text{dB}$

As this is a hopping radio the correction factor can be applied to the average value of the signal provided the average value was measured with the device continuously transmitting. DA 00-0705 permits the use of the average correction on the **measured average** value for frequency hopping radios.

As the measured average value was below the average limit the correction factor was not used for measurements in this data sheet.

Device Information:	WFM:	00150079C6BF
	DRTU Version:	1.2.2-0177
	Driver Version:	14.0.0.39
	Board Voltage:	3.31VDC

Client:	Intel Corporation	Job Number:	J80397
Model:	Intel® Centrino® Wireless-N 1030 and Intel® Centrino® Wireless-N 130	T-Log Number:	T80458
		Account Manager:	Christine Krebill
Contact:	Steve Hackett		
Standard:	FCC.247, RSS-210 Issue 7	Class:	N/A

Run # 1, Bluetooth/802.11bgn simultaneously: 1-10GHz, 802.11b @ 2412MHz Chain A, BT Basic Rate @ 2402MHz Chain B

	Target (dBm)	Power Settings	
		Measured (dBm)	Software Setting
Chain A	16.5	20.0	16.8
Chain B	7.0	8.0	6.4

Spurious Radiated Emissions, 1 - 10GHz excluding the allocated band:

Preamplifier and notch filter used for these scans

Preliminary Measurements (Peak versus average limit)

Frequency	Level	Pol	15.209/15.247		Detector	Azimuth	Height	Comments
MHz	dB μ V/m	V/H	Limit	Margin	Pk/QP/Avg	degrees	meters	
4822.500	44.7	V	54.0	-9.3	Peak	150	2.2	

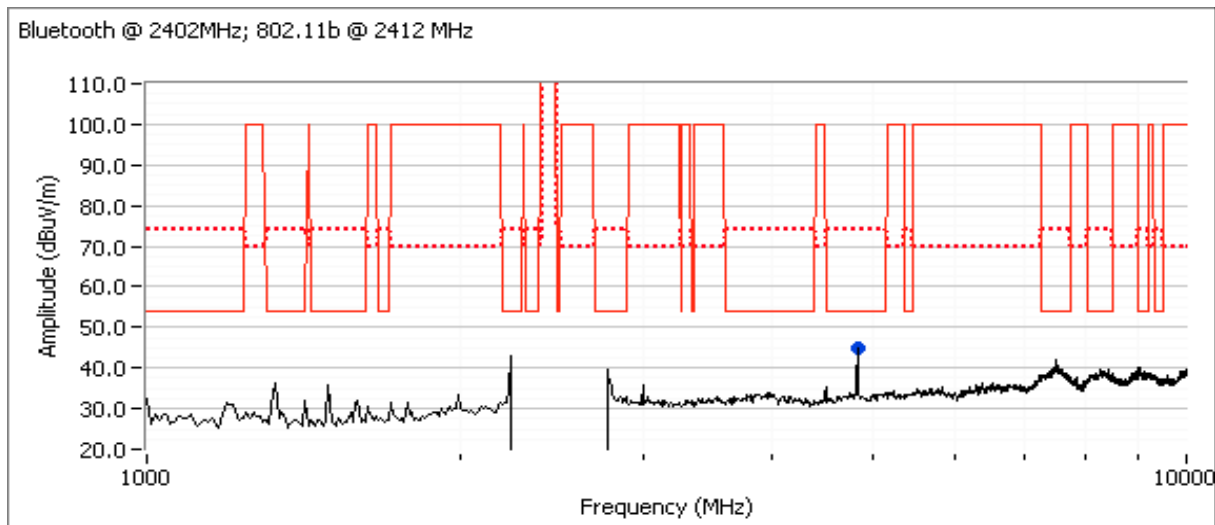

Client:	Intel Corporation	Job Number:	J80397
Model:	Intel® Centrino® Wireless-N 1030 and Intel® Centrino® Wireless-N 130	T-Log Number:	T80458
		Account Manager:	Christine Krebill
Contact:	Steve Hackett		
Standard:	FCC.247, RSS-210 Issue 7	Class:	N/A

Spurious Radiated Emissions, 2 - 3GHz

Preliminary Scan at ~ 20cm from the product to identify potential signals (No preamplifier used for these scans)

Preliminary measurements at ~ 20cm, RB=1MHz, VB=100kHz

Frequency MHz	Level dBµV/m	Pol V/H	15.209/15.247		Detector Pk/QP/Avg	Azimuth degrees	Height meters	Comments
			Limit	Margin				
2243.330	43.2	H	54.0	-10.8	Peak	204	1.0	
2281.670	43.6	H	54.0	-10.4	Peak	204	1.0	
2323.330	40.6	H	54.0	-13.4	Peak	204	1.0	
2523.330	49.8	H	70.0	-20.2	Peak	204	1.0	
2563.330	50.3	H	70.0	-19.7	Peak	204	1.0	

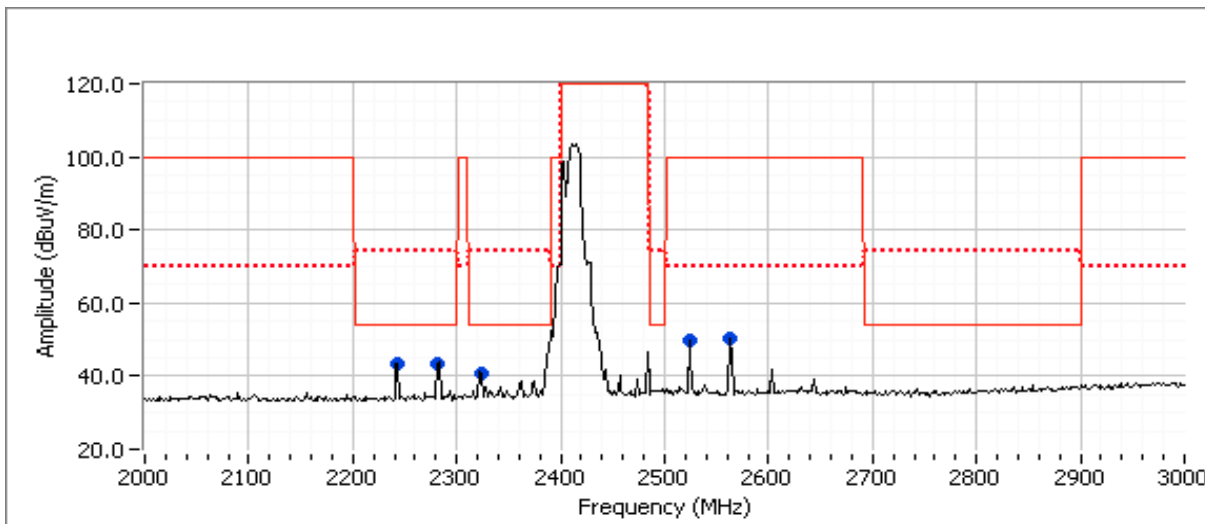

Final measurements at 3m

Frequency MHz	Level dBµV/m	Pol V/H	15.209/15.247		Detector Pk/QP/Avg	Azimuth degrees	Height meters	Comments
			Limit	Margin				
2281.990	48.8	H	54.0	-5.2	AVG	205	1.0	RB 1MHz;VB 10 Hz;Pk
2281.840	56.3	H	74.0	-17.7	PK	205	1.0	RB 1MHz;VB 3MHz;Pk
4824.000	45.5	V	54.0	-8.5	AVG	138	1.3	
4824.090	49.1	V	74.0	-24.9	PK	138	1.3	
2241.980	47.8	H	54.0	-6.2	AVG	202	1.0	RB 1MHz;VB 10 Hz;Pk
2241.930	56.7	H	74.0	-17.3	PK	202	1.0	RB 1MHz;VB 3MHz;Pk
2321.960	48.5	H	54.0	-5.5	AVG	206	1.0	RB 1MHz;VB 10 Hz;Pk
2321.810	56.4	H	74.0	-17.6	PK	206	1.0	RB 1MHz;VB 3MHz;Pk

Note 1: For emissions in restricted bands, the limit of 15.209 was used. For all other emissions, the limit is -30dBc for peak measurements in a measurement bandwidth of 100kHz.

Client:	Intel Corporation	Job Number:	J80397
Model:	Intel® Centrino® Wireless-N 1030 and Intel® Centrino® Wireless-N 130	T-Log Number:	T80458
		Account Manager:	Christine Krebill
Contact:	Steve Hackett		
Standard:	FCC.247, RSS-210 Issue 7	Class:	N/A

Run # 2, Bluetooth/802.11bgn simultaneously: 1-10GHz, 802.11b @ 2462MHz Chain A, BT Basic Rate @ 2480MHz Chain B

	Target (dBm)	Power Settings	
		Measured (dBm)	Software Setting
Chain A	16.5	20.0	16.8
Chain B	7.0	8.0	6.9

Spurious Radiated Emissions, 1 - 10GHz excluding the allocated band:

Preamplifier and notch filter used for these scans

Preliminary Measurements (Peak versus average limit)

Frequency	Level	Pol	15.209/15.247		Detector	Azimuth	Height	Comments
MHz	dB μ V/m	V/H	Limit	Margin	Pk/QP/Avg	degrees	meters	
4923.970	49.9	V	54.0	-4.1	Peak	233	1.6	802.11b 2nd harmonic

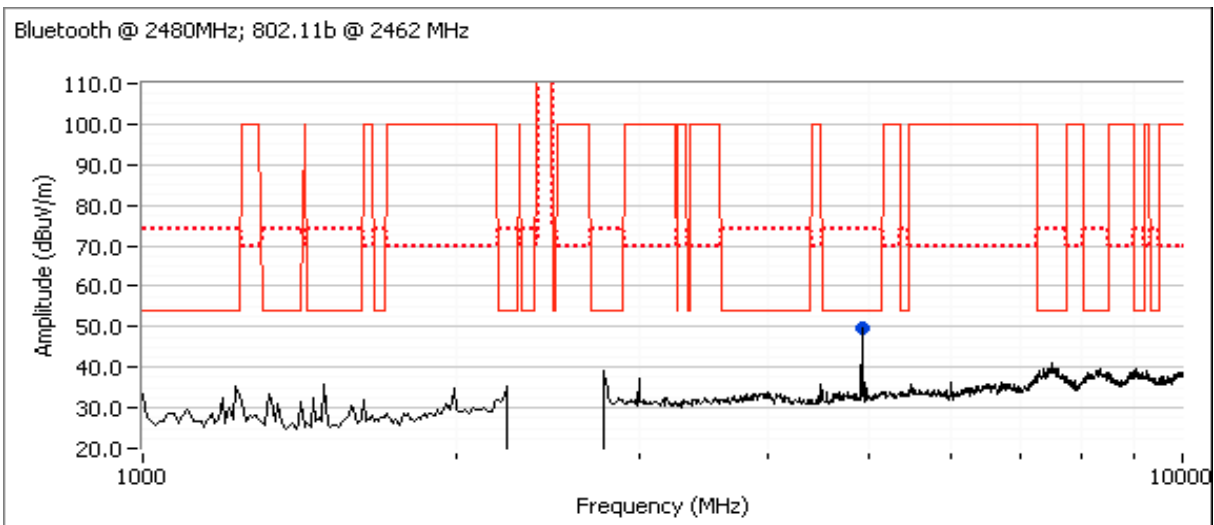

Client:	Intel Corporation	Job Number:	J80397
Model:	Intel® Centrino® Wireless-N 1030 and Intel® Centrino® Wireless-N 130	T-Log Number:	T80458
		Account Manager:	Christine Krebill
Contact:	Steve Hackett		
Standard:	FCC.247, RSS-210 Issue 7	Class:	N/A

Spurious Radiated Emissions, 2 - 3GHz

Preliminary Scan at ~ 20cm from the product to identify potential signals (No preamplifier used for these scans)

Preliminary measurements at ~ 20cm, RB=1MHz, VB=100kHz

Preliminary measurements at ~ 20cm, RB=1MHz, VB=100kHz

Frequency MHz	Level dBµV/m	Pol V/H	15.209/15.247		Detector Pk/QP/Avg	Azimuth degrees	Height meters	Comments
			Limit	Margin				
2320.000	46.0	H	54.0	-8.0	Peak	206	1.0	
2360.000	44.5	H	54.0	-9.5	Peak	206	1.0	
2601.670	44.8	H	70.0	-25.2	Peak	206	1.0	
2498.330	41.2	H	54.0	-12.8	Peak	206	1.0	
2641.670	43.2	H	70.0	-26.8	Peak	206	1.0	

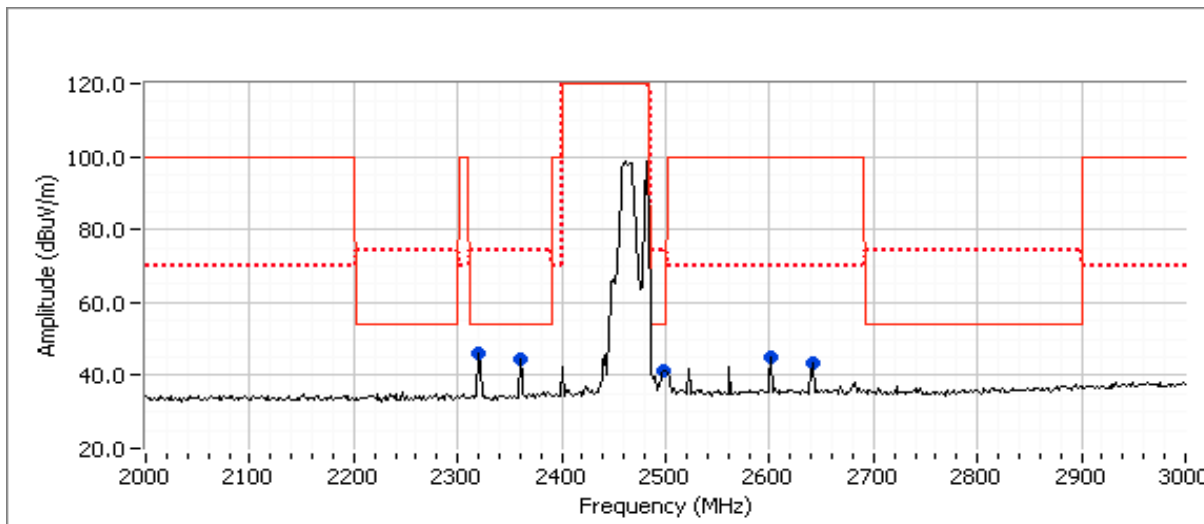

Final measurements at 3m

Frequency MHz	Level dBµV/m	Pol V/H	15.209/15.247		Detector Pk/QP/Avg	Azimuth degrees	Height meters	Comments
			Limit	Margin				
2496.210	51.0	H	54.0	-3.0	AVG	72	1.2	RB 1MHz;VB 10 Hz;Pk
2497.310	59.6	H	74.0	-14.4	PK	72	1.2	RB 1MHz;VB 3MHz;Pk
4923.990	50.9	V	54.0	-3.1	AVG	199	1.0	
4923.940	53.0	V	74.0	-21.0	PK	199	1.0	
2320.000	50.8	H	54.0	-3.2	AVG	208	1.0	RB 1MHz;VB 10 Hz;Pk
2319.950	57.6	H	74.0	-16.4	PK	208	1.0	RB 1MHz;VB 3MHz;Pk
2360.030	49.8	H	54.0	-4.2	AVG	71	1.3	RB 1MHz;VB 10 Hz;Pk
2360.130	57.2	H	74.0	-16.8	PK	71	1.3	RB 1MHz;VB 3MHz;Pk

Note 1: For emissions in restricted bands, the limit of 15.209 was used. For all other emissions, the limit is -30dBc for peak measurements in a measurement bandwidth of 100kHz.

Client:	Intel Corporation	Job Number:	J80397
Model:	Intel® Centrino® Wireless-N 1030 and Intel® Centrino® Wireless-N 130	T-Log Number:	T80458
		Account Manager:	Christine Krebill
Contact:	Steve Hackett		
Standard:	FCC.247, RSS-210 Issue 7	Class:	N/A

Run # 3, Bluetooth/802.11bgn simultaneously: 1-10GHz, 802.11g @ 2412MHz Chain A, BT Basic Rate @ 2402MHz Chain B

	Target (dBm)	Power Settings	
		Measured (dBm)	Software Setting
Chain A	16.5	25.0	16.7
Chain B	7.0	8.0	6.4

Spurious Radiated Emissions, 1 - 10GHz excluding the allocated band:

Preamplifier and notch filter used for these scans

Preliminary Measurements (Peak versus average limit)

Frequency	Level	Pol	15.209/15.247		Detector	Azimuth	Height	Comments
MHz	dB μ V/m	V/H	Limit	Margin	Pk/QP/Avg	degrees	meters	
4807.200	37.9	V	54.0	-16.1	Peak	126	1.9	

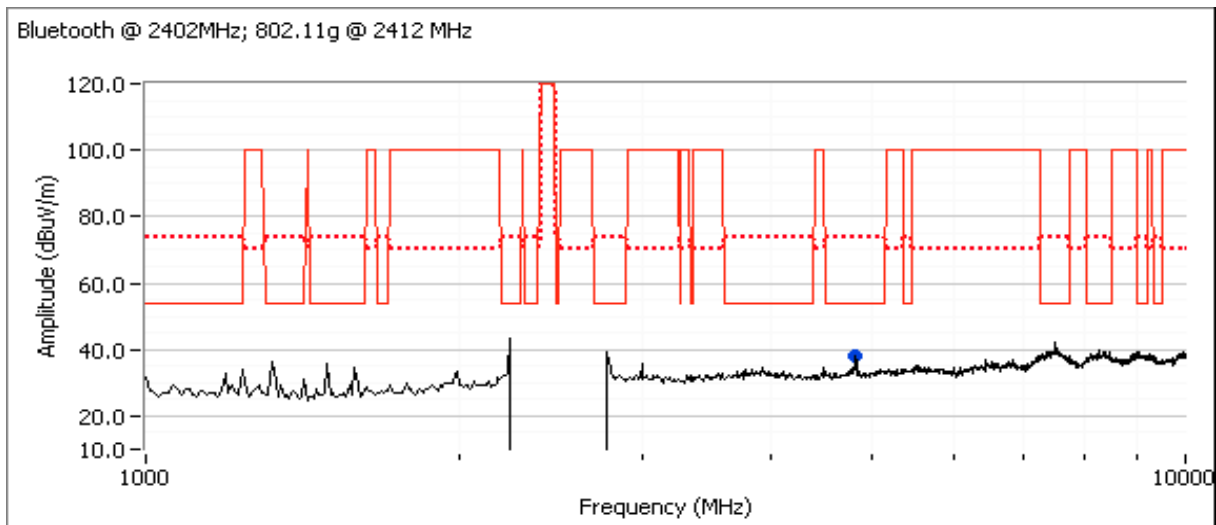

Client:	Intel Corporation	Job Number:	J80397
Model:	Intel® Centrino® Wireless-N 1030 and Intel® Centrino® Wireless-N 130	T-Log Number:	T80458
		Account Manager:	Christine Krebill
Contact:	Steve Hackett		
Standard:	FCC.247, RSS-210 Issue 7	Class:	N/A

Spurious Radiated Emissions, 2 - 3GHz

Preliminary Scan at ~ 20cm from the product to identify potential signals (No preamplifier used for these scans)

Preliminary measurements at ~ 20cm, RB=1MHz, VB=100kHz

Frequency MHz	Level dBµV/m	Pol V/H	15.209/15.247		Detector Pk/QP/Avg	Azimuth degrees	Height meters	Comments
			Limit	Margin				
2241.670	39.2	H	54.0	-14.8	Peak	207	1.0	
2281.670	40.0	H	54.0	-14.0	Peak	207	1.0	
2321.670	39.0	H	54.0	-15.0	Peak	207	1.0	
2523.330	44.8	H	70.0	-25.2	Peak	207	1.0	
2563.330	44.1	H	70.0	-25.9	Peak	207	1.0	

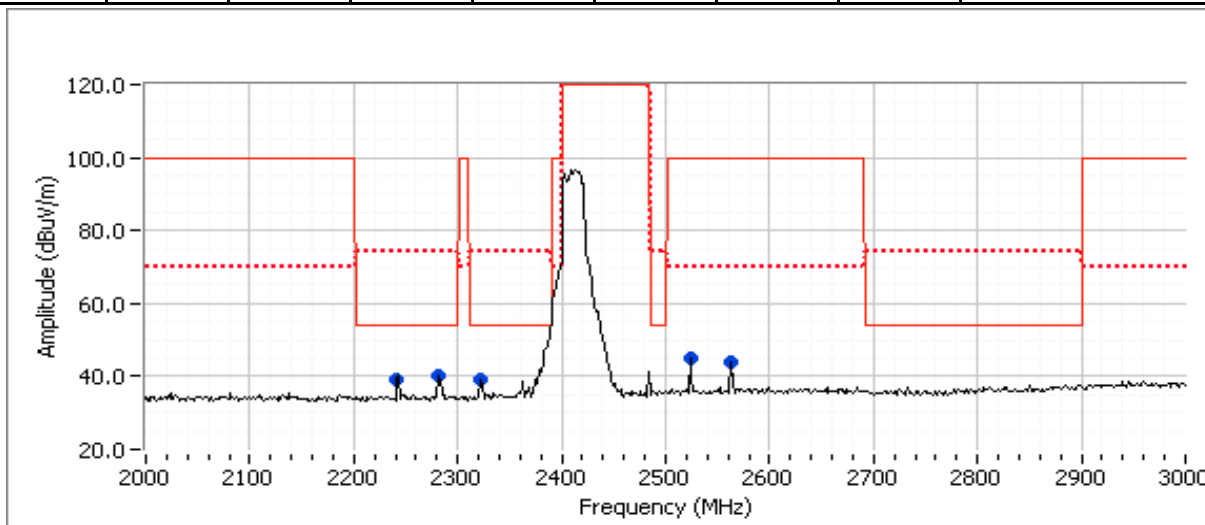

Final measurements at 3m

Frequency MHz	Level dBµV/m	Pol V/H	15.209/15.247		Detector Pk/QP/Avg	Azimuth degrees	Height meters	Comments
			Limit	Margin				
2282.040	50.1	H	54.0	-3.9	AVG	242	1.0	RB 1MHz;VB 10 Hz;Pk
2282.020	56.5	H	74.0	-17.5	PK	242	1.0	RB 1MHz;VB 3MHz;Pk
4803.930	37.4	V	54.0	-16.6	AVG	207	1.1	RB 1MHz;VB 10 Hz;Pk
4804.300	45.0	V	74.0	-29.0	PK	207	1.1	RB 1MHz;VB 3MHz;Pk
2241.970	47.5	H	54.0	-6.5	AVG	199	1.1	RB 1MHz;VB 10 Hz;Pk
2241.840	56.7	H	74.0	-17.3	PK	199	1.1	RB 1MHz;VB 3MHz;Pk
2241.960	45.8	V	54.0	-8.2	AVG	161	1.6	RB 1MHz;VB 10 Hz;Pk
2241.640	55.4	V	74.0	-18.6	PK	161	1.6	RB 1MHz;VB 3MHz;Pk
2321.970	48.2	H	54.0	-5.8	AVG	205	1.0	RB 1MHz;VB 10 Hz;Pk
2322.140	56.5	H	74.0	-17.5	PK	205	1.0	RB 1MHz;VB 3MHz;Pk

Note 1: For emissions in restricted bands, the limit of 15.209 was used. For all other emissions, the limit is -30dBc for peak measurements in a measurement bandwidth of 100kHz.

Client:	Intel Corporation	Job Number:	J80397
Model:	Intel® Centrino® Wireless-N 1030 and Intel® Centrino® Wireless-N 130	T-Log Number:	T80458
		Account Manager:	Christine Krebill
Contact:	Steve Hackett		
Standard:	FCC.247, RSS-210 Issue 7	Class:	N/A

Run # 4, Bluetooth/802.11bgn simultaneously: 1-10GHz, 802.11g @ 2462MHz Chain A, BT Basic Rate @ 2480MHz Chain B

	Target (dBm)	Power Settings	
		Measured (dBm)	Software Setting
Chain A	16.5	25.0	16.8
Chain B	7.0	8.0	6.9

Spurious Radiated Emissions, 1 - 10GHz excluding the allocated band:

Preamplifier and notch filter used for these scans

Preliminary Measurements (Peak versus average limit)

Frequency	Level	Pol	15.209/15.247		Detector	Azimuth	Height	Comments
MHz	dBµV/m	V/H	Limit	Margin	Pk/QP/Avg	degrees	meters	
4922.870	41.9	V	54.0	-12.1	Peak	157	1.9	

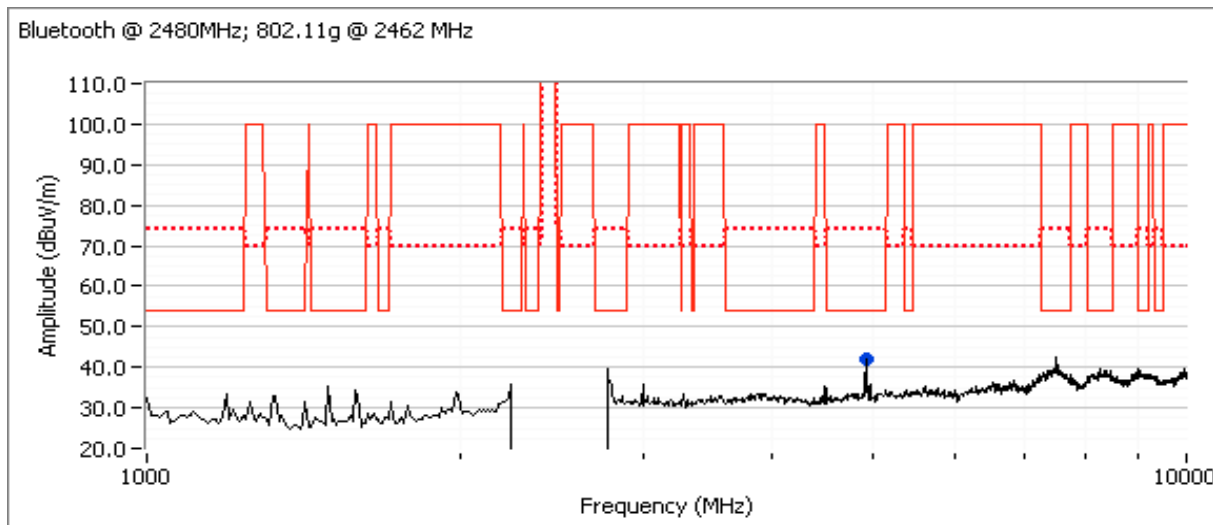

Client:	Intel Corporation	Job Number:	J80397
Model:	Intel® Centrino® Wireless-N 1030 and Intel® Centrino® Wireless-N 130	T-Log Number:	T80458
		Account Manager:	Christine Krebill
Contact:	Steve Hackett		
Standard:	FCC.247, RSS-210 Issue 7	Class:	N/A

Spurious Radiated Emissions, 2 - 3GHz

Preliminary Scan at ~ 20cm from the product to identify potential signals (No preamplifier used for these scans)

Preliminary measurements at ~ 20cm, RB=1MHz, VB=100kHz

Frequency MHz	Level dBµV/m	Pol V/H	15.209/15.247		Detector Pk/QP/Avg	Azimuth degrees	Height meters	Comments
			Limit	Margin				
2320.000	42.8	H	54.0	-11.2	Peak	205	1.0	
2360.000	43.3	H	54.0	-10.7	Peak	205	1.0	
2641.670	43.2	H	70.0	-26.8	Peak	205	1.0	

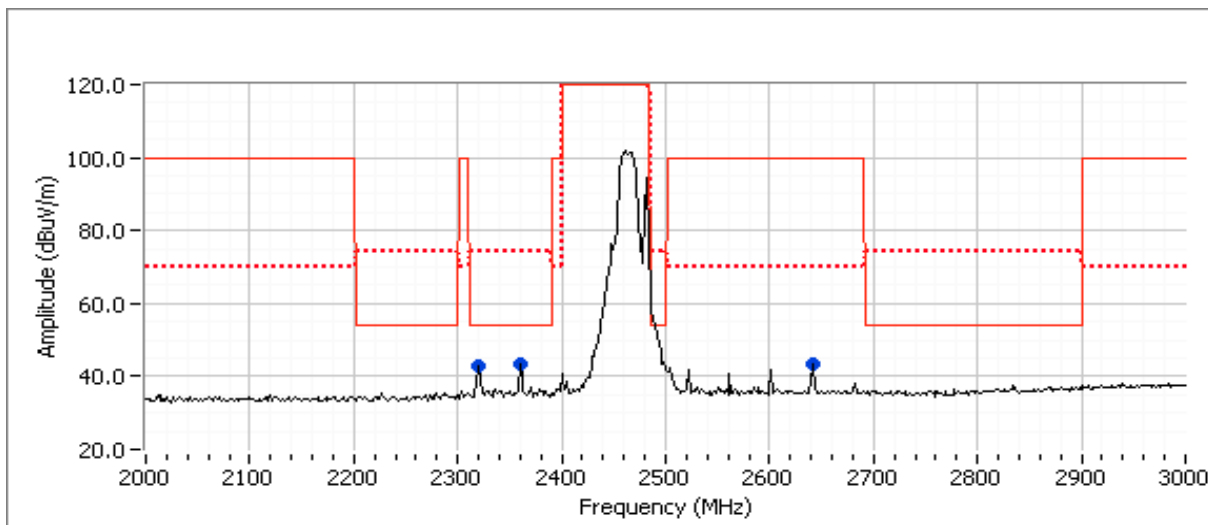

Final measurements at 3m

Frequency MHz	Level dBµV/m	Pol V/H	15.209/15.247		Detector Pk/QP/Avg	Azimuth degrees	Height meters	Comments Setting
			Limit	Margin				
2359.970	50.7	H	54.0	-3.3	AVG	75	1.2	RB 1MHz;VB 10 Hz;Pk
2359.700	57.6	H	74.0	-16.4	PK	75	1.2	RB 1MHz;VB 3MHz;Pk
4924.270	40.2	V	54.0	-13.8	AVG	165	1.0	RB 1MHz;VB 10 Hz;Pk
4919.420	52.7	V	74.0	-21.3	PK	165	1.0	RB 1MHz;VB 3MHz;Pk
2320.000	50.5	H	54.0	-3.5	AVG	204	1.0	RB 1MHz;VB 10 Hz;Pk
2319.950	57.7	H	74.0	-16.3	PK	204	1.0	RB 1MHz;VB 3MHz;Pk

Note 2: For emissions in restricted bands, the limit of 15.209 was used. For all other emissions, the limit is -30dBc for peak measurements in a measurement bandwidth of 100kHz.

Client:	Intel Corporation	Job Number:	J80397
Model:	Intel® Centrino® Wireless-N 1030 and Intel® Centrino® Wireless-N 130	T-Log Number:	T80458
		Account Manager:	Christine Krebill
Contact:	Steve Hackett		
Standard:	FCC.247, RSS-210 Issue 7	Class:	N/A

Run # 5, Bluetooth/802.11bgn simultaneously: 1-10GHz, 802.11b @ 2437MHz Chain A, BT Basic Rate @ 2402MHz Chain B

	Power Settings		
	Target (dBm)	Measured (dBm)	Software Setting
Chain A	16.5	16.7	20.0
Chain B	7.0	6.4	8.0

Spurious Radiated Emissions, 1 - 10GHz excluding the allocated band:

Preamplifier and notch filter used for these scans

Preliminary Measurements (Peak versus average limit)

Frequency	Level	Pol	15.209/15.247		Detector	Azimuth	Height	Comments
MHz	dB μ V/m	v/h	Limit	Margin	Pk/QP/Avg	degrees	meters	
4873.910	48.9	V	54.0	-5.1	Peak	201	1.3	

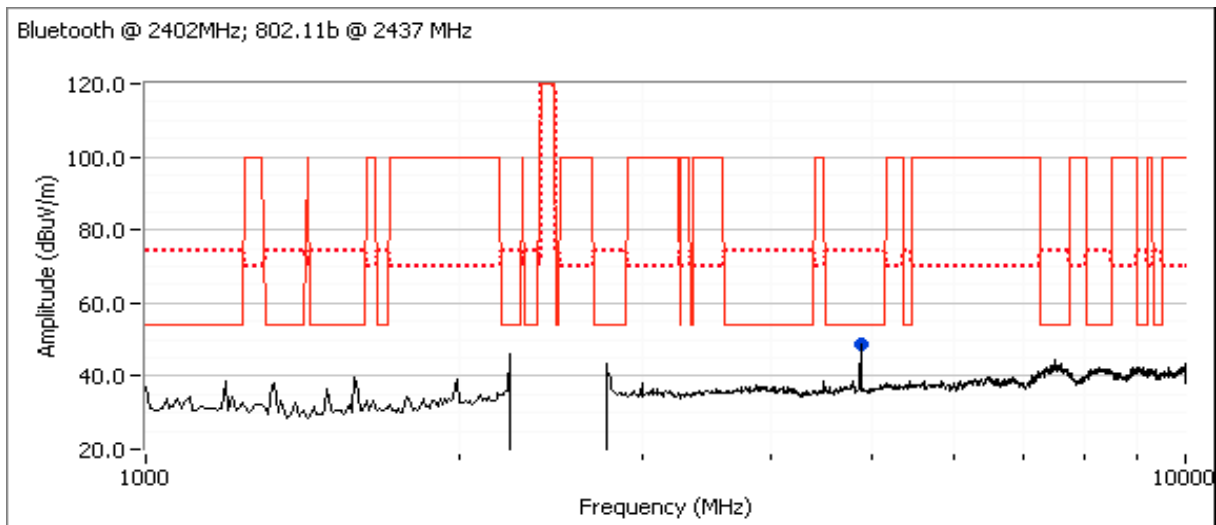

Client:	Intel Corporation	Job Number:	J80397
Model:	Intel® Centrino® Wireless-N 1030 and Intel® Centrino® Wireless-N 130	T-Log Number:	T80458
		Account Manager:	Christine Krebill
Contact:	Steve Hackett		
Standard:	FCC.247, RSS-210 Issue 7	Class:	N/A

Spurious Radiated Emissions, 2 - 3GHz

Preliminary Scan at ~ 20cm from the product to identify potential signals (No preamplifier used for these scans)

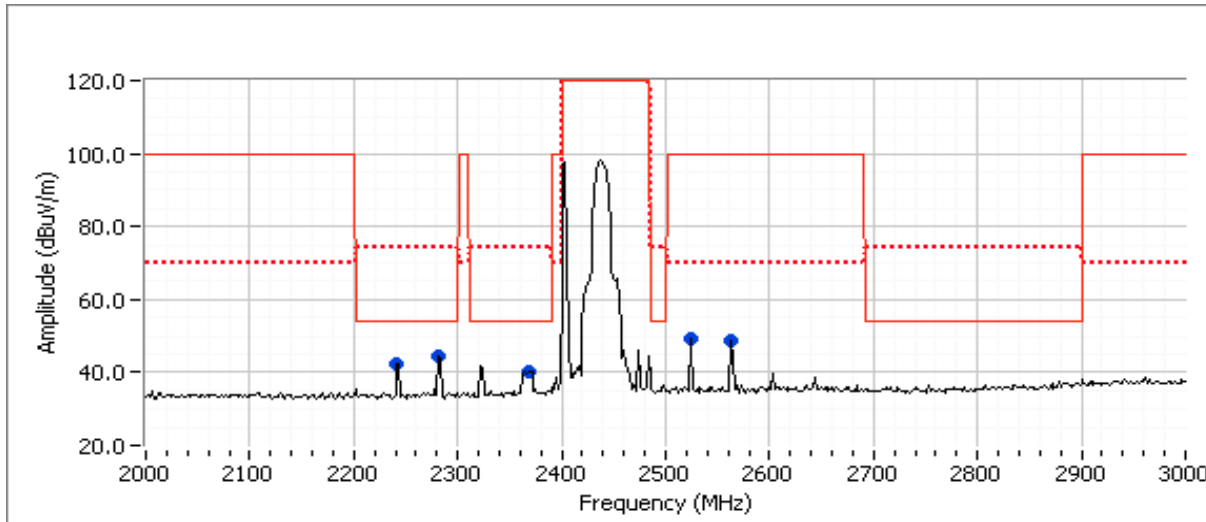

Preliminary measurements at ~ 20cm, RB=1MHz, VB=100kHz

Frequency	Level	Pol	15.209/15.247		Detector	Azimuth	Height	Comments
MHz	dBuV/m	v/h	Limit	Margin	Pk/QP/Avg	degrees	meters	
2241.670	42.2	H	54.0	-11.8	Peak	206	1.0	
2281.670	44.3	H	54.0	-9.7	Peak	206	1.0	
2368.330	40.4	H	54.0	-13.6	Peak	206	1.0	
2523.330	49.5	H	70.0	-20.5	Peak	206	1.0	
2563.330	48.8	H	70.0	-21.2	Peak	206	1.0	

Final measurements at 3m

Frequency	Level	Pol	15.209/15.247		Detector	Azimuth	Height	Comments
MHz	dBuV/m	v/h	Limit	Margin	Pk/QP/Avg	degrees	meters	Setting
2368.860	49.0	H	54.0	-5.0	AVG	85	1.0	RB 1MHz;VB 10 Hz;Pk
2368.300	57.6	H	74.0	-16.4	PK	85	1.0	RB 1MHz;VB 3MHz;Pk
2241.940	48.2	H	54.0	-5.8	AVG	75	1.1	RB 1MHz;VB 10 Hz;Pk
2241.770	56.3	H	74.0	-17.7	PK	75	1.1	RB 1MHz;VB 3MHz;Pk
2281.940	48.0	H	54.0	-6.0	AVG	207	1.0	RB 1MHz;VB 10 Hz;Pk
2282.000	56.0	H	74.0	-18.0	PK	207	1.0	RB 1MHz;VB 3MHz;Pk
4873.970	47.6	V	54.0	-6.4	AVG	225	1.7	RB 1MHz;VB 10 Hz;Pk
4874.070	50.4	V	74.0	-23.6	PK	225	1.7	RB 1MHz;VB 3MHz;Pk

Note 2: For emissions in restricted bands, the limit of 15.209 was used. For all other emissions, the limit is -30dBc for peak measurements in a measurement bandwidth of 100kHz.

Client:	Intel Corporation	Job Number:	J80397
Model:	Intel® Centrino® Wireless-N 1030 and Intel® Centrino® Wireless-N 130	T-Log Number:	T80458
		Account Manager:	Christine Krebill
Contact:	Steve Hackett		
Standard:	FCC.247, RSS-210 Issue 7	Class:	N/A

Run # 6, Bluetooth/802.11bgn simultaneously: 1-10GHz, 802.11b @ 2412MHz Chain A, BT Basic Rate @ 2440MHz Chain B

	Target (dBm)	Power Settings Measured (dBm)	Software Setting
Chain A	16.5	16.8	20.0
Chain B	7.0	7.0	8.0

**Spurious Radiated Emissions, 1 - 10GHz excluding the allocated band:
Preamplifier and notch filter used for these scans**

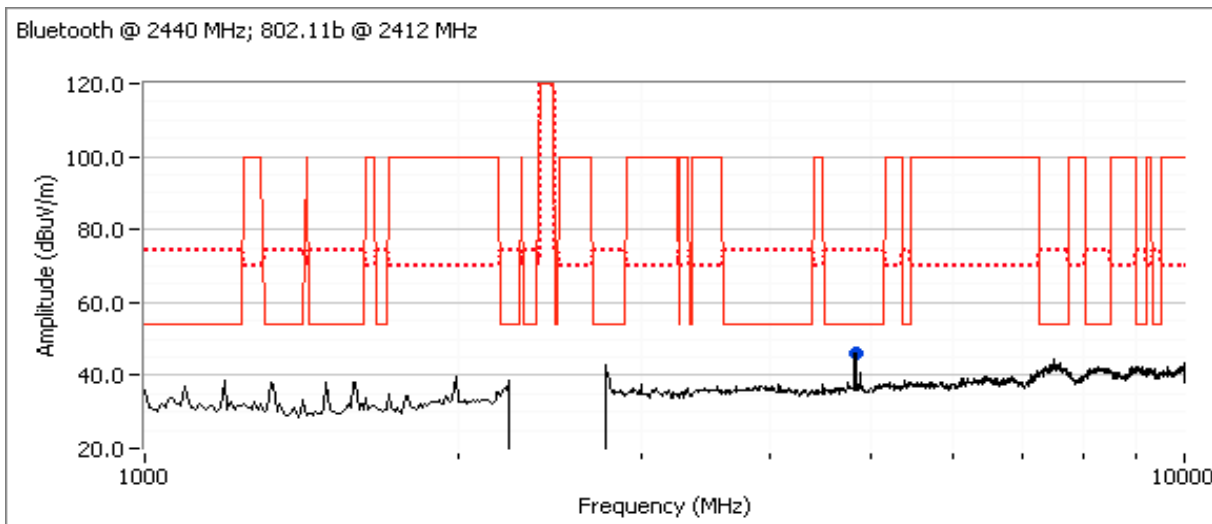

Preliminary Measurements (Peak versus average limit)

Frequency	Level	Pol	15.209/15.247		Detector	Azimuth	Height	Comments
MHz	dBuV/m	v/h	Limit	Margin	Pk/QP/Avg	degrees	meters	
4824.060	45.9	V	54.0	-8.1	Peak	138	1.3	

Client:	Intel Corporation	Job Number:	J80397
Model:	Intel® Centrino® Wireless-N 1030 and Intel® Centrino® Wireless-N 130	T-Log Number:	T80458
		Account Manager:	Christine Krebill
Contact:	Steve Hackett		
Standard:	FCC.247, RSS-210 Issue 7	Class:	N/A

Spurious Radiated Emissions, 2 - 3GHz

Preliminary Scan at ~ 20cm from the product to identify potential signals (No preamplifier used for these scans)

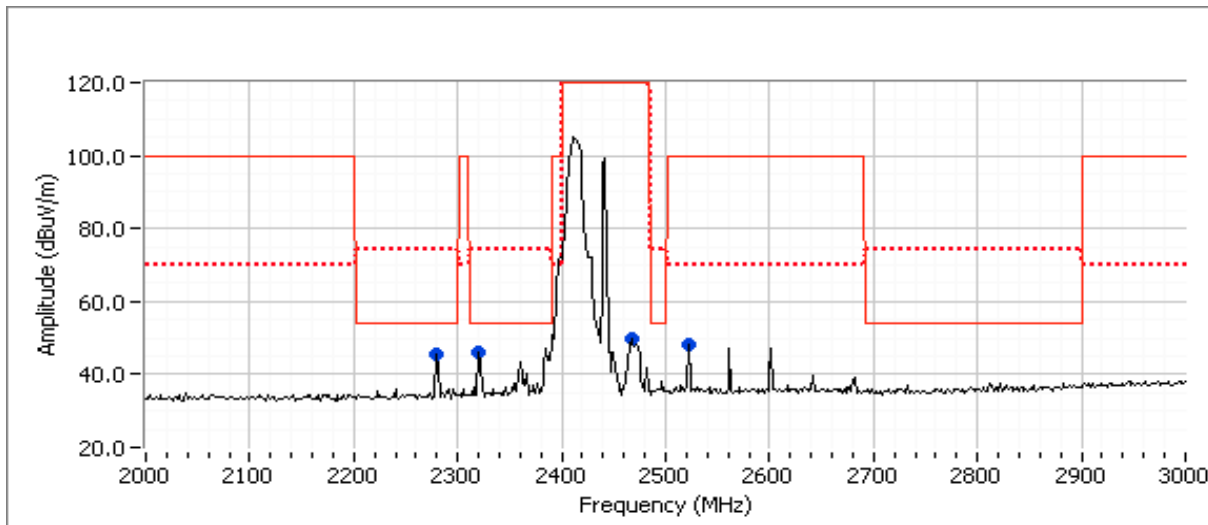

Preliminary measurements at ~ 20cm, RB=1MHz, VB=100kHz

Frequency	Level	Pol	15.209/15.247		Detector	Azimuth	Height	Comments
MHz	dBuV/m	v/h	Limit	Margin	Pk/QP/Avg	degrees	meters	
2280.000	45.5	H	54.0	-8.5	Peak	206	1.0	6
2320.000	46.1	H	54.0	-7.9	Peak	206	1.0	6
2466.670	49.6	H	120.0	-70.4	Peak	206	1.0	6
2521.670	48.2	H	70.0	-21.8	Peak	206	1.0	6

Final measurements at 3m

Frequency	Level	Pol	15.209/15.247		Detector	Azimuth	Height	Comments
MHz	dBuV/m	v/h	Limit	Margin	Pk/QP/Avg	degrees	meters	Setting
2320.030	50.0	H	54.0	-4.0	AVG	207	1.0	RB 1MHz;VB 10 Hz;Pk
2319.650	57.7	H	74.0	-16.3	PK	207	1.0	RB 1MHz;VB 3MHz;Pk
2280.050	48.7	H	54.0	-5.3	AVG	93	1.3	RB 1MHz;VB 10 Hz;Pk
2279.550	56.7	H	74.0	-17.3	PK	93	1.3	RB 1MHz;VB 3MHz;Pk
4823.980	45.8	V	54.0	-8.2	AVG	133	1.1	RB 1MHz;VB 10 Hz;Pk
4823.900	49.1	V	74.0	-24.9	PK	133	1.1	RB 1MHz;VB 3MHz;Pk

Note 2: For emissions in restricted bands, the limit of 15.209 was used. For all other emissions, the limit is -30dBc for peak measurements in a measurement bandwidth of 100kHz.

Client:	Intel Corporation	Job Number:	J80397
Model:	Intel® Centrino® Wireless-N 1030 and Intel® Centrino® Wireless-N 130	T-Log Number:	T80458
		Account Manager:	Christine Krebill
Contact:	Steve Hackett		
Standard:	FCC.247, RSS-210 Issue 7	Class:	N/A

Run # 7, Bluetooth/802.11bgn simultaneously: 1-10GHz, 802.11b @ 2462MHz Chain A, BT Basic Rate @ 2440MHz Chain B

	Target (dBm)	Power Settings Measured (dBm)	Software Setting
Chain A	16.5	16.8	20.0
Chain B	7.0	7.0	8.0

Spurious Radiated Emissions, 1 - 10GHz excluding the allocated band:
 Preamplifier and notch filter used for these scans

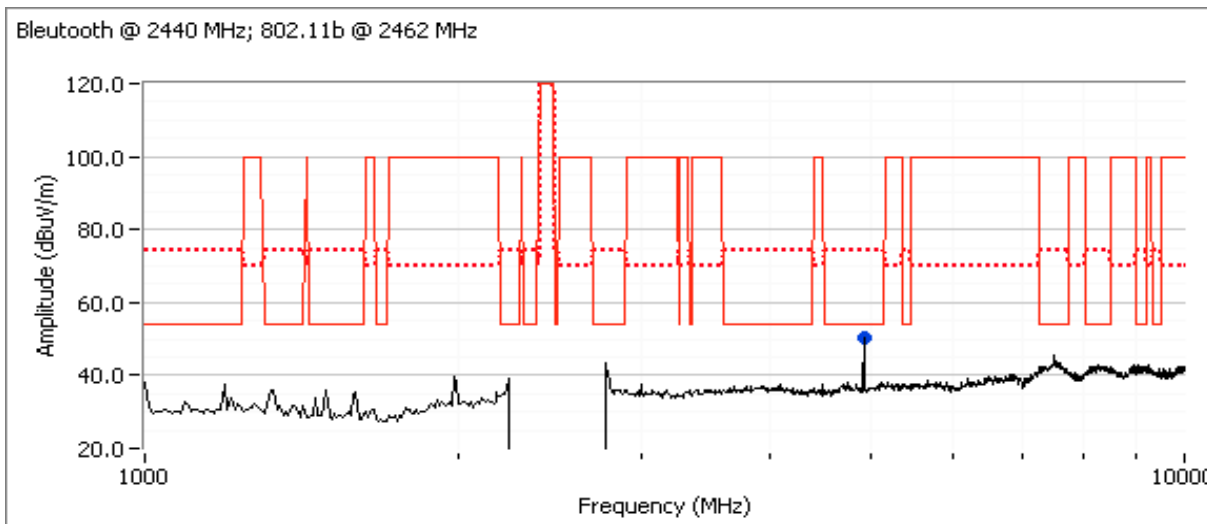

Preliminary Measurements (Peak versus average limit)

Frequency	Level	Pol	15.209/15.247		Detector	Azimuth	Height	Comments
MHz	dBuV/m	v/h	Limit	Margin	Pk/QP/Avg	degrees	meters	
4923.810	50.3	V	54.0	-3.7	Peak	108	1.6	

Note 1: This is the second harmonic of the 802.11b signal and not an intermodulation product. Measurement of harmonics directly related to the 802.11 transmitter are provided in the 802.11 radiated spurious emissions test data.

Client:	Intel Corporation	Job Number:	J80397
Model:	Intel® Centrino® Wireless-N 1030 and Intel® Centrino® Wireless-N 130	T-Log Number:	T80458
		Account Manager:	Christine Krebill
Contact:	Steve Hackett		
Standard:	FCC.247, RSS-210 Issue 7	Class:	N/A

Spurious Radiated Emissions, 2 - 3GHz

Preliminary Scan at ~ 20cm from the product to identify potential signals (No preamplifier used for these scans)

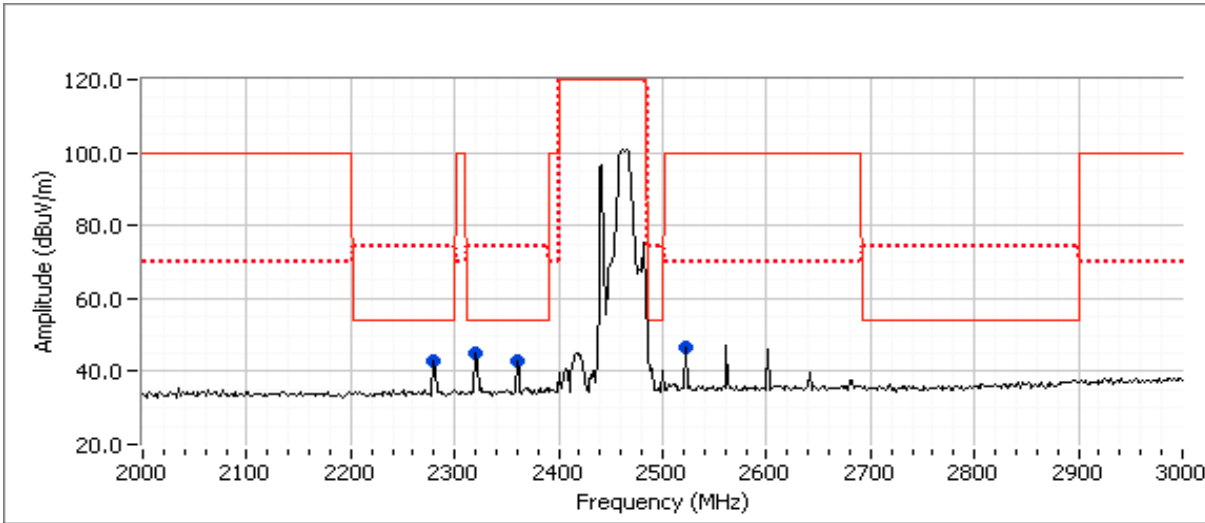

Preliminary measurements at ~ 20cm, RB=1MHz, VB=100kHz

Frequency	Level	Pol	15.209/15.247		Detector	Azimuth	Height	Comments
MHz	dBµV/m	v/h	Limit	Margin	Pk/QP/Avg	degrees	meters	
2280.000	42.8	H	54.0	-11.2	Peak	200	1.0	
2320.000	45.0	H	54.0	-9.0	Peak	200	1.0	
2360.000	43.0	H	54.0	-11.0	Peak	200	1.0	
2521.670	46.7	H	70.0	-23.3	Peak	200	1.0	

Final measurements at 3m

Frequency	Level	Pol	15.209/15.247		Detector	Azimuth	Height	Comments
MHz	dBµV/m	v/h	Limit	Margin	Pk/QP/Avg	degrees	meters	Setting
2320.000	49.8	H	54.0	-4.2	AVG	26	1.0	RB 1MHz;VB 10 Hz;Pk
2359.980	48.4	H	54.0	-5.6	AVG	62	1.0	RB 1MHz;VB 10 Hz;Pk
2279.970	48.1	H	54.0	-5.9	AVG	23	1.0	RB 1MHz;VB 10 Hz;Pk
2279.590	58.1	H	74.0	-15.9	PK	23	1.0	RB 1MHz;VB 3MHz;Pk
2320.080	56.9	H	74.0	-17.1	PK	26	1.0	RB 1MHz;VB 3MHz;Pk
2359.920	56.9	H	74.0	-17.1	PK	62	1.0	RB 1MHz;VB 3MHz;Pk

Note 2: For emissions in restricted bands, the limit of 15.209 was used. For all other emissions, the limit is -30dBc for peak measurements in a measurement bandwidth of 100kHz.

Client:	Intel Corporation	Job Number:	J80397
Model:	Intel® Centrino® Wireless-N 1030 and Intel® Centrino® Wireless-N 130	T-Log Number:	T80458
		Account Manager:	Christine Krebill
Contact:	Steve Hackett		
Standard:	FCC.247, RSS-210 Issue 7	Class:	N/A

Run # 8, Bluetooth/802.11bgn simultaneously: 1-10GHz, 802.11b @ 2437MHz Chain A, BT Basic Rate @ 2480MHz Chain B

	Target (dBm)	Power Settings Measured (dBm)	Software Setting
Chain A	16.5	16.7	20.0
Chain B	7.0	6.9	8.0

**Spurious Radiated Emissions, 1 - 10GHz excluding the allocated band:
Preamplifier and notch filter used for these scans**

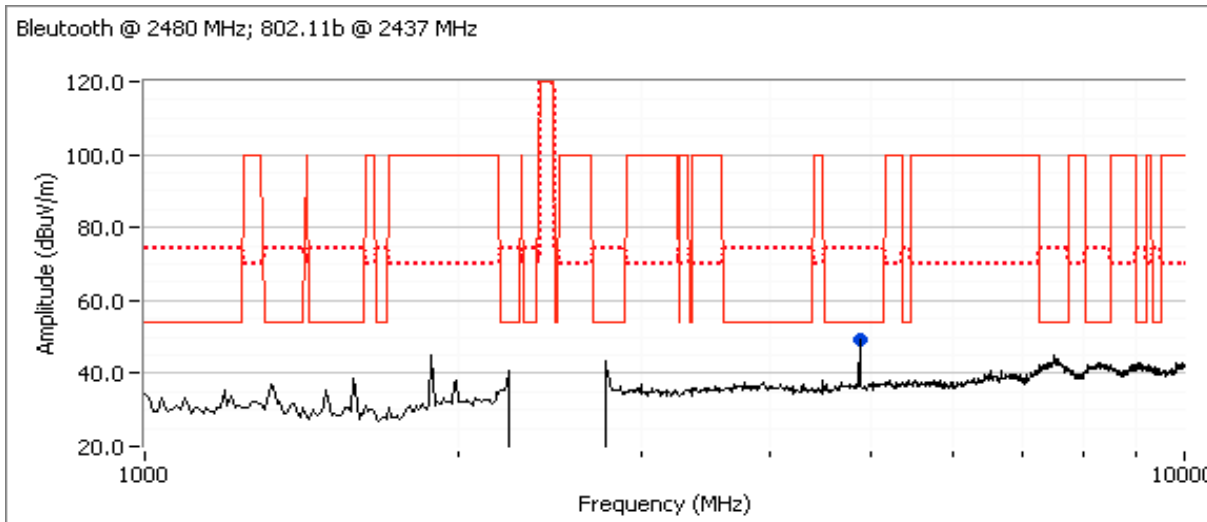

Preliminary Measurements (Peak versus average limit)

Frequency	Level	Pol	15.209/15.247		Detector	Azimuth	Height	Comments
MHz	dBuV/m	v/h	Limit	Margin	PK/QP/Avg	degrees	meters	
4873.820	49.5	V	54.0	-4.5	Peak	120	1.3	Note 1

Note 1: This is the second harmonic of the 802.11b signal and not an intermodulation product. Measurement of harmonics directly related to the 802.11 transmitter are provided in the 802.11 radiated spurious emissions test data.

Client:	Intel Corporation	Job Number:	J80397
Model:	Intel® Centrino® Wireless-N 1030 and Intel® Centrino® Wireless-N 130	T-Log Number:	T80458
		Account Manager:	Christine Krebill
Contact:	Steve Hackett		
Standard:	FCC.247, RSS-210 Issue 7	Class:	N/A

Spurious Radiated Emissions, 2 - 3GHz

Preliminary Scan at ~ 20cm from the product to identify potential signals (No preamplifier used for these scans)

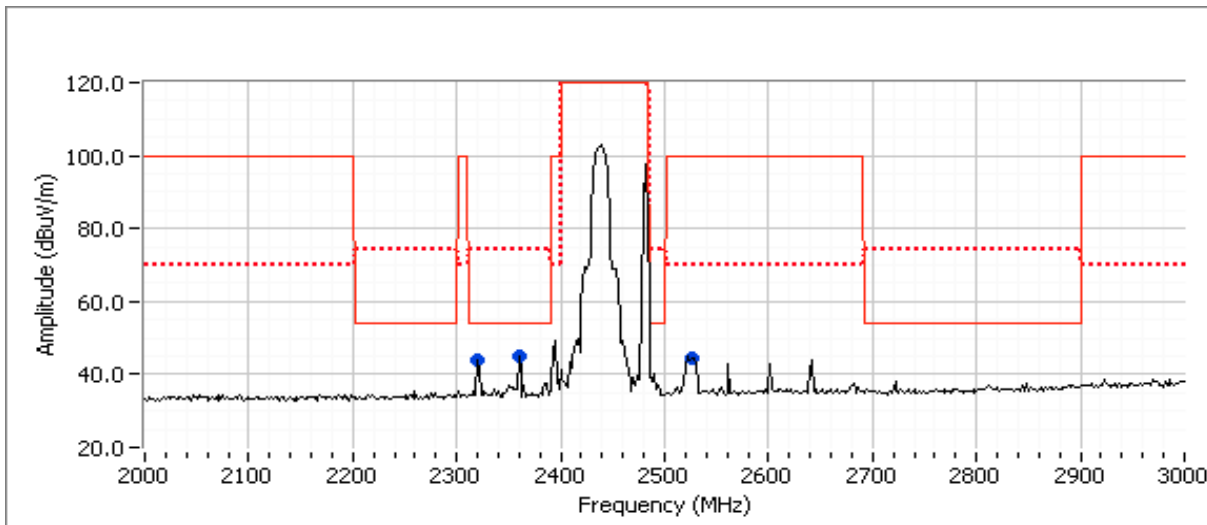

Preliminary measurements at ~ 20cm, RB=1MHz, VB=100kHz

Frequency MHz	Level dBuV/m	Pol v/h	15.209/15.247		Detector Pk/QP/Avg	Azimuth degrees	Height meters	Comments
			Limit	Margin				
2320.000	44.0	H	54.0	-10.0	Peak	150	1.0	
2360.000	45.0	H	54.0	-9.0	Peak	150	1.0	
2526.670	44.6	H	70.0	-25.4	Peak	150	1.0	

Final measurements at 3m

Frequency MHz	Level dBuV/m	Pol v/h	15.209/15.247		Detector Pk/QP/Avg	Azimuth degrees	Height meters	Comments
			Limit	Margin				
2360.030	50.5	H	54.0	-3.5	AVG	62	1.0	RB 1MHz;VB 10 Hz;Pk
2320.030	48.7	H	54.0	-5.3	AVG	26	1.0	RB 1MHz;VB 10 Hz;Pk
2359.750	57.5	H	74.0	-16.5	PK	62	1.0	RB 1MHz;VB 3MHz;Pk
2319.630	56.7	H	74.0	-17.3	PK	26	1.0	RB 1MHz;VB 3MHz;Pk

Note 2: For emissions in restricted bands, the limit of 15.209 was used. For all other emissions, the limit is -30dBc for peak measurements in a measurement bandwidth of 100kHz.

Client:	Intel Corporation	Job Number:	J80397
Model:	Intel® Centrino® Wireless-N 1030 and Intel® Centrino® Wireless-N 130	T-Log Number:	T80458
		Account Manager:	Christine Krebill
Contact:	Steve Hackett		
Standard:	FCC.247, RSS-210 Issue 7	Class:	N/A

Run # 9, Bluetooth/802.11bgn simultaneously: 1-10GHz, 802.11b mode @ 2462MHz Chain A, BT EDR @ 2440MHz Chain B

	Target (dBm)	Power Settings Measured (dBm)	Software Setting
Chain A	16.5	16.8	20.0
Chain B	7.0	1.5	8.0

Spurious Radiated Emissions, 1 - 10GHz excluding the allocated band:
Preamplifier and notch filter used for these scans

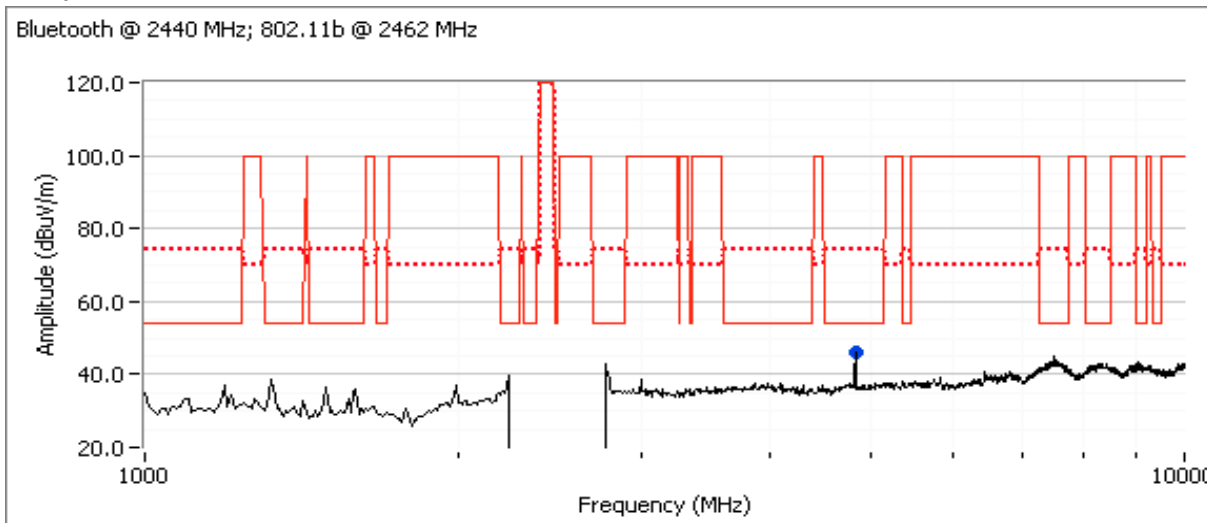

Preliminary Measurements (Peak versus average limit)

Frequency	Level	Pol	15.209/15.247		Detector	Azimuth	Height	Comments
MHz	dBuV/m	v/h	Limit	Margin	Pk/QP/Avg	degrees	meters	
4923.810	50.5	V	54.0	-3.5	Peak	110	1.6	Note 1

Note 1: This is the second harmonic of the 802.11b signal and not an intermodulation product. Measurement of harmonics directly related to the 802.11 transmitter are provided in the 802.11 radiated spurious emissions test data.

Client:	Intel Corporation	Job Number:	J80397
Model:	Intel® Centrino® Wireless-N 1030 and Intel® Centrino® Wireless-N 130	T-Log Number:	T80458
		Account Manager:	Christine Krebill
Contact:	Steve Hackett		
Standard:	FCC.247, RSS-210 Issue 7	Class:	N/A

Spurious Radiated Emissions, 2 - 3GHz

Preliminary Scan at ~ 20cm from the product to identify potential signals (No preamplifier used for these scans)

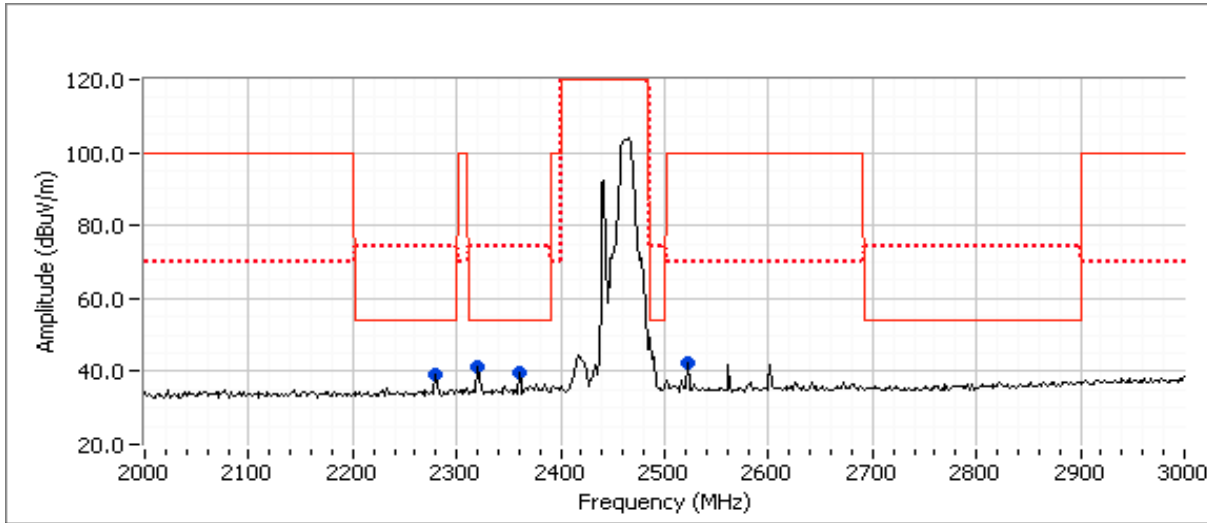

Preliminary measurements at ~ 20cm, RB=1MHz, VB=100kHz

Frequency	Level	Pol	15.209/15.247		Detector	Azimuth	Height	Comments
MHz	dBuV/m	v/h	Limit	Margin	Pk/QP/Avg	degrees	meters	
2280.000	39.1	H	54.0	-14.9	Peak	199	1.0	
2320.000	41.5	H	54.0	-12.5	Peak	199	1.0	
2360.000	39.5	H	54.0	-14.5	Peak	199	1.0	
2521.670	42.6	H	70.0	-27.4	Peak	199	1.0	

Final measurements at 3m

Frequency	Level	Pol	15.209/15.247		Detector	Azimuth	Height	Comments
MHz	dBuV/m	v/h	Limit	Margin	Pk/QP/Avg	degrees	meters	Setting
2320.000	46.1	H	54.0	-7.9	AVG	118	1.0	RB 1MHz;VB 10 Hz;Pk
2360.000	45.0	H	54.0	-9.0	AVG	360	1.0	RB 1MHz;VB 10 Hz;Pk
2280.050	44.9	H	54.0	-9.1	AVG	58	1.0	RB 1MHz;VB 10 Hz;Pk
2320.580	55.7	H	74.0	-18.3	PK	118	1.0	RB 1MHz;VB 3MHz;Pk
2360.120	55.6	H	74.0	-18.4	PK	360	1.0	RB 1MHz;VB 3MHz;Pk
2280.220	55.4	H	74.0	-18.6	PK	58	1.0	RB 1MHz;VB 3MHz;Pk

Note 2: For emissions in restricted bands, the limit of 15.209 was used. For all other emissions, the limit is -30dBc for peak measurements in a measurement bandwidth of 100kHz.