

**ELECTROMAGNETIC EMISSIONS COMPLIANCE REPORT  
INTENTIONAL RADIATOR CERTIFICATION TO  
FCC PART 15 SUBPART B & C REQUIREMENT**

OF

Wireless remote handset

MODEL No.: JLDK.18.04.03  
Serial Model: JLDK.18.04.02, JLDK.18.04.05, JLDK.18.04.06

FCC ID: PCU-JLDK-18-4

REPORT NO: EN140708024E

ISSUE DATE: August 04, 2014

Prepared for  
OKIN REFINED ELECTRIC TECHNOLOGY CO., LTD.  
Plant 4, No.410, Xinyonglian Road, Wangjiangjing Development Zone,  
Jiaxing Zhejiang China

Prepared by  
NINGBO EMTEK CO., LTD  
1F Building 4, 1177#, Lingyun Road, Ningbo National Hi-Tech Zone,  
Ningbo, Zhejiang, China  
TEL: 0086-574-27907998  
FAX: 0086-574-27721538

### VERIFICATION OF COMPLIANCE

Applicant:	OKIN REFINED ELECTRIC TECHNOLOGY CO., LTD. Plant 4, No.410, Xinyonglian Road, Wangjiangjing Development Zone, Jiaxing Zhejiang China
Product Description:	Wireless remote handset
Model Number:	JLDK.18.04.03
Serial Model:	JLDK.18.04.02, JLDK.18.04.05, JLDK.18.04.06 (Note: All the models are identical in interior structure and PCB, the only difference is the number of the buttons on the surface.)
File Number:	EN140708024E
Date of Test:	July 08, 2014 to August 04, 2014

#### **We hereby certify that:**

The above equipment was tested by NINGBO EMTEK CO., LTD. The test data, data evaluation, test procedures, and equipment configurations shown in this report were made in accordance with the procedures given in ANSI C63.4 (2009) and the energy emitted by the sample EUT tested as described in this report is in compliance with conducted and radiated emission limits of FCC Rules Part 15.249.

The test results of this report relate only to the tested sample identified in this report.

*Approved By*



---

*Andy.wang/Manager*  
**NINGBO EMTEK CO., LTD.**

## Table of Contents

<b>1. GENERAL INFORMATION.....</b>	<b>4</b>
1.1. Product Description.....	4
1.2. Related Submittal(s) / Grant (s) .....	4
1.3. Test Methodology .....	4
1.4. Special Accessories .....	4
1.5. Equipment Modifications.....	4
1.6. Test Facility.....	5
1.7. Measurement Uncertainty .....	5
<b>2. SYSTEM TEST CONFIGURATION .....</b>	<b>6</b>
2.1. EUT Configuration .....	6
2.2. EUT Exercise .....	6
2.3. Requirement for Compliance .....	6
2.4. Configuration of Tested System.....	7
2.5. Description of support units .....	8
<b>3. SUMMARY OF TEST RESULTS .....</b>	<b>9</b>
<b>4. DESCRIPTION OF TEST MODES.....</b>	<b>9</b>
<b>5. RADIATED EMISSION TEST .....</b>	<b>10</b>
5.1. Measurement Procedure.....	10
5.2. Measurement Equipment Used: .....	10
5.3. Test SET-UP.....	11
5.4. Radiated Measurement Result .....	11
5.5. Radiated Measurement Photos:.....	18
<b>6. BAND EDGES MEASUREMENT .....</b>	<b>19</b>
6.1. Standard Applicable .....	19
6.2. Measurement Procedure.....	19
6.3. Measurement Equipment .....	19
6.4. Test Setup.....	19
6.5. Test Results .....	19
<b>7. ANTENNA APPLICATION.....</b>	<b>21</b>
7.1. Standard Applicable .....	21
7.2. Antenna Construction .....	21

## 1. GENERAL INFORMATION

### 1.1. Product Description

The EUT is a short range, lower power, Details of technical specification, refers to the description in follows:

- a. Operation Frequency: 2406-2458MHz
- b. Number of Channel: 64
- c. Antenna Designation: PCB antenna
- d. Modulation: MSK
- e. Rated RF Output Power: 0dBm (Max)
- f. Power Supply: DC 4.5V

### 1.2. Related Submittal(s) / Grant (s)

This submittal(s) (test report) is intended for FCC ID: PCU-JLDK-18-4 filing to comply with Section 15.249 of the FCC Part 15 Subpart C Rules.

### 1.3. Test Methodology

Both conducted and radiated testing were performed according to the procedures in ANSI C63.4 -2009. Radiated testing was performed at an antenna to EUT distance 3 meters.

### 1.4. Special Accessories

Not available for this EUT intended for grant.

### 1.5. Equipment Modifications

Not available for this EUT intended for grant.

### 1.6. Test Facility

Site Description	
EMC Lab.	: Accredited by CNAS, 2014.1.21 The certificate is valid until 2017.1.20 The Laboratory has been assessed and proved to be in compliance with CNAS-CL01:2006 (identical to ISO/IEC 17025:2005) The Certificate Registration Number is L6666.  Accredited by FCC, June 18, 2014 The Certificate Registration Number is 463622.
Name of Firm	: NINGBO EMTEK CO., LTD.
Site Location	: 1F Building 4, 1177#, Lingyun Road, Ningbo National Hi-Tech Zone, Ningbo, Zhejiang, China

#### 30MHz~25GHz Radiated emission item subcontracted in Shenzhen Emtek:

EMC Lab.	The Certificate Registration Number is 709623.
Name of Firm	: SHENZHEN EMTEK CO., LTD.
Site Location	: Bldg 69, Majialong Industry Zone, Nanshan District, Shenzhen, Guangdong, China

### 1.7. Measurement Uncertainty

Radiated Emission Uncertainty (3m Chamber)	: 3.7dB (30M~26GHz Polarize: H) 3.6dB (30M~26GHz Polarize: V)
--------------------------------------------	------------------------------------------------------------------

## 2. SYSTEM TEST CONFIGURATION

### 2.1.EUT Configuration

The EUT configuration for testing is installed on RF field strength measurement to meet the Commissions requirement and operating in a manner which intends to maximize its emission characteristics in a continuous normal application.

### 2.2.EUT Exercise

The EUT (Wireless remote handset) has been tested under Normal Operating and standby condition. No software used to control the EUT for staying in continuous transmitting and receiving mode for testing.

### 2.3.Requirement for Compliance

#### 2.3.1.Conducted Emissions (Not applicable in the report)

According to §15.207, For intentional radiator device is designed to be connected to the public utility (AC) power line, the radio frequency voltage that is conducted back onto the AC power line on any frequency or frequencies within the band 150 kHz to 30 MHz shall not exceed the limits in the following table, as measured using a 50  $\mu$ H/50 ohms line impedance stabilization network (LISN). Compliance with the provisions of this paragraph shall be based on the measurement of the radio frequency voltage between each power line and ground at the power terminal.

Frequency(MHz)	Quasi-peak	Average
0.15-0.5	66-56	56-46
0.5-5.0	56	46
5.0-30.0	60	50

Note: 1. The lower limit shall apply at the transition frequencies  
2.The limit decreases in line with the logarithm of the frequency in the range of 0.15 to 0.50MHz.

2.3.2.Radiated Emissions

(a) FCC Part 15, Subpart C Section 15.209 limit of radiated emission for frequency below 1000GHz. The emissions from an intentional radiator shall not exceed the field strength level specified in the following table:

Frequency (MHz)	Field strength $\mu\text{V/m}$	Distance(m)	Field strength at 3m $\text{dB}\mu\text{V/m}$
30-88	100	3	40.0
88-216	150	3	43.5
216-960	200	3	46.0
Above 960	500	3	54.0

Remark:

1. Emission level in  $\text{dB}\mu\text{V/m}=20 \log (\mu\text{V/m})$
2. Measurement was performed at an antenna to the closed point of EUT distance of meters.

(b) FCC Part 15, Section 15.35(b) limit of radiated emission for frequency above 1000MHz

Frequency(MHz)	$\text{dB}\mu\text{V/m(at 3m)}$	
	PEAK	AVERAGE
Above 1000	74.0	54.0

(c) FCC Part 15, Subpart C Section 15.249(a). The field strength of emissions from intentional radiators operated within these frequency bands shall comply with the following:

Frequency(MHz)	Filed Strength of Fundamental(at 3m)		Filed Strength of Harmonics (at 3m)	
	PEAK	AVERAGE	PEAK	AVERAGE
902-928	114.0	94.0	74.0	54.0
2400-2483.5	114.0	94.0	74.0	54.0
5725-5875	114.0	94.0	74.0	54.0
24000-24250	128.0	108.0	88.0	68.0

(d) Band edge

Emission radiated outside of the specified frequency bands, except for harmonics, shall be attenuated by at least 50dB below the level of the fundamental or to the general radiated emission limits in section 15.209, whichever is the lesser attenuation.

Frequency Range(MHz)	Limit( $\text{dB}\mu\text{V/m}$ )	
	Peak	AV
902-928	74.0	54.0
2400-2483.5		
5725-5850		
24000-24250		

2.3.3.Antenna Requirement

For intentional device, according to §15.203, an intentional radiator shall be designed to ensure that no antenna other than that furnished by the responsible party shall be used with the device.

2.4.Configuration of Tested System

EUT
-----

## 2.5. Description of support units

The EUT has been tested as an independent unit together with other necessary accessories or support units. The following support units or accessories were used to form a representative test configuration during the tests.

Item	Equipment	Mfr/Brand	Model/Type No.	FCC ID	Series No.	Note
1.	Wireless remote handset	OKIN	JLDK.18.04.03	PCU-JLDK-18-4	N/A	EUT
Note: Unless otherwise denoted as EUT in 『Remark』 column , device(s) used in tested system is a support equipment.						



### 3. SUMMARY OF TEST RESULTS

FCC Rules	Description Of Test	Result
§ 15.249(a), § 15.249(d) § 15.249(e), § 15.209	Radiated Emission	Compliant
§15.249	Band Edge	Compliant
§ 15.203	Antenna Requirement	Compliant

### 4. DESCRIPTION OF TEST MODES

The RF frequency is decided by the status of the DIPSWITCH, in which there are 6 bits and every bit has 2 status of ON/OFF, total  $64(2^6)$  different frequencies can be set.

Test Mode	Frequency(MHz)
Mode 1	2406.999
Mode 2	2431.792
Mode 3	2457.386

## 5. RADIATED EMISSION TEST

### 5.1.Measurement Procedure

- a. All measurements were made at 3 meters.
- b. The EUT was placed on the top of a rotating table 0.8 meters above the ground at a 3m meter test site. The table was rotated 360 degrees to determine the position of the highest radiation.
- c. The height of the equipment or of the substitution antenna shall be 0.8 m; the height of the test antenna shall vary between 1 m to 4 m. Both horizontal and vertical polarizations of the antenna are set to make the measurement.
- d. The initial step in collecting conducted emission data is a spectrum analyzer peak detector mode pre-scanning the measurement frequency range. Significant peaks are then marked and then Quasi Peak detector mode re-measured.
- e. If the Peak Mode measured value compliance with and lower than Quasi Peak Mode Limit, the EUT shall be deemed to meet QP Limits and then no additional QP Mode measurement performed.
- f. For the actual test configuration, please refer to the related Item –EUT Test Photos.

The frequency range from 30MHz to 1000MHz was pre-scanned with a peak detector (RBW=100kHz, VBW=300kHz) and all final readings of measurement from Test Receiver are Quasi-Peak values(Quasi Peak detector used with a bandwidth of 120 kHz).

The frequency range above 1GHz the measuring instrument use RBW=1 MHz and VBW=3 MHz with Peak Detector for Peak Values, and use RBW=1 MHz and VBW=10 Hz with Peak Detector for Average Values.

### 5.2.Measurement Equipment Used:

Item	Equipment	Manufacturer	Model No.	Serial No.	Last Cal.	Cal. Interval
1.	EMI Test Receiver	Rohde & Schwarz	ESU	1302.6005.26	05/17/2014	1 Year
2.	Pre-Amplifier	HP	8447D	2944A07999	05/17/2014	1 Year
3.	Pre-Amplifier	A.H.	PAM-0126	1415261	05/17/2014	1 Year
4.	Bilog Antenna	Schwarzbeck	VULB9163	142	05/17/2014	1 Year
5.	Loop Antenna	Schwarzbeck	FMZB 1519	1519-012	05/17/2014	1 Year
6.	Horn Antenna	Schwarzbeck	BBHA 9170	BBHA9170399	05/17/2014	1 Year
7.	Horn Antenna	Schwarzbeck	BBHA 9120	D143	05/17/2014	1 Year
8.	Cable	Schwarzbeck	AK9513	ACRX1	05/17/2014	1 Year
9.	Cable	Rosenberger	N/A	FP2RX2	05/17/2014	1 Year
10.	Cable	Schwarzbeck	AK9513	CRPX1	05/17/2014	1 Year
11.	Cable	Schwarzbeck	AK9513	CRRX2	05/17/2014	1 Year

### 5.3. Test SET-UP

(a) Radiated Emission Test Set-Up, Frequency Below 30MHz

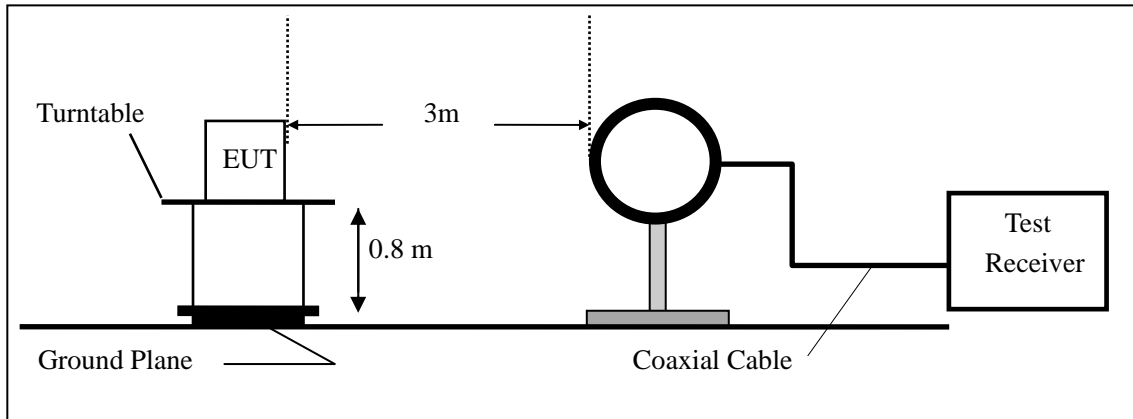

(b) Radiated Emission Test Set-Up, Frequency Below 1000MHz

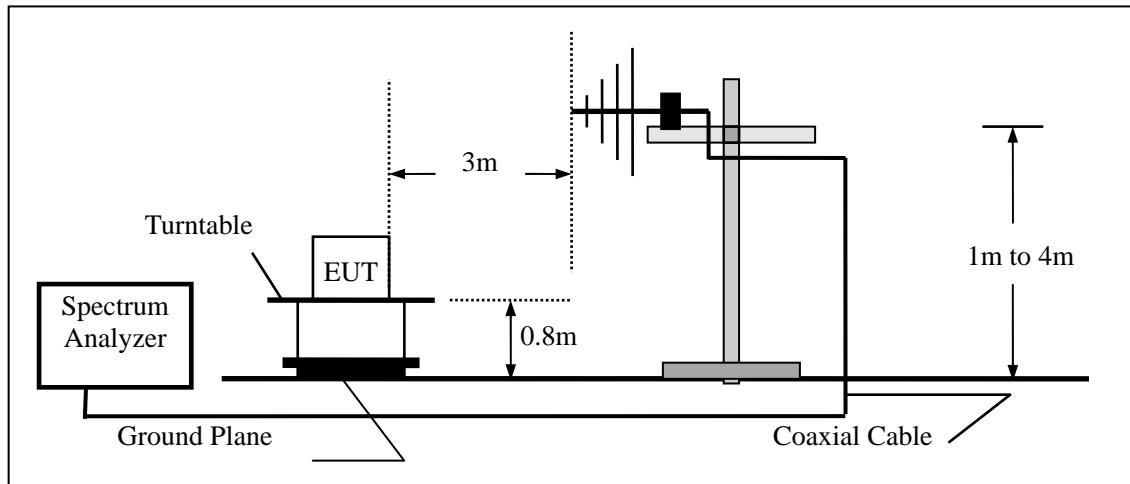

(c) Radiated Emission Test Set-Up, Frequency Above 1000MHz

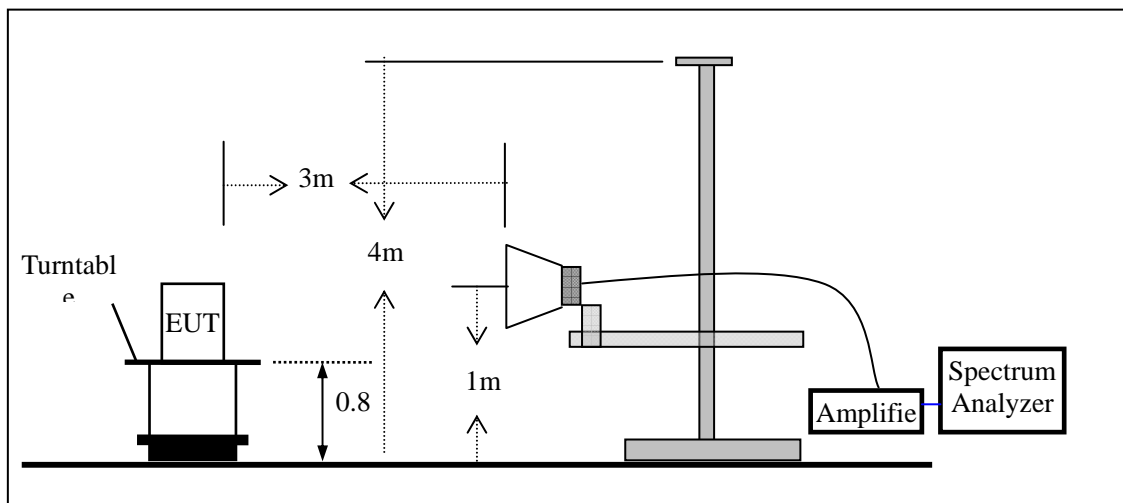

### 5.4. Radiated Measurement Result

**Pass**

*(For range 9KHz~30MHz, The measured value is really too low to be recorded.)*

Below 1000MHz:

Mode 1: Vertical

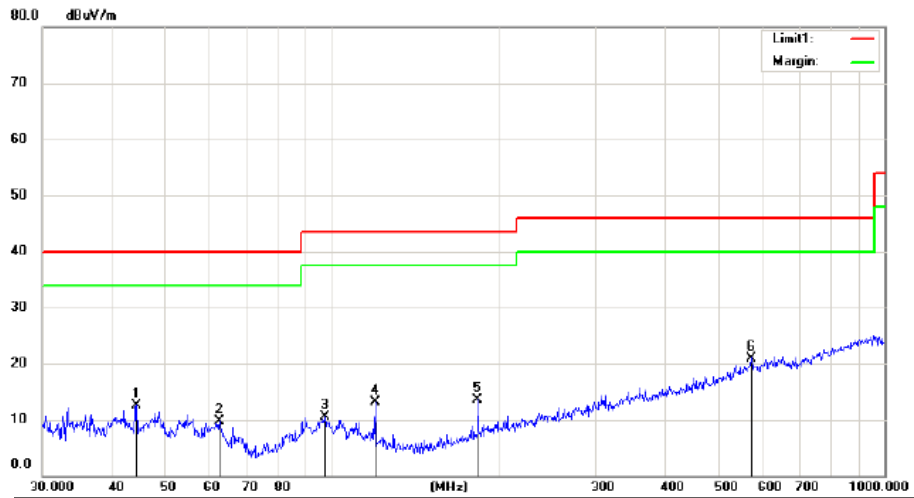

No.	Mk.	Freq.	Reading Level	Correct Factor	Measurement	Limit	Over	Antenna Height	Table Degree	
		MHz	dBuV	dB	dBuV/m	dBuV/m	dB	cm	degree	Comment
1		44.2751	33.32	-20.72	12.60	40.00	-27.40	QP		
2		62.6505	32.30	-22.50	9.80	40.00	-30.20	QP		
3		97.1148	31.35	-20.85	10.50	43.50	-33.00	QP		
4		119.8555	36.37	-23.27	13.10	43.50	-30.40	QP		
5		183.8440	36.06	-22.46	13.60	43.50	-29.90	QP		
6	*	574.6258	31.69	-10.69	21.00	46.00	-25.00	QP		

Mode 1: Horizontal

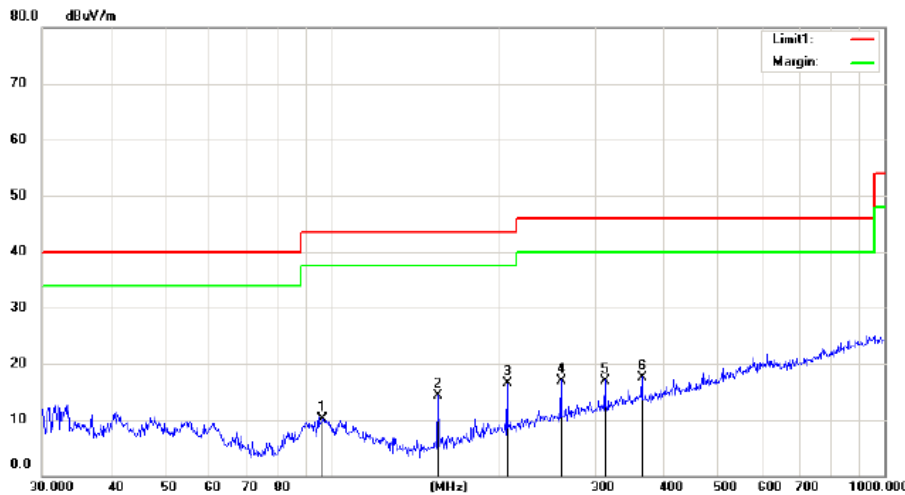

No.	Mk.	Freq.	Reading Level	Correct Factor	Measurement	Limit	Over	Antenna Height	Table Degree	
		MHz	dBuV	dB	dBuV/m	dBuV/m	dB	cm	degree	Comment
1		96.4362	30.98	-20.88	10.10	43.50	-33.40	QP		
2		155.9101	38.83	-24.43	14.40	43.50	-29.10	QP		
3	*	207.8501	37.81	-21.31	16.50	43.50	-27.00	QP		
4		260.1444	36.38	-19.38	17.00	46.00	-29.00	QP		
5		312.1794	34.70	-17.70	17.00	46.00	-29.00	QP		
6		364.2595	33.72	-16.12	17.60	46.00	-28.40	QP		

Mode 2: Vertical

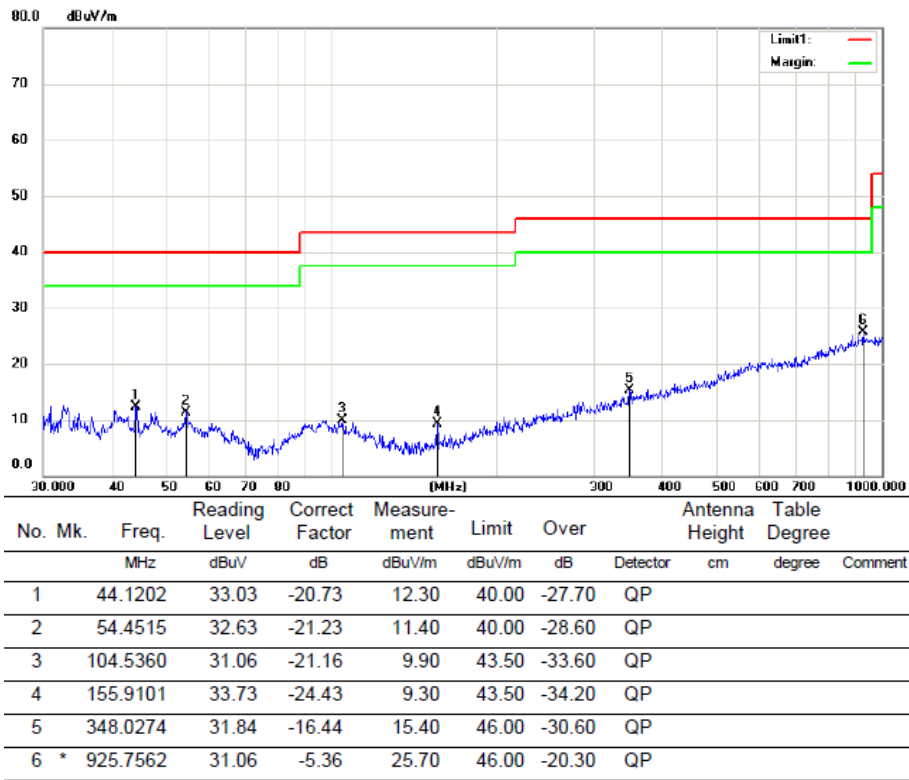

Mode 2: Horizontal

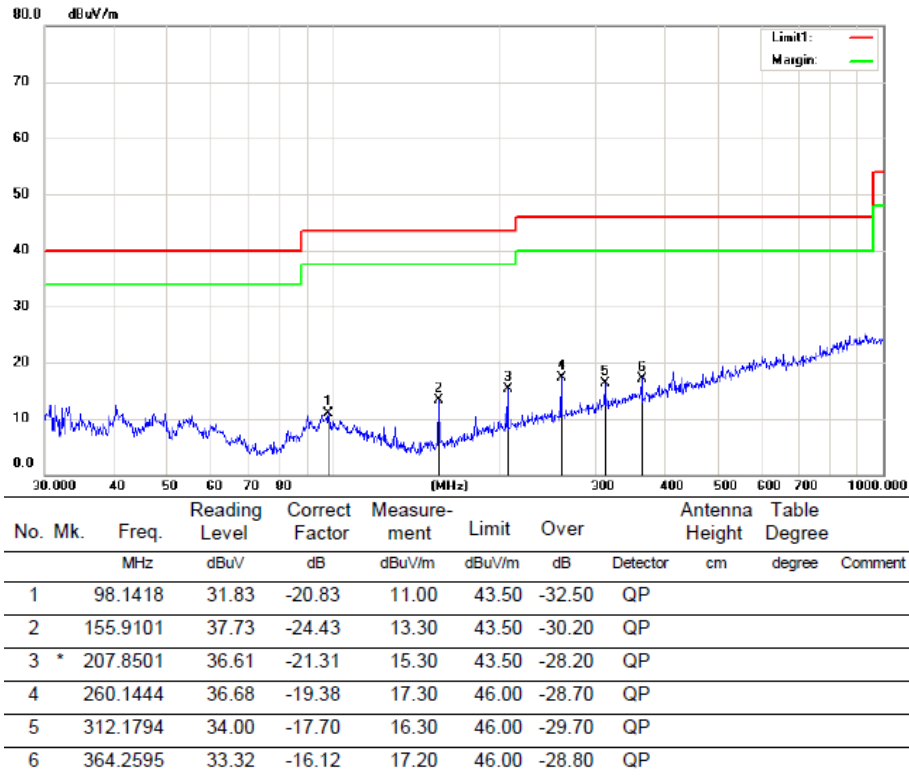

Mode 3: Horizontal

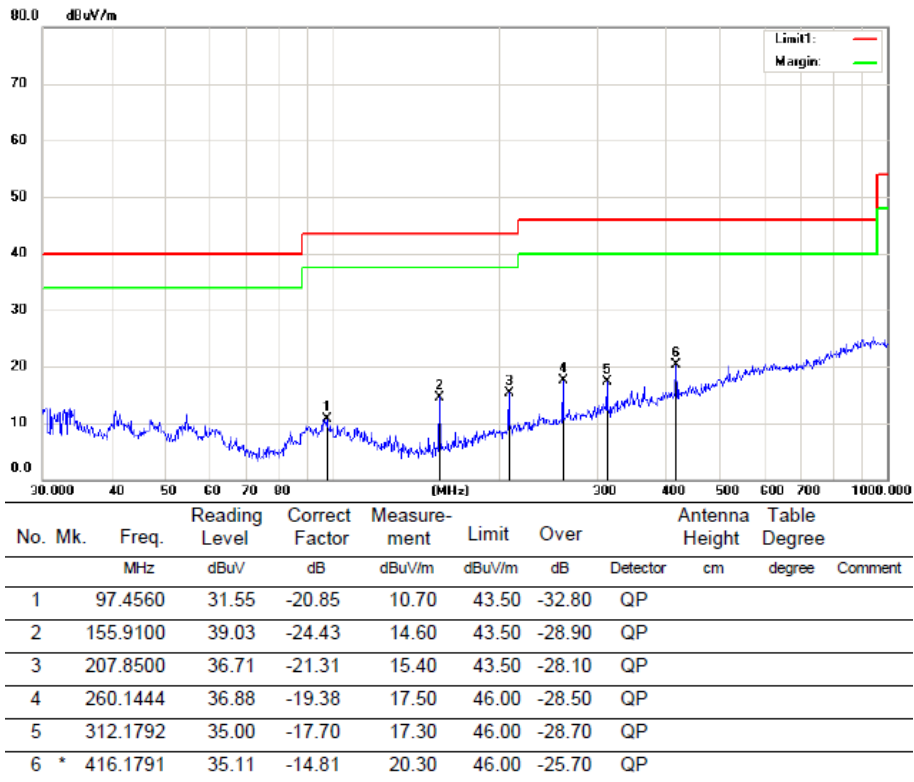

Mode 3: Vertical

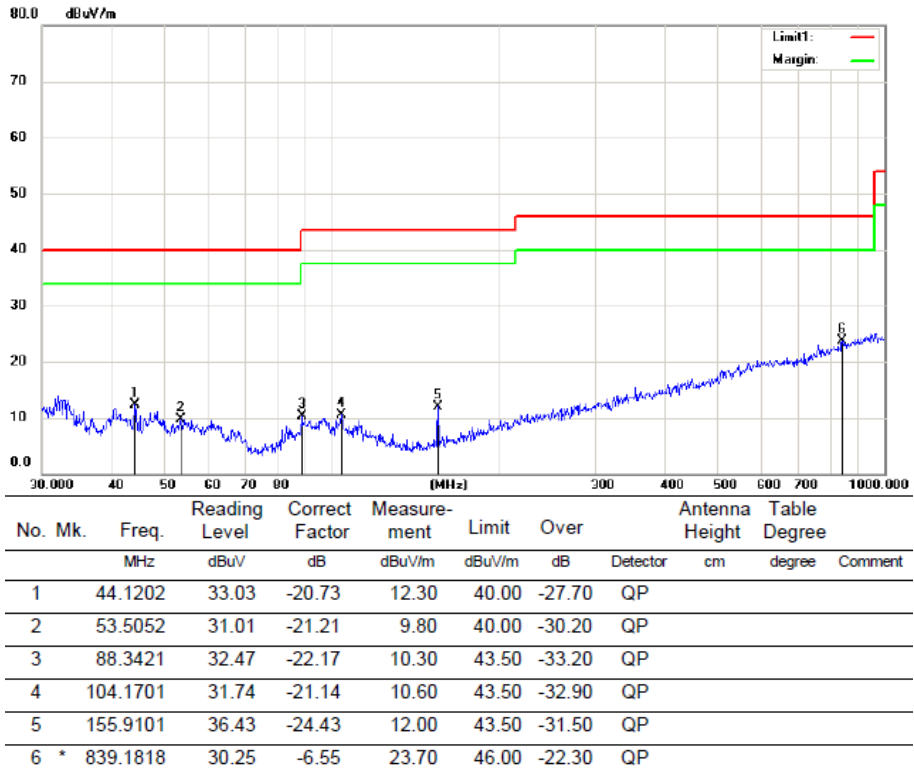

Above 1000MHz:

Operation Mode: Mode 1                      Test Date : August 04, 2014  
 Test Result: PASS                              Temperature : 24 °C  
 Measured Distance: 3m                      Humidity : 53 %  
 Test By: Joe.xia

Freq. (MHz)	Ant.Pol .	Emission Level (dBuV)		Limit 3m (dBuV/m)		Margin(dB)	
		H/V	PK	AV	PK	AV	PK
1612.000	V	42.13	30.76	74.00	54.00	-31.87	-23.24
2406.999	V	84.14	76.38	114.00	94.00	-29.86	-17.62
3142.000	V	44.38	31.94	74.00	54.00	-29.62	-22.06
4825.000	V	46.61	33.82	74.00	54.00	-27.39	-20.18
6814.000	V	49.62	30.97	74.00	54.00	-24.38	-23.03
8514.000	V	52.94	32.67	74.00	54.00	-21.06	-21.33
1204.000	H	41.72	30.61	74.00	54.00	-32.28	-23.39
1612.000	H	42.60	31.97	74.00	54.00	-31.40	-22.03
2406.999	H	84.06	70.96	114.00	94.00	-29.94	-23.04
3142.000	H	44.52	32.67	74.00	54.00	-29.48	-21.33
4808.000	H	49.17	32.98	74.00	54.00	-24.83	-21.02
6899.000	H	50.45	33.67	74.00	54.00	-23.55	-20.33

**Note:** (1) All Readings are Peak Value and AV.  
 (2) Emission Level= Reading Level+Probe Factor +Cable Loss

Operation Mode: Mode 2                      Test Date : August 04, 2014  
 Test Result: PASS                              Temperature : 24 °C  
 Measured Distance: 3m                      Humidity : 53 %  
 Test By: Joe.xia

Freq. (MHz)	Ant.Pol .	Emission Level (dBuV)		Limit 3m (dBuV/m)		Margin(dB)	
		H/V	PK	AV	PK	AV	PK
1595.000	V	41.93	30.81	74.00	54.00	-32.07	-23.19
2411.000	V	43.69	30.68	74.00	54.00	-30.31	-23.32
2431.792	V	80.14	71.64	114.00	94.00	-33.86	-22.36
2802.000	V	44.71	31.76	74.00	54.00	-29.29	-22.24
4859.000	V	46.61	31.97	74.00	54.00	-27.39	-22.03
7392.000	V	51.06	32.97	74.00	54.00	-22.94	-21.03
8922.000	V	53.37	33.64	74.00	54.00	-20.63	-20.36
1595.000	H	41.58	30.97	74.00	54.00	-32.42	-23.03
2411.000	H	44.18	31.67	74.00	54.00	-29.82	-22.33
2431.792	H	83.80	71.52	114.00	94.00	-30.20	-22.48
3159.000	H	44.77	31.80	74.00	54.00	-29.23	-22.20
4876.000	H	51.45	31.97	74.00	54.00	-22.55	-22.03
6321.000	H	47.34	32.67	74.00	54.00	-26.66	-21.33
7460.000	H	51.06	33.67	74.00	54.00	-22.94	-20.33

**Note:** (1) All Readings are Peak Value and AV.  
 (2) Emission Level= Reading Level+Probe Factor +Cable Loss



Operation Mode: Mode 3                      Test Date : August 04, 2014  
 Test Result: PASS                              Temperature : 24 °C  
 Measured Distance: 3m                      Humidity : 53 %  
 Test By: Joe.xia

Freq. (MHz)	Ant.Pol .	Emission Level (dBuV)		Limit 3m (dBuV/m)		Margin(dB)	
		H/V	PK	AV	PK	AV	PK
1221.000	V	41.44	30.67	74.00	54.00	-32.56	-23.33
2411.000	V	43.81	31.64	74.00	54.00	-30.19	-22.36
2457.386	V	84.35	70.94	114.00	94.00	-29.65	-23.06
3125.000	V	44.33	32.90	74.00	54.00	-29.67	-21.10
4026.000	V	44.88	31.97	74.00	54.00	-29.12	-22.03
4910.000	V	47.60	32.68	74.00	54.00	-26.40	-21.32
6831.000	V	50.59	33.07	74.00	54.00	-23.41	-20.93
1629.000	H	41.82	30.81	74.00	54.00	-32.18	-23.19
2457.386	H	84.35	71.84	114.00	94.00	-29.65	-22.16
2785.000	H	45.42	33.08	74.00	54.00	-28.58	-20.92
3159.000	H	45.78	32.68	74.00	54.00	-28.22	-21.32
4519.000	H	43.89	31.97	74.00	54.00	-30.11	-22.03
7086.000	H	50.22	32.68	74.00	54.00	-23.78	-21.32
8973.000	H	52.99	33.60	74.00	54.00	-21.01	-20.40

**Note:** (1) All Readings are Peak Value and AV.  
 (2) Emission Level= Reading Level+Probe Factor +Cable Loss

### 5.5.Radiated Measurement Photos:

#### 30M~1000MHz:



#### Above 1000MHz:



## 6. BAND EDGES MEASUREMENT

### 6.1. Standard Applicable

According to 15.249(d), out band emission except for harmonics shall be comply with §15.209 or at least attenuated by 50 dB below the level of the fundamental.

### 6.2. Measurement Procedure

- a. The EUT was placed on the top of a rotating table 0.8 meters above the ground at a 3m meter test site. The table was rotated 360 degrees to determine the position of the highest radiation. The height of the test antenna shall vary between 1 m to 4 m. Both horizontal and vertical polarizations of the antenna are set to make the measurement.
- b. Spectrum Setting :  
Peak: RBW=1MHz, VBW=3MHz, Sweep=Auto  
Average: RBW=1MHz, VBW=3MHz, Sweep=Auto

### 6.3. Measurement Equipment

Same as 5.2 Radiated Emission Measurement.

### 6.4. Test Setup

Same as 5.3 Radiated Emission Measurement.

### 6.5. Test Results

**Pass**

The test plots as following:

Lower band edge

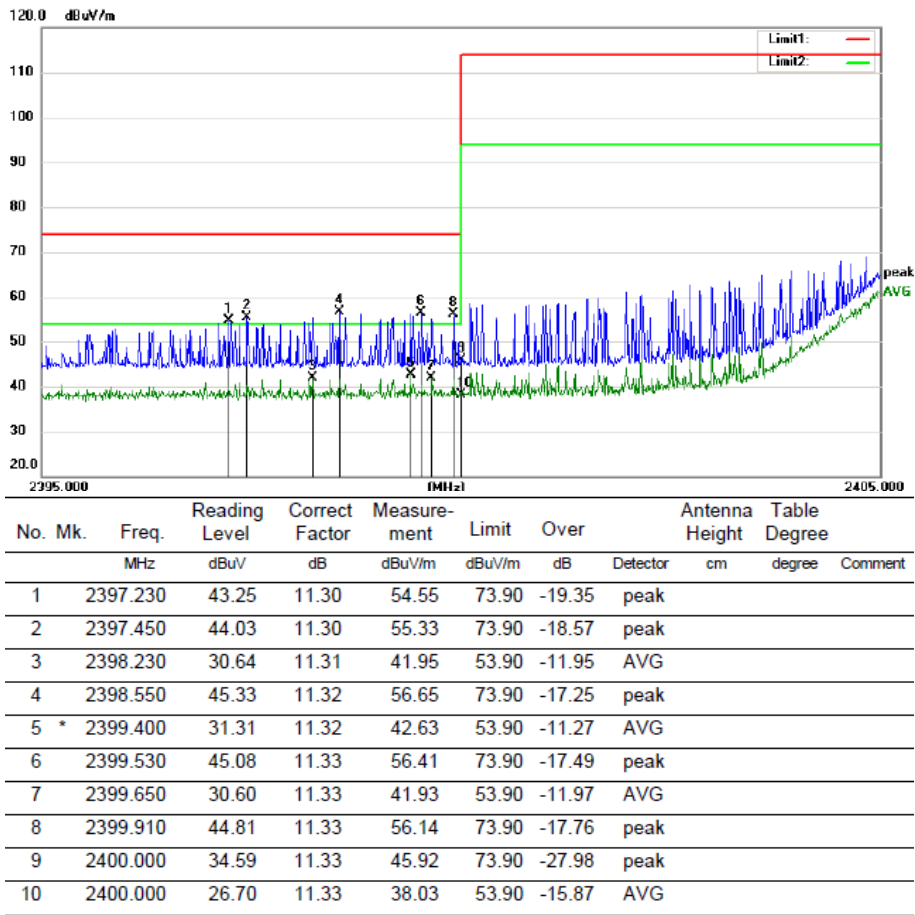

Upper band edge

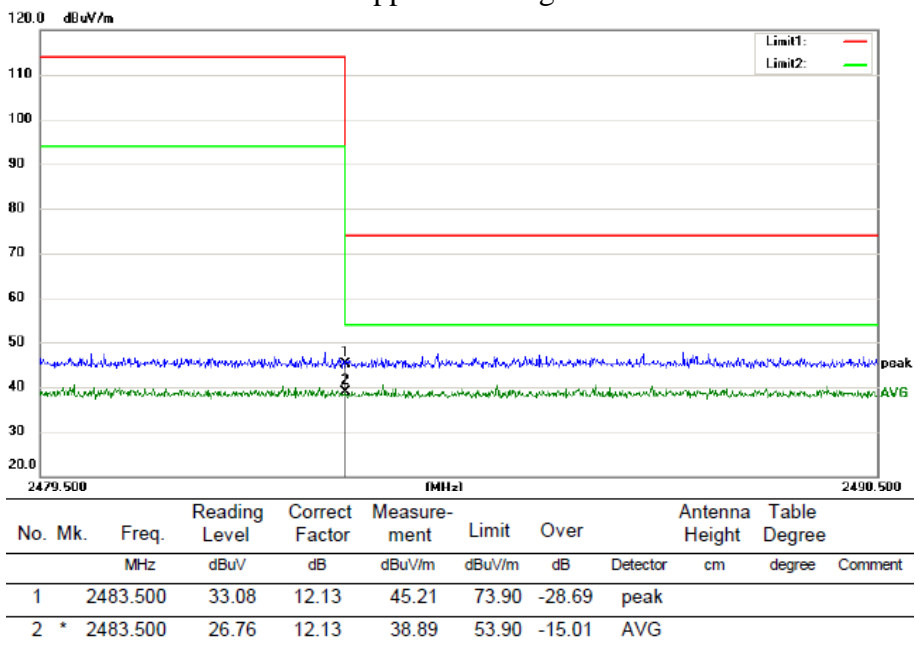

## **7. ANTENNA APPLICATION**

### **7.1. Standard Applicable**

According to §15.203, an intentional radiator shall be designed to ensure that no antenna other than that furnished by the responsible party shall be used with the device.

### **7.2. Antenna Construction**

The EUT'S antenna (PCB antenna) is permanently integrated on the main EUT, no consideration of replacement.