

**ELECTROMAGNETIC EMISSIONS COMPLIANCE REPORT
INTENTIONAL RADIATOR CERTIFICATION TO
FCC PART 15 SUBPART B & C REQUIREMENT**

OF

Wireless remote handset

MODEL No.: JLDK.18.01

FCC ID: PCU-JLDK-18-1

REPORT NO: EN130503006E

ISSUE DATE: May 30, 2013

Prepared for
OKIN REFINED ELECTRIC TECHNOLOGY CO., LTD.
Plant 4, No.410, Xinyonglian Road, Wangjiangjing Development Zone,
Jiaxing Zhejiang China

Prepared by
NINGBO EMTEK CO., LTD
1F Building 4, 1177#, Lingyun Road, Ningbo National Hi-Tech Zone,
Ningbo, Zhejiang, China
TEL: 0086-574-27907998
FAX: 0086-574-27721538

VERIFICATION OF COMPLIANCE

Applicant:	OKIN REFINED ELECTRIC TECHNOLOGY CO., LTD. Plant 4, No.410, Xinyonglian Road, Wangjiangjing Development Zone, Jiaxing Zhejiang China
Product Description:	Wireless remote handset
Model Number:	JLDK.18.01
File Number:	EN130503006F
Date of Test:	May 06, 2013 to May 27, 2013

We hereby certify that:

The above equipment was tested by NINGBO EMTEK CO., LTD. The test data, data evaluation, test procedures, and equipment configurations shown in this report were made in accordance with the procedures given in ANSI C63.4 (2009) and the energy emitted by the sample EUT tested as described in this report is in compliance with conducted and radiated emission limits of FCC Rules Part 15.249.

The test results of this report relate only to the tested sample identified in this report.

Approved By



Andy.wang/Manager
NINGBO EMTEK CO., LTD.

Table of Contents

1. GENERAL INFORMATION.....	4
1.1. Product Description.....	4
1.2. Related Submittal(s) / Grant (s)	4
1.3. Test Methodology	4
1.4. Special Accessories	4
1.5. Equipment Modifications.....	4
1.6. Test Facility.....	5
1.7. Measurement Uncertainty	5
2. SYSTEM TEST CONFIGURATION	6
2.1. EUT Configuration	6
2.2. EUT Exercise	6
2.3. Requirement for Compliance	6
2.4. Configuration of Tested System.....	8
2.5. Description of support units.....	8
3. SUMMARY OF TEST RESULTS	9
4. DESCRIPTION OF TEST MODES.....	9
5. RADIATED EMISSION TEST	10
5.1. Measurement Procedure.....	10
5.2. Measurement Equipment Used:	10
5.3. Test SET-UP	10
5.4. Radiated Measurement Result	12
5.5. Radiated Measurement Photos:.....	18
6. BAND EDGES MEASUREMENT.....	20
6.1. Standard Applicable	20
6.2. Measurement Procedure.....	20
6.3. Measurement Equipment	20
6.4. Test Setup.....	20
6.5. Test Results	20
7. ANTENNA APPLICATION.....	23
7.1. Standard Applicable	23
7.2. Antenna Construction	23

1. GENERAL INFORMATION

1.1.Product Description

The EUT is a short range, lower power, Details of technical specification, refers to the description in follows:

- a. Operation Frequency: 2406-2458MHz
- b. Number of Channel: 64
- c. Antenna Designation: PCB antenna
- d. Modulation: MSK
- e. Rated RF Output Power: 0dBm (Max)
- f. Power Supply: DC 4.5V

1.2.Related Submittal(s) / Grant (s)

This submittal(s) (test report) is intended for FCC ID: PCU-JLDK-18-1 filing to comply with Section 15.249 of the FCC Part 15 Subpart C Rules.

1.3.Test Methodology

Both conducted and radiated testing were performed according to the procedures in ANSI C63.4 -2009. Radiated testing was performed at an antenna to EUT distance 3 meters.

1.4.Special Accessories

Not available for this EUT intended for grant.

1.5.Equipment Modifications

Not available for this EUT intended for grant.

1.6. Test Facility

Site Description	
EMC Lab.	: Accredited by FCC, June 14, 2011 The Certificate Registration Number is 463622.
	Accredited by Industry Canada, May 2, 2011 The Certificate Registration Number is 46405-9469..
Name of Firm	: NINGBO EMTEK CO., LTD.
Site Location	: 1F Building 4, 1177#, Lingyun Road, Ningbo National Hi-Tech Zone, Ningbo, Zhejiang, China

30MHz~26GHz Radiated emission item Subcontracted in Shenzhen Emtek:

EMC Lab.	The Certificate Registration Number is 709623.
Name of Firm	: SHENZHEN EMTEK CO., LTD.
Site Location	: Bldg 69, Majialong Industry Zone, Nanshan District, Shenzhen, Guangdong, China

1.7. Measurement Uncertainty

Radiated Emission Uncertainty	: 3.7dB (30M~26GHz Polarize: H)
(3m Chamber)	3.6dB (30M~26GHz Polarize: V)

2. SYSTEM TEST CONFIGURATION

2.1.EUT Configuration

The EUT configuration for testing is installed on RF field strength measurement to meet the Commissions requirement and operating in a manner which intends to maximize its emission characteristics in a continuous normal application.

2.2.EUT Exercise

The EUT (Wireless remote handset) has been tested under Normal Operating and standby condition. No software used to control the EUT for staying in continuous transmitting and receiving mode for testing.

2.3.Requirement for Compliance

2.3.1.Conducted Emissions (Not apply in the report)

According to §15.207, For intentional radiator device is designed to be connected to the public utility (AC) power line, the radio frequency voltage that is conducted back onto the AC power line on any frequency or frequencies within the band 150 kHz to 30 MHz shall not exceed the limits in the following table, as measured using a 50 μ H/50 ohms line impedance stabilization network (LISN). Compliance with the provisions of this paragraph shall be based on the measurement of the radio frequency voltage between each power line and ground at the power terminal.

Frequency(MHz)	Quasi-peak	Average
0.15-0.5	66-56	56-46
0.5-5.0	56	46
5.0-30.0	60	50

Note: 1. The lower limit shall apply at the transition frequencies
2.The limit decreases in line with the logarithm of the frequency in the range of 0.15 to 0.50MHz.

2.3.2.Radiated Emissions

(a) FCC Part 15, Subpart C Section 15.209 limit of radiated emission for frequency below 1000GHz. The emissions from an intentional radiator shall not exceed the field strength level specified in the following table:

Frequency (MHz)	Field strength $\mu\text{V/m}$	Distance(m)	Field strength at 3m $\text{dB}\mu\text{V/m}$
30-88	100	3	40.0
88-216	150	3	43.5
216-960	200	3	46.0
Above 960	500	3	54.0

Remark:

1. Emission level in $\text{dB}\mu\text{V/m}=20 \log (\mu\text{V/m})$
2. Measurement was performed at an antenna to the closed point of EUT distance of meters.

(b) FCC Part 15, Section 15.35(b) limit of radiated emission for frequency above 1000MHz

Frequency(MHz)	$\text{dB}\mu\text{V/m(at 3m)}$	
	PEAK	AVERAGE
Above 1000	74.0	54.0

(c) FCC Part 15, Subpart C Section 15.249(a). The field strength of emissions from intentional radiators operated within these frequency bands shall comply with the following:

Frequency(MHz)	Filed Strength of Fundamental(at 3m)		Filed Strength of Harmonics (at 3m)	
	PEAK	AVERAGE	PEAK	AVERAGE
902-928	114.0	94.0	74.0	54.0
2400-2483.5	114.0	94.0	74.0	54.0
5725-5875	114.0	94.0	74.0	54.0
24000-24250	128.0	108.0	88.0	68.0

(d) Band edge

Emission radiated outside of the specified frequency bands, except for harmonics, shall be attenuated by at least 50dB below the level of the fundamental or to the general radiated emission limits in section 15.209, whichever is the lesser attenuation.

Frequency Range(MHz)	Limit($\text{dB}\mu\text{V/m}$)	
	Peak	AV
902-928	74.0	54.0
2400-2483.5		
5725-5850		
24000-24250		

2.3.3.Antenna Requirement

For intentional device, according to §15.203, an intentional radiator shall be designed to ensure that no antenna other than that furnished by the responsible party shall be used with the device.

2.4. Configuration of Tested System

EUT

2.5. Description of support units

The EUT has been tested as an independent unit together with other necessary accessories or support units. The following support units or accessories were used to form a representative test configuration during the tests.

Item	Equipment	Mfr/Brand	Model/Type No.	FCC ID	Series No.	Note
1.	Wireless remote handset	OKIN	JLDK.18.01	PCU-JLDK-18-1	N/A	EUT

Note: Unless otherwise denoted as EUT in 『Remark』 column , device(s) used in tested system is a support equipment.

3. SUMMARY OF TEST RESULTS

FCC Rules	Description Of Test	Result
§ 15.249(a), § 15.249(d) § 15.249(e), § 15.209	Radiated Emission	Compliant
§15.249	Band Edge	Compliant
§ 15.203	Antenna Requirement	Compliant

4. DESCRIPTION OF TEST MODES

The RF frequency is decided by the status of the DIPSWITCH, in which there are 6 bits and every bit has 2 status of ON/OFF, total 64(2⁶) different frequencies can be set.

Test Mode	Frequency(MHz)
Mode 1	2406.999
Mode 2	2431.792
Mode 3	2457.386

5. RADIATED EMISSION TEST

5.1.Measurement Procedure

- a. All measurements were made at 3 meters.
- b. The EUT was placed on the top of a rotating table 0.8 meters above the ground at a 3m meter open area test site. The table was rotated 360 degrees to determine the position of the highest radiation.
- c. The height of the equipment or of the substitution antenna shall be 0.8 m; the height of the test antenna shall vary between 1 m to 4 m. Both horizontal and vertical polarizations of the antenna are set to make the measurement.
- d. The initial step in collecting conducted emission data is a spectrum analyzer peak detector mode pre-scanning the measurement frequency range. Significant peaks are then marked and then Quasi Peak detector mode re-measured.
- e. If the Peak Mode measured value compliance with and lower than Quasi Peak Mode Limit, the EUT shall be deemed to meet QP Limits and then no additional QP Mode measurement performed.
- f. For the actual test configuration, please refer to the related Item –EUT Test Photos.

5.2.Measurement Equipment Used:

EQUIPMENT TYPE	MFR	MODEL NUMBER	SERIAL NUMBER	LAST CAL.	CAL DUE.
Spectrum Analyzer	Rohde & Schwarz	ESU	1302.6005.26	05/29/2013	05/28/2014
EMI Test Receiver	Rohde & Schwarz	ESU	1302.6005.26	05/29/2013	05/28/2014
Pre-Amplifier	HP	8447D	2944A07999	05/29/2013	05/28/2014
Bilog Antenna	Schwarzbeck	VULB9163	142	05/29/2013	05/28/2014
Loop Antenna	ARA	PLA-1030/B	1029	05/29/2013	05/28/2014
Horn Antenna	Schwarzbeck	BBHA 9170	BBHA9170399	05/29/2013	05/28/2014
Horn Antenna	Schwarzbeck	BBHA 9120	D143	05/29/2013	05/28/2014

5.3.Test SET-UP

(a) Radiated Emission Test Set-Up, Frequency Below 30MHz

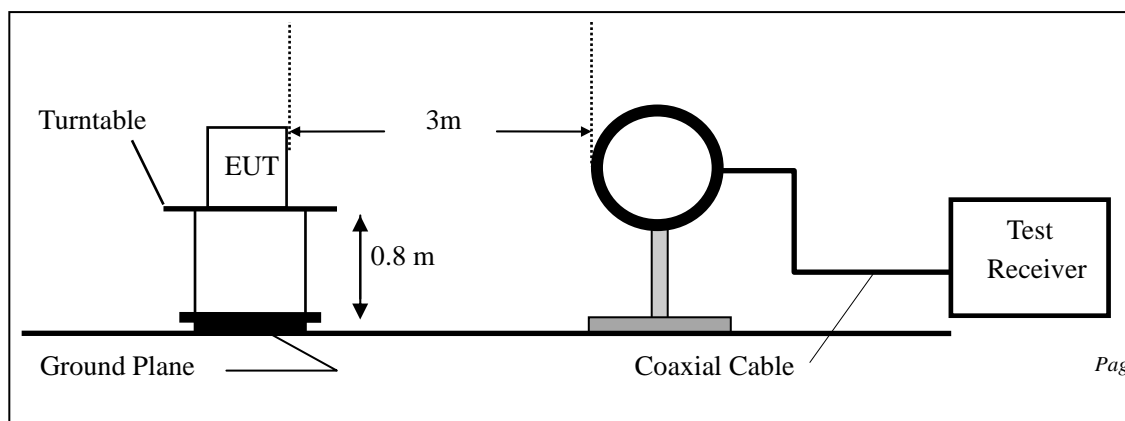

(b) Radiated Emission Test Set-Up, Frequency Below 1000MHz

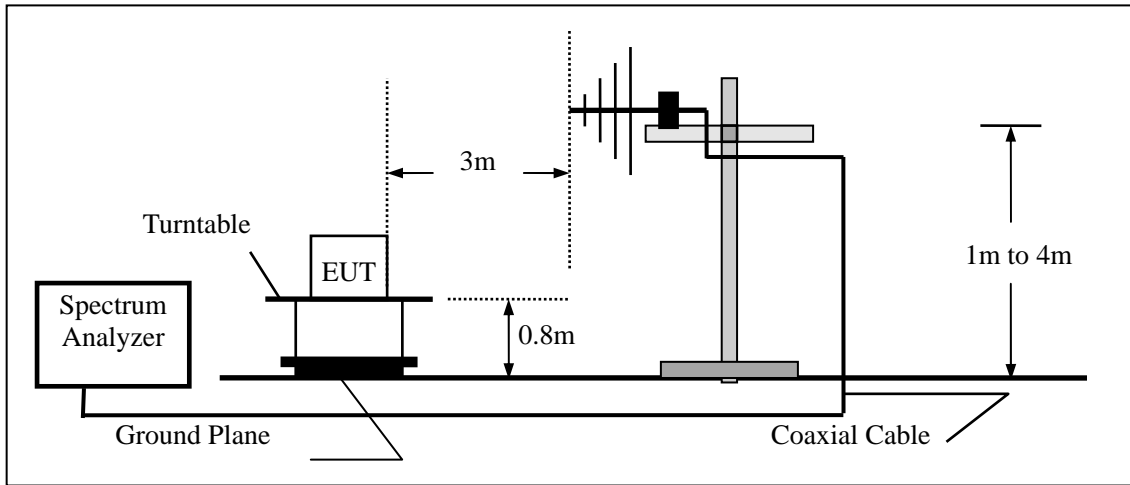

(c) Radiated Emission Test Set-Up, Frequency Above 1000MHz

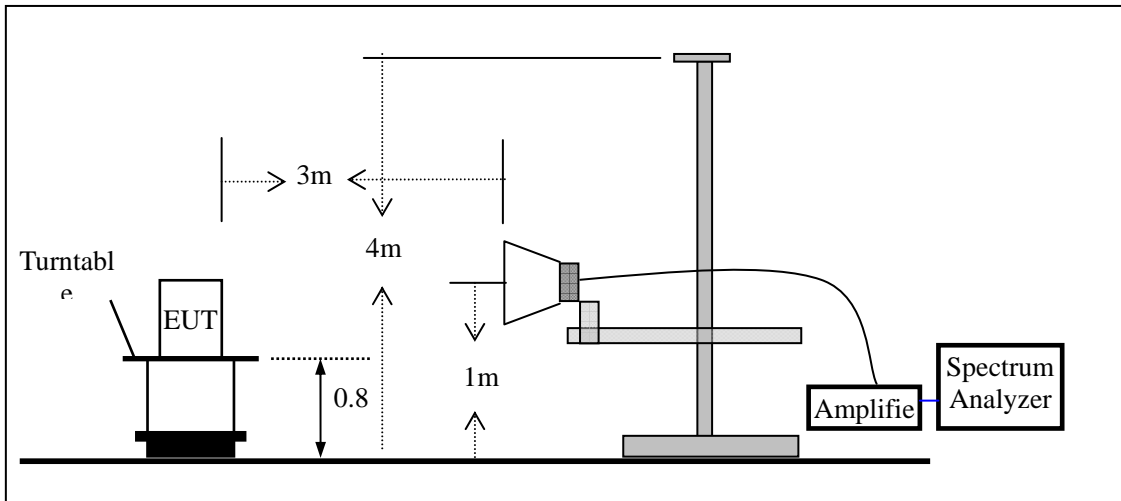

5.4.Radiated Measurement Result

Operation Mode:	Mode 1	Test Date :	May 24, 2013
Frequency Range:	30~1000MHz	Temperature :	22 °C
Test Result:	PASS	Humidity :	55 %
Measured Distance:	3m	Test By:	Rujianbo

Freq. (MHz)	Ant.Pol. H/V	Emission Level (dBuV)	Limit 3m (dBuV/m)	Margin (dB)	Note
33.3280	V	22.6	40.0	-17.4	PK
48.6720	V	20.9	40.0	-19.1	PK
94.428	V	16.0	43.5	-27.5	PK
132.8450	V	17.6	43.5	-25.9	PK
311.954	V	18.0	46.0	-28.0	PK
363.999	V	20.8	46.0	-25.2	PK
260.004	H	19.4	46.0	-26.6	PK
311.999	H	23.9	46.0	-22.1	PK
364.019	H	28.4	46.0	-17.6	PK
/	/	/	/	/	/

- Note:** (1) All Readings are Peak Value.
 (2) Emission Level= Reading Level+Probe Factor +Cable Loss
 (3) The average measurement was not performed when the peak measured data under the limit of average detection.

Operation Mode:	Mode 3	Test Date :	May 24, 2013
Frequency Range:	30~1000MHz	Temperature :	22 °C
Test Result:	PASS	Humidity :	55 %
Measured Distance:	3m	Test By:	Rujianbo

Freq. (MHz)	Ant.Pol. H/V	Emission Level (dBuV)	Limit 3m (dBuV/m)	Margin (dB)	Note
33.328	V	23.8	40.0	-16.2	PK
43.812	V	18.5	40.0	-21.5	PK
52.760	V	18.3	40.0	-21.7	PK
100.580	V	18.3	43.5	-25.2	PK
132.685	V	17.1	43.5	-26.4	PK
363.999	V	16.7	46.0	-29.3	PK
31.070	H	20.3	40.0	-19.8	PK
32.519	H	20.5	40.0	-19.5	PK
155.910	H	14.5	43.5	-29.0	PK
260.144	H	19.0	46.0	-27.0	PK
312.179	H	24.0	46.0	-22.0	PK
364.259	H	25.8	46.0	-20.2	PK

- Note:** (1) All Readings are Peak Value.
 (2) Emission Level= Reading Level+Probe Factor +Cable Loss
 (3) The average measurement was not performed when the peak measured data under the limit of average detection.

Operation Mode:	Mode 2	Test Date :	May 24, 2013
Frequency Range:	30~1000MHz	Temperature :	22 °C
Test Result:	PASS	Humidity :	55 %
Measured Distance:	3m	Test By:	Rujianbo

Freq. (MHz)	Ant.Pol. H/V	Emission Level (dBuV)	Limit 3m (dBuV/m)	Margin (dB)	Note
33.211	V	23.1	40.0	-16.9	PK
50.586	V	19.8	40.0	-20.2	PK
59.025	V	16.7	40.0	-23.3	PK
74.919	V	15.2	40.0	-24.8	PK
100.580	V	16.4	43.5	-27.2	PK
133.151	V	13.5	43.5	-30.0	PK
364.259	V	22.3	46.0	-23.7	PK
32.634	H	18.5	40.0	-21.5	PK
100.580	H	17.2	43.5	-26.3	PK
155.910	H	13.4	43.5	-30.1	PK
260.144	H	20.0	46.0	-26.0	PK
312.179	H	24.6	46.0	-21.5	PK
364.259	H	26.3	46.0	-19.7	PK

- Note:** (1) All Readings are Peak Value.
 (2) Emission Level= Reading Level+Probe Factor +Cable Loss
 (3) The average measurement was not performed when the peak measured data under the limit of average detection.

Operation Mode: Mode 1 Test Date : May 24, 2013
 Frequency Range: 1000-25000MHz Temperature : 22 °C
 Test Result: PASS Humidity : 55 %
 Measured Distance: 3m Test By: Rujianbo

Freq. (MHz)	Ant.Pol .	Emission Level (dBUV)		Limit 3m (dBUV/m)		Margin(dB)	
		H/V	PK	AV	PK	AV	PK
2406.999	V	77.5	64.5	114.0	94.0	-36.5	-29.5
4813.998	V	52.2	34.1	74.0	54.0	-21.8	-19.9
7220.997	V	51.4	33.6	74.0	54.0	-22.6	-20.4
7892.628	V	47.2	30.1	74.0	54.0	-26.8	-23.9
--	--						
2406.999	H	74.2	60.8	114.0	94.0	-39.9	-33.2
4813.998	H	51.5	34.6	74.0	54.0	-22.5	-19.5
7220.997	H	56.6	39.7	74.0	54.0	-17.4	-14.3
--	--	--	--	--	--	--	--

- Note:** (1) All Readings are Peak Value and AV.
 (2) Emission Level= Reading Level+Probe Factor +Cable Loss
 (3) The average measurement was not performed when the peak measured data under the limit of average detection.
 (4)Data of measurement within this frequency range shown “ --” in the table above means the reading of emissions are attenuated more than 20dB below the permissible limits or the field strength is too small to be measured

Operation Mode: Mode 2 Test Date : May 24, 2013
 Frequency Range: 1000-25000MHz Temperature : 22 °C
 Test Result: PASS Humidity : 55 %
 Measured Distance: 3m Test By: Rujianbo

Freq. (MHz)	Ant.Pol .	Emission Level (dBuV)		Limit 3m (dBuV/m)		Margin(dB)	
		H/V	PK	AV	PK	AV	PK
2431.792	V	78.6	65.4	114.0	94.0	-35.4	-28.6
4863.584	V	51.9	33.3	74.0	54.0	-22.1	-20.7
7295.376	V	51.4	33.9	74.0	54.0	-22.6	-20.1
--	--	--	--	--	--	--	--
2431.792	H	73.7	60.1	114.0	94.0	-40.3	-33.9
4863.584	H	51.2	33.9	74.0	54.0	-22.8	-20.1
7295.376	H	54.3	37.3	74.0	54.0	-19.7	-16.7
--	--	--	--	--	--	--	--

- Note:** (1) All Readings are Peak Value and AV.
 (2) Emission Level= Reading Level+Probe Factor +Cable Loss
 (3) The average measurement was not performed when the peak measured data under the limit of average detection.
 (4)Data of measurement within this frequency range shown “ --” in the table above means the reading of emissions are attenuated more than 20dB below the permissible limits or the field strength is too small to be measured

Operation Mode: Mode 3 Test Date : May 24, 2013
 Frequency Range: 1000-25000MHz Temperature : 22 °C
 Test Result: PASS Humidity : 55 %
 Measured Distance: 3m Test By: Rujianbo

Freq. (MHz)	Ant.Pol .	Emission Level (dBUV)		Limit 3m (dBUV/m)		Margin(dB)	
		H/V	PK	AV	PK	AV	PK
2457.386	V	81.3	67.8	114.0	94.0	-32.7	-26.2
4914.772	V	50.0	32.5	74.0	54.0	-24.0	-21.5
7372.158	V	51.8	34.1	74.0	54.0	-22.2	-19.9
--	--	--	--	--	--		
2457.386	H	72.8	59.4	114.0	94.0	-41.2	-34.6
4914.772	H	51.0	33.2	74.0	54.0	-23.0	-20.8
7372.158	H	52.0	34.9	74.0	54.0	-22.0	-19.1
--	--	--	--	--	--	--	--

- Note:** (1) All Readings are Peak Value and AV.
 (2) Emission Level= Reading Level+Probe Factor +Cable Loss
 (3) The average measurement was not performed when the peak measured data under the limit of average detection.
 (4)Data of measurement within this frequency range shown “ --” in the table above means the reading of emissions are attenuated more than 20dB below the permissible limits or the field strength is too small to be measured

5.5.Radiated Measurement Photos:

30M~100MHz:

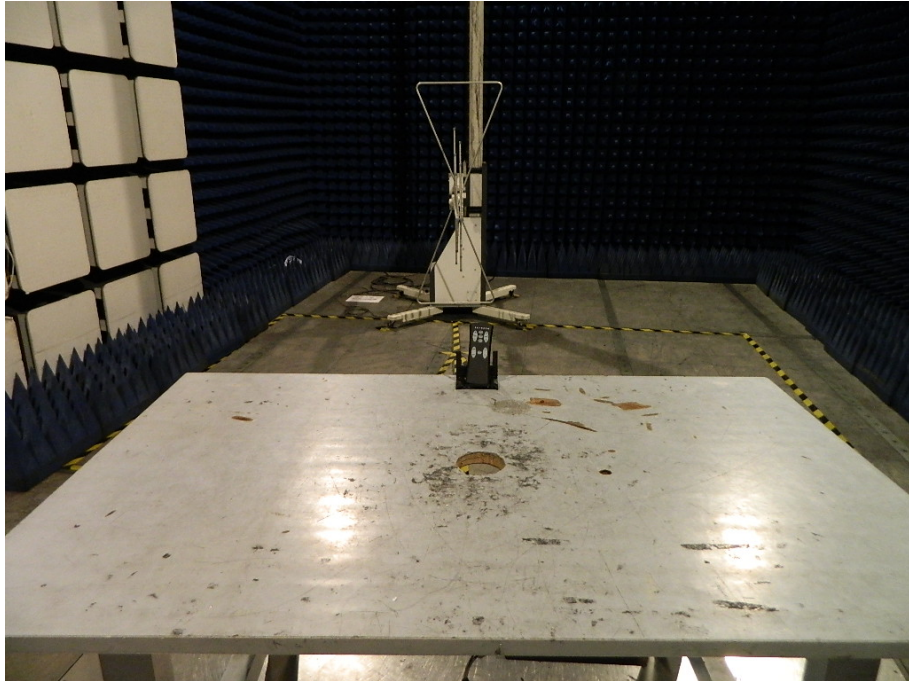

Above 1000MHz:

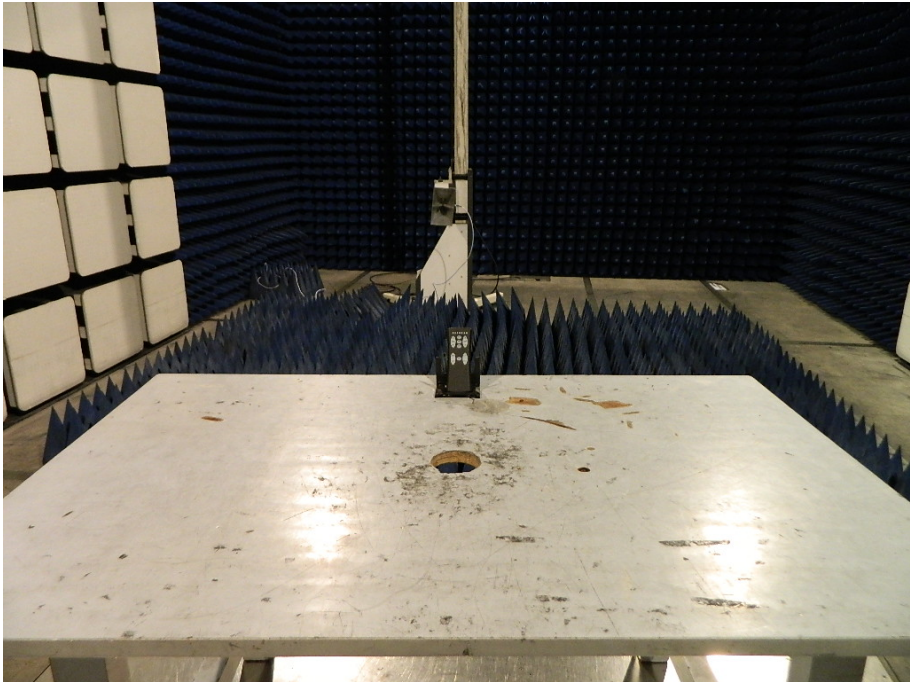

6. BAND EDGES MEASUREMENT

6.1. Standard Applicable

According to 15.249(d), out band emission except for harmonics shall be comply with §15.209 or at least attenuated by 50 dB below the level of the fundamental.

6.2. Measurement Procedure

- a. The EUT was directly connected to the spectrum analyzer and antenna output port as show in the block diagram below.
- b. Spectrum Setting : RBW= 100KHz, VBW=100KHz, Sweep time = AUTO.

6.3. Measurement Equipment

EQUIPMENT TYPE	MFR	MODEL NUMBER	SERIAL NUMBER	LAST CAL.	CAL DUE.
Spectrum Analyzer	Rohde & Schwarz	ESU	1302.6005.26	05/29/2013	05/28/2014
EMI Test Receiver	Rohde & Schwarz	ESU	1302.6005.26	05/29/2013	05/28/2014
Pre-Amplifier	HP	8447D	2944A07999	05/29/2013	05/28/2014
Bilog Antenna	Schwarzbeck	VULB9163	142	05/29/2013	05/28/2014
Loop Antenna	ARA	PLA-1030/B	1029	05/29/2013	05/28/2014
Horn Antenna	Schwarzbeck	BBHA 9170	BBHA9170399	05/29/2013	05/28/2014
Horn Antenna	Schwarzbeck	BBHA 9120	D143	05/29/2013	05/28/2014

6.4. Test Setup

Same as 5.3 Radiated Emission Measurement.

6.5. Test Results

Pass

The test plots as following:

Lower band edge (Peak)

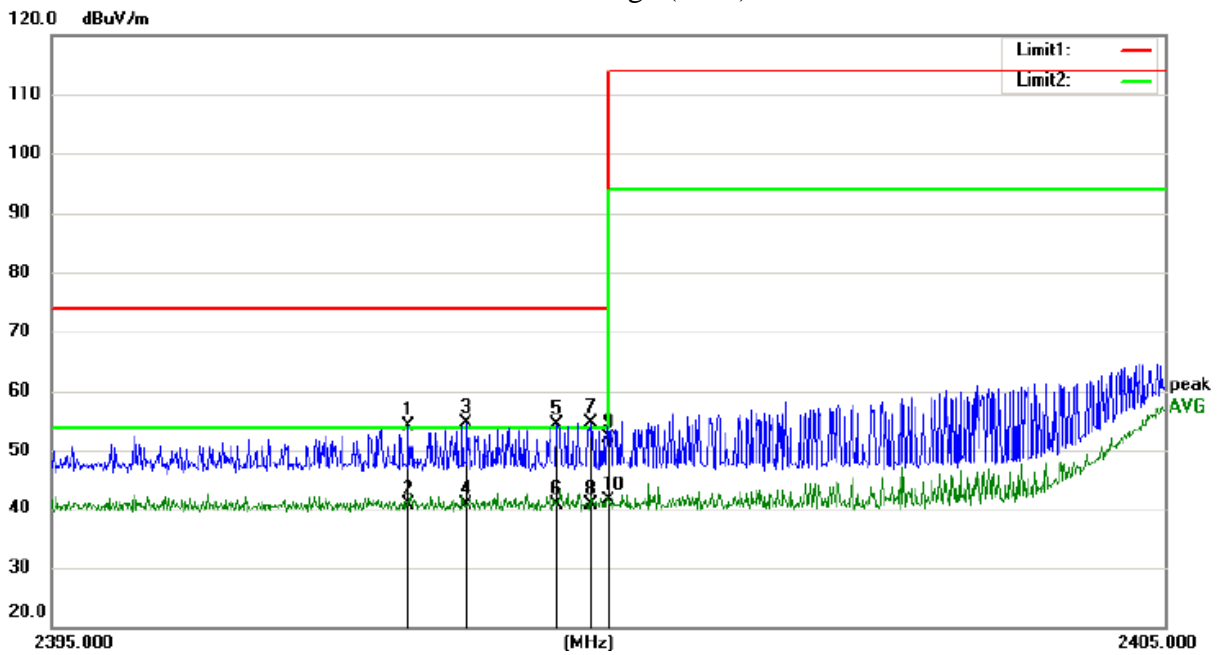

No.	Mk.	Freq. MHz	Reading Level dBuV	Correct Factor dB	Measure- ment dBuV/m	Limit dBuV/m	Over dB	Detector	Antenna Height cm	Table Degree degree	Comment
1		2398.210	42.86	11.31	54.17	73.90	-19.73	peak			
2		2398.210	29.21	11.31	40.52	53.90	-13.38	AVG			
3		2398.730	43.23	11.32	54.55	73.90	-19.35	peak			
4		2398.730	29.19	11.32	40.51	53.90	-13.39	AVG			
5		2399.540	42.93	11.33	54.26	73.90	-19.64	peak			
6		2399.540	29.41	11.33	40.74	53.90	-13.16	AVG			
7		2399.840	43.39	11.33	54.72	73.90	-19.18	peak			
8		2399.840	29.30	11.33	40.63	53.90	-13.27	AVG			
9		2400.000	40.69	11.33	52.02	73.90	-21.88	peak			
10	*	2400.000	29.93	11.33	41.26	53.90	-12.64	AVG			

Upper band edge (Peak)

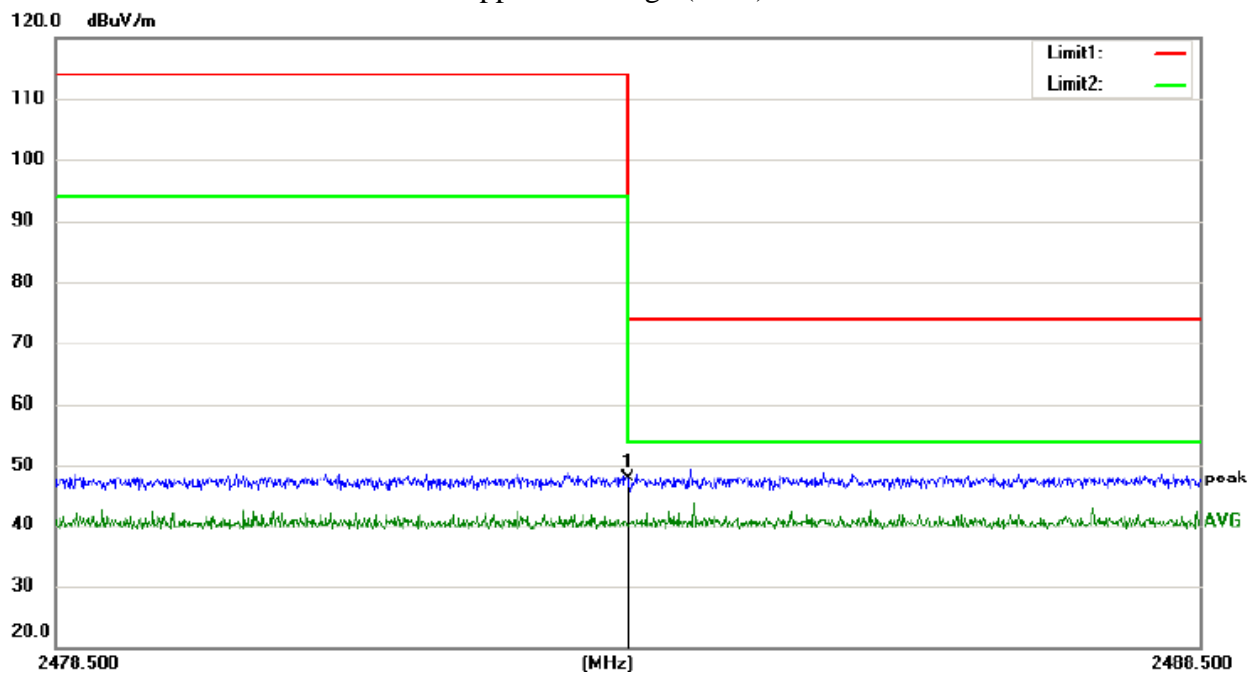

No.	Mk.	Freq.	Reading Level	Correct Factor	Measurement	Limit	Over	Antenna Height	Table Degree	
		MHz	dBuV	dB	dBuV/m	dBuV/m	dB	cm	degree	Comment
1	*	2483.500	35.78	12.13	47.91	73.90	-25.99			peak

7. ANTENNA APPLICATION

7.1. Standard Applicable

According to §15.203, an intentional radiator shall be designed to ensure that no antenna other than that furnished by the responsible party shall be used with the device.

7.2. Antenna Construction

The EUT'S antenna (PCB antenna) is permanently integrated on the main EUT, no consideration of replacement.