



SRMANM (CC2533 ZigBee MODULE) USER GUIDE





Contents

1	Introduction	4
1.1	Purpose and scope	4
1.2	Revision History	4
2	Module Application Circuit	5
2.1	Sample Application Connections	5
2.2	Compliance Limits	6
2.3	Module Power Supply	6
3	Antenna Options and PCB Footprint.....	7
3.1	Footprint Overview	7
3.2	Module Footprint	8
4	Agency Statements	9
4.1	Federal Communication Commission Interference Statement	9
4.2	ETSI (European Telecommunications Standards Institute) Statement.....	9
4.3	RF Exposure	9
4.4	End Product Labelling.....	10
5	Contact Detail.....	11



Figures

Figure 1: SRMANM Application Circuit	5
Figure 2: Header Board Footprint Overview.....	7
Figure 3: SRMANM Module Footprint overview	8

Tables

Table 1: Compliance Limit.....	6
--------------------------------	---



1 Introduction

1.1 Purpose and scope

The purpose of this document is to provide details regarding the use of CC2533 ZigBee Module (SRMANM). This document describes the connections between CC2533 Module and header board. This connection details can be used to mount Module on other Host Board.

1.2 Revision History

Date	Change Description	Revision
25DEC2013	Initial release	1.0

2 Module Application Circuit

2.1 Sample Application Connections

Figure 1 shows the circuit connection between SRMANM Module and CC2533 Header board. Header board provide the power supply to the SRMANM Module and also debug header for programming the CC2533.

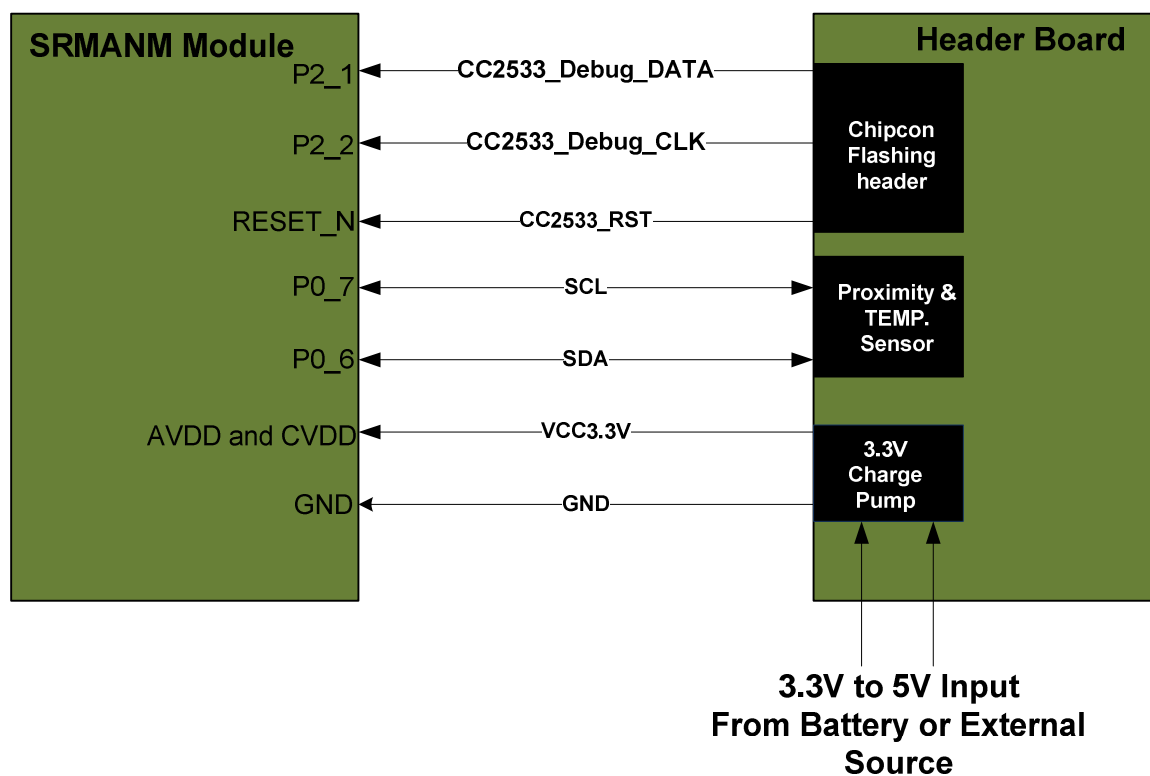

Figure 1: SRMANM Application Circuit

Please refer SRMANM datasheet for module pin description. Based on application requirements host device can be interfaced with other pins on the module. Please refer TI-CC2533 user guide for connection/state information of unused pins.



2.2 Compliance Limits

Depending on the country where the module is used, proper power level needs to be set to meet compliance limit to ensure the certification of module.

Table 1 shows the register value configuration for RF Power to meet compliance limit for ETSI standard.

Table 1: Compliance Limit

Compliance	TX POWER Register value
ETSI	0XF5

Note: *The register value used for FCC compliance is maximum value and cannot be increased by end user. The RF Output Power configuration is not accessible to End User.*

2.3 Module Power Supply

The SRMANM Module can operate between 2.7V to 3.6V power level. However, it is recommended to provide nominal 3.3VDC supply to Module VCC and GND pins. For details of VCC – GND pins; please refer Module datasheet.

3 Antenna Options and PCB Footprint

SRMANM (CC2533 Module) has PCB Inverted F Antenna designed on Board.

3.1 Footprint Overview

Below figure shows the footprint detail of the Header board for SRMANM Module. The Header Board (or Host Board) Footprint will be designed as per the Module footprint as mentioned in datasheet.

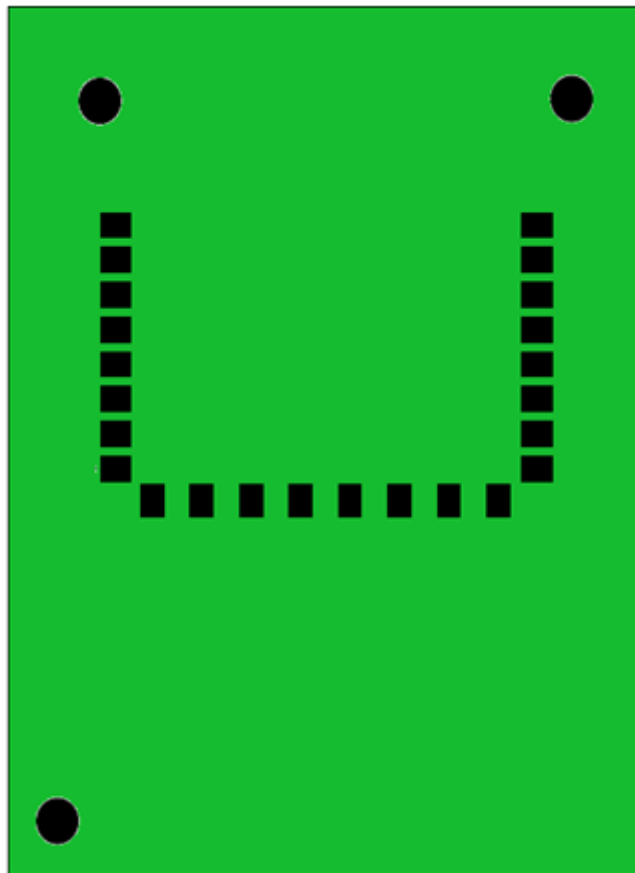

Figure 2: Header Board Footprint Overview

3.2 Module Footprint

Figure 3 shows the Module footprint over the Header board

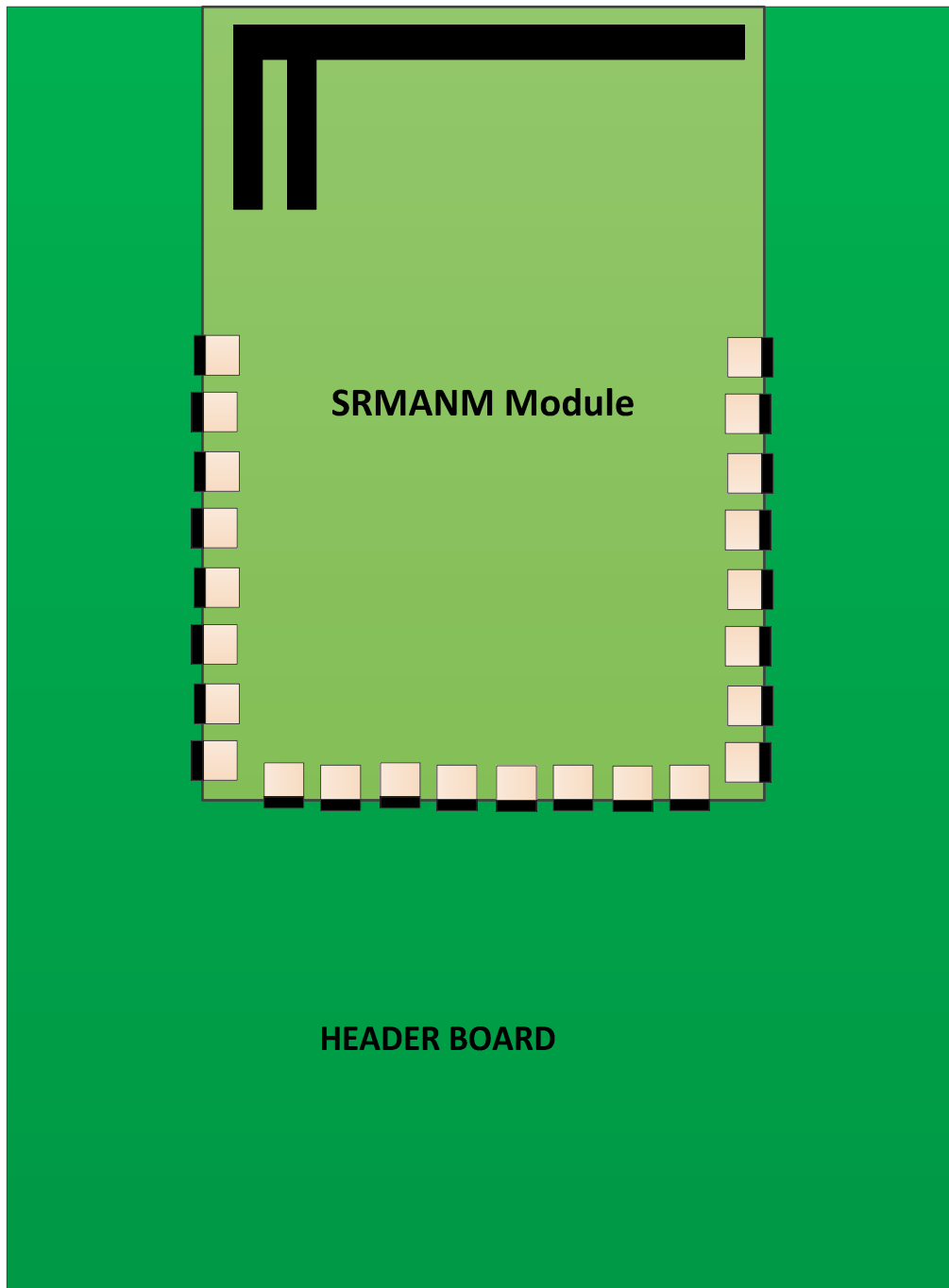

Figure 3: SRMANM Module Footprint overview



4 Agency Statements

4.1 Federal Communication Commission Interference Statement

This equipment has been tested and found to comply with the limits for a Class B digital device, pursuant to Part 15 of the FCC Rules. These limits are designed to provide reasonable protection against harmful interference in a residential installation. This equipment generates; uses and can radiate radio frequency energy and, if not installed and used in accordance with the instructions, may cause harmful interference to radio communications. However, there is no guarantee that interference will not occur in a particular installation. If this equipment does cause harmful interference to radio or television reception, which can be determined by turning the equipment off and on, the user is encouraged to try to correct the interference by one of the following measures:

- Reorient or relocate the receiving antenna.
- Increase the separation between the equipment and receiver.
- Connect the equipment into an outlet on a circuit different from that to which the receiver is connected.
- Consult the dealer or an experienced radio/TV technician for help.

This device complies with Part 15 of the FCC Rules. Operation is subject to the following two conditions: (1) This device may not cause harmful interference, and (2) this device must accept any interference received, including interference that may cause undesired operation.

FCC Caution: Any changes or modifications not expressly approved by the party responsible for compliance could void the user's authority to operate this equipment.

4.2 ETSI (European Telecommunications Standards Institute) Statement

This device has been tested and certified for use in the European Union. If this device is used in a product, the OEM has responsibility to verify compliance of the final product to the EU standards.

4.3 RF Exposure

This module has been certified for remote and base radio applications and is not intended to be operated within 20 cm of the body. If the module will be used for portable applications, the device must undergo SAR testing.



Following instruction can be included in Final product user manual.

Instruction: To satisfy FCC RF exposure requirements for mobile transmitting devices, a separation distance of 20 cm or more should be maintained between the antenna of this device and persons during operation. To ensure compliance, operations at closer distances than this are not recommended.”

4.4 End Product Labelling

The SRMANM Module is labelled with its own FCC ID. If the FCC ID Certification Number is not visible while installed inside another device, then the device should display the label on it referring the enclosed module. In that case, the final end product must be labelled in a visible area with the following:

“Contains Transmitter Module FCC ID: PBR-SZMDLMA1”

OR

“Contains FCC ID: PBR-SZMDLMA1”

The OEM should not provide information to the end user regarding installation or removal of this RF module or change RF related parameters in the user manual of the end product.

The OEM integrator is still responsible for testing their end-product for any additional compliance requirements required with this module installed (for example, digital device emissions, PC peripheral requirements, etc.).



5 Contact Detail

The Kroger Co.

11450 Groom Road

Blue Ash, OH-45242,

USA