



SREXGM3 MODULE (CC2538-CC2592 ZigBee Module) USER GUIDE





Contents

1	Introduction	4
1.1	Purpose and scope	4
1.2	Revision History	4
2	Module Application Circuit.....	5
2.1	Sample Application Connections	5
2.2	Compliance Limits	6
2.3	Module Power Supply	6
3	Antenna Options and PCB Footprint	7
3.1	Footprint Overview	7
3.2	Module Footprint.....	8
4	FCC Compliance Statements	9
4.1	End Product Labelling.....	10
5	Contact Detail.....	10



Figures

Figure 1: SREXRGM3 Module Application Circuit.....	5
Figure 2: Header Board Footprint Overview	7
Figure 3: SREXRGM3 Module Footprint Overview.....	8

Tables

No table of figures entries found.



1 Introduction

1.1 Purpose and scope

The purpose of this document is to provide details regarding the use of SREXRG3 Module. This document describes the connections between SREXRG3 Module and header board. This connection details can be used to mount Module on other Host Board.

1.2 Revision History

Date	Change Description	Revision
19MAR2018	Initial release	0.1
22MAR2018	Sent to Kroger for Review	0.2
23MAR2018	Sent to TUV for Review	0.3

2 Module Application Circuit

2.1 Sample Application Connections

Figure 1 shows the circuit connection between SREXRG3 Module and Debug board. Debug board provide the power supply to the SREXRG3 Module and has debug header for programming the CC2538 chip.

Below is the connection diagram of SREXRG3 module and header board.

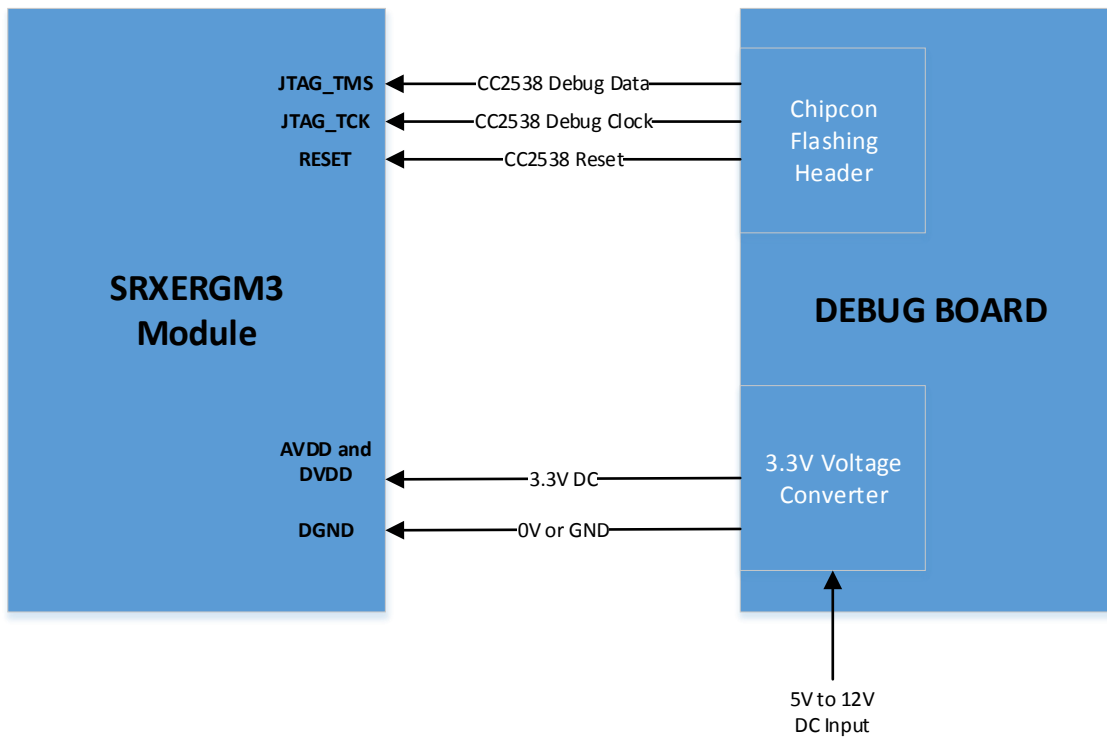

Figure 1: SREXRG3 Module Application Circuit

Please refer SREXRG3 datasheet for module pin description. Based on application requirements, host device can be interfaced with other pins on the module. Please refer TI-CC2538 user guide for connection/state information of unused pins.



2.2 Compliance Limits

The register value used for FCC compliance is maximum value and cannot be increased by end user. The RF Output Power configuration is not accessible to End User.

2.3 Module Power Supply

The SREXGM3 Module can operate between 2.7V to 3.6V power level. However, it is recommended to provide nominal 3.3VDC supply to Module VCC and GND pins. For details of VCC – GND pins; please refer Module datasheet.

3 Antenna Options and PCB Footprint

3.1 Footprint Overview

Below figure shows the footprint detail of the SREXGM3 Header board.



Figure 2: Header Board Footprint Overview

3.2 Module Footprint

Figure 3 shows the Module footprint over the Header board

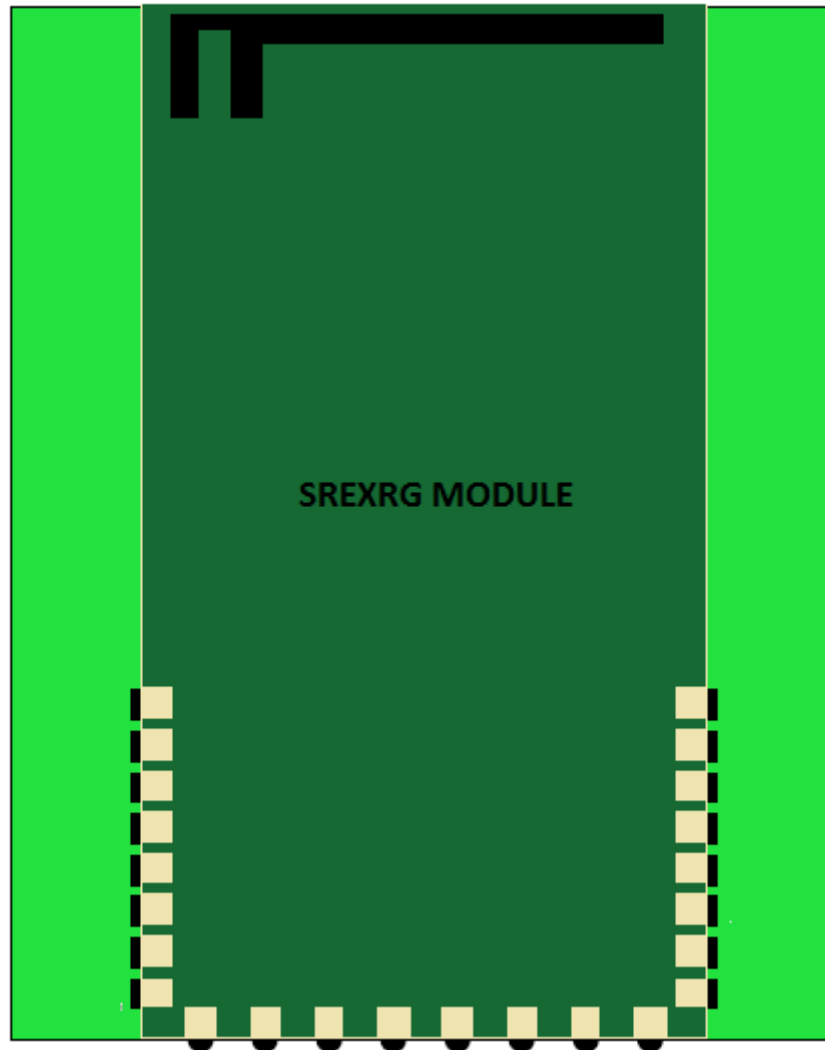

Figure 3: SREXRGM3 Module Footprint Overview



4 FCC Compliance Statements

FCC ID: PBR-SZMDLM3BR1

FCC Compliance Statements

1. This device may not cause harmful interference, and
2. This device must accept any interference received, including Interference that may cause undesired operation.

FCC Caution!!!

- Any changes or modifications not expressly approved by the party responsible for compliance could void the user's authority to operate this equipment.
- This equipment should be installed and operated with minimum distance 20 cm between the radiator & your body.

Part 15B compliance statements for digital devices:

Note: This equipment has been tested and found to comply with the limits for a Class B digital device, pursuant to Part 15 of the FCC Rules. These limits are designed to provide reasonable protection against harmful interference in a residential installation. This equipment generates; uses and can radiate radio frequency energy and, if not installed and used in accordance with the instructions, may cause harmful interference to radio communications. However, there is no guarantee that interference will not occur in a particular installation. If this equipment does cause harmful interference to radio or television reception, which can be determined by turning the equipment off and on, the user is encouraged to try to correct the interference by one of the following measures:

- Reorient or relocate the receiving antenna.
- Increase the separation between the equipment and receiver.
- Connect the equipment into an outlet on a circuit different from that to which the receiver is connected.
- Consult the dealer or an experienced radio/TV technician for help.



Following instruction can be included in Final product user manual.

Instruction: To satisfy FCC RF exposure requirements for mobile transmitting devices, a separation distance of 20 cm or more should be maintained between the antenna of this device and persons during operation. To ensure compliance, operations at closer distances than this are not recommended.”

4.1 End Product Labelling

The SREXGM3 Module is labelled with its own FCC ID Number. If the FCC ID Certification Number is not visible while installed inside another device, then the device should display the label on it referring to the enclosed module. In that case, the final end product must be labelled in a visible area with the following:

“Contains Transmitter Module FCC ID: PBR-SZMDLM3BR1”

OR

“Contains FCC ID: PBR-SZMDLM3BR1”

The OEM should not provide information to the end user regarding installation or removal of this RF module or change RF related parameters in the user manual of the end product.

The OEM integrator is still responsible for testing their end-product for any additional compliance requirements required with this module installed (for example, digital device emissions, PC peripheral requirements, etc.).

5 Contact Detail

The Kroger Co.

11450 Groom Road

Blue Ash, OH-45242,

USA