

MEASUREMENT REPORT of *Wireless LAN Access Point*

Applicant : TeLLUS Group Corporation
Applicant address : 5F, No. 24-2, Industrial E Rd. IV,
Science-Based Industrial Park, Hsinchu, Taiwan
EUT : Wireless LAN Access Point
Model : A14
FCC ID : PB6-02102
Report No. : T6915550

Tested by :

Training Research Co., Ltd.

TEL : 886-2-26935155 FAX : 886-2-26934440

No. 255, Nanyang Street, Shijr, Taipei Hsien 221, Taiwan, R.O.C.

CERTIFICATION

We here by verify that:

The test data, data evaluation, test procedures and equipment configurations shown in this report were made mainly in accordance with the procedures given in ANSI C63.4 (1992) as a reference. All test were conducted by *Training Research Co., Ltd.*, 255 Nanyang Street, Shijr, Taipei Hsien 221, Taiwan, R.O.C. Also, we attest to the accuracy of each.

We further submit that the energy emitted by the sample EUT tested as described in the report is **in compliance with** the technical requirements set forth in the FCC Rules Part 15 Subpart B (Declaration of Conformity) and C Section 15.247.

Product Name : Wireless LAN Access Point
Model Name : A14
FCC ID : PB6-02102
Report No. : T6915550
Test Date : April 11, 2003

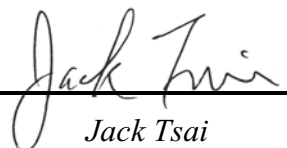
Prepared by: 
Jack Tsai

Approved by: 
Frank Tsai

Conditions of issue :

- (1) **This test report shall not be reproduced except in full, without written approval of TRC. And the test result contained within this report only relate to the sample submitted for testing.**
- (2) **This report must not be used by the client to claim product endorsement by NVLAP or any agency of U.S. Government.**

★ NVLAP LAB CODE: 200174-0

Federal Communications Commission **Declaration of Conformity (DoC)**

For the Following Equipment:

Product name : **Wireless LAN Access Point**
Model name : **A14**
Trade name : **TeLLUS**

Is herewith confirmed and found to comply with the requirements of CFR 47 part15 Subpart B - Unintentional Radiators regulation. The results of electromagnetic mission evaluation are shown in the report number : T6915550

This device complies with Part 15 of the FCC Rules. Operation is subject to the following two conditions:

- (1) This device may not cause harmful interference, and
- (2) This device must accept any interference received, including interference that may cause undesired operation

<i>Manufacturer</i>	<i>USA local representative</i>
Company name: TeLLUS Group Corporation	To be determined
Computer address: 5F, No 24-2, Industrial E. Rd. IV, Science-Based Industrial Park, Hsinchu, Taiwan	
ZIP / Postal code 300	
Contact person: Elvan Yang	
Title: R&D Manager	
Internet e-mail address: elvan@tellus.com.tw	
Tel / Fax: 886-2-5780275 / 886-2-5780279	

Tables of Contents

Declaration of Conformity (DoC)	3
I. GENERAL	6
1.1 Introduction	6
1.2 Description of EUT	6
1.3 Test method	6
1.4 Description of Support Equipment	7
1.5 Configuration of System Under Test	9
1.6 Verify the Frequency and Channel	11
1.7 Test Procedure	12
1.8 Location of the Test Site	12
1.9 General Test Condition	12
II. Section 15.101(a) : Equipment Authorization of Unintentional Radiators	13
III. Section 15.203 : Antenna Requirement	14
IV. Section 15.207 : Power Line Conducted Emissions for AC Powered Units	15
4.1 Test Condition & Setup	15
4.2 List of Test Instruments	15
4.3 Test Result of Conducted Emissions	16
Table 1 Conducted emissions of Channel 01	16
Table 2 Conducted emissions of Channel 06	17
Table 3 Conducted emissions of Channel 11	17
Table 4 Conducted emissions of Standby mode	18
V. Section 15.247(a) : Technical Description of the EUT	19
VI. Section 15.247(a)(2) : Bandwidth for Direct Sequence System	20
6.1 Test Condition & Setup	20
6.2 Test Instruments Configuration	20
6.3 List of Test Instruments	20
6.4 Test Result of Bandwidth	21
Channel 01	22
Channel 06	23
Channel 11	24

VII. Section 15.247(b) : Power Output 25

 7.1 Test Condition & Setup 25

 7.2 List of Test Instruments 25

 7.3 Test Result 26

VIII. Section 15.247(c) : Spurious Emissions (Radiated) 27

 8.1 Test Condition & Setup 27

 8.2 List of Test Instruments 28

 8.3 Test Result of Spurious Radiated Emissions 29

 Table 5 Radiated emissions of Horizontal for 30MHz to 1GHz 29

 Table 6 Radiated emissions of Vertical for 30MHz to 1GHz 29

 Table 7 Above 1GHz radiated emissions of Horizontal of CH1 30

 Table 8 Above 1GHz radiated emissions of Vertical of CH1 30

 Table 9 Above 1GHz radiated emissions of Horizontal of CH6 31

 Table 10 Above 1GHz radiated emissions of Vertical of CH6 31

 Table 11 Above 1GHz radiated emissions of Horizontal of CH11 32

 Table 12 Above 1GHz radiated emissions of Vertical of CH11 32

 8.4 Test Result of Bandedge..... 33

 Channel 01 34

 Channel 11 35

IX. Section 15.247(d) : Power Spectral Density 36

 9.1 Test Condition & Setup 36

 9.2 Test Instruments Configuration 36

 9.3 List of Test Instruments 36

 9.4 Test Result of Power Spectral Density 37

 Channel 01 38

 Channel 06 39

 Channel 11 40

I . GENERAL

1.1 Introduction

The following measurement report is submitted on behalf of applicant in support that the certification in accordance with Part 2 Subpart J and Part 15 Subpart A, B and C of the Commission's Rules and Regulations.

1.2 Description of EUT

Granted FCC ID	:	PB6-02102
Product Name	:	Wireless LAN Access Point
Model Name	:	A14
Frequency Range	:	2.412 GHz ~ 2.462GHz
Support Channel	:	11 Channel
Modulation Skill	:	DBPSK, DQPSK, CCK
Power Type	:	By the Power Adaptor Mfg.: Touch Electronic Co., Ltd. ; M/N: SA070507 I/P: 100-240Vac, 50-60Hz; 0.4A ; O/P: 5Vdc, 10W
Power Cable	:	180cm long, non-shielded, no ferrite core
Data Cable	:	RJ45 cable, 30m, non-shielded, no ferrite core USB cable, 1.85m, shielded, no ferrite core

1.3 Test method

1. Using the LAN port of far-end computer and software provided by the manufacturer to control the EUT. The test is performed under those specific conditions.
2. Set different channel being tested and repeat the procedures above.
 - (a) Radiated for intentional test:
making EUT to the mode of continuous transmission
 - (b) Conducted and Radiated for unintentional test:
making EUT to the linking (Rx/Tx) mode with far support equipments

1.4 Description of Support Equipment

In order to construct the minimum testing, following equipment were used as the support units.

Notebook : **IBM Think Pad X20**
 Type No. : 2662-11T
 Serial No. : FX-11922 00/09
 FCC ID : Doc Approved
 檢磁 : 3892B565

AC Adaptor : **IBM**
 Model No. : PA2450U
 Serial No. : 02K6654
 FCC ID : Doc Approved
 Power Core : Non-shielded, 180cm long, Plastic hoods, with ferrite bead
 Power type : 100 ~ 240VAC, 50 ~ 60Hz, 0.5A ~ 1.2A / 16Vdc, 4.5A

Mouse : **HP**
 Model No. : M-UR89
 Serial No. : LZS21750238
 FCC ID : Doc Approved
 檢磁 : 3892D767
 Power type : By PC
 Power cord : Shielded, 1.80m length, No ferrite core

Fax/Modem : **Aceex**
 Model No. : DM-1414
 Serial No. : 9010582
 FCC ID : IFAXDM1414
 Power type : 110 VAC / 50 ~ 60 Hz, Switching
 Power Cord : Non-shielded, 1.90m long, Plastic hoods, and no ferrite bead
 Data Cable : RS-232→Shielded, 1.30m long, Metal hoods , No bead
 RJ-11Cx2→Non-shielded, 7' long, Plastic hoods, No bead

HUB : **D-Link**
 Model No. : DGS-1008T
 FCC ID : N/A, DoC Approved
 Power type : I/P: 100 ~ 240vac, 50 ~ 60 Hz, 0.7A
 Power cord : Non-shielded, no ferrite core, 1.90m long

Printer : **HP**
Model No. : C6464A
Serial No. : TH16LEB5PK
FCC ID : N/A, DoC Approved
檢磁 : 3892H381
Power type : Switching adaptor
Power cord : Non-shielded, 173cm long, No ferrite core
(between adaptor and AC source)
Non-shielded, 180cm long, with ferrite core
(between printer and adaptor)
Data cable : Shielded, 1.70m long, No ferrite core
USB Gamepad : **Rockfire**
Model No. : QF-337uv
Serial No. : 10600545, KR91379759
FCC ID : None (CE approval)
檢磁 : 3862A574
Power type : By computer
Data Cable : Shielded, 1.81m long, Plastic, with ferrite core
Notebook : **ASUSTek Computer**
Model No. : AB00F
Serial No. : 24NP016370
FCC ID : Doc Approved
BSMI : 41016012
Power type : 100 ~ 240VAC, 1A 50/60 Hz, Switching
Power Adaptor : **LITE-ON Electronics, Inc.**
Model No. : PA-1530-01
Serial No. : 00153468
FCC ID : Doc Approved
檢磁 : 3882B259
Power cable : Non-shielded, 1.72m length, Plastic hood, No ferrite core
(Between power adaptor to and AC power source)
Power cable : Shielded, 1.48m length, Plastic hood, with ferrite core
(Between power adaptor and notebook)

1.5 Configuration of System Under Test

(Conducted and Radiated for unintentional)

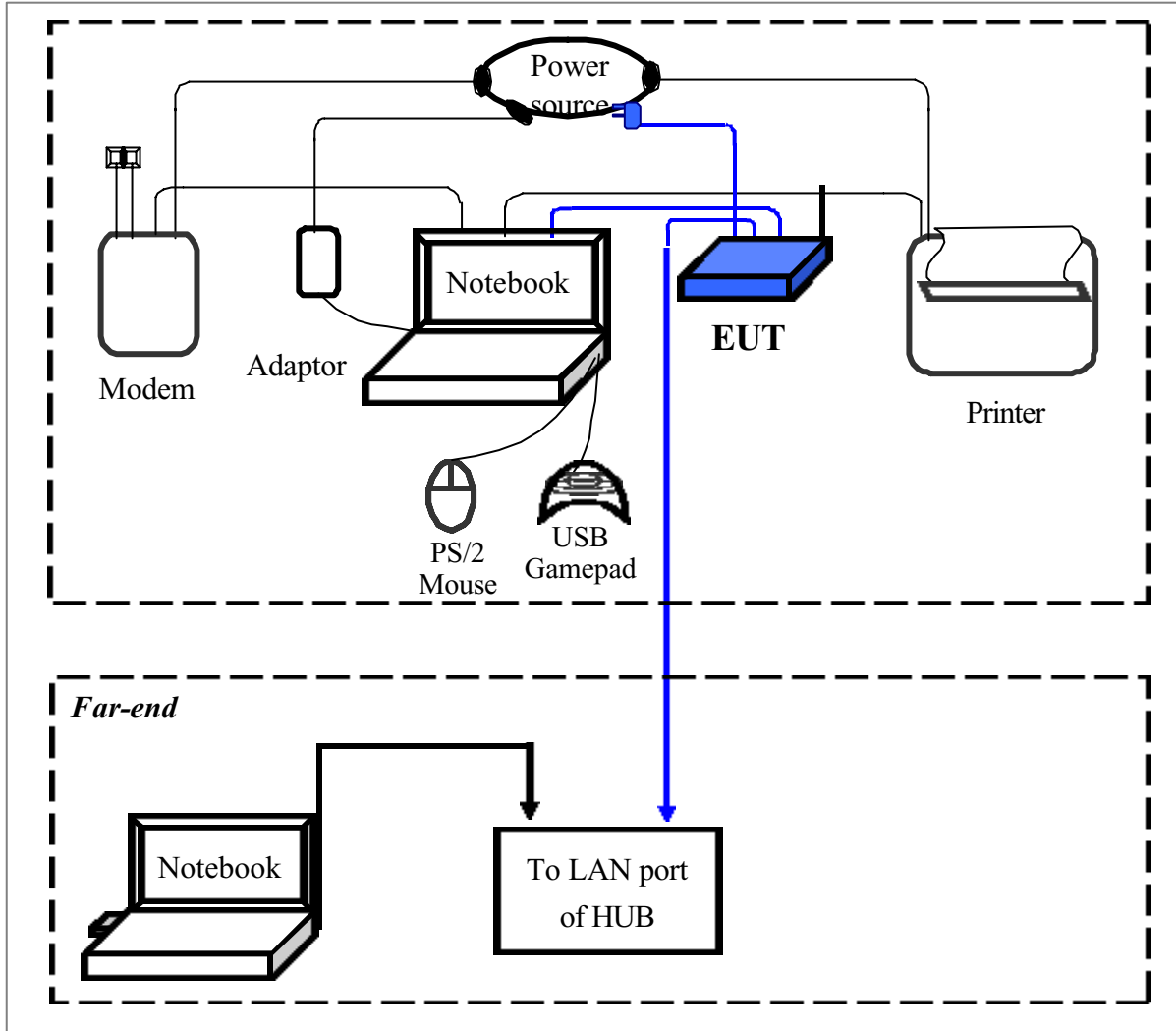

Connections of Equipment

- Adaptor :** *Power cable --- 180cm long, non-shielded, no ferrite core
- WLAN AP :** *USB cable *1 --- 185cm long, shielded, no ferrite core
*RJ45 cable *1 --- 30m long, non-shielded, no ferrite core
- Notebook PC:** *Parallel Port --- a printer
*Serial Port --- an external modem
*PS/2 Port --- a PS/2 keyboard
*USB-A Port --- a USB gamepad
*USB-B Port --- EUT

(Radiated of intentional)

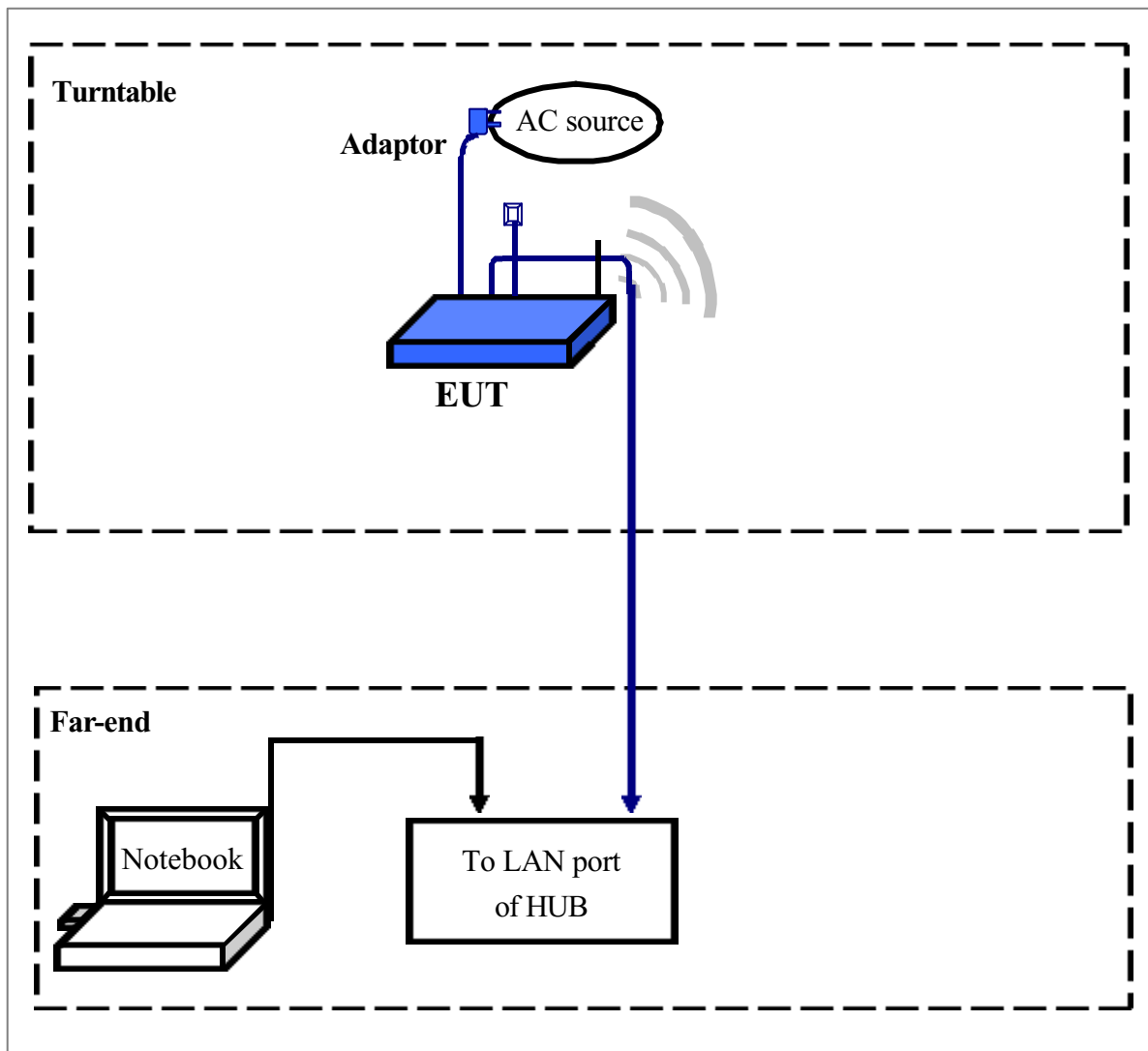

The tests below are carried out the EUT transmitter set at high power in TDD mode. The EUT is needed to force selection of output power level and channel number.

The setting up procedure was recorded in <1.3> test method.

1.6 Verify the Frequency and Channel

Channel	Frequency (GHz)
1	2.412
2	2.417
3	2.422
4	2.427
5	2.432
6	2.437
7	2.442
8	2.447
9	2.452
10	2.457
11	2.462

Note:

1. This is for confirming that all frequencies are in 2.412GHz to 2.462GHz.
2. Section 15.31(m): Measurements on intentional radiators or receivers shall be performed at three frequencies for operating frequency range over 10 MHz.
(The locations of these frequencies one near the top, one near the middle and one near the bottom.)
3. After test, the EUT operating frequencies are in 2.412GHz to 2.462GHz. So all the items as followed in testing report are need to test these three frequencies:
Top: Channel – 1; Middle: Channel – 6; Bottom: Channel – 11.

1.7 Test Procedure

All measurements contained in this report were performed mainly according to the techniques described in ANSI C63.4 (1992) and the pre-setup was written on 1.3 test method, the detail setup was written on each test item.

1.8 Location of the Test Site

The radiated emissions measurements required by the rules were performed on the **three-meter, Anechoic Chamber (Registration Number: 93906)** maintained by *Training Research Co., Ltd.* 1F, No. 255 Nanyang Street, Shijr, Taipei Hsien 221, Taiwan, R.O.C. Complete description and measurement data have been placed on file with the commission. The conducted power line emissions tests and other test items were performed in a anechoic chamber also located at Training Research Co., Ltd.

No. 255 Nanyang Street, Shijr, Taipei Hsien 221, Taiwan, R.O.C. *Training Research Co., Ltd.* is listed by the FCC as a facility available to do measurement work for others on a contract basis.

1.9 General Test Condition

The conditions under which the EUT operates were varied to determine their effect on the equipment's emission characteristics. The final configuration of the test system and the mode of operation used during these tests were chosen as that which produced the highest emission levels. However, only those conditions, which the EUT was considered likely to encounter in normal use were investigated.

In test, they were set in high power and continuously transmitting mode that controlled by computer. The ch01, ch06 and ch11 of EUT were all tested. The setting up procedure is recorded on 1.3 test method.

II. Section 15.101(a): Equipment authorization of unintentional radiators

The EUT equipped with a Universal Serial Bus and should be operated with the computer. It was categorized to *Class B personal computers and peripherals* as cannot be operated stand-alone. The authorization requires **Declaration of Conformity (DoC)** and the items required such as Sect.15.107 (Conducted limits) and Sect.15.109 (Radiated emission limits) is same as Sect.15.207 and 15.247(C).

III. Section 15.203: Antenna requirement

The EUT can be equipped with one detachable antenna. **The detachable antenna is affixed to the EUT using a unique connector, which allows for replacement of a broken antenna, but does not use a standard antenna jack or electrical connector.**

The custom antenna specification of list as below:

Manufacturer	:	Antenniques Corp. Ltd.
Model No.	:	WR-R-AD0008-A1
Part No	:	MCS-003-134-01
Connector	:	SMA Plug Reverse
Antenna Type	:	Dipole Antenna
Antenna Gain	:	2 dBi (Max.)

IV. Section 15.207: Power Line Conducted Emissions for AC Powered Units

4.1 Test Condition & Setup

The power line conducted emission measurements were performed in an anechoic chamber. The EUT was assembled on a wooden table, which is 80 centimeters high, was placed 40 centimeters from the backwall and at least 1 meter from the sidewall.

Power was fed to the EUT from the public utility power grid through a line filter and Line Impedance Stabilization Networks (LISNs). The LISN housing, measuring instrumentation case, ground plane, etc., were electrically bonded together at the same RF potential. The Spectrum analyzer (or EMI receiver) was connected to the AC line through an isolation transformer. The 50-ohm output of the LISN was connected to the spectrum analyzer directly. Conducted emission levels were in the CISPER quasi-peak detection mode. The analyzer's 6 dB bandwidth was set to 9 KHz. No post-detector video filter was used.

The spectrum was scanned from 150 KHz to 30 MHz. The physical arrangement of the test system and associated cabling was varied (within the scope of arrangements likely to be encountered in actual use) to determine the effect on the unit's emanations in amplitude and frequency. All spurious emission frequencies were observed. The highest emission amplitudes relative to the appropriate limit were measured and have been recorded in paragraph 2.4.

There is a test condition applies in this test item, the test procedure description as the following:
EUT transmit only:

The setting up procedure is recorded on <1.3>. Three channels were tested, one in the top (CH01), one in the middle (CH06) and the other in bottom (CH11).

4.2 List of Test Instruments

<u>Instrument Name</u>	<u>Model No.</u>	<u>Brand</u>	<u>Serial No.</u>	<u>Calibration Date</u>	
				<u>Last time</u>	<u>Next time</u>
EMI Receiver	8546A	H P	3520A00242	06/28/02	06/28/03
RF Filter Section	85460A	H P	3448A00217	06/28/02	06/28/03
LISN (EUT)	LISN-01	TRC	9912-03,04	06/04/02	06/04/03
LISN (Support E.)	LISN-01	TRC	9912-05	07/15/02	07/15/03
Auto Switch Box (< 30MHz)	ASB-01	TRC	9904-01	11/20/02	11/20/03

The level of confidence of 95%, the uncertainty of measurement of conducted emission is ± 2.02 dB.

4.3 Test Result of Conducted Emissions

EUT station transmit only

The following table shows a summary of the highest emissions of power line conducted emissions on the LIVE and NETURAL conductors of the EUT power cord.

Test Conditions: Testing room : Temperature : 22.3 °C Humidity : 61.8 % RH

Table 1 Test mode: Channel 1

<i>Power Connected Emissions</i>					<i>FCC Class B</i>		
<i>Conductor</i>	<i>Frequency (KHz)</i>	<i>Peak (dBµV)</i>	<i>QP (dBµV)</i>	<i>Average (dBµV)</i>	<i>QP-limit (dBµV)</i>	<i>AVG-limit (dBµV)</i>	<i>Margin (dB)</i>
Line 1	206.00	50.10	---	---	64.40	54.40	-4.30
	409.00	40.93	---	---	61.89	51.89	-10.96
	587.00	38.53	---	---	58.60	48.60	-10.07
	681.00	36.81	---	---	56.00	46.00	-9.19
	1464.00	35.74	---	---	56.00	46.00	-10.26
	13673.75	47.10	44.82	34.51	60.00	50.00	-15.18
Line 2	205.00	49.75	---	---	64.43	54.43	-4.68
	405.00	40.88	---	---	58.71	48.71	-7.83
	587.00	39.11	---	---	56.00	46.00	-6.89
	681.00	38.67	---	---	56.00	46.00	-7.33
	1854.00	38.42	---	---	56.00	46.00	-7.58
	13667.36	50.04	48.49	41.01	60.00	50.00	-8.99

NOTE:

- (1)Margin = Amplitude – Limit, **The reading amplitudes are all under limit.**
- (2)A "+" sign in the margin column means the emission is OVER the Class B Limit and "-" sign of means UNDER the Class B limit

Table 2 Test mode: Channel 6

<i>Power Connected Emissions</i>					<i>FCC Class B</i>		
<i>Conductor</i>	<i>Frequency (KHz)</i>	<i>Peak (dBμV)</i>	<i>QP (dBμV)</i>	<i>Average (dBμV)</i>	<i>QP-limit (dBμV)</i>	<i>AVG-limit (dBμV)</i>	<i>Margin (dB)</i>
Line 1	206.00	49.30	---	---	64.40	54.40	-5.10
	409.00	41.59	---	---	58.60	48.60	-7.01
	587.00	38.93	---	---	56.00	46.00	-7.07
	2846.00	37.29	---	---	56.00	46.00	-8.71
	4905.00	38.58	---	---	56.00	46.00	-7.42
	13710.00	46.14	---	---	60.00	50.00	-3.86
Line 2	195.00	49.98	---	---	64.71	54.71	-4.73
	409.00	40.85	---	---	58.60	48.60	-7.75
	681.00	38.37	---	---	56.00	46.00	-7.63
	1854.00	38.42	---	---	56.00	46.00	-7.58
	4406.00	38.74	---	---	56.00	46.00	-7.26
	13607.50	51.11	40.18	42.07	60.00	50.00	-7.93

Table 3 Test mode: Channel 11

<i>Power Connected Emissions</i>					<i>FCC Class B</i>		
<i>Conductor</i>	<i>Frequency (KHz)</i>	<i>Peak (dBμV)</i>	<i>QP (dBμV)</i>	<i>Average (dBμV)</i>	<i>QP-limit (dBμV)</i>	<i>AVG-limit (dBμV)</i>	<i>Margin (dB)</i>
Line 1	205.00	48.46	---	---	64.43	54.43	-5.97
	405.00	41.68	---	---	58.71	48.71	-7.03
	581.00	38.55	---	---	56.00	46.00	-7.45
	2437.00	36.62	---	---	56.00	46.00	-9.38
	5050.00	38.15	---	---	60.00	50.00	-11.85
	13850.00	45.20	---	---	60.00	50.00	-4.80
Line 2	205.00	49.21	---	---	64.43	54.43	-5.22
	409.00	41.73	---	---	58.60	48.60	-6.87
	587.00	39.23	---	---	56.00	46.00	-6.77
	1070.00	37.77	---	---	56.00	46.00	-8.23
	4367.00	38.19	---	---	56.00	46.00	-7.81
	13647.00	47.82	48.63	41.82	60.00	50.00	-8.18

Table 4 Test mode: Standby

<i>Power Connected Emissions</i>					<i>FCC Class B</i>		
<i>Conductor</i>	<i>Frequency (KHz)</i>	<i>Peak (dBμV)</i>	<i>QP (dBμV)</i>	<i>Average (dBμV)</i>	<i>QP-limit (dBμV)</i>	<i>AVG-limit (dBμV)</i>	<i>Margin (dB)</i>
Line 1	205.00	47.82	---	---	64.43	54.43	-6.61
	405.00	41.21	---	---	58.71	48.71	-7.50
	681.00	33.96	---	---	56.00	46.00	-12.04
	876.00	35.60	---	---	56.00	46.00	-10.40
	1359.00	34.45	---	---	56.00	46.00	-11.55
	1941.00	35.86	---	---	56.00	46.00	-10.14
	3221.00	35.02	---	---	56.00	46.00	-10.98
	4857.00	37.06	---	---	56.00	46.00	-8.94
	5940.00	38.53	---	---	60.00	50.00	-11.47
	13990.00	42.58	---	---	60.00	50.00	-7.42
Line 2	203.00	49.60	---	---	64.49	54.49	-4.89
	405.00	41.59	---	---	58.71	48.71	-7.12
	485.00	39.39	---	---	56.43	46.43	-7.04
	876.00	38.65	---	---	56.00	46.00	-7.35
	1359.00	38.15	---	---	56.00	46.00	-7.85
	1941.00	37.49	---	---	56.00	46.00	-8.51
	2532.00	37.49	---	---	56.00	46.00	-8.51
	3780.00	37.77	---	---	56.00	46.00	-8.23
	5540.00	38.69	---	---	60.00	50.00	-11.31
	13641.00	47.29	---	---	60.00	50.00	-2.71

V. Section 15.247 (a): Technical description of the EUT

Based on the Section 2.1, *Direct Sequence System* is a spread spectrum system in which the carrier has been modulated by a high speed spreading code and an information data stream. The high speed code sequence dominates the “modulating function” and is the direct cause of the wide spreading of the transmitted signal. In the Exhibit, operational description demonstrates the operation principles of the Baseband processor employed by the EUT, shows that which is a complete DSSS baseband processor and meets the definition of the direct sequence spread spectrum system.

VI. Section 15.247(a)(2): Bandwidth for Direct Sequence System.

6.1 Test Condition & Setup

The transmitter bandwidth measurements were performed by the contact manner. The EUT was set to transmit continuously, also various channels were investigated to find the maximum occupied bandwidth. The output of the EUT was connected to the spectrum analyzer. The bandwidth of the fundamental frequency is observed by the spectrum analyzer with 100kHz RBW and 100kHz VBW.

6.2 Test Instruments Configuration

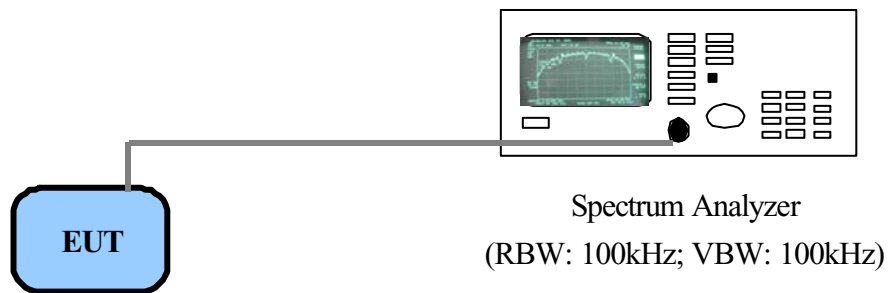

Test Configuration of Bandwidth for Direct Sequence System

P.S.: Notebook computer to control the EUT at maximal power output and channel number and set antenna kit

6.3 List of Test Instruments

Instrument Name	Model No.	Brand	Serial No.	Last time	Next time
Spectrum Analyzer	MS2665C	ANRITSU	6200175476	09/11/02	09/11/03

6.4 Test Result of Bandwidth

Bandwidth of Channel 1

Bandwidth : 10.28 MHz
The min. 6 dB BW at least : 500 KHz

Bandwidth of Channel 6

Bandwidth : 10.16 MHz
The min. 6 dB BW at least : 500 KHz

Bandwidth of Channel 11

Bandwidth : 10.32 MHz
The min. 6 dB BW at least : 500 KHz

Note:

1. The data in the above table are summarizing the following attachment spectrum analyzer hard copy. According to the guidance, we'd made the measurement with the spectrum analyzer's resolution bandwidth (RBW)=100kHz and set the $span \gg RBW$. The results show the measured 6dB bandwidth comply with the minimum 500kHz requirement.
2. The attachments show these on the following pages.

Bandwidth of Channel 1: 10.28 MHz

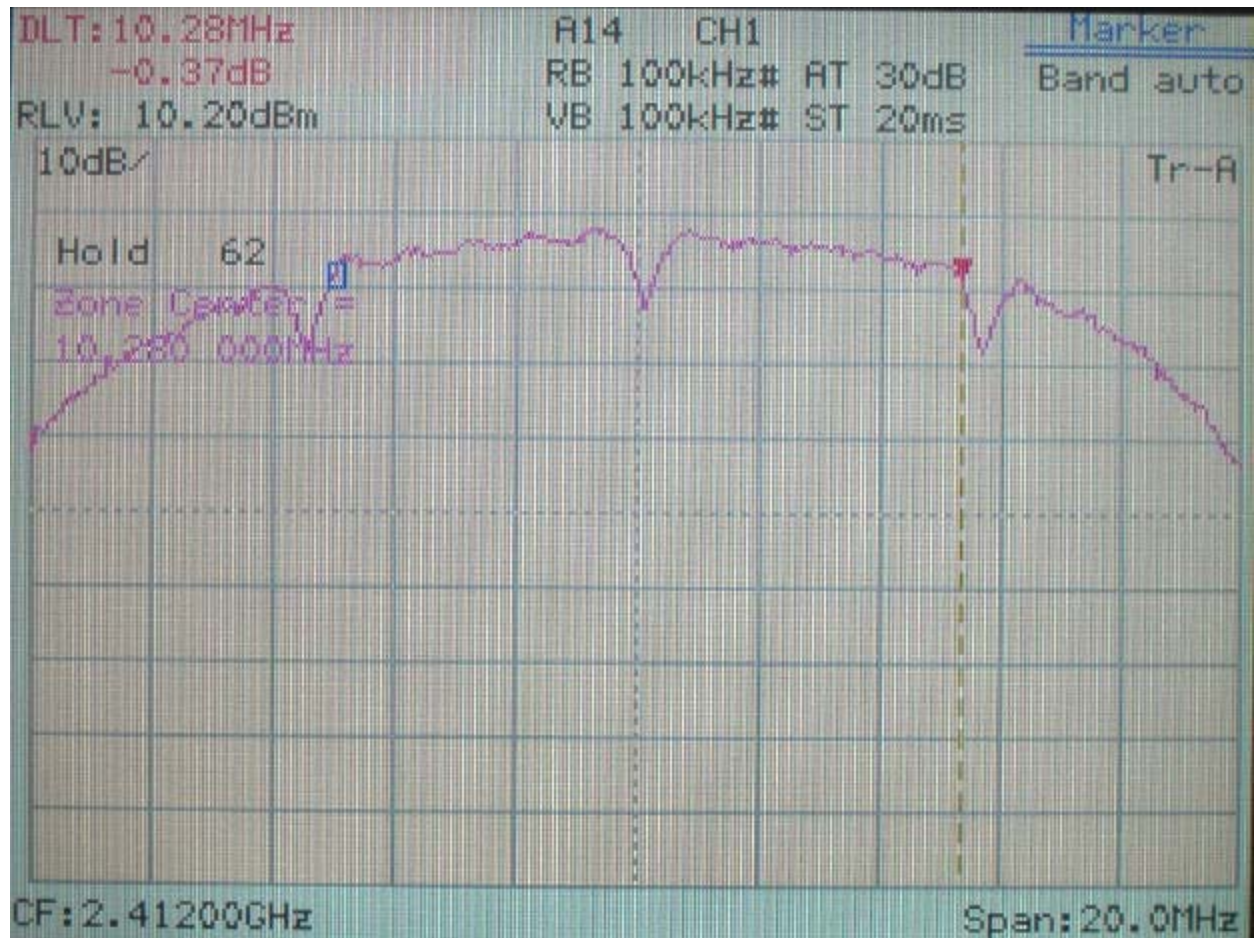

Bandwidth of Channel 6: 10.16 MHz



Bandwidth of Channel 11: 10.32 MHz

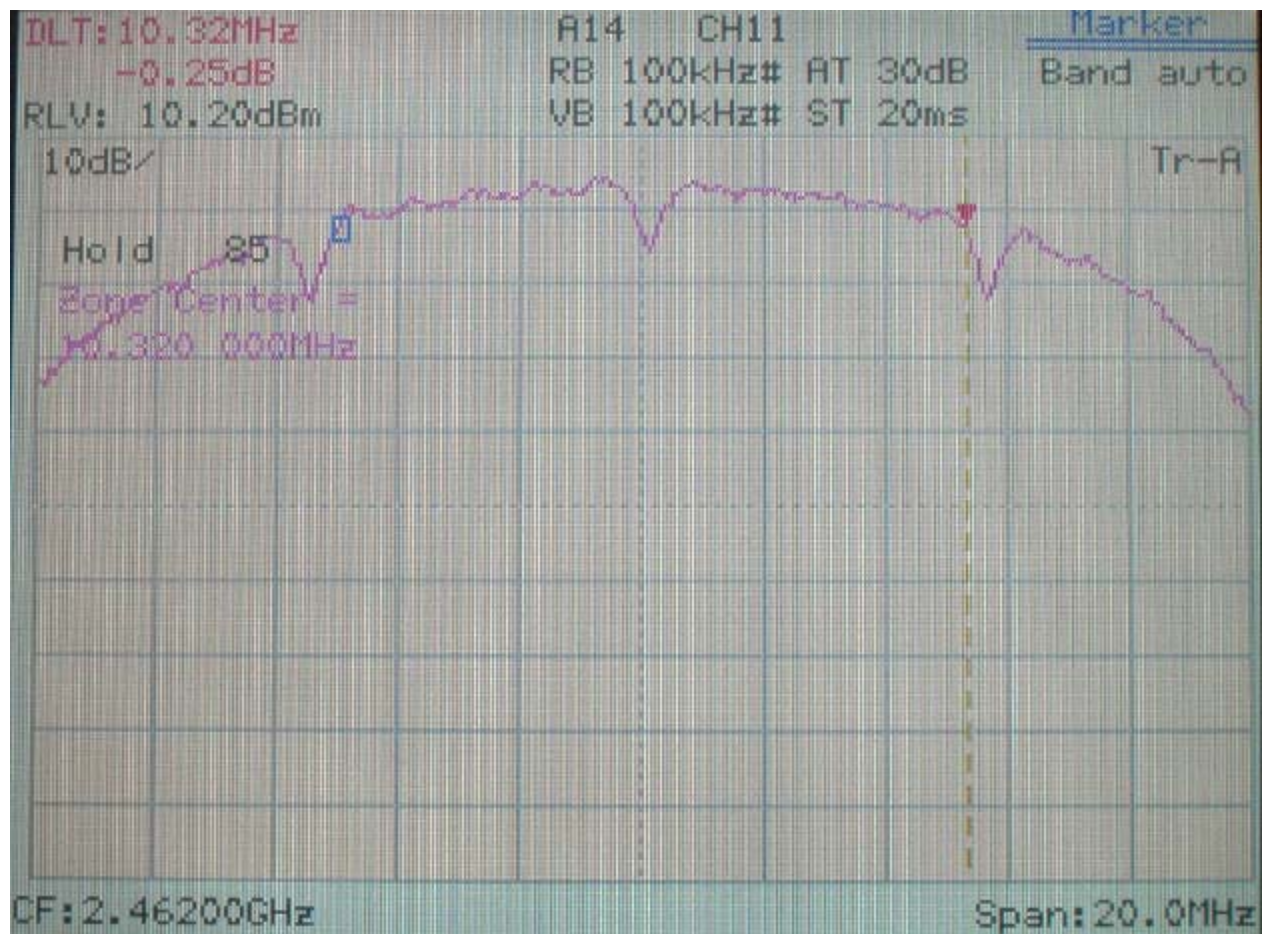

VII. Section 15.247(b): Power Output

7.1 Test Condition & Setup

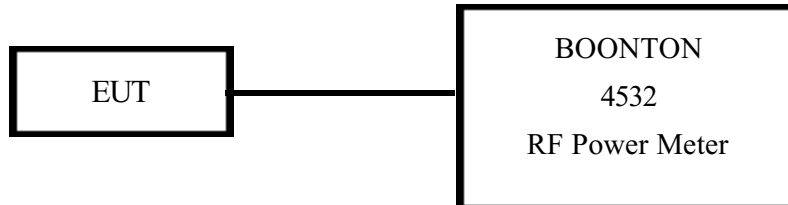

1. The output of the transmitter is connected to the BOONTON RF Power Meter.
2. The calibration is performed before every tests. The values of the output power of the EUT will shown in the dBm directly are the transmitter output peak power. Recording as follows.

7.2 List of Test Instruments

Instrument Name	Model No.	Brand	Serial No.
RF Power Meter	4532	BOONTON	117501

7.3 Test Result

Formula: Signal generator + | Cable loss | = Output peak power

Channel	Signal Generator	Cable Loss	Output peak power	
	dBm	dBm	dBm	mW
CH 1	19.89	0.5	20.39	109.396
CH 6	20.22	0.5	20.72	118.032
CH 11	20.27	0.5	20.77	119.399

VIII. Section 15.247 (C): Spurious Emissions (Radiated)

8.1 Test Condition & Setup

We'd performed the test by the *radiated emission* skill: The EUT was placed in an anechoic chamber, and set the EUT transmitting continuously and scanned at 3-meter distance to determine its emission characteristics. The physical arrangement of the EUT was varied (within the scope of arrangements likely to be encountered in actual use) to determine the effect on the unit's emanations in amplitude, directivity, and frequency. The exact system configuration, which produced the highest emissions was noted so it could be reproduced later during the final tests. For the measurement above 1GHz, according to the guidance we'd set the spectrum analyzer's 6dB bandwidth RBW to 1MHz.

This was done to ensure that the final measurements would demonstrate the worst-case interference potential of the EUT. Final radiation measurements were made on a three-meter, anechoic chamber. The EUT system was placed on a nonconductive turntable, which is 0.8 meters height, top surface 1.0 x 1.5 meter.

The spectrum was examined from 30 MHz to 1000 MHz using an Hewlett Packard 85460A EMI Receiver, Schwarzeck whole range Small Biconical antenna (Model No.: BBVU9135) is used to measure frequency from 30 MHz to 1GHz. The final test is used the HP 85460A spectrum and 8564E spectrum was examined from 1GHz to 25GHz using an Hewlett Packard Spectrum Analyzer, EMCO/CMT Horn Antenna (Model 3115 / RA42-K-F-4B-C) for 1G to 25GHz. At each frequency, the EUT was rotated 360 degrees, and the antenna was raised and lowered from one to four meters to find the maximum emission levels. Measurements were taken using both horizontal and vertical antenna polarization.

Appropriate preamplifiers were used for improving sensitivity and precautions were taken to avoid overloading or desensitizing the spectrum analyzer. There are two spectrum analyzers use on this testing, HP 85460A for frequency 30MHz to 1000MHz, and 8564E for frequency 1GHz to 25GHz. No post-detector video filters were used in the test. The spectrum analyzer's 6dB bandwidth was set to 120KHz (spectrum was examined from 30 MHz to 1000 MHz), the spectrum analyzer's 6dB bandwidth was set to 1 MHz (spectrum was examined from 1GHz to 25GHz) and the analyzer was operated in the maximum hold mode. There is a test condition applies in this test item, the test procedure description as the <1.3> test method:

Three channels were tested, one in the top (CH01), one in the middle (CH06) and the other in bottom (CH11).

With the transmitter operating from a AC source and using the internal of EUT, radiates spurious emissions falling within the restricted bands of 15.209 were measured at operating frequencies corresponding to upper, middle and bottom channels in the 2400 ~ 2483.5 MHz band.

The actual field intensity in decibels referenced to 1 microvolt per meter (dBµV/m) is determined by algebraically adding the measured reading in dBµV, the antenna factor (dB), and cable loss (dB) at the appropriate frequency. Since the EUT was set to transmit continuously, no *duty cycle* is present.

For frequency between 30MHz to 1000MHz

$F_{Ia} \text{ (dB}\mu\text{V/m)} = F_{Ir} \text{ (dB}\mu\text{V)} + \text{Correction Factors}$

F_{Ia} : Actual Field Intensity

F_{Ir} : Reading of the Field Intensity

$\text{Correction Factors} = \text{Antenna Factor} + \text{Cable Loss} - \text{Amplifier Gain}$

For frequency between 1 GHz to 25 GHz

$F_{Ia} \text{ (dB}\mu\text{V/m)} = F_{Ir} \text{ (dB}\mu\text{V)} + \text{Correction Factor}$

F_{Ia} : Actual Field Intensity

F_{Ir} : Reading of the Field Intensity

$\text{Correction Factors} = \text{Antenna Factor} + \text{Cable Loss} - \text{Amplifier Gain}$

8.2 List of Test Instruments

Instrument Name	Model No.	Brand	Serial No.	Last time	Next time
EMI Receiver	8546A	H P	3520A00242	06/28/02	06/28/03
RF Filter Section	85460A	H P	3448A00217	06/28/02	06/28/03
Small Biconical	BBVU9135	Schwarzeck	127	05/07/02	05/07/03
Antenna and Balun	UBAA9114				
Switch/Control Unit (>30MHz)	3488A	HP	N/A	11/20/02	11/20/03
Auto Switch Box (>30MHz)	ASB-01	TRC	9904-01	11/20/02	11/20/03
Spectrum Analyzer	8564E	HP	US36433002	08/01/02	08/01/03
Microwave Preamplifier	83051A	HP	3232A00347	08/01/02	08/01/03
Horn Antenna	3115	EMCO	9704 – 5178	08/01/02	08/01/03
Horn Antenna	RA42-K-F-4B-C	CMT	961505-003	02/01/03	02/01/04
Anechoic Chamber (cable calibrated together)				05/20/02	05/20/03

The level of confidence of 95% , the uncertainty of measurement of radiated emission is ± 3.44dB .

8.3 Test Result of Spurious Radiated Emissions

EUT's transmit only

The highest peak values of radiated emissions from the EUT at various antenna heights, antenna polarizations, EUT orientation, etc. are recorded on the following.

Test Conditions: Testing room : Temperature : 20.3 ° C Humidity : 55.4 % RH

Table 5 Radiated Emissions for 30MHz to 1GHz [Antenna Polarity Horizontal]

Radiated Emission				Correction Factors (dB)	Corrected Amplitude (dBμV/m)	FCC Class B (3 m)	
Frequency (MHz)	Amplitude (dBμV)	Ant. H. (m)	Table (°)			Limit (dBμV/m)	Margin (dB)
91.84	29.86	1.00	131	0.34	30.20	43.50	-13.30
234.91	40.18	1.00	268	-2.80	37.38	46.00	-8.62
300.39	33.72	1.00	43	-2.35	31.37	46.00	-14.63
481.66	27.17	1.00	248	3.90	31.07	46.00	-14.93
721.12	24.90	1.00	244	12.16	37.06	46.00	-8.94
748.00	30.40	1.00	165	12.69	43.09	46.00	-2.91

Table 6 Radiated Emissions For 30MHz to 1GHz [Antenna Polarity Vertical]

Radiated Emission				Correction Factors (dB)	Corrected Amplitude (dBμV/m)	FCC Class B (3 m)	
Frequency (MHz)	Amplitude (dBμV)	Ant. H. (m)	Table (°)			Limit (dBμV/m)	Margin (dB)
32.01	29.39	1.00	277	7.92	37.31	40.00	-2.69
108.00	39.50	1.00	219	-0.78	38.72	43.50	-4.78
159.13	37.20	1.00	188	-2.39	34.81	43.50	-8.69
528.34	28.33	1.00	19	5.87	34.20	46.00	-11.80
665.96	25.73	1.00	322	10.74	36.47	46.00	-9.53
748.00	27.44	1.00	30	12.69	40.13	46.00	-5.87

Note: 1. Margin = Amplitude – limit, if margin is minus means under limit.

2. Corrected Amplitude = Reading Amplitude + Correction Factors

3. Correction factor = Antenna factor + [Cable Loss – Amplitude Gain]

Table 7 Radiated Emissions for 1GHz to 25GHz [Ant. Polarity Horizontal] [CH 1]

Radiated Emission				Corrected Amplitude		FCC Class B (3m)		
Frequency (MHz)	Ant. H. (m)	Table (°)	Correction Factors (dB)	(dBµV/m)		Limit (dBµV/m)		Margin (dB)
				Peak	Average	Peak	Ave.	
4824.33	1.00	98	3.76	49.03	---	74.00	53.96	-4.93
7238.58	1.00	308	10.10	45.87	---	74.00	53.96	-8.09
9648.00	1.00	29	11.46	47.73	---	74.00	53.96	-6.23

Table 8 Radiated Emissions for 1GHz to 25GHz [Ant. Polarity Vertical] [CH 1]

Radiated Emission				Corrected Amplitude		FCC Class B (3m)		
Frequency (MHz)	Ant. H. (m)	Table (°)	Correction Factors (Db)	(DbµV/m)		Limit (DbµV/m)		Margin (Db)
				Peak	Average	Peak	Ave.	
2037.50	1.00	52	1.96	46.30	---	74.00	53.96	-7.66
2581.25	1.00	175	3.61	50.77	---	74.00	53.96	-3.19
4823.97	1.00	166	3.76	53.53	50.03	74.00	53.96	-3.93
7238.58	1.00	251	10.10	49.04	---	74.00	53.96	-4.92
9647.93	1.00	33	11.46	52.23	51.23	74.00	53.96	-2.73

Note:

1. Margin = Corrected – Limit.
2. The EUT utilizes a *permanently attached antenna*. In addition the spurious RF Radiated emissions levels do comply with the *20dBc limit* both at its bandedges and other spurious emissions.
3. As stated in Section 15.35(b), for any frequencies above 1000MHz, radiated limits shown are based upon the use of measurement instrumentation employing an average detector function. As the results of our test, the peak amplitudes are already below the FCC limit. Thus the average amplitudes of the rest are omitted.

Table 9 Radiated Emissions for 1GHz to 25GHz [Ant. Polarity Horizontal] [CH 6]

Radiated Emission				Corrected Amplitude		FCC Class B (3m)		
Frequency (MHz)	Ant. H. (m)	Table (°)	Correction Factors (dB)	(dBµV/m)		Limit (dBµV/m)		Margin (dB)
				Peak	Average	Peak	Ave.	
4875.08	1.00	56	3.96	52.07	---	74.00	53.96	-1.89
7313.50	1.00	175	10.30	45.91	---	74.00	53.96	-8.05
9749.50	1.00	188	11.90	48.17	---	74.00	53.96	-5.79

Table 10 Radiated Emissions for 1GHz to 25GHz [Ant. Polarity Vertical] [CH 6]

Radiated Emission				Corrected Amplitude		FCC Class B (3m)		
Frequency (MHz)	Ant. H. (m)	Table (°)	Correction Factors (dB)	(dBµV/m)		Limit (dBµV/m)		Margin (dB)
				Peak	Average	Peak	Ave.	
2062.50	1.00	62	2.05	46.71	---	74.00	53.96	-7.25
2350.99	1.00	150	3.01	52.34	41.68	74.00	53.96	-12.28
4873.94	1.00	22	3.96	55.23	52.07	74.00	53.96	-1.89
7313.50	1.00	8	10.30	51.91	---	74.00	53.96	-2.05
9747.93	1.00	304	11.89	54.00	52.83	74.00	53.96	-1.13
12185.50	1.00	55	9.73	45.17	---	74.00	53.96	-8.79

Table 11 Radiated Emissions for 1GHz to 25GHz [Ant. Polarity Horizontal] [CH 11]

Radiated Emission				Corrected Amplitude		FCC Class B (3m)		
Frequency (MHz)	Ant. H. (m)	Table (°)	Correction Factors (dB)	(dBµV/m)		Limit (dBµV/m)		Margin (dB)
				Peak	Average	Peak	Ave.	
2307.29	1.00	141	2.86	49.36	---	74.00	53.96	-4.60
2343.75	1.00	79	2.98	49.31	---	74.00	53.96	-4.65
4923.42	1.00	148	4.12	51.56	---	74.00	53.96	-2.40
6015.75	1.00	164	6.79	40.06	---	74.00	53.96	-13.90
7386.00	1.00	225	10.42	46.36	---	74.00	53.96	-7.60
9848.58	1.00	37	11.93	49.54	---	74.00	53.96	-4.42

Table 12 Radiated Emissions for 1GHz to 25GHz [Ant. Polarity Vertical] [CH 11]

Radiated Emission				Corrected Amplitude		FCC Class B (3m)		
Frequency (MHz)	Ant. H. (m)	Table (°)	Correction Factors (dB)	(dBµV/m)		Limit (dBµV/m)		Margin (dB)
				Peak	Average	Peak	Ave.	
2308.00	1.00	351	2.86	53.36	47.03	74.00	53.96	-6.93
2395.98	1.00	22	3.15	55.49	49.48	74.00	53.96	-4.48
4923.92	1.00	84	4.12	54.90	50.89	74.00	53.96	-3.07
7388.42	1.00	198	10.42	50.86	---	74.00	53.96	-3.10
9847.93	1.00	22	11.93	54.70	52.91	74.00	53.96	-1.05
12311.17	1.00	71	9.54	45.98	---	74.00	53.96	-7.98

8.4 Test Result of the Bandedge

If any 100 kHz bandwidth outside these frequency bands, the radio frequency power that is produced by the modulation products of the spreading sequence, the information sequence and the carrier frequency shall be either *at least 20 dB below that in any 100 kHz bandwidth within the band that contains the highest level of the desired power or shall not exceed the general levels specified in § 15.209(a)*,

We perform this section by the *radiated* manner, the RBW is set to 100kHz and VBW>RBW. We'd made the observation *up to 10th harmonics and the criterion is all the harmonic/spurious emissions must be 20dB below the highest emission level measured*. If the emissions fall in the restricted bands stated in the Part15.205(a) must also *comply with the radiated emission limits specified in Part15.209(a)*. (*Peak mode: RBW=VBW=1MHz, Average mode: RBW=1MHz; VBW=10Hz*)

The following pages show our observations referring to the channel 1 and 11 respectively.

Test Condition & Setup: same as < 8.1 >

Channel 1

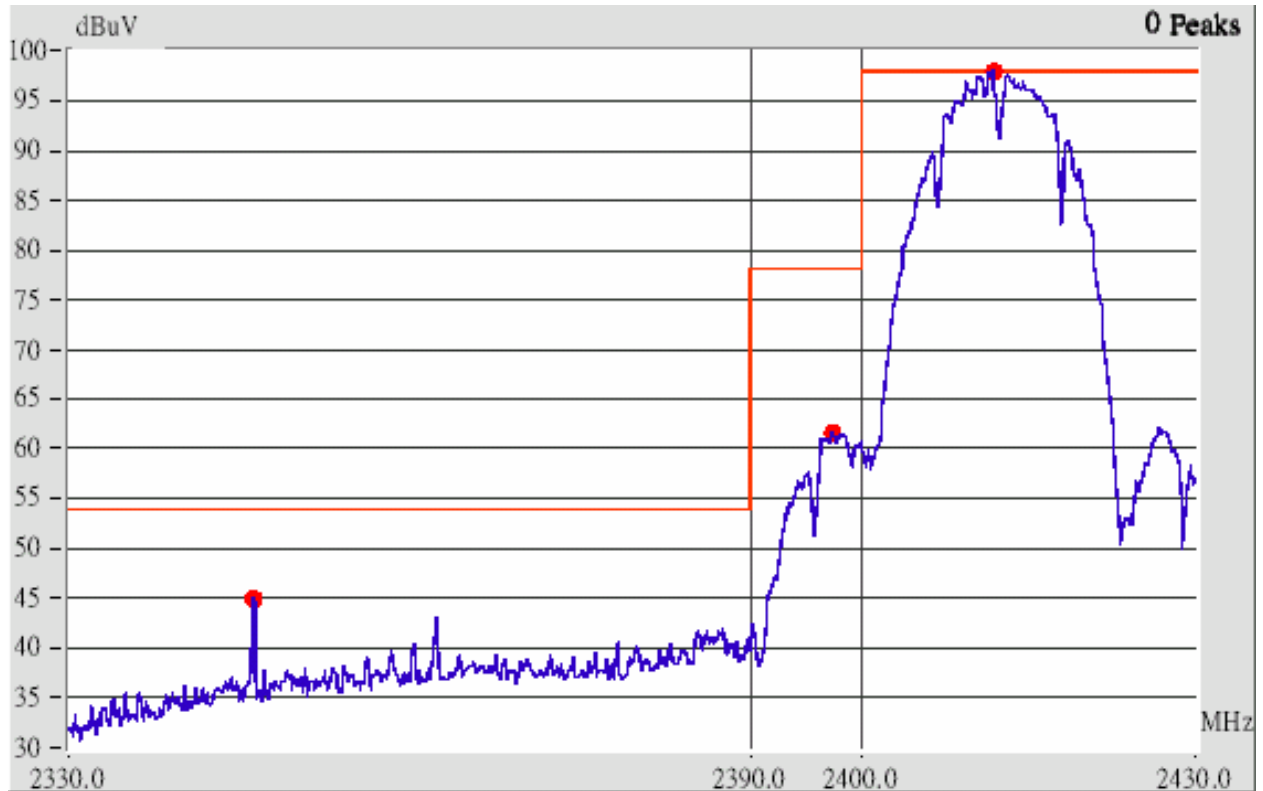

This is the hard copy of our bandedge measurement generated by our bandedge testing program. The plot shown above is the bandedge of channel 1.

1. The lobe left by the fundamental side is already 20dB below the highest emission level.
2. The emissions recorded in the restricted band is do comply with the Part 15.209(a) – as below.

<i>Radiated Emission</i>					<i>Corrected Amplitude</i>		<i>FCC Class B (3m)</i>		
<i>Frequency (MHz)</i>	<i>Ant. P.</i>	<i>Ant. H. (m)</i>	<i>Table (°)</i>	<i>Factors (dB)</i>	<i>(dBuV/m)</i>		<i>Limit (dBuV/m)</i>		<i>Margin (dB)</i>
					<i>Peak</i>	<i>Average</i>	<i>Peak</i>	<i>Ave.</i>	
2346.03	Hor	1.00	85	2.99	47.32	---	74.00	53.96	-6.64
2383.95	Hor	1.00	164	3.11	48.45	---	74.00	53.96	-5.51
2390.07	Hor	1.00	11	3.14	46.64	---	74.00	53.96	-7.32
2346.14	Ver	1.00	288	2.99	51.99	---	74.00	53.96	-1.97
2387.36	Ver	1.00	29	3.13	52.96	---	74.00	53.96	-1.00
2390.07	Ver	1.00	46	3.14	52.14	---	74.00	53.96	-1.82

Channel 11



This is the hard copy of our bandedge measurement generated by our bandedge testing program. The plot shown above is the bandedge of channel 11.

1. The lobe right by the fundamental side is already 20dB below the highest emission level.
2. The emissions recorded in the restricted band is do comply with the Part 15.209(a) – as below

<i>Radiated Emission</i>					<i>Corrected Amplitude</i>		<i>FCC Class B (3m)</i>		
<i>Frequency (MHz)</i>	<i>Ant. P.</i>	<i>Ant. H. (m)</i>	<i>Table (°)</i>	<i>Factors (dB)</i>	<i>(dBµV/m)</i>		<i>Limit (dBµV/m)</i>		<i>Margin (dB)</i>
					<i>Peak</i>	<i>Average</i>	<i>Peak</i>	<i>Ave.</i>	
2483.50	Hor	1.00	94	3.45	45.11	---	74.00	53.96	-8.85
2484.26	Hor	1.00	172	3.45	47.11	---	74.00	53.96	-6.85
2502.75	Hor	1.00	160	3.50	47.34	---	74.00	53.96	-6.62
2483.50	Ver	1.00	29	3.45	52.28	---	74.00	53.96	-1.68
2484.20	Ver	1.00	306	3.50	53.45	---	74.00	53.96	-0.51
2500.65	Ver	1.00	184	3.50	51.17	---	74.00	53.96	-2.79

IX. Section 15.247(d): Power Spectral Density

9.1 Test Condition & Setup

The tests below are running with the EUT transmitter set at high power in TDD mode. The EUT is needed to force selection of output power level and channel number. While testing, the EUT was set to transmit continuously and to be tested by the contact manner with the spectrum analyzer.

The attachments below show our observation.

9.2 Test Instruments Configuration

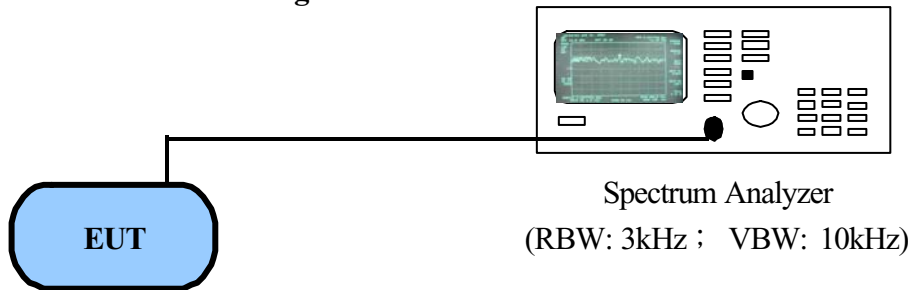

P.S.: Notebook computer to control the EUT at maximal power output and channel number and set antenna kit

Test Configuration of Power Spectral Density

9.3 List of Test Instruments

Instrument Name	Model No.	Brand	Serial No.	Last time	Next time
Spectrum Analyzer	MS2665C	ANRITSU	6200175476	09/11/02	09/11/03

9.4 Test Result of Power spectral density

The following table shows a summary of the test results of the Power Spectral Density.

<i>Channel</i>	<i>Frequency (GHz)</i>	<i>Ppr (dBm)</i>	<i>Cable Loss (dB)</i>	<i>Ppq (dBm)</i>	<i>Limit (dB)</i>	<i>Margin (dB)</i>
CH 01	2.412	-8.17	1.80	-6.37	8.00	-14.37
CH 06	2.437	-8.10	1.85	-6.25	8.00	-14.25
CH 11	2.462	-7.92	1.93	-5.99	8.00	-13.99

Note:

1. The attachment following by this page.
2. Ppr: spectrum read power density (using peak search mode),
Ppq: actual peak power density in the spread spectrum band.
3. $Ppq = Ppr + |Cable Loss|$

Channel 01

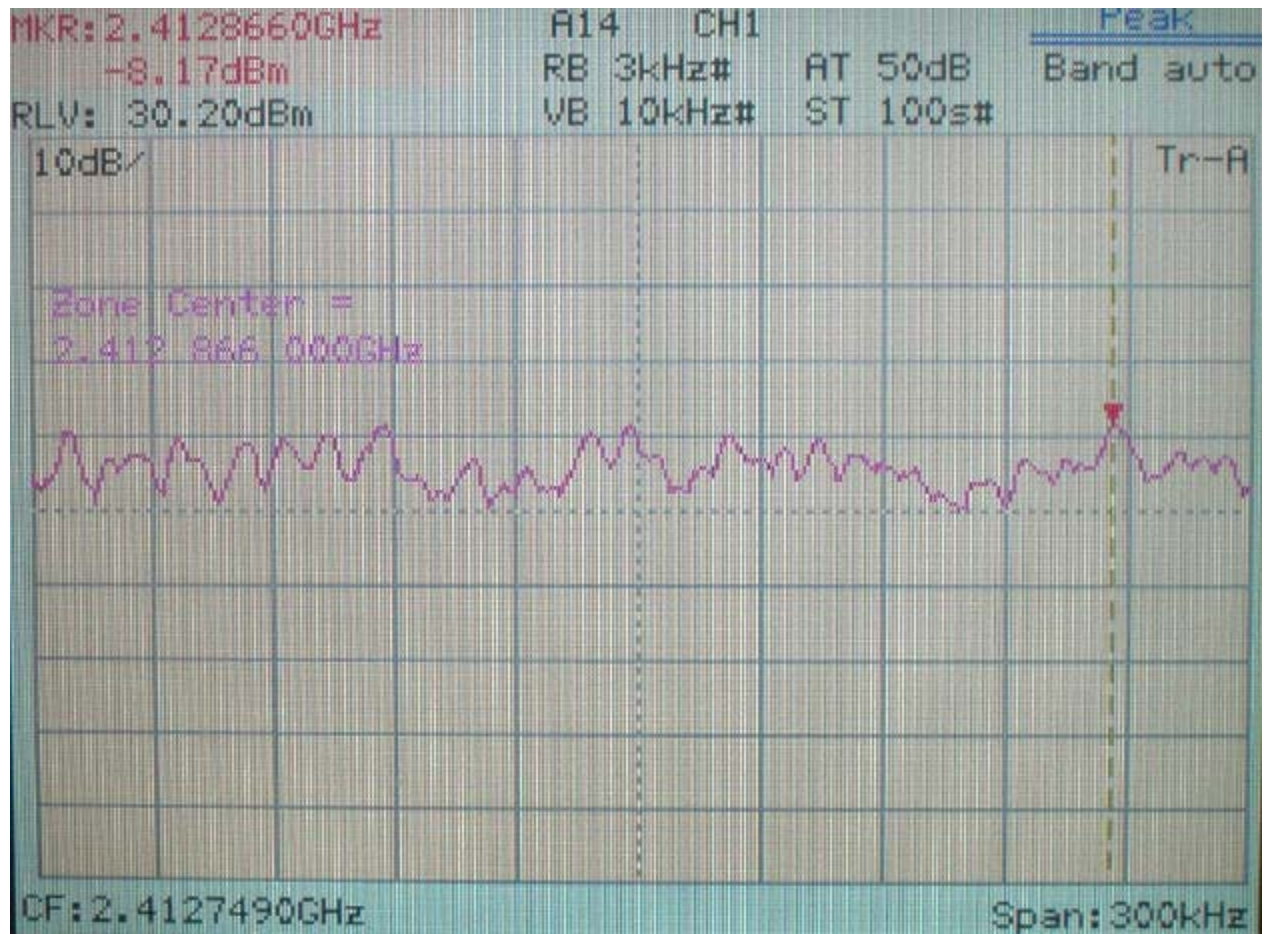

Channel 06

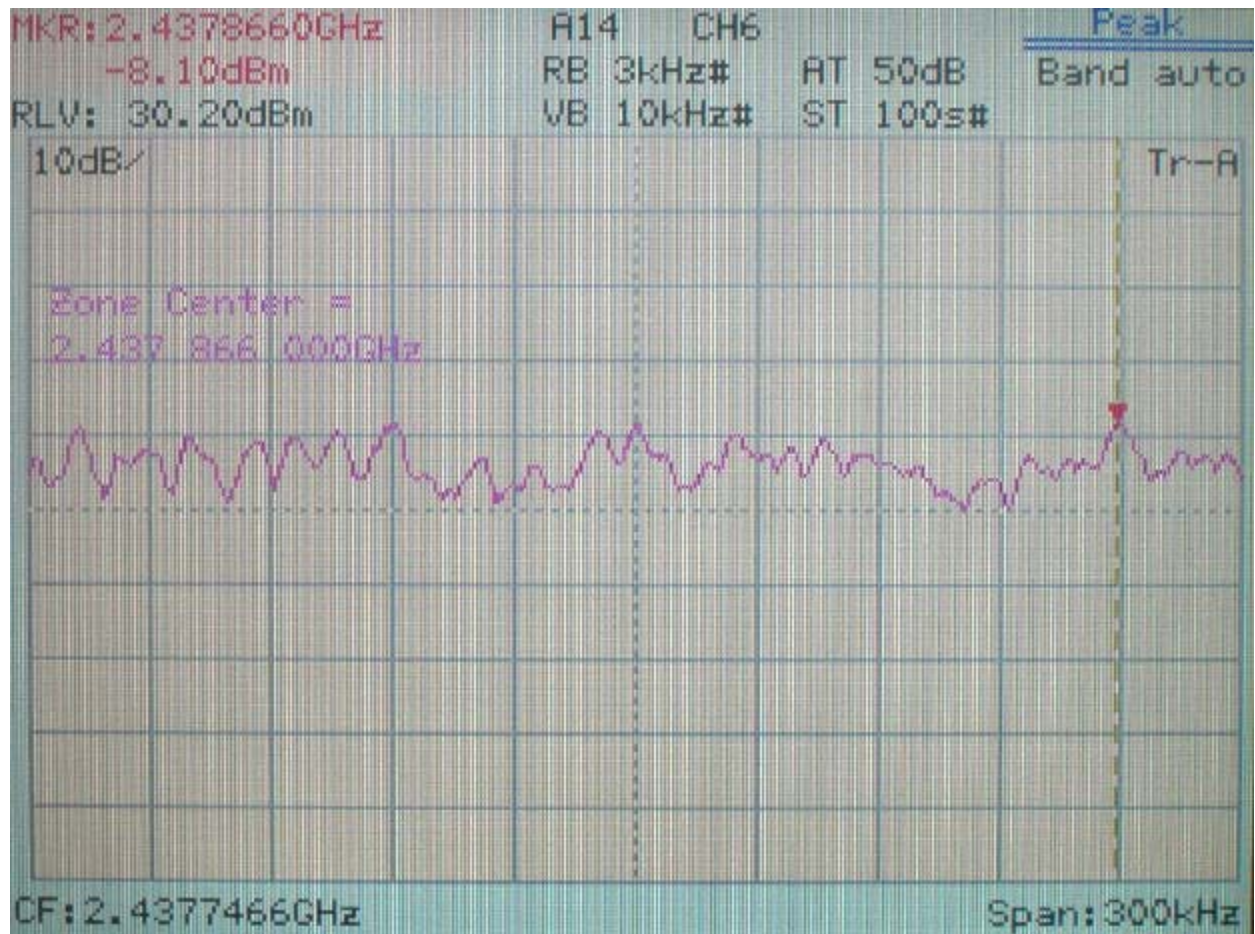

Channel 11

