

# MEASUREMENT REPORT of WIRELESS ACCESS POINT

**Applicant** : TeLLUS GROUP CORPORATION  
**Model No.** : TWL-A11  
**EUT** : TeLLUS WLAN Access Point  
**FCC ID** : PB6-00091  
**Report No.** : T6915979

Tested by :

*Training Research Co., Ltd.*

TEL : 886-2-26935155

FAX : 886-2-26934440

2, Lane 194, Huan-Ho Street, Hsichih, Taipei Hsien 221, Taiwan, R.O.C.

# CERTIFICATION

**We here by verify that:**

The test data, data evaluation, test procedures and equipment configurations shown in this report were made mainly in accordance with the procedures given in ANSI C63.4 (1992) as a reference. All test were conducted by *Training Research Co., Ltd.*, 2, Lane 194, Huan-Ho Street, Hsichih, Taipei Hsien 221, Taiwan, R.O.C. Also, we attest to the accuracy of each.

We further submit that the energy emitted by the sample EUT tested as described in the report is in compliance with the technical requirements set forth in the FCC Rules Part 15 Subpart C Section 15.247.

**Applicant** : TeLLUS GROUP CORPORATION

**Model No.** : TWL-A11

**EUT** : TeLLUS WLAN Access Point

**FCC ID** : TB6-00091

**Report No.** : T6915979

**Test Date** : January 21, 2002

Prepared by:

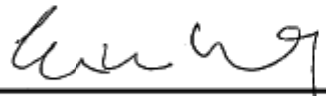
  
Eric Wong

Approved by:

  
Frank Tsai

Tested by :

***Training Research Co., Ltd.***

TEL: 886-2-26935155

FAX: 886-2-26934440

2, Lane 194, Huan-Ho Street, Hsichih, Taipei Hsien 221, Taiwan, R.O.C.

---

Report No.: T6915979

Training Research Co., Ltd., TEL: 886-2-26935155, Fax: 886-2-26934440

## *Tables of Contents*

<b>I. GENERAL</b> .....	5
1.1 Introduction .....	5
1.2 Description of EUT .....	6
1.3 Description of Support Equipment .....	7
1.4 Configuration of System Under Test .....	7
1.5 Verify the Frequency and Channel .....	8
1.6 Test Procedure .....	9
1.7 Location of the Test Site .....	9
1.8 General Test Condition .....	9
<b>II. Section 15.203 : Antenna Requirement</b> .....	10
<b>III. Section 15.207: Power Line Conducted Emissions for AC Powered Units</b> .....	11
3.1 Test Condition & Setup .....	11
3.2 List of Test Instruments .....	11
3.3 Test Configuration .....	12
3.4 Test Result of Conducted Emissions .....	13
<b>IV. Section 15.247(a) : Technical Description of the EUT</b> .....	16
<b>V. Section 15.247(a)(2): Bandwidth for Direct Sequence System</b> .....	17
5.1 Test Condition & Setup .....	17
5.2 Test Instruments Configuration .....	17
5.3 List of Test Instruments .....	17
5.4 Test Result of Bandwidth .....	18
<b>VI. Section 15.247(b) : Power Output</b> .....	22
6.1 Test Condition & Setup .....	22
6.2 List of Test Instruments .....	23
6.3 Test Result .....	23
<b>VII. Section 15.247(c) : Spurious Emissions (Radiated)</b> .....	26
7.1 Test Condition & Setup .....	26
7.2 List of Test Instruments .....	27
7.3 Test Instruments Configuration .....	28
7.4 Test Result of Spurious Radiated Emissions .....	29
7.5 Test Result of Bandedge.....	36
<b>VIII. Section 15.247(d) : Power Spectral Density</b> .....	39
8.1 Test Condition & Setup .....	39
8.2 Test Instruments Configuration .....	40
8.3 List of Test Instruments .....	40
8.4 Test Result of Power Spectral Density .....	41

***Test Report*** ----- 4/46  
**Appendix A: Set Up Procedure** ..... 45  
**Appendix B: Antenna Specification** ..... 46

**. GENERAL**

**1.1 Introduction**

The following measurement report is submitted on behalf of Applicant in support of a wireless access point certification in accordance with Part 2 Subpart J and Part 15 Subpart A and C of the Commission's Rules and Regulations.

**1.2 Description of EUT**

- EUT** : TeLLUS WLAN Access Point
- Model No.** : TWL-A11
- Granted FCC ID** : PB6-00091
- Frequency Range** : 2.412 GHz ~ 2.462GHz
- Antenna Kit** : 2 SX connectors for external antennas
- Supported Channel:** 11 Channel
- Modulation Skill** : DBPSK, DQPSK, CCK
- Power Cable** : Non-shielded, 190cm long, No bead
- Data Cable** : RJ45: Non-shielded, 10-meter, No ferrite bead
- Power Type** : AC to DC Switching Adapter  
Input: 100 ~ 240VAC, 47/63Hz, 0.3A  
Output: +5VDC, 1.5A
- Applicant** : TeLLUS GROUP CORPORATION.  
4/F, 15 Industry E Rd. IX, Science-Based Industrial Park, Hsinchu,  
Taiwan, R.O.C.

### 1.3 Description of Support Equipment

In order to construct the minimum testing, following equipment were used as the support units.

**Notebook** : **IBM**  
Type No. : 2626-11T  
Serial No. : FX-11922-00109  
FCC ID : DoC Approved

**AC Adaptor** : **DELTA ELECTRONICS, INC.**  
Model No. : 02K6549  
Serial No. : 11S2510035032AA004Y0  
FCC ID : DoC Approved  
Power Core : Non-shielded, Plastic hoods, with ferrite bead  
Power type : 100 ~ 240VAC, 50 ~ 60Hz, 1.2A / 16VDC, 3.36A

**HUB** : **Cameo Communications, Inc.**  
Model No. : SOHO-SW16A  
Serial No. : N/A  
Power Type : Switch  
FCC ID : N/A, DoC Approved  
Power cord : Non-shielded, 1.95m long, Plastic, No ferrite core

1.4 Configuration of System Under Test

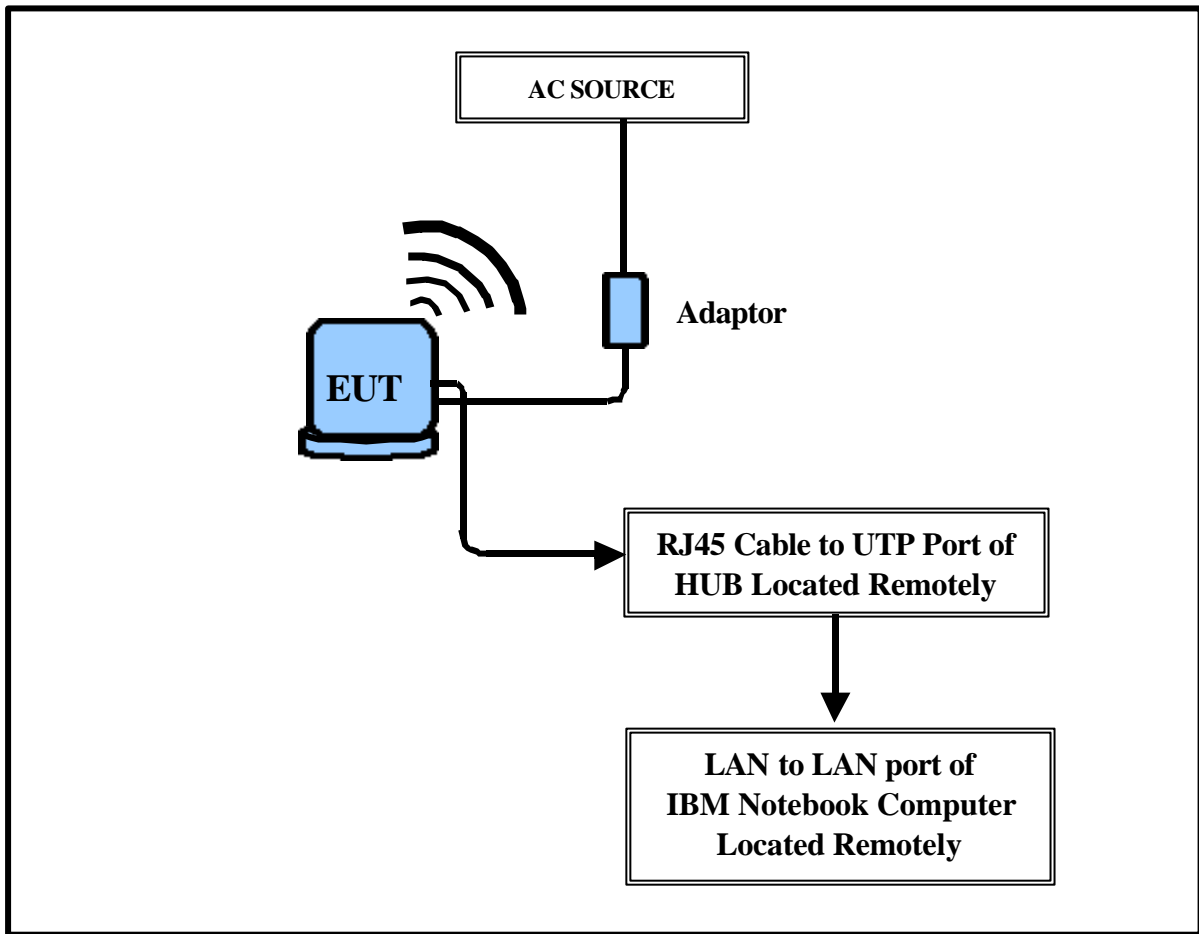

Fig. 1 Configuration of system under test

The tests below are run with the EUT transmitter set at high power in TDD mode. A LAN from a LAN port of notebook computer to the Ethernet HUB then UTP port of hub connected to UTP port of EUT by RJ45 cable. The EUT is needed to force selection of output power level and channel number by notebook computer.

The setting up procedure was recorded in <Appendix A.>.

**1.5 Verify the Frequency and Channel**

Channel	Frequency (GHz)
1	2.412
2	2.417
3	2.422
4	2.427
5	2.432
6	2.437
7	2.442
8	2.447
9	2.452
10	2.457
11	2.462

Note:

1. This is for sure that all frequencies are in 2.412GHz to 2.462GHz.
2. Section 15.31(m): Measurements on intentional radiators or receivers shall be performed at three frequencies for operating frequency range over 10 MHz.  
(The locations of these frequencies one near the top, one near the middle and one near the bottom.)

After tests, the EUT operating frequencies are in 2.412GHz to 2.462GHz. So all the items as followed in testing report are need to test these three frequencies:

Top: Channel – 1; Middle: Channel – 6; Bottom: Channel – 11.



## **1.6 Test Procedure**

All measurements contained in this report were performed mainly according to the techniques described in ANSI C63.4 (1992) and the pre-setup was written on Appendix A, the detail setup was written on each test item.

## **1.7 Location of the Test Site**

The radiated emissions measurements required by the rules were performed on the **three-meter, Anechoic Chamber (Registration Number: 93906)** maintained by *Training Research Co., Ltd.* 1F, No. 2, Lane 194, Huan-Ho Street, Hsichih, Taipei Hsien 221, Taiwan, R.O.C. Complete description and measurement data have been placed on file with the commission. The conducted power line emissions tests and other test items were performed in a anechoic chamber also located at Training Research Co., Ltd.

No. 2, Lane 194, Huan-Ho Street, Hsichih, Taipei Hsien 221, Taiwan, R.O.C. *Training Research Co., Ltd.* is listed by the FCC as a facility available to do measurement work for others on a contract basis.

## **1.8 General Test Condition**

The conditions under which the EUT operates were varied to determine their effect on the equipment's emission characteristics. The final configuration of the test system and the mode of operation used during these tests were chosen as that which produced the highest emission levels. However, only those conditions, which the EUT was considered likely to encounter in normal use were investigated.

In test, they were set in high power and continuously transmitting mode that controlled by notebook computer. The Ch01, Ch06 and Ch11 of EUT were all tested. The setting up procedure is recorded on <Appendix A>.

## **II. Section 15.203 : Antenna Requirement**

The EUT equipped with 2 *SX connectors for the external antennas*. Such connectors, like MMCX connector, meet the requirements on the Sect.15.203 as it fails the "Radio Shack Test". This means we cannot find this connector commonly available in retail stores. In addition, the EUT is equipped no other connectors for the extra antenna. The statement of cannot remove it freely without any tools from outside is not applied. This complies with the Antenna requirement stated in Sect.15.203.

**III. Section 15.207: Power Line Conducted Emissions for AC Powered Units**

**3.1 Test Condition & Setup**

The power line conducted emission measurements were performed in an anechoic chamber. The EUT was assembled on a wooden table, which is 80 centimeters high, was placed 40 centimeters from the back-wall and at least 1 meter from the side-wall.

Power was fed to the EUT from the public utility power grid through a line filter and Line Impedance Stabilization Networks (LISNs). The LISN housing, measuring instrumentation case, ground plane, etc., were electrically bonded together at the same RF potential. The Spectrum analyzer (or EMI receiver) was connected to the AC line through an isolation transformer. The 50-ohm output of the LISN was connected to the spectrum analyzer directly. Conducted emission levels were in the CISPER quasi-peak detection mode. The analyzer's 6 dB bandwidth was set to 9 KHz. No post-detector video filter was used.

The spectrum was scanned from 450 KHz to 30 MHz. The physical arrangement of the test system and associated cabling was varied (within the scope of arrangements likely to be encountered in actual use) to determine the effect on the unit's emanations in amplitude and frequency. All spurious emission frequencies were observed. The highest emission amplitudes relative to the appropriate limit were measured and have been recorded in paragraph 2.4.

There is a test condition apply in this test item, the test procedure description as follow:

EUT transmit only:

Using LAN port of notebook computer and software to control the EUT through. Then making access to the mode of continuous transmission and set testing channel and internal antenna kit. Three channels were tested, one in the top (CH01), one in the middle (CH06) and the other in bottom (CH11).

The setting up procedure is recorded on <Appendix A>.

**3.2 List of Test Instruments**

<u>Instrument Name</u>	<u>Model No.</u>	<u>Brand</u>	<u>Serial No.</u>	<u>Last time</u>	<u>Next time</u>
EMI Receiver	8546A	H P	3520A00242	06/29/01	06/29/02
RF Filter Section	85460A	H P	3448A00217	06/29/01	06/29/02
LISN (EUT)	LISN-01	TRC	9912-03,04	12/09/01	12/09/02
LISN (Support E.)	LISN-01	TRC	9912-05	01/04/02	01/04/03
Switch/Control Unit (< 30MHz)	3488A	HP	N/A	11/20/01	11/20/02
Auto Switch Box (< 30MHz)	ASB-01	TRC	9904-01	11/20/01	11/20/02

3.3 Test configuration

*Conducted Emissions Test Placement*



**3.4 Test Result of Conducted Emissions**

**EUT station transmit only**

The following table shows a summary of the highest emissions of power line conducted emissions on the LINE and NETURAL conductors of the EUT power cord.

**Table 1 Power Line Conducted Emissions (Channel 1, Transmitter Mode)**

Test Conditions: Testing room : Temperature : 20.3 ° C Humidity : 67 % RH

Testing site : Temperature : 21.1 ° C Humidity : 72 % RH

<i>Power Connected Emissions</i>				<i>FCC Class B</i>	
<i>Conductor</i>	<i>Frequency (KHz)</i>	<i>Peak Amplitude (dB μ V)</i>	<i>QP Amplitude (dB μ V)</i>	<i>Limit (dB μ V)</i>	<i>Margin (dB)</i>
Line 1	590.00	42.14	---	48.00	-5.86
	3240.00	39.97	---	48.00	-8.03
	4000.00	44.58	---	48.00	-3.42
	4140.00	41.63	---	48.00	-6.37
	4220.00	43.25	---	48.00	-4.75
	4420.00	49.44	42.42	48.00	-5.58
	4610.00	50.62	43.67	48.00	-4.33
	4740.00	44.28	---	48.00	-3.72
	5120.00	45.55	---	48.00	-2.45
	5220.00	42.65	---	48.00	-5.35
Line 2	590.00	40.55	---	48.00	-7.45
	4030.00	45.69	---	48.00	-2.31
	4140.00	46.35	---	48.00	-1.65
	4220.00	47.71	---	48.00	-0.29
	4420.00	47.13	---	48.00	-0.87
	4510.00	47.33	---	48.00	-0.67
	4740.00	48.28	41.92	48.00	-6.08
	5290.00	41.42	---	48.00	-6.58
	5390.00	41.39	---	48.00	-6.61
	5490.00	40.99	---	48.00	-7.01

NOTE:

1. Margin = Peak Amplitude - Limit
2. A "+" sign in the margin column means the emission is OVER the Class B Limit and "-" sign of means UNDER the Class B limit

**Table 2 Power Line Conducted Emissions (Channel 6, Transmitter Mode)**

Test Conditions: Testing room : Temperature : 20.3 ° C Humidity : 67 % RH  
 Testing site : Temperature : 21.1 ° C Humidity : 72 % RH

<i>Power Connected Emissions</i>				<i>FCC Class B</i>	
<i>Conductor</i>	<i>Frequency (KHz)</i>	<i>Peak Amplitude (dB μ V)</i>	<i>QP Amplitude (dB μ V)</i>	<i>Limit (dB μ V)</i>	<i>Margin (dB)</i>
Line 1	590.00	42.22	---	48.00	-5.78
	3130.00	39.97	---	48.00	-8.03
	4000.00	43.34	---	48.00	-4.66
	4140.00	42.36	---	48.00	-5.64
	4300.00	46.78	---	48.00	-1.22
	4420.00	46.61	---	48.00	-1.39
	4610.00	50.53	43.45	48.00	-4.55
	4910.00	47.57	---	48.00	-0.43
	5220.00	42.63	---	48.00	-5.37
	5390.00	43.03	---	48.00	-4.97
Line 2	590.00	41.05	---	48.00	-6.95
	3920.00	43.26	---	48.00	-4.74
	4220.00	47.59	---	48.00	-0.41
	4420.00	48.56	42.90	48.00	-5.10
	4610.00	50.60	43.41	48.00	-4.59
	4740.00	48.12	42.20	48.00	-5.80
	4980.00	46.98	---	48.00	-1.02
	5220.00	42.41	---	48.00	-5.59
	5390.00	41.77	---	48.00	-6.23
	5490.00	40.55	---	48.00	-7.45

**\*The reading amplitudes are all under limit.**

**Table 3 Power Line Conducted Emissions (Channel 11, Transmitter Mode)**

Test Conditions: Testing room : Temperature : 20.3 ° C Humidity : 67 % RH

Testing site : Temperature : 21.1 ° C Humidity : 72 % RH

<i>Power Connected Emissions</i>				<i>FCC Class B</i>	
<i>Conductor</i>	<i>Frequency (KHz)</i>	<i>Peak Amplitude (dB μ V)</i>	<i>QP Amplitude (dB μ V)</i>	<i>Limit (dB μ V)</i>	<i>Margin (dB)</i>
Line 1	590.00	42.22	---	48.00	-5.78
	4000.00	45.87	---	48.00	-2.13
	4140.00	45.75	---	48.00	-2.25
	4300.00	46.62	---	48.00	-1.38
	4420.00	48.94	42.23	48.00	-5.77
	4610.00	49.99	43.64	48.00	-4.36
	4740.00	46.71	---	48.00	-1.29
	4910.00	47.54	---	48.00	-0.46
	5010.00	47.38	---	48.00	-0.62
	5220.00	42.45	---	48.00	-5.55
Line 2	593.00	41.00	---	48.00	-7.00
	4030.00	46.99	---	48.00	-1.01
	4140.00	44.86	---	48.00	-3.14
	4420.00	47.99	---	48.00	-0.01
	4510.00	50.35	43.52	48.00	-4.48
	4740.00	48.38	42.27	48.00	-5.73
	4910.00	45.73	---	48.00	-2.27
	5120.00	45.43	---	48.00	-2.57
	5290.00	40.71	---	48.00	-7.29
	5530.00	39.30	---	48.00	-8.70

**\*The reading amplitudes are all under limit.**

#### **IV. Section 15.247 (a): Technical description of the EUT**

Based on the Section 2.1, *Direct Sequence System* is a spread spectrum system in which the carrier has been modulated by a high speed spreading code and an information data stream. The high speed code sequence dominates the “modulating function” and is the direct cause of the wide spreading of the transmitted signal. In the *operational description* demonstrates the operation principles of the baseband processor employed by the EUT, shows that which is a complete DSSS baseband processor and meets the definition of the Direct Sequence Spread Spectrum System.



**V. Section 15.247(a)(2): Bandwidth for Direct Sequence System.**

**5.1 Test Condition & Setup**

The transmitter bandwidth measurements were performed by the contact manner. The EUT was set to transmit continuously, also various channels were investigated to find the maximum occupied bandwidth.. The output of the EUT was connected to the spectrum analyzer. The bandwidth of the fundamental frequency is observed by the spectrum analyzer with 100kHz RBW and 100kHz VBW.

**5.2 Test Instruments Configuration**

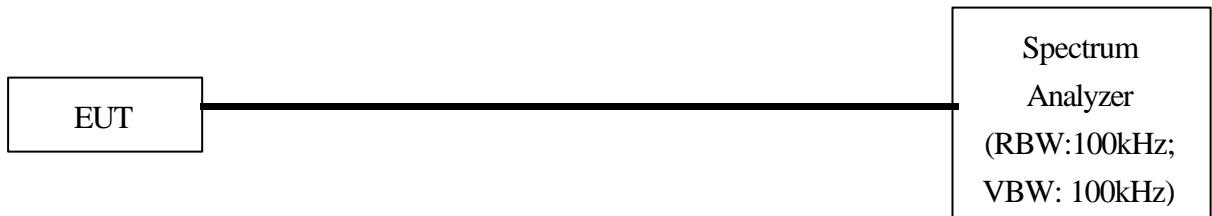

Test Configuration of Bandwidth for Direct Sequence System

*P.S.: Notebook computer to control the EUT at maximal power output and channel Number and set antenna kit*

**5.3 List of Test Instruments**

Instrument Name	Model No.	Brand	Serial No.	Last time	Next time
Spectrum Analyzer	8592A	H P	3003AD1401	01/02/02	01/01/03

**5.4 Test Result of Bandwidth**

**Bandwidth of Channel 1**

Bandwidth : 8.2 MHz

The min. 6 dB BW at least : 500 KHz

**Bandwidth of Channel 6**

Bandwidth : 8.15 MHz

The min. 6 dB BW at least : 500 KHz

**Bandwidth of Channel 11**

Bandwidth : 8.20 MHz

The min. 6 dB BW at least : 500 KHz

Note:

1. The data in the above table are summarizing the following attachment spectrum analyzer hard copy.

Bandwidth of Channel 1: 8.20 MHz



Bandwidth of Channel 6: 8.15 MHz

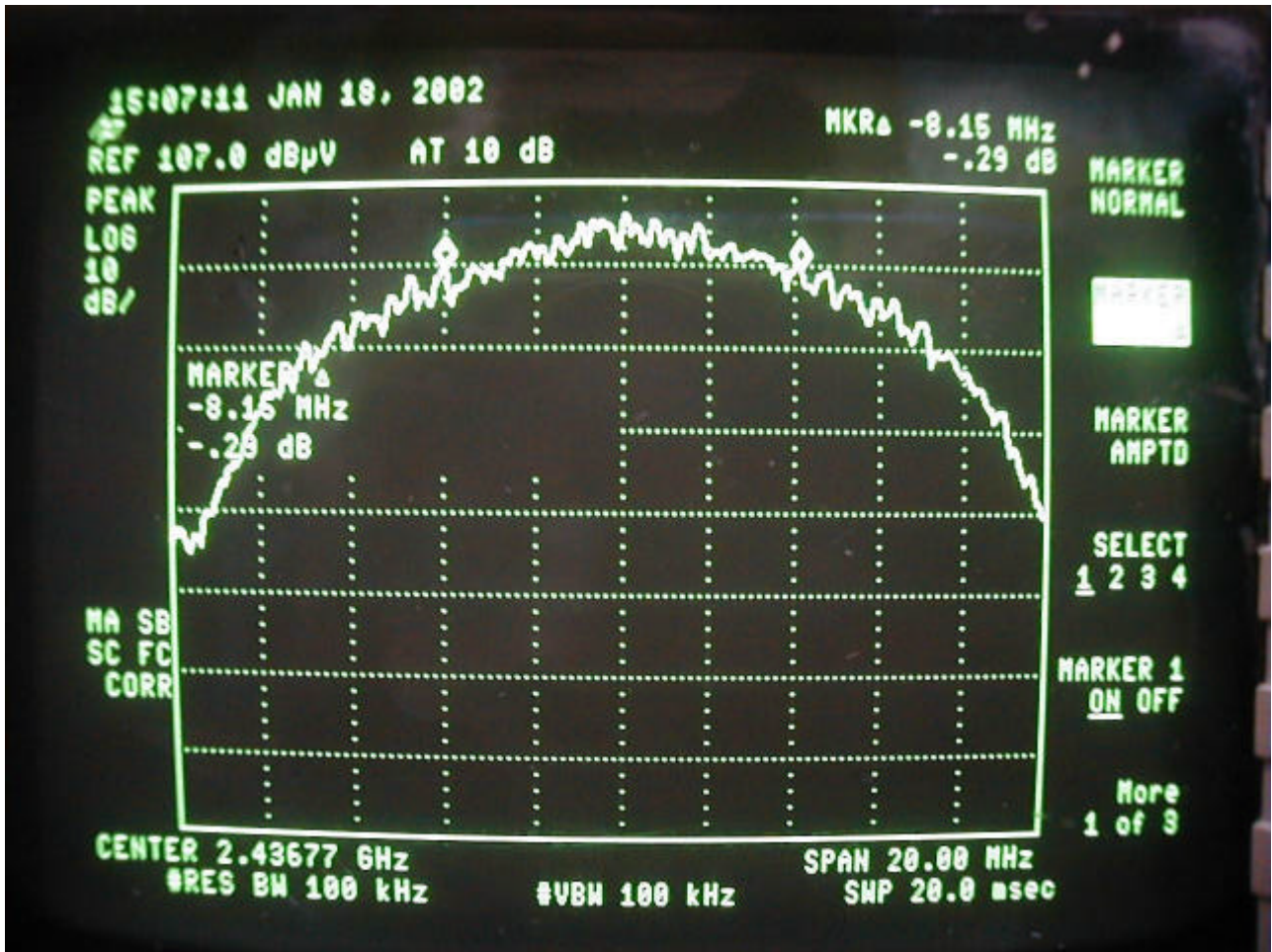

Bandwidth of Channel 11: 8.20 MHz

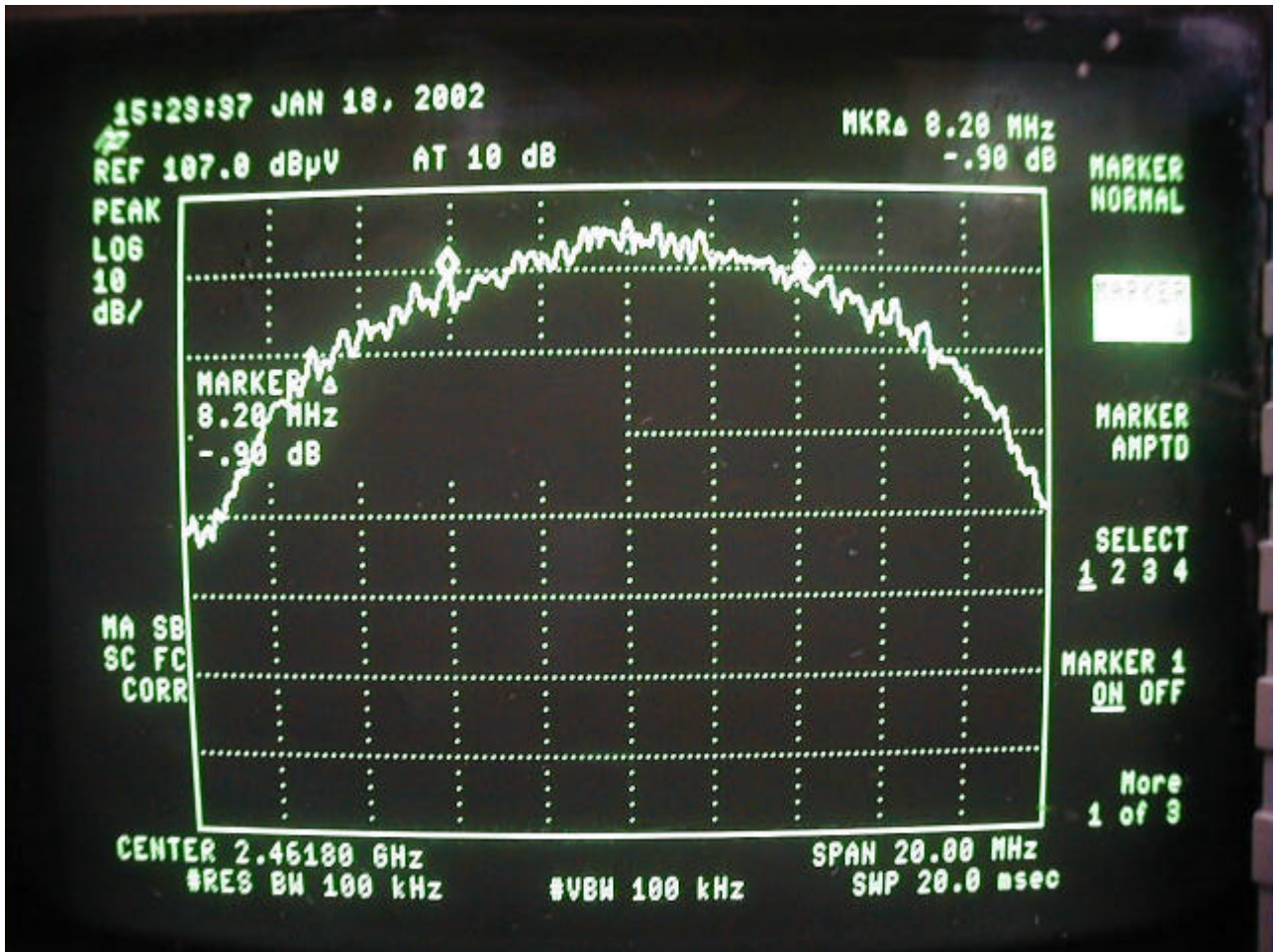

## VI. Section 15.247(b): Power Output

### 6.1 Test Condition & Setup

A:

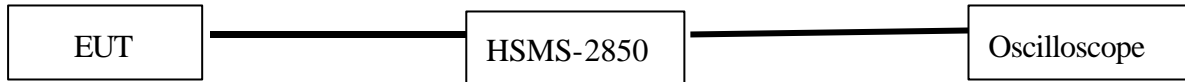

B:

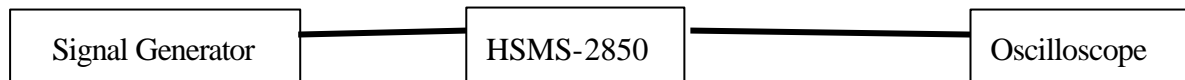

1. The output of the transmitter terminated by Schottkey Detector Diode (Hewlett- Packard HSMS-2850)
2. The output of the Shocttkey Diode Detector connected to the vertical channel of an oscilloscope. The observed trace of the oscilloscope shall be recorded as "A".
3. The combination of the diode detector and the oscilloscope capable of faithfully reproducing the envelope of peaks and duty cycle of the transmitter output signal.
4. The transmitter replaced by a signal generator. The output frequency of the signal made equal to the center of the frequency range occupied by the transmitter and unmodulated.
5. The output of the signal generator raised to reach the peak of trace "A" named X.
6. The signal generator output level  $X_mW$  is the transmitter output peak power. Recording the following.

**6.2 List of Test Instruments**

Instrument Name	Model No.	Brand	Serial No.
Oscilloscope	54600A	H P	
Signal Generator	83711A	H P	3429A00434
Shoctkey Diode	HSMS-2850	H P	
Attenuator	MCL BW- S6W2	Mini- Circuits	

**6.3 Test Result**

**Formula:**

Signal generator + Antenna gain + Cable loss = Output peak power

Channel	Signal Generator	Antenna Gain	Cable Loss	Limit	Output peak power	
	dBm	dB <i>i</i>	dB	(DTS)	dBm	mW
CH1	9.60	1.5	-0.81	100mW	10.29	10.69
CH6	8.20	1.5	-0.84	100mW	8.86	7.69
CH11	7.10	1.5	-0.87	100mW	7.73	5.929

Note:

The limit is vary according to the equipment class, listed below:

1. Digital Transmission System (DTS): 100mW
2. Spread Spectrum Transmitter (DSS): 1W

Hardcopy of the oscilloscope (w/EUT)

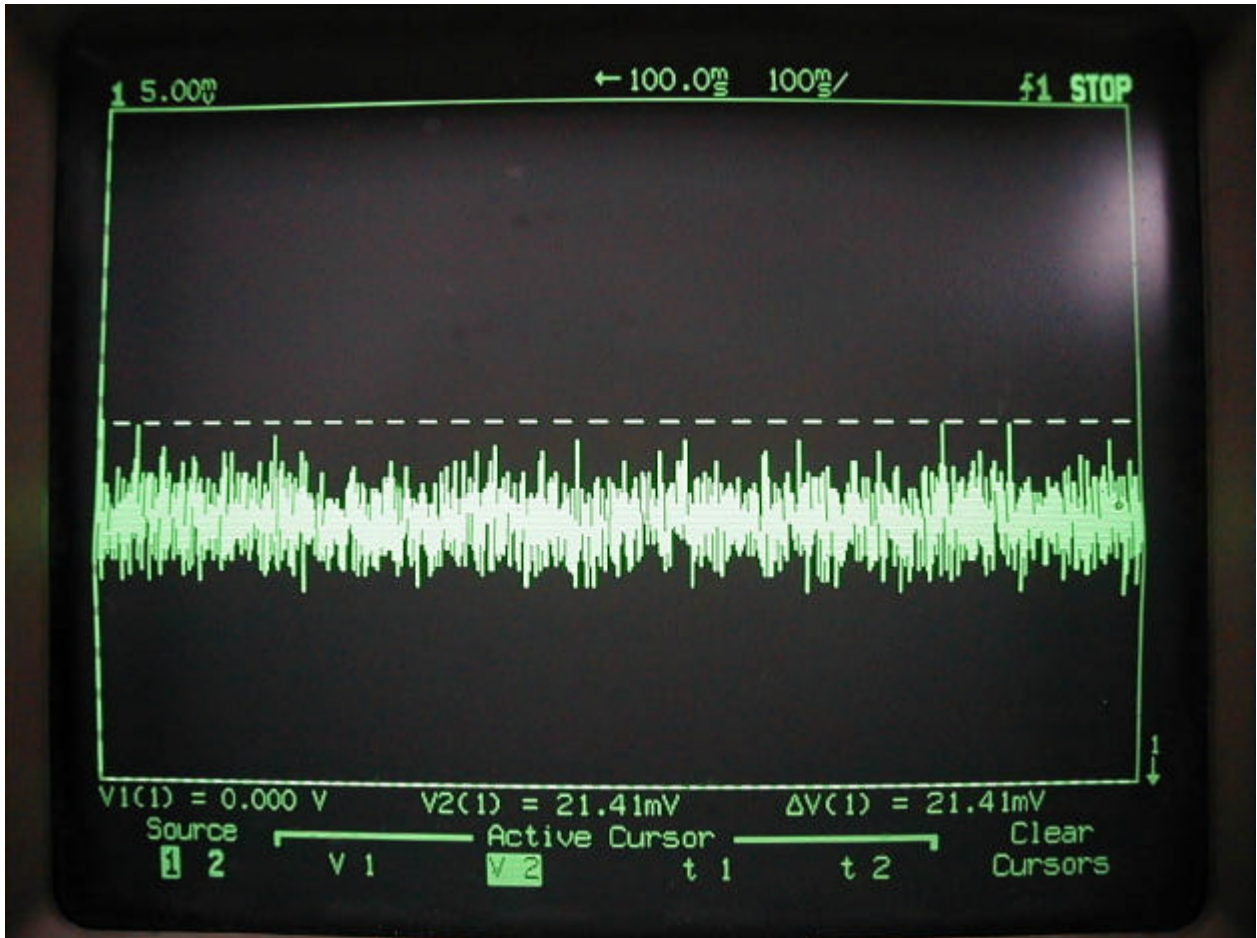



Hardcopy of the oscilloscope (w/Signal Generator)

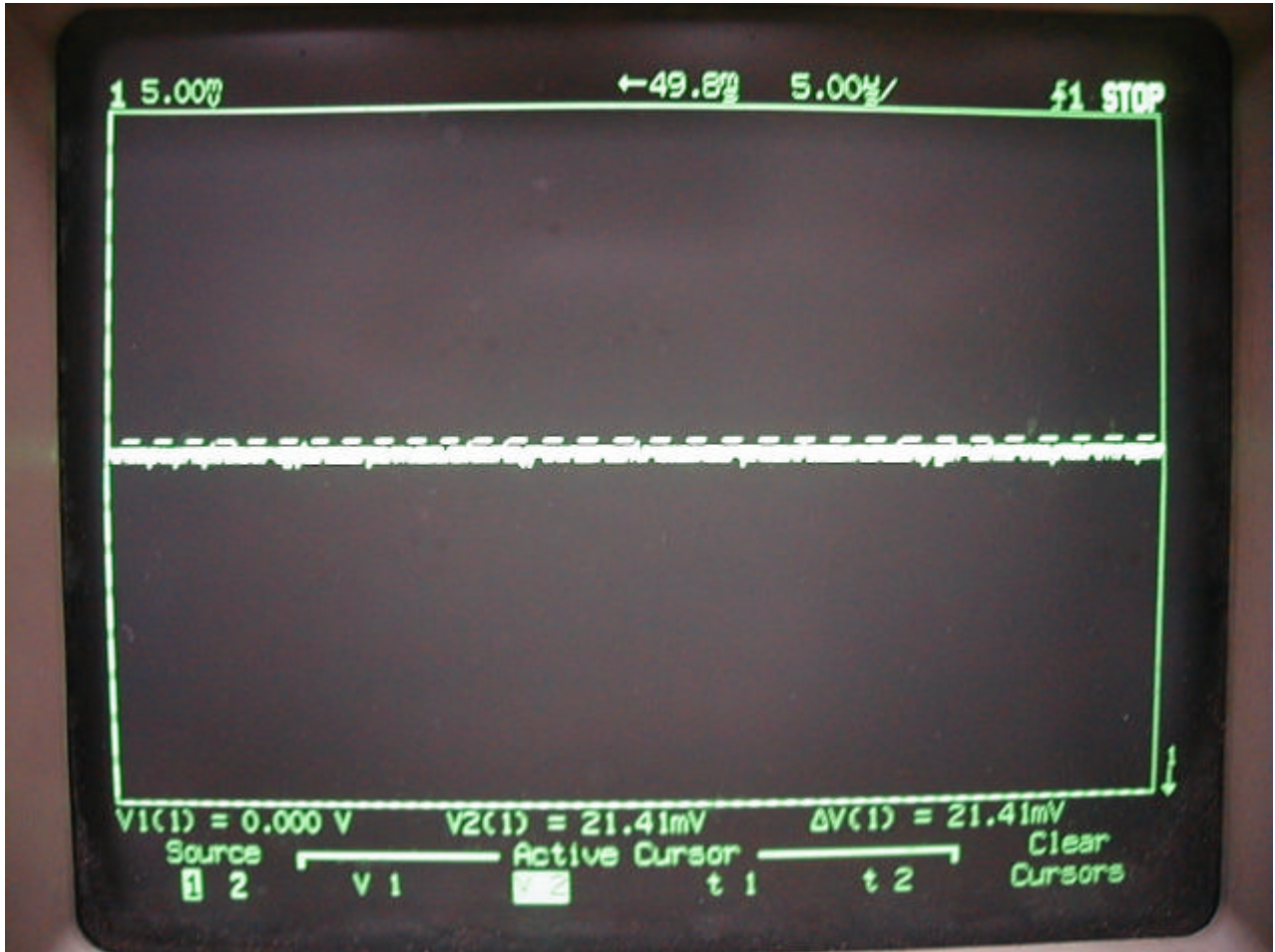

## **11. Section 15.247(c): Spurious Emissions (Radiated)**

### **7.1 Test Condition & Setup**

The EUT was placed in an anechoic chamber and scanned at 3-meter distance to determine its emission characteristics. The physical arrangement of the EUT was varied (within the scope of arrangements likely to be encountered in actual use) to determine the effect on the unit's emanations in amplitude, directivity, and frequency. The exact system configuration, which produced the highest emissions was noted so it could be reproduced later during the final tests. This was done to ensure that the final measurements would demonstrate the worst-case interference potential of the EUT.

Final radiation measurements were made on a three-meter, anechoic chamber. The EUT system was placed on a nonconductive turntable, which is 0.8 meters height, top surface 1.0 x 1.5 meter.

The spectrum was examined from 30 MHz to 1000 MHz using an Hewlett Packard 85460A EMI Receiver, Schaffner whole range Bi-Log antenna (Model No.: CBL6141A) is used to measure frequency from 30 MHz to 1GHz. The final test is used the spectrum HP 85460A and spectrum was examined from 1GHz to 18GHz using an Hewlett Packard 8564E Spectrum Analyzer, EMCO Horn Antenna (Model 3115) for 1G ~ 18GHz.

At each frequency, the EUT was rotated 360 degrees, and the antenna was raised and lowered from one to four meters to find the maximum emission levels. Measurements were taken using both horizontal and vertical antenna polarization.

Appropriate preamplifiers were used for improving sensitivity and precautions were taken to avoid overloading or desensitizing the spectrum analyzer. There are two spectrum analyzers use on this testing, HP 85460A for frequency 30MHz to 1000MHz, and 8564E for frequency 1GHz to 18GHz. No post-detector video filters were used in the test. The spectrum analyzer's 6dB bandwidth was set to 120KHz (spectrum was examined from 30 MHz to 1000 MHz) and the analyzer was operated in quasi-peak mode. Also, the spectrum analyzer's 6 dB bandwidth was set to 1 MHz (spectrum was examined from 1GHz to 18GHz) and the analyzer was operated in the peak and average mode. There is a test condition apply in this test item, the test procedure description as the following:

EUT transmit only:

Using the LAN port of Notebook computer and software to control the EUT through Ethernet hub. Then making access to the mode of continuous transmission. Three channels is tested, one in the top (CH01), one in the middle (CH06) and the other in bottom (CH11).

With the transmitter operating from a AC source and using the internal of EUT, radiates spurious emissions falling within the restricted bands of 15.209 were measured at operating frequencies corresponding to low, mid and high channels in the 2400 ~ 2483.5 MHz band.

The actual field intensity in decibels referenced to 1 microvolt per meter (dB $\mu$ V/m) is determined by algebraically adding the measured reading in dB $\mu$ V, the antenna factor (dB), and cable loss (dB) at the appropriate frequency.

**For frequency between 30MHz to 1000MHz**

$F_{Ia} \text{ (dB}\mu\text{V/m)} = F_{Ir} \text{ (dB}\mu\text{V)} - \text{Correction Factors}$

$F_{Ia}$  : Actual Field Intensity

$F_{Ir}$  : Reading of the Field Intensity

Correction Factors = Antenna Factor + Cable Loss – Amplifier Gain

**For frequency between 1 GHz to 18 GHz**

$F_{Ia} \text{ (dB}\mu\text{V/m)} = F_{Ir} \text{ (dB}\mu\text{V)} + \text{Correction Factor}$

$F_{Ia}$  : Actual Field Intensity

$F_{Ir}$  : Reading of the Field Intensity

Correction Factors = Antenna Factor + Cable Loss – Amplifier Gain

The setting up procedure is recorded on Appendix A.

**7.2 List of Test Instruments**

<u>Instrument Name</u>	<u>Model No.</u>	<u>Brand</u>	<u>Serial No.</u>	<u>Last time</u>	<u>Next time</u>
EMI Receiver	8546A	H P	3520A00242	06/29/01	06/29/02
RF Filter Section	85460A	H P	3448A00217	06/29/01	06/29/02
Bi-log Antenna	CBL6141A	Schaffner	4206	03/09/01	03/09/02
Switch/Control Unit (> 30MHz)	3488A	HP	N/A	11/20/01	11/20/02
Auto Switch Box (> 30MHz)	ASB-01	TRC	9904-01	11/20/01	11/20/02
Spectrum Analyzer	8564E	HP	US36433002	08/01/01	08/01/02
Microwave Preamplifier	83051A	HP	3232A00347	08/01/01	08/01/02
Horn Antenna	3115	EMCO	9704 – 5178	08/01/01	08/01/02
Anechoic Chamber (cable calibrated together)				05/20/01	05/20/02

### 7.3 Test Instruments Configuration



Front View of the Test Configuration



Rear View of the Test Configuration

**The test configuration for frequency between 1GHz to 18GHz is same as above.**

**7.4 Test Result of Spurious Radiated Emissions**

**EUT's transmit only**

The highest peak values of radiated emissions form the EUT at various antenna heights, antenna polarizations, EUT orientation, etc. The worse case (high gain antenna) are recorded on the following.

**FCC ID** : PB6-00091

**EUT** : TeLLUS WLAN Access Point

Test Conditions:           Testing room : Temperature : 20.2 ° C   Humidity : 63 % RH  
                                   Testing site : Temperature : 23.4 ° C   Humidity : 71 % RH

*Table 5 Radiated Emissions for 30MHz   1GHz [CH 1, Horizontal]*

<i>Radiated Emission</i>				<i>Correction Factors</i>	<i>Corrected Amplitude</i>	<i>FCC Class B ( 3 m )</i>	
<i>Frequency (MHz)</i>	<i>Amplitude (dBmV/m)</i>	<i>Ant. H. (m)</i>	<i>Table ( ° )</i>			<i>Limit (dBmV/m)</i>	<i>Margin (dB)</i>
224.002	7.00	1.00	81	-16.29	23.29	46.00	-22.71
250.071	4.10	1.00	119	-16.17	20.27	46.00	-25.73
264..000	4.43	1.00	87	-16.35	20.78	46.00	-25.22
352.001	5.80	1.00	153	-19.24	25.04	46.00	-20.96
412.616	2.59	1.00	149	-21.28	23.87	46.00	-22.13
747.998	2.49	1.00	32	-28.30	30.79	46.00	-15.21

Note:

1. Margin = Corrected Amplitude – Limit.
2. Peak Amplitude – Correction Factors = Corrected Amplitude

**Table 6 Radiated Emissions for 30MHz 1GHz [CH 1, Vertical]**

Radiated Emission				Correction Factors (dB)	Corrected Amplitude (dBmV/m)	FCC Class B (3 m)	
Frequency (MHz)	Amplitude (dBmV/m)	Ant. H. (m)	Table (°)			Limit (dBmV/m)	Margin (dB)
44.002	7.48	1.00	87	-17.08	24.56	40.00	-15.44
66.635	9.62	1.00	14	-9.79	19.41	40.00	-20.59
224.003	5.95	1.00	44	-15.78	21.73	46.00	-24.27
256.001	3.88	1.00	63	-16.56	20.44	46.00	-25.56
320.002	3.92	1.00	54	-18.71	22.63	46.00	-23.37
412.616	2.75	1.00	112	-20.98	23.73	46.00	-22.27

**Table 7 Open Field Radiated Emissions for 1GHz 18GHz [Channel 1, Horizontal]**

Radiated Emission				Correction Factors (dB)	Corrected Amplitude		FCC Class B (3 m)		
Frequency (GHz)	Amplitude (dBm V/m)	Ant. H. (m)	Table (°)		Peak	Average	Limit		Margin (dB)
							Peak	Ave.	
*11.860	41.39	1.00	83	9.72	51.11	---	74.0	53.9	-22.89
---									

**Table 8 Open Field Radiated Emissions for 1GHz - 18GHz [Channel 1, Vertical]**

<i>Radiated Emission</i>				<i>Correction Factors</i> ( dB )	<i>Corrected Amplitude</i>		<i>FCC Class B ( 3m )</i>		
<i>Frequency</i> (Hz)	<i>Amplitude</i> (dBm V/m)	<i>Ant. H.</i> (m)	<i>Table</i> ( ° )		<i>Peak</i>	<i>Average</i>	<i>Limit</i>		<i>Margin</i> (dB)
							<i>Peak</i>	<i>Ave.</i>	
4.060	44.86	1.00	48	3.91	48.77	---	74.0	53.9	-25.23
10.135	41.55	1.00	56	9.72	51.27	---	74.0	53.9	-22.73
---									

Note:

1. Margin = Corrected - Limit.
2. Peak Amplitude + Correction Factor = Corrected
3. The “ \* “ means restricted bands.
4. As stated in Section 15.35(b), for any frequencies above 1000MHz, radiated limits shown are based upon the use of measurement instrumentation employing an average detector function. As the results of our test, the peak amplitudes are already below the FCC limit. Thus the average amplitudes of the rest are omitted.

**Table 9 Radiated Emissions for 30MHz 1GHz [CH 6, Horizontal]**

<b>Radiated Emission</b>				<b>Correction Factors</b>	<b>Corrected Amplitude</b>	<b>FCC Class B ( 3 m )</b>	
<b>Frequency (MHz)</b>	<b>Amplitude (dBmV/m)</b>	<b>Ant. H. (m)</b>	<b>Table ( ° )</b>			<b>Limit (dBmV/m)</b>	<b>Margin (dB)</b>
224.002	7.14	1.00	86	-16.29	23.43	46.00	-22.57
250.072	5.66	1.00	124	-16.17	21.83	46.00	-24.17
264.000	4.40	1.00	85	-16.35	20.75	46.00	-25.25
352.001	5.96	1.00	4	-19.24	25.20	46.00	-20.80
412.616	2.66	1.00	149	-21.28	23.94	46.00	-22.06
747.997	2.53	1.00	36	-28.30	30.83	46.00	-15.17

**Table 10 Radiated Emissions for 30MHz 1GHz [CH 6, Vertical]**

<b>Radiated Emission</b>				<b>Correction Factors</b>	<b>Corrected Amplitude</b>	<b>FCC Class B ( 3 m )</b>	
<b>Frequency (MHz)</b>	<b>Amplitude (dBmV/m)</b>	<b>Ant. H. (m)</b>	<b>Table ( ° )</b>			<b>Limit (dBmV/m)</b>	<b>Margin (dB)</b>
44.002	7.53	1.00	85	-17.08	24.61	40.00	-15.39
66.566	8.36	1.00	5	-9.80	18.16	40.00	-21.84
224.003	6.19	1.00	39	-15.78	21.97	46.00	-24.03
256.002	4.10	1.00	63	-16.56	20.66	46.00	-25.34
320.002	3.52	1.00	62	-18.71	22.23	46.00	-23.77
412.616	2.75	1.00	109	-20.98	23.73	46.00	-22.27



Table 11 Open Field Radiated Emissions for 1GHz ~ 18GHz [Channel 6, Horizontal]

Radiated Emission				Correction Factors (dB)	Corrected Amplitude		FCC Class B (3m)		Margin (dB)
Frequency (GHz)	Amplitude (dBm V/m)	Ant. H. (m)	Table (°)		Peak	Average	Limit		
							Peak	Ave.	
10.165	42.22	1.00	51	9.72	51.94	---	74.0	53.9	-22.06
---									

Table 12 Open Field Radiated Emissions for 1GHz ~ 18GHz [Channel 6, Vertical]

Radiated Emission				Correction Factors (dB)	Corrected Amplitude		FCC Class B (3m)		Margin (dB)
Frequency (GHz)	Amplitude (dBm V/m)	Ant. H. (m)	Table (°)		Peak	Average	Limit		
							Peak	Ave.	
4.105	43.36	1.00	67	3.91	47.27	---	74.0	53.9	-26.73
---									

**Table 13 Radiated Emissions for 30MHz 1GHz [CH11, Horizontal]**

<b>Radiated Emission</b>				<b>Correction Factors</b>  <b>(dB)</b>	<b>Corrected Amplitude</b>  <b>(dBmV/m)</b>	<b>FCC Class B (3 m)</b>	
<b>Frequency (MHz)</b>	<b>Amplitude (dBmV/m)</b>	<b>Ant. H. (m)</b>	<b>Table ( ° )</b>			<b>Limit (dBmV/m)</b>	<b>Margin (dB)</b>
224.002	6.74	1.00	91	-16.29	23.03	46.00	-22.97
250.071	5.86	1.00	127	-16.17	22.03	46.00	-23.97
264.001	4.43	1.00	83	-16.35	20.78	46.00	-25.22
352.000	5.87	1.00	4	-19.24	25.11	46.00	-20.89
412.616	2.61	1.00	149	-21.28	23.89	46.00	-22.11
747.997	2.56	1.00	33	-28.30	30.86	46.00	-15.14

**Table 14 Radiated Emissions for 30MHz 1GHz [CH 11, Vertical]**

<b>Radiated Emission</b>				<b>Correction Factors</b>  <b>(dB)</b>	<b>Corrected Amplitude</b>  <b>(dBmV/m)</b>	<b>FCC Class B (3 m)</b>	
<b>Frequency (MHz)</b>	<b>Amplitude (dBmV/m)</b>	<b>Ant. H. (m)</b>	<b>Table ( ° )</b>			<b>Limit (dBmV/m)</b>	<b>Margin (dB)</b>
44.002	7.48	1.00	87	-17.08	24.56	40.00	-15.44
66.635	9.62	1.00	14	-9.79	19.41	40.00	-20.59
224.003	5.95	1.00	44	-15.78	21.73	46.00	-24.27
256.001	3.88	1.00	63	-16.56	20.44	46.00	-25.56
320.002	3.92	1.00	54	-18.71	22.63	46.00	-23.37
412.616	2.75	1.00	112	-20.98	23.73	46.00	-22.27

Table 15 Open Field Radiated Emissions for 1Hz 18Hz [Channel 11, Horizontal]

Radiated Emission				Correction Factors (dB)	Corrected Amplitude		FCC Class B (3m)		
Frequency (Hz)	Amplitude (dBm V/m)	Ant. H. (m)	Table (°)		Peak	Average	Limit		Margin (dB)
							Peak	Ave.	
4.180	40.20	1.00	94	3.91	44.11	---	74.0	53.9	-29.89
*11.860	41.89	1.00	36	9.72	51.61	---	74.0	53.9	-22.39
---									

Table 16 Open Field Radiated Emissions for 1GHz 18GHz [Channel 11, Vertical]

Radiated Emission				Correction Factors (dB)	Corrected Amplitude		FCC Class B (3m)		
Frequency (Hz)	Amplitude (dBm V/m)	Ant. H. (m)	Table (°)		Peak	Average	Limit		Margin (dB)
							Peak	Ave.	
4.180	45.70	1.00	56	3.91	49.61	---	74.0	53.9	-24.39
6.280	37.55	1.00	23	9.72	47.27	---	74.0	53.9	-26.73
*7.420	40.22	1.00	7	9.72	49.94	---	74.0	53.9	-24.06
11.860	41.05	1.00	96	9.72	50.77	---	74.0	53.9	-23.23
---									

### **7.5 Test Result of Bandedge**

If any 100 kHz bandwidth outside these frequency bands, the radio frequency power that is produced by the modulation products of the spreading sequence, the information sequence and the carrier frequency shall be either at least 20 dB below that in any 100 kHz bandwidth within the band that contains the highest level of the desired power or shall not exceed the general levels specified in § 15.209(a), whichever results in the lesser attenuation.

Channel 01



#This is the hard copy of our measurement on *channel 1 bandedge*. The spectrum plot extended to the 2390MHz (restriction band) is below 10dBuV. By involving our correction factor 35.6dB(1/m), the field strength should be also below 45.6dBuV/m. According to the Sect.15.205, The EUT comply with all the spurious emission below 54dbuV/m.

Channel 11

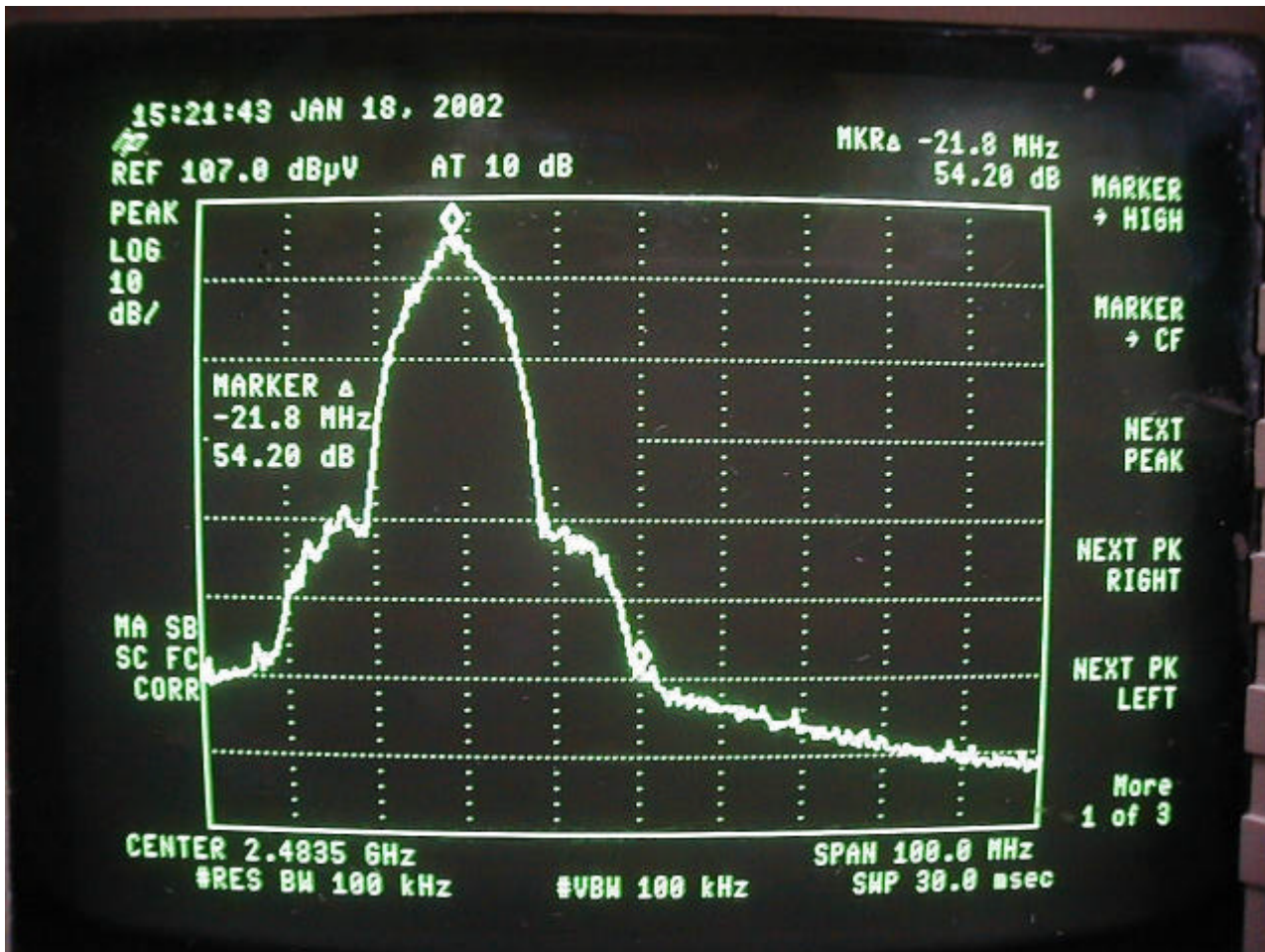

#This is the hard copy of our measurement on *channel 11 bandedge*. The spectrum plot extended to the 2483.5MHz (restriction band) is below 10dBuV. By involving our correction factor 35.6dB(1/m), the field strength should be also below 45.6dBuV/m. According to the Sect.15.205, The EUT comply with all the the spurious emission below 54dbuV/m.

## VIII. **Section 15.247(d): Power Spectral Density**

### **8.1 Test Condition & Setup**

The tests below are running with the EUT transmitter set at high power in TDD mode .A LAN port from a notebook computer connect to the EUT. The EUT is needed to force selection of output power level and channel number. While testing, the EUT was set to transmit continuously and to be tested by the contact manner with the spectrum analyzer.

The attachments below show our observation.

**8.2 Test Instruments Configuration**

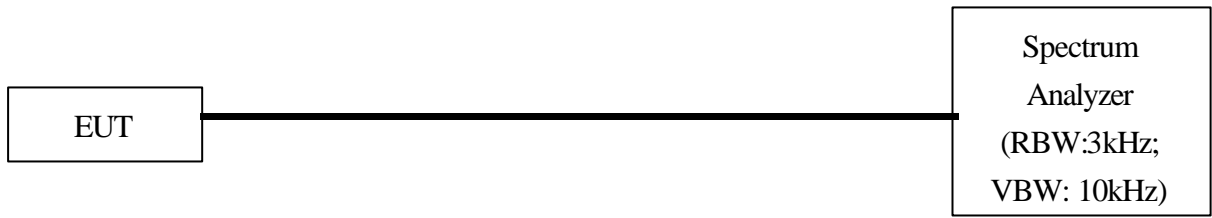

Test Configuration of Power Spectral Density

*P.S.: Notebook computer to control the EUT at maximal power output and channel Number and set antenna kit*

**8.3 List of Test Instruments**

Instrument Name	Model No.	Brand	Serial No.	Last time	Next time
Spectrum Analyzer	8592A	H P	3003AD1401	01/02/02	01/01/03



**8.4 Test Result of Power spectral density**

The following table shows a summary of the highest power out of UT.

**FCC ID** : PB6-00091

<i>Channel</i>	<i>Frequency (GHz)</i>	<i>Ppr (dBm)</i>	<i>CF (dB)</i>	<i>Ppq (dBm)</i>	<i>Limit (dB)</i>	<i>Margin (dB)</i>
CH 01	2.411	-17.62	1.80	-15.82	8.00	-23.82
CH 06	2.438	-16.79	1.85	-14.94	8.00	-22.94
CH 11	2.462	-17.30	1.93	-15.37	8.00	-23.37

Note:

1. The attachment follow by this page and there is no page number.
2. Ppr: spectrum read power density (using peak search mode), CF: correct factor, Ppq: actual peak power density in the spread spectrum band.
3. Ppq = Ppr + CF
4. Effective Radiation Power (E.R.P.) = (E d)<sup>2</sup> / 30G

"E" is the measured maximum field strength in V/m utilizing the maximum hold mode RBW (3KHz)

"G" is the numeric gain of the transmitting antenna over an isotropic radiator (1.00).

"d" is the distance in meters from which the field strength was measured (3M).

Example: the Max Radiation Emission = 39.64 + (35.60) = 87.33 dBμV/m

$$10^{(87.33/20)} \times 10^{-6} = 0.011028 \text{ V}$$

$$\text{E.R.P.} = (0.023254 \times 3)^2 / 30 = 0.162226 \text{ mW}$$

$$= 10 \times \log (0.162226 \text{ mW/1mW})$$

$$= -7.90 \text{ dBm}$$

Channel 01

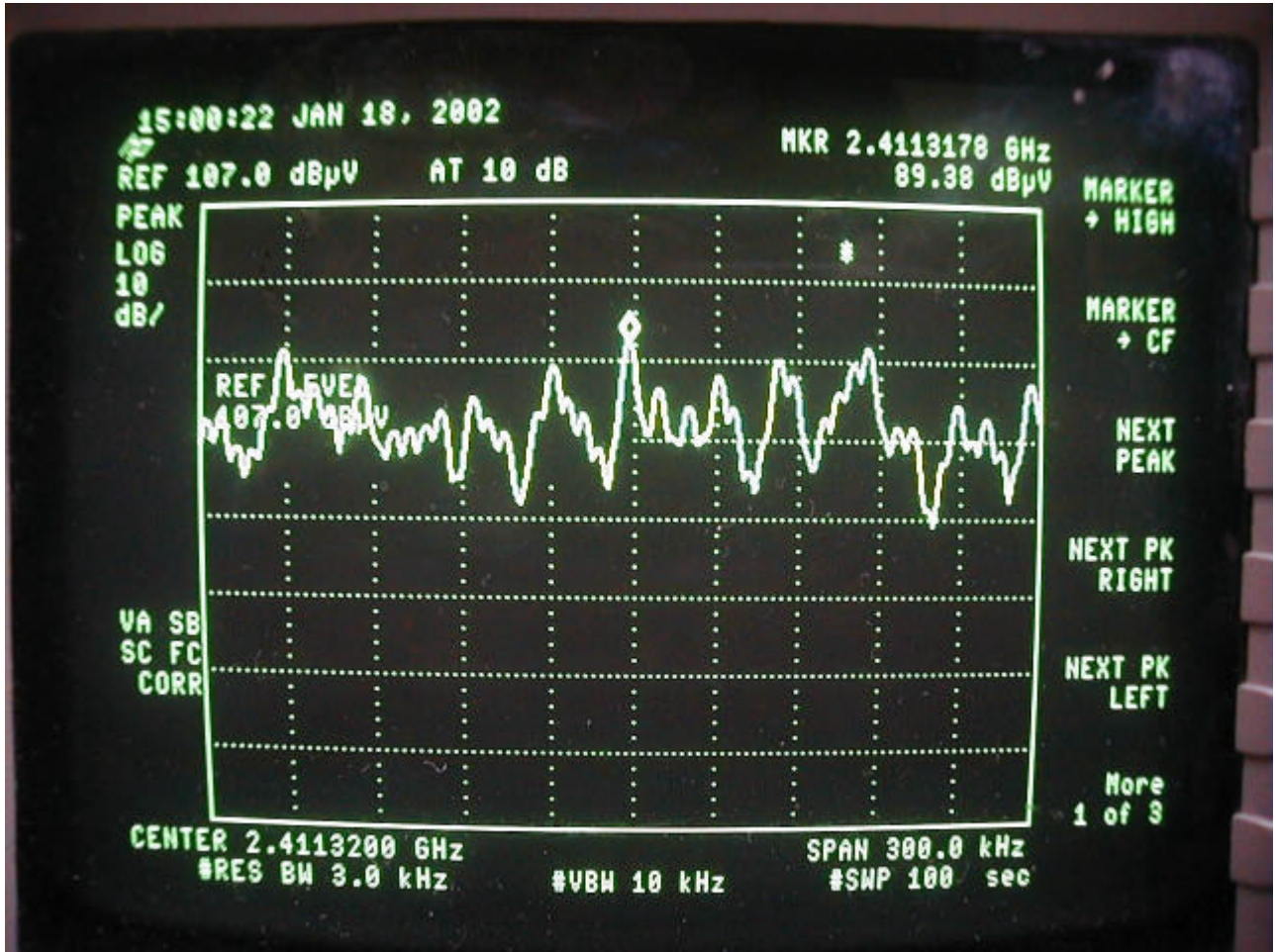

Channel 06

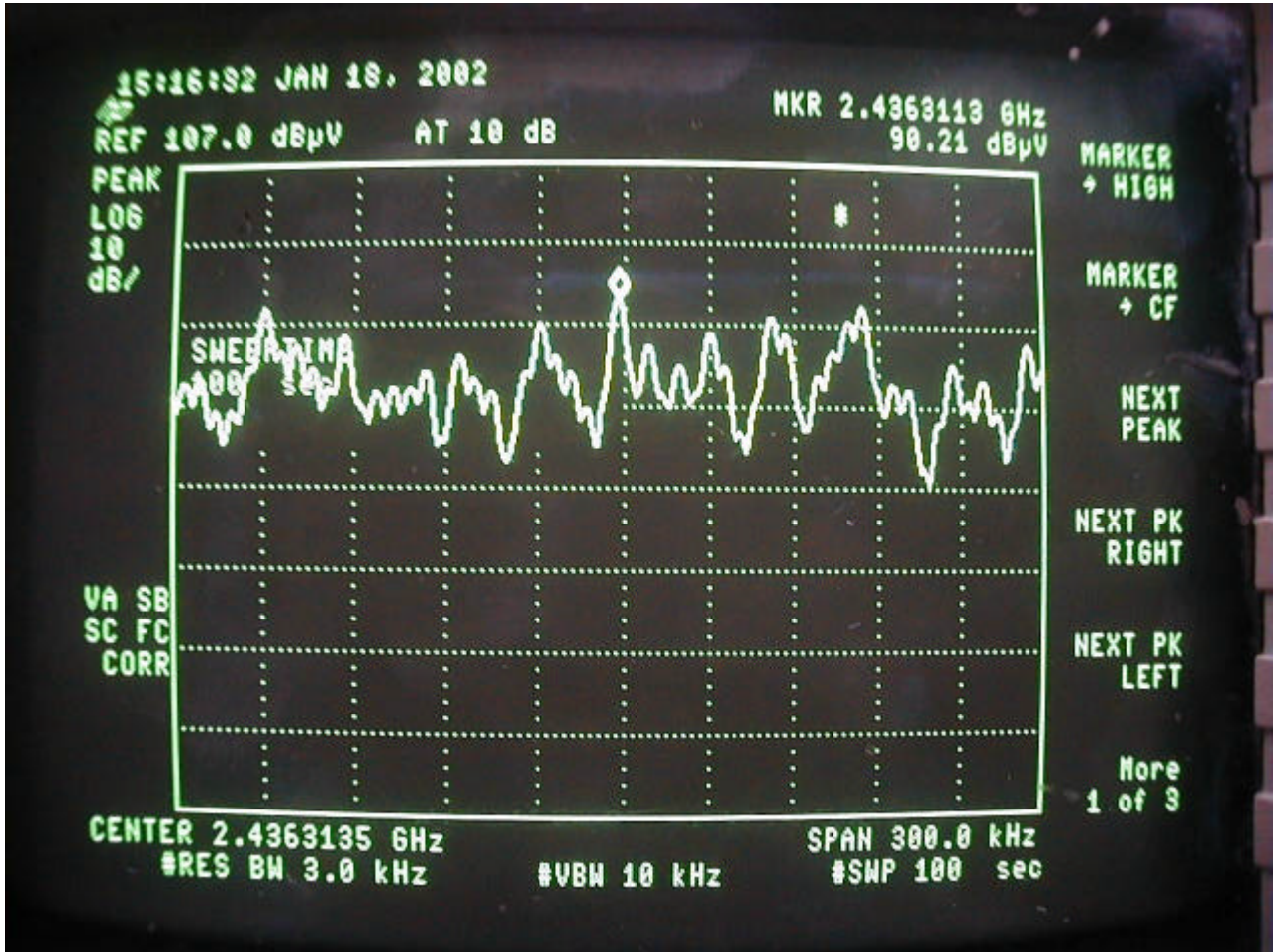

Channel 11

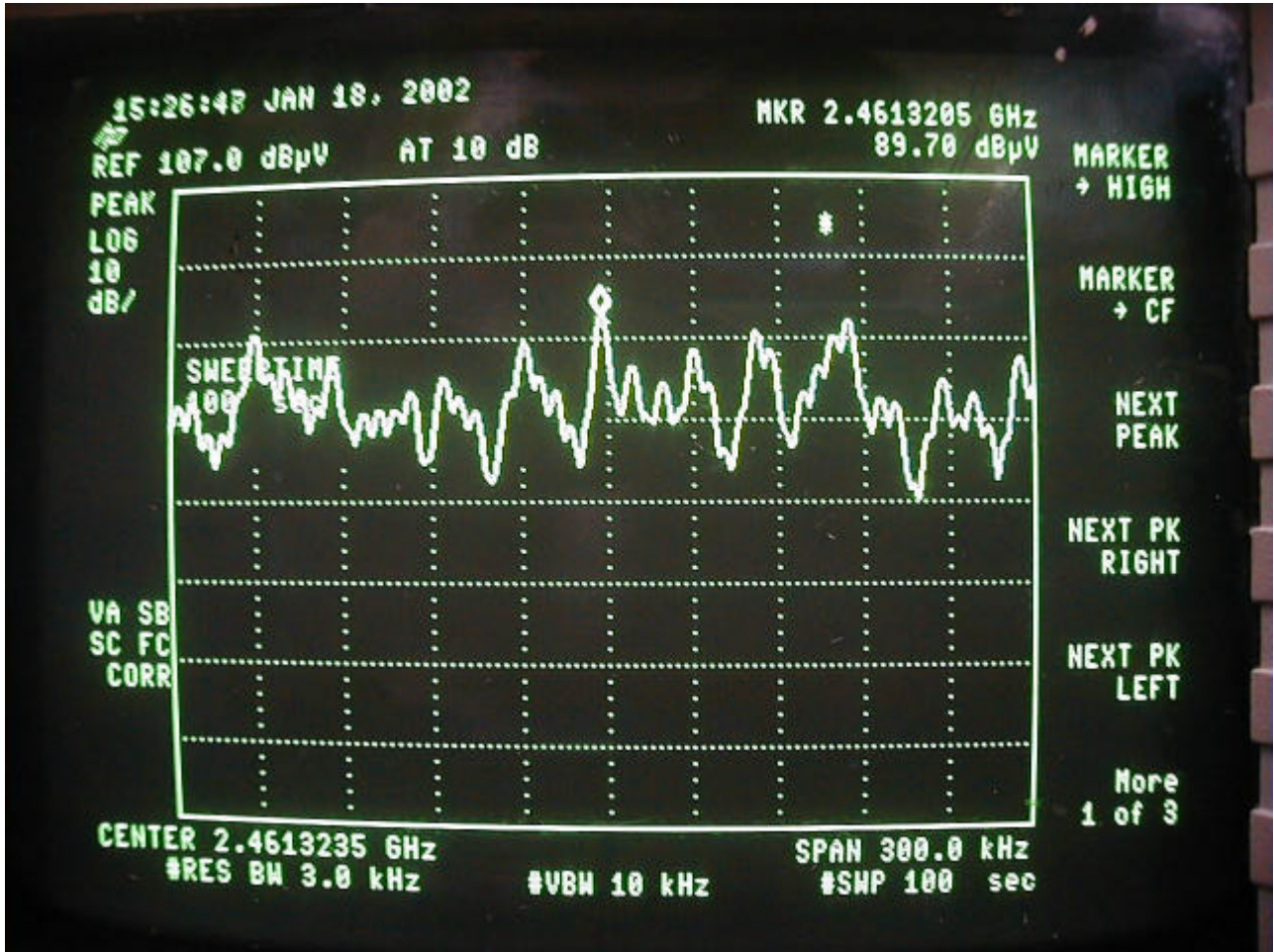

## *Appendix A*

### **Setting up Procedure**

1. The UTP port EUT connected to an Ethernet HUB, which connect to LAN port of notebook computer through RJ45 cable. Using the located remotely LAN to LAN port of notebook computer and software to control the EUT
2. Use the software that is given by the customer and operated in the windows to control the EUT's continuous transmission and set antenna kit.
3. Then making access to the mode of continuous transmission and set testing channel.

## *Appendix B*

### *Antenna Specificaiton*