



*EMC Test Report
Application for Grant of Equipment Authorization
pursuant to
Industry Canada RSS-Gen Issue 2 / RSS 210 Issue 7
FCC Part 15 Subpart C*

Model: iTrip AutoPilot 2009 (P2107)

IC CERTIFICATION #: 6384A-2107TRIP
FCC ID: PAV2107

APPLICANT: Griffin Technology
1930 Air Lane Drive
Nashville, TN 37210

TEST SITE(S): Elliott Laboratories
41039 Boyce Road.
Fremont, CA. 94538-2435

IC SITE REGISTRATION #: 2845B-3; 2845B-4

REPORT DATE: February 26, 2010

FINAL TEST DATES: November 20, 2009

AUTHORIZED SIGNATORY:

A handwritten signature in blue ink, appearing to read "Mark E. Hill", written over a horizontal line.

Mark E. Hill
Staff Engineer
Elliott Laboratories



Testing Cert #2016-01

Elliott Laboratories is accredited by the A2LA, certificate number 2016-01, to perform the test(s) listed in this report, except where noted otherwise. This report shall not be reproduced, except in its entirety, without the written approval of Elliott Laboratories

REVISION HISTORY

Rev#	Date	Comments	Modified By
-	February 26, 2010	First release	

TABLE OF CONTENTS

COVER PAGE	1
REVISION HISTORY	2
TABLE OF CONTENTS	3
SCOPE	4
OBJECTIVE	4
STATEMENT OF COMPLIANCE	5
DEVIATIONS FROM THE STANDARDS	5
TEST RESULTS SUMMARY	6
DEVICES OPERATING IN THE 88-108 MHZ FM BAND.....	6
GENERAL REQUIREMENTS APPLICABLE TO ALL BANDS	6
MEASUREMENT UNCERTAINTIES.....	7
EQUIPMENT UNDER TEST (EUT) DETAILS	8
GENERAL.....	8
ANTENNA SYSTEM	8
ENCLOSURE.....	8
MODIFICATIONS.....	8
SUPPORT EQUIPMENT.....	8
EUT INTERFACE PORTS	9
EUT OPERATION	9
TEST SITE	10
GENERAL INFORMATION.....	10
RADIATED EMISSIONS CONSIDERATIONS	10
MEASUREMENT INSTRUMENTATION	11
RECEIVER SYSTEM	11
INSTRUMENT CONTROL COMPUTER	11
FILTERS/ATTENUATORS	11
ANTENNAS.....	12
ANTENNA MAST AND EQUIPMENT TURNTABLE	12
INSTRUMENT CALIBRATION.....	12
TEST PROCEDURES	12
EUT AND CABLE PLACEMENT	12
RADIATED EMISSIONS	13
BANDWIDTH MEASUREMENTS	15
SPECIFICATION LIMITS AND SAMPLE CALCULATIONS	16
GENERAL TRANSMITTER RADIATED EMISSIONS SPECIFICATION LIMITS	16
RADIATED FUNDAMENTAL & SPURIOUS EMISSIONS SPECIFICATION LIMITS – 15.239 AND RSS 210 A2.9	16
SAMPLE CALCULATIONS - CONDUCTED EMISSIONS	17
SAMPLE CALCULATIONS - RADIATED EMISSIONS.....	17
SAMPLE CALCULATIONS - FIELD STRENGTH TO EIRP CONVERSION.....	18
APPENDIX A TEST EQUIPMENT CALIBRATION DATA	1
APPENDIX B TEST DATA	2

SCOPE

An electromagnetic emissions test has been performed on the Griffin Technology model iTrip AutoPilot 2009 (P2107), pursuant to the following rules:

Industry Canada RSS-Gen Issue 2
RSS 210 Issue 7 "Low-power Licence-exempt Radiocommunication Devices (All Frequency Bands): Category I Equipment"
FCC Part 15 Subpart C

Conducted and radiated emissions data has been collected, reduced, and analyzed within this report in accordance with measurement guidelines set forth in the following reference standards and as outlined in Elliott Laboratories test procedures:

ANSI C63.4:2003

The intentional radiator above has been tested in a simulated typical installation to demonstrate compliance with the relevant Industry Canada performance and procedural standards.

Final system data was gathered in a mode that tended to maximize emissions by varying orientation of EUT, orientation of power and I/O cabling, antenna search height, and antenna polarization.

Every practical effort was made to perform an impartial test using appropriate test equipment of known calibration. All pertinent factors have been applied to reach the determination of compliance.

OBJECTIVE

The primary objective of the manufacturer is compliance with the regulations outlined in the previous section.

Prior to marketing in Canada, Class I transmitters, receivers and transceivers require certification. Class II devices are required to meet the appropriate technical requirements but are exempt from certification requirements.

Certification is a procedure where the manufacturer submits test data and technical information to a certification body and receives a certificate or grant of equipment authorization upon successful completion of the certification body's review of the submitted documents. Once the equipment authorization has been obtained, the label indicating compliance must be attached to all identical units, which are subsequently manufactured.

Maintenance of compliance is the responsibility of the manufacturer. Any modification of the product which may result in increased emissions should be checked to ensure compliance has been maintained (i.e., printed circuit board layout changes, different line filter, different power supply, harnessing or I/O cable changes, etc.).

STATEMENT OF COMPLIANCE

The tested sample of Griffin Technology model iTrip AutoPilot 2009 (P2107) complied with the requirements of the following regulations:

Industry Canada RSS-Gen Issue 2
RSS 210 Issue 7 “Low-power Licence-exempt Radiocommunication Devices (All Frequency Bands): Category I Equipment”
FCC Part 15 Subpart C

Maintenance of compliance is the responsibility of the manufacturer. Any modifications to the product should be assessed to determine their potential impact on the compliance status of the device with respect to the standards detailed in this test report.

The test results recorded herein are based on a single type test of Griffin Technology model iTrip AutoPilot 2009 (P2107) and therefore apply only to the tested sample. The sample was selected and prepared by Michael O'Connor of Griffin Technology.

DEVIATIONS FROM THE STANDARDS

No deviations were made from the published requirements listed in the scope of this report.

TEST RESULTS SUMMARY**DEVICES OPERATING IN THE 88-108 MHz FM BAND**

FCC Rule Part	RSS Rule Part	Description	Measured Value / Comments	Limit / Requirement	Result
15.239 (a)	RSS 210 A2.8	Bandwidth and operating range	151 kHz	Bandwidth less than 200kHz contained in the 88 – 108 MHz band	
15.239 (b)	RSS 210 A2.8 (1)	Fundamental Field Strength	47.5dB μ V/m @ 98.100MHz (-0.5dB)	250uV/m at 3m	Complies
15.239 (c) / 15.209	RSS 210 Table 2	Radiated Spurious Emissions, 30 – 540 MHz	39.4dB μ V/m @ 30.855MHz (-0.6dB)	Refer to table in limits section	Complies

GENERAL REQUIREMENTS APPLICABLE TO ALL BANDS

FCC Rule Part	RSS Rule part	Description	Measured Value / Comments	Limit / Requirement	Result (margin)
15.203	-	RF Connector	The antenna is integral to the device.	-	Complies
15.109	RSS GEN 7.2.3 Table 1	Receiver spurious emissions	39.4dB μ V/m @ 30.855MHz (-0.6dB)	Refer to table in limits section	Complies – Note 2
15.207	RSS GEN Table 2	AC Conducted Emissions	-	-	N/A – Note 1
15.247 (b) (5) / 15.407 (f)	RSS 102	RF Exposure Requirements	RSS 102 declaration and User Manual Statements	Refer to OET 65, FCC Part 1 and RSS 102	Complies
-	RSP 100 RSS GEN 4.4.1	99% Bandwidth	138 kHz	Information only	N/A

Note 1 - Note 1- The EUT is powered from a 12VDC automotive cigarette lighter adapter. The P2107 does pass power thru to the iPod for charging of the iPod.

Note 2 – Preliminary testing showed that the emissions during receive operation were equal to or less than the emissions during the transmit operation.

MEASUREMENT UNCERTAINTIES

ISO/IEC 17025 requires that an estimate of the measurement uncertainties associated with the emissions test results be included in the report. The measurement uncertainties given below are based on a 95% confidence level and were calculated in accordance with UKAS document LAB 34.

Measurement Type	Frequency Range (MHz)	Calculated Uncertainty (dB)
Conducted Emissions	0.15 to 30	± 2.4
Radiated Emissions	0.015 to 30	± 3.0
Radiated Emissions	30 to 1000	± 3.6
Radiated Emissions	1000 to 40000	± 6.0

EQUIPMENT UNDER TEST (EUT) DETAILS**GENERAL**

The Griffin Technology model iTrip AutoPilot 2009 (P2107) is a portable FM transmitter that is designed to transmit audio information from an iPod. For this testing, the EUT was placed on a table-top. The EUT is powered via the 12V automobile power outlet.

The sample was received on October 27, 2009 and tested on November 18 and November 20, 2009. The EUT consisted of the following component(s):

Company	Model	Description	Serial Number	FCC ID
Griffin	iTrip AutoPilot 2009 (P2107)	FM Transmitter	N/A	PAV2107

ANTENNA SYSTEM

The antenna system used with the Griffin Technology model iTrip AutoPilot 2009 (P2107) is integral to the device.

ENCLOSURE

The EUT enclosure is primarily constructed of plastic. It measures approximately 6cm wide by 3cm deep by 1cm high.

MODIFICATIONS

No modifications were made to the EUT during the time the product was at Elliott.

SUPPORT EQUIPMENT

The following equipment was used as support equipment for testing:

Company	Model	Description	Serial Number	FCC ID
Apple	iPod NANO	MP3 Player	-	N/A
Agilent	E3610A	DC Power Supply	-	-

No remote support equipment was used during testing.

EUT INTERFACE PORTS

The I/O cabling configuration during testing was as follows:

Port	Connected To	Description	Cable(s)	
			Shielded or Unshielded	Length(m)
iPod port	iPod	-	-	-
DC	DC Supply	2Wire	Unshielded	1.0

EUT OPERATION

During emissions testing the EUT was configured to continuously transmit a typical audio file. The audio file was comprised of instrumental music. The user controls were adjusted during preliminary testing to show that they have no influence on the final results.

TEST SITE**GENERAL INFORMATION**

Final test measurements were taken on November 20, 2009 at the test sites listed below. Pursuant to section 2.948 of the FCC's Rules and section 3.3 of RSP-100, construction, calibration, and equipment data has been filed with the Commission and with industry Canada.

Site	Registration Numbers		Location
	FCC	Canada	
Chamber 4	211948	2845B-4	41039 Boyce Road Fremont, CA 94538-2435

ANSI C63.4:2003 recommends that ambient noise at the test site be at least 6 dB below the allowable limits. Ambient levels are below this requirement. The test site(s) contain separate areas for radiated and conducted emissions testing. Considerable engineering effort has been expended to ensure that the facilities conform to all pertinent requirements of ANSI C63.4:2003.

RADIATED EMISSIONS CONSIDERATIONS

The FCC has determined that radiation measurements made in a shielded enclosure are not suitable for determining levels of radiated emissions. Radiated measurements are performed in an open field environment or in a semi-anechoic chamber. The test sites are maintained free of conductive objects within the CISPR defined elliptical area incorporated in ANSI C63.4:2003 guidelines and meet the Normalized Site Attenuation (NSA) requirements of ANSI C63.4:2003.

MEASUREMENT INSTRUMENTATION

RECEIVER SYSTEM

An EMI receiver as specified in CISPR 16-1-1 is used for emissions measurements. The receivers used can measure over the frequency range of 9 kHz up to 2000 MHz. These receivers allow both ease of measurement and high accuracy to be achieved. The receivers have Peak, Average, and CISPR (Quasi-peak) detectors built into their design so no external adapters are necessary. The receiver automatically sets the required bandwidth for the CISPR detector used during measurements. If the repetition frequency of the signal being measured is below 20Hz, peak measurements are made in lieu of Quasi-Peak measurements.

For measurements above the frequency range of the receivers, a spectrum analyzer is utilized because it provides visibility of the entire spectrum along with the precision and versatility required to support engineering analysis. Average measurements above 1000MHz are performed on the spectrum analyzer using the linear-average method with a resolution bandwidth of 1 MHz and a video bandwidth of 10 Hz, unless the signal is pulsed in which case the average (or video) bandwidth of the measuring instrument is reduced to onset of pulse desensitization and then increased.

INSTRUMENT CONTROL COMPUTER

The receivers utilize either a Rohde & Schwarz EZM Spectrum Monitor/Controller or contain an internal Spectrum Monitor/Controller to view and convert the receiver measurements to the field strength at an antenna or voltage developed at the LISN measurement port, which is then compared directly with the appropriate specification limit. This provides faster, more accurate readings by performing the conversions described under Sample Calculations within the Test Procedures section of this report. Results are printed in a graphic and/or tabular format, as appropriate. A personal computer is used to record all measurements made with the receivers.

The Spectrum Monitor provides a visual display of the signal being measured. In addition, the controller or a personal computer run automated data collection programs which control the receivers. This provides added accuracy since all site correction factors, such as cable loss and antenna factors are added automatically.

FILTERS/ATTENUATORS

External filters and precision attenuators are often connected between the receiving antenna or LISN and the receiver. This eliminates saturation effects and non-linear operation due to high amplitude transient events.

ANTENNAS

A loop antenna is used below 30 MHz. For the measurement range 30 MHz to 1000 MHz either a combination of a biconical antenna and a log periodic or a bi-log antenna is used. Above 1000 MHz, horn antennas are used. The antenna calibration factors to convert the received voltage to an electric field strength are included with appropriate cable loss and amplifier gain factors to determine an overall site factor, which is then programmed into the test receivers or incorporated into the test software.

ANTENNA MAST AND EQUIPMENT TURNTABLE

The antennas used to measure the radiated electric field strength are mounted on a non-conductive antenna mast equipped with a motor-drive to vary the antenna height. Measurements below 30 MHz are made with the loop antenna at a fixed height of 1m above the ground plane.

ANSI C63.4:2003 specifies that the test height above ground for table mounted devices shall be 80 centimeters. Floor mounted equipment shall be placed on the ground plane if the device is normally used on a conductive floor or separated from the ground plane by insulating material from 3 to 12 mm if the device is normally used on a non-conductive floor. During radiated measurements, the EUT is positioned on a motorized turntable in conformance with this requirement.

INSTRUMENT CALIBRATION

All test equipment is regularly checked to ensure that performance is maintained in accordance with the manufacturer's specifications. All antennas are calibrated at regular intervals with respect to tuned half-wave dipoles. An exhibit of this report contains the list of test equipment used and calibration information.

TEST PROCEDURES

EUT AND CABLE PLACEMENT

The regulations require that interconnecting cables be connected to the available ports of the unit and that the placement of the unit and the attached cables simulate the worst case orientation that can be expected from a typical installation, so far as practicable. To this end, the position of the unit and associated cabling is varied within the guidelines of ANSI C63.4:2003, and the worst-case orientation is used for final measurements.

RADIATED EMISSIONS

A preliminary scan of the radiated emissions is performed in which all significant EUT frequencies are identified with the system in a nominal configuration. At least two scans are performed, one scan for each antenna polarization (horizontal and vertical; loop parallel and perpendicular to the EUT). During the preliminary scans, the EUT is rotated through 360°, the antenna height is varied (for measurements above 30 MHz) and cable positions are varied to determine the highest emission relative to the limit. Preliminary scans may be performed in a fully anechoic chamber for the purposes of identifying the frequencies of the highest emissions from the EUT.

A speaker is provided in the receiver to aid in discriminating between EUT and ambient emissions. Other methods used during the preliminary scan for EUT emissions involve scanning with near field magnetic loops, monitoring I/O cables with RF current clamps, and cycling power to the EUT.

Final maximization is a phase in which the highest amplitude emissions identified in the spectral search are viewed while the EUT azimuth angle is varied from 0 to 360 degrees relative to the receiving antenna. The azimuth, which results in the highest emission is then maintained while varying the antenna height from one to four meters (for measurements above 30 MHz, measurements below 30 MHz are made with the loop antenna at a fixed height of 1m). The result is the identification of the highest amplitude for each of the highest peaks. Each recorded level is corrected in the receiver using appropriate factors for cables, connectors, antennas, and preamplifier gain.

When testing above 18 GHz, the receive antenna is located at 1 meter from the EUT and the antenna height is restricted to a maximum of 2.5 meters.

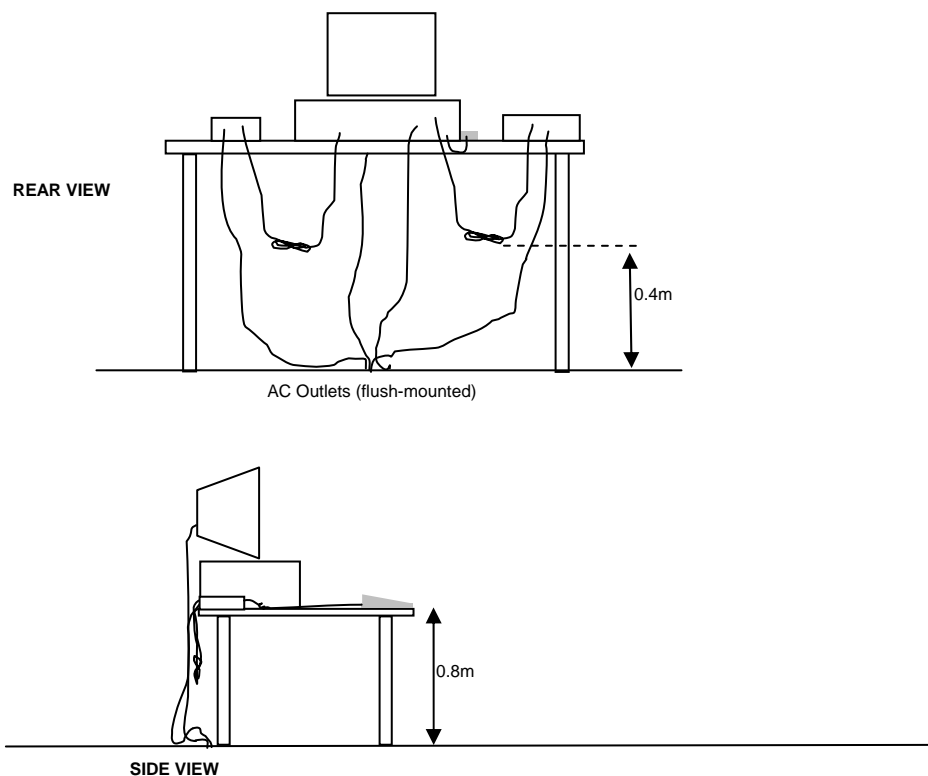

Typical Test Configuration for Radiated Field Strength Measurements

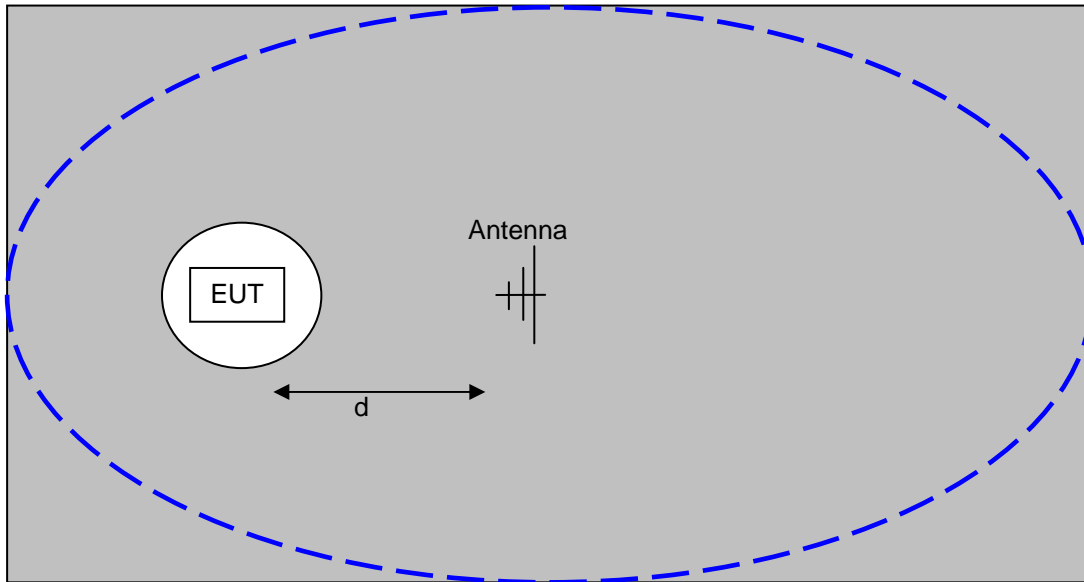

The ground plane extends beyond the ellipse defined in CISPR 16 / CISPR 22 / ANSI C63.4 and is large enough to accommodate test distances (d) of 3m and 10m. Refer to the test data tables for the actual measurement distance.

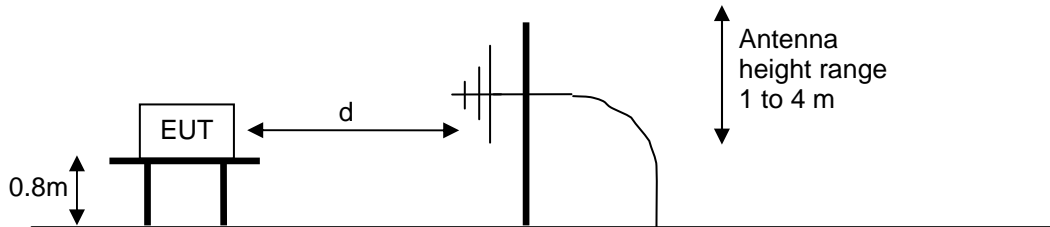

Test Configuration for Radiated Field Strength Measurements
OATS- Plan and Side Views

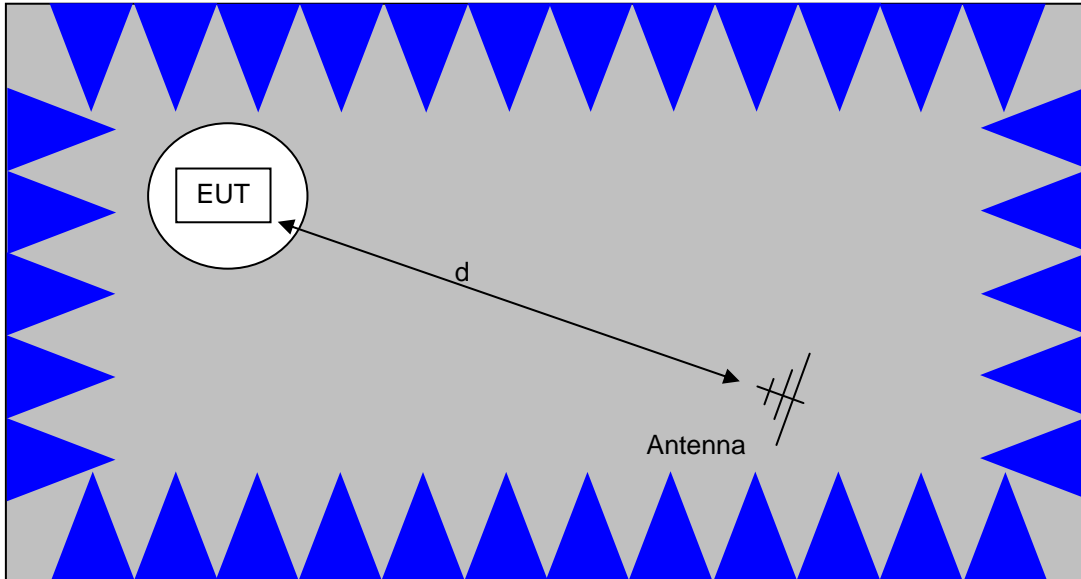

The anechoic materials on the walls and ceiling ensure compliance with the normalized site attenuation requirements of CISPR 16 / CISPR 22 / ANSI C63.4 for an alternate test site at the measurement distances used.

Floor-standing equipment is placed on the floor with insulating supports between the unit and the ground plane.

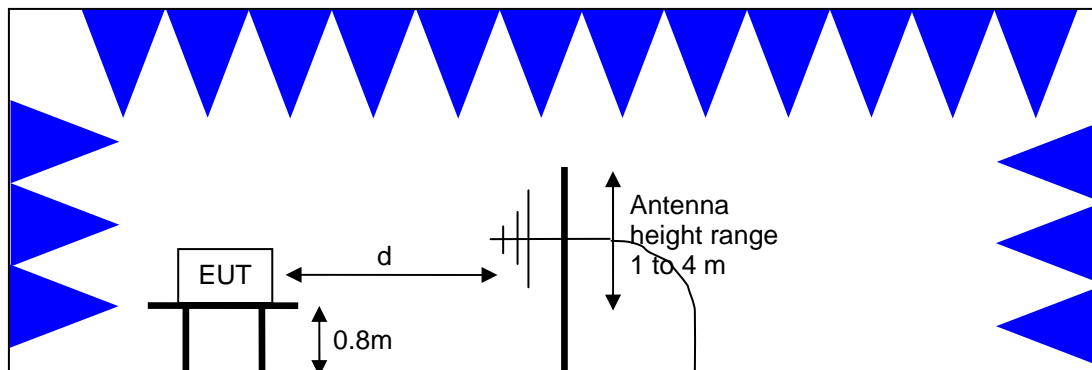

Test Configuration for Radiated Field Strength Measurements
Semi-Anechoic Chamber, Plan and Side Views

BANDWIDTH MEASUREMENTS

The 6dB, 20dB and/or 26dB signal bandwidth is measured in using the bandwidths recommended by ANSI C63.4. When required, the 99% bandwidth is measured using the methods detailed in RSS GEN.

SPECIFICATION LIMITS AND SAMPLE CALCULATIONS

The limits for conducted emissions are given in units of microvolts, and the limits for radiated emissions are given in units of microvolts per meter at a specified test distance. Data is measured in the logarithmic form of decibels relative to one microvolt, or dB microvolts (dBuV). For radiated emissions, the measured data is converted to the field strength at the antenna in dB microvolts per meter (dBuV/m). The results are then converted to the linear forms of uV and uV/m for comparison to published specifications.

For reference, converting the specification limits from linear to decibel form is accomplished by taking the base ten logarithm, then multiplying by 20. These limits in both linear and logarithmic form are as follows:

GENERAL TRANSMITTER RADIATED EMISSIONS SPECIFICATION LIMITS

The table below shows the limits for the spurious emissions from transmitters that fall in restricted bands¹ (with the exception of transmitters operating under FCC Part 15 Subpart D and RSS 210 Annex 9), the limits for all emissions from a low power device operating under the general rules of RSS 310 (tables 3 and 4), RSS 210 (table 2) and FCC Part 15 Subpart C section 15.209.

Frequency Range (MHz)	Limit (uV/m)	Limit (dBuV/m @ 3m)
0.009-0.490	2400/F _{KHz} @ 300m	67.6-20*log ₁₀ (F _{KHz}) @ 300m
0.490-1.705	24000/F _{KHz} @ 30m	87.6-20*log ₁₀ (F _{KHz}) @ 30m
1.705 to 30	30 @ 30m	29.5 @ 30m
30 to 88	100 @ 3m	40 @ 3m
88 to 216	150 @ 3m	43.5 @ 3m
216 to 960	200 @ 3m	46.0 @ 3m
Above 960	500 @ 3m	54.0 @ 3m

RADIATED FUNDAMENTAL & SPURIOUS EMISSIONS SPECIFICATION LIMITS – 15.239 and RSS 210 A2.9

Frequency Range (MHz)	Limit for Fundamental @ 3m	Limit for all signals outside of the occupied bandwidth @ 3m
88 - 108	250 uV/m 48 dBuV/m	General limits apply
The occupied bandwidth is limited to 200kHz. RSS 210 allows the fundamental field strength to be 1000uV/m at 30m at these specific frequencies 88.1; 88.3; 88.5; 107.7; 107.9 MHz is 1000uV/m at 30m for FM devices.		

¹ The restricted bands are detailed in FCC 15.203, RSS 210 Table 1 and RSS 310 Table 2

SAMPLE CALCULATIONS - CONDUCTED EMISSIONS

Receiver readings are compared directly to the conducted emissions specification limit (decibel form) as follows:

$$R_r - S = M$$

where:

R_r = Receiver Reading in dBuV

S = Specification Limit in dBuV

M = Margin to Specification in +/- dB

SAMPLE CALCULATIONS - RADIATED EMISSIONS

Receiver readings are compared directly to the specification limit (decibel form). The receiver internally corrects for cable loss, preamplifier gain, and antenna factor. The calculations are in the reverse direction of the actual signal flow, thus cable loss is added and the amplifier gain is subtracted. The Antenna Factor converts the voltage at the antenna coaxial connector to the field strength at the antenna elements.

A distance factor, when used for electric field measurements above 30MHz, is calculated by using the following formula:

$$F_d = 20 * \text{LOG}_{10} (D_m/D_s)$$

where:

F_d = Distance Factor in dB

D_m = Measurement Distance in meters

D_s = Specification Distance in meters

For electric field measurements below 30MHz the extrapolation factor is either determined by making measurements at multiple distances or a theoretical value is calculated using the formula:

$$F_d = 40 * \text{LOG}_{10} (D_m/D_s)$$

Measurement Distance is the distance at which the measurements were taken and Specification Distance is the distance at which the specification limits are based. The antenna factor converts the voltage at the antenna coaxial connector to the field strength at the antenna elements.

The margin of a given emission peak relative to the limit is calculated as follows:

$$R_c = R_r + F_d$$

and

$$M = R_c - L_s$$

where:

$$R_r = \text{Receiver Reading in dBuV/m}$$

$$F_d = \text{Distance Factor in dB}$$

$$R_c = \text{Corrected Reading in dBuV/m}$$

$$L_s = \text{Specification Limit in dBuV/m}$$

$$M = \text{Margin in dB Relative to Spec}$$

SAMPLE CALCULATIONS - FIELD STRENGTH TO EIRP CONVERSION

Where the radiated electric field strength is expressed in terms of the equivalent isotropic radiated power (eirp), or where a field strength measurement of output power is made in lieu of a direct measurement, the following formula is used to convert between eirp and field strength at a distance of 3m from the equipment under test:

$$E = \frac{1000000 \sqrt{30 P}}{3} \quad \text{microvolts per meter}$$

where P is the eirp (Watts)

Appendix A Test Equipment Calibration Data

Radiated Emissions, 30 - 1,000 MHz, 20-Nov-09**Engineer: Rafael Varelas**

<u>Manufacturer</u>	<u>Description</u>	<u>Model #</u>	<u>Asset #</u>	<u>Cal Due</u>
Com-Power Corp.	Preamplifier, 30-1000 MHz	PA-103	1543	02-Sep-10
Sunol Sciences	Biconilog, 30-3000 MHz	JB3	1548	13-Jun-10
Rohde & Schwarz	EMI Test Receiver, 20 Hz-7 GHz	ESIB7	1630	26-Feb-10

Appendix B Test Data

T77502 9 Pages



EMC Test Data

Client:	Griffin Technology	Job Number:	J77421
Model:	iTrip AutoPilot 2009 (P2107)	Test-Log Number:	T77502
		Project Manager:	Sheareen
Contact:	Jeff Altheide		
Emissions Spec:	FCC 15.239	Class:	B
Immunity Spec:	-	Environment:	-

EMC Test Data

For The

Griffin Technology

Model

iTrip AutoPilot 2009 (P2107)

Date of Last Test: 11/21/2009

Client:	Griffin Technology	Job Number:	J77421
Model:	iTrip AutoPilot 2009 (P2107)	T-Log Number:	T77502
Contact:	Jeff Altheide	Account Manager:	Sheareen
Standard:	FCC 15.239	Class:	B

Run #1: Continued
EUT Upright

88.100	46.7	V	48.0	-1.3	AVG	80	1.4	Setting = 38
88.100	47.5	V	68.0	-20.5	PK	80	1.4	Setting = 38
88.100	44.9	H	48.0	-3.1	AVG	328	2.2	Setting = 38
88.100	45.6	H	68.0	-22.4	PK	328	2.2	Setting = 38
98.100	47.8	V	48.0	-0.2	AVG	86	1.4	Setting = 49
98.100	48.6	V	68.0	-19.4	PK	86	1.4	Setting = 49
98.100	47.9	H	48.0	-0.1	AVG	322	1.7	Setting = 46
98.100	48.6	H	68.0	-19.4	PK	322	1.7	Setting = 46
107.900	46.7	H	48.0	-1.3	AVG	338	3.0	Setting = 54
107.900	47.5	H	68.0	-20.5	PK	338	3.0	Setting = 54
107.900	40.8	V	48.0	-7.2	AVG	96	2.5	Setting = 54
107.900	41.7	V	68.0	-26.3	PK	96	2.5	Setting = 54

Fundamental Measurements - Summary of worse case

Frequency	Level	Pol	FCC 15.239		Detector	Azimuth	Height	Comments
MHz	dB μ V/m	v/h	Limit	Margin	Pk/QP/Avg	degrees	meters	

EUT Upright

88.100	46.7	V	48.0	-1.3	AVG	80	1.4	Setting = 38
88.100	47.5	V	68.0	-20.5	PK	80	1.4	Setting = 38
EUT Side								
98.100	47.5	H	48.0	-0.5	AVG	330	1.8	Setting = 42
98.100	48.2	H	68.0	-19.8	PK	330	1.8	Setting = 42

EUT Upright

107.900	46.7	H	48.0	-1.3	AVG	338	3.0	Setting = 54
107.900	47.5	H	68.0	-20.5	PK	338	3.0	Setting = 54

Client: Griffin Technology	Job Number: J77421
Model: iTrip AutoPilot 2009 (P2107)	T-Log Number: T77502
	Account Manager: Sheareen
Contact: Jeff Altheide	
Standard: FCC 15.239	Class: B

Run #2a: Radiated Emissions, 30 - 1000 MHz, EUT on Upright Orientation
Low Channel at 88.1 MHz

EUT and Test Configuration Details:

EUT configured to transmit a song and volume was set to maximum.

FCC Sample, Elliott tag 2009-2286

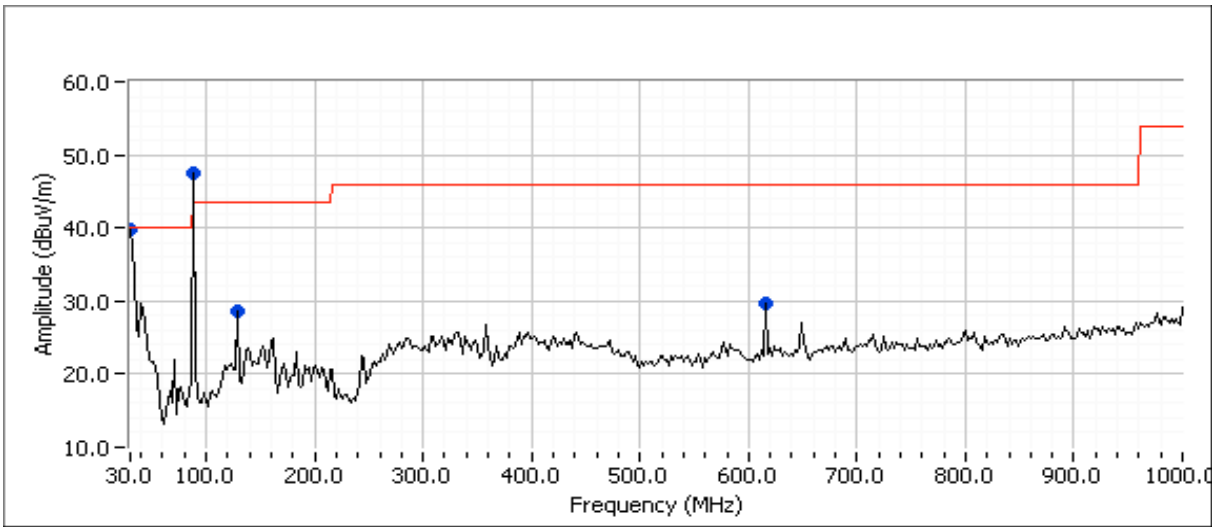

Frequency	Level	Pol	FCC Class B		Detector	Azimuth	Height	Comments
MHz	dBuV/m	v/h	Limit	Margin	Pk/QP/Avg	degrees	meters	
PK Readings								
31.291	39.9	V	40.0	-0.1	Peak	358	1.5	
88.084	47.6	V	-	-	Peak	74	1.5	Fundamental
129.620	28.7	V	43.5	-14.8	Peak	277	1.0	
613.850	29.7	H	46.0	-16.3	Peak	242	1.5	
QP Readings								
31.291	35.1	V	40.0	-4.9	QP	359	1.5	QP (1.00s)

Client: Griffin Technology	Job Number: J77421
Model: iTrip AutoPilot 2009 (P2107)	T-Log Number: T77502
	Account Manager: Sheareen
Contact: Jeff Altheide	
Standard: FCC 15.239	Class: B

**Run #2b: Radiated Emissions, 30 - 1000 MHz, EUT on Side Orientation
Middle Channel at 98.1 MHz**

EUT and Test Configuration Details:

EUT configured to transmit a song and volume was set to maximum.

FCC Sample, Elliott tag 2009-2286

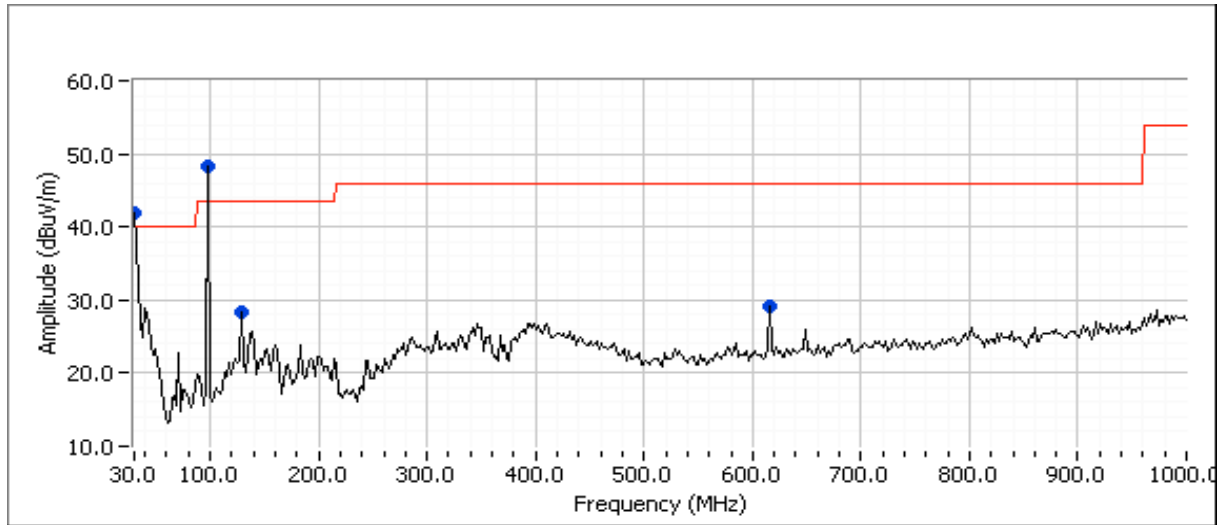

Frequency	Level	Pol	FCC Class B		Detector	Azimuth	Height	Comments
MHz	dB μ V/m	v/h	Limit	Margin	Pk/QP/Avg	degrees	meters	
PK Readings								
30.855	41.9	V	40.0	1.9	Peak	95	1.0	
98.114	48.2	H	-	-	Peak	332	3.0	Fundamental
613.850	29.1	H	46.0	-16.9	Peak	240	1.5	
129.620	28.4	V	43.5	-15.1	Peak	116	1.0	
QP Readings								
MHz	dB μ V/m	v/h	Limit	Margin	Pk/QP/Avg	degrees	meters	
30.855	39.4	V	40.0	-0.6	QP	97	1.0	QP (1.00s)

Client: Griffin Technology	Job Number: J77421
Model: iTrip AutoPilot 2009 (P2107)	T-Log Number: T77502
	Account Manager: Sheareen
Contact: Jeff Altheide	
Standard: FCC 15.239	Class: B

Run #2c: Radiated Emissions, 30 - 1000 MHz, EUT on Upright Orientation
High Channel at 107.9 MHz

EUT and Test Configuration Details:

EUT configured to transmit a song and volume was set to maximum.

FCC Sample, Elliott tag 2009-2286

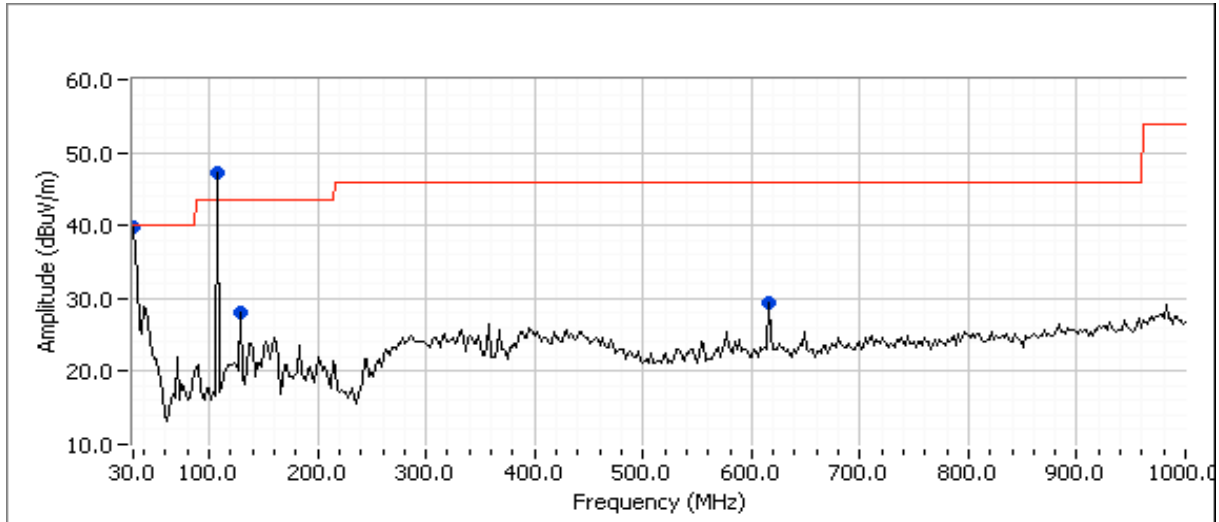

Frequency	Level	Pol	FCC Class B		Detector	Azimuth	Height	Comments
MHz	dBµV/m	v/h	Limit	Margin	Pk/QP/Avg	degrees	meters	
PK Readings								
31.306	39.8	V	40.0	-0.2	Peak	49	1.0	
107.896	47.2	H	-	-	Peak	333	3.0	Fundamental
129.620	28.1	V	43.5	-15.4	Peak	6	1.0	
613.850	29.4	H	46.0	-16.6	Peak	255	1.5	
QP Readings								
31.306	36.2	V	40.0	-3.8	QP	47	1.0	QP (1.00s)

Client: Griffin Technology	Job Number: J77421
Model: iTrip AutoPilot 2009 (P2107)	T-Log Number: T77502
Contact: Jeff Altheide	Account Manager: Sheareen
Standard: FCC 15.239	Class: B

Run #4: 20dB BW Measurements

EUT and Test Configuration Details:

EUT configured to transmit a song and volume was set to maximum.

FCC Sample, Elliott tag 2009-2286

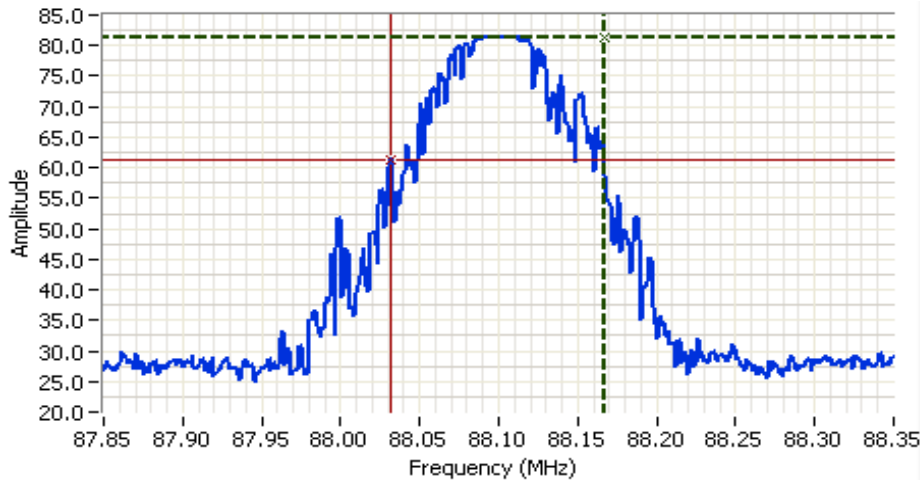

Analyzer Settings

Rohde&Schwarz,ESI
CF: 88.100 MHz
SPAN: 500 kHz
RB: 10.0 kHz
VB: 30.0 kHz
Detector: POS
Attn: 10 DB
RL Offset: 0.0 DB
Sweep Time: 15.0ms
Ref Lvl: 87.0 DBUV

Comments

20dB BW: 135 kHz
88.1 MHz

Cursor 1	88.1666	81.38		Delta Freq.	135 kHz
Cursor 2	88.0314	61.38		Delta Amplitude	20.00

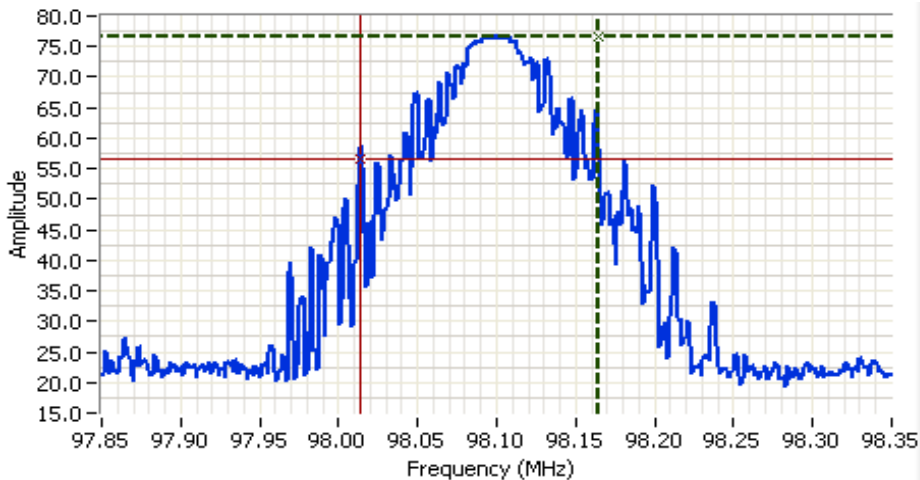

Analyzer Settings

Rohde&Schwarz,ESI
CF: 98.100 MHz
SPAN: 500 kHz
RB: 10.0 kHz
VB: 30.0 kHz
Detector: POS
Attn: 10 DB
RL Offset: 0.0 DB
Sweep Time: 15.0ms
Ref Lvl: 87.0 DBUV

Comments

20dB BW: 151 kHz
98.1 MHz

Cursor 1	98.1646	76.50		Delta Freq.	151 kHz
Cursor 2	98.0133	56.50		Delta Amplitude	20.00



Client: Griffin Technology	Job Number: J77421
Model: iTrip AutoPilot 2009 (P2107)	T-Log Number: T77502
Contact: Jeff Altheide	Account Manager: Sheareen
Standard: FCC 15.239	Class: B

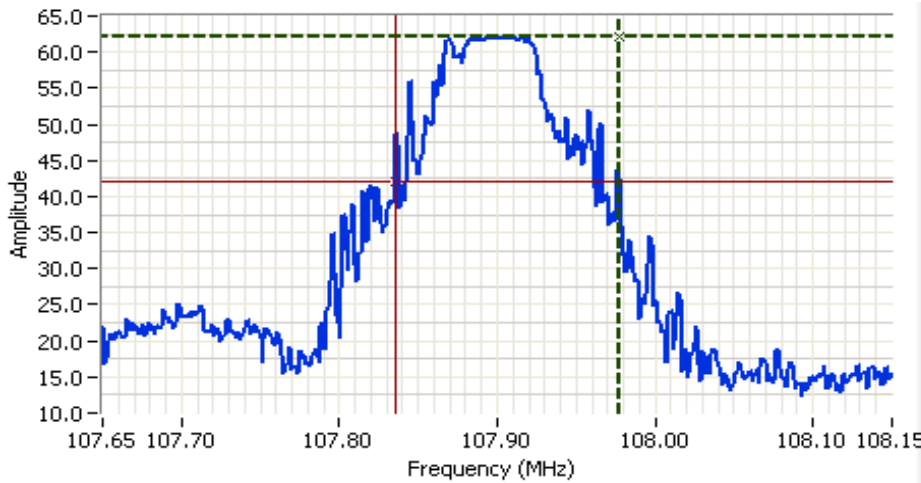

Analyzer Settings
 Rohde&Schwarz, ESI
 CF: 107.900 MHz
 SPAN: 500 kHz
 RB: 10.0 kHz
 VB: 30.0 kHz
 Detector: POS
 Attn: 10 DB
 RL Offset: 0.0 DB
 Sweep Time: 15.0ms
 Ref Lvl: 87.0 DBUV

Comments
 20dB BW: 142 kHz
 107.9 MHz

Cursor 1	107.9777	62.01	
Cursor 2	107.8354	42.01	

Delta Freq. 142 kHz
 Delta Amplitude 20.00



99% BW for Canada

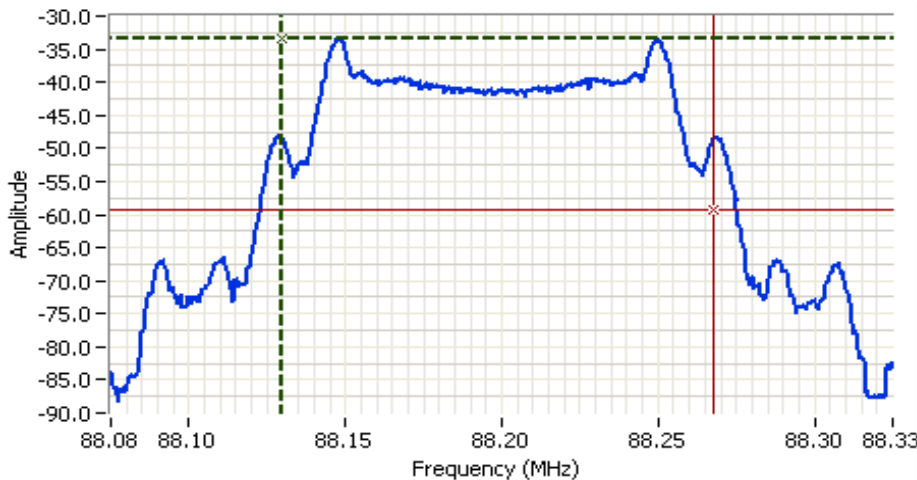

Analyzer Settings
 Agilent Technologies, E4446A
 CF: 88.200 MHz
 SPAN: 250 kHz
 RB: 3.00 kHz
 VB: 10.0 kHz
 Detector: POS
 Attn: 10 DB
 RL Offset: 0.0 DB
 Sweep Time: 26.0ms
 Ref Lvl: -15.0 DBM

Comments
 99% BW: 138 kHz
 20°C 15.6Vdc

Cursor 1	88.1299	-33.35	
Cursor 2	88.2676	-59.35	

Delta Freq. 138 kHz
 Delta Amplitude 26.00

