

TEST REPORT

Applicant: CC&C Technologies, Inc.
Address: 8F, No.150, Jian Yi Rd, Zhonghe District, New Taipei City,235, Taiwan
Equipment Type: ac2x2+BT5.0 USB2.0
Model Name: CM-8822CU-V2
Brand Name: CC&C
FCC ID: PANCM8822CUV2
Test Standard: 47 CFR Part 15 Subpart C (refer section 3.1)
Sample Arrival Date: Nov. 28, 2022
Test Date: Dec. 02, 2022 - Dec. 13, 2022
Date of Issue: Feb. 13, 2023

ISSUED BY:

Shenzhen BALUN Technology Co., Ltd.

Tested by: Julie Zhu

Checked by: Ye Hongji

Approved by: Liao Jianming
(Technical Director)

Julie . zhu

Ye Hongji

Liao Jianming

Revision History		
Version	Issue Date	Revisions
Rev. 01	Jan. 05, 2023	Initial Issue
Rev. 02	Feb. 13, 2023	Updated antenna gain

TABLE OF CONTENTS

1	GENERAL INFORMATION.....	4
1.1	Test Laboratory	4
1.2	Test Location	4
2	PRODUCT INFORMATION	5
2.1	Applicant Information	5
2.2	Manufacturer Information.....	5
2.3	Factory Information.....	5
2.4	General Description for Equipment under Test (EUT).....	5
2.5	Technical Information	6
3	SUMMARY OF TEST RESULTS	8
3.1	Test Standards	8
3.2	Test Verdict	8
4	GENERAL TEST CONFIGURATIONS	9
4.1	Test Environments.....	9
4.2	Test Equipment List.....	9
4.3	Measurement Uncertainty.....	10
4.4	Description of Test Setup	10
4.5	Measurement Results Explanation Example.....	13
5	TEST ITEMS	14
5.1	Antenna Requirements	14
5.2	Output Power	15
5.3	Occupied Bandwidth.....	17
5.4	Conducted Spurious Emission.....	18
5.5	Band Edge (Authorized-band band-edge).....	20

5.6	Conducted Emission.....	22
5.7	Radiated Spurious Emission.....	23
5.8	Band Edge (Restricted-band band-edge).....	28
5.9	Power Spectral density (PSD)	29
ANNEX A	TEST RESULT	30
A.1	Output Power	30
A.2	Occupied Bandwidth.....	37
A.3	Conducted Spurious Emissions	37
A.4	Band Edge (Authorized-band band-edge).....	37
A.5	Conducted Emissions	38
A.6	Radiated Emission.....	40
A.7	Band Edge (Restricted-band band-edge).....	72
A.8	Power Spectral Density (PSD).....	92
ANNEX B	TEST SETUP PHOTOS	93
ANNEX C	EUT EXTERNAL PHOTOS.....	93
ANNEX D	EUT INTERNAL PHOTOS.....	93

1 GENERAL INFORMATION

1.1 Test Laboratory

Name	Shenzhen BALUN Technology Co., Ltd.
Address	Block B, 1/F, Baisha Science and Technology Park, Shahe Xi Road, Nanshan District, Shenzhen, Guangdong Province, P. R. China
Phone Number	+86 755 6685 0100

1.2 Test Location

Name	Shenzhen BALUN Technology Co., Ltd.
Location	<input checked="" type="checkbox"/> Block B, 1/F, Baisha Science and Technology Park, Shahe Xi Road, Nanshan District, Shenzhen, Guangdong Province, P. R. China
	<input type="checkbox"/> 1/F, Building B, Ganghongji High-tech Intelligent Industrial Park, No. 1008, Songbai Road, Yangguang Community, Xili Sub-district, Nanshan District, Shenzhen, Guangdong Province, P. R. China
Accreditation Certificate	The laboratory is a testing organization accredited by FCC as a accredited testing laboratory. The designation number is CN1196.

2 PRODUCT INFORMATION

2.1 Applicant Information

Applicant	CC&C Technologies, Inc.
Address	8F, No.150, Jian Yi Rd, Zhonghe District, New Taipei City,235, Taiwan

2.2 Manufacturer Information

Manufacturer	CC&C Technologies, Inc.
Address	8F, No.150, Jian Yi Rd, Zhonghe District, New Taipei City,235, Taiwan

2.3 Factory Information

Factory	Kunshan CC&C Technologies, Co., Ltd
Address	No.9 building, 3rd Main Street, Kunshan Free Trade Zone, Jiangsu Province, P. R. China

2.4 General Description for Equipment under Test (EUT)

EUT Name	ac2x2+BT5.0 USB2.0
Model Name Under Test	CM-8822CU-V2
Series Model Name	N/A
Description of Model name differentiation	N/A
Hardware Version	V. A
Software Version	V15(WIFI+BT)
Dimensions (Approx.)	N/A
Weight (Approx.)	N/A

2.5 Technical Information

Network and Wireless connectivity	Bluetooth (BR+EDR+BLE) 2.4G WIFI 802.11b, 802.11g, 802.11n(HT20/40) 5G WIFI 802.11a, 802.11n(HT20/40), 802.11ac(VHT20/40/80) U-NII-1/3
-----------------------------------	---

The requirement for the following technical information of the EUT was tested in this report:

Frequency Range	802.11b/g/n(20 MHz): 2.412 GHz - 2.462 GHz $f_c = 2412 \text{ MHz} + (N-1)*5 \text{ MHz}$, where - f_c = "Operating Frequency" in MHz, - N = "Channel Number" with the range from 1 to 11. 802.11n(40 MHz): 2.422 GHz - 2.452 GHz $f_c = 2412 \text{ MHz} + (N-1)*5 \text{ MHz}$, where - f_c = "Operating Frequency" in MHz, - N = "Channel Number" with the range from 3 to 9.	
Modulation Type	DSSS, OFDM	
Product Type	<input checked="" type="checkbox"/> Mobile <input type="checkbox"/> Portable <input type="checkbox"/> Fix Location	
Antenna System (eg., MIMO, Smart Antenna)	Cyclic Delay Diversity (CDD) for 802.11b/g Multi Input Multi Output (MIMO) for 802.11n	
Categorization as Correlated or Completely Uncorrelated	Categorization as Correlated for 802.11b/g Categorization as Uncorrelated for 802.11n/	
Antenna Type	Main Antenna	External Antenna
	Aux Antenna	
Antenna Gain	Main Antenna	2.2 dBi
	Aux. Antenna	2.2 dBi
Total directional gain	For power spectral density(PSD) measurements	Correlated: 5.2 dBi Formulas: Directional gain = $G_{ANT} + 10 \log(N_{ANT})$ dBi
		Uncorrelated: 2.2 dBi Formulas: Directional gain = G_{ANT}
About the Product	Only the WIFI 802.11b, 802.11g and 802.11n (HT20/40) was tested in this report.	

Mode	Antenna		
	Main Antenna	Aux. Antenna	MIMO
802.11b	√	√	--
802.11g	√	√	--
802.11n20	√	√	√
802.11n40	√	√	√

Note: All the configurations were tested, but only the worst data was shown in this report.

Modulation technology	Modulation Type	Transfer Rate (Mbps)(Single RF path)
DSSS (802.11b)	DBPSK	1
	DQPSK	2
	CCK	5.5/11
OFDM (802.11g)	BPSK	6/9
	QPSK	12/18
	16QAM	24/36
	64QAM	48/54
OFDM (802.11n-20 MHz)	BPSK	6.5/7.2
	QPSK	13/19.5/14.4/21.7
	16QAM	26/39/28.9/43.3
	64QAM	52/58.5/65/57.8/65/72.2
OFDM (802.11n-40 MHz)	BPSK	13.5/15
	QPSK	27/40.5/30/45
	16QAM	54/81/60/90
	64QAM	108/121.5/135/120/150

Note: Preliminary tests were performed in different data rate in above table to find the worst radiated emission. The data rate shown in the table below is the worst-case rate with respect to the specific test item. Investigation has been done on all the possible configurations for searching the worst cases. The following table is a list of the test modes shown in this test report.

Test Items	Mode	Data Rate	Channel	
Output Power	11b/11g/11n20/11n40	1/6/6.5/13.5 Mbps	1/6/11	3/6/9
Occupied Bandwidth	11b/11g/11n20/11n40	1/6/6.5/13.5 Mbps	1/6/11	3/6/9
Conducted Spurious Emission	11b/11g/11n20/11n40	1/6/6.5/13.5 Mbps	1/6/11	3/6/9
Conducted Emission	11b/11g/11n20/11n40	1/6/6.5/13.5 Mbps	1/6/11	3/6/9
Radiated Spurious Emission	11b/11g/11n20/11n40	1/6/6.5/13.5 Mbps	1/6/11	3/6/9
Band Edge	11b/11g/11n20/11n40	1/6/6.5/13.5 Mbps	1/6/11	3/6/9
Power spectral density (PSD)	11b/11g/11n20/11n40	1/6/6.5/13.5 Mbps	1/6/11	3/6/9

Note: The above EUT information in section 2.4 and 2.6 was declared by manufacturer and for more detailed features description, please refer to the manufacturer's specifications or user's manual.

3 SUMMARY OF TEST RESULTS

3.1 Test Standards

No.	Identity	Document Title
1	47 CFR Part 15, Subpart C	Intentional radiators of radio frequency equipment
2	KDB Publication 662911 D01v02r01	Emissions Testing of Transmitters with Multiple Outputs in the Same Band (e.g., MIMO, Smart Antenna, etc)
3	ANSI C63.10-2013	American National Standard of Procedures for Compliance Testing of Unlicensed Wireless Devices
4	KDB Publication 558074 D01v05r02	GUIDANCE FOR COMPLIANCE MEASUREMENTS ON DIGITAL TRANSMISSION SYSTEM, FREQUENCY HOPPING SPREAD SPECTRUM SYSTEM, AND HYBRID SYSTEM DEVICES OPERATING UNDER SECTION 15.247 OF THE FCC RULES

3.2 Test Verdict

No.	Description	FCC PART No.	Test Result	Verdict	Remark
1	Antenna Requirement	15.203	N/A	Pass	Note ¹
2	Output Power	15.247 (b)	ANNEX A.1	Pass	--
3	Occupied Bandwidth	15.247 (a)	ANNEX A.2	Pass	Note ³
4	Conducted Spurious Emission	15.247 (d)	ANNEX A.3	Pass	Note ³
5	Band Edge(Authorized-band band-edge)	15.247 (d)	ANNEX A.4	Pass	Note ³
6	Conducted Emission	15.207	ANNEX A.5	Pass	--
7	Radiated Spurious Emission	15.209; 15.247 (d)	ANNEX A.6	Pass	--
8	Band Edge(Restricted-band band-edge)	15.209; 15.247 (d)	ANNEX A.7	Pass	--
9	Power spectral density (PSD)	15.247 (e)	ANNEX A.8	Pass	Note ³
10	Receiver Spurious Emissions	N/A	N/A	N/A	Note ²

Note ¹: Please refer to section 5.1.

Note ²: Only radio communication receivers operating in stand-alone mode within the band 30-960 MHz, as well as scanner receivers, are subject to Industry Canada requirements, so this test is not applicable.

Note ³: Compared with the EUT in the test report BL-EC19A0003-603, the EUT in this report has replaced the radiation antenna, Other hardware circuits and software are the same as those mentioned in the test report BL-EC19A0003-603.

Therefore, so just radiation test of Output Power, Conducted Emissions, Radiated Spurious Emissions and Band Edge (Restricted-band band-edge) were retested in this report. Other test items please refer to the report BL-EC19A0003-603 issued by Shenzhen BALUN Technology Co., Ltd. on December 12, 2019 for all test data.

4 GENERAL TEST CONFIGURATIONS

4.1 Test Environments

During the measurement, the normal environmental conditions were within the listed ranges:

Relative Humidity	45% to 55%	
Atmospheric Pressure	100 kPa to 102 kPa	
Temperature	NT (Normal Temperature)	+20.7°C to +25°C
Working Voltage of the EUT	NV (Normal Voltage)	DC 3.3V

4.2 Test Equipment List

Description	Manufacturer	Model	Serial No.	Cal. Date	Cal. Due
Spectrum Analyzer	ROHDE&SCHWARZ	FSV-40	101544	2022.01.04	2023.01.03
Spectrum Analyzer	KEYSIGHT	N9020A	MY52510065	2022.09.06	2023.09.05
Signaling Unit	ROHDE&SCHWARZ	CMW500	171150	2022.06.29	2023.06.28
Test Antenna-Horn(1-18 GHz)	SCHWARZBECK	BBHA 9120D	01631	2022.02.03	2025.02.02
Test Antenna-Horn (18-40 GHz)	A-INFO	LB- 180400KF	J211060273	2021.07.02	2024.07.01
Anechoic Chamber	RAINFORD	9m*6m*6m	N/A	2021.09.04	2024.09.03
EMI Receiver	ROHDE&SCHWARZ	ESRP	101036	2022.09.09	2023.09.08
Test Antenna-Bi-Log(30 MHz-1 GHz)	SCHWARZBECK	VULB 9168	00883	2022.04.01	2025.03.31
Test Antenna-Loop(9 kHz-30 MHz)	SCHWARZBECK	FMZB 1519	1519-037	2021.04.16	2024.04.15
Anechoic Chamber	EMC Electronic Co., Ltd	20.10*11.60 *7.35m	N/A	2021.08.15	2024.08.14
EMI Receiver	KEYSIGHT	N9010B	MY57110309	2022.09.09	2023.09.08
LISN	SCHWARZBECK	NSLK 8127	8127-687	2022.06.01	2023.05.31
Shielded Enclosure	YiHeng Electronic Co., Ltd	3.5m*3.1m* 2.8m	N/A	2022.02.19	2025.02.18
Amplifier (1-12GHz)	COM-MV	LSCX_LNA 1-12G-01	180602	2020.09.08	2023.09.07
Amplifier (7-18GHz)	COM-MV	XKu_LNA7- 18G-01	180601	2020.09.08	2023.09.07
Amplifier (18-40GHz)	COM-MV	KA_LNA18- 40G-01	18050001	2020.09.08	2023.09.07
Power Sensor	ROHDE&SCHWARZ	NRP18S	102521	2022.03.09	2023.03.08

4.3 Measurement Uncertainty

The following measurement uncertainty levels have been estimated for tests performed on the EUT as specified in CISPR 16-4-2.

This uncertainty represents an expanded uncertainty expressed at approximately the 95% confidence level using a coverage factor of k=2.

Parameters	Uncertainty
Occupied Channel Bandwidth	2.8%
RF output power, conducted	1.28 dB
Power Spectral Density, conducted	1.30 dB
Unwanted Emissions, conducted	1.84 dB
All emissions, radiated	5.36 dB
Temperature	0.82°C
Humidity	4.1%

4.4 Description of Test Setup

4.4.1 For Antenna Port Test

$$\text{Conducted value (dBm)} = \text{Measurement value (dBm)} + \text{cable loss (dB)}$$

For example: the measurement value is 10 dBm and the cable 0.5dBm used, then the final result of EUT:

$$\text{Conducted value (dBm)} = 10 \text{ dBm} + 0.5 \text{ dB} = 10.5 \text{ dBm}$$

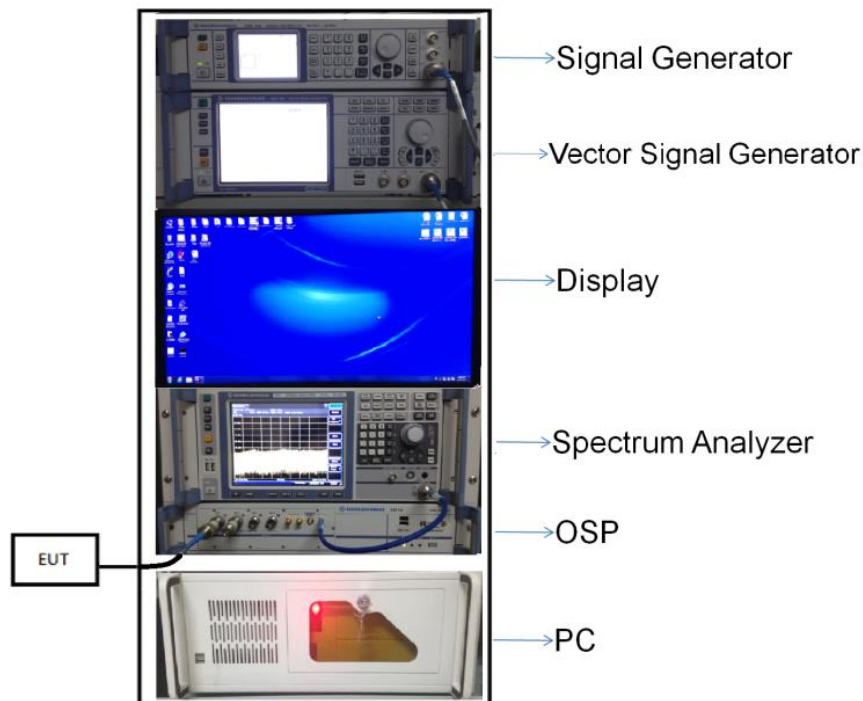

(Diagram 1)

4.4.2 For AC Power Supply Port Test

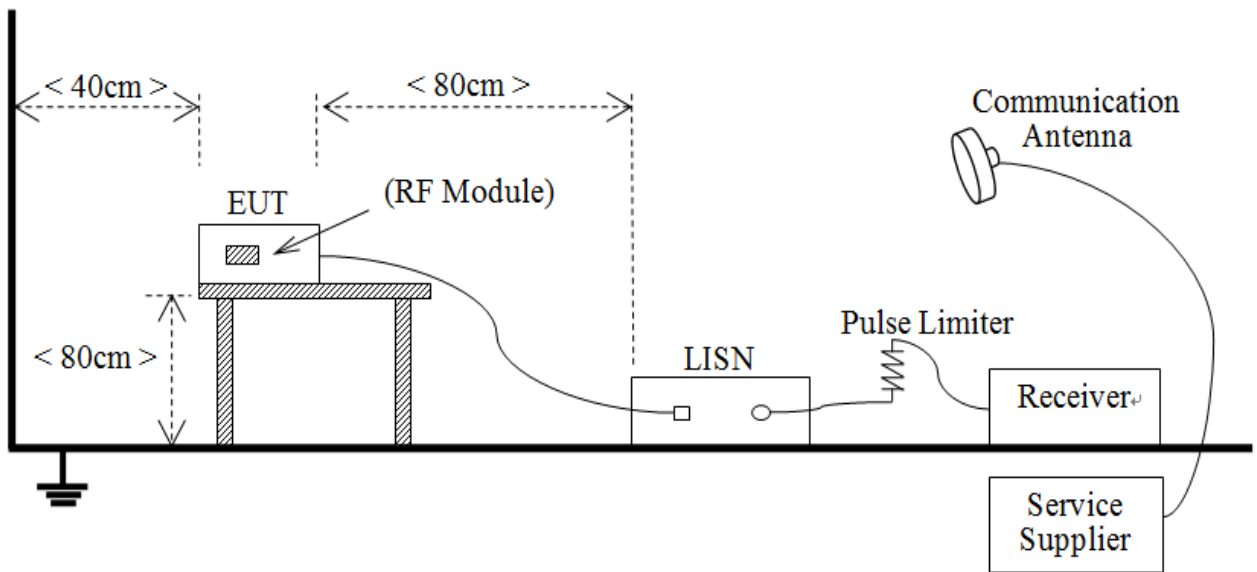

(Diagram 2)

4.4.3 For Radiated Test (Below 30 MHz)

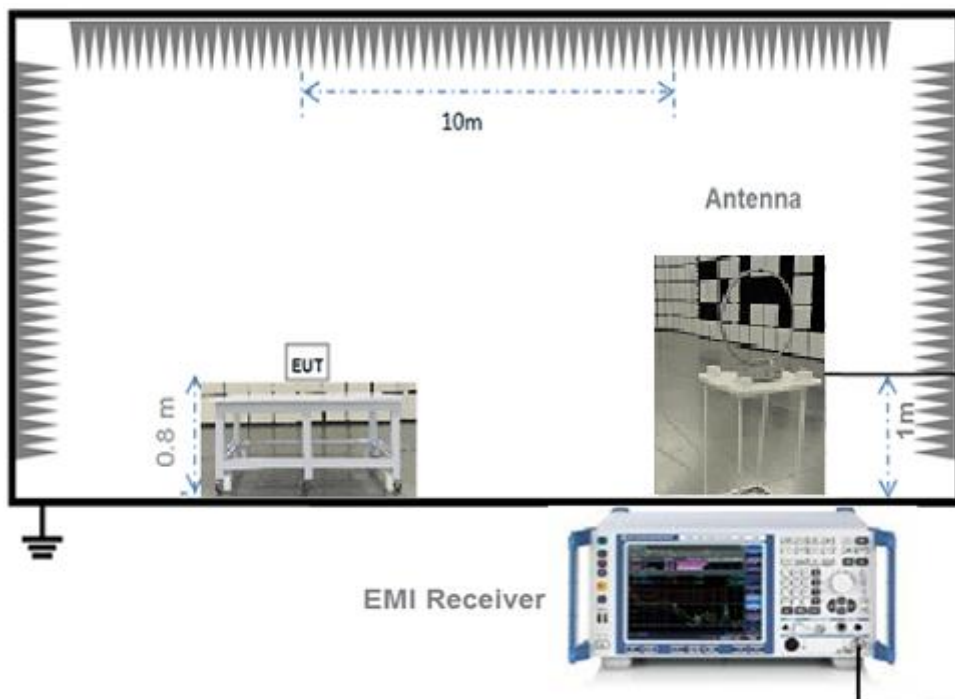

(Diagram 3)

4.4.4 For Radiated Test (30 MHz-1 GHz)

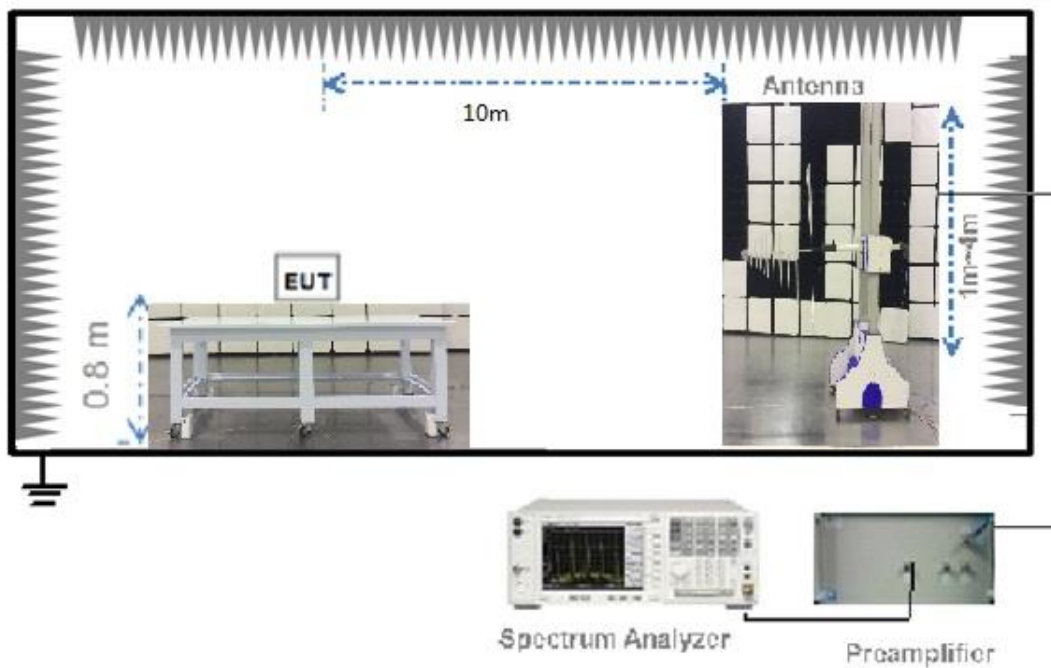

(Diagram 4)

4.4.5 For Radiated Test (Above 1 GHz)

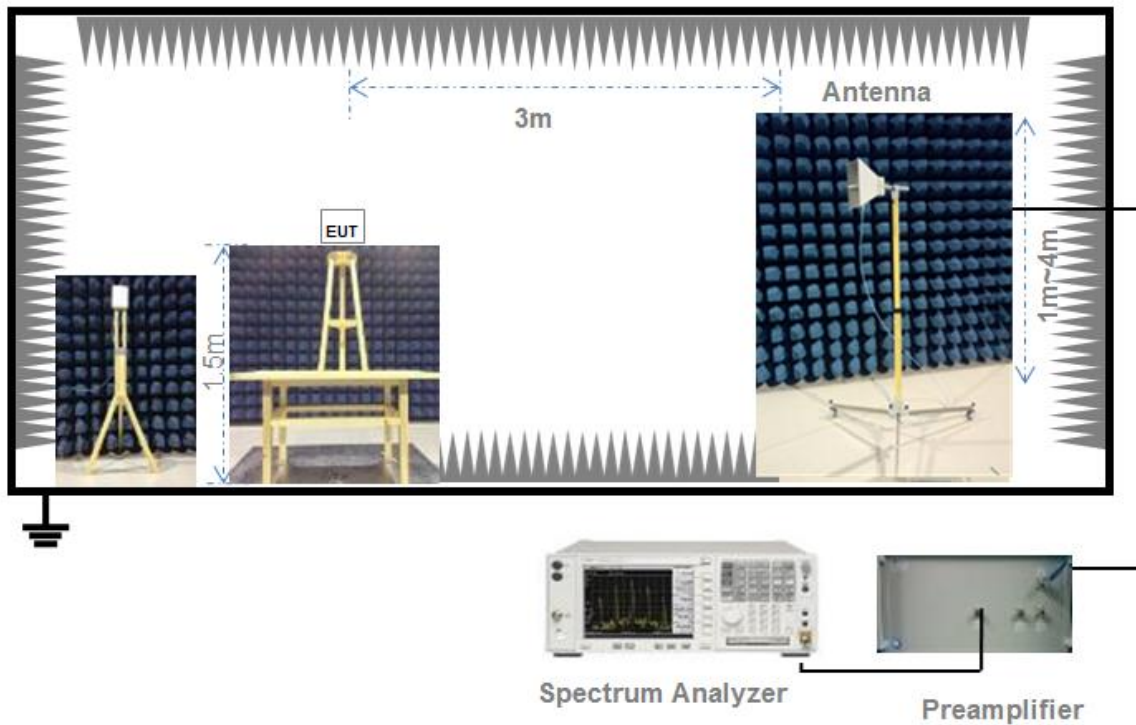

(Diagram 5)

4.5 Measurement Results Explanation Example

4.5.1 For conducted test items:

The offset level is set in the spectrum analyzer to compensate the RF cable loss and attenuator between EUT conducted output port and spectrum analyzer. With the offset compensation, the spectrum analyzer reading level is exactly the EUT RF output level.

The spectrum analyzer offset is derived from RF cable loss and attenuator factor.

Offset = RF cable loss + attenuator factor.

4.5.2 For radiated band edges and spurious emission test:

$$E = \text{EIRP} - 20 \log D + 104.8$$

where:

E = electric field strength in dB μ V/m,

EIRP = equivalent isotropic radiated power in dBm

D = specified measurement distance in meters.

EIRP = Measure Conducted output power Value (dBm) + Maximum transmit antenna gain (dBi) + the appropriate maximum ground reflection factor (dB)

5 TEST ITEMS

5.1 Antenna Requirements

5.1.1 Relevant Standards

FCC §15.203

An intentional radiator shall be designed to ensure that no antenna other than that furnished by the responsible party shall be used with the device. The use of a permanently attached antenna or of an antenna that uses a unique coupling to the intentional radiator shall be considered sufficient to comply with the provisions of this section. The manufacturer may design the unit so that a broken antenna can be replaced by the user, but the use of a standard antenna jack or electrical connector is prohibited. This requirement does not apply to carrier current devices or to devices operated under the provisions of § 15.211, § 15.213, § 15.217, § 15.219, or § 15.221. Further, this requirement does not apply to intentional radiators that must be professionally installed, such as perimeter protection systems and some field disturbance sensors, or to other intentional radiators which, in accordance with § 15.31(d), must be measured at the installation site. However, the installer shall be responsible for ensuring that the proper antenna is employed so that the limits in this part are not exceeded.

If directional gain of transmitting antennas is greater than 6 dBi, the power shall be reduced by the same level in dB comparing to gain minus 6 dBi. For the fixed point-to-point operation, the power shall be reduced by one dB for every 3 dB that the directional gain of the antenna exceeds 6 dBi. The use of a permanently attached antenna or of an antenna that uses a unique coupling to the intentional radiator shall be considered sufficient to comply with the FCC rule.

5.1.2 Antenna Anti-Replacement Construction

The Antenna Anti-Replacement as following method:

Protected Method	Description
Compliance with 15.203, use of a standard antenna jack or electrical connector is prohibited.	The antenna is the unique connector with a wire antenna.

Reference Documents	Item
Photo	Please refer to the EUT Photo documents.

5.1.3 Antenna Gain

The antenna peak gain of EUT is less than 6 dBi. Therefore, it is not necessary to reduce maximum peak output power limit.

5.2 Output Power

5.2.1 Test Limit

FCC § 15.247(b)

For systems using digital modulation in the 902-928 MHz, 2400-2483.5 MHz, and 5725-5850 MHz bands: 1 Watt. As an alternative to a peak power measurement, compliance with the one Watt limit can be based on a measurement of the maximum conducted output power. Maximum Conducted Output Power is defined as the total transmit power delivered to all antennas and antenna elements averaged across all symbols in the signaling alphabet when the transmitter is operating at its maximum power control level. Power must be summed across all antennas and antenna elements.

5.2.2 Test Setup

See section 4.5.1 for test setup description for the antenna port. The photo of test setup please refer to ANNEX B.

5.2.3 Test Procedure

Maximum peak conducted output power

The maximum peak conducted output power may be measured using a broadband peak RF power meter. The power meter shall have a video bandwidth that is greater than or equal to the DTS bandwidth and shall utilize a fast-responding diode detector.

Maximum conducted (average) output power (Reporting Only)

a) As an alternative to spectrum analyzer or EMI receiver measurements, measurements may be performed

using a wideband RF power meter with a thermocouple detector or equivalent if all of the conditions listed below are satisfied.

- 1) The EUT is configured to transmit continuously, or to transmit with a constant duty factor.
- 2) At all times when the EUT is transmitting, it shall be transmitting at its maximum power control level.
- 3) The integration period of the power meter exceeds the repetition period of the transmitted signal by at least a factor of five.

b) If the transmitter does not transmit continuously, measure the duty cycle (x) of the transmitter output signal as

described in Section 6.0.

c) Measure the average power of the transmitter. This measurement is an average over both the on and off periods of the transmitter.

d) Adjust the measurement in dBm by adding $10\log(1/x)$, where x is the duty cycle to the measurement result.

Measurements of duty cycle

The zero-span mode on a spectrum analyzer or EMI receiver is used if the response time and spacing between bins on the sweep are sufficient to permit accurate measurements of the on and off times of the transmitted signal.

Set the center frequency of the instrument to the center frequency of the transmission.

Set $RBW \geq OBW$ if possible; otherwise, set RBW to the largest available value.

Set $VBW \geq RBW$. Set detector = peak or average.

The zero-span measurement method shall not be used unless both RBW and VBW are $> 50/T$ and the number of sweep points across duration T exceeds 100. (For example, if VBW and/or RBW are limited to 3 MHz, then the zero-span method of measuring duty cycle shall not be used if $T \leq 16.7$ microseconds.)

5.2.4 Test Result

Please refer to ANNEX A.1.

5.3 Occupied Bandwidth

5.3.1 Limit

FCC §15.247(a)

Make the measurement with the spectrum analyzer's resolution bandwidth (RBW) = 100 kHz. In order to make an accurate measurement, set the span greater than RBW. The 6 dB bandwidth must be greater than 500 kHz.

5.3.2 Test Setup

See section 4.5.1 for test setup description for the antenna port. The photo of test setup please refer to ANNEX B.

5.3.3 Test Procedure

Use the following spectrum analyzer settings:

Set RBW = 100 kHz.

Set the video bandwidth (VBW) \geq 3 RBW.

Detector = Peak.

Trace mode = max hold.

Sweep = auto couple.

Allow the trace to stabilize.

Measure the maximum width of the emission that is constrained by the frequencies associated with the two outermost amplitude points (upper and lower frequencies) that are attenuated by 6 dB relative to the maximum level measured in the fundamental emission.

5.3.4 Test Result

Please refer to ANNEX A.2.

5.4 Conducted Spurious Emission

5.4.1 Limit

FCC §15.247(d)

In any 100 kHz bandwidth outside the frequency band in which the spread spectrum or digitally modulated intentional radiator is operating, the radio frequency power that is produced by the intentional radiator shall be at least 20 dB below that in the 100 kHz bandwidth within the band that contains the highest level of the desired power, based on either an RF conducted or a radiated measurement.

5.4.2 Test Setup

See section 4.5.1 for test setup description for the antenna port. The photo of test setup please refer to ANNEX B.

5.4.3 Test Procedure

The DTS rules specify that in any 100 kHz bandwidth outside of the authorized frequency band, the power shall be attenuated according to the following conditions:

- a) If the maximum peak conducted output power procedure was used to demonstrate compliance as described in 9.1, then the peak output power measured in any 100 kHz bandwidth outside of the authorized frequency band shall be attenuated by at least 20 dB relative to the maximum in-band peak PSD level in 100 kHz (i.e., 20 dBc).
- b) If maximum conducted (average) output power was used to demonstrate compliance as described in 9.2, then the peak power in any 100 kHz bandwidth outside of the authorized frequency band shall be attenuated by at least 30 dB relative to the maximum in-band peak PSD level in 100 kHz (i.e., 30 dBc).
- c) In either case, attenuation to levels below the 15.209 general radiated emissions limits is not required.

The following procedures shall be used to demonstrate compliance to these limits. Note that these procedures can be used in either an antenna-port conducted or radiated test set-up. Radiated tests must conform to the test site requirements and utilize maximization procedures defined herein.

Reference level measurement

Establish a reference level by using the following procedure:

Set instrument center frequency to DTS channel center frequency.

Set the span to ≥ 1.5 times the DTS bandwidth.

Set the RBW = 100 kHz.

Set the VBW $\geq 3 \times$ RBW.

Detector = peak.

Sweep time = auto couple.

Trace mode = max hold.

Allow trace to fully stabilize.

Use the peak marker function to determine the maximum PSD level.

Emission level measurement

Use the following spectrum analyzer settings:

Span = wide enough to capture the peak level of the in-band emission and all spurious emissions (e.g., harmonics) from the lowest frequency generated in the EUT up through the 10th harmonic. Typically, several plots are required to cover this entire span.

Set the RBW = 100 kHz.

Set the VBW $\geq 3 \times$ RBW.

Detector = peak.

Sweep time = auto couple.

Trace mode = max hold.

Allow trace to fully stabilize.

Use the peak marker function to determine the maximum amplitude level.

Ensure that the amplitude of all unwanted emissions outside of the authorized frequency band (excluding restricted frequency bands) are attenuated by at least the minimum requirements specified in 11.1 a) or 11.1 b). Report the three highest emissions relative to the limit.

5.4.4 Test Result

Please refer to ANNEX A.3.

5.5 Band Edge (Authorized-band band-edge)

5.5.1 Limit

FCC §15.247(d)

In any 100 kHz bandwidth outside the frequency band in which the spread spectrum or digitally modulated intentional radiator is operating, the radio frequency power that is produced by the intentional radiator shall be at least 20 dB below that in the 100 kHz bandwidth within the band that contains the highest level of the desired power, based on either an RF conducted or a radiated measurement.

5.5.2 Test Setup

See section 4.5.1 for test setup description for the antenna port. The photo of test setup please refer to ANNEX B.

5.5.3 Test Procedure

The following procedures may be used to determine the peak or average field strength or power of an unwanted emission that is within 2 MHz of the authorized band edge. If a peak detector is utilized, use the procedure described in 13.2.1. Use the procedure described in 13.2.2 when using an average detector and the EUT can be configured to transmit continuously (i.e., duty cycle $\geq 98\%$). Use the procedure described in 13.2.3 when using an average detector and the EUT cannot be configured to transmit continuously but the duty cycle is constant (i.e., duty cycle variations are less than ± 2 percent). Use the procedure described in 13.2.4 when using an average detector for those cases where the EUT cannot be configured to transmit continuously and the duty cycle is not constant (duty cycle variations equal or exceed 2 percent).

When using a peak detector to measure unwanted emissions at or near the band edge (within 2 MHz of the authorized band), the following integration procedure can be used.

Set instrument center frequency to the frequency of the emission to be measured (must be within 2 MHz of the authorized band edge).

Set span to 2 MHz

RBW = 100 kHz.

VBW $\geq 3 \times$ RBW.

Detector = peak.

Sweep time = auto.

Trace mode = max hold.

Allow sweep to continue until the trace stabilizes (required measurement time may increase for low duty cycle applications)

Compute the power by integrating the spectrum over 1 MHz using the analyzer's band power measurement function with band limits set equal to the emission frequency (femission) ± 0.5 MHz. If the instrument does not have a band power function, then sum the amplitude levels (in power units) at 100 kHz intervals extending across the 1 MHz spectrum defined by femission ± 0.5 MHz.

Standard method(The 99% OBW of the fundamental emission is without 2 MHz of the authorized band):

Span: Wide enough to capture the peak level of the emission operating on the channel closest to the band edge, as well as any modulation products that fall outside of the authorized band of operation.

Reference level: As required to keep the signal from exceeding the maximum instrument input mixer level for linear operation. In general, the peak of the spectral envelope shall be more than $[10 \log(\text{OBW}/\text{RBW})]$ below the reference level. Specific guidance is given in 4.1.5.2.

Attenuation: Auto (at least 10 dB preferred).

Sweep time: Coupled.

Resolution bandwidth: 100 kHz.

Video bandwidth: 300 kHz.

Detector: Peak.

Trace: Max hold.

5.5.4 Test Result

Please refer to ANNEX A.4.

5.6 Conducted Emission

5.6.1 Limit

FCC §15.207

For an intentional radiator that is designed to be connected to the public utility (AC) power line, the radio frequency voltage that is conducted back onto the AC power line on any frequency within the band 150 kHz to 30 MHz shall not exceed the limits in the following table, as measured using a 50 μ H/50 Ω line impedance stabilization network (LISN).

Frequency range (MHz)	Conducted Limit (dB μ V)	
	Quai-peak	Average
0.15 - 0.50	66 to 56	56 to 46
0.50 - 5	56	46
0.50 - 30	60	50

5.6.2 Test Setup

See section 4.5.2 for test setup description for the AC power supply port. The photo of test setup please refer to ANNEX B.

5.6.3 Test Procedure

The maximum conducted interference is searched using Peak (PK), if the emission levels more than the AV and QP limits, and that have narrow margins from the AV and QP limits will be re-measured with AV and QP detectors. Tests for both L phase and N phase lines of the power mains connected to the EUT are performed. Refer to recorded points and plots below.

Devices subject to Part 15 must be tested for all available U.S. voltages and frequencies (such as a nominal 120 VAC, 50/60 Hz and 240 VAC, 50/60 Hz) for which the device is capable of operation. A device rated for 50/60 Hz operation need not be tested at both frequencies provided the radiated and line conducted emissions are the same at both frequencies.

5.6.4 Test Result

Please refer to ANNEX A.5.

5.7 Radiated Spurious Emission

5.7.1 Limit

FCC §15.209&15.247(d)

Radiated emission outside the frequency band attenuation below the general limits specified in FCC section 15.209(a) is not required. In addition, radiated emissions which fall in the restricted bands, as defined in FCC section 15.205(a), must also comply with the radiated emission limits specified in FCC section 15.209(a).

According to FCC section 15.209 (a), except as provided elsewhere in this subpart, the emissions from an intentional radiator shall not exceed the field strength levels specified in the following table:

Frequency (MHz)	Field Strength ($\mu\text{V}/\text{m}$)	Measurement Distance (m)
0.009 - 0.490	2400/F(kHz)	300
0.490 - 1.705	24000/F(kHz)	30
1.705 - 30.0	30	30
30 - 88	100	3
88 - 216	150	3
216 - 960	200	3
Above 960	500	3

Note:

- For Above 1000 MHz, the emission limit in this paragraph is based on measurement instrumentation employing an average detector, measurement using instrumentation with a peak detector function, corresponding to 20dB above the maximum permitted average limit.
- For above 1000 MHz, limit field strength of harmonics: 54dBuV/m@3m (AV) and 74dBuV/m@3m (PK).

5.7.2 Test Setup

See section 4.5.3 to 4.5.5 for test setup description for the antenna port. The photo of test setup please refer to ANNEX B.

5.7.3 Test Procedure

Since the emission limits are specified in terms of radiated field strength levels, measurements performed to demonstrate compliance have traditionally relied on a radiated test configuration. Radiated measurements remain the principal method for demonstrating compliance to the specified limits; however antenna-port conducted measurements are also now acceptable to demonstrate compliance (see below for details). When radiated measurements are utilized, test site requirements and procedures for maximizing and measuring radiated emissions that are described in ANSI C63.10 shall be followed.

Antenna-port conducted measurements may also be used as an alternative to radiated measurements for demonstrating compliance in the restricted frequency bands. If conducted measurements are performed, then proper impedance matching must be ensured and an additional radiated test for cabinet/case spurious emissions is required.

General Procedure for conducted measurements in restricted bands

- a) Measure the conducted output power (in dBm) using the detector specified (see guidance regarding measurement procedures for determining quasi-peak, peak, and average conducted output power, respectively).
- b) Add the maximum transmit antenna gain (in dBi) to the measured output power level to determine the EIRP level (see guidance on determining the applicable antenna gain)
- c) Add the appropriate maximum ground reflection factor to the EIRP level (6 dB for frequencies ≤ 30 MHz, 4.7 dB for frequencies between 30 MHz and 1000 MHz, inclusive and 0 dB for frequencies > 1000 MHz).
- d) For devices with multiple antenna-ports, measure the power of each individual chain and sum the EIRP of all chains in linear terms (e.g., Watts, mW).
- e) Convert the resultant EIRP level to an equivalent electric field strength using the following relationship:

$$E = \text{EIRP} - 20\log D + 104.8$$

where:

E = electric field strength in dB μ V/m,

EIRP = equivalent isotropic radiated power in dBm

D = specified measurement distance in meters.

- f) Compare the resultant electric field strength level to the applicable limit.
- g) Perform radiated spurious emission test.

Quasi-Peak measurement procedure

The specifications for measurements using the CISPR quasi-peak detector can be found in Publication 16 of the International Special Committee on Radio Frequency Interference (CISPR) of the International Electrotechnical Commission.

As an alternative to CISPR quasi-peak measurement, compliance can be demonstrated to the applicable emission limits using a peak detector.

Peak power measurement procedure

Peak emission levels are measured by setting the instrument as follows:

- a) RBW = as specified in Table 1.
- b) VBW $\geq 3 \times$ RBW.
- c) Detector = Peak.
- d) Sweep time = auto.
- e) Trace mode = max hold.
- f) Allow sweeps to continue until the trace stabilizes. (Note that the required measurement time may be

longer for low duty cycle applications).

Table 1—RBW as a function of frequency

Frequency	RBW
9-150 kHz	200-300 Hz
0.15-30 MHz	9-10 kHz
30-1000 MHz	100-120 kHz
> 1000 MHz	1 MHz

If the peak-detected amplitude can be shown to comply with the average limit, then it is not necessary to perform a separate average measurement.

Trace averaging across on and off times of the EUT transmissions followed by duty cycle correction

If continuous transmission of the EUT (i.e., duty cycle ≥ 98 percent) cannot be achieved and the duty cycle is constant (i.e., duty cycle variations are less than ± 2 percent), then the following procedure shall be used:

- a) The EUT shall be configured to operate at the maximum achievable duty cycle.
- b) Measure the duty cycle, x , of the transmitter output signal as described in section 6.0.
- c) RBW = 1 MHz (unless otherwise specified).
- d) VBW $\geq 3 \times$ RBW.
- e) Detector = RMS, if $\text{span}/(\# \text{ of points in sweep}) \leq (\text{RBW}/2)$. Satisfying this condition may require increasing the number of points in the sweep or reducing the span. If this condition cannot be satisfied, then the detector mode shall be set to peak.
- f) Averaging type = power (i.e., RMS).
 - 1) As an alternative, the detector and averaging type may be set for linear voltage averaging.
 - 2) Some instruments require linear display mode in order to use linear voltage averaging. Log or dB averaging shall not be used.
- g) Sweep time = auto.
- h) Perform a trace average of at least 100 traces.
- i) A correction factor shall be added to the measurement results prior to comparing to the emission limit in order to compute the emission level that would have been measured had the test been performed at 100 percent duty cycle. The correction factor is computed as follows:
 - 1) If power averaging (RMS) mode was used in step f), then the applicable correction factor is $10 \log(1/x)$, where x is the duty cycle.
 - 2) If linear voltage averaging mode was used in step f), then the applicable correction factor is $20 \log(1/x)$, where x is the duty cycle.
 - 3) If a specific emission is demonstrated to be continuous (≥ 98 percent duty cycle) rather than turning on and off with the transmit cycle, then no duty cycle correction is required for that emission.

NOTE: Reduction of the measured emission amplitude levels to account for operational duty factor is not permitted. Compliance is based on emission levels occurring during transmission - not on an average across on and off times of the transmitter.

Determining the applicable transmit antenna gain

A conducted power measurement will determine the maximum output power associated with a restricted band emission; however, in order to determine the associated EIRP level, the gain of the transmitting antenna (in dBi) must be added to the measured output power (in dBm).

Since the out-of-band characteristics of the EUT transmit antenna will often be unknown, the use of a conservative antenna gain value is necessary. Thus, when determining the EIRP based on the measured conducted power, the upper bound on antenna gain for a device with a single RF output shall be selected as the maximum in-band gain of the antenna across all operating bands, or 2 dBi, whichever is greater. However, for devices that operate in multiple frequency bands while using the same transmit antenna, the highest gain of the antenna within the operating band nearest in frequency to the restricted band emission being measured may be used in lieu of the overall highest gain when the emission is at a frequency that is within 20 percent of the nearest band edge frequency, but in no case shall a value less than 2 dBi be used.

See KDB 662911 for guidance on calculating the additional array gain term when determining the effective antenna gain for a EUT with multiple outputs occupying the same or overlapping frequency ranges in the same band.

Radiated spurious emission test

An additional consideration when performing conducted measurements of restricted band emissions is that unwanted emissions radiating from the EUT cabinet, control circuits, power leads, or intermediate circuit elements will likely go undetected in a conducted measurement configuration. To address this concern, a radiated test shall be performed to ensure that emissions emanating from the EUT cabinet (rather than the antenna port) also comply with the applicable limits.

For these cabinet radiated spurious emission measurements the EUT transmit antenna may be replaced with a termination matching the nominal impedance of the antenna. Procedures for performing radiated measurements are specified in ANSI C63.10. All detected emissions shall comply with the applicable limits.

The measurement frequency range is from 30 MHz to the 10th harmonic of the fundamental frequency. The Turn Table is actuated to turn from 0° to 360°, and both horizontal and vertical polarizations of the Test Antenna are used to find the maximum radiated power. Mid channels on all channel bandwidth verified. Only the worst RB size/offset presented.

The power of the EUT transmitting frequency should be ignored.

All Spurious Emission tests were performed in X, Y, Z axis direction. And only the worst axis test condition was recorded in this test report.

Use the following spectrum analyzer settings:

Span = wide enough to fully capture the emission being measured

RBW = 1 MHz for $f \geq 1$ GHz, 100 kHz for $f < 1$ GHz

VBW \geq RBW

Sweep = auto

Detector function = peak

Trace = max hold

5.7.4 Test Result

Please refer to ANNEX A.6.

5.8 Band Edge (Restricted-band band-edge)

5.8.1 Limit

FCC §15.209&15.247(d)

Radiated emission outside the frequency band attenuation below the general limits specified in FCC section 15.209(a) is not required. In addition, radiated emissions which fall in the restricted bands, as defined in FCC section 15.205(a), must also comply with the radiated emission limits specified in FCC section 15.209(a).

5.8.2 Test Setup

See section 4.5.1 for test setup description for the antenna port. The photo of test setup please refer to ANNEX B.

5.8.3 Test Procedure

The measurement frequency range is from 9 kHz to the 10th harmonic of the fundamental frequency. The Turn Table is actuated to turn from 0° to 360°, and both horizontal and vertical polarizations of the Test Antenna are used to find the maximum radiated power. Mid channels on all channel bandwidth verified. Only the worst RB size/offset presented.

The power of the EUT transmitting frequency should be ignored.

All Spurious Emission tests were performed in X, Y, Z axis direction. And only the worst axis test condition was recorded in this test report.

Use the following spectrum analyzer settings:

Span = wide enough to fully capture the emission being measured

RBW = 1 MHz for $f \geq 1$ GHz, 100 kHz for $f < 1$ GHz

VBW \geq RBW

Sweep = auto

Detector function = peak

Trace = max hold

For measurement below 1GHz, If the emission level of the EUT measured by the peak detector is 3 dB lower than the applicable limit, the peak emission level will be reported, Otherwise, the emission measurement will be repeated using the quasi-peak detector and reported.

For transmitters operating above 1 GHz repeat the measurement with an average detector.

5.8.4 Test Result

Please refer to ANNEX A.7.

5.9 Power Spectral density (PSD)

5.9.1 Limit

FCC §15.247(e)

The same method of determining the conducted output power shall be used to determine the power spectral density. If a peak output power is measured, then a peak power spectral density measurement is required. If an average output power is measured, then an average power spectral density measurement should be used.

5.9.2 Test Setup

See section 4.5.1 for test setup description for the antenna port. The photo of test setup please refer to ANNEX B.

5.9.3 Test Procedure

Set analyzer center frequency to DTS channel center frequency.

Set the span to 1.5 times the DTS bandwidth.

Set the RBW to: $3 \text{ kHz} \leq \text{RBW} \leq 100 \text{ kHz}$.

Set the VBW $\geq 3 \text{ RBW}$.

Detector = peak.

Sweep time = auto couple.

Trace mode = max hold.

Allow trace to fully stabilize.

Use the peak marker function to determine the maximum amplitude level within the RBW.

If measured value exceeds limit, reduce RBW (no less than 3 kHz) and repeat.

5.9.4 Test Result

Please refer to ANNEX A.8.

ANNEX A TEST RESULT

A.1 Output Power

Duty Cycle

Test Mode	On Time (ms)	On+Off time (ms)	Duty Cycle
802.11b	8.175	8.700	93.97%
802.11g	1.355	1.865	72.65%
802.11n-20 MHz	1.269	1.733	73.23%
802.11n-40 MHz	0.631	1.135	55.58%

Main Antenna

Peak Power Test Data

802.11b Mode:

Channel	Measured Output Peak Power		Limit		Verdict
	dBm	mW	dBm	mW	
Low	22.57	180.72	30	1000	Pass
Middle	22.08	161.44			Pass
High	21.78	150.66			Pass

802.11g Mode:

Channel	Measured Output Peak Power		Limit		Verdict
	dBm	mW	dBm	mW	
Low	23.26	211.84	30	1000	Pass
Middle	23.13	205.59			Pass
High	22.75	188.36			Pass

802.11n-20 MHz Mode:

Channel	Measured Output Peak Power		Limit		Verdict
	dBm	mW	dBm	mW	
Low	22.71	186.64	30	1000	Pass
Middle	22.19	165.58			Pass
High	22.94	196.79			Pass

802.11n-40 MHz Mode:

Channel	Measured Output Peak Power		Limit		Verdict
	dBm	mW	dBm	mW	
Low	14.88	17.43	30	1000	Pass
Middle	15.61	18.16			Pass
High	14.01	16.56			Pass

Average Power Test Data

802.11b Mode:

Channel	Measured Output Average Power		Limit		Verdict
	dBm	mW	dBm	mW	
Low	19.79	95.28	30	1000	Pass
Middle	19.73	93.97			Pass
High	19.06	80.54			Pass

802.11g Mode:

Channel	Measured Output Average Power		Limit		Verdict
	dBm	mW	dBm	mW	
Low	18.60	72.44	30	1000	Pass
Middle	18.62	72.78			Pass
High	17.64	58.08			Pass

802.11n-20 MHz Mode:

Channel	Measured Output Average Power		Limit		Verdict
	dBm	mW	dBm	mW	
Low	17.14	51.76	30	1000	Pass
Middle	17.37	54.58			Pass
High	16.62	45.92			Pass

802.11n-40 MHz Mode:

Channel	Measured Output Average Power		Limit		Verdict
	dBm	mW	dBm	mW	
Low	17.43	55.34	30	1000	Pass
Middle	18.16	65.46			Pass
High	16.56	45.29			Pass

Aux. AntennaPeak Power Test Data

802.11b Mode:

Channel	Measured Output Peak Power		Limit		Verdict
	dBm	mW	dBm	mW	
Low	22.35	171.79	30	1000	Pass
Middle	21.12	129.42			Pass
High	20.97	125.03			Pass

802.11g Mode:

Channel	Measured Output Peak Power		Limit		Verdict
	dBm	mW	dBm	mW	
Low	23.26	211.84	30	1000	Pass
Middle	22.61	182.39			Pass
High	22.02	159.22			Pass

802.11n-20 MHz Mode:

Channel	Measured Output Peak Power		Limit		Verdict
	dBm	mW	dBm	mW	
Low	22.86	193.20	30	1000	Pass
Middle	22.24	167.49			Pass
High	22.03	159.59			Pass

802.11n-40 MHz Mode:

Channel	Measured Output Peak Power		Limit		Verdict
	dBm	mW	dBm	mW	
Low	20.41	109.90	30	1000	Pass
Middle	22.37	172.58			Pass
High	21.57	143.55			Pass

Average Power Test Data

802.11b Mode:

Channel	Measured Output Average Power		Limit		Verdict
	dBm	mW	dBm	mW	
Low	17.94	62.23	30	1000	Pass
Middle	19.12	81.66			Pass
High	18.42	69.50			Pass

802.11g Mode:

Channel	Measured Output Average Power		Limit		Verdict
	dBm	mW	dBm	mW	
Low	18.17	65.61	30	1000	Pass
Middle	18.02	63.39			Pass
High	17.57	57.15			Pass

802.11n-20 MHz Mode:

Channel	Measured Output Average Power		Limit		Verdict
	dBm	mW	dBm	mW	
Low	18.00	63.10	30	1000	Pass
Middle	17.73	59.29			Pass
High	17.09	51.17			Pass

802.11n-40 MHz Mode:

Channel	Measured Output Average Power		Limit		Verdict
	dBm	mW	dBm	mW	
Low	16.00	39.81	30	1000	Pass
Middle	18.80	75.86			Pass
High	17.26	53.21			Pass

MIMO-Main AntennaPeak Power Test Data

802.11n-20 MHz Mode:

Channel	Measured Output Peak Power		Limit		Verdict
	dBm	mW	dBm	mW	
Low	18.95	78.52	30	1000	Pass
Middle	18.22	66.37			Pass
High	17.37	54.58			Pass

802.11n-40 MHz Mode:

Channel	Measured Output Peak Power		Limit		Verdict
	dBm	mW	dBm	mW	
Low	15.72	37.33	30	1000	Pass
Middle	15.76	37.67			Pass
High	14.72	29.65			Pass

Average Power Test Data

802.11n-20 MHz Mode:

Channel	Measured Output Average Power		Limit		Verdict
	dBm	mW	dBm	mW	
Low	13.40	21.88	30	1000	Pass
Middle	13.22	20.99			Pass
High	12.26	16.83			Pass

802.11n-40 MHz Mode:

Channel	Measured Output Average Power		Limit		Verdict
	dBm	mW	dBm	mW	
Low	11.22	13.24	30	1000	Pass
Middle	11.26	13.37			Pass
High	10.36	10.86			Pass

MIMO-Aux. AntennaPeak Power Test Data

802.11n-20 MHz Mode:

Channel	Measured Output Peak Power		Limit		Verdict
	dBm	mW	dBm	mW	
Low	17.89	61.52	30	1000	Pass
Middle	17.93	62.09			Pass
High	16.72	46.99			Pass

802.11n-40 MHz Mode:

Channel	Measured Output Peak Power		Limit		Verdict
	dBm	mW	dBm	mW	
Low	14.74	29.79	30	1000	Pass
Middle	13.93	24.72			Pass
High	13.91	24.60			Pass

Average Power Test Data

802.11n-20 MHz Mode:

Channel	Measured Output Average Power		Limit		Verdict
	dBm	mW	dBm	mW	
Low	12.02	15.92	30	1000	Pass
Middle	11.86	15.35			Pass
High	11.18	13.12			Pass

802.11n-40 MHz Mode:

Channel	Measured Output Average Power		Limit		Verdict
	dBm	mW	dBm	mW	
Low	9.61	9.14	30	1000	Pass
Middle	9.56	9.04			Pass
High	8.46	7.01			Pass

MIMOPeak Power Test Data

802.11n-20 MHz Mode:

Channel	Measured Output Peak Power		Limit		Verdict
	dBm	mW	dBm	mW	
Low	21.46	140.04	30	1000	Pass
Middle	21.09	128.46			Pass
High	20.07	101.57			Pass

802.11n-40 MHz Mode:

Channel	Measured Output Peak Power		Limit		Verdict
	dBm	mW	dBm	mW	
Low	18.27	67.11	30	1000	Pass
Middle	17.95	62.39			Pass
High	17.34	54.25			Pass

Average Power Test Data

802.11n-20 MHz Mode:

Channel	Measured Output Average Power		Limit		Verdict
	dBm	mW	dBm	mW	
Low	15.77	37.80	30	1000	Pass
Middle	15.60	36.34			Pass
High	14.76	29.95			Pass

802.11n-40 MHz Mode:

Channel	Measured Output Average Power		Limit		Verdict
	dBm	mW	dBm	mW	
Low	13.50	22.38	30	1000	Pass
Middle	13.50	22.40			Pass
High	12.52	17.88			Pass

A.2 Occupied Bandwidth

Note: The Occupied Bandwidth please refer to report: BL-EC19A0003-603, which was issued by Shenzhen BALUN Technology Co., Ltd. on Dec. 12, 2019, **section A.2 Occupied Bandwidth**.

A.3 Conducted Spurious Emissions

Note: The Conducted Spurious Emission please refer to report: BL-EC19A0003-603, which was issued by Shenzhen BALUN Technology Co., Ltd. on Dec. 12, 2019, **section A.3 Conducted Spurious Emissions**.

A.4 Band Edge (Authorized-band band-edge)

Note: Note: Band Edge (Authorized-band band-edge) please refer to report: BL-EC19A0003-603, which was issued by Shenzhen BALUN Technology Co., Ltd. on Dec. 12, 2019, **section A.4 Band Edge (Authorized-band band-edge)**.

A.5 Conducted Emissions

Note ¹: The EUT is working in the Normal link mode. All modes have been tested and normal link mode is worst.

Test Data and Plots

PHASE L

CE Test case_FCC_CE_FCC PART 15B_Class B

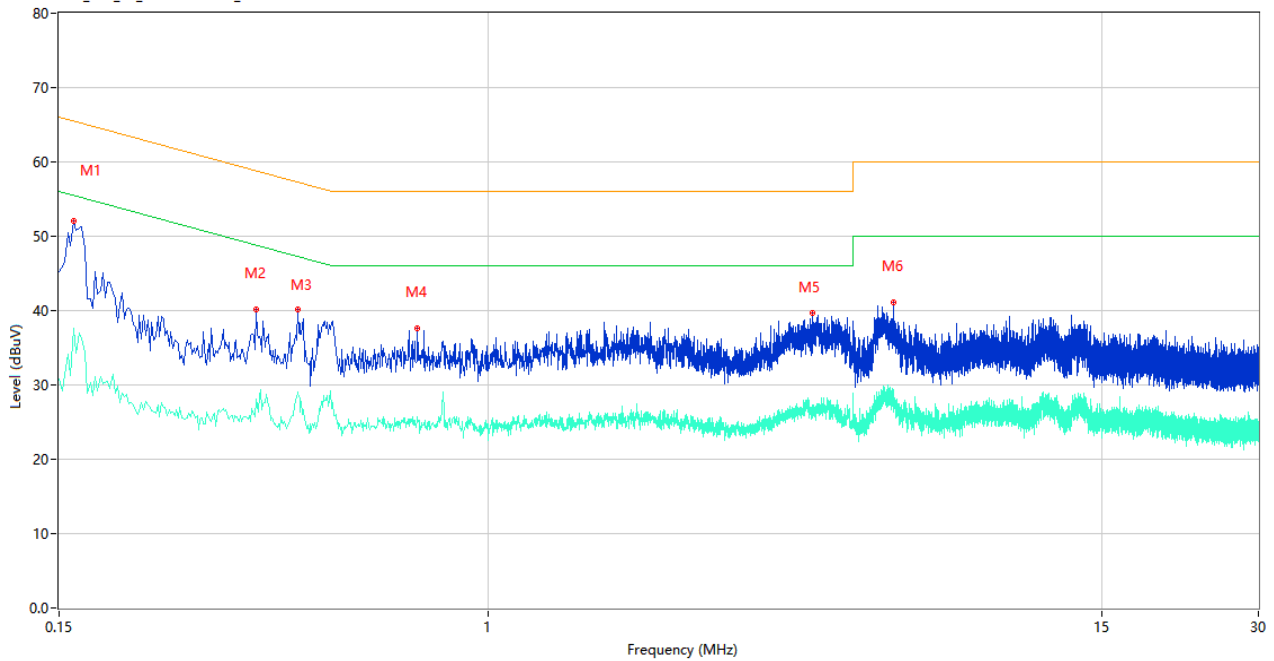

No.	Frequency (MHz)	Results (dBuV)	Factor (dB)	Limit (dBuV)	Margin (dB)	Detector	Line	Verdict
1	0.160	52.09	10.08	65.46	13.37	Peak	L	Pass
1**	0.160	37.58	10.08	55.46	17.88	AV	L	Pass
2	0.358	40.15	10.94	58.77	18.62	Peak	L	Pass
2**	0.358	28.10	10.94	48.77	20.67	AV	L	Pass
3	0.430	40.15	10.44	57.25	17.10	Peak	L	Pass
3**	0.430	28.99	10.44	47.25	18.26	AV	L	Pass
4	0.730	37.60	10.52	56.00	18.40	Peak	L	Pass
4**	0.730	25.66	10.52	46.00	20.34	AV	L	Pass
5	4.186	39.66	10.16	56.00	16.34	Peak	L	Pass
5**	4.186	27.13	10.16	46.00	18.87	AV	L	Pass
6	5.990	41.16	10.34	60.00	18.84	Peak	L	Pass
6**	5.990	29.20	10.34	50.00	20.80	AV	L	Pass

PHASE N

CE Test case_FCC_CE_FCC PART 15B_Class B

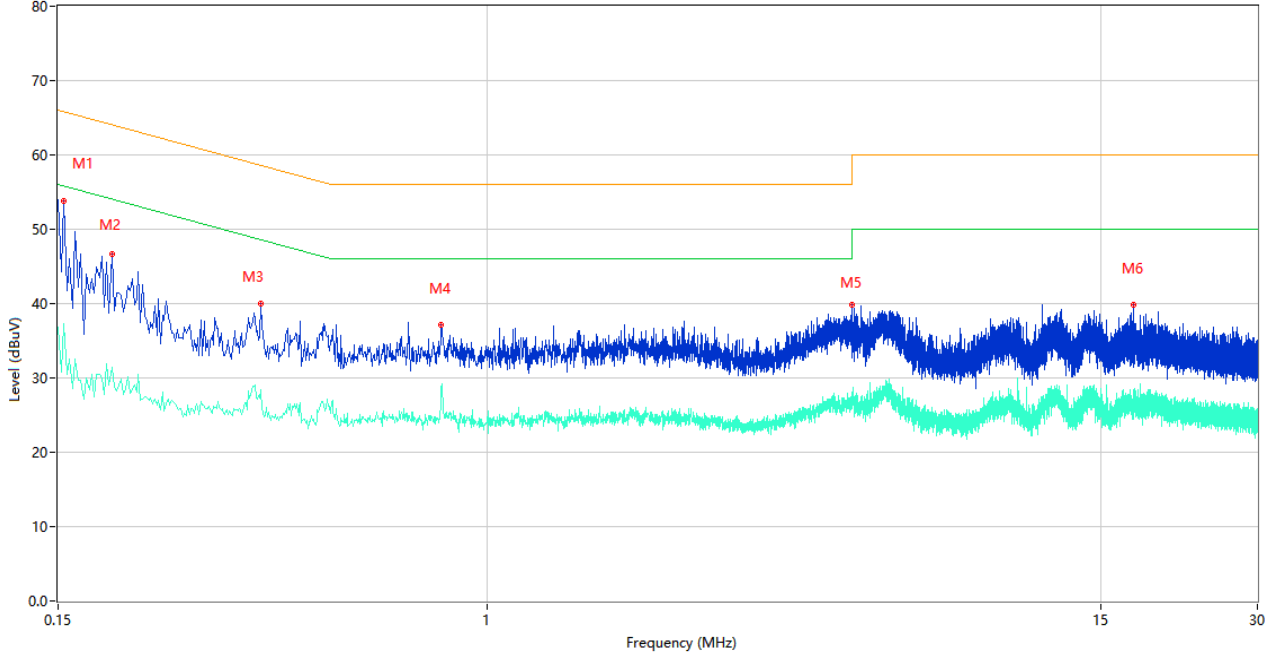

No.	Frequency (MHz)	Results (dBuV)	Factor (dB)	Limit (dBuV)	Margin (dB)	Detector	Line	Verdict
1	0.154	53.78	10.09	65.78	12.00	Peak	N	Pass
1**	0.154	37.35	10.09	55.78	18.43	AV	N	Pass
2	0.190	46.61	10.06	64.04	17.43	Peak	N	Pass
2**	0.190	31.47	10.06	54.04	22.57	AV	N	Pass
3	0.368	40.07	10.89	58.55	18.48	Peak	N	Pass
3**	0.368	28.41	10.89	48.55	20.14	AV	N	Pass
4	0.816	37.09	10.70	56.00	18.91	Peak	N	Pass
4**	0.816	28.78	10.70	46.00	17.22	AV	N	Pass
5	5.016	39.87	10.41	60.00	20.13	Peak	N	Pass
5**	5.016	27.24	10.41	50.00	22.76	AV	N	Pass
6	17.370	39.78	10.46	60.00	20.22	Peak	N	Pass
6**	17.370	26.33	10.46	50.00	23.67	AV	N	Pass

A.6 Radiated Emission

Note ¹: The symbol of "--" in the table which means not application.

Note ²: For the test data above 1 GHz, According the ANSI C63.10-2013, where limits are specified for both average and peak (or quasi-peak) detector functions, if the peak (or quasi-peak) measured value complies with the average limit, it is unnecessary to perform an average measurement.

Note ³: The low frequency, which started from 9 kHz to 30 MHz, was pre-scanned and the result which was 20 dB lower than the limit line per 15.31(o) was not reported.

Note ⁴: The EUT is working in the Normal link mode below 1 GHz. All modes have been tested and normal link mode is worst.

Test Data and Plots

30 MHz to 1 GHz, ANT H

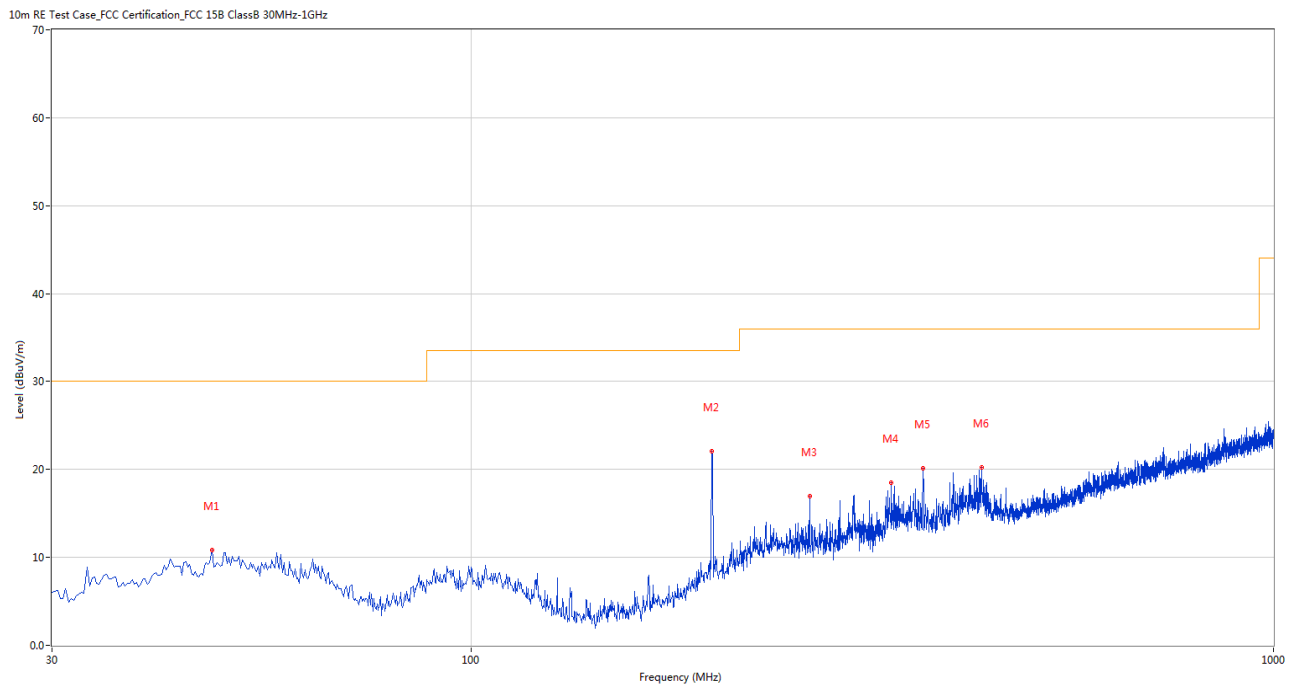

No.	Frequency (MHz)	Results (dBuV/m)	Factor (dB)	Limit (dBuV/m)	Margin (dB)	Detector	Table (Degree)	Height (cm)	Antenna	Verdict
1	47.456	10.80	-26.37	30.0	19.20	Peak	87.00	200	Horizontal	Pass
2	199.223	22.09	-27.79	33.5	11.41	Peak	211.00	200	Horizontal	Pass
3	263.954	16.98	-25.82	36.0	19.02	Peak	177.00	200	Horizontal	Pass
4	334.019	18.49	-24.04	36.0	17.51	Peak	316.00	200	Horizontal	Pass
5	365.294	20.17	-23.61	36.0	15.83	Peak	152.00	200	Horizontal	Pass
6	432.692	20.26	-21.92	36.0	15.74	Peak	257.00	200	Horizontal	Pass

30 MHz to 1 GHz, ANT V

10m RE Test Case_FCC Certification_FCC 15B ClassB 30MHz-1GHz

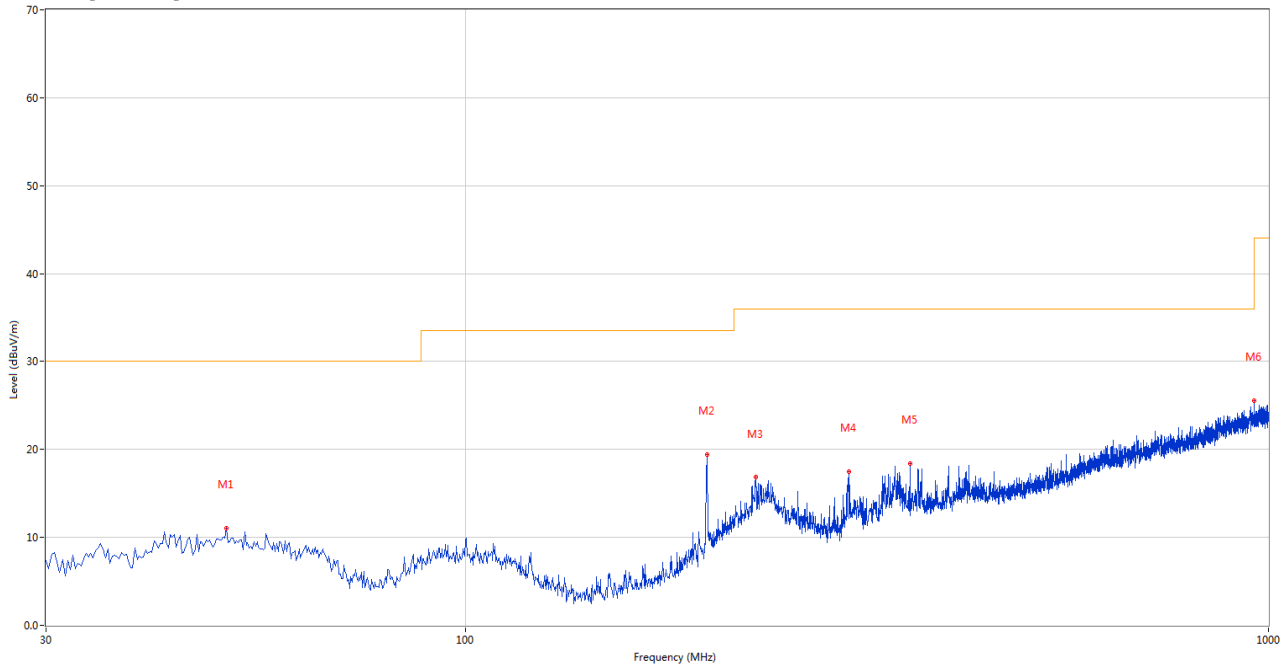

No.	Frequency (MHz)	Results (dBuV/m)	Factor (dB)	Limit (dBuV/m)	Margin (dB)	Detector	Table (Degree)	Height (cm)	Antenna	Verdict
1	50.365	11.02	-26.23	30.0	18.98	Peak	195.00	100	Vertical	Pass
2	199.950	19.41	-27.78	33.5	14.09	Peak	0.00	200	Vertical	Pass
3	229.770	16.81	-26.86	36.0	19.19	Peak	341.00	100	Vertical	Pass
4	299.835	17.47	-25.15	36.0	18.53	Peak	358.00	100	Vertical	Pass
5	358.020	18.41	-23.34	36.0	17.59	Peak	0.00	200	Vertical	Pass
6	959.270	25.58	-12.09	36.0	10.42	Peak	137.00	200	Vertical	Pass

Note 1: The marked spikes near 2400 MHz with circle should be ignored because they are Fundamental signal.

Note 2: The spurious above 18G is noise only, do not show on the report.

Main Antenna

1 GHz to 18 GHz, ANT H 802.11b Low Channel

No.	Frequency (MHz)	Results (dBuV/m)	Factor (dB)	Limit (dBuV/m)	Margin (dB)	Detector	Table (Degree)	Height (cm)	Antenna	Verdict
1	2331.700	49.36	-14.31	74.0	24.64	Peak	360.00	200	Horizontal	Pass
1**	2331.700	41.74	-14.31	54.0	12.26	AV	360.00	200	Horizontal	Pass
2	2410.600	103.37	-15.19	74.0	-29.37	Peak	170.00	100	Horizontal	N/A
2**	2410.600	100.42	-15.19	54.0	-46.42	AV	170.00	100	Horizontal	N/A
3	2571.700	50.80	-13.19	74.0	23.20	Peak	328.00	100	Horizontal	Pass
3**	2571.700	42.85	-13.19	54.0	11.15	AV	328.00	100	Horizontal	Pass
4	7361.500	52.39	-0.36	74.0	21.61	Peak	87.00	300	Horizontal	Pass
4**	7361.500	44.16	-0.36	54.0	9.84	AV	87.00	300	Horizontal	Pass
5	12765.000	44.87	1.68	74.0	29.13	Peak	55.00	100	Horizontal	Pass
5**	12765.000	38.21	1.68	54.0	15.79	AV	55.00	100	Horizontal	Pass
6	17562.499	47.30	6.34	74.0	26.70	Peak	37.00	200	Horizontal	Pass
6**	17562.499	39.87	6.34	54.0	14.13	AV	37.00	200	Horizontal	Pass

1 GHz to 18 GHz, ANT V 802.11b Low Channel

No.	Frequency (MHz)	Results (dBuV/m)	Factor (dB)	Limit (dBuV/m)	Margin (dB)	Detector	Table (Degree)	Height (cm)	Antenna	Verdict
1	1522.100	40.26	-19.21	74.0	33.74	Peak	323.00	100	Vertical	Pass
1**	1522.100	30.58	-19.21	54.0	23.42	AV	323.00	100	Vertical	Pass
2	2412.000	92.66	-14.99	74.0	-18.66	Peak	148.00	100	Vertical	N/A
2**	2412.000	86.70	-14.99	54.0	-32.70	AV	148.00	100	Vertical	N/A
3	2785.100	50.61	-9.97	74.0	23.39	Peak	164.00	200	Vertical	Pass
3**	2785.100	41.07	-9.97	54.0	12.93	AV	164.00	200	Vertical	Pass
4	4870.250	49.26	-6.08	74.0	24.74	Peak	16.00	200	Vertical	Pass
4**	4870.250	38.36	-6.08	54.0	15.64	AV	16.00	200	Vertical	Pass
5	7222.000	52.82	-1.74	74.0	21.18	Peak	240.00	300	Vertical	Pass
5**	7222.000	42.83	-1.74	54.0	11.17	AV	240.00	300	Vertical	Pass
6	17789.999	48.99	6.22	74.0	25.01	Peak	299.00	100	Vertical	Pass
6**	17789.999	41.31	6.22	54.0	12.69	AV	299.00	100	Vertical	Pass

1 GHz to 18 GHz, ANT H 802.11b Middle Channel

No.	Frequency (MHz)	Results (dBuV/m)	Factor (dB)	Limit (dBuV/m)	Margin (dB)	Detector	Table (Degree)	Height (cm)	Antenna	Verdict
1	1416.700	40.23	-18.96	74.0	33.77	Peak	241.00	200	Horizontal	Pass
1**	1416.700	30.74	-18.96	54.0	23.26	AV	241.00	200	Horizontal	Pass
2	2438.800	103.98	-14.30	74.0	-29.98	Peak	160.00	150	Horizontal	N/A
2**	2438.800	101.10	-14.30	54.0	-47.10	AV	160.00	150	Horizontal	N/A
3	2595.000	49.73	-13.40	74.0	24.27	Peak	322.00	200	Horizontal	Pass
3**	2595.000	42.41	-13.40	54.0	11.59	AV	322.00	200	Horizontal	Pass
4	7574.000	53.00	-1.21	74.0	21.00	Peak	314.00	100	Horizontal	Pass
4**	7574.000	42.96	-1.21	54.0	11.04	AV	314.00	100	Horizontal	Pass
5	12760.001	45.60	1.63	74.0	28.40	Peak	352.00	400	Horizontal	Pass
5**	12760.001	37.90	1.63	54.0	16.10	AV	352.00	400	Horizontal	Pass
6	17830.001	47.65	5.71	74.0	26.35	Peak	154.00	300	Horizontal	Pass
6**	17830.001	39.51	5.71	54.0	14.49	AV	154.00	300	Horizontal	Pass

1 GHz to 18 GHz, ANT V 802.11b Middle Channel

No.	Frequency (MHz)	Results (dBuV/m)	Factor (dB)	Limit (dBuV/m)	Margin (dB)	Detector	Table (Degree)	Height (cm)	Antenna	Verdict
1	1414.200	39.87	-19.31	74.0	34.13	Peak	337.00	200	Vertical	Pass
1**	1414.200	30.56	-19.31	54.0	23.44	AV	337.00	200	Vertical	Pass
2	2437.000	91.27	-14.63	74.0	-17.27	Peak	285.00	100	Vertical	N/A
2**	2437.000	84.92	-14.63	54.0	-30.92	AV	285.00	100	Vertical	N/A
3	2777.000	50.17	-10.34	74.0	23.83	Peak	0.00	100	Vertical	Pass
3**	2777.000	40.85	-10.34	54.0	13.15	AV	0.00	100	Vertical	Pass
4	6842.000	52.69	-2.64	74.0	21.31	Peak	18.00	400	Vertical	Pass
4**	6842.000	41.62	-2.64	54.0	12.38	AV	18.00	400	Vertical	Pass
5	12792.500	46.40	1.94	74.0	27.60	Peak	75.00	100	Vertical	Pass
5**	12792.500	37.88	1.94	54.0	16.12	AV	75.00	100	Vertical	Pass
6	17820.000	48.58	5.98	74.0	25.42	Peak	136.00	400	Vertical	Pass
6**	17820.000	39.89	5.98	54.0	14.11	AV	136.00	400	Vertical	Pass

1 GHz to 18 GHz, ANT H 802.11b High Channel

No.	Frequency (MHz)	Results (dBuV/m)	Factor (dB)	Limit (dBuV/m)	Margin (dB)	Detector	Table (Degree)	Height (cm)	Antenna	Verdict
1	2299.200	47.81	-14.90	74.0	26.19	Peak	338.00	100	Horizontal	Pass
1**	2299.200	41.27	-14.90	54.0	12.73	AV	338.00	100	Horizontal	Pass
2	2460.800	104.37	-13.69	74.0	-30.37	Peak	164.00	150	Horizontal	N/A
2**	2460.800	101.44	-13.69	54.0	-47.44	AV	164.00	150	Horizontal	N/A
3	2625.300	49.78	-14.00	74.0	24.22	Peak	181.00	200	Horizontal	Pass
3**	2625.300	42.01	-14.00	54.0	11.99	AV	181.00	200	Horizontal	Pass
4	7334.750	52.66	-0.97	74.0	21.34	Peak	253.00	300	Horizontal	Pass
4**	7334.750	44.32	-0.97	54.0	9.68	AV	253.00	300	Horizontal	Pass
5	12757.500	44.75	1.61	74.0	29.25	Peak	8.00	300	Horizontal	Pass
5**	12757.500	37.65	1.61	54.0	16.35	AV	8.00	300	Horizontal	Pass
6	17802.500	48.15	6.46	74.0	25.85	Peak	174.00	200	Horizontal	Pass
6**	17802.500	41.13	6.46	54.0	12.87	AV	174.00	200	Horizontal	Pass

1 GHz to 18 GHz, ANT V 802.11b High Channel

No.	Frequency (MHz)	Results (dBuV/m)	Factor (dB)	Limit (dBuV/m)	Margin (dB)	Detector	Table (Degree)	Height (cm)	Antenna	Verdict
1	1461.400	40.30	-19.28	74.0	33.70	Peak	340.00	100	Vertical	Pass
1**	1461.400	31.17	-19.28	54.0	22.83	AV	340.00	100	Vertical	Pass
2	2462.000	93.46	-14.13	74.0	-19.46	Peak	149.00	100	Vertical	N/A
2**	2462.000	88.05	-14.13	54.0	-34.05	AV	149.00	100	Vertical	N/A
3	2785.900	50.20	-10.07	74.0	23.80	Peak	105.00	150	Vertical	Pass
3**	2785.900	40.99	-10.07	54.0	13.01	AV	105.00	150	Vertical	Pass
4	7995.250	52.79	0.13	74.0	21.21	Peak	360.00	200	Vertical	Pass
4**	7995.250	43.28	0.13	54.0	10.72	AV	360.00	200	Vertical	Pass
5	12792.500	45.32	1.94	74.0	28.68	Peak	207.00	400	Vertical	Pass
5**	12792.500	37.89	1.94	54.0	16.11	AV	207.00	400	Vertical	Pass
6	17795.000	47.75	6.37	74.0	26.25	Peak	74.00	100	Vertical	Pass
6**	17795.000	40.64	6.37	54.0	13.36	AV	74.00	100	Vertical	Pass

1 GHz to 18 GHz, ANT H 802.11g Low Channel

No.	Frequency (MHz)	Results (dBuV/m)	Factor (dB)	Limit (dBuV/m)	Margin (dB)	Detector	Table (Degree)	Height (cm)	Antenna	Verdict
1	2252.000	47.14	-14.05	74.0	26.86	Peak	322.00	300	Horizontal	Pass
1**	2252.000	39.98	-14.05	54.0	14.02	AV	322.00	300	Horizontal	Pass
2	2411.100	105.54	-14.85	74.0	-31.54	Peak	164.00	150	Horizontal	N/A
2**	2411.100	98.12	-14.85	54.0	-44.12	AV	164.00	150	Horizontal	N/A
3	2568.400	50.96	-12.99	74.0	23.04	Peak	360.00	100	Horizontal	Pass
3**	2568.400	41.16	-12.99	54.0	12.84	AV	360.00	100	Horizontal	Pass
4	7989.250	53.06	0.44	74.0	20.94	Peak	110.00	200	Horizontal	Pass
4**	7989.250	43.80	0.44	54.0	10.20	AV	110.00	200	Horizontal	Pass
5	12390.000	44.99	0.39	74.0	29.01	Peak	42.00	400	Horizontal	Pass
5**	12390.000	35.95	0.39	54.0	18.05	AV	42.00	400	Horizontal	Pass
6	17827.500	49.20	5.78	74.0	24.80	Peak	122.00	100	Horizontal	Pass
6**	17827.500	40.50	5.78	54.0	13.50	AV	122.00	100	Horizontal	Pass

1 GHz to 18 GHz, ANT V 802.11g Low Channel

No.	Frequency (MHz)	Results (dBuV/m)	Factor (dB)	Limit (dBuV/m)	Margin (dB)	Detector	Table (Degree)	Height (cm)	Antenna	Verdict
1	1315.800	40.58	-19.01	74.0	33.42	Peak	252.00	200	Vertical	Pass
1**	1315.800	31.42	-19.01	54.0	22.58	AV	252.00	200	Vertical	Pass
2	2413.400	93.88	-14.75	74.0	-19.88	Peak	156.00	200	Vertical	N/A
2**	2413.400	86.04	-14.75	54.0	-32.04	AV	156.00	200	Vertical	N/A
3	2786.300	49.96	-9.93	74.0	24.04	Peak	86.00	200	Vertical	Pass
3**	2786.300	42.31	-9.93	54.0	11.69	AV	86.00	200	Vertical	Pass
4	7357.250	52.71	-1.18	74.0	21.29	Peak	292.00	100	Vertical	Pass
4**	7357.250	43.99	-1.18	54.0	10.01	AV	292.00	100	Vertical	Pass
5	12765.000	45.69	1.68	74.0	28.31	Peak	259.00	100	Vertical	Pass
5**	12765.000	37.80	1.68	54.0	16.20	AV	259.00	100	Vertical	Pass
6	17542.500	48.55	6.36	74.0	25.45	Peak	15.00	400	Vertical	Pass
6**	17542.500	40.44	6.36	54.0	13.56	AV	15.00	400	Vertical	Pass

1 GHz to 18 GHz, ANT H 802.11g Middle Channel

No.	Frequency (MHz)	Results (dBuV/m)	Factor (dB)	Limit (dBuV/m)	Margin (dB)	Detector	Table (Degree)	Height (cm)	Antenna	Verdict
1	1436.900	40.38	-19.60	74.0	33.62	Peak	260.00	100	Horizontal	Pass
1**	1436.900	30.93	-19.60	54.0	23.07	AV	260.00	100	Horizontal	Pass
2	2439.600	105.29	-15.08	74.0	-31.29	Peak	172.00	150	Horizontal	N/A
2**	2439.600	97.86	-15.08	54.0	-43.86	AV	172.00	150	Horizontal	N/A
3	2594.900	49.54	-13.50	74.0	24.46	Peak	331.00	100	Horizontal	Pass
3**	2594.900	40.80	-13.50	54.0	13.20	AV	331.00	100	Horizontal	Pass
4	7570.500	53.10	-0.94	74.0	20.90	Peak	214.00	400	Horizontal	Pass
4**	7570.500	43.32	-0.94	54.0	10.68	AV	214.00	400	Horizontal	Pass
5	12812.500	45.36	1.63	74.0	28.64	Peak	11.00	300	Horizontal	Pass
5**	12812.500	37.05	1.63	54.0	16.95	AV	11.00	300	Horizontal	Pass
6	17785.000	49.33	6.07	74.0	24.67	Peak	35.00	400	Horizontal	Pass
6**	17785.000	42.28	6.07	54.0	11.72	AV	35.00	400	Horizontal	Pass

1 GHz to 18 GHz, ANT V 802.11g Middle Channel

No.	Frequency (MHz)	Results (dBuV/m)	Factor (dB)	Limit (dBuV/m)	Margin (dB)	Detector	Table (Degree)	Height (cm)	Antenna	Verdict
1	1497.300	39.75	-18.79	74.0	34.25	Peak	20.00	400	Vertical	Pass
1**	1497.300	30.66	-18.79	54.0	23.34	AV	20.00	400	Vertical	Pass
2	2435.200	91.96	-14.95	74.0	-17.96	Peak	274.00	150	Vertical	N/A
2**	2435.200	84.47	-14.95	54.0	-30.47	AV	274.00	150	Vertical	N/A
3	2783.000	50.31	-9.46	74.0	23.69	Peak	213.00	200	Vertical	Pass
3**	2783.000	41.57	-9.46	54.0	12.43	AV	213.00	200	Vertical	Pass
4	7587.750	52.97	-0.44	74.0	21.03	Peak	146.00	400	Vertical	Pass
4**	7587.750	43.81	-0.44	54.0	10.19	AV	146.00	400	Vertical	Pass
5	12797.500	45.34	1.99	74.0	28.66	Peak	311.00	100	Vertical	Pass
5**	12797.500	37.96	1.99	54.0	16.04	AV	311.00	100	Vertical	Pass
6	17792.500	48.62	6.30	74.0	25.38	Peak	311.00	200	Vertical	Pass
6**	17792.500	40.07	6.30	54.0	13.93	AV	311.00	200	Vertical	Pass

1 GHz to 18 GHz, ANT H 802.11g High Channel

No.	Frequency (MHz)	Results (dBuV/m)	Factor (dB)	Limit (dBuV/m)	Margin (dB)	Detector	Table (Degree)	Height (cm)	Antenna	Verdict
1	2383.300	49.73	-14.70	74.0	24.27	Peak	164.00	300	Horizontal	Pass
1**	2383.300	39.91	-14.70	54.0	14.09	AV	164.00	300	Horizontal	Pass
2	2457.200	105.89	-13.22	74.0	-31.89	Peak	164.00	150	Horizontal	N/A
2**	2457.200	98.76	-13.22	54.0	-44.76	AV	164.00	150	Horizontal	N/A
3	2618.400	50.05	-13.66	74.0	23.95	Peak	164.00	200	Horizontal	Pass
3**	2618.400	41.78	-13.66	54.0	12.22	AV	164.00	200	Horizontal	Pass
4	7761.250	53.00	-0.48	74.0	21.00	Peak	117.00	400	Horizontal	Pass
4**	7761.250	44.80	-0.48	54.0	9.20	AV	117.00	400	Horizontal	Pass
5	12785.000	45.17	1.87	74.0	28.83	Peak	315.00	200	Horizontal	Pass
5**	12785.000	37.11	1.87	54.0	16.89	AV	315.00	200	Horizontal	Pass
6	17805.001	48.84	6.39	74.0	25.16	Peak	231.00	100	Horizontal	Pass
6**	17805.001	40.28	6.39	54.0	13.72	AV	231.00	100	Horizontal	Pass

1 GHz to 18 GHz, ANT V 802.11g High Channel

No.	Frequency (MHz)	Results (dBuV/m)	Factor (dB)	Limit (dBuV/m)	Margin (dB)	Detector	Table (Degree)	Height (cm)	Antenna	Verdict
1	1475.300	40.31	-19.27	74.0	33.69	Peak	110.00	200	Vertical	Pass
1**	1475.300	30.87	-19.27	54.0	23.13	AV	110.00	200	Vertical	Pass
2	2459.100	95.29	-13.59	74.0	-21.29	Peak	153.00	200	Vertical	N/A
2**	2459.100	88.02	-13.59	54.0	-34.02	AV	153.00	200	Vertical	N/A
3	2784.900	50.91	-9.85	74.0	23.09	Peak	251.00	150	Vertical	Pass
3**	2784.900	41.35	-9.85	54.0	12.65	AV	251.00	150	Vertical	Pass
4	7770.750	53.24	-1.05	74.0	20.76	Peak	285.00	300	Vertical	Pass
4**	7770.750	42.68	-1.05	54.0	11.32	AV	285.00	300	Vertical	Pass
5	12755.000	45.92	1.58	74.0	28.08	Peak	78.00	300	Vertical	Pass
5**	12755.000	38.42	1.58	54.0	15.58	AV	78.00	300	Vertical	Pass
6	17579.999	47.43	6.11	74.0	26.57	Peak	322.00	200	Vertical	Pass
6**	17579.999	39.73	6.11	54.0	14.27	AV	322.00	200	Vertical	Pass

1 GHz to 18 GHz, ANT H 802.11n20 Low Channel

No.	Frequency (MHz)	Results (dBuV/m)	Factor (dB)	Limit (dBuV/m)	Margin (dB)	Detector	Table (Degree)	Height (cm)	Antenna	Verdict
1	2332.100	49.09	-14.96	74.0	24.91	Peak	174.00	100	Horizontal	Pass
1**	2332.100	42.75	-14.96	54.0	11.25	AV	174.00	100	Horizontal	Pass
2	2411.000	103.45	-14.96	74.0	-29.45	Peak	164.00	200	Horizontal	N/A
2**	2411.000	95.73	-14.96	54.0	-41.73	AV	164.00	200	Horizontal	N/A
3	2492.200	51.08	-13.77	74.0	22.92	Peak	164.00	100	Horizontal	Pass
3**	2492.200	44.27	-13.77	54.0	9.73	AV	164.00	100	Horizontal	Pass
4	7571.250	53.06	-0.79	74.0	20.94	Peak	0.00	200	Horizontal	Pass
4**	7571.250	43.53	-0.79	54.0	10.47	AV	0.00	200	Horizontal	Pass
5	12740.000	46.11	1.33	74.0	27.89	Peak	16.00	400	Horizontal	Pass
5**	12740.000	36.75	1.33	54.0	17.25	AV	16.00	400	Horizontal	Pass
6	17799.999	47.82	6.52	74.0	26.18	Peak	296.00	200	Horizontal	Pass
6**	17799.999	40.11	6.52	54.0	13.89	AV	296.00	200	Horizontal	Pass

1 GHz to 18 GHz, ANT V 802.11n20 Low Channel

No.	Frequency (MHz)	Results (dBuV/m)	Factor (dB)	Limit (dBuV/m)	Margin (dB)	Detector	Table (Degree)	Height (cm)	Antenna	Verdict
1	1329.700	40.53	-19.80	74.0	33.47	Peak	119.00	100	Vertical	Pass
1**	1329.700	32.74	-19.80	54.0	21.26	AV	119.00	100	Vertical	Pass
2	2413.800	92.61	-14.80	74.0	-18.61	Peak	146.00	200	Vertical	N/A
2**	2413.800	85.23	-14.80	54.0	-31.23	AV	146.00	200	Vertical	N/A
3	2777.300	50.00	-10.20	74.0	24.00	Peak	289.00	100	Vertical	Pass
3**	2777.300	41.11	-10.20	54.0	12.89	AV	289.00	100	Vertical	Pass
4	7683.750	52.31	-0.72	74.0	21.69	Peak	267.00	300	Vertical	Pass
4**	7683.750	43.09	-0.72	54.0	10.91	AV	267.00	300	Vertical	Pass
5	12942.500	45.13	1.28	74.0	28.87	Peak	217.00	400	Vertical	Pass
5**	12942.500	36.40	1.28	54.0	17.60	AV	217.00	400	Vertical	Pass
6	17570.001	47.76	6.24	74.0	26.24	Peak	121.00	200	Vertical	Pass
6**	17570.001	39.72	6.24	54.0	14.28	AV	121.00	200	Vertical	Pass

1 GHz to 18 GHz, ANT H 802.11n20 Middle Channel

No.	Frequency (MHz)	Results (dBuV/m)	Factor (dB)	Limit (dBuV/m)	Margin (dB)	Detector	Table (Degree)	Height (cm)	Antenna	Verdict
1	1579.600	40.17	-19.52	74.0	33.83	Peak	93.00	200	Horizontal	Pass
1**	1579.600	30.28	-19.52	54.0	23.72	AV	93.00	200	Horizontal	Pass
2	2438.800	104.31	-14.30	74.0	-30.31	Peak	165.00	100	Horizontal	N/A
2**	2438.800	96.91	-14.30	54.0	-42.91	AV	165.00	100	Horizontal	N/A
3	2594.700	49.89	-13.45	74.0	24.11	Peak	165.00	200	Horizontal	Pass
3**	2594.700	40.61	-13.45	54.0	13.39	AV	165.00	200	Horizontal	Pass
4	7598.750	53.16	-0.86	74.0	20.84	Peak	36.00	100	Horizontal	Pass
4**	7598.750	42.79	-0.86	54.0	11.21	AV	36.00	100	Horizontal	Pass
5	12335.000	44.96	0.71	74.0	29.04	Peak	230.00	200	Horizontal	Pass
5**	12335.000	37.02	0.71	54.0	16.98	AV	230.00	200	Horizontal	Pass
6	17840.001	48.18	5.44	74.0	25.82	Peak	31.00	400	Horizontal	Pass
6**	17840.001	39.79	5.44	54.0	14.21	AV	31.00	400	Horizontal	Pass

1 GHz to 18 GHz, ANT V 802.11n20 Middle Channel

No.	Frequency (MHz)	Results (dBuV/m)	Factor (dB)	Limit (dBuV/m)	Margin (dB)	Detector	Table (Degree)	Height (cm)	Antenna	Verdict
1	1330.300	41.08	-19.18	74.0	32.92	Peak	318.00	300	Vertical	Pass
1**	1330.300	31.21	-19.18	54.0	22.79	AV	318.00	300	Vertical	Pass
2	2438.900	91.01	-14.28	74.0	-17.01	Peak	283.00	100	Vertical	N/A
2**	2438.900	83.97	-14.28	54.0	-29.97	AV	283.00	100	Vertical	N/A
3	2784.700	49.89	-9.94	74.0	24.11	Peak	92.00	150	Vertical	Pass
3**	2784.700	41.81	-9.94	54.0	12.19	AV	92.00	150	Vertical	Pass
4	7583.000	53.12	0.28	74.0	20.88	Peak	190.00	100	Vertical	Pass
4**	7583.000	44.46	0.28	54.0	9.54	AV	190.00	100	Vertical	Pass
5	12802.500	44.90	1.94	74.0	29.10	Peak	221.00	400	Vertical	Pass
5**	12802.500	37.35	1.94	54.0	16.65	AV	221.00	400	Vertical	Pass
6	17535.001	47.49	6.21	74.0	26.51	Peak	13.00	100	Vertical	Pass
6**	17535.001	40.08	6.21	54.0	13.92	AV	13.00	100	Vertical	Pass

1 GHz to 18 GHz, ANT H 802.11n20 High Channel

No.	Frequency (MHz)	Results (dBuV/m)	Factor (dB)	Limit (dBuV/m)	Margin (dB)	Detector	Table (Degree)	Height (cm)	Antenna	Verdict
1	2381.900	48.85	-14.26	74.0	25.15	Peak	175.00	300	Horizontal	Pass
1**	2381.900	42.61	-14.26	54.0	11.39	AV	175.00	300	Horizontal	Pass
2	2460.000	104.13	-13.64	74.0	-30.13	Peak	166.00	200	Horizontal	N/A
2**	2460.000	96.65	-13.64	54.0	-42.65	AV	166.00	200	Horizontal	N/A
3	2614.700	50.88	-13.36	74.0	23.12	Peak	166.00	100	Horizontal	Pass
3**	2614.700	42.08	-13.36	54.0	11.92	AV	166.00	100	Horizontal	Pass
4	7572.500	52.83	-0.73	74.0	21.17	Peak	68.00	400	Horizontal	Pass
4**	7572.500	43.54	-0.73	54.0	10.46	AV	68.00	400	Horizontal	Pass
5	12752.500	45.25	1.56	74.0	28.75	Peak	343.00	100	Horizontal	Pass
5**	12752.500	37.50	1.56	54.0	16.50	AV	343.00	100	Horizontal	Pass
6	17789.999	47.82	6.22	74.0	26.18	Peak	15.00	300	Horizontal	Pass
6**	17789.999	41.22	6.22	54.0	12.78	AV	15.00	300	Horizontal	Pass

1 GHz to 18 GHz, ANT V 802.11n20 High Channel

No.	Frequency (MHz)	Results (dBuV/m)	Factor (dB)	Limit (dBuV/m)	Margin (dB)	Detector	Table (Degree)	Height (cm)	Antenna	Verdict
1	1531.800	40.02	-19.25	74.0	33.98	Peak	360.00	100	Vertical	Pass
1**	1531.800	30.79	-19.25	54.0	23.21	AV	360.00	100	Vertical	Pass
2	2460.700	92.50	-13.74	74.0	-18.50	Peak	149.00	200	Vertical	N/A
2**	2460.700	84.58	-13.74	54.0	-30.58	AV	149.00	200	Vertical	N/A
3	2784.200	49.74	-10.34	74.0	24.26	Peak	69.00	150	Vertical	Pass
3**	2784.200	40.70	-10.34	54.0	13.30	AV	69.00	150	Vertical	Pass
4	7776.750	53.19	-0.95	74.0	20.81	Peak	359.00	300	Vertical	Pass
4**	7776.750	43.30	-0.95	54.0	10.70	AV	359.00	300	Vertical	Pass
5	12792.500	45.97	1.94	74.0	28.03	Peak	311.00	300	Vertical	Pass
5**	12792.500	37.88	1.94	54.0	16.12	AV	311.00	300	Vertical	Pass
6	17820.000	48.08	5.98	74.0	25.92	Peak	191.00	100	Vertical	Pass
6**	17820.000	41.41	5.98	54.0	12.59	AV	191.00	100	Vertical	Pass

1 GHz to 18 GHz, ANT H 802.11n40 Low Channel

No.	Frequency (MHz)	Results (dBuV/m)	Factor (dB)	Limit (dBuV/m)	Margin (dB)	Detector	Table (Degree)	Height (cm)	Antenna	Verdict
1	1438.300	43.86	-19.67	74.0	30.14	Peak	293.00	200	Horizontal	Pass
1**	1438.300	31.60	-19.67	54.0	22.40	AV	293.00	200	Horizontal	Pass
2	2425.400	100.18	-14.33	74.0	-26.18	Peak	168.00	150	Horizontal	N/A
2**	2425.400	91.85	-14.33	54.0	-37.85	AV	168.00	150	Horizontal	N/A
3	2782.800	50.02	-9.70	74.0	23.98	Peak	176.00	100	Horizontal	Pass
3**	2782.800	41.87	-9.70	54.0	12.13	AV	176.00	100	Horizontal	Pass
4	7390.000	53.14	-1.53	74.0	20.86	Peak	360.00	400	Horizontal	Pass
4**	7390.000	43.52	-1.53	54.0	10.48	AV	360.00	400	Horizontal	Pass
5	12615.000	45.27	1.02	74.0	28.73	Peak	155.00	200	Horizontal	Pass
5**	12615.000	36.49	1.02	54.0	17.51	AV	155.00	200	Horizontal	Pass
6	17777.500	48.20	5.85	74.0	25.80	Peak	134.00	100	Horizontal	Pass
6**	17777.500	39.96	5.85	54.0	14.04	AV	134.00	100	Horizontal	Pass

1 GHz to 18 GHz, ANT V 802.11n40 Low Channel

No.	Frequency (MHz)	Results (dBuV/m)	Factor (dB)	Limit (dBuV/m)	Margin (dB)	Detector	Table (Degree)	Height (cm)	Antenna	Verdict
1	1500.500	40.46	-19.06	74.0	33.54	Peak	76.00	400	Vertical	Pass
1**	1500.500	31.05	-19.06	54.0	22.95	AV	76.00	400	Vertical	Pass
2	2418.500	87.69	-14.42	74.0	-13.69	Peak	156.00	100	Vertical	N/A
2**	2418.500	80.16	-14.42	54.0	-26.16	AV	156.00	100	Vertical	N/A
3	2787.900	50.03	-10.58	74.0	23.97	Peak	102.00	200	Vertical	Pass
3**	2787.900	40.85	-10.58	54.0	13.15	AV	102.00	200	Vertical	Pass
4	7806.000	53.00	-0.12	74.0	21.00	Peak	0.00	100	Vertical	Pass
4**	7806.000	43.22	-0.12	54.0	10.78	AV	0.00	100	Vertical	Pass
5	12762.500	44.94	1.65	74.0	29.06	Peak	39.00	200	Vertical	Pass
5**	12762.500	37.67	1.65	54.0	16.33	AV	39.00	200	Vertical	Pass
6	17797.501	47.65	6.45	74.0	26.35	Peak	323.00	400	Vertical	Pass
6**	17797.501	41.63	6.45	54.0	12.37	AV	323.00	400	Vertical	Pass

1 GHz to 18 GHz, ANT H 802.11n40 Middle Channel

No.	Frequency (MHz)	Results (dBuV/m)	Factor (dB)	Limit (dBuV/m)	Margin (dB)	Detector	Table (Degree)	Height (cm)	Antenna	Verdict
1	1440.500	43.95	-19.51	74.0	30.05	Peak	288.00	400	Horizontal	Pass
1**	1440.500	31.88	-19.51	54.0	22.12	AV	288.00	400	Horizontal	Pass
2	2438.900	101.29	-14.28	74.0	-27.29	Peak	166.00	150	Horizontal	N/A
2**	2438.900	93.55	-14.28	54.0	-39.55	AV	166.00	150	Horizontal	N/A
3	2590.700	51.20	-13.05	74.0	22.80	Peak	157.00	200	Horizontal	Pass
3**	2590.700	41.69	-13.05	54.0	12.31	AV	157.00	200	Horizontal	Pass
4	7351.750	53.38	-1.08	74.0	20.62	Peak	360.00	400	Horizontal	Pass
4**	7351.750	45.41	-1.08	54.0	8.59	AV	360.00	400	Horizontal	Pass
5	12790.000	45.64	1.92	74.0	28.36	Peak	168.00	300	Horizontal	Pass
5**	12790.000	38.13	1.92	54.0	15.87	AV	168.00	300	Horizontal	Pass
6	17789.999	48.27	6.22	74.0	25.73	Peak	62.00	200	Horizontal	Pass
6**	17789.999	41.02	6.22	54.0	12.98	AV	62.00	200	Horizontal	Pass

1 GHz to 18 GHz, ANT V 802.11n40 Middle Channel

No.	Frequency (MHz)	Results (dBuV/m)	Factor (dB)	Limit (dBuV/m)	Margin (dB)	Detector	Table (Degree)	Height (cm)	Antenna	Verdict
1	1493.800	39.82	-19.20	74.0	34.18	Peak	283.00	300	Vertical	Pass
1**	1493.800	30.45	-19.20	54.0	23.55	AV	283.00	300	Vertical	Pass
2	2440.300	86.95	-14.72	74.0	-12.95	Peak	274.00	100	Vertical	N/A
2**	2440.300	78.75	-14.72	54.0	-24.75	AV	274.00	100	Vertical	N/A
3	2779.800	49.70	-10.59	74.0	24.30	Peak	313.00	150	Vertical	Pass
3**	2779.800	40.72	-10.59	54.0	13.28	AV	313.00	150	Vertical	Pass
4	7808.250	52.62	0.11	74.0	21.38	Peak	0.00	300	Vertical	Pass
4**	7808.250	43.43	0.11	54.0	10.57	AV	0.00	300	Vertical	Pass
5	12542.500	45.77	1.44	74.0	28.23	Peak	334.00	200	Vertical	Pass
5**	12542.500	36.84	1.44	54.0	17.16	AV	334.00	200	Vertical	Pass
6	17554.999	48.07	6.44	74.0	25.93	Peak	323.00	300	Vertical	Pass
6**	17554.999	39.63	6.44	54.0	14.37	AV	323.00	300	Vertical	Pass

1 GHz to 18 GHz, ANT H 802.11n40 High Channel

No.	Frequency (MHz)	Results (dBuV/m)	Factor (dB)	Limit (dBuV/m)	Margin (dB)	Detector	Table (Degree)	Height (cm)	Antenna	Verdict
1	1439.900	42.90	-19.53	74.0	31.10	Peak	303.00	300	Horizontal	Pass
1**	1439.900	32.52	-19.53	54.0	21.48	AV	303.00	300	Horizontal	Pass
2	2461.200	100.23	-13.72	74.0	-26.23	Peak	172.00	100	Horizontal	N/A
2**	2461.200	92.90	-13.72	54.0	-38.90	AV	172.00	100	Horizontal	N/A
3	2615.000	50.92	-13.40	74.0	23.08	Peak	172.00	200	Horizontal	Pass
3**	2615.000	41.05	-13.40	54.0	12.95	AV	172.00	200	Horizontal	Pass
4	7582.750	53.17	0.29	74.0	20.83	Peak	0.00	300	Horizontal	Pass
4**	7582.750	44.26	0.29	54.0	9.74	AV	0.00	300	Horizontal	Pass
5	12785.000	45.60	1.87	74.0	28.40	Peak	31.00	400	Horizontal	Pass
5**	12785.000	37.62	1.87	54.0	16.38	AV	31.00	400	Horizontal	Pass
6	17529.999	47.59	6.12	74.0	26.41	Peak	242.00	200	Horizontal	Pass
6**	17529.999	40.10	6.12	54.0	13.90	AV	242.00	200	Horizontal	Pass

1 GHz to 18 GHz, ANT V 802.11n40 High Channel

No.	Frequency (MHz)	Results (dBuV/m)	Factor (dB)	Limit (dBuV/m)	Margin (dB)	Detector	Table (Degree)	Height (cm)	Antenna	Verdict
1	1410.100	41.44	-19.19	74.0	32.56	Peak	92.00	100	Vertical	Pass
1**	1410.100	31.15	-19.19	54.0	22.85	AV	92.00	100	Vertical	Pass
2	2459.200	89.71	-13.52	74.0	-15.71	Peak	152.00	200	Vertical	N/A
2**	2459.200	82.02	-13.52	54.0	-28.02	AV	152.00	200	Vertical	N/A
3	2783.000	50.61	-9.46	74.0	23.39	Peak	65.00	150	Vertical	Pass
3**	2783.000	42.19	-9.46	54.0	11.81	AV	65.00	150	Vertical	Pass
4	7334.500	53.18	-1.22	74.0	20.82	Peak	352.00	400	Vertical	Pass
4**	7334.500	44.39	-1.22	54.0	9.61	AV	352.00	400	Vertical	Pass
5	12860.000	45.89	0.43	74.0	28.11	Peak	45.00	200	Vertical	Pass
5**	12860.000	37.40	0.43	54.0	16.60	AV	45.00	200	Vertical	Pass
6	17767.500	48.44	5.55	74.0	25.56	Peak	159.00	300	Vertical	Pass
6**	17767.500	39.33	5.55	54.0	14.67	AV	159.00	300	Vertical	Pass

Aux. Antenna**1 GHz to 18 GHz, ANT H 802.11b Low Channel**

No.	Frequency (MHz)	Results (dBuV/m)	Factor (dB)	Limit (dBuV/m)	Margin (dB)	Detector	Table (Degree)	Height (cm)	Antenna	Verdict
1	2252.300	52.63	-13.79	74.0	21.37	Peak	52.00	100	Horizontal	Pass
1**	2252.300	47.63	-13.79	54.0	6.37	AV	52.00	100	Horizontal	Pass
2	2412.000	100.69	-14.99	74.0	-26.69	Peak	34.00	150	Horizontal	N/A
2**	2412.000	96.04	-14.99	54.0	-42.04	AV	34.00	150	Horizontal	N/A
3	2569.300	50.95	-12.73	74.0	23.05	Peak	43.00	100	Horizontal	Pass
3**	2569.300	43.13	-12.73	54.0	10.87	AV	43.00	100	Horizontal	Pass
4	7781.750	53.00	-0.99	74.0	21.00	Peak	231.00	100	Horizontal	Pass
4**	7781.750	43.68	-0.99	54.0	10.32	AV	231.00	100	Horizontal	Pass
5	12682.500	45.31	0.59	74.0	28.69	Peak	183.00	100	Horizontal	Pass
5**	12682.500	36.54	0.59	54.0	17.46	AV	183.00	100	Horizontal	Pass
6	17567.500	49.71	6.27	74.0	24.29	Peak	42.00	300	Horizontal	Pass
6**	17567.500	39.47	6.27	54.0	14.53	AV	42.00	300	Horizontal	Pass

1 GHz to 18 GHz, ANT V 802.11b Low Channel

No.	Frequency (MHz)	Results (dBuV/m)	Factor (dB)	Limit (dBuV/m)	Margin (dB)	Detector	Table (Degree)	Height (cm)	Antenna	Verdict
1	1510.400	42.21	-18.84	74.0	31.79	Peak	310.00	200	Vertical	Pass
1**	1510.400	31.65	-18.84	54.0	22.35	AV	310.00	200	Vertical	Pass
2	2412.000	92.19	-14.99	74.0	-18.19	Peak	130.00	100	Vertical	N/A
2**	2412.000	86.11	-14.99	54.0	-32.11	AV	130.00	100	Vertical	N/A
3	2776.700	50.01	-10.47	74.0	23.99	Peak	139.00	100	Vertical	Pass
3**	2776.700	41.59	-10.47	54.0	12.41	AV	139.00	100	Vertical	Pass
4	7580.250	52.83	0.18	74.0	21.17	Peak	359.00	200	Vertical	Pass
4**	7580.250	43.85	0.18	54.0	10.15	AV	359.00	200	Vertical	Pass
5	12765.000	45.84	1.68	74.0	28.16	Peak	80.00	200	Vertical	Pass
5**	12765.000	37.31	1.68	54.0	16.69	AV	80.00	200	Vertical	Pass
6	17822.501	49.03	5.91	74.0	24.97	Peak	164.00	300	Vertical	Pass
6**	17822.501	40.25	5.91	54.0	13.75	AV	164.00	300	Vertical	Pass

1 GHz to 18 GHz, ANT H 802.11b Middle Channel

No.	Frequency (MHz)	Results (dBuV/m)	Factor (dB)	Limit (dBuV/m)	Margin (dB)	Detector	Table (Degree)	Height (cm)	Antenna	Verdict
1	2275.900	49.85	-14.65	74.0	24.15	Peak	338.00	300	Horizontal	Pass
1**	2275.900	42.58	-14.65	54.0	11.42	AV	338.00	300	Horizontal	Pass
2	2437.100	102.11	-14.58	74.0	-28.11	Peak	165.00	100	Horizontal	N/A
2**	2437.100	96.69	-14.58	54.0	-42.69	AV	165.00	100	Horizontal	N/A
3	2598.200	50.12	-13.58	74.0	23.88	Peak	41.00	200	Horizontal	Pass
3**	2598.200	43.34	-13.58	54.0	10.66	AV	41.00	200	Horizontal	Pass
4	7751.250	52.65	-0.22	74.0	21.35	Peak	69.00	200	Horizontal	Pass
4**	7751.250	44.42	-0.22	54.0	9.58	AV	69.00	200	Horizontal	Pass
5	12767.500	45.71	1.70	74.0	28.29	Peak	360.00	300	Horizontal	Pass
5**	12767.500	39.49	1.70	54.0	14.51	AV	360.00	300	Horizontal	Pass
6	17792.500	48.89	6.30	74.0	25.11	Peak	331.00	100	Horizontal	Pass
6**	17792.500	40.74	6.30	54.0	13.26	AV	331.00	100	Horizontal	Pass

1 GHz to 18 GHz, ANT V 802.11b Middle Channel

No.	Frequency (MHz)	Results (dBuV/m)	Factor (dB)	Limit (dBuV/m)	Margin (dB)	Detector	Table (Degree)	Height (cm)	Antenna	Verdict
1	1332.000	40.36	-19.92	74.0	33.64	Peak	287.00	100	Vertical	Pass
1**	1332.000	30.24	-19.92	54.0	23.76	AV	287.00	100	Vertical	Pass
2	2437.000	93.81	-14.63	74.0	-19.81	Peak	75.00	150	Vertical	N/A
2**	2437.000	89.21	-14.63	54.0	-35.21	AV	75.00	150	Vertical	N/A
3	2871.500	49.93	-11.42	74.0	24.07	Peak	95.00	150	Vertical	Pass
3**	2871.500	39.68	-11.42	54.0	14.32	AV	95.00	150	Vertical	Pass
4	7571.250	53.19	-0.79	74.0	20.81	Peak	0.00	200	Vertical	Pass
4**	7571.250	42.92	-0.79	54.0	11.08	AV	0.00	200	Vertical	Pass
5	12817.500	45.89	1.47	74.0	28.11	Peak	52.00	300	Vertical	Pass
5**	12817.500	37.96	1.47	54.0	16.04	AV	52.00	300	Vertical	Pass
6	17817.500	47.79	6.05	74.0	26.21	Peak	287.00	200	Vertical	Pass
6**	17817.500	41.46	6.05	54.0	12.54	AV	287.00	200	Vertical	Pass

1 GHz to 18 GHz, ANT H 802.11b High Channel

No.	Frequency (MHz)	Results (dBuV/m)	Factor (dB)	Limit (dBuV/m)	Margin (dB)	Detector	Table (Degree)	Height (cm)	Antenna	Verdict
1	2300.200	50.81	-15.28	74.0	23.19	Peak	344.00	100	Horizontal	Pass
1**	2300.200	42.98	-15.28	54.0	11.02	AV	344.00	100	Horizontal	Pass
2	2462.100	102.50	-14.07	74.0	-28.50	Peak	169.00	200	Horizontal	N/A
2**	2462.100	97.44	-14.07	54.0	-43.44	AV	169.00	200	Horizontal	N/A
3	2783.100	50.96	-9.34	74.0	23.04	Peak	22.00	200	Horizontal	Pass
3**	2783.100	41.99	-9.34	54.0	12.01	AV	22.00	200	Horizontal	Pass
4	7801.000	53.47	0.40	74.0	20.53	Peak	0.00	400	Horizontal	Pass
4**	7801.000	44.42	0.40	54.0	9.58	AV	0.00	400	Horizontal	Pass
5	12760.001	45.60	1.63	74.0	28.40	Peak	359.00	100	Horizontal	Pass
5**	12760.001	37.57	1.63	54.0	16.43	AV	359.00	100	Horizontal	Pass
6	17540.000	47.87	6.31	74.0	26.13	Peak	260.00	300	Horizontal	Pass
6**	17540.000	40.53	6.31	54.0	13.47	AV	260.00	300	Horizontal	Pass

1 GHz to 18 GHz, ANT V 802.11b High Channel

No.	Frequency (MHz)	Results (dBuV/m)	Factor (dB)	Limit (dBuV/m)	Margin (dB)	Detector	Table (Degree)	Height (cm)	Antenna	Verdict
1	1327.500	42.18	-19.28	74.0	31.82	Peak	119.00	400	Vertical	Pass
1**	1327.500	30.33	-19.28	54.0	23.67	AV	119.00	400	Vertical	Pass
2	2462.000	93.33	-14.13	74.0	-19.33	Peak	282.00	150	Vertical	N/A
2**	2462.000	88.22	-14.13	54.0	-34.22	AV	282.00	150	Vertical	N/A
3	2782.500	50.13	-9.89	74.0	23.87	Peak	179.00	200	Vertical	Pass
3**	2782.500	40.99	-9.89	54.0	13.01	AV	179.00	200	Vertical	Pass
4	7691.500	53.53	-0.66	74.0	20.47	Peak	354.00	200	Vertical	Pass
4**	7691.500	43.96	-0.66	54.0	10.04	AV	354.00	200	Vertical	Pass
5	12757.500	45.10	1.61	74.0	28.90	Peak	314.00	300	Vertical	Pass
5**	12757.500	37.96	1.61	54.0	16.04	AV	314.00	300	Vertical	Pass
6	17812.500	49.12	6.19	74.0	24.88	Peak	153.00	100	Vertical	Pass
6**	17812.500	40.39	6.19	54.0	13.61	AV	153.00	100	Vertical	Pass

1 GHz to 18 GHz, ANT H 802.11g Low Channel

No.	Frequency (MHz)	Results (dBuV/m)	Factor (dB)	Limit (dBuV/m)	Margin (dB)	Detector	Table (Degree)	Height (cm)	Antenna	Verdict
1	2252.500	48.98	-14.12	74.0	25.02	Peak	334.00	100	Horizontal	Pass
1**	2252.500	41.88	-14.12	54.0	12.12	AV	334.00	100	Horizontal	Pass
2	2411.200	101.10	-14.74	74.0	-27.10	Peak	182.00	200	Horizontal	N/A
2**	2411.200	94.24	-14.74	54.0	-40.24	AV	182.00	200	Horizontal	N/A
3	2568.700	50.72	-12.83	74.0	23.28	Peak	360.00	100	Horizontal	Pass
3**	2568.700	41.78	-12.83	54.0	12.22	AV	360.00	100	Horizontal	Pass
4	7471.250	52.31	-1.11	74.0	21.69	Peak	140.00	200	Horizontal	Pass
4**	7471.250	42.87	-1.11	54.0	11.13	AV	140.00	200	Horizontal	Pass
5	12770.000	45.40	1.73	74.0	28.60	Peak	177.00	100	Horizontal	Pass
5**	12770.000	37.96	1.73	54.0	16.04	AV	177.00	100	Horizontal	Pass
6	17795.000	49.16	6.37	74.0	24.84	Peak	296.00	400	Horizontal	Pass
6**	17795.000	41.20	6.37	54.0	12.80	AV	296.00	400	Horizontal	Pass

1 GHz to 18 GHz, ANT V 802.11g Low Channel

No.	Frequency (MHz)	Results (dBuV/m)	Factor (dB)	Limit (dBuV/m)	Margin (dB)	Detector	Table (Degree)	Height (cm)	Antenna	Verdict
1	1531.500	40.67	-19.43	74.0	33.33	Peak	304.00	400	Vertical	Pass
1**	1531.500	31.87	-19.43	54.0	22.13	AV	304.00	400	Vertical	Pass
2	2413.500	92.33	-14.76	74.0	-18.33	Peak	130.00	150	Vertical	N/A
2**	2413.500	85.03	-14.76	54.0	-31.03	AV	130.00	150	Vertical	N/A
3	2782.400	50.89	-9.91	74.0	23.11	Peak	182.00	100	Vertical	Pass
3**	2782.400	41.16	-9.91	54.0	12.84	AV	182.00	100	Vertical	Pass
4	7586.000	52.73	-0.09	74.0	21.27	Peak	252.00	300	Vertical	Pass
4**	7586.000	43.80	-0.09	54.0	10.20	AV	252.00	300	Vertical	Pass
5	12790.000	45.61	1.92	74.0	28.39	Peak	265.00	100	Vertical	Pass
5**	12790.000	39.06	1.92	54.0	14.94	AV	265.00	100	Vertical	Pass
6	17792.500	48.29	6.30	74.0	25.71	Peak	156.00	200	Vertical	Pass
6**	17792.500	41.97	6.30	54.0	12.03	AV	156.00	200	Vertical	Pass

1 GHz to 18 GHz, ANT H 802.11g Middle Channel

No.	Frequency (MHz)	Results (dBuV/m)	Factor (dB)	Limit (dBuV/m)	Margin (dB)	Detector	Table (Degree)	Height (cm)	Antenna	Verdict
1	2277.800	48.88	-14.75	74.0	25.12	Peak	48.00	200	Horizontal	Pass
1**	2277.800	41.73	-14.75	54.0	12.27	AV	48.00	200	Horizontal	Pass
2	2436.300	102.57	-14.76	74.0	-28.57	Peak	166.00	150	Horizontal	N/A
2**	2436.300	94.60	-14.76	54.0	-40.60	AV	166.00	150	Horizontal	N/A
3	2782.100	50.59	-10.15	74.0	23.41	Peak	192.00	200	Horizontal	Pass
3**	2782.100	41.88	-10.15	54.0	12.12	AV	192.00	200	Horizontal	Pass
4	7760.750	52.68	-0.24	74.0	21.32	Peak	179.00	200	Horizontal	Pass
4**	7760.750	43.51	-0.24	54.0	10.49	AV	179.00	200	Horizontal	Pass
5	12760.001	45.65	1.63	74.0	28.35	Peak	107.00	300	Horizontal	Pass
5**	12760.001	37.98	1.63	54.0	16.02	AV	107.00	300	Horizontal	Pass
6	17824.999	48.75	5.85	74.0	25.25	Peak	97.00	200	Horizontal	Pass
6**	17824.999	40.08	5.85	54.0	13.92	AV	97.00	200	Horizontal	Pass

1 GHz to 18 GHz, ANT V 802.11g Middle Channel

No.	Frequency (MHz)	Results (dBuV/m)	Factor (dB)	Limit (dBuV/m)	Margin (dB)	Detector	Table (Degree)	Height (cm)	Antenna	Verdict
1	1511.200	40.78	-18.98	74.0	33.22	Peak	246.00	300	Vertical	Pass
1**	1511.200	31.10	-18.98	54.0	22.90	AV	246.00	300	Vertical	Pass
2	2440.900	93.83	-14.23	74.0	-19.83	Peak	72.00	100	Vertical	N/A
2**	2440.900	87.19	-14.23	54.0	-33.19	AV	72.00	100	Vertical	N/A
3	2783.100	51.21	-9.34	74.0	22.79	Peak	72.00	150	Vertical	Pass
3**	2783.100	42.45	-9.34	54.0	11.55	AV	72.00	150	Vertical	Pass
4	7756.250	52.92	0.06	74.0	21.08	Peak	153.00	200	Vertical	Pass
4**	7756.250	43.76	0.06	54.0	10.24	AV	153.00	200	Vertical	Pass
5	12792.500	45.60	1.94	74.0	28.40	Peak	228.00	300	Vertical	Pass
5**	12792.500	38.34	1.94	54.0	15.66	AV	228.00	300	Vertical	Pass
6	17814.999	47.92	6.12	74.0	26.08	Peak	259.00	300	Vertical	Pass
6**	17814.999	40.35	6.12	54.0	13.65	AV	259.00	300	Vertical	Pass

1 GHz to 18 GHz, ANT H 802.11g High Channel

No.	Frequency (MHz)	Results (dBuV/m)	Factor (dB)	Limit (dBuV/m)	Margin (dB)	Detector	Table (Degree)	Height (cm)	Antenna	Verdict
1	2300.100	49.86	-15.35	74.0	24.14	Peak	340.00	100	Horizontal	Pass
1**	2300.100	41.03	-15.35	54.0	12.97	AV	340.00	100	Horizontal	Pass
2	2459.700	104.87	-13.35	74.0	-30.87	Peak	158.00	150	Horizontal	N/A
2**	2459.700	98.61	-13.35	54.0	-44.61	AV	158.00	150	Horizontal	N/A
3	2776.600	49.93	-10.52	74.0	24.07	Peak	98.00	100	Horizontal	Pass
3**	2776.600	41.36	-10.52	54.0	12.64	AV	98.00	100	Horizontal	Pass
4	7756.500	52.43	-0.06	74.0	21.57	Peak	345.00	300	Horizontal	Pass
4**	7756.500	44.26	-0.06	54.0	9.74	AV	345.00	300	Horizontal	Pass
5	12797.500	45.53	1.99	74.0	28.47	Peak	202.00	100	Horizontal	Pass
5**	12797.500	38.33	1.99	54.0	15.67	AV	202.00	100	Horizontal	Pass
6	17805.001	48.55	6.39	74.0	25.45	Peak	296.00	200	Horizontal	Pass
6**	17805.001	40.85	6.39	54.0	13.15	AV	296.00	200	Horizontal	Pass

1 GHz to 18 GHz, ANT V 802.11n20 High Channel

No.	Frequency (MHz)	Results (dBuV/m)	Factor (dB)	Limit (dBuV/m)	Margin (dB)	Detector	Table (Degree)	Height (cm)	Antenna	Verdict
1	1319.000	41.19	-18.91	74.0	32.81	Peak	136.00	300	Vertical	Pass
1**	1319.000	31.00	-18.91	54.0	23.00	AV	136.00	300	Vertical	Pass
2	2459.800	94.73	-13.45	74.0	-20.73	Peak	136.00	100	Vertical	N/A
2**	2459.800	87.18	-13.45	54.0	-33.18	AV	136.00	100	Vertical	N/A
3	2783.400	50.10	-9.95	74.0	23.90	Peak	240.00	150	Vertical	Pass
3**	2783.400	41.29	-9.95	54.0	12.71	AV	240.00	150	Vertical	Pass
4	7804.250	52.99	0.08	74.0	21.01	Peak	50.00	200	Vertical	Pass
4**	7804.250	43.76	0.08	54.0	10.24	AV	50.00	200	Vertical	Pass
5	12790.000	45.00	1.92	74.0	29.00	Peak	95.00	100	Vertical	Pass
5**	12790.000	37.98	1.92	54.0	16.02	AV	95.00	100	Vertical	Pass
6	17807.499	48.25	6.32	74.0	25.75	Peak	155.00	300	Vertical	Pass
6**	17807.499	40.69	6.32	54.0	13.31	AV	155.00	300	Vertical	Pass

1 GHz to 18 GHz, ANT H 802.11n20 Low Channel

No.	Frequency (MHz)	Results (dBuV/m)	Factor (dB)	Limit (dBuV/m)	Margin (dB)	Detector	Table (Degree)	Height (cm)	Antenna	Verdict
1	2252.300	49.81	-13.79	74.0	24.19	Peak	341.00	200	Horizontal	Pass
1**	2252.300	42.59	-13.79	54.0	11.41	AV	341.00	200	Horizontal	Pass
2	2410.800	103.18	-15.16	74.0	-29.18	Peak	192.00	100	Horizontal	N/A
2**	2410.800	95.85	-15.16	54.0	-41.85	AV	192.00	100	Horizontal	N/A
3	2564.700	50.67	-12.46	74.0	23.33	Peak	315.00	200	Horizontal	Pass
3**	2564.700	41.52	-12.46	54.0	12.48	AV	315.00	200	Horizontal	Pass
4	7658.500	52.93	-1.43	74.0	21.07	Peak	122.00	400	Horizontal	Pass
4**	7658.500	43.02	-1.43	54.0	10.98	AV	122.00	400	Horizontal	Pass
5	12945.000	45.43	1.34	74.0	28.57	Peak	236.00	300	Horizontal	Pass
5**	12945.000	36.89	1.34	54.0	17.11	AV	236.00	300	Horizontal	Pass
6	17792.500	48.10	6.30	74.0	25.90	Peak	241.00	100	Horizontal	Pass
6**	17792.500	41.04	6.30	54.0	12.96	AV	241.00	100	Horizontal	Pass

1 GHz to 18 GHz, ANT V 802.11n20 Low Channel

No.	Frequency (MHz)	Results (dBuV/m)	Factor (dB)	Limit (dBuV/m)	Margin (dB)	Detector	Table (Degree)	Height (cm)	Antenna	Verdict
1	1578.700	40.41	-19.04	74.0	33.59	Peak	233.00	300	Vertical	Pass
1**	1578.700	31.15	-19.04	54.0	22.85	AV	233.00	300	Vertical	Pass
2	2411.900	92.47	-15.00	74.0	-18.47	Peak	129.00	200	Vertical	N/A
2**	2411.900	85.12	-15.00	54.0	-31.12	AV	129.00	200	Vertical	N/A
3	2785.200	50.06	-10.04	74.0	23.94	Peak	7.00	100	Vertical	Pass
3**	2785.200	41.55	-10.04	54.0	12.45	AV	7.00	100	Vertical	Pass
4	7367.500	52.56	-0.63	74.0	21.44	Peak	360.00	200	Vertical	Pass
4**	7367.500	43.43	-0.63	54.0	10.57	AV	360.00	200	Vertical	Pass
5	12787.500	45.42	1.89	74.0	28.58	Peak	196.00	100	Vertical	Pass
5**	12787.500	37.99	1.89	54.0	16.01	AV	196.00	100	Vertical	Pass
6	17797.501	48.42	6.45	74.0	25.58	Peak	268.00	300	Vertical	Pass
6**	17797.501	40.71	6.45	54.0	13.29	AV	268.00	300	Vertical	Pass

1 GHz to 18 GHz, ANT H 802.11n20 Middle Channel

No.	Frequency (MHz)	Results (dBuV/m)	Factor (dB)	Limit (dBuV/m)	Margin (dB)	Detector	Table (Degree)	Height (cm)	Antenna	Verdict
1	2275.400	49.22	-15.20	74.0	24.78	Peak	47.00	400	Horizontal	Pass
1**	2275.400	40.10	-15.20	54.0	13.90	AV	47.00	400	Horizontal	Pass
2	2438.200	104.00	-14.69	74.0	-30.00	Peak	160.00	200	Horizontal	N/A
2**	2438.200	97.12	-14.69	54.0	-43.12	AV	160.00	200	Horizontal	N/A
3	2595.200	49.68	-13.19	74.0	24.32	Peak	349.00	200	Horizontal	Pass
3**	2595.200	40.66	-13.19	54.0	13.34	AV	349.00	200	Horizontal	Pass
4	7767.250	52.59	-0.44	74.0	21.41	Peak	34.00	300	Horizontal	Pass
4**	7767.250	43.38	-0.44	54.0	10.62	AV	34.00	300	Horizontal	Pass
5	12765.000	45.95	1.68	74.0	28.05	Peak	3.00	100	Horizontal	Pass
5**	12765.000	38.09	1.68	54.0	15.91	AV	3.00	100	Horizontal	Pass
6	17787.501	48.36	6.15	74.0	25.64	Peak	225.00	200	Horizontal	Pass
6**	17787.501	40.65	6.15	54.0	13.35	AV	225.00	200	Horizontal	Pass

1 GHz to 18 GHz, ANT V 802.11n20 Middle Channel

No.	Frequency (MHz)	Results (dBuV/m)	Factor (dB)	Limit (dBuV/m)	Margin (dB)	Detector	Table (Degree)	Height (cm)	Antenna	Verdict
1	1330.200	42.90	-19.13	74.0	31.10	Peak	112.00	400	Vertical	Pass
1**	1330.200	30.99	-19.13	54.0	23.01	AV	112.00	400	Vertical	Pass
2	2437.200	94.90	-14.60	74.0	-20.90	Peak	78.00	100	Vertical	N/A
2**	2437.200	87.00	-14.60	54.0	-33.00	AV	78.00	100	Vertical	N/A
3	2786.300	50.13	-9.93	74.0	23.87	Peak	26.00	200	Vertical	Pass
3**	2786.300	41.38	-9.93	54.0	12.62	AV	26.00	200	Vertical	Pass
4	7498.500	52.97	0.04	74.0	21.03	Peak	0.00	100	Vertical	Pass
4**	7498.500	42.81	0.04	54.0	11.19	AV	0.00	100	Vertical	Pass
5	12760.001	46.43	1.63	74.0	27.57	Peak	13.00	200	Vertical	Pass
5**	12760.001	38.53	1.63	54.0	15.47	AV	13.00	200	Vertical	Pass
6	17802.500	48.07	6.46	74.0	25.93	Peak	351.00	300	Vertical	Pass
6**	17802.500	40.99	6.46	54.0	13.01	AV	351.00	300	Vertical	Pass

1 GHz to 18 GHz, ANT H 802.11n20 High Channel

No.	Frequency (MHz)	Results (dBuV/m)	Factor (dB)	Limit (dBuV/m)	Margin (dB)	Detector	Table (Degree)	Height (cm)	Antenna	Verdict
1	2305.900	50.32	-14.68	74.0	23.68	Peak	345.00	200	Horizontal	Pass
1**	2305.900	40.98	-14.68	54.0	13.02	AV	345.00	200	Horizontal	Pass
2	2462.200	105.46	-14.02	74.0	-31.46	Peak	171.00	100	Horizontal	N/A
2**	2462.200	97.94	-14.02	54.0	-43.94	AV	171.00	100	Horizontal	N/A
3	2783.100	50.40	-9.34	74.0	23.60	Peak	301.00	200	Horizontal	Pass
3**	2783.100	41.85	-9.34	54.0	12.15	AV	301.00	200	Horizontal	Pass
4	7691.500	53.02	-0.66	74.0	20.98	Peak	163.00	300	Horizontal	Pass
4**	7691.500	43.12	-0.66	54.0	10.88	AV	163.00	300	Horizontal	Pass
5	12785.000	45.06	1.87	74.0	28.94	Peak	210.00	400	Horizontal	Pass
5**	12785.000	38.70	1.87	54.0	15.30	AV	210.00	400	Horizontal	Pass
6	17789.999	48.17	6.22	74.0	25.83	Peak	177.00	400	Horizontal	Pass
6**	17789.999	40.51	6.22	54.0	13.49	AV	177.00	400	Horizontal	Pass

1 GHz to 18 GHz, ANT V 802.11n40 High Channel

No.	Frequency (MHz)	Results (dBuV/m)	Factor (dB)	Limit (dBuV/m)	Margin (dB)	Detector	Table (Degree)	Height (cm)	Antenna	Verdict
1	1423.000	40.05	-19.45	74.0	33.95	Peak	0.00	300	Vertical	Pass
1**	1423.000	31.40	-19.45	54.0	22.60	AV	0.00	300	Vertical	Pass
2	2459.600	94.60	-13.37	74.0	-20.60	Peak	274.00	200	Vertical	N/A
2**	2459.600	87.08	-13.37	54.0	-33.08	AV	274.00	200	Vertical	N/A
3	2782.200	49.54	-10.01	74.0	24.46	Peak	117.00	200	Vertical	Pass
3**	2782.200	41.87	-10.01	54.0	12.13	AV	117.00	200	Vertical	Pass
4	7649.250	52.81	-1.06	74.0	21.19	Peak	85.00	400	Vertical	Pass
4**	7649.250	43.54	-1.06	54.0	10.46	AV	85.00	400	Vertical	Pass
5	12582.500	45.55	1.31	74.0	28.45	Peak	267.00	100	Vertical	Pass
5**	12582.500	37.97	1.31	54.0	16.03	AV	267.00	100	Vertical	Pass
6	17577.501	48.75	6.14	74.0	25.25	Peak	12.00	300	Vertical	Pass
6**	17577.501	40.11	6.14	54.0	13.89	AV	12.00	300	Vertical	Pass

1 GHz to 18 GHz, ANT H 802.11n40 Low Channel

No.	Frequency (MHz)	Results (dBuV/m)	Factor (dB)	Limit (dBuV/m)	Margin (dB)	Detector	Table (Degree)	Height (cm)	Antenna	Verdict
1	1437.700	41.08	-19.78	74.0	32.92	Peak	156.00	100	Horizontal	Pass
1**	1437.700	30.24	-19.78	54.0	23.76	AV	156.00	100	Horizontal	Pass
2	2423.900	101.30	-13.73	74.0	-27.30	Peak	164.00	150	Horizontal	N/A
2**	2423.900	93.85	-13.73	54.0	-39.85	AV	164.00	150	Horizontal	N/A
3	2782.200	49.94	-10.01	74.0	24.06	Peak	242.00	100	Horizontal	Pass
3**	2782.200	40.97	-10.01	54.0	13.03	AV	242.00	100	Horizontal	Pass
4	7757.250	52.64	-0.25	74.0	21.36	Peak	330.00	100	Horizontal	Pass
4**	7757.250	44.13	-0.25	54.0	9.87	AV	330.00	100	Horizontal	Pass
5	12770.000	46.34	1.73	74.0	27.66	Peak	199.00	400	Horizontal	Pass
5**	12770.000	38.60	1.73	54.0	15.40	AV	199.00	400	Horizontal	Pass
6	17554.999	47.73	6.44	74.0	26.27	Peak	1.00	200	Horizontal	Pass
6**	17554.999	39.97	6.44	54.0	14.03	AV	1.00	200	Horizontal	Pass

1 GHz to 18 GHz, ANT V 802.11n40 Low Channel

No.	Frequency (MHz)	Results (dBuV/m)	Factor (dB)	Limit (dBuV/m)	Margin (dB)	Detector	Table (Degree)	Height (cm)	Antenna	Verdict
1	1326.800	40.06	-19.19	74.0	33.94	Peak	112.00	400	Vertical	Pass
1**	1326.800	30.93	-19.19	54.0	23.07	AV	112.00	400	Vertical	Pass
2	2426.800	91.05	-14.25	74.0	-17.05	Peak	142.00	150	Vertical	N/A
2**	2426.800	83.42	-14.25	54.0	-29.42	AV	142.00	150	Vertical	N/A
3	2783.000	50.62	-9.46	74.0	23.38	Peak	247.00	200	Vertical	Pass
3**	2783.000	42.67	-9.46	54.0	11.33	AV	247.00	200	Vertical	Pass
4	7390.000	53.59	-1.53	74.0	20.41	Peak	0.00	300	Vertical	Pass
4**	7390.000	43.16	-1.53	54.0	10.84	AV	0.00	300	Vertical	Pass
5	12785.000	45.91	1.87	74.0	28.09	Peak	278.00	400	Vertical	Pass
5**	12785.000	37.69	1.87	54.0	16.31	AV	278.00	400	Vertical	Pass
6	17795.000	47.61	6.37	74.0	26.39	Peak	350.00	100	Vertical	Pass
6**	17795.000	41.63	6.37	54.0	12.37	AV	350.00	100	Vertical	Pass

1 GHz to 18 GHz, ANT H 802.11n40 Middle Channel

No.	Frequency (MHz)	Results (dBuV/m)	Factor (dB)	Limit (dBuV/m)	Margin (dB)	Detector	Table (Degree)	Height (cm)	Antenna	Verdict
1	1350.000	40.50	-19.42	74.0	33.50	Peak	102.00	400	Horizontal	Pass
1**	1350.000	30.24	-19.42	54.0	23.76	AV	102.00	400	Horizontal	Pass
2	2442.400	102.42	-14.45	74.0	-28.42	Peak	173.00	150	Horizontal	N/A
2**	2442.400	93.79	-14.45	54.0	-39.79	AV	173.00	150	Horizontal	N/A
3	2785.500	49.51	-10.08	74.0	24.49	Peak	360.00	200	Horizontal	Pass
3**	2785.500	40.89	-10.08	54.0	13.11	AV	360.00	200	Horizontal	Pass
4	7931.250	52.58	-0.50	74.0	21.42	Peak	360.00	400	Horizontal	Pass
4**	7931.250	42.36	-0.50	54.0	11.64	AV	360.00	400	Horizontal	Pass
5	12460.000	45.70	0.81	74.0	28.30	Peak	325.00	300	Horizontal	Pass
5**	12460.000	36.87	0.81	54.0	17.13	AV	325.00	300	Horizontal	Pass
6	17827.500	48.59	5.78	74.0	25.41	Peak	245.00	200	Horizontal	Pass
6**	17827.500	41.06	5.78	54.0	12.94	AV	245.00	200	Horizontal	Pass
1	1350.000	40.50	-19.42	74.0	33.50	Peak	102.00	400	Horizontal	Pass

1 GHz to 18 GHz, ANT V 802.11n40 Middle Channel

No.	Frequency (MHz)	Results (dBuV/m)	Factor (dB)	Limit (dBuV/m)	Margin (dB)	Detector	Table (Degree)	Height (cm)	Antenna	Verdict
1	1532.800	40.40	-19.32	74.0	33.60	Peak	241.00	200	Vertical	Pass
1**	1532.800	30.74	-19.32	54.0	23.26	AV	241.00	200	Vertical	Pass
2	2438.900	91.32	-14.28	74.0	-17.32	Peak	74.00	150	Vertical	N/A
2**	2438.900	84.04	-14.28	54.0	-30.04	AV	74.00	150	Vertical	N/A
3	2786.400	49.83	-9.88	74.0	24.17	Peak	223.00	100	Vertical	Pass
3**	2786.400	41.51	-9.88	54.0	12.49	AV	223.00	100	Vertical	Pass
4	7783.250	52.84	-0.94	74.0	21.16	Peak	266.00	200	Vertical	Pass
4**	7783.250	43.44	-0.94	54.0	10.56	AV	266.00	200	Vertical	Pass
5	12460.000	45.21	0.81	74.0	28.79	Peak	281.00	100	Vertical	Pass
5**	12460.000	37.12	0.81	54.0	16.88	AV	281.00	100	Vertical	Pass
6	17575.000	47.78	6.18	74.0	26.22	Peak	359.00	200	Vertical	Pass
6**	17575.000	40.64	6.18	54.0	13.36	AV	359.00	200	Vertical	Pass

1 GHz to 18 GHz, ANT H 802.11n40 High Channel

No.	Frequency (MHz)	Results (dBuV/m)	Factor (dB)	Limit (dBuV/m)	Margin (dB)	Detector	Table (Degree)	Height (cm)	Antenna	Verdict
1	2292.000	48.74	-15.29	74.0	25.26	Peak	333.00	400	Horizontal	Pass
1**	2292.000	42.43	-15.29	54.0	11.57	AV	333.00	400	Horizontal	Pass
2	2457.200	102.47	-13.22	74.0	-28.47	Peak	166.00	200	Horizontal	N/A
2**	2457.200	94.90	-13.22	54.0	-40.90	AV	166.00	200	Horizontal	N/A
3	2785.100	49.73	-9.97	74.0	24.27	Peak	36.00	300	Horizontal	Pass
3**	2785.100	41.15	-9.97	54.0	12.85	AV	36.00	300	Horizontal	Pass
4	7723.000	52.79	-1.35	74.0	21.21	Peak	329.00	100	Horizontal	Pass
4**	7723.000	42.98	-1.35	54.0	11.02	AV	329.00	100	Horizontal	Pass
5	12822.500	45.49	1.32	74.0	28.51	Peak	138.00	400	Horizontal	Pass
5**	12822.500	37.05	1.32	54.0	16.95	AV	138.00	400	Horizontal	Pass
6	17577.501	48.87	6.14	74.0	25.13	Peak	71.00	100	Horizontal	Pass
6**	17577.501	40.71	6.14	54.0	13.29	AV	71.00	100	Horizontal	Pass

1 GHz to 18 GHz, ANT V 802.11n40 High Channel

No.	Frequency (MHz)	Results (dBuV/m)	Factor (dB)	Limit (dBuV/m)	Margin (dB)	Detector	Table (Degree)	Height (cm)	Antenna	Verdict
1	1330.100	42.27	-19.08	74.0	31.73	Peak	125.00	400	Vertical	Pass
1**	1330.100	30.95	-19.08	54.0	23.05	AV	125.00	400	Vertical	Pass
2	2455.000	91.50	-12.70	74.0	-17.50	Peak	142.00	150	Vertical	N/A
2**	2455.000	84.86	-12.70	54.0	-30.86	AV	142.00	150	Vertical	N/A
3	2784.600	49.59	-10.10	74.0	24.41	Peak	298.00	200	Vertical	Pass
3**	2784.600	41.33	-10.10	54.0	12.67	AV	298.00	200	Vertical	Pass
4	7767.250	52.57	-0.44	74.0	21.43	Peak	0.00	200	Vertical	Pass
4**	7767.250	44.73	-0.44	54.0	9.27	AV	0.00	200	Vertical	Pass
5	12795.000	45.14	1.97	74.0	28.86	Peak	16.00	300	Vertical	Pass
5**	12795.000	39.40	1.97	54.0	14.60	AV	16.00	300	Vertical	Pass
6	17799.999	47.52	6.52	74.0	26.48	Peak	251.00	400	Vertical	Pass
6**	17799.999	41.54	6.52	54.0	12.46	AV	251.00	400	Vertical	Pass

MIMO

1 GHz to 18 GHz, ANT H 802.11n20 Low Channel

No.	Frequency (MHz)	Results (dBuV/m)	Factor (dB)	Limit (dBuV/m)	Margin (dB)	Detector	Table (Degree)	Height (cm)	Antenna	Verdict
1	2256.100	48.08	-14.52	74.0	25.92	Peak	66.00	100	Horizontal	Pass
1**	2256.100	38.38	-14.52	54.0	15.62	AV	66.00	100	Horizontal	Pass
2	2411.800	103.36	-15.02	74.0	-29.36	Peak	188.00	200	Horizontal	N/A
2**	2411.800	96.18	-15.02	54.0	-42.18	AV	188.00	200	Horizontal	N/A
3	2571.200	49.32	-12.97	74.0	24.68	Peak	26.00	300	Horizontal	Pass
3**	2571.200	41.47	-12.97	54.0	12.53	AV	26.00	300	Horizontal	Pass
4	7805.000	52.79	0.04	74.0	21.21	Peak	292.00	200	Horizontal	Pass
4**	7805.000	43.82	0.04	54.0	10.18	AV	292.00	200	Horizontal	Pass
5	12792.500	45.63	1.94	74.0	28.37	Peak	55.00	100	Horizontal	Pass
5**	12792.500	38.10	1.94	54.0	15.90	AV	55.00	100	Horizontal	Pass
6	17542.500	47.70	6.36	74.0	26.30	Peak	10.00	200	Horizontal	Pass
6**	17542.500	39.65	6.36	54.0	14.35	AV	10.00	200	Horizontal	Pass

1 GHz to 18 GHz, ANT V 802.11n20 Low Channel

No.	Frequency (MHz)	Results (dBuV/m)	Factor (dB)	Limit (dBuV/m)	Margin (dB)	Detector	Table (Degree)	Height (cm)	Antenna	Verdict
1	1488.400	40.17	-19.40	74.0	33.83	Peak	208.00	300	Vertical	Pass
1**	1488.400	30.97	-19.40	54.0	23.03	AV	208.00	300	Vertical	Pass
2	2414.000	95.36	-14.72	74.0	-21.36	Peak	129.00	200	Vertical	N/A
2**	2414.000	87.51	-14.72	54.0	-33.51	AV	129.00	200	Vertical	N/A
3	2753.400	50.27	-11.17	74.0	23.73	Peak	138.00	100	Vertical	Pass
3**	2753.400	40.01	-11.17	54.0	13.99	AV	138.00	100	Vertical	Pass
4	7576.250	52.72	-0.46	74.0	21.28	Peak	360.00	200	Vertical	Pass
4**	7576.250	43.58	-0.46	54.0	10.42	AV	360.00	200	Vertical	Pass
5	12805.000	46.16	1.86	74.0	27.84	Peak	165.00	200	Vertical	Pass
5**	12805.000	37.23	1.86	54.0	16.77	AV	165.00	200	Vertical	Pass
6	17827.500	48.26	5.78	74.0	25.74	Peak	239.00	100	Vertical	Pass
6**	17827.500	40.30	5.78	54.0	13.70	AV	239.00	100	Vertical	Pass

1 GHz to 18 GHz, ANT H 802.11n20 Middle Channel

No.	Frequency (MHz)	Results (dBuV/m)	Factor (dB)	Limit (dBuV/m)	Margin (dB)	Detector	Table (Degree)	Height (cm)	Antenna	Verdict
1	2280.500	49.00	-15.01	74.0	25.00	Peak	334.00	100	Horizontal	Pass
1**	2280.500	39.95	-15.01	54.0	14.05	AV	334.00	100	Horizontal	Pass
2	2437.200	101.64	-14.60	74.0	-27.64	Peak	160.00	150	Horizontal	N/A
2**	2437.200	95.22	-14.60	54.0	-41.22	AV	160.00	150	Horizontal	N/A
3	2597.800	50.24	-13.55	74.0	23.76	Peak	38.00	100	Horizontal	Pass
3**	2597.800	41.60	-13.55	54.0	12.40	AV	38.00	100	Horizontal	Pass
4	7351.500	52.61	-1.11	74.0	21.39	Peak	96.00	400	Horizontal	Pass
4**	7351.500	43.16	-1.11	54.0	10.84	AV	96.00	400	Horizontal	Pass
5	12792.500	45.95	1.94	74.0	28.05	Peak	360.00	400	Horizontal	Pass
5**	12792.500	38.76	1.94	54.0	15.24	AV	360.00	400	Horizontal	Pass
6	17570.001	49.15	6.24	74.0	24.85	Peak	110.00	200	Horizontal	Pass
6**	17570.001	40.80	6.24	54.0	13.20	AV	110.00	200	Horizontal	Pass

1 GHz to 18 GHz, ANT V 802.11n20 Middle Channel

No.	Frequency (MHz)	Results (dBuV/m)	Factor (dB)	Limit (dBuV/m)	Margin (dB)	Detector	Table (Degree)	Height (cm)	Antenna	Verdict
1	1358.900	40.22	-19.19	74.0	33.78	Peak	237.00	300	Vertical	Pass
1**	1358.900	30.35	-19.19	54.0	23.65	AV	237.00	300	Vertical	Pass
2	2438.000	94.25	-14.51	74.0	-20.25	Peak	272.00	150	Vertical	N/A
2**	2438.000	86.82	-14.51	54.0	-32.82	AV	272.00	150	Vertical	N/A
3	2786.600	49.89	-9.92	74.0	24.11	Peak	0.00	100	Vertical	Pass
3**	2786.600	41.81	-9.92	54.0	12.19	AV	0.00	100	Vertical	Pass
4	7760.000	52.65	-0.32	74.0	21.35	Peak	52.00	400	Vertical	Pass
4**	7760.000	43.74	-0.32	54.0	10.26	AV	52.00	400	Vertical	Pass
5	12790.000	45.32	1.92	74.0	28.68	Peak	261.00	400	Vertical	Pass
5**	12790.000	38.90	1.92	54.0	15.10	AV	261.00	400	Vertical	Pass
6	17789.999	48.24	6.22	74.0	25.76	Peak	319.00	100	Vertical	Pass
6**	17789.999	41.05	6.22	54.0	12.95	AV	319.00	100	Vertical	Pass

1 GHz to 18 GHz, ANT H 802.11n20 High Channel

No.	Frequency (MHz)	Results (dBuV/m)	Factor (dB)	Limit (dBuV/m)	Margin (dB)	Detector	Table (Degree)	Height (cm)	Antenna	Verdict
1	2302.400	48.34	-15.20	74.0	25.66	Peak	68.00	100	Horizontal	Pass
1**	2302.400	41.21	-15.20	54.0	12.79	AV	68.00	100	Horizontal	Pass
2	2462.300	105.19	-13.94	74.0	-31.19	Peak	51.00	150	Horizontal	N/A
2**	2462.300	98.17	-13.94	54.0	-44.17	AV	51.00	150	Horizontal	N/A
3	2787.000	50.70	-10.28	74.0	23.30	Peak	51.00	100	Horizontal	Pass
3**	2787.000	41.66	-10.28	54.0	12.34	AV	51.00	100	Horizontal	Pass
4	7923.000	52.47	-0.51	74.0	21.53	Peak	155.00	400	Horizontal	Pass
4**	7923.000	42.75	-0.51	54.0	11.25	AV	155.00	400	Horizontal	Pass
5	12792.500	46.25	1.94	74.0	27.75	Peak	17.00	300	Horizontal	Pass
5**	12792.500	38.49	1.94	54.0	15.51	AV	17.00	300	Horizontal	Pass
6	17554.999	47.59	6.44	74.0	26.41	Peak	8.00	200	Horizontal	Pass
6**	17554.999	39.96	6.44	54.0	14.04	AV	8.00	200	Horizontal	Pass

1 GHz to 18 GHz, ANT V 802.11n20 High Channel

No.	Frequency (MHz)	Results (dBuV/m)	Factor (dB)	Limit (dBuV/m)	Margin (dB)	Detector	Table (Degree)	Height (cm)	Antenna	Verdict
1	1464.700	40.18	-19.92	74.0	33.82	Peak	202.00	200	Vertical	Pass
1**	1464.700	29.91	-19.92	54.0	24.09	AV	202.00	200	Vertical	Pass
2	2458.000	97.92	-13.45	74.0	-23.92	Peak	265.00	200	Vertical	N/A
2**	2458.000	90.60	-13.45	54.0	-36.60	AV	265.00	200	Vertical	N/A
3	2785.000	50.02	-9.91	74.0	23.98	Peak	210.00	150	Vertical	Pass
3**	2785.000	42.06	-9.91	54.0	11.94	AV	210.00	150	Vertical	Pass
4	7916.500	52.96	0.12	74.0	21.04	Peak	181.00	200	Vertical	Pass
4**	7916.500	43.79	0.12	54.0	10.21	AV	181.00	200	Vertical	Pass
5	12272.500	45.99	0.49	74.0	28.01	Peak	228.00	300	Vertical	Pass
5**	12272.500	37.19	0.49	54.0	16.81	AV	228.00	300	Vertical	Pass
6	17802.500	48.36	6.46	74.0	25.64	Peak	52.00	100	Vertical	Pass
6**	17802.500	41.02	6.46	54.0	12.98	AV	52.00	100	Vertical	Pass

1 GHz to 18 GHz, ANT H 802.11n40 Low Channel

No.	Frequency (MHz)	Results (dBuV/m)	Factor (dB)	Limit (dBuV/m)	Margin (dB)	Detector	Table (Degree)	Height (cm)	Antenna	Verdict
1	1439.300	41.19	-19.66	74.0	32.81	Peak	160.00	400	Horizontal	Pass
1**	1439.300	29.93	-19.66	54.0	24.07	AV	160.00	400	Horizontal	Pass
2	2424.800	95.77	-14.31	74.0	-21.77	Peak	13.00	200	Horizontal	N/A
2**	2424.800	88.21	-14.31	54.0	-34.21	AV	13.00	200	Horizontal	N/A
3	2970.000	49.72	-11.07	74.0	24.28	Peak	305.00	150	Horizontal	Pass
3**	2970.000	39.60	-11.07	54.0	14.40	AV	305.00	150	Horizontal	Pass
4	7583.000	53.02	0.28	74.0	20.98	Peak	89.00	200	Horizontal	Pass
4**	7583.000	45.25	0.28	54.0	8.75	AV	89.00	200	Horizontal	Pass
5	12767.500	46.52	1.70	74.0	27.48	Peak	360.00	300	Horizontal	Pass
5**	12767.500	37.85	1.70	54.0	16.15	AV	360.00	300	Horizontal	Pass
6	17805.001	48.31	6.39	74.0	25.69	Peak	199.00	200	Horizontal	Pass
6**	17805.001	40.63	6.39	54.0	13.37	AV	199.00	200	Horizontal	Pass

1 GHz to 18 GHz, ANT V 802.11n40 Low Channel

No.	Frequency (MHz)	Results (dBuV/m)	Factor (dB)	Limit (dBuV/m)	Margin (dB)	Detector	Table (Degree)	Height (cm)	Antenna	Verdict
1	1497.100	39.91	-18.67	74.0	34.09	Peak	150.00	300	Vertical	Pass
1**	1497.100	31.23	-18.67	54.0	22.77	AV	150.00	300	Vertical	Pass
2	2425.500	82.58	-14.22	74.0	-8.58	Peak	264.00	200	Vertical	N/A
2**	2425.500	75.33	-14.22	54.0	-21.33	AV	264.00	200	Vertical	N/A
3	2778.800	50.09	-10.39	74.0	23.91	Peak	237.00	150	Vertical	Pass
3**	2778.800	40.53	-10.39	54.0	13.47	AV	237.00	150	Vertical	Pass
4	7325.250	52.68	-1.39	74.0	21.32	Peak	246.00	400	Vertical	Pass
4**	7325.250	43.51	-1.39	54.0	10.49	AV	246.00	400	Vertical	Pass
5	12805.000	46.09	1.86	74.0	27.91	Peak	270.00	400	Vertical	Pass
5**	12805.000	38.00	1.86	54.0	16.00	AV	270.00	400	Vertical	Pass
6	17824.999	48.54	5.85	74.0	25.46	Peak	149.00	300	Vertical	Pass
6**	17824.999	41.07	5.85	54.0	12.93	AV	149.00	300	Vertical	Pass

1 GHz to 18 GHz, ANT H 802.11n40 Middle Channel

No.	Frequency (MHz)	Results (dBuV/m)	Factor (dB)	Limit (dBuV/m)	Margin (dB)	Detector	Table (Degree)	Height (cm)	Antenna	Verdict
1	1439.100	41.13	-19.78	74.0	32.87	Peak	201.00	100	Horizontal	Pass
1**	1439.100	30.26	-19.78	54.0	23.74	AV	201.00	100	Horizontal	Pass
2	2440.900	99.20	-14.23	74.0	-25.20	Peak	172.00	200	Horizontal	N/A
2**	2440.900	92.20	-14.23	54.0	-38.20	AV	172.00	200	Horizontal	N/A
3	2784.800	49.52	-9.79	74.0	24.48	Peak	172.00	100	Horizontal	Pass
3**	2784.800	41.58	-9.79	54.0	12.42	AV	172.00	100	Horizontal	Pass
4	7759.000	53.55	-0.17	74.0	20.45	Peak	360.00	300	Horizontal	Pass
4**	7759.000	43.70	-0.17	54.0	10.30	AV	360.00	300	Horizontal	Pass
5	12755.000	45.78	1.58	74.0	28.22	Peak	64.00	200	Horizontal	Pass
5**	12755.000	37.50	1.58	54.0	16.50	AV	64.00	200	Horizontal	Pass
6	17820.000	48.92	5.98	74.0	25.08	Peak	325.00	400	Horizontal	Pass
6**	17820.000	41.07	5.98	54.0	12.93	AV	325.00	400	Horizontal	Pass

1 GHz to 18 GHz, ANT V 802.11n40 Middle Channel

No.	Frequency (MHz)	Results (dBuV/m)	Factor (dB)	Limit (dBuV/m)	Margin (dB)	Detector	Table (Degree)	Height (cm)	Antenna	Verdict
1	1448.700	40.02	-19.73	74.0	33.98	Peak	23.00	200	Vertical	Pass
1**	1448.700	31.14	-19.73	54.0	22.86	AV	23.00	200	Vertical	Pass
2	2445.900	89.98	-13.92	74.0	-15.98	Peak	258.00	150	Vertical	N/A
2**	2445.900	82.89	-13.92	54.0	-28.89	AV	258.00	150	Vertical	N/A
3	2783.200	49.66	-9.54	74.0	24.34	Peak	23.00	100	Vertical	Pass
3**	2783.200	41.85	-9.54	54.0	12.15	AV	23.00	100	Vertical	Pass
4	7772.750	52.61	-0.55	74.0	21.39	Peak	286.00	200	Vertical	Pass
4**	7772.750	43.90	-0.55	54.0	10.10	AV	286.00	200	Vertical	Pass
5	12792.500	45.24	1.94	74.0	28.76	Peak	222.00	400	Vertical	Pass
5**	12792.500	38.31	1.94	54.0	15.69	AV	222.00	400	Vertical	Pass
6	17552.501	47.78	6.47	74.0	26.22	Peak	222.00	100	Vertical	Pass
6**	17552.501	39.86	6.47	54.0	14.14	AV	222.00	100	Vertical	Pass

1 GHz to 18 GHz, ANT H 802.11n40 High Channel

No.	Frequency (MHz)	Results (dBuV/m)	Factor (dB)	Limit (dBuV/m)	Margin (dB)	Detector	Table (Degree)	Height (cm)	Antenna	Verdict
1	1445.300	41.06	-19.87	74.0	32.94	Peak	189.00	200	Horizontal	Pass
1**	1445.300	30.44	-19.87	54.0	23.56	AV	189.00	200	Horizontal	Pass
2	2455.000	98.86	-12.70	74.0	-24.86	Peak	161.00	100	Horizontal	N/A
2**	2455.000	91.68	-12.70	54.0	-37.68	AV	161.00	100	Horizontal	N/A
3	2783.200	50.06	-9.54	74.0	23.94	Peak	189.00	200	Horizontal	Pass
3**	2783.200	41.66	-9.54	54.0	12.34	AV	189.00	200	Horizontal	Pass
4	7764.750	53.14	-0.17	74.0	20.86	Peak	142.00	100	Horizontal	Pass
4**	7764.750	45.01	-0.17	54.0	8.99	AV	142.00	100	Horizontal	Pass
5	12742.500	45.57	1.38	74.0	28.43	Peak	49.00	300	Horizontal	Pass
5**	12742.500	37.10	1.38	54.0	16.90	AV	49.00	300	Horizontal	Pass
6	17529.999	47.46	6.12	74.0	26.54	Peak	156.00	400	Horizontal	Pass
6**	17529.999	40.56	6.12	54.0	13.44	AV	156.00	400	Horizontal	Pass

1 GHz to 18 GHz, ANT V 802.11n40 High Channel

No.	Frequency (MHz)	Results (dBuV/m)	Factor (dB)	Limit (dBuV/m)	Margin (dB)	Detector	Table (Degree)	Height (cm)	Antenna	Verdict
1	1501.500	40.29	-19.59	74.0	33.71	Peak	256.00	400	Vertical	Pass
1**	1501.500	31.25	-19.59	54.0	22.75	AV	256.00	400	Vertical	Pass
2	2454.900	90.24	-12.94	74.0	-16.24	Peak	265.00	150	Vertical	N/A
2**	2454.900	82.89	-12.94	54.0	-28.89	AV	265.00	150	Vertical	N/A
3	2776.300	50.91	-10.68	74.0	23.09	Peak	360.00	100	Vertical	Pass
3**	2776.300	42.10	-10.68	54.0	11.90	AV	360.00	100	Vertical	Pass
4	7582.250	52.69	-0.05	74.0	21.31	Peak	291.00	300	Vertical	Pass
4**	7582.250	43.18	-0.05	54.0	10.82	AV	291.00	300	Vertical	Pass
5	12787.500	45.57	1.89	74.0	28.43	Peak	180.00	100	Vertical	Pass
5**	12787.500	38.70	1.89	54.0	15.30	AV	180.00	100	Vertical	Pass
6	17582.500	48.42	6.08	74.0	25.58	Peak	248.00	400	Vertical	Pass
6**	17582.500	39.80	6.08	54.0	14.20	AV	248.00	400	Vertical	Pass

A.7 Band Edge (Restricted-band band-edge)

Note ¹: The lowest and highest channels are tested to verify the band edge emissions. Please refer to the following the plots for emissions values.

Note ²: The test data all are tested in the vertical and horizontal antenna which the trace is max hold. So these plots have shown the worst case.

Note ³: According the ANSI C63.10-2013, where limits are specified for both average and peak (or quasi-peak) detector functions, if the peak (or quasi-peak) measured value complies with the average limit, it is unnecessary to perform an average measurement.

Note ⁴: All the configurations were pre tested, only the worst configuration has been reported in this report.

Test Data and Plots

Main Antenna

802.11b LOW CHANNEL

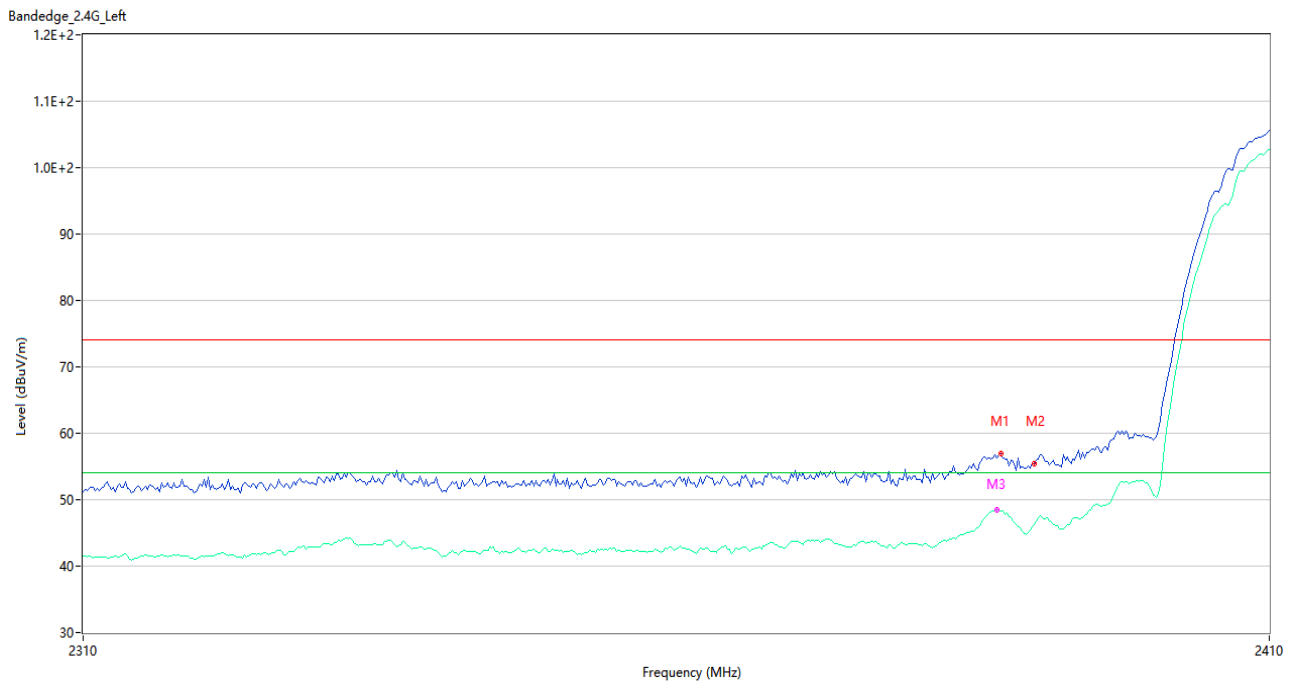

No.	Frequency (MHz)	Results (dBuV/m)	Factor (dB)	Limit (dBuV/m)	Margin (dB)	Detector	Table (Degree)	Height (cm)	Antenna	Verdict
1	2387.000	56.92	-2.66	74.0	17.08	Peak	51.00	100	Horizontal	Pass
1**	2387.000	48.39	-2.66	54.0	5.61	AV	51.00	100	Horizontal	Pass
2	2389.833	55.46	-3.45	74.0	18.54	Peak	333.00	100	Horizontal	Pass
2**	2389.833	46.31	-3.45	54.0	7.69	AV	333.00	100	Horizontal	Pass
3	2386.667	56.30	-2.86	74.0	17.70	Peak	72.00	200	Horizontal	Pass
3**	2386.667	48.40	-2.86	54.0	5.60	AV	72.00	200	Horizontal	Pass

802.11b HIGH CHANNEL

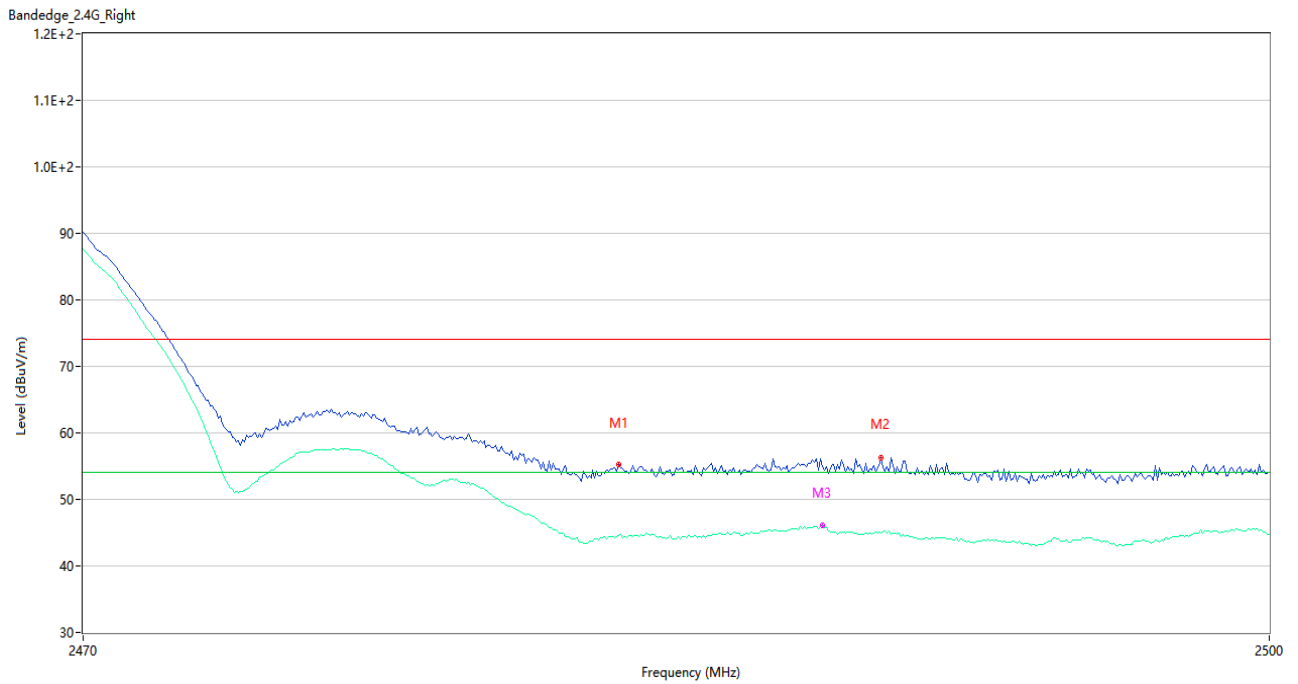

No.	Frequency (MHz)	Results (dBuV/m)	Factor (dB)	Limit (dBuV/m)	Margin (dB)	Detector	Table (Degree)	Height (cm)	Antenna	Verdict
1	2483.500	55.21	-2.54	74.0	18.79	Peak	47.00	200	Horizontal	Pass
1**	2483.500	44.50	-2.54	54.0	9.50	AV	47.00	200	Horizontal	Pass
2	2490.150	56.28	-2.34	74.0	17.72	Peak	43.00	150	Horizontal	Pass
2**	2490.150	44.91	-2.34	54.0	9.09	AV	43.00	150	Horizontal	Pass
3	2488.650	54.92	-2.58	74.0	19.08	Peak	194.00	100	Horizontal	Pass
3**	2488.650	46.05	-2.58	54.0	7.95	AV	194.00	100	Horizontal	Pass

802.11g LOW CHANNEL

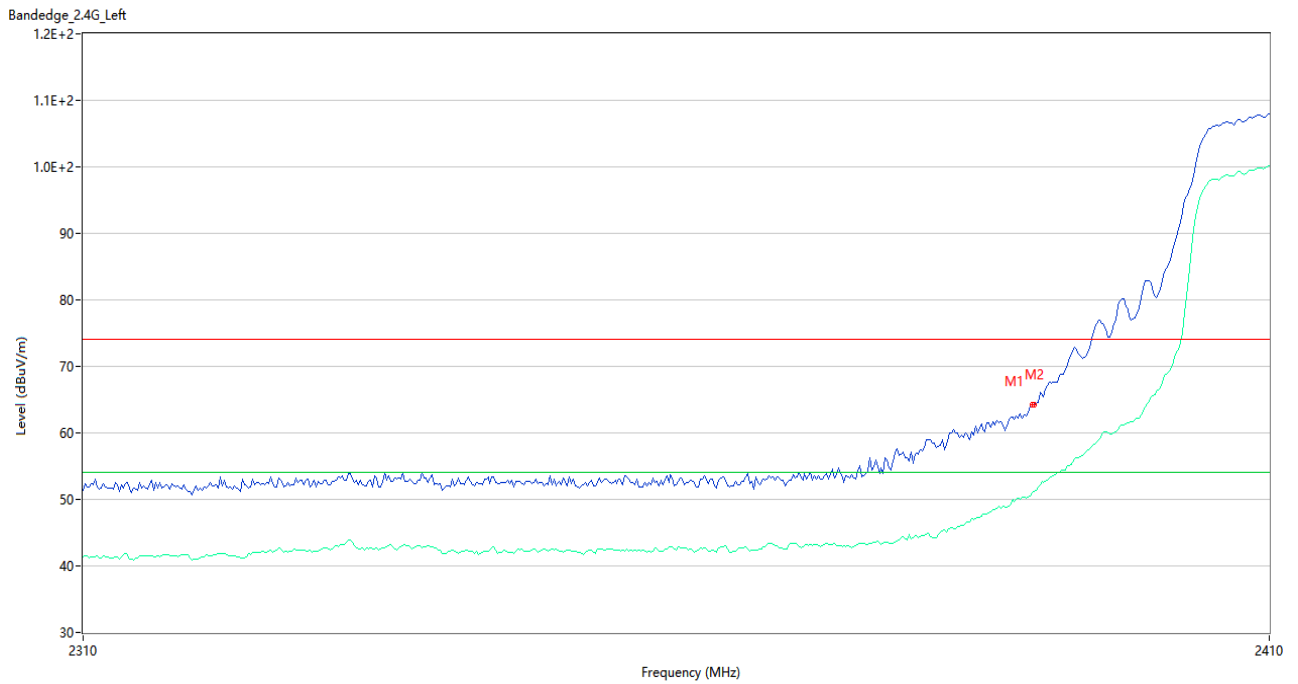

No.	Frequency (MHz)	Results (dBuV/m)	Factor (dB)	Limit (dBuV/m)	Margin (dB)	Detector	Table (Degree)	Height (cm)	Antenna	Verdict
1	2389.667	64.16	-3.36	74.0	9.84	Peak	53.00	200	Horizontal	Pass
1**	2389.667	51.06	-3.36	54.0	2.94	AV	53.00	200	Horizontal	Pass
2	2389.833	64.31	-3.45	74.0	9.69	Peak	53.00	150	Horizontal	Pass
2**	2389.833	51.18	-3.45	54.0	2.82	AV	53.00	150	Horizontal	Pass

802.11g HIGH CHANNEL

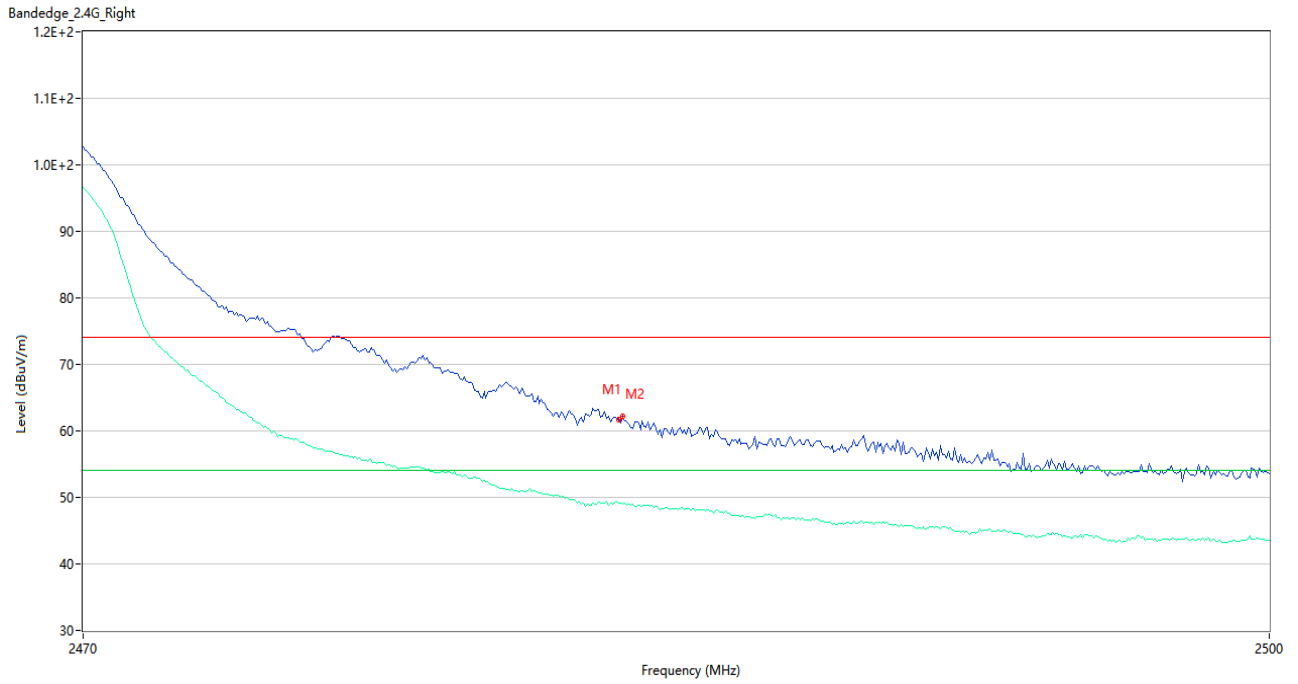

No.	Frequency (MHz)	Results (dBuV/m)	Factor (dB)	Limit (dBuV/m)	Margin (dB)	Detector	Table (Degree)	Height (cm)	Antenna	Verdict
1	2483.500	61.76	-2.54	74.0	12.24	Peak	46.00	150	Horizontal	Pass
1**	2483.500	49.17	-2.54	54.0	4.83	AV	46.00	150	Horizontal	Pass
2	2483.600	62.21	-2.59	74.0	11.79	Peak	52.00	100	Horizontal	Pass
2**	2483.600	49.03	-2.59	54.0	4.97	AV	52.00	100	Horizontal	Pass

802.11n20 LOW CHANNEL

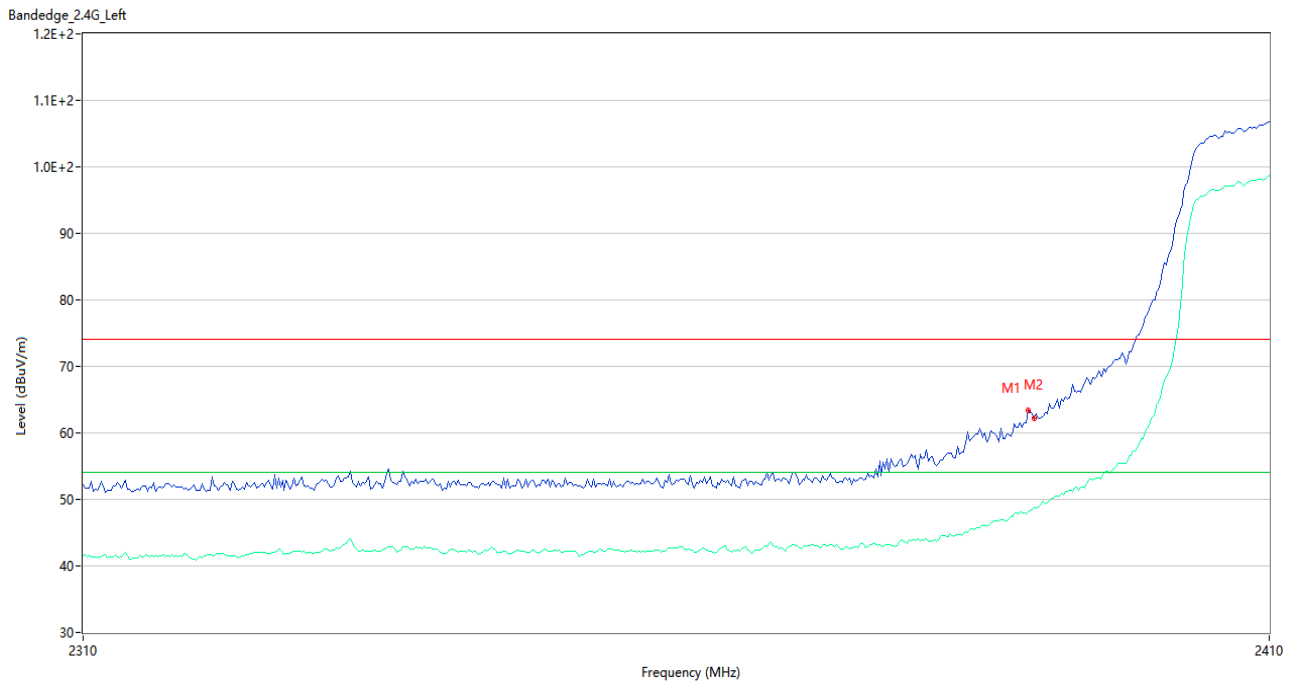

No.	Frequency (MHz)	Results (dBuV/m)	Factor (dB)	Limit (dBuV/m)	Margin (dB)	Detector	Table (Degree)	Height (cm)	Antenna	Verdict
1	2389.333	63.37	-3.45	74.0	10.63	Peak	49.00	100	Horizontal	Pass
1**	2389.333	48.16	-3.45	54.0	5.84	AV	49.00	100	Horizontal	Pass
2	2389.833	62.27	-3.45	74.0	11.73	Peak	360.00	100	Horizontal	Pass
2**	2389.833	48.75	-3.45	54.0	5.25	AV	360.00	100	Horizontal	Pass

802.11n20 HIGH CHANNEL

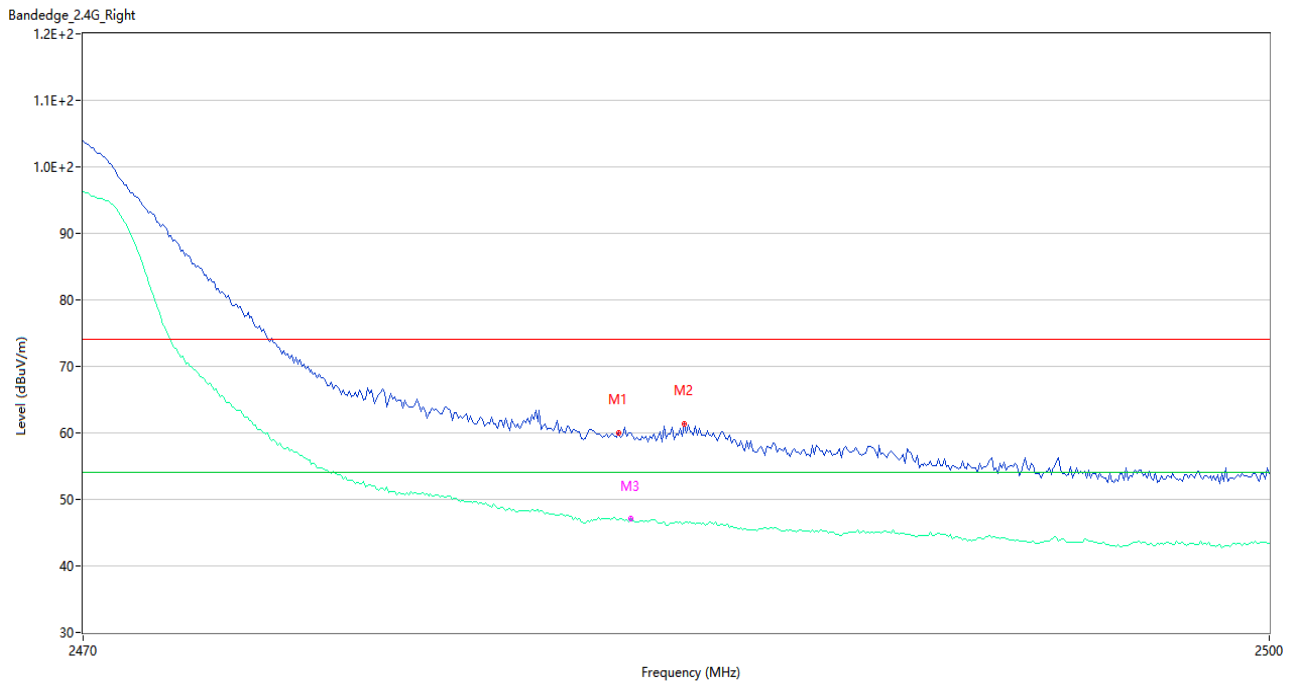

No.	Frequency (MHz)	Results (dBuV/m)	Factor (dB)	Limit (dBuV/m)	Margin (dB)	Detector	Table (Degree)	Height (cm)	Antenna	Verdict
1	2483.500	60.00	-2.54	74.0	14.00	Peak	46.00	150	Horizontal	Pass
1**	2483.500	46.95	-2.54	54.0	7.05	AV	46.00	150	Horizontal	Pass
2	2485.150	61.38	-2.40	74.0	12.62	Peak	49.00	100	Horizontal	Pass
2**	2485.150	46.49	-2.40	54.0	7.51	AV	49.00	100	Horizontal	Pass
3	2483.800	59.97	-2.68	74.0	14.03	Peak	43.00	200	Horizontal	Pass
3**	2483.800	47.14	-2.68	54.0	6.86	AV	43.00	200	Horizontal	Pass

802.11n40 LOW CHANNEL

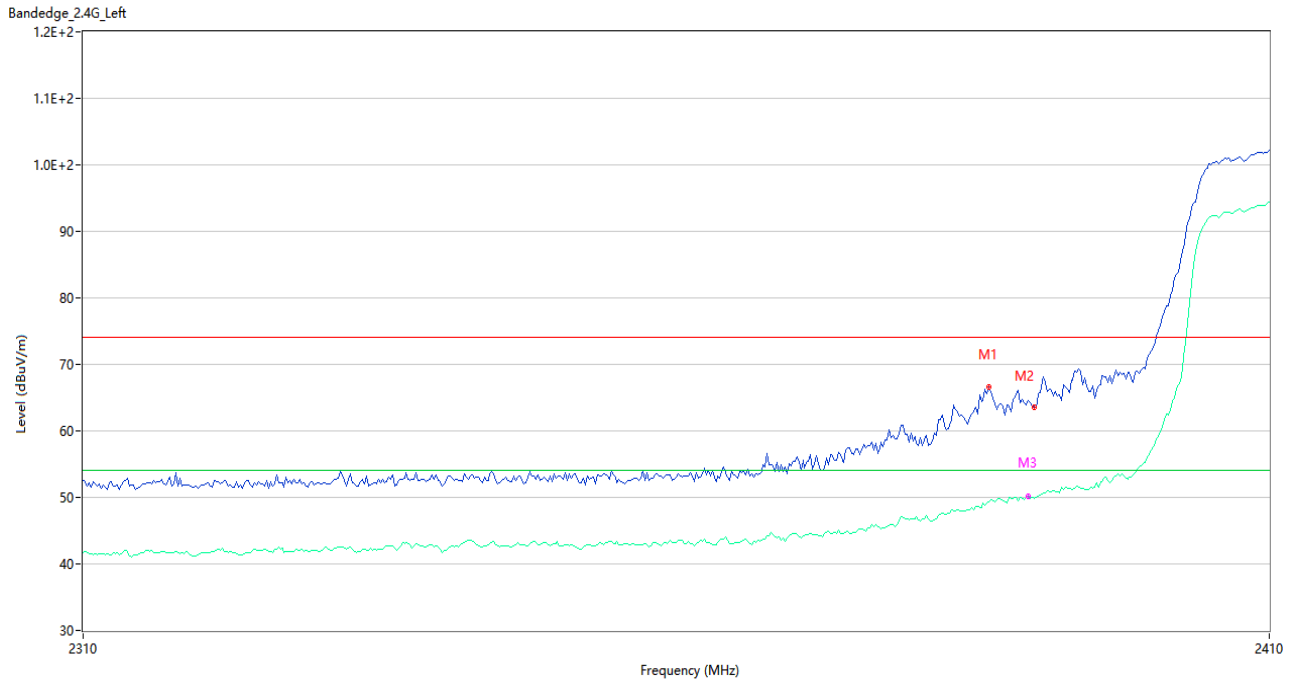

No.	Frequency (MHz)	Results (dBuV/m)	Factor (dB)	Limit (dBuV/m)	Margin (dB)	Detector	Table (Degree)	Height (cm)	Antenna	Verdict
1	2386.000	66.56	-2.98	74.0	7.44	Peak	60.00	200	Horizontal	Pass
1**	2386.000	49.35	-2.98	54.0	4.65	AV	60.00	200	Horizontal	Pass
2	2389.833	63.64	-3.45	74.0	10.36	Peak	48.00	100	Horizontal	Pass
2**	2389.833	49.83	-3.45	54.0	4.17	AV	48.00	100	Horizontal	Pass
3	2389.333	64.65	-3.45	74.0	9.35	Peak	53.00	100	Horizontal	Pass
3**	2389.333	50.18	-3.45	54.0	3.82	AV	53.00	100	Horizontal	Pass

802.11n40 HIGH CHANNEL

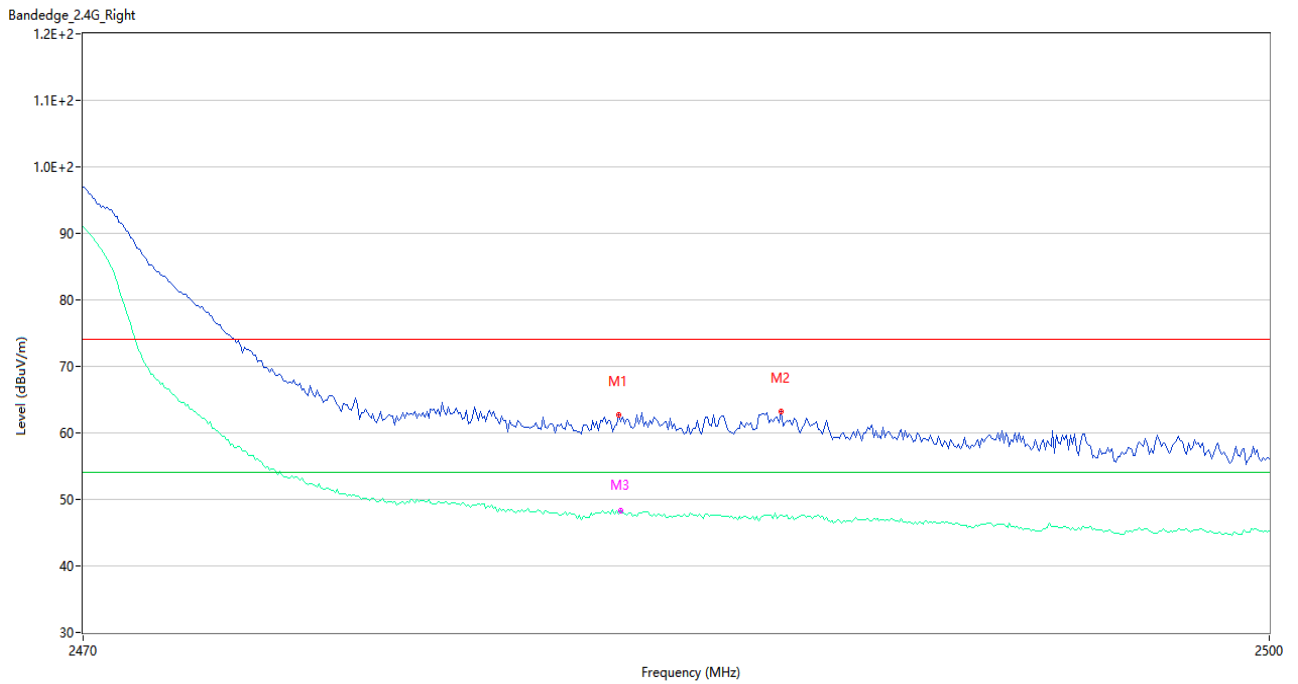

No.	Frequency (MHz)	Results (dBuV/m)	Factor (dB)	Limit (dBuV/m)	Margin (dB)	Detector	Table (Degree)	Height (cm)	Antenna	Verdict
1	2483.500	62.74	-2.54	74.0	11.26	Peak	49.00	150	Horizontal	Pass
1**	2483.500	47.86	-2.54	54.0	6.14	AV	49.00	150	Horizontal	Pass
2	2487.600	63.25	-2.65	74.0	10.75	Peak	52.00	150	Horizontal	Pass
2**	2487.600	47.55	-2.65	54.0	6.45	AV	52.00	150	Horizontal	Pass
3	2483.550	61.67	-2.56	74.0	12.33	Peak	49.00	200	Horizontal	Pass
3**	2483.550	48.35	-2.56	54.0	5.65	AV	49.00	200	Horizontal	Pass

Aux. Antenna

802.11b LOW CHANNEL

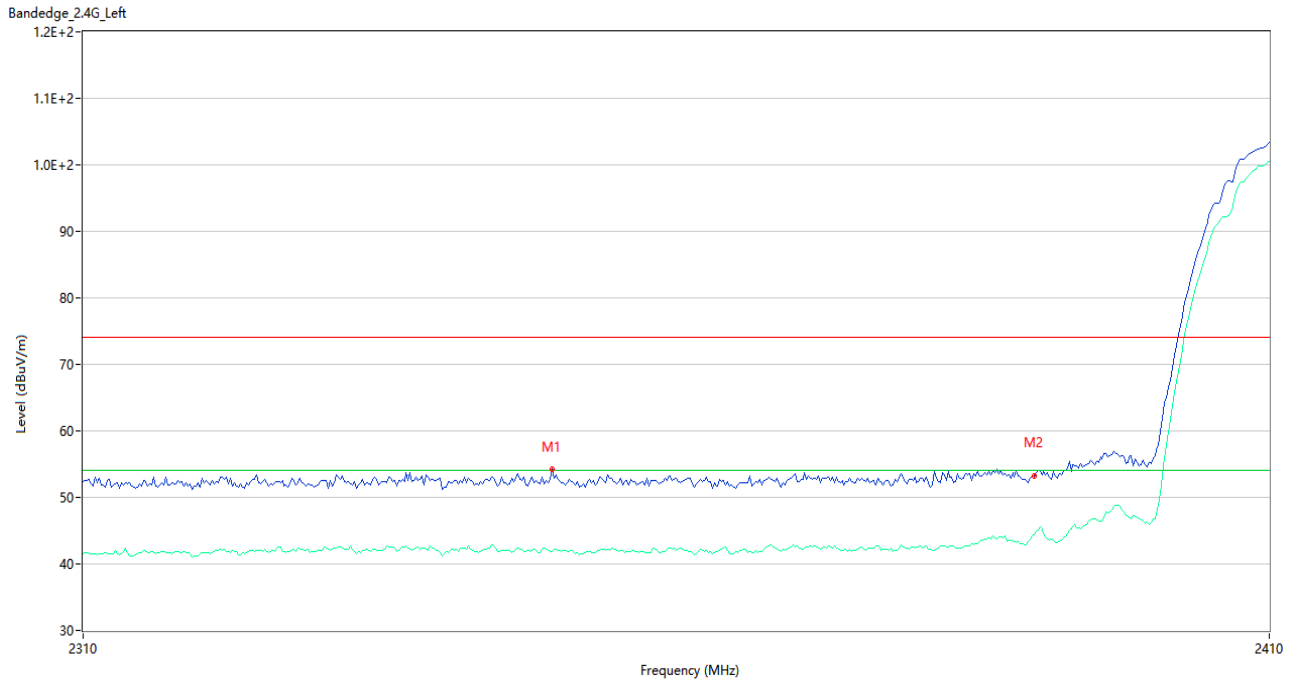

No.	Frequency (MHz)	Results (dBuV/m)	Factor (dB)	Limit (dBuV/m)	Margin (dB)	Detector	Table (Degree)	Height (cm)	Antenna	Verdict
1	2349.000	54.29	-3.02	74.0	19.71	Peak	342.00	100	Horizontal	Pass
1**	2349.000	41.91	-3.02	54.0	12.09	AV	342.00	100	Horizontal	Pass
2	2389.833	53.30	-3.45	74.0	20.70	Peak	189.00	200	Horizontal	Pass
2**	2389.833	44.45	-3.45	54.0	9.55	AV	189.00	200	Horizontal	Pass

802.11b HIGH CHANNEL

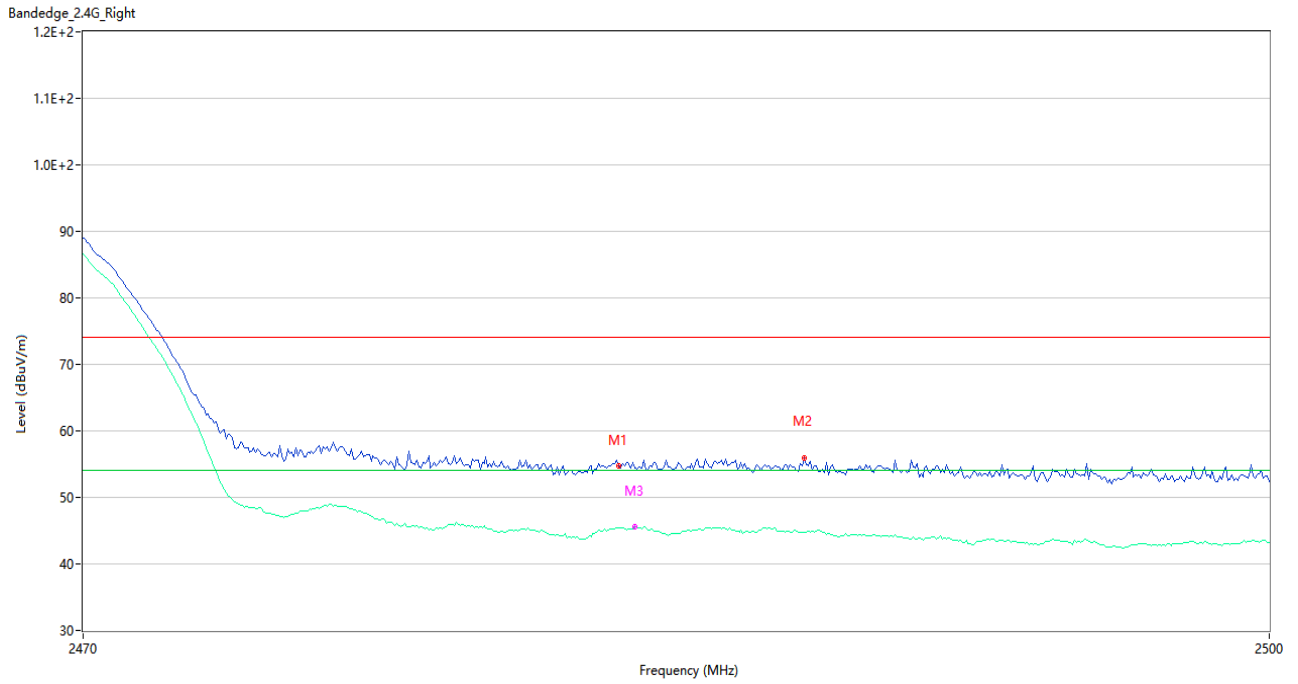

No.	Frequency (MHz)	Results (dBuV/m)	Factor (dB)	Limit (dBuV/m)	Margin (dB)	Detector	Table (Degree)	Height (cm)	Antenna	Verdict
1	2483.500	54.68	-2.54	74.0	19.32	Peak	199.00	200	Horizontal	Pass
1**	2483.500	45.35	-2.54	54.0	8.65	AV	199.00	200	Horizontal	Pass
2	2488.200	55.93	-2.65	74.0	18.07	Peak	168.00	150	Horizontal	Pass
2**	2488.200	44.77	-2.65	54.0	9.23	AV	168.00	150	Horizontal	Pass
3	2483.900	54.44	-2.72	74.0	19.56	Peak	199.00	100	Horizontal	Pass
3**	2483.900	45.60	-2.72	54.0	8.40	AV	199.00	100	Horizontal	Pass

802.11g LOW CHANNEL

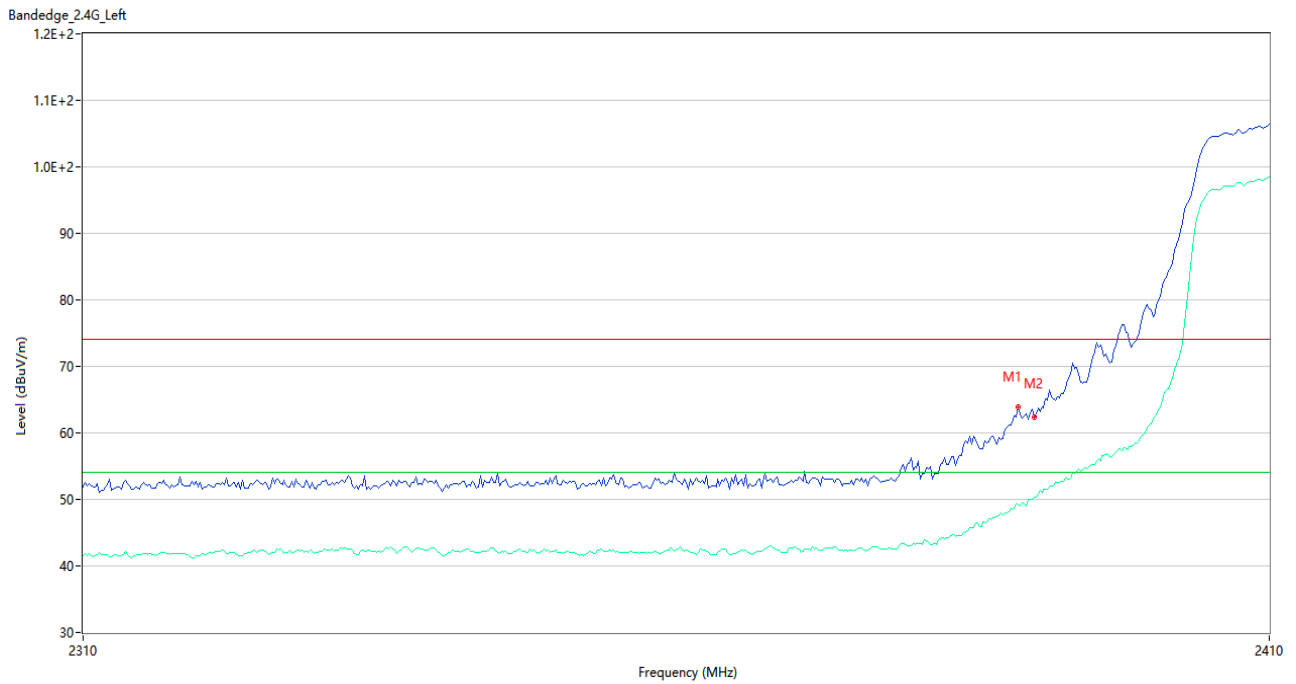

No.	Frequency (MHz)	Results (dBuV/m)	Factor (dB)	Limit (dBuV/m)	Margin (dB)	Detector	Table (Degree)	Height (cm)	Antenna	Verdict
1	2388.500	63.84	-3.02	74.0	10.16	Peak	163.00	100	Horizontal	Pass
1**	2388.500	49.13	-3.02	54.0	4.87	AV	163.00	100	Horizontal	Pass
2	2389.833	62.39	-3.45	74.0	11.61	Peak	163.00	200	Horizontal	Pass
2**	2389.833	50.35	-3.45	54.0	3.65	AV	163.00	200	Horizontal	Pass

802.11g HIGH CHANNEL

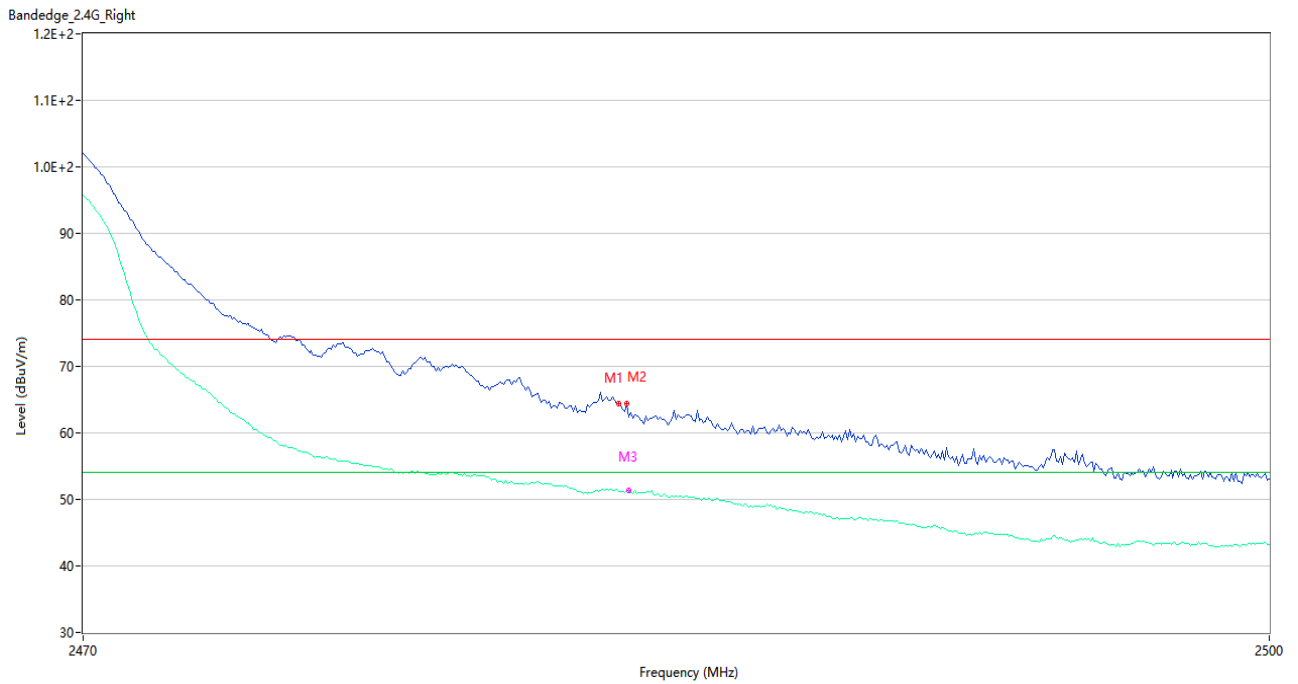

No.	Frequency (MHz)	Results (dBuV/m)	Factor (dB)	Limit (dBuV/m)	Margin (dB)	Detector	Table (Degree)	Height (cm)	Antenna	Verdict
1	2483.500	64.39	-2.54	74.0	9.61	Peak	187.00	100	Horizontal	Pass
1**	2483.500	51.19	-2.54	54.0	2.81	AV	187.00	100	Horizontal	Pass
2	2483.700	64.43	-2.63	74.0	9.57	Peak	189.00	200	Horizontal	Pass
2**	2483.700	51.23	-2.63	54.0	2.77	AV	189.00	200	Horizontal	Pass
3	2483.750	62.42	-2.65	74.0	11.58	Peak	189.00	100	Horizontal	Pass
3**	2483.750	51.32	-2.65	54.0	2.68	AV	189.00	100	Horizontal	Pass

802.11n20 LOW CHANNEL

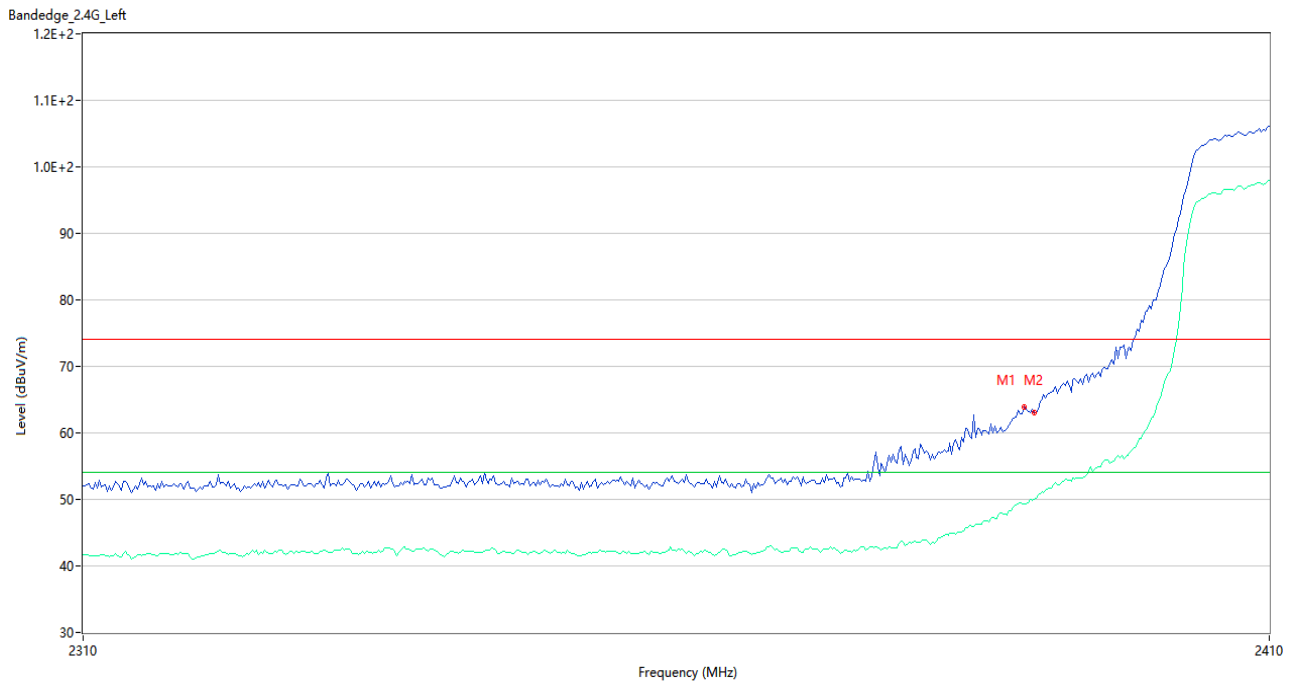

No.	Frequency (MHz)	Results (dBuV/m)	Factor (dB)	Limit (dBuV/m)	Margin (dB)	Detector	Table (Degree)	Height (cm)	Antenna	Verdict
1	2389.000	63.95	-3.43	74.0	10.05	Peak	162.00	100	Horizontal	Pass
1**	2389.000	49.33	-3.43	54.0	4.67	AV	162.00	100	Horizontal	Pass
2	2389.833	63.03	-3.45	74.0	10.97	Peak	162.00	200	Horizontal	Pass
2**	2389.833	50.07	-3.45	54.0	3.93	AV	162.00	200	Horizontal	Pass

802.11n20 HIGH CHANNEL

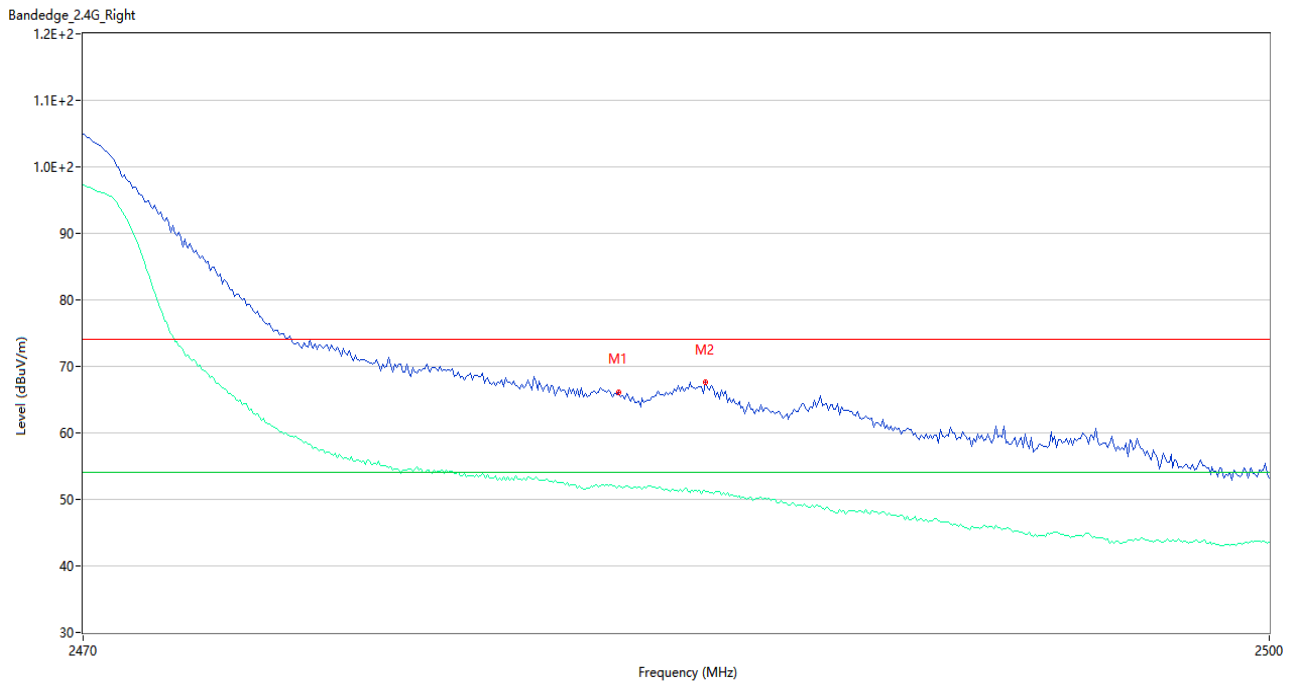

No.	Frequency (MHz)	Results (dBuV/m)	Factor (dB)	Limit (dBuV/m)	Margin (dB)	Detector	Table (Degree)	Height (cm)	Antenna	Verdict
1	2483.500	66.17	-2.54	74.0	7.83	Peak	199.00	150	Horizontal	Pass
1**	2483.500	52.03	-2.54	54.0	1.97	AV	199.00	150	Horizontal	Pass
2	2485.700	67.62	-2.51	74.0	6.38	Peak	194.00	150	Horizontal	Pass
2**	2485.700	51.12	-2.51	54.0	2.88	AV	194.00	150	Horizontal	Pass

802.11n40 LOW CHANNEL

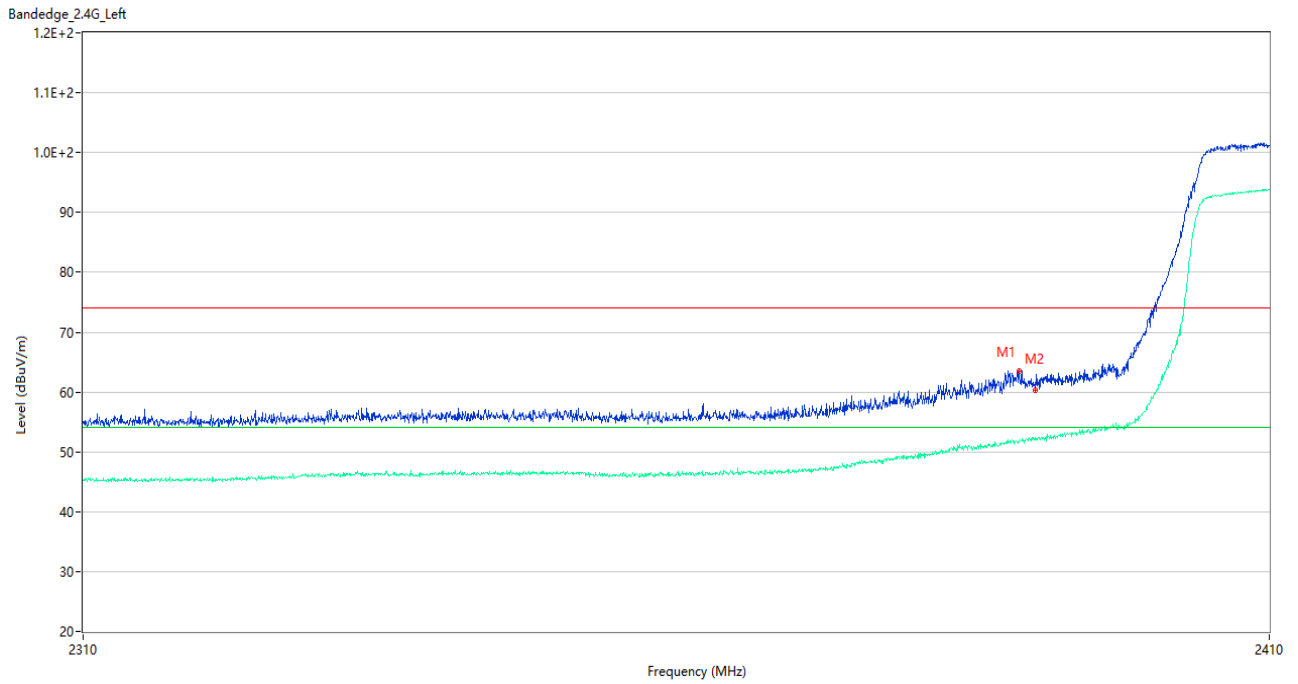

No.	Frequency (MHz)	Results (dBuV/m)	Factor (dB)	Limit (dBuV/m)	Margin (dB)	Detector	Table (Degree)	Height (cm)	Antenna	Verdict
1	2388.550	63.54	1.95	74.0	10.46	Peak	52.00	150	Horizontal	Pass
1**	2388.550	51.69	1.95	54.0	2.31	AV	52.00	150	Horizontal	Pass
2	2389.950	60.31	1.86	74.0	13.69	Peak	45.00	200	Horizontal	Pass
2**	2389.950	52.02	1.86	54.0	1.98	AV	45.00	200	Horizontal	Pass

802.11n40 HIGH CHANNEL

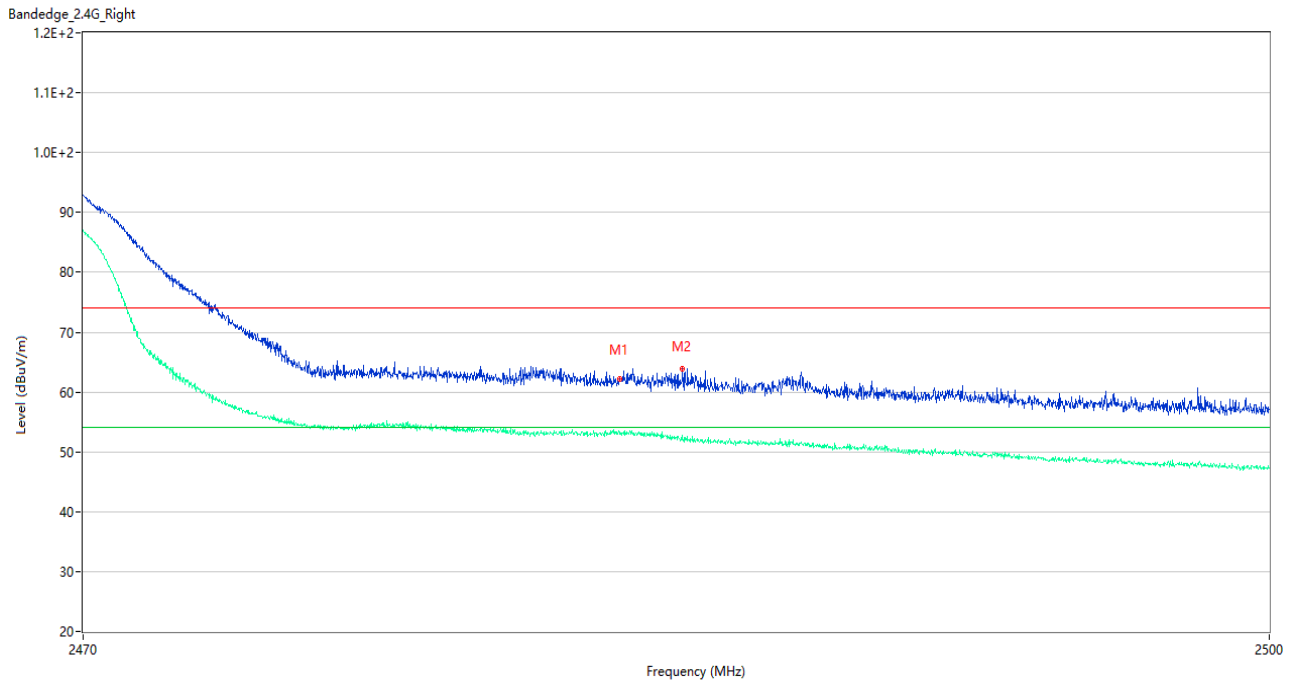

No.	Frequency (MHz)	Results (dBuV/m)	Factor (dB)	Limit (dBuV/m)	Margin (dB)	Detector	Table (Degree)	Height (cm)	Antenna	Verdict
1	2483.515	62.15	1.77	74.0	11.85	Peak	159.00	100	Horizontal	Pass
1**	2483.515	52.91	1.77	54.0	1.09	AV	159.00	100	Horizontal	Pass
2	2485.120	63.95	1.74	74.0	10.05	Peak	154.00	100	Horizontal	Pass
2**	2485.120	52.24	1.74	54.0	1.76	AV	154.00	100	Horizontal	Pass

MIMO

802.11n20 LOW CHANNEL

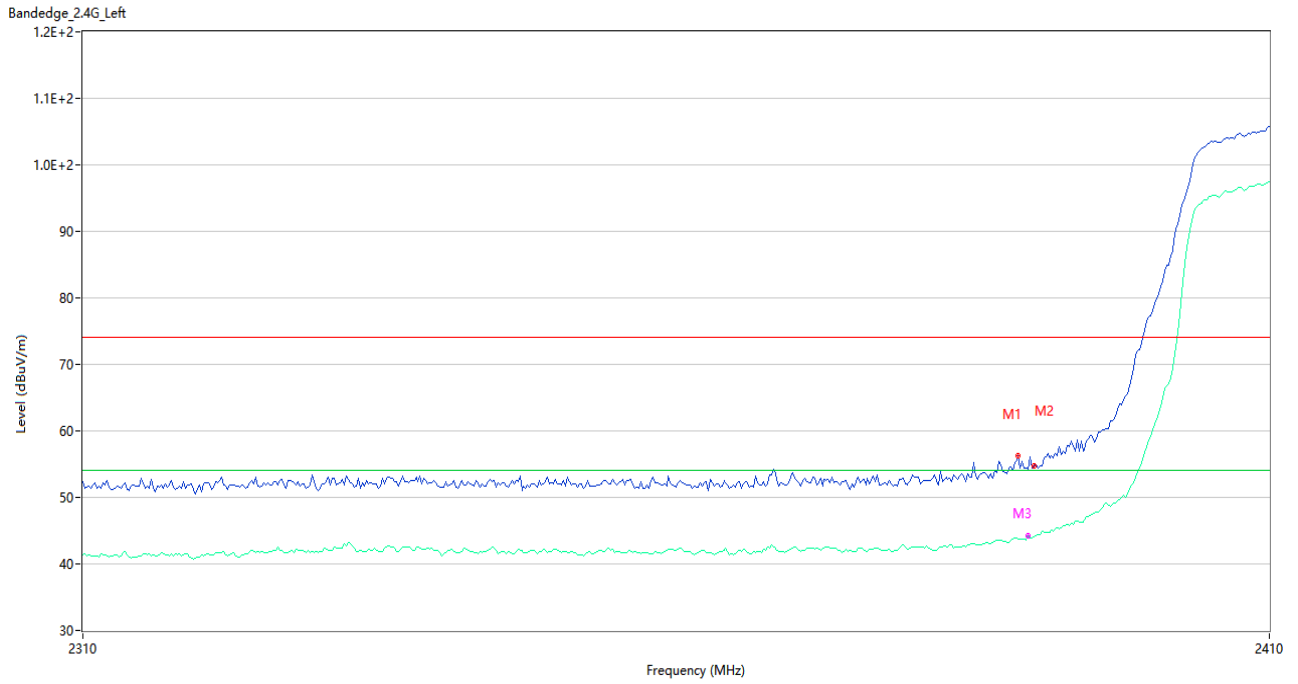

No.	Frequency (MHz)	Results (dBuV/m)	Factor (dB)	Limit (dBuV/m)	Margin (dB)	Detector	Table (Degree)	Height (cm)	Antenna	Verdict
1	2388.500	56.32	-3.02	74.0	17.68	Peak	45.00	150	Horizontal	Pass
1**	2388.500	43.79	-3.02	54.0	10.21	AV	45.00	150	Horizontal	Pass
2	2389.833	54.75	-3.45	74.0	19.25	Peak	51.00	150	Horizontal	Pass
2**	2389.833	44.04	-3.45	54.0	9.96	AV	51.00	150	Horizontal	Pass
3	2389.333	54.19	-3.45	74.0	19.81	Peak	177.00	200	Horizontal	Pass
3**	2389.333	44.22	-3.45	54.0	9.78	AV	177.00	200	Horizontal	Pass

802.11n20 HIGH CHANNEL

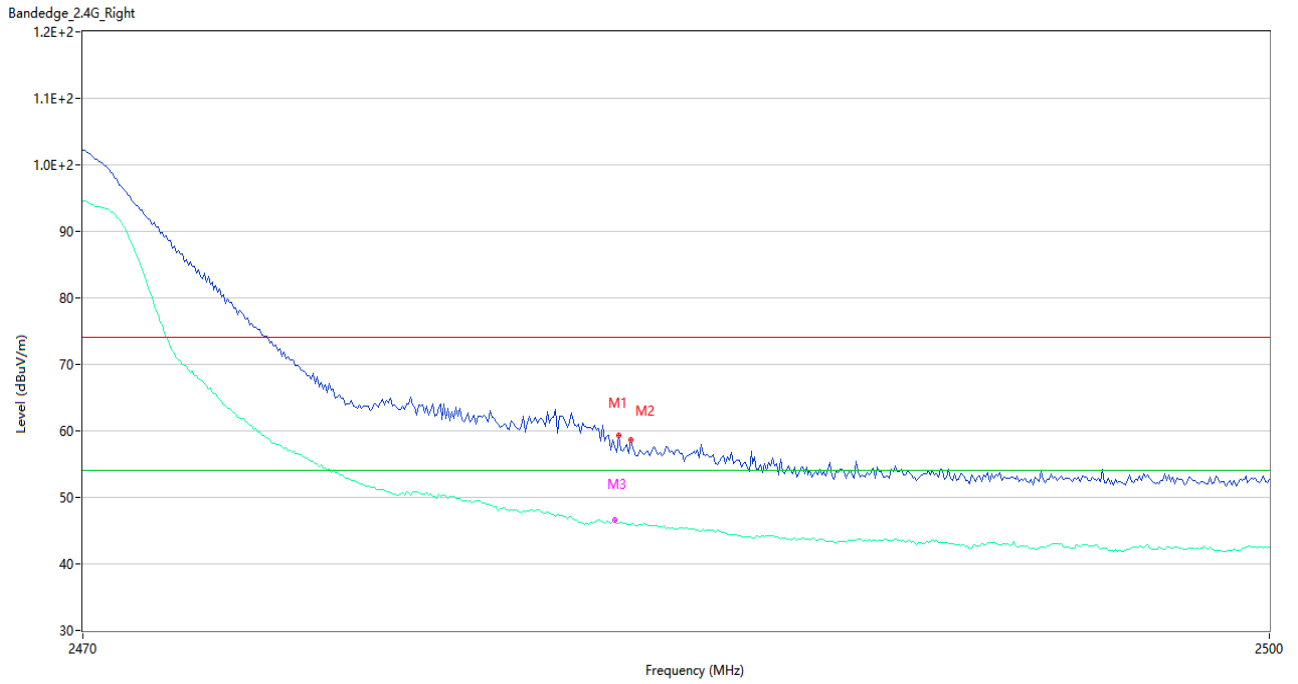

No.	Frequency (MHz)	Results (dBuV/m)	Factor (dB)	Limit (dBuV/m)	Margin (dB)	Detector	Table (Degree)	Height (cm)	Antenna	Verdict
1	2483.500	59.26	-2.54	74.0	14.74	Peak	182.00	100	Horizontal	Pass
1**	2483.500	46.15	-2.54	54.0	7.85	AV	182.00	100	Horizontal	Pass
2	2483.800	58.66	-2.68	74.0	15.34	Peak	190.00	150	Horizontal	Pass
2**	2483.800	45.90	-2.68	54.0	8.10	AV	190.00	150	Horizontal	Pass
3	2483.400	57.70	-2.54	74.0	16.30	Peak	15.00	200	Horizontal	Pass
3**	2483.400	46.53	-2.54	54.0	7.47	AV	15.00	200	Horizontal	Pass

802.11n40 LOW CHANNEL

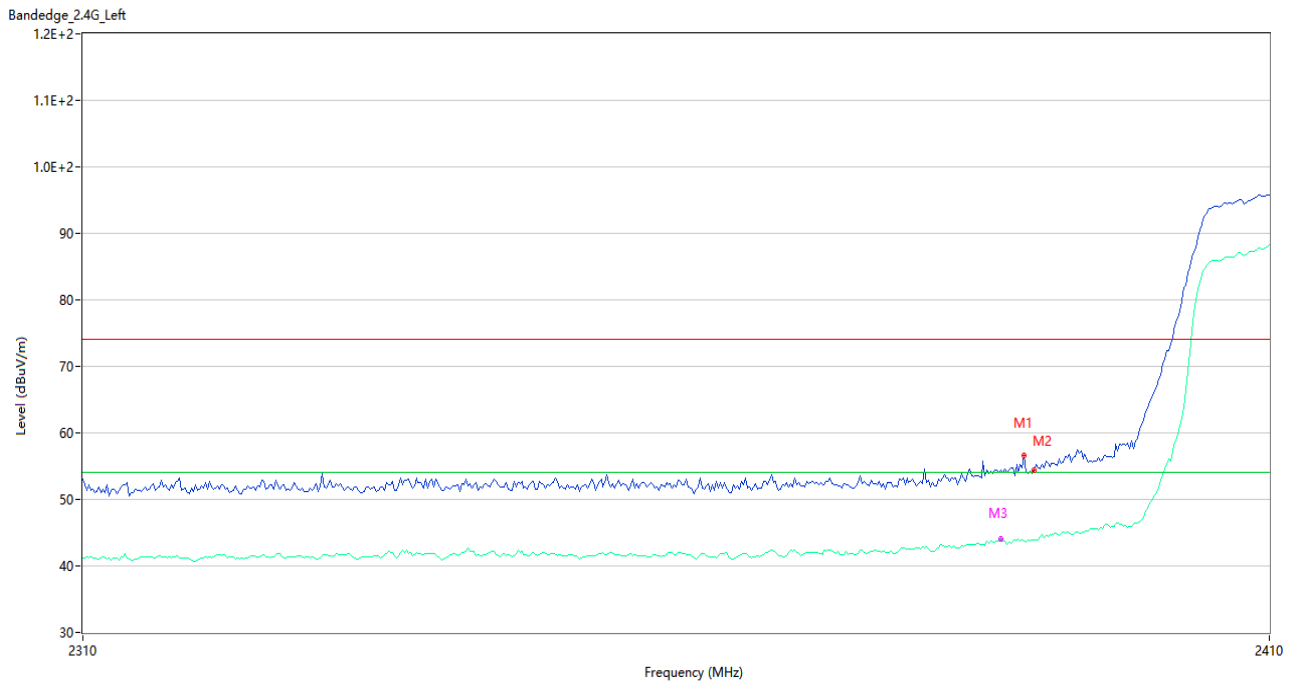

No.	Frequency (MHz)	Results (dBuV/m)	Factor (dB)	Limit (dBuV/m)	Margin (dB)	Detector	Table (Degree)	Height (cm)	Antenna	Verdict
1	2389.000	56.57	-3.43	74.0	17.43	Peak	49.00	150	Horizontal	Pass
1**	2389.000	43.73	-3.43	54.0	10.27	AV	49.00	150	Horizontal	Pass
2	2389.833	54.49	-3.45	74.0	19.51	Peak	331.00	100	Horizontal	Pass
2**	2389.833	43.89	-3.45	54.0	10.11	AV	331.00	100	Horizontal	Pass
3	2387.000	54.38	-2.66	74.0	19.62	Peak	62.00	200	Horizontal	Pass
3**	2387.000	44.08	-2.66	54.0	9.92	AV	62.00	200	Horizontal	Pass

802.11n40 HIGH CHANNEL

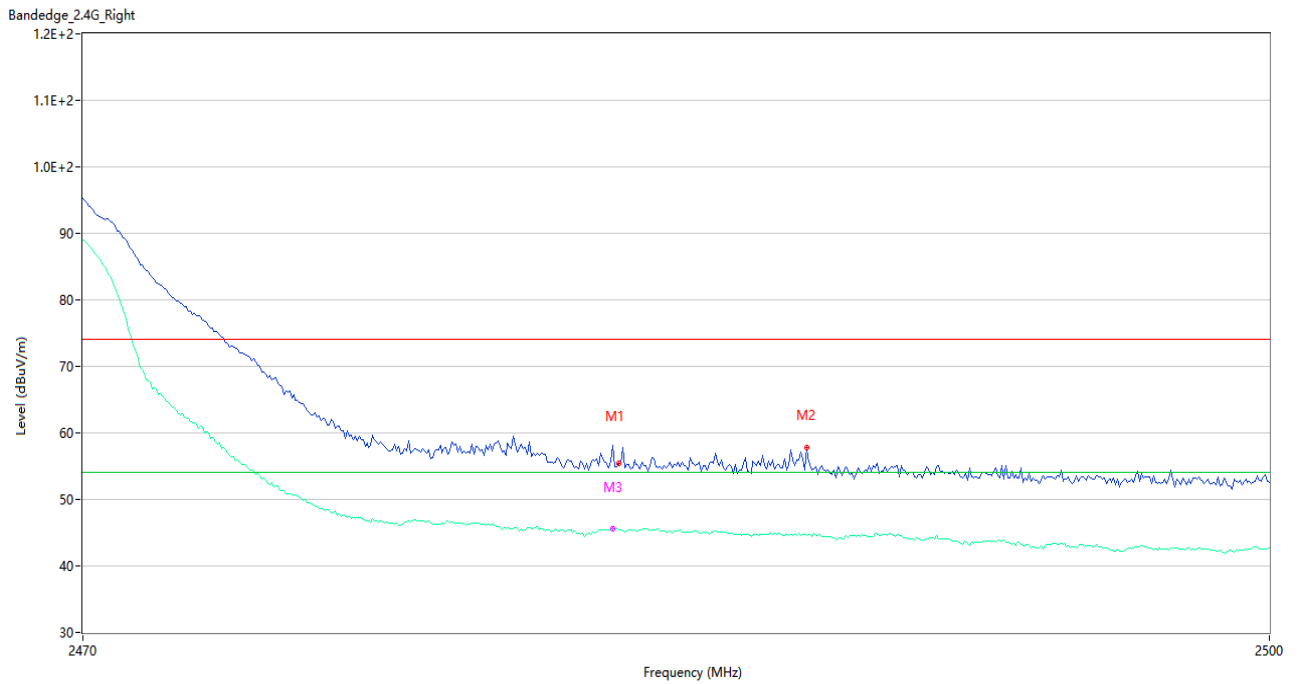

No.	Frequency (MHz)	Results (dBuV/m)	Factor (dB)	Limit (dBuV/m)	Margin (dB)	Detector	Table (Degree)	Height (cm)	Antenna	Verdict
1	2483.500	55.45	-2.54	74.0	18.55	Peak	180.00	200	Horizontal	Pass
1**	2483.500	45.48	-2.54	54.0	8.52	AV	180.00	200	Horizontal	Pass
2	2488.250	57.78	-2.63	74.0	16.22	Peak	180.00	100	Horizontal	Pass
2**	2488.250	44.65	-2.63	54.0	9.35	AV	180.00	100	Horizontal	Pass
3	2483.350	58.05	-2.54	74.0	15.95	Peak	182.00	150	Horizontal	Pass
3**	2483.350	45.65	-2.54	54.0	8.35	AV	182.00	150	Horizontal	Pass

A.8 Power Spectral Density (PSD)

Note: The Power Spectral Density (PSD) please refer to report: BL-EC19A0003-603, which was issued by Shenzhen BALUN Technology Co., Ltd. on Dec. 12, 2019, **section A.8 Power Spectral Density (PSD)**.

ANNEX B TEST SETUP PHOTOS

Please refer the document “BL-EC22B1059-AR.PDF”.

ANNEX C EUT EXTERNAL PHOTOS

Please refer the document “BL-EC22B1059-AW.PDF”.

ANNEX D EUT INTERNAL PHOTOS

Please refer the document “BL-EC22B1059-AI.PDF”.

Statement

1. The laboratory guarantees the scientificity, accuracy and impartiality of the test, and is responsible for all the information in the report, except the information provided by the customer. The customer is responsible for the impact of the information provided on the validity of the results.
2. The report without China inspection body and laboratory Mandatory Approval (CMA) mark has no effect of proving to the society.
3. For the report with CNAS mark or A2LA mark, the items marked with "☆" are not within the accredited scope.
4. This report is invalid if it is altered, without the signature of the testing and approval personnel, or without the "inspection and testing dedicated stamp" or test report stamp.
5. The test data and results are only valid for the tested samples provided by the customer.
6. This report shall not be partially reproduced without the written permission of the laboratory.
7. Any objection shall be raised to the laboratory within 30 days after receiving the report.

--END OF REPORT--