

4.3.2 Test Procedure

Test method Refer as KDB 789033 D02, Section E.3.b.

1. The EUT RF output connected to the power meter by RF cable.
2. Setting maximum power transmit of EUT.
3. The path loss was compensated to the results for each measurement.
4. Measure and record the result of Average output power. in the test report.

4.3.3 Test Setup

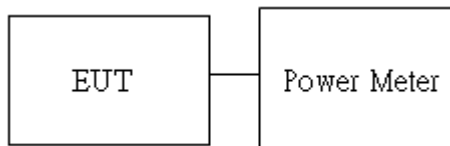

Report No.: T190315W01-RP4

4.3.4 Test Result

Conducted output power :

UNII-1						
Config	CH	Freq. (MHz)	Power Set	AV Power (dBm)	AV Power (W)	Limit (dBm)
IEEE 802.11a Data rate: 6Mbps	36	5180	63	15.51	0.0356	24
	44	5220	63	15.60	0.0363	
	48	5240	63	15.92	0.0391	
IEEE 802.11n HT20 Data rate: MCS0	36	5180	63	15.28	0.0337	
	44	5220	63	15.15	0.0327	
	48	5240	63	15.55	0.0359	
IEEE 802.11n HT40 Data rate: MCS0	38	5190	63	16.81	0.0480	
	46	5230	63	16.73	0.0471	
IEEE 802.11ac VHT80 Data rate: MCS0	42	5210	63	16.77	0.0475	

UNII-2a						
Config	CH	Freq. (MHz)	Power Set	AV Power (dBm)	AV Power (W)	Limit (dBm)
IEEE 802.11a Data rate: 6Mbps	52	5260	63	16.28	0.0425	24
	56	5280	63	16.54	0.0451	
	64	5320	63	16.15	0.0412	
IEEE 802.11n HT20 Data rate: MCS0	52	5260	63	15.96	0.0394	
	56	5280	63	16.22	0.0419	
	64	5320	63	16.34	0.0431	
IEEE 802.11n HT40 Data rate: MCS0	54	5270	63	17.43	0.0553	
	62	5310	63	17.40	0.0550	
IEEE 802.11ac VHT80 Data rate: MCS0	58	5290	63	16.88	0.0488	



Report No.: T190315W01-RP4

Page: 54 / 192
Rev.: 01

UNII-2c						
Config	CH	Freq. (MHz)	Power Set	AV Power (dBm)	AV Power (W)	Limit (dBm)
IEEE 802.11a Data rate: 6Mbps	100	5500	63	17.15	0.0519	24
	116	5580	63	17.93	0.0621	
	140	5700	63	17.44	0.0555	
IEEE 802.11n HT20 Data rate: MCS0	100	5500	63	17.16	0.0520	
	116	5580	63	17.73	0.0593	
	140	5700	63	17.88	0.0614	
IEEE 802.11n HT40 Data rate: MCS0	102	5510	63	17.17	0.0521	
	110	5550	63	18.13	0.0650	
	134	5670	63	18.46	0.0701	
IEEE 802.11ac VHT80 Data rate: MCS0	106	5530	63	17.45	0.0556	



Report No.: T190315W01-RP4

Page: 55 / 192
Rev.: 01

UNII-3						
Config	CH	Freq. (MHz)	Power Set	AV Power (dBm)	AV Power (W)	Limit (dBm)
IEEE 802.11a Data rate: 6Mbps	149	5745	63	17.68	0.0531	30
	157	5785	63	17.38	0.0541	
	165	5825	63	17.64	0.0568	
IEEE 802.11n HT20 Data rate: MCS0	149	5745	63	17.85	0.0565	
	157	5785	63	18.31	0.0813	
	165	5825	63	18.22	0.0759	
IEEE 802.11n HT40 Data rate:	151	5755	63	18.25	0.0705	
	159	5795	63	18.64	0.0726	
IEEE 802.11ac VHT80	155	5775	63	18.51	0.0551	



Report No.: T190315W01-RP4

4.4 POWER SPECTRAL DENSITY

4.4.1 Test Limit

According to §15.407 (a)(1), 15.407(a)(2) and 15.407(a)(3),

UNII-1 :

FCC: The maximum power spectral density shall not exceed 11 dBm in any 1 megahertz band.

UNII-2a and 2c:

The maximum power spectral density shall not exceed 11 dBm in any 1 megahertz band.

If transmitting antennas of directional gain greater than 6 dBi are used, both the maximum conducted output power and the maximum power spectral density shall be reduced by the amount in dB that the directional gain of the antenna exceeds 6 dBi.

UNII-3:

For the band 5.725-5.85 GHz, the maximum conducted output power over the frequency band of operation shall not exceed 1 W. In addition, the maximum power spectral density shall not exceed 30 dBm in any 500-kHz band. If transmitting antennas of directional gain greater than 6 dBi are used, both the maximum conducted output power and the maximum power spectral density shall be reduced by the amount in dB that the directional gain of the antenna exceeds 6 dBi.

UNII-1 Limit	<input checked="" type="checkbox"/> Antenna not exceed 6 dBi : 11 dBm <input type="checkbox"/> Antenna with DG greater than 6 dBi : [Limit = 11 – (DG – 6)]
UNII-2a Limit	<input checked="" type="checkbox"/> Antenna not exceed 6 dBi : 11 dBm <input type="checkbox"/> Antenna with DG greater than 6 dBi : [Limit = 11 – (DG – 6)]
UNII-2c Limit	<input checked="" type="checkbox"/> Antenna not exceed 6 dBi : 11 dBm <input type="checkbox"/> Antenna with DG greater than 6 dBi : [Limit = 11 – (DG – 6)]
UNII-3 Limit	<input checked="" type="checkbox"/> Antenna not exceed 6 dBi : 30 dBm <input type="checkbox"/> Antenna with DG greater than 6 dBi : [Limit = 30 – (DG – 6)]

Report No.: T190315W01-RP4

4.4.2 Test Procedure

Test method Refer as KDB 789033 D02

1. The EUT RF output connected to the spectrum analyzer by RF cable.
2. Setting maximum power transmit of EUT
3. UNII-1, UNII-2a and UNII-2c, SA set RBW = 1MHz, VBW = 3MHz and Detector = RMS, to measurement Power Density.
4. UNII-3, SA set RBW = 500kHz, VBW = 2MHz and Detector = RMS, to measurement Power Density
5. The path loss and Duty Factor were compensated to the results for each measurement by SA.
6. Mark the maximum level.
7. Measure and record the result of power spectral density. in the test report.

4.4.3 Test Setup

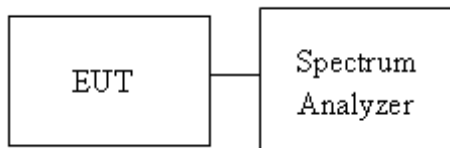

Report No.: T190315W01-RP4

4.4.4 Test Result

UNII-1 5150-5250 MHz			
Test mode: IEEE 802.11a mode			
Channel	Frequency (MHz)	PPSD (dBm)	Limit (dBm)
Low	5180	3.45	11
Mid	5220	3.11	
High	5240	3.22	
Test mode: IEEE 802.11n HT20 mode			
Channel	Frequency (MHz)	PPSD (dBm)	Limit (dBm)
Low	5180	3.02	11
Mid	5220	2.63	
High	5240	2.76	
Test mode: IEEE 802.11n HT40 mode			
Channel	Frequency (MHz)	PPSD (dBm)	Limit (dBm)
Low	5190	0.06	11
High	5230	-0.19	
Test mode: IEEE 802.11ac VHT80 mode			
Channel	Frequency (MHz)	PPSD (dBm)	Limit (dBm)
Mid	5210	-2.15	11

UNII-2a 5250-5350 MHz			
Test mode: IEEE 802.11a mode			
Channel	Frequency (MHz)	PPSD (dBm)	Limit (dBm)
Low	5260	3.33	11
Mid	5280	3.13	
High	5320	2.62	
Test mode: IEEE 802.11n HT20 mode			
Channel	Frequency (MHz)	PPSD (dBm)	Limit (dBm)
Low	5260	2.95	11
Mid	5280	2.88	
High	5320	3.08	
Test mode: IEEE 802.11n HT40 mode			
Channel	Frequency (MHz)	PPSD (dBm)	Limit (dBm)
Low	5270	-0.2	11
High	5310	-0.5	
Test mode: IEEE 802.11ac VHT80 mode			
Channel	Frequency (MHz)	PPSD (dBm)	Limit (dBm)
Mid	5290	-2.2	11



Report No.: T190315W01-RP4

Page: 60 / 192
Rev.: 01

UNII-2c 5470-5725 MHz			
Test mode: IEEE 802.11a mode			
Channel	Frequency (MHz)	PPSD (dBm)	Limit (dBm)
Low	5500	3.58	11
Mid	5580	4.63	
High	5700	5.5	
Test mode: IEEE 802.11n HT20 mode			
Channel	Frequency (MHz)	PPSD (dBm)	Limit (dBm)
Low	5500	3.78	11
Mid	5580	4.78	
High	5700	5.36	
Test mode: IEEE 802.11n HT40 mode			
Channel	Frequency (MHz)	PPSD (dBm)	Limit (dBm)
Low	5510	0.51	11
Mid	5550	1.98	
High	5670	2.51	
Test mode: IEEE 802.11ac VHT80 mode			
Channel	Frequency (MHz)	PPSD (dBm)	Limit (dBm)
Mid	5530	-0.72	11



Report No.: T190315W01-RP4

Page: 61 / 192
Rev.: 01

UNII-3 5725-5825 MHz			
Test mode: IEEE 802.11a mode			
Channel	Frequency (MHz)	PPSD (dBm)	Limit (dBm)
Low	5745	9.19	30
Mid	5785	8.87	
High	5825	8.25	
Test mode: IEEE 802.11n 20 MHz mode			
Channel	Frequency (MHz)	PPSD (dBm)	Limit (dBm)
Low	5745	9.57	30
Mid	5785	9.24	
High	5825	8.65	
Test mode: IEEE 802.11n 40 MHz mode			
Channel	Frequency (MHz)	PPSD (dBm)	Limit (dBm)
Low	5755	7.48	30
High	5795	7.17	
Test mode: IEEE 802.11ac VHT80 mode			
Channel	Frequency (MHz)	PPSD (dBm)	Limit (dBm)
Mid	5775	3.96	30



Report No.: T190315W01-RP4

Test Data

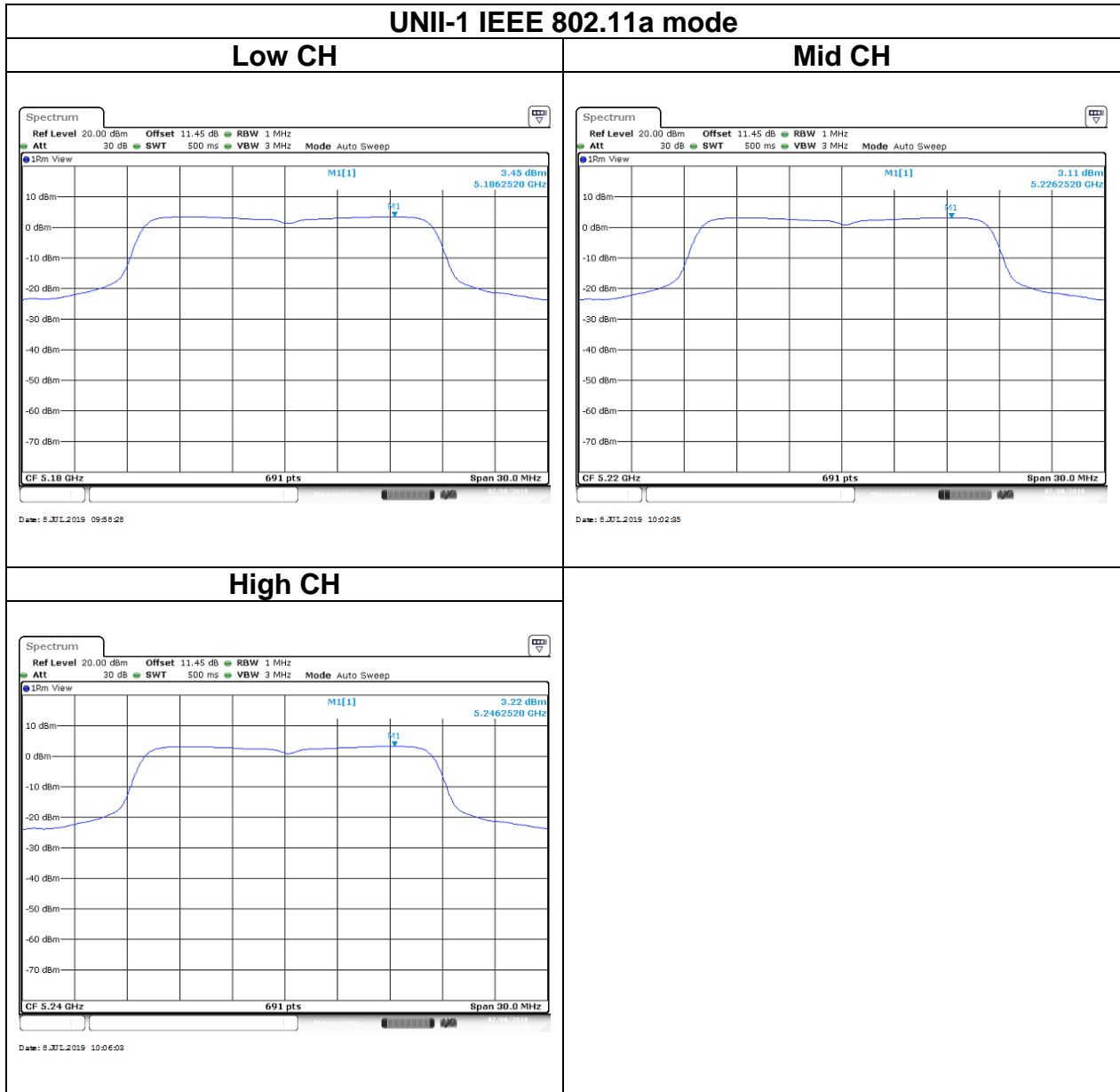



Report No.: T190315W01-RP4

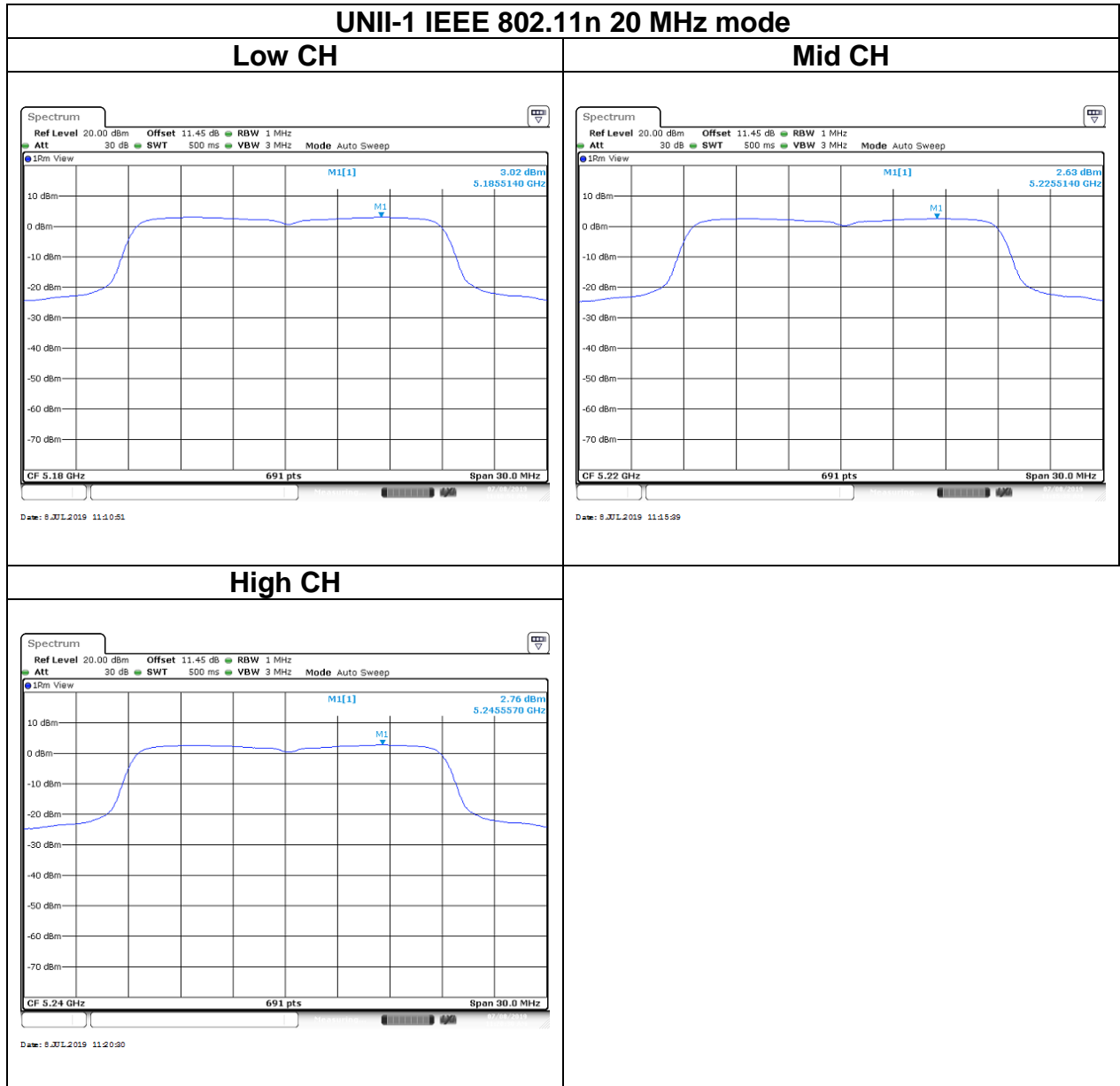



Report No.: T190315W01-RP4

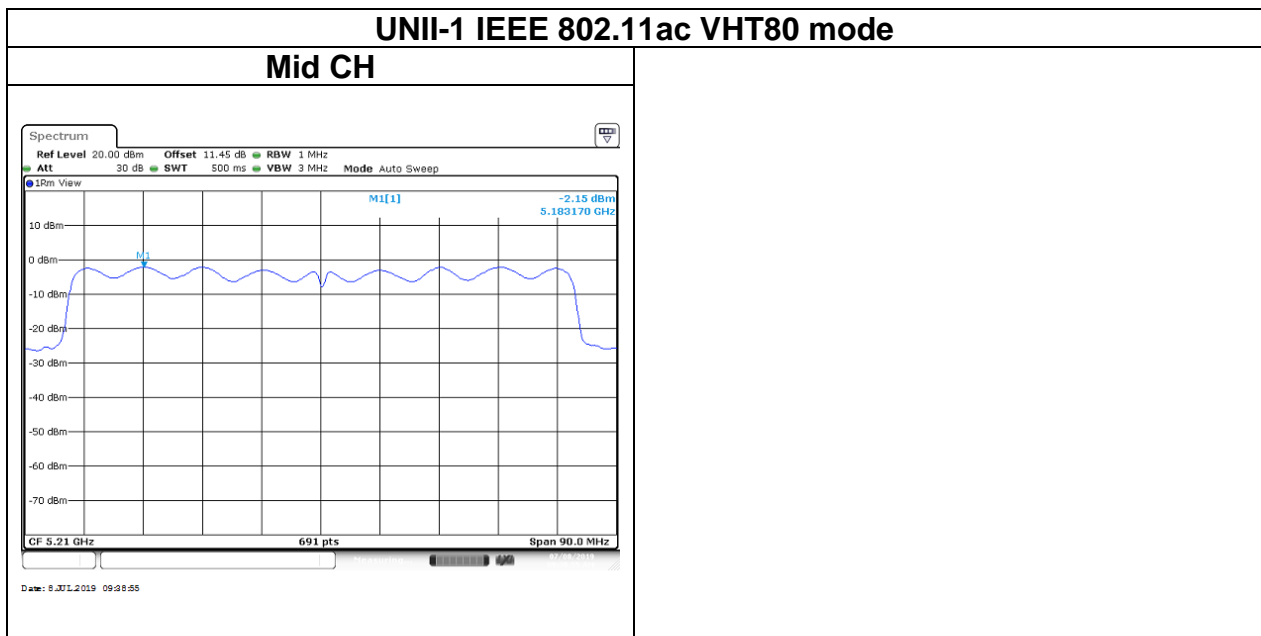
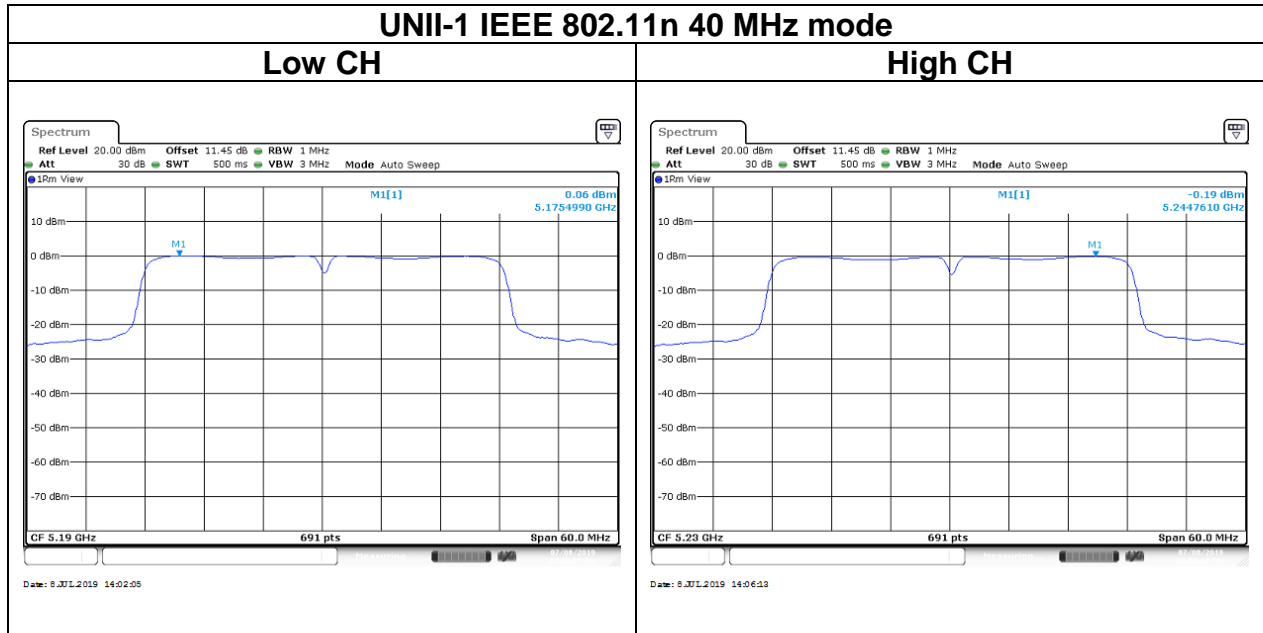



Report No.: T190315W01-RP4

Test Data

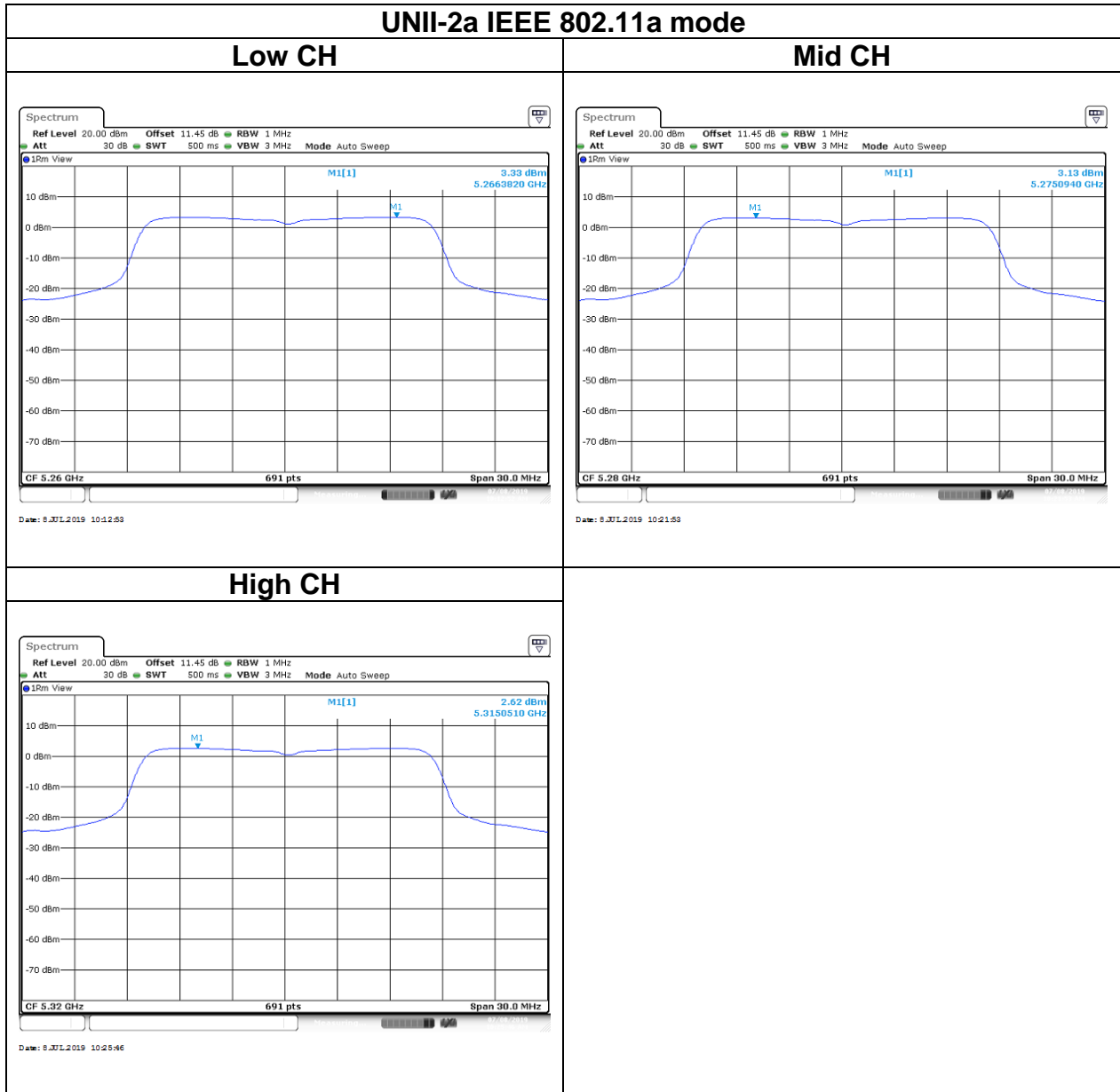



Report No.: T190315W01-RP4

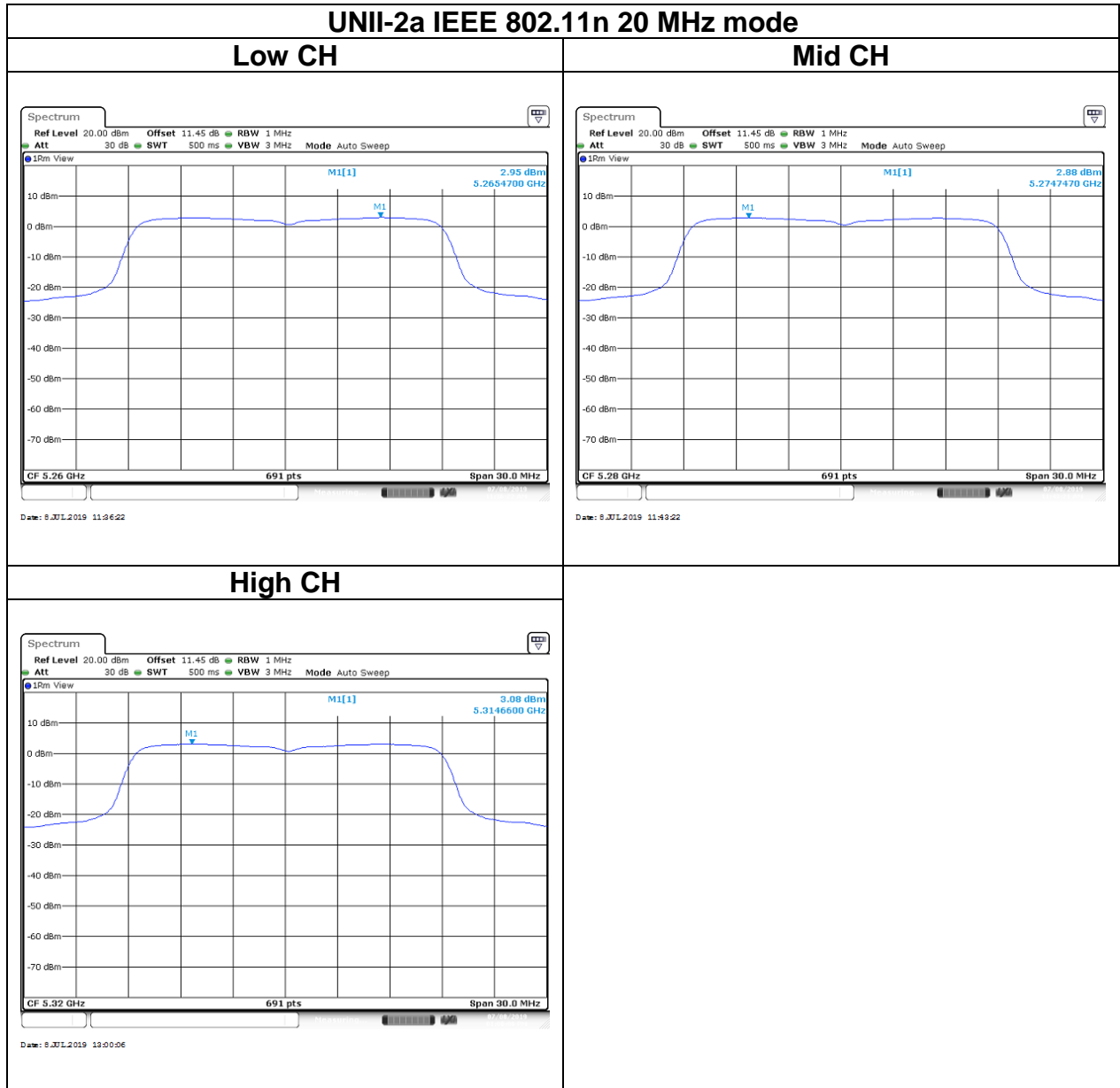



Report No.: T190315W01-RP4

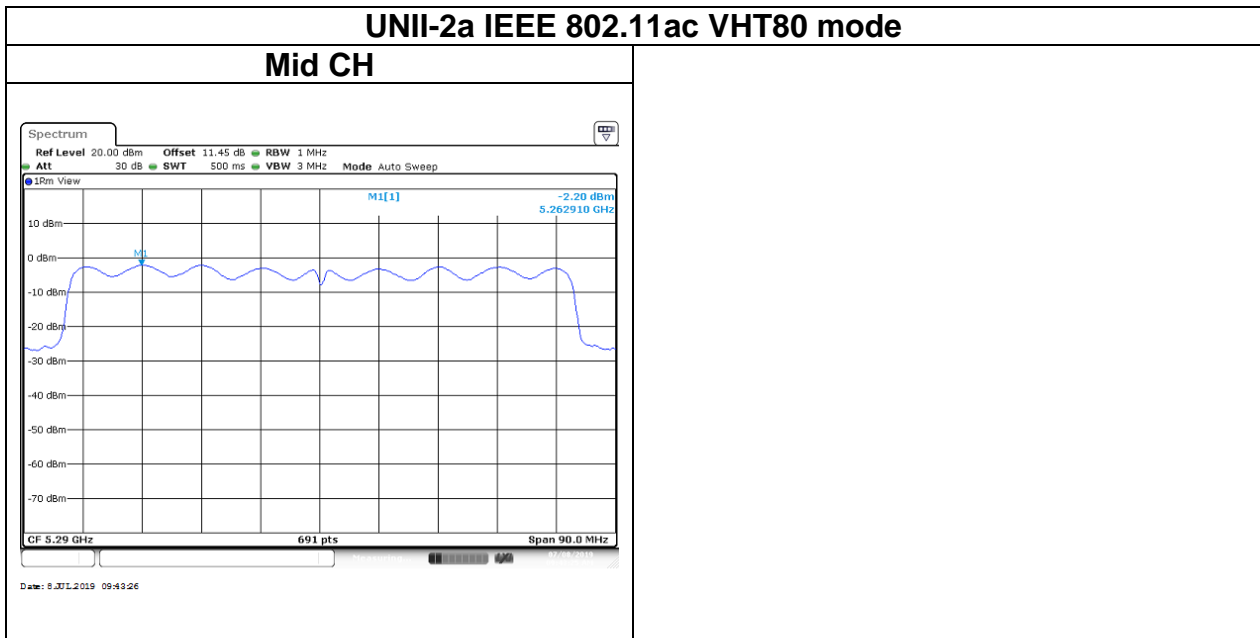
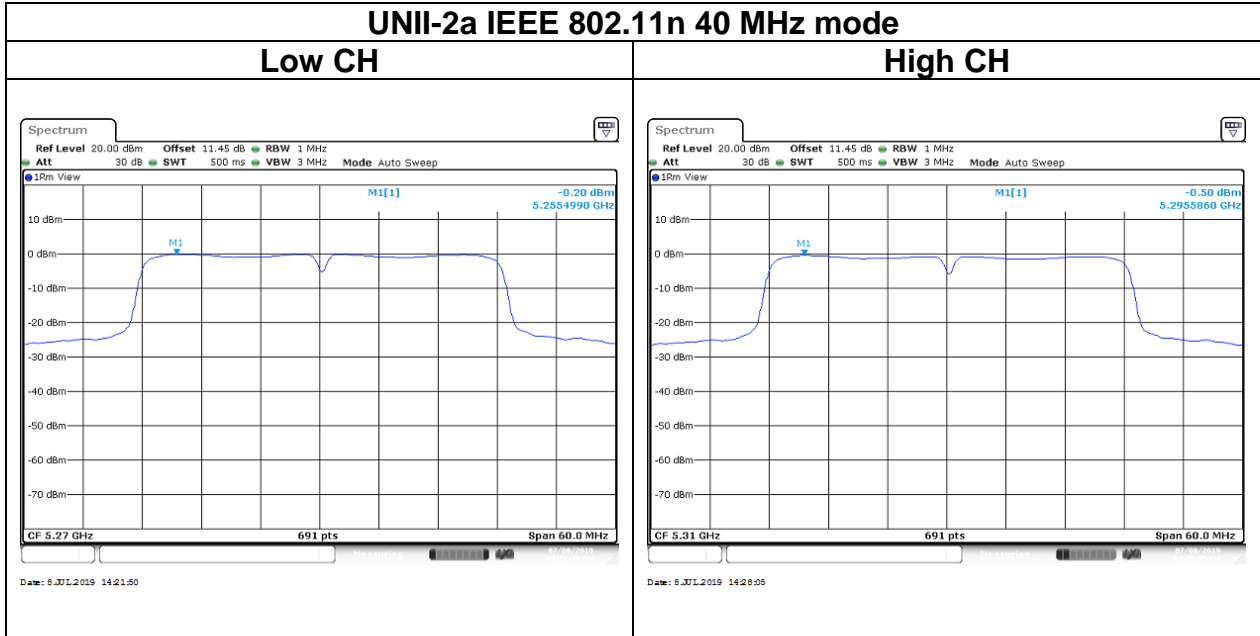

Report No.: T190315W01-RP4

Test Data

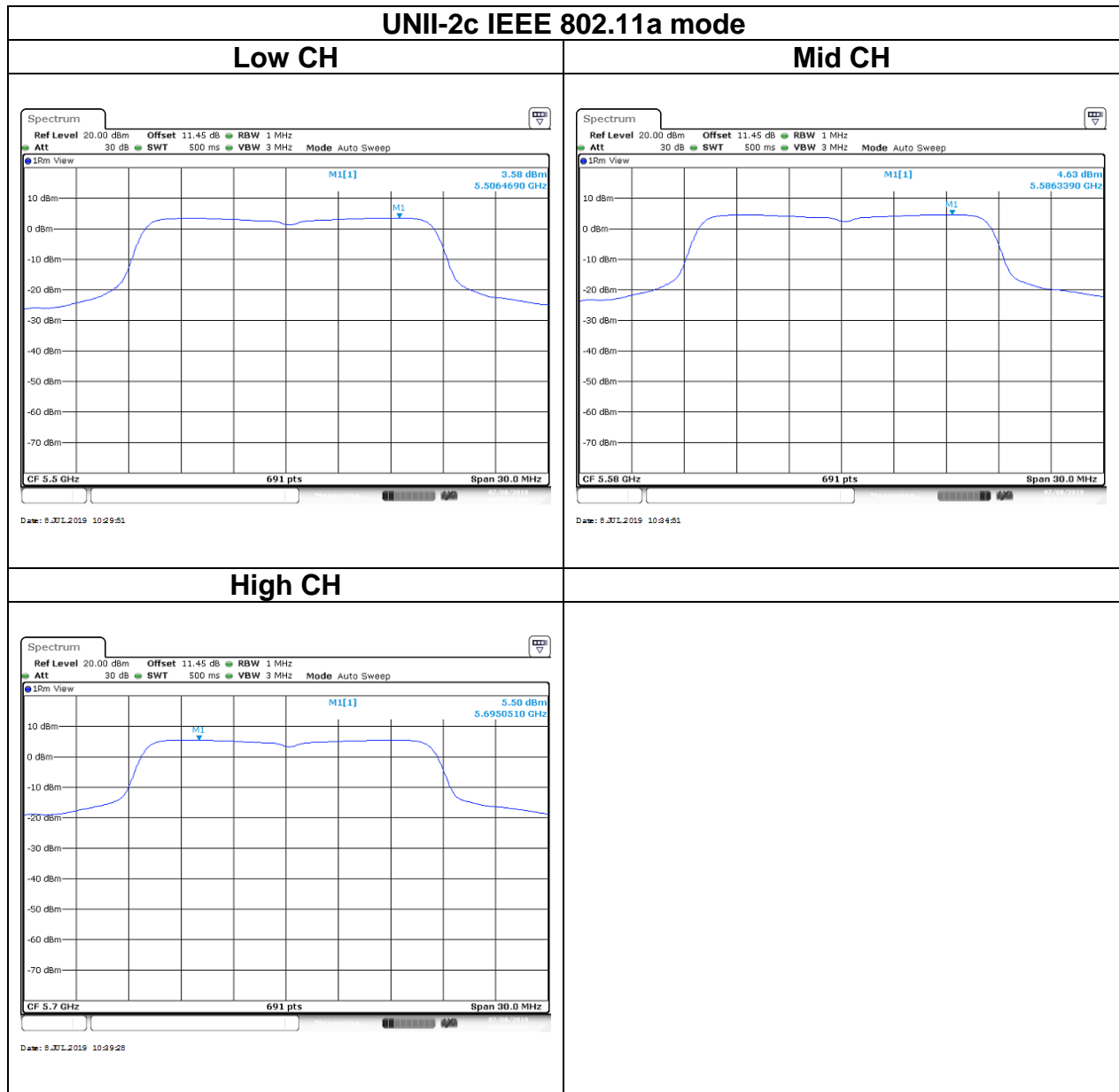



Report No.: T190315W01-RP4

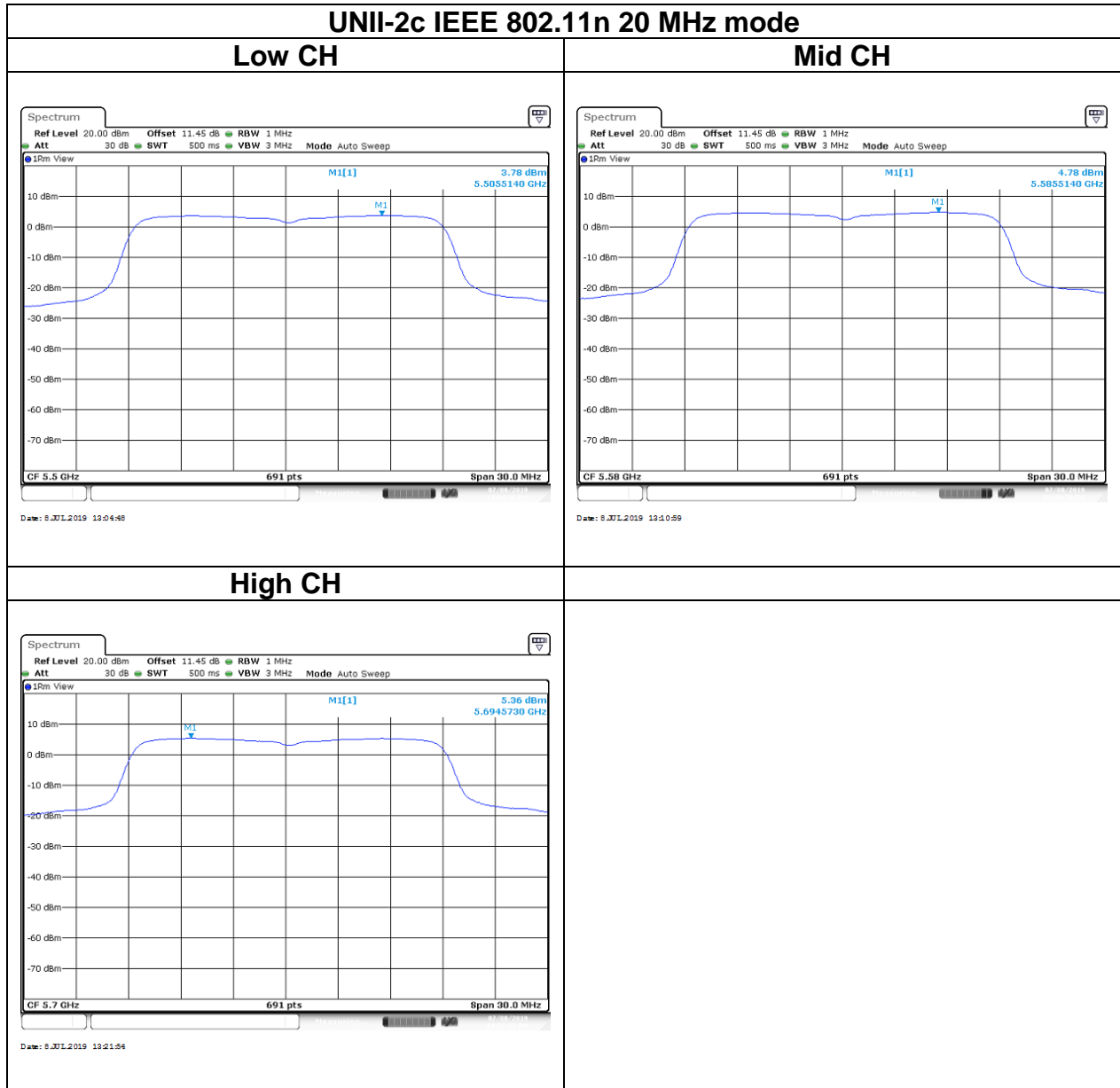



Report No.: T190315W01-RP4

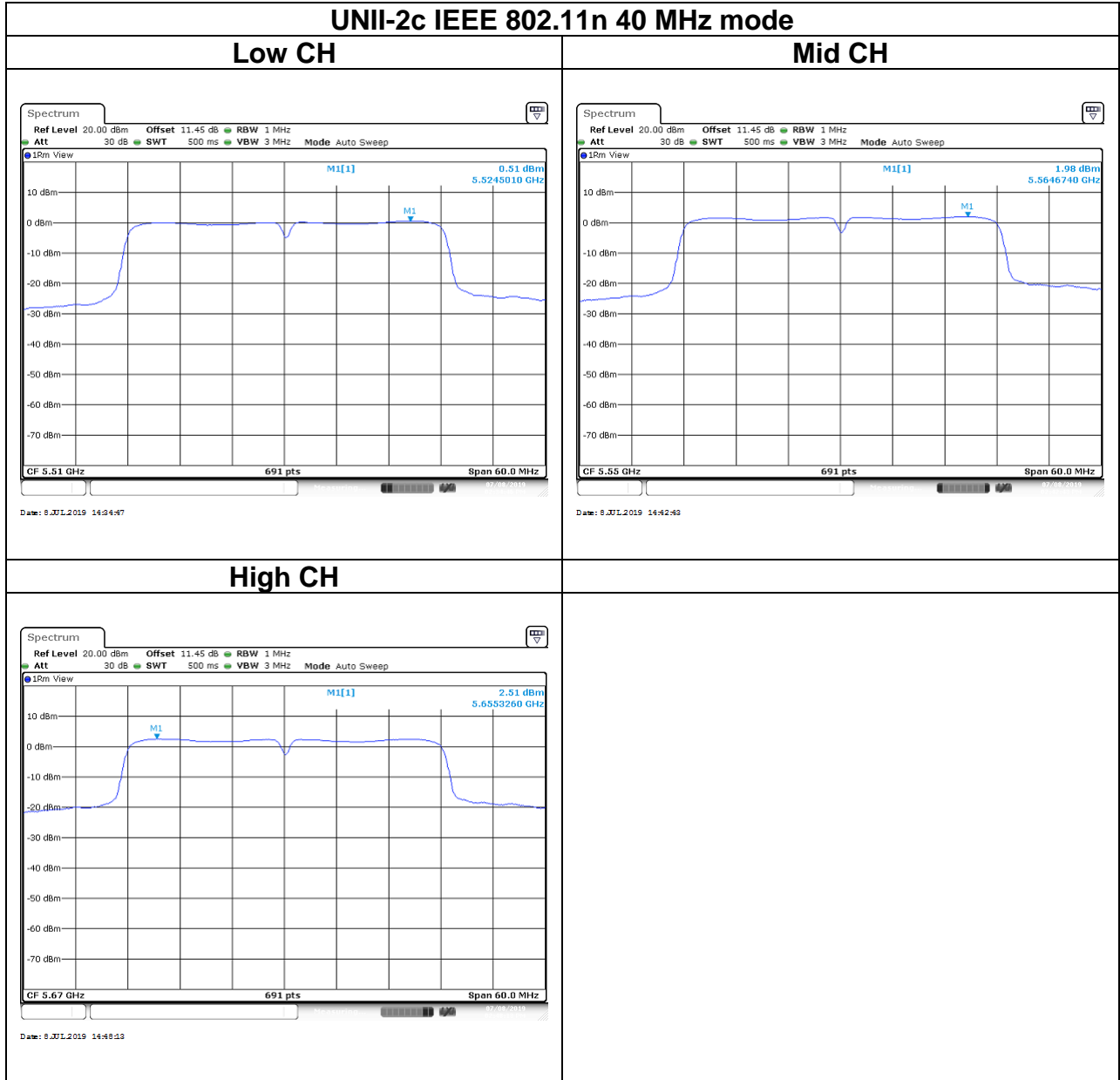



Report No.: T190315W01-RP4

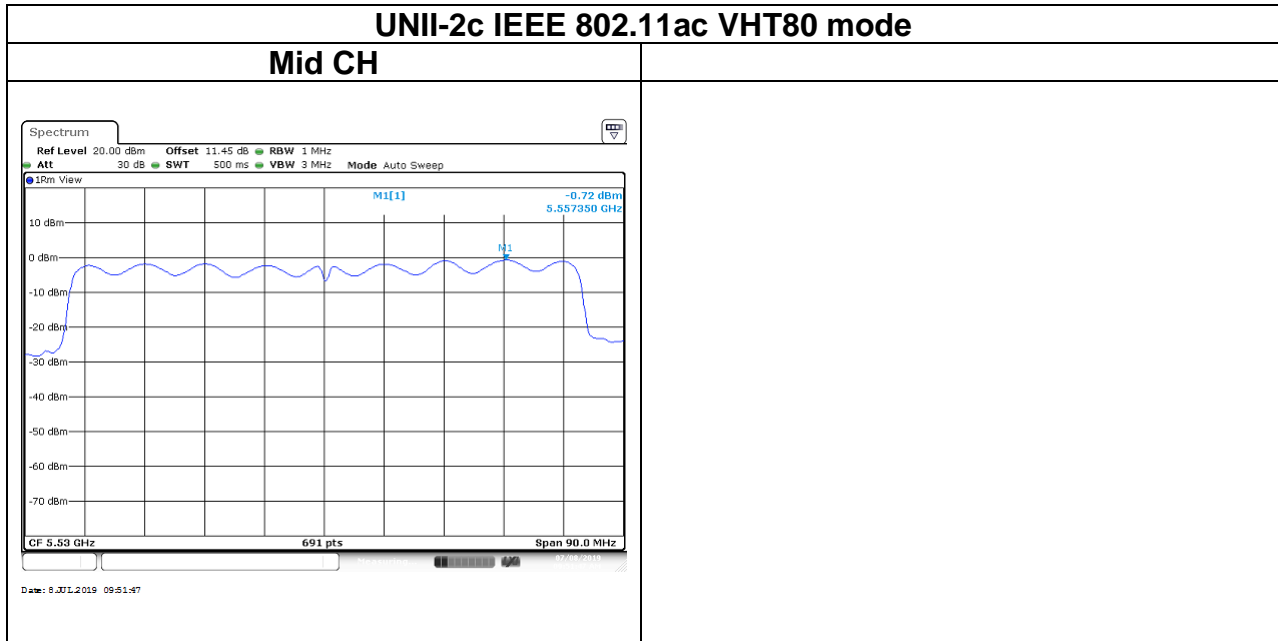



Report No.: T190315W01-RP4

Test Data

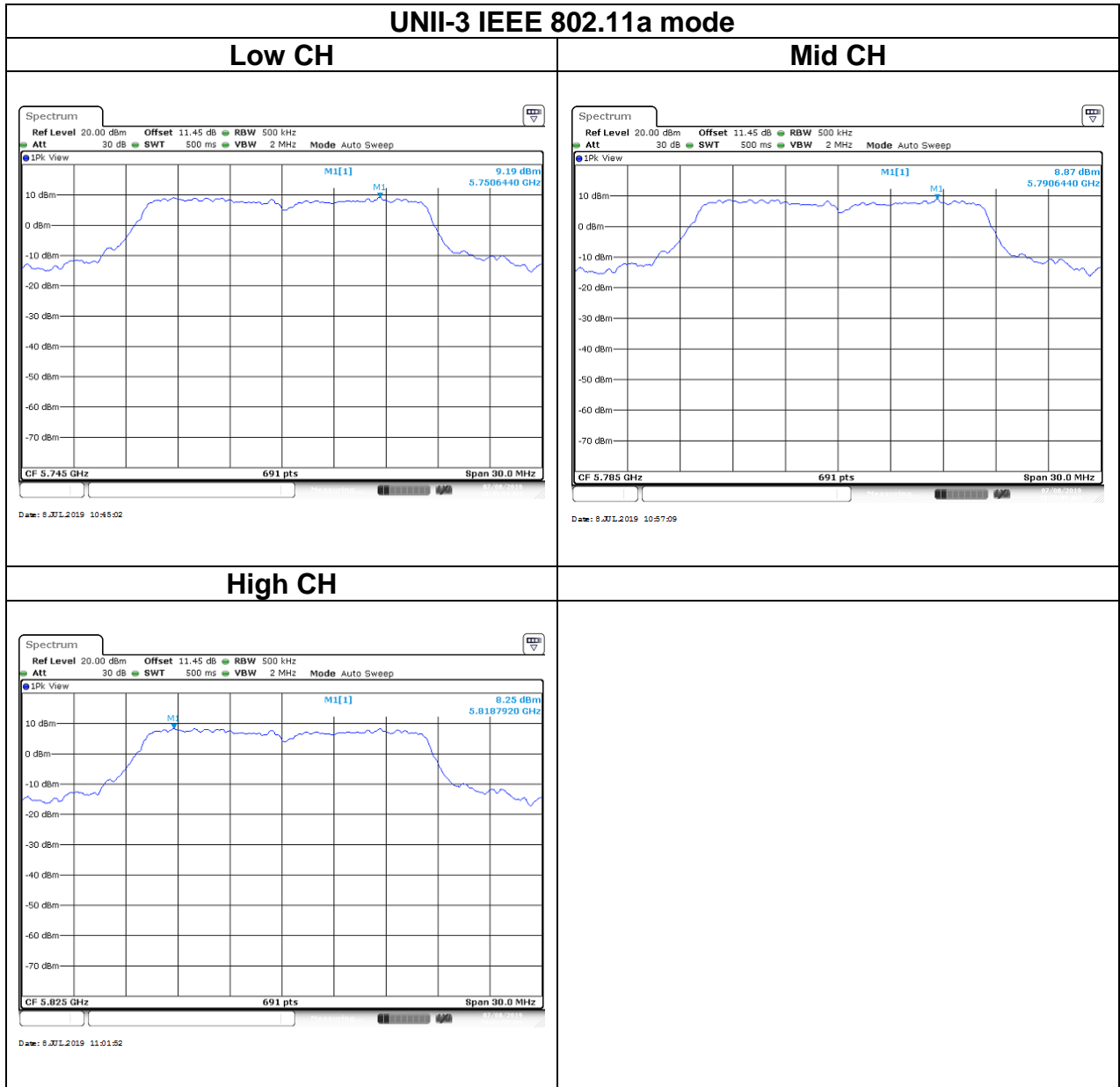



Report No.: T190315W01-RP4

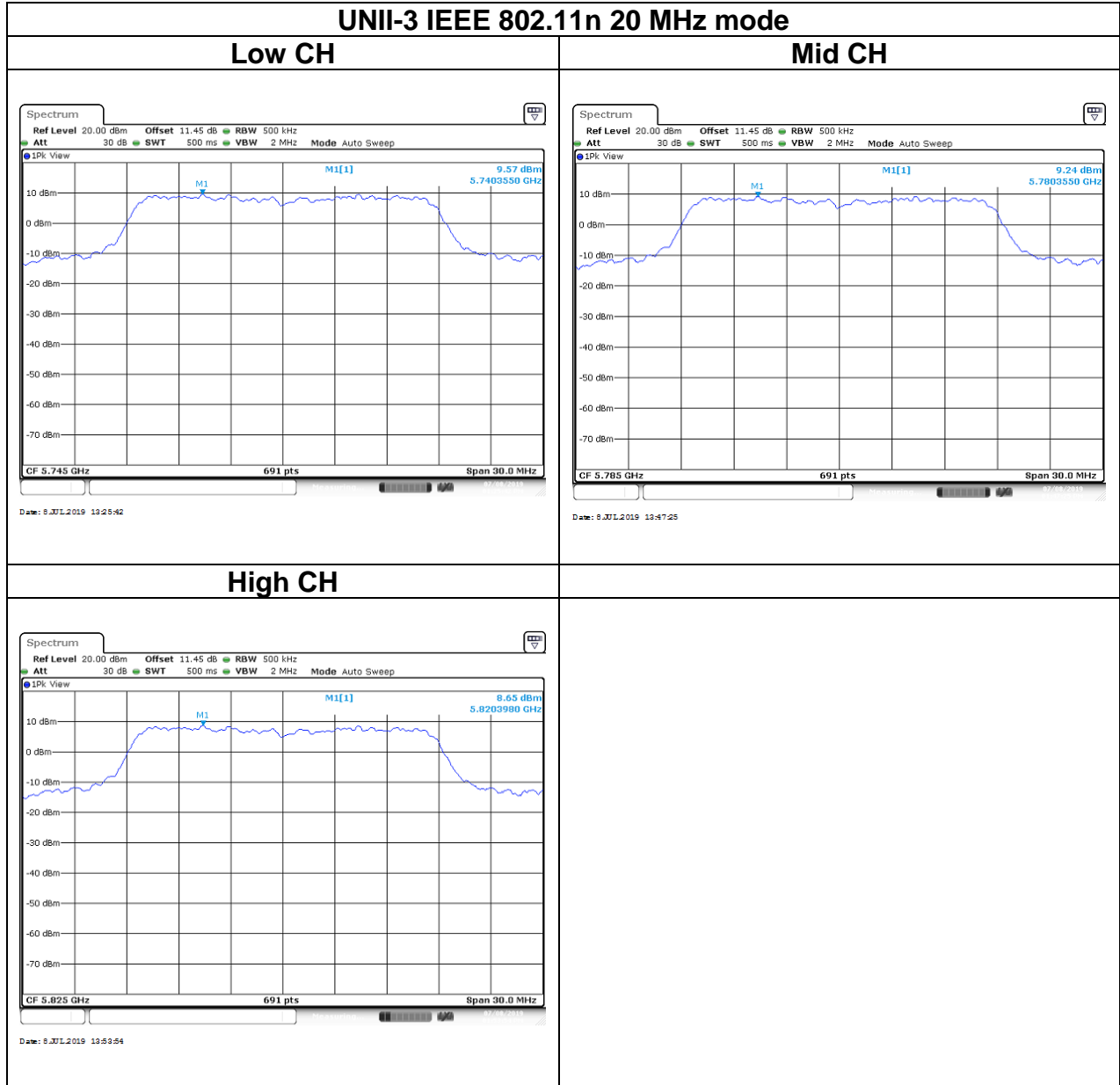



Report No.: T190315W01-RP4

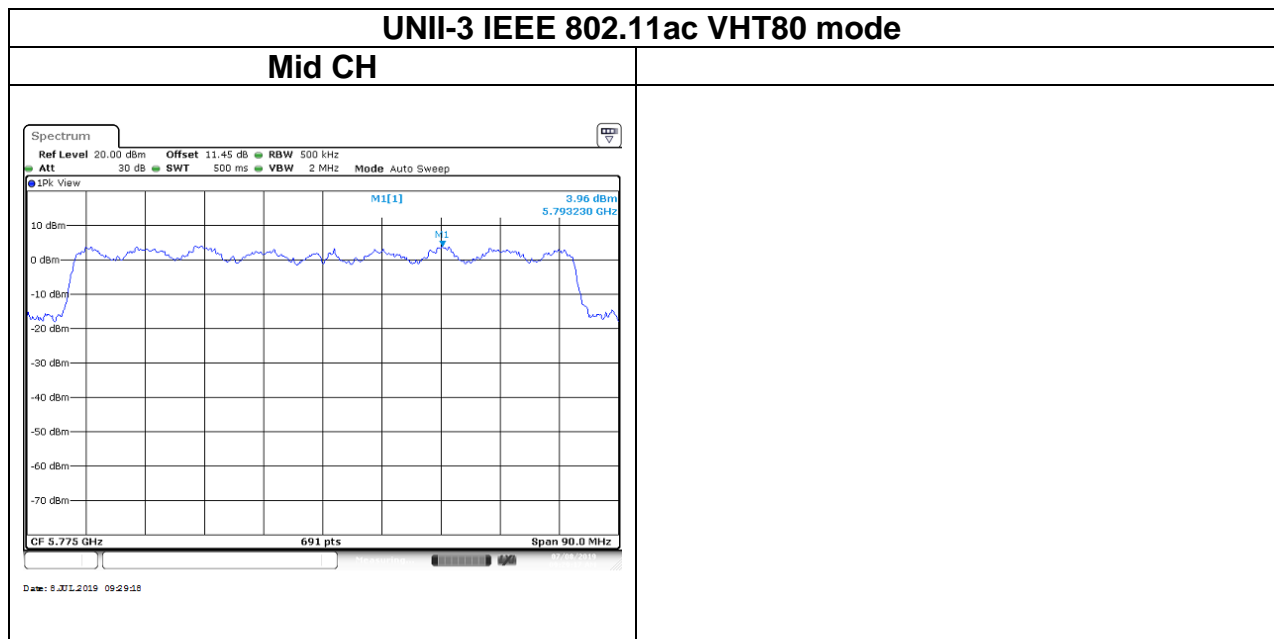
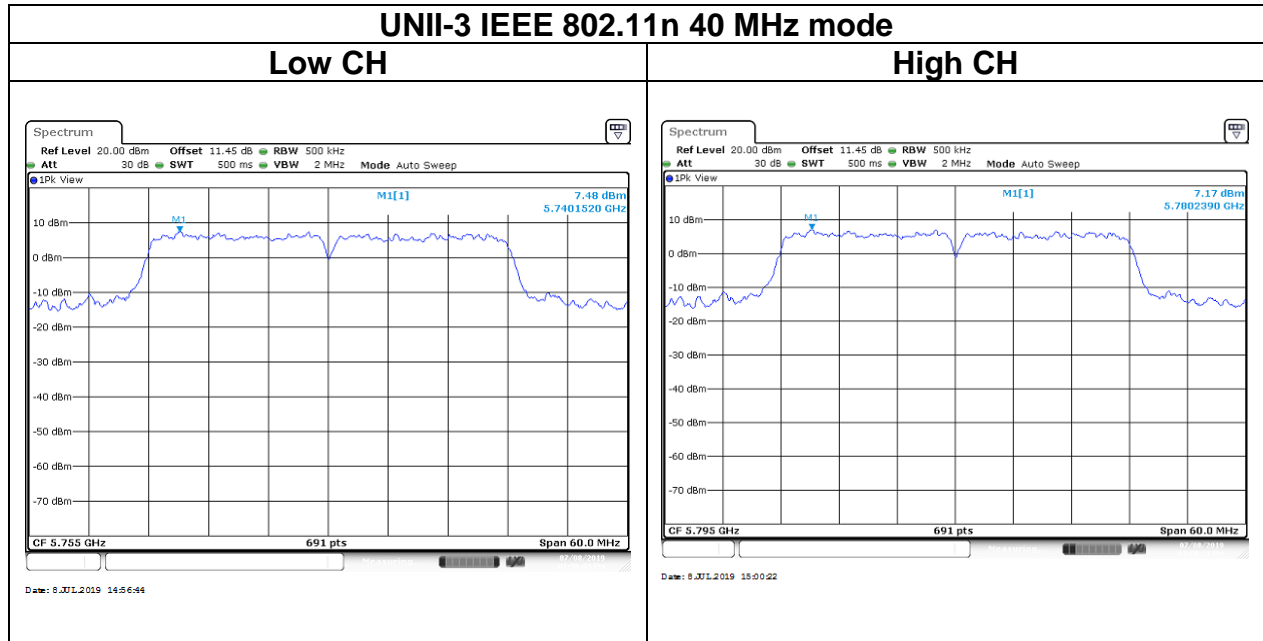

4.5 RADIATION BANDEDGE AND SPURIOUS EMISSION

4.5.1 Test Limit

FCC according to §15.407, §15.209 and §15.205,

Below 30 MHz

Frequency	Field Strength (microvolts/m)	Magnetic H-Field (microamperes/m)	Measurement Distance (metres)
9-490 kHz	2,400/F (F in kHz)	2,400/F (F in kHz)	300
490-1,705 kHz	24,000/F (F in kHz)	24,000/F (F in kHz)	30
1.705-30 MHz	30	N/A	30

Above 30 MHz

Frequency (MHz)	Field Strength microvolts/m at 3 metres (watts, e.i.r.p.)	
	Transmitters	Receivers
30-88	100 (3 nW)	100 (3 nW)
88-216	150 (6.8 nW)	150 (6.8 nW)
216-960	200 (12 nW)	200 (12 nW)
Above 960	500 (75 nW)	500 (75 nW)

UNII-1 :

For transmitters operating in the band 5150-5250 MHz, all emissions outside the band 5150-5350 MHz shall not exceed -27 dBm/MHz e.i.r.p. However, any unwanted emissions that fall into the band 5250-5350 MHz must be 26 dBc, when measured using a resolution bandwidth between 1 and 5% of the occupied bandwidth, above 5.25 GHz. Otherwise, the transmission is considered as intentional and the devices shall implement dynamic frequency selection (DFS) and transmitter power control (TPC) as per the requirements for the band 5250-5350 MHz

UNII-2a and 2c :

For devices with operating frequencies in the band 5250-5350 MHz but having a channel bandwidth that overlaps the band 5150-5250 MHz, the devices' unwanted emission shall not exceed -27 dBm/MHz e.i.r.p. outside the band 5150-5350 MHz and its power shall comply with the spectral power density for operation within the band 5150-5250 MHz. The device shall be labelled "for indoor use only." Emissions outside the band 5470-5725 MHz shall not exceed -27 dBm/MHz e.i.r.p.

UNII-3:

All emissions shall be limited to a level of -27 dBm/MHz at 75 MHz or more above or below the band edge increasing linearly to 10 dBm/MHz at 25 MHz above or below the band edge, and from 25 MHz above or below the band edge increasing linearly to a level of 15.6 dBm/MHz at 5 MHz above or below the band edge, and from 5 MHz above or below the band edge increasing linearly to a level of 27 dBm/MHz at the band edge.

Report No.: T190315W01-RP4

4.5.2 Test Procedure

Test method Refer as KDB 789033 D02 v02r01, Section G.3, G.4, G.5, and G.6,.

1. The EUT is placed on a turntable, Above 1 GHz is 1.5m and below 1 GHz is 0.8m above ground plane. The EUT Configured un accordance with ANSI C63.10: 2013, and the EUT set in a continuous mode.
2. The turntable shall be rotated for 360 degrees to determine the position of maximum emission level. And EUT is set 3m away from the receiving antenna, which is scanned from 1m to 4m above the ground plane to find out the highest emissions. Measurement are made polarized in both the vertical and the horizontal positions with antenna.
3. Span shall wide enough to full capture the emission measured. The SA from 9kHz to 26.5GHz set to the low, Mid and High channels with the EUT transmit.
4. No emission found between lowest internal used/generated frequency to 30MHz (9KHz~30MHz)
5. The SA setting following :
 - (1) Below 1G : RBW = 100kHz, VBW $\geq 3 \times$ RBW, Sweep = Auto, Detector = Peak, Trace = Max hold.
 - (2) Above 1G :
 - (2.1) For Peak measurement : RBW = 1MHz, VBW ≥ 3 RBW, Sweep = Auto, Detector = Peak, Trace = Max hold.
 - (2.2) For Average measurement : RBW = 1MHz, VBW
 - If Duty Cycle $\geq 98\%$, VBW=10Hz.
 - If Duty Cycle $< 98\%$, VBW=1/T.

Configuration	Duty Cycle (%)	T(ms)	1/T (Hz)	VBW Setting
802.11a	100%	100.0000	-	10Hz
802.11n 20MHz	100%	100.0000	-	10Hz
802.11n 40MHz	100%	100.0000	-	10Hz
802.11ac VHT80	100%	100.0000	-	10Hz

Report No.: T190315W01-RP4

4.5.3 Test Setup

9kHz ~ 30MHz

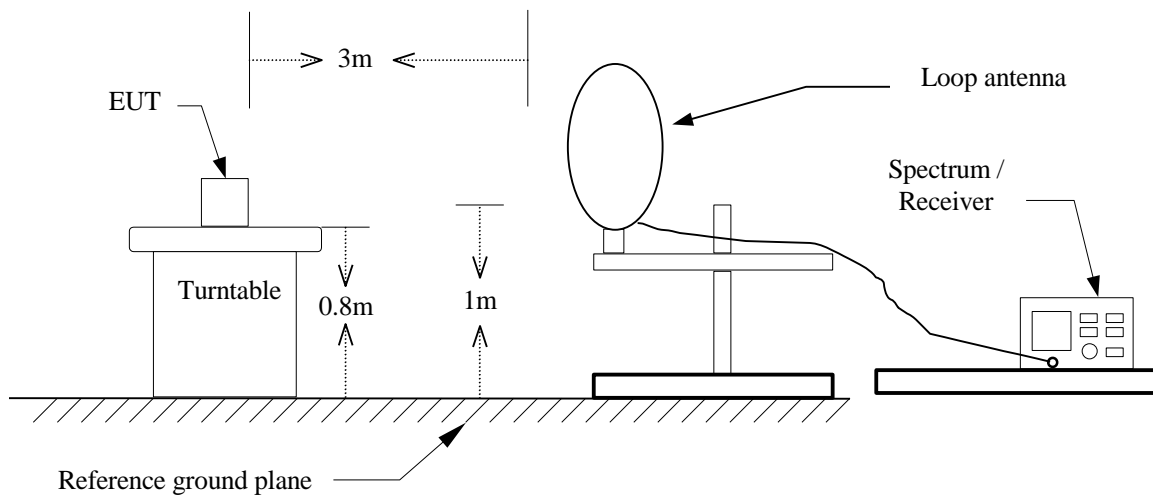

30MHz ~ 1GHz

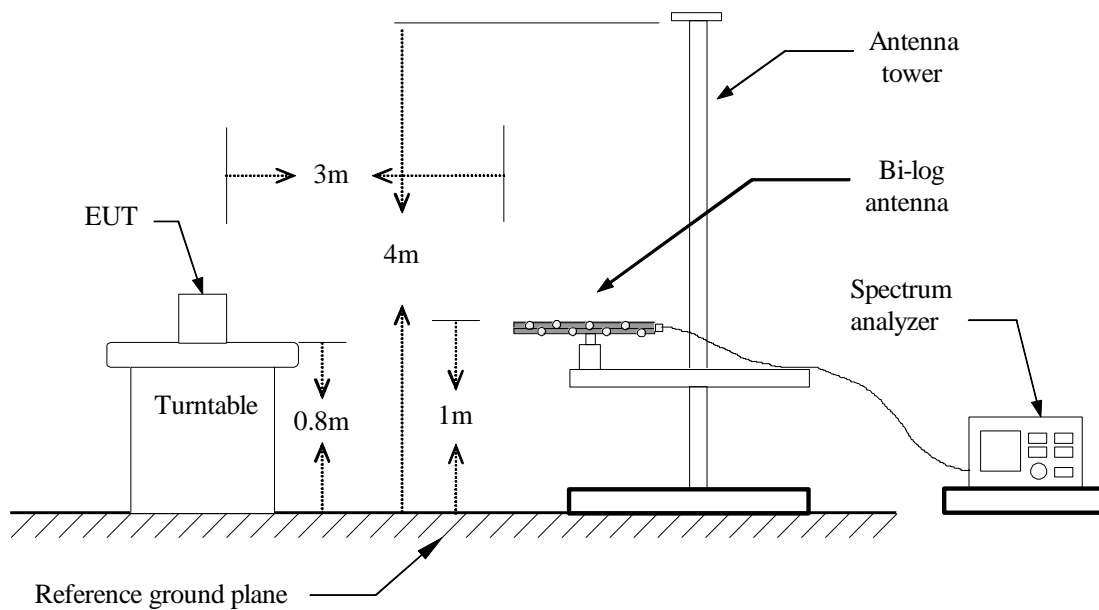

Above 1 GHz

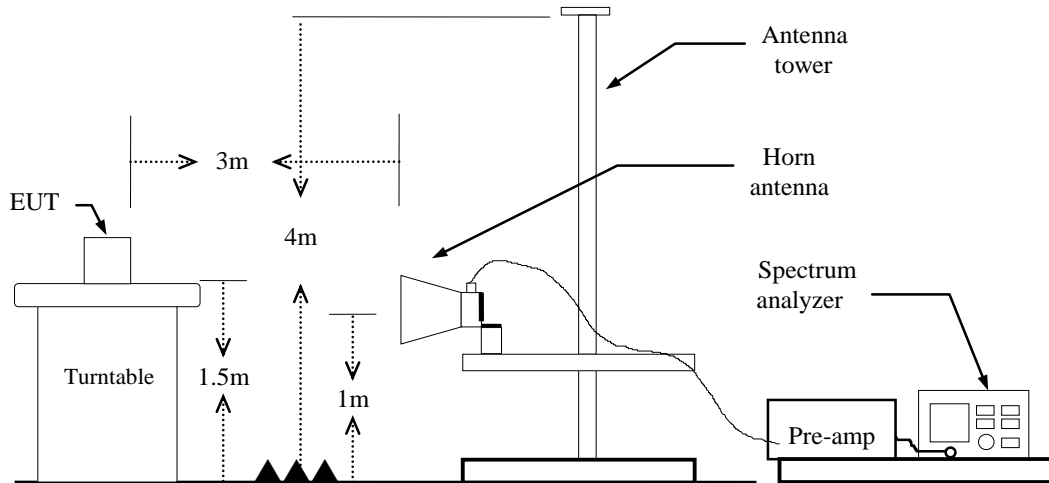

4.5.4 Test Result

Test Data

Band Edge Test Data for UNII-1

Test Mode	IEEE 802.11a / 5180MHZ	Temp/Hum	27.5(°C)/ 51.8%RH
Test Item	Band Edge	Test Date	July 11, 2019
Polarize	Horizontal	Test Engineer	Dally Hong
Detector	Peak / Average		

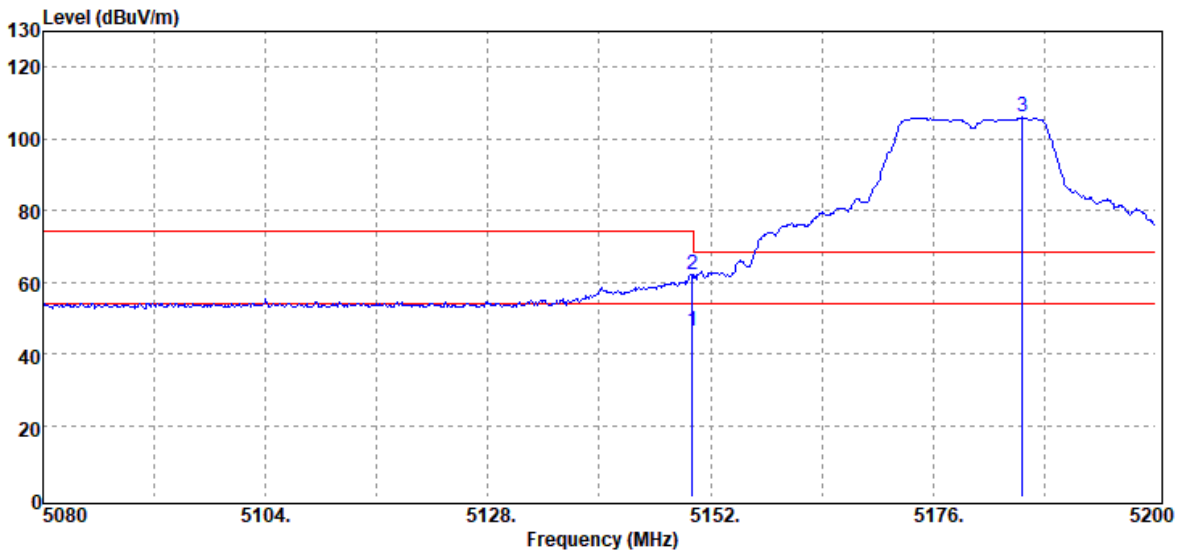

Frequency (MHz)	Reading (dBuV)	Correct Factor (dB/m)	Result (dBuV/m)	Limit (dBuV/m)	Margin (dB)	Remark
5150.00	41.29	4.92	46.21	54.00	-7.79	Average
5150.00	57.27	4.92	62.19	74.00	-11.81	Peak
5185.60	100.99	4.95	105.94	68.20	-	-

Test Mode	IEEE 802.11n 20 MHz / 5180MHZ	Temp/Hum	27.5(°C)/ 51.8%RH
Test Item	Band Edge	Test Date	July 11, 2019
Polarize	Horizontal	Test Engineer	Dally Hong
Detector	Peak / Average		

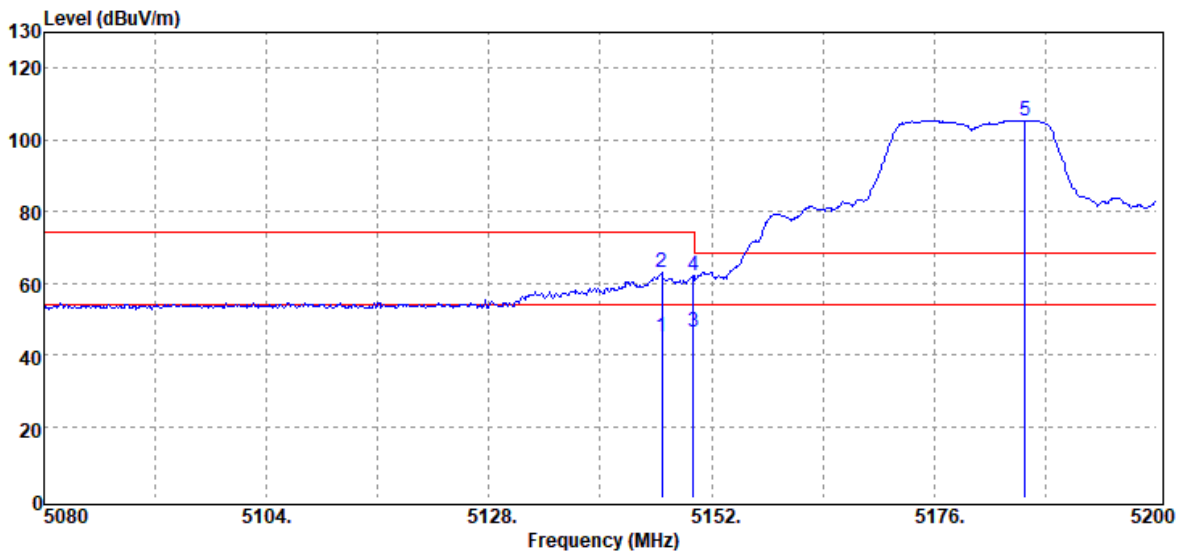

Frequency (MHz)	Reading (dBuV)	Correct Factor (dB/m)	Result (dBuV/m)	Limit (dBuV/m)	Margin (dB)	Remark
5146.60	39.95	4.92	44.87	54.00	-9.13	Average
5146.60	58.01	4.92	62.93	74.00	-11.07	Peak
5150.00	41.37	4.92	46.29	54.00	-7.71	Average
5150.00	57.12	4.92	62.04	74.00	-11.96	Peak
5185.84	100.41	4.95	105.36	68.20	-	-

Test Mode	IEEE 802.11n 40 MHz / 5190MHz	Temp/Hum	27.5(°C)/ 51.8%RH
Test Item	Band Edge	Test Date	July 11, 2019
Polarize	Horizontal	Test Engineer	Dally Hong
Detector	Peak / Average		

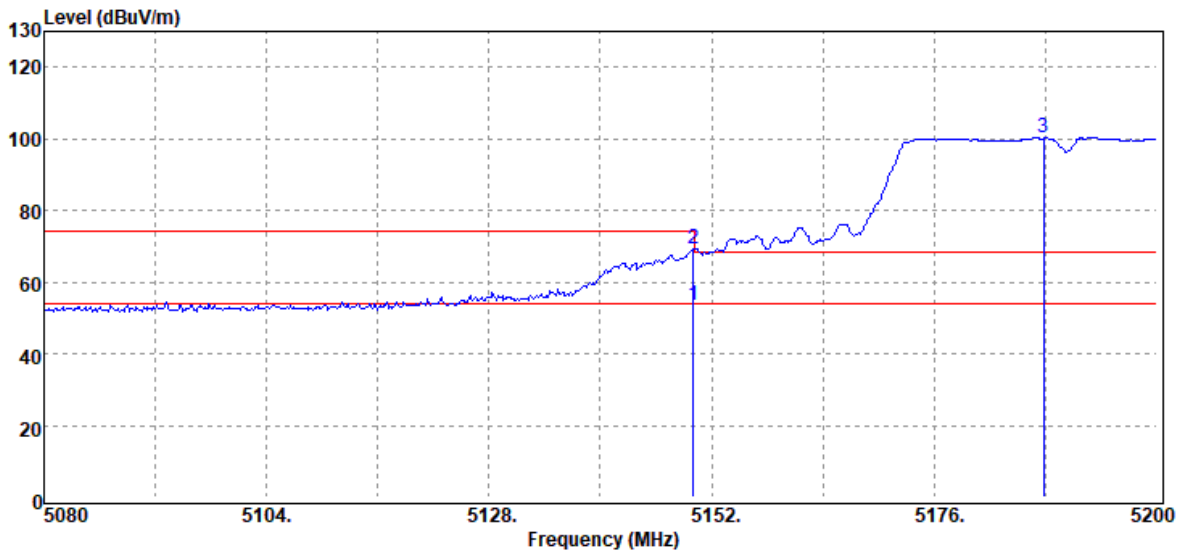

Frequency (MHz)	Reading (dBuV)	Correct Factor (dB/m)	Result (dBuV/m)	Limit (dBuV/m)	Margin (dB)	Remark
5150.00	48.39	4.92	53.31	54.00	-0.69	Average
5150.00	64.20	4.92	69.12	74.00	-4.88	Peak
5187.76	95.50	4.95	100.45	68.20	-	-

Test Mode	I EEE 802.11ac VHT80 / 5210MHZ	Temp/Hum	27.5(°C)/ 51.8%RH
Test Item	Band Edge	Test Date	July 11, 2019
Polarize	Horizontal	Test Engineer	Dally Hong
Detector	Peak / Average		

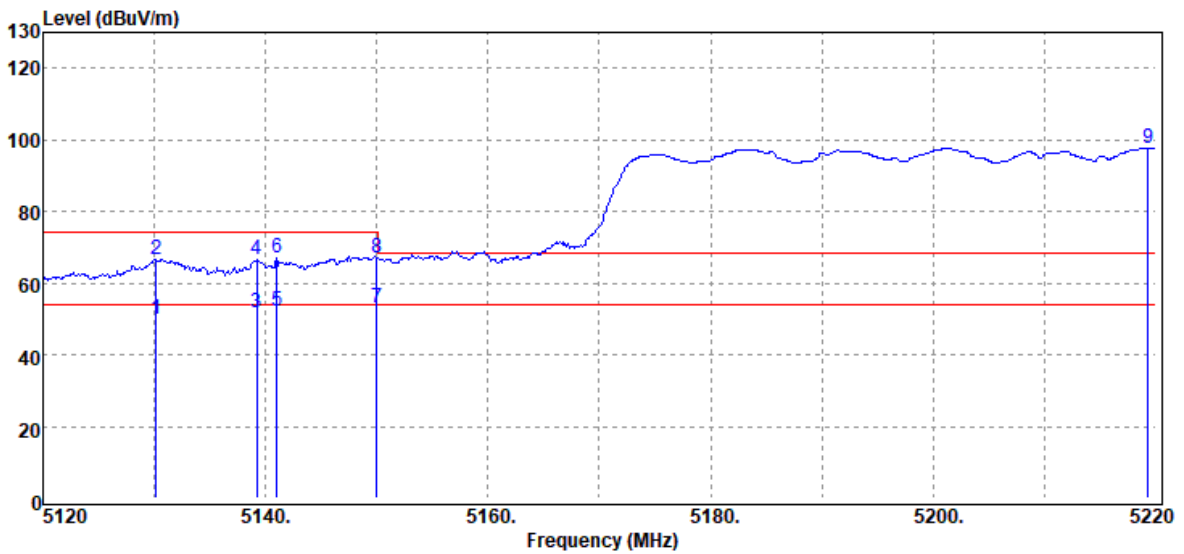

Frequency (MHz)	Reading (dBuV)	Correct Factor (dB/m)	Result (dBuV/m)	Limit (dBuV/m)	Margin (dB)	Remark
5130.20	45.17	4.91	50.08	54.00	-3.92	Average
5130.20	61.75	4.91	66.66	74.00	-7.34	Peak
5139.20	46.96	4.91	51.87	54.00	-2.13	Average
5139.20	61.48	4.91	66.39	74.00	-7.61	Peak
5141.00	47.27	4.92	52.19	54.00	-1.81	Average
5141.00	62.08	4.92	67.00	74.00	-7.00	Peak
5150.00	48.15	4.92	53.07	54.00	-0.93	Average
5150.00	62.06	4.92	66.98	74.00	-7.02	Peak
5219.30	92.73	4.92	97.65	68.20	-	-

Report No.: T190315W01-RP4

Band Edge Test Data for UNII-2a

Test Mode	IEEE 802.11a / 5320MHz	Temp/Hum	27.5(°C) / 51.8%RH
Test Item	Band Edge	Test Date	July 11, 2019
Polarize	Horizontal	Test Engineer	Dally Hong
Detector	Peak / Average		

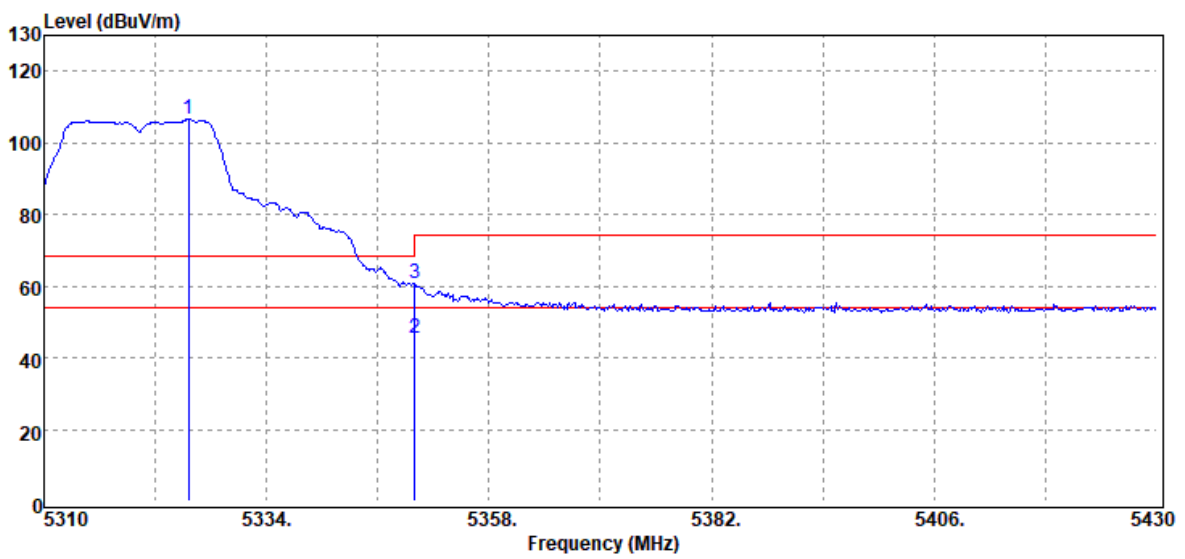

Frequency (MHz)	Reading (dBuV)	Correct Factor (dB/m)	Result (dBuV/m)	Limit (dBuV/m)	Margin (dB)	Remark
5325.60	101.42	5.09	106.51	68.20	-	-
5350.00	40.35	5.21	45.56	54.00	-8.44	Average
5350.00	55.36	5.21	60.57	74.00	-13.43	Peak



Report No.: T190315W01-RP4

Test Mode	IEEE 802.11n 20 MHz / 5320MHz	Temp/Hum	27.5(°C)/ 51.8%RH
Test Item	Band Edge	Test Date	July 11, 2019
Polarize	Horizontal	Test Engineer	Dally Hong
Detector	Peak / Average		

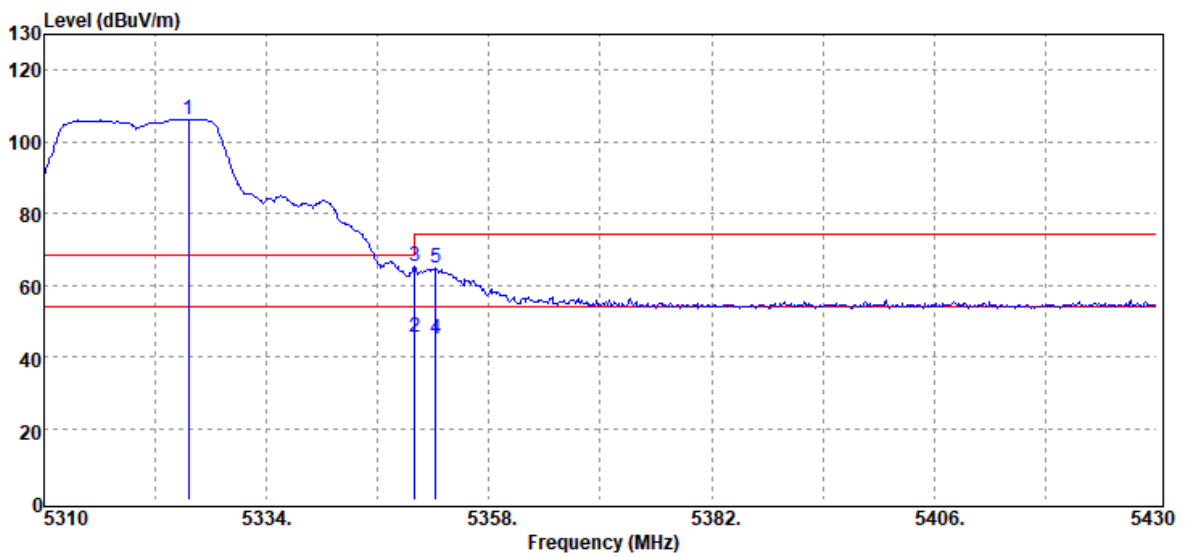

Frequency (MHz)	Reading (dBUV)	Correct Factor (dB/m)	Result (dBUV/m)	Limit (dBUV/m)	Margin (dB)	Remark
5325.60	101.26	5.09	106.35	68.20	-	-
5350.00	40.23	5.21	45.44	54.00	-8.56	Average
5350.00	60.24	5.21	65.45	74.00	-8.55	Peak
5352.24	39.59	5.22	44.81	54.00	-9.19	Average
5352.24	59.74	5.22	64.96	74.00	-9.04	Peak



Report No.: T190315W01-RP4

Page: 85 / 192
Rev.: 01

Test Mode	IEEE 802.11n 40 MHz / 5310MHz	Temp/Hum	27.5(°C)/ 51.8%RH
Test Item	Band Edge	Test Date	July 11, 2019
Polarize	Horizontal	Test Engineer	Dally Hong
Detector	Peak / Average		

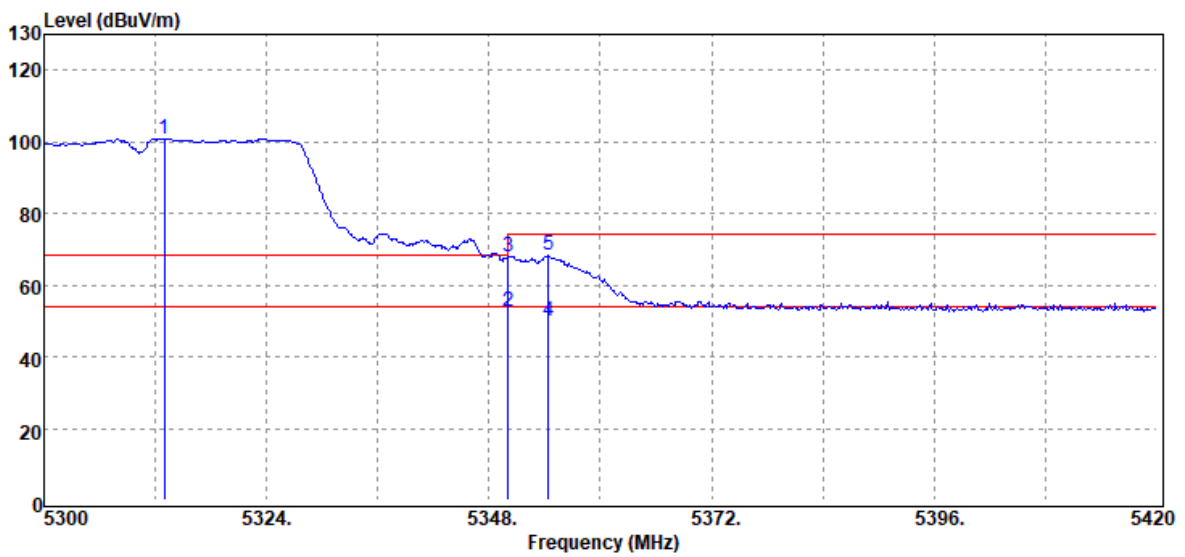

Frequency (MHz)	Reading (dBuV)	Correct Factor (dB/m)	Result (dBuV/m)	Limit (dBuV/m)	Margin (dB)	Remark
5312.96	95.75	5.04	100.79	68.20	-	-
5350.04	47.28	5.22	52.50	54.00	-1.50	Average
5350.04	62.69	5.22	67.91	74.00	-6.09	Peak
5354.36	44.68	5.23	49.91	54.00	-4.09	Average
5354.36	63.08	5.23	68.31	74.00	-5.69	Peak

Test Mode	IEEE 802.11ac VHT80 / 5290MHz	Temp/Hum	27.5(°C)/ 51.8%RH
Test Item	Band Edge	Test Date	July 11, 2019
Polarize	Horizontal	Test Engineer	Dally Hong
Detector	Peak / Average		

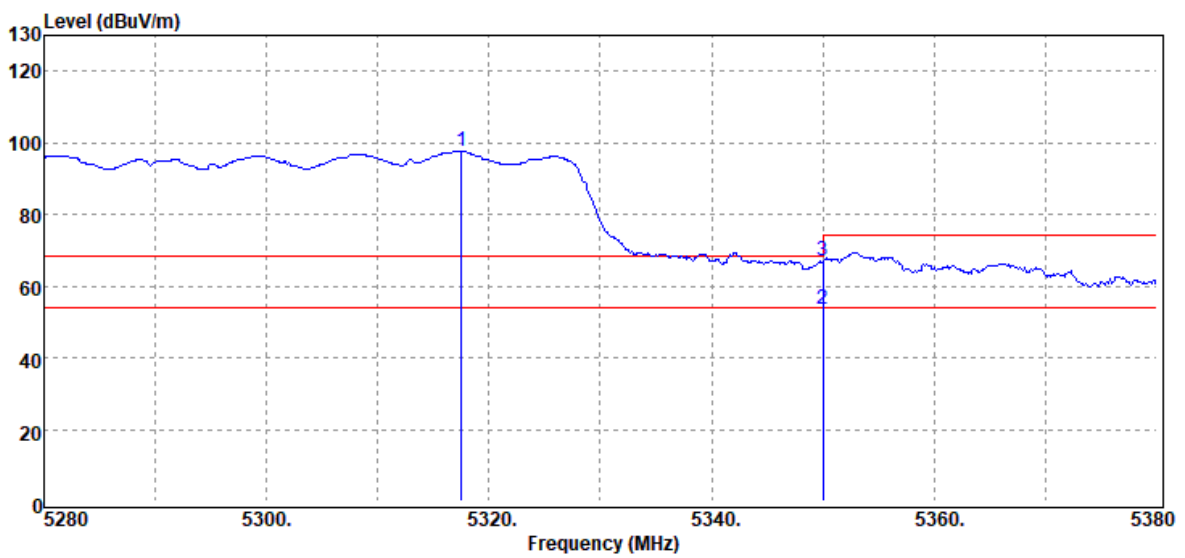

Frequency (MHz)	Reading (dBuV)	Correct Factor (dB/m)	Result (dBuV/m)	Limit (dBuV/m)	Margin (dB)	Remark
5317.50	92.51	5.05	97.56	68.20	-	-
5350.00	48.21	5.21	53.42	54.00	-0.58	Average
5350.00	61.69	5.21	66.90	74.00	-7.10	Peak

Band Edge Test Data for UNII-2c

Test Mode	IEEE 802.11a / 5500MHz	Temp/Hum	27.5(°C) / 51.8%RH
Test Item	Band Edge	Test Date	July 11, 2019
Polarize	Horizontal	Test Engineer	Dally Hong
Detector	Peak / Average		

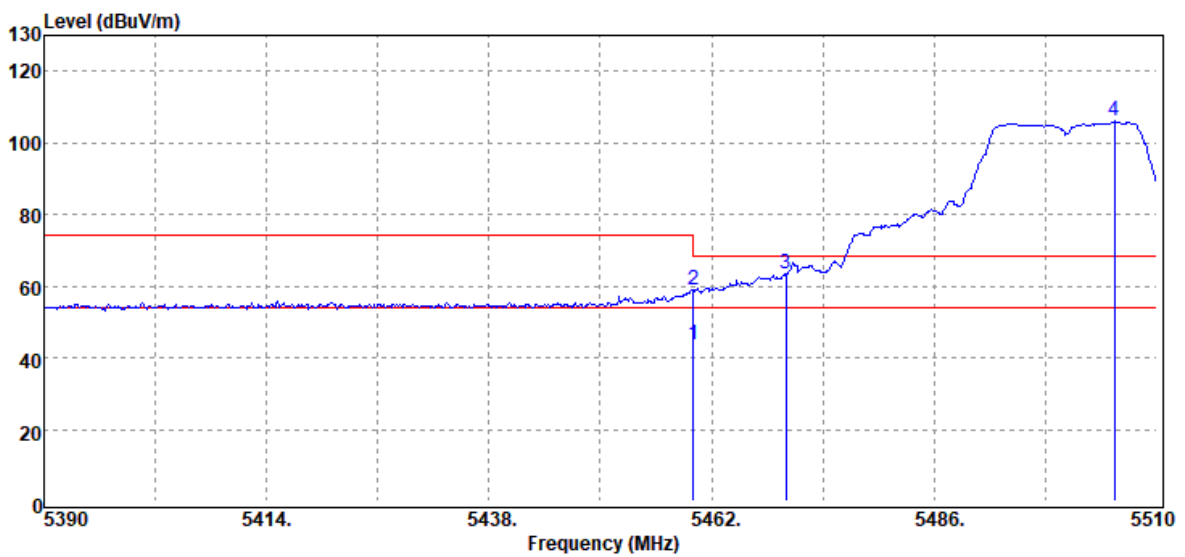

Frequency (MHz)	Reading (dBuV)	Correct Factor (dB/m)	Result (dBuV/m)	Limit (dBuV/m)	Margin (dB)	Remark
5460.00	38.02	5.63	43.65	54.00	-10.35	Average
5460.00	53.44	5.63	59.07	68.20	-9.13	Peak
5470.00	57.92	5.65	63.57	68.20	-4.63	Peak
5505.44	100.25	5.71	105.96	68.20	-	-

Report No.: T190315W01-RP4

Test Mode	IEEE 802.11a / 5700 MHz	Temp/Hum	27.5(°C)/ 51.8%RH
Test Item	Band Edge	Test Date	July 11, 2019
Polarize	Horizontal	Test Engineer	Dally Hong
Detector	Peak / Average		

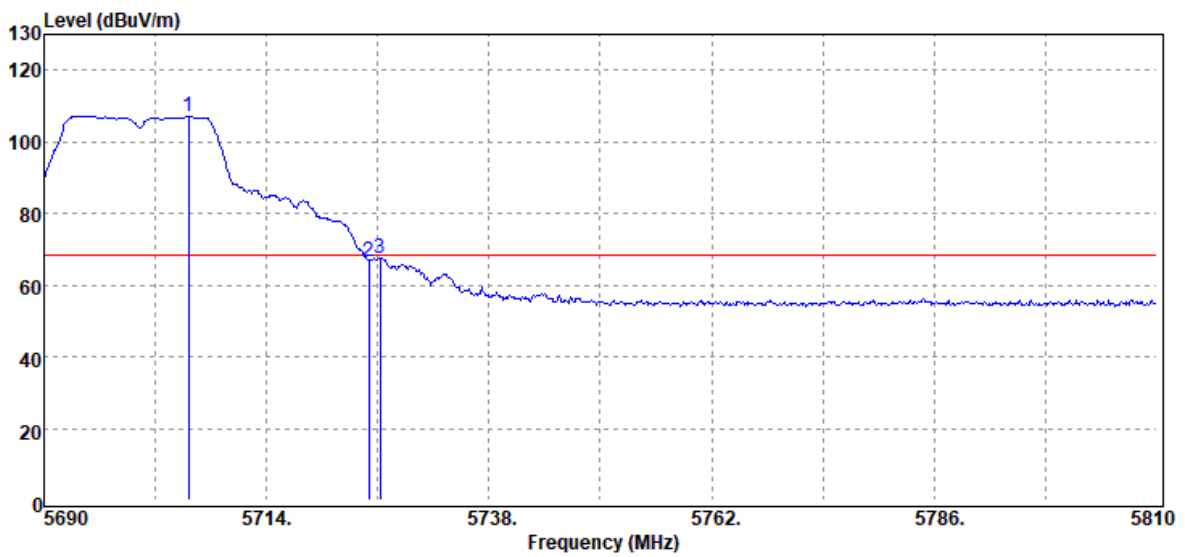

Frequency (MHz)	Reading (dBuV)	Correct Factor (dB/m)	Result (dBuV/m)	Limit (dBuV/m)	Margin (dB)	Remark
5705.60	100.87	6.32	107.19	68.20	-	-
5725.00	60.36	6.34	66.70	68.20	-1.50	Peak
5726.24	61.33	6.34	67.67	68.20	-0.53	Peak

Test Mode	IEEE 802.11n 20 MHz / 5500MHz	Temp/Hum	27.5(°C)/ 51.8%RH
Test Item	Band Edge	Test Date	July 11, 2019
Polarize	Horizontal	Test Engineer	Dally Hong
Detector	Peak / Average		

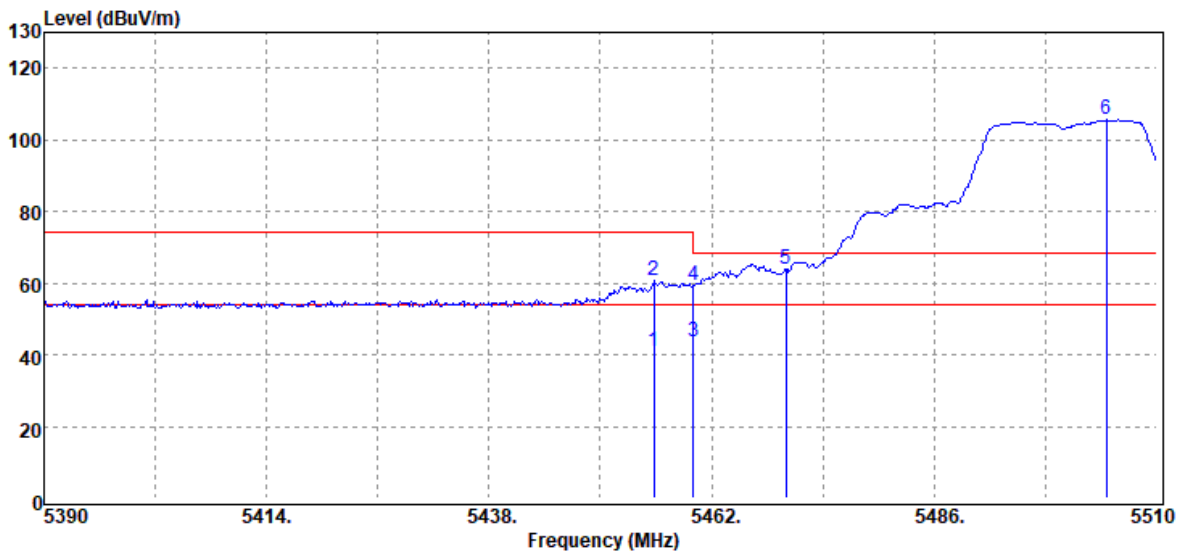

Frequency (MHz)	Reading (dBUV)	Correct Factor (dB/m)	Result (dBUV/m)	Limit (dBUV/m)	Margin (dB)	Remark
5455.76	35.23	5.62	40.85	54.00	-13.15	Average
5455.76	55.06	5.62	60.68	74.00	-13.32	Peak
5460.00	38.07	5.63	43.70	54.00	-10.30	Average
5460.00	53.90	5.63	59.53	68.20	-8.67	Peak
5470.00	58.43	5.65	64.08	68.20	-4.12	Peak
5504.60	99.79	5.70	105.49	68.20	37.29	Peak

Test Mode	IEEE 802.11n 20 MHz / 5700 MHz	Temperature	27.5(°C)/ 51.8%RH
Test Item	Band Edge	Test Date	July 11, 2019
Polarize	Horizontal	Test Engineer	Dally Hong
Detector	Peak		

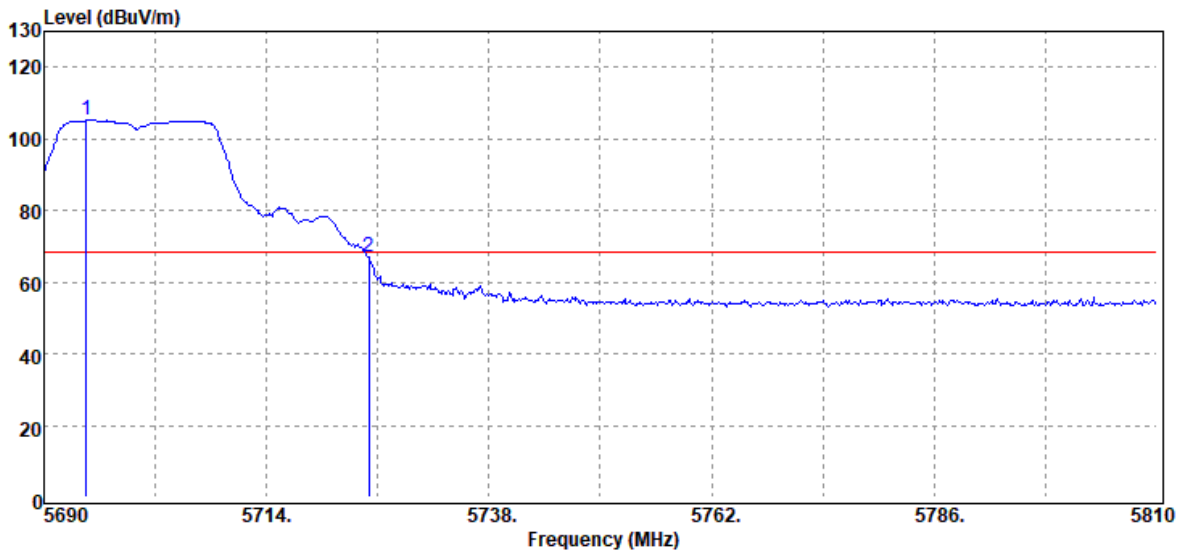

Frequency (MHz)	Reading (dBuV)	Correct Factor (dB/m)	Result (dBuV/m)	Limit (dBuV/m)	Margin (dB)	Remark
5694.56	98.91	6.28	105.19	68.20	-	-
5725.00	60.46	6.34	66.80	68.20	-1.40	Peak

Test Mode	IEEE 802.11n 40 MHz / 5510 MHz	Temp/Hum	27.5(°C)/ 51.8%RH
Test Item	Band Edge	Test Date	July 11, 2019
Polarize	Horizontal	Test Engineer	Dally Hong
Detector	Peak / Average		

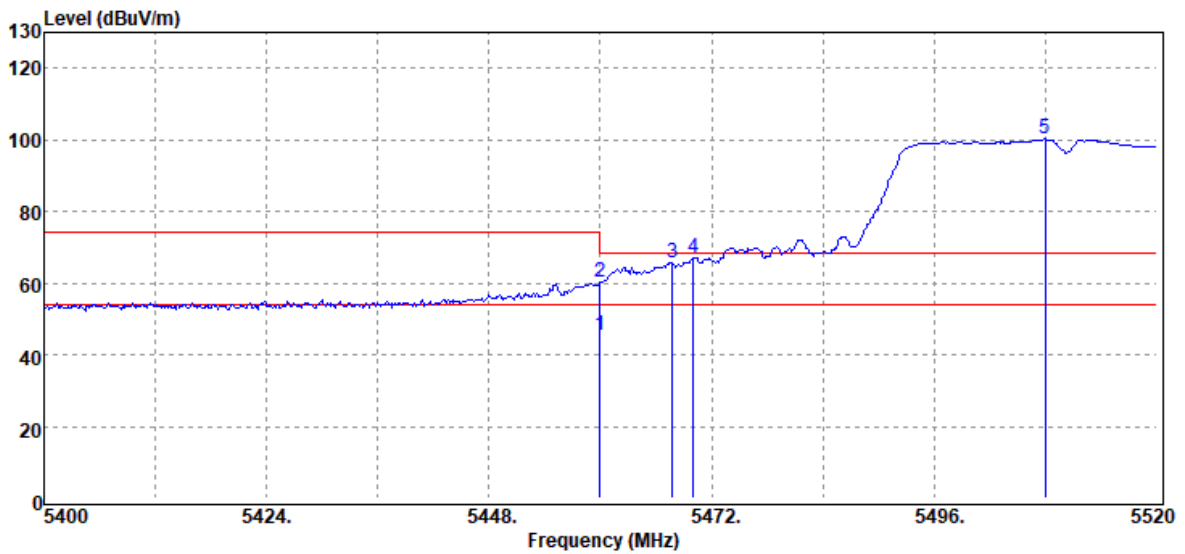

Frequency (MHz)	Reading (dBUV)	Correct Factor (dB/m)	Result (dBUV/m)	Limit (dBUV/m)	Margin (dB)	Remark
5460.00	39.89	5.63	45.52	54.00	-8.48	Average
5460.00	54.69	5.63	60.32	68.20	-7.88	Peak
5467.80	60.05	5.64	65.69	68.20	-2.51	Peak
5470.00	61.17	5.65	66.82	68.20	-1.38	Peak
5508.00	94.55	5.70	100.25	68.20	-	-



Report No.: T190315W01-RP4

Test Mode	IEEE 802.11n 40 MHz / 5670 MHz	Temp/Hum	27.5(°C)/ 51.8%RH
Test Item	Band Edge	Test Date	July 11, 2019
Polarize	Horizontal	Test Engineer	Dally Hong
Detector	Peak		

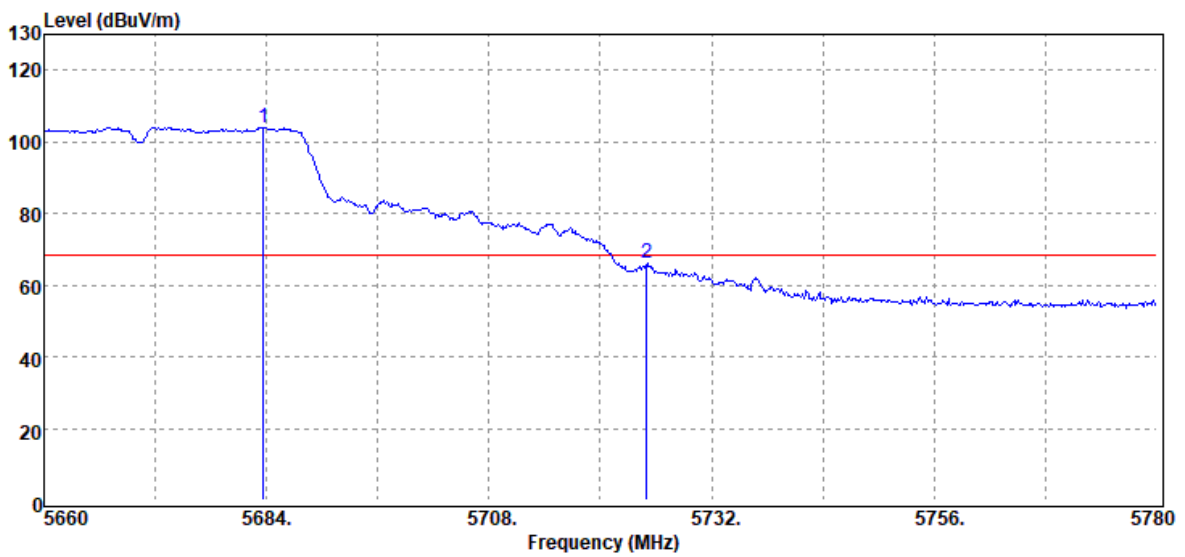

Frequency (MHz)	Reading (dBuV)	Correct Factor (dB/m)	Result (dBuV/m)	Limit (dBuV/m)	Margin (dB)	Remark
5683.64	97.92	6.20	104.12	68.20	-	-
5725.00	59.86	6.34	66.20	68.20	-2.00	Peak

Test Mode	IEEE 802.11ac VHT80 / 5530 MHz	Temp/Hum	27.5(°C)/ 51.8%RH
Test Item	Band Edge	Test Date	July 11, 2019
Polarize	Horizontal	Test Engineer	Dally Hong
Detector	Peak / Average		

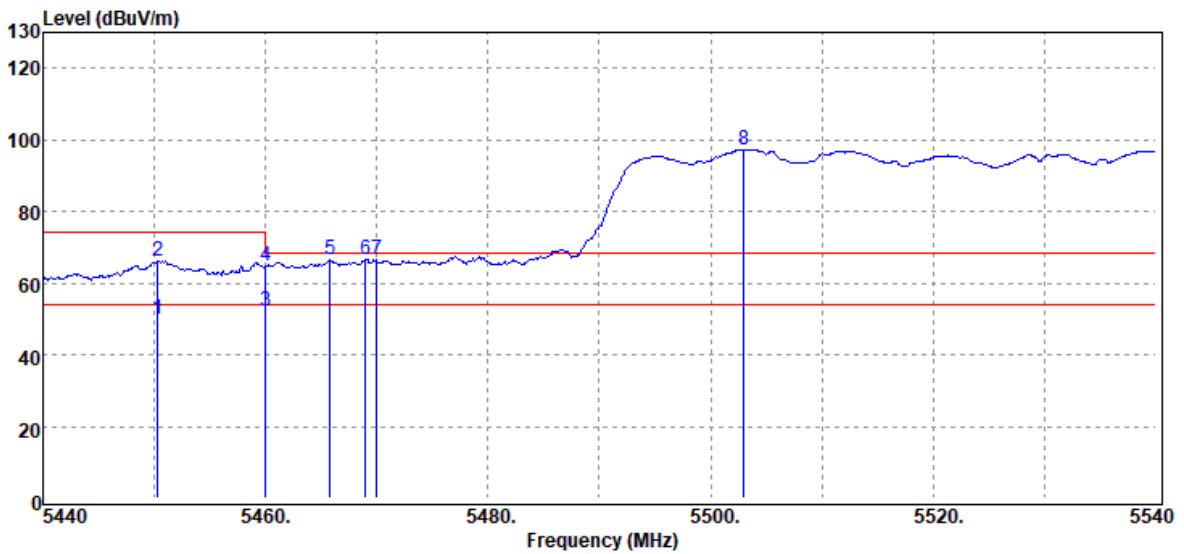

Frequency (MHz)	Reading (dBUV)	Correct Factor (dB/m)	Result (dBUV/m)	Limit (dBUV/m)	Margin (dB)	Remark
5450.30	44.25	5.60	49.85	54.00	-4.15	Average
5450.30	60.47	5.60	66.07	74.00	-7.93	Peak
5460.00	46.37	5.63	52.00	54.00	-2.00	Average
5460.00	59.27	5.63	64.90	68.20	-3.30	Peak
5465.80	61.04	5.64	66.68	68.20	-1.52	Peak
5469.00	60.97	5.65	66.62	68.20	-1.58	Peak
5470.00	60.72	5.65	66.37	68.20	-1.83	Peak
5503.00	91.56	5.71	97.27	68.20	-	-

Band Edge Test Data for UNII-3

Test Mode	IEEE 802.11a / 5745 MHz	Temp/Hum	27.5(°C)/ 51.8%RH
Test Item	Band Edge	Test Date	July 11, 2019
Polarize	Horizontal	Test Engineer	Dally Hong
Detector	Peak		

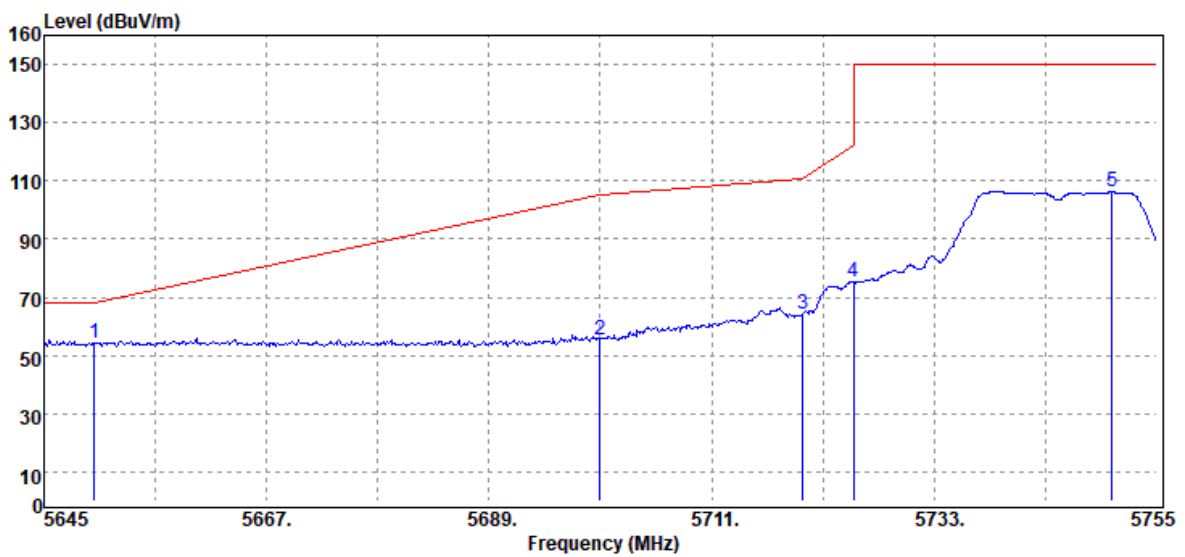

Frequency (MHz)	Reading (dBuV)	Correct Factor (dB/m)	Result (dBuV/m)	Limit (dBuV/m)	Margin (dB)	Remark
5650.00	47.99	6.04	54.03	68.20	-14.17	Peak
5700.00	49.28	6.32	55.60	105.20	-49.60	Peak
5720.00	57.85	6.33	64.18	110.80	-46.62	Peak
5725.00	68.79	6.34	75.13	122.20	-47.07	Peak
5750.60	100.00	6.36	106.36	150.00	-43.64	Peak

Test Mode	IEEE 802.11a / 5825 MHz	Temp/Hum	27.5(°C)/ 51.8%RH
Test Item	Band Edge	Test Date	July 11, 2019
Polarize	Horizontal	Test Engineer	Dally Hong
Detector	Peak		

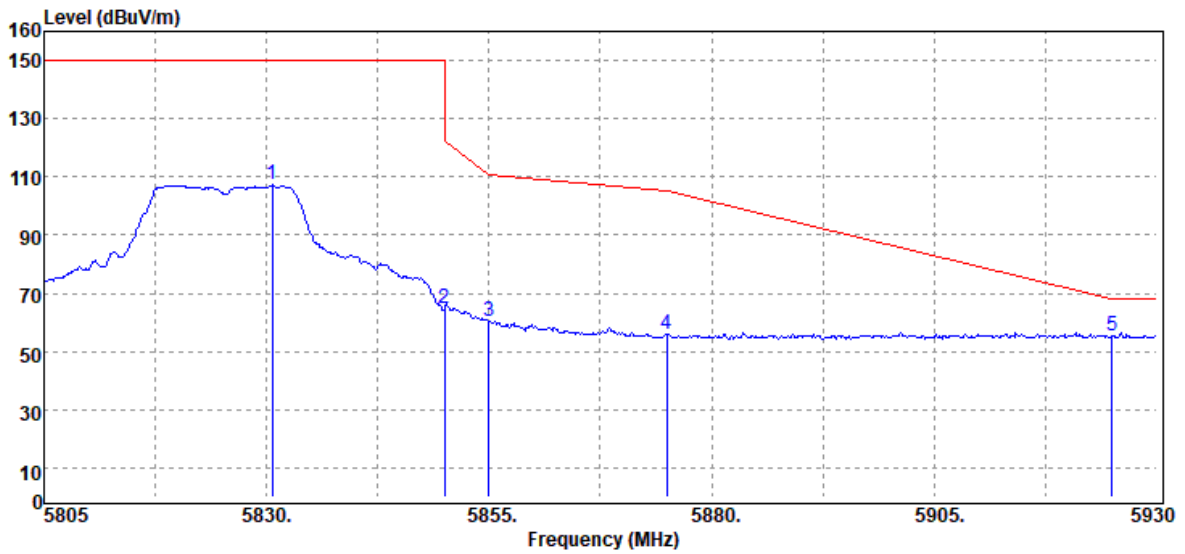

Frequency (MHz)	Reading (dBuV)	Correct Factor (dB/m)	Result (dBuV/m)	Limit (dBuV/m)	Margin (dB)	Remark
5830.63	100.84	6.33	107.17	150.00	-42.83	Peak
5850.00	58.24	6.39	64.63	122.20	-57.57	Peak
5855.00	53.88	6.38	60.26	110.80	-50.54	Peak
5875.00	49.50	6.37	55.87	105.20	-49.33	Peak
5925.00	48.74	6.42	55.16	68.20	-13.04	Peak

Test Mode	IEEE 802.11n 20 MHz / 5745 MHz	Temp/Hum	27.5(°C)/ 51.8%RH
Test Item	Band Edge	Test Date	July 11, 2019
Polarize	Horizontal	Test Engineer	Dally Hong
Detector	Peak		

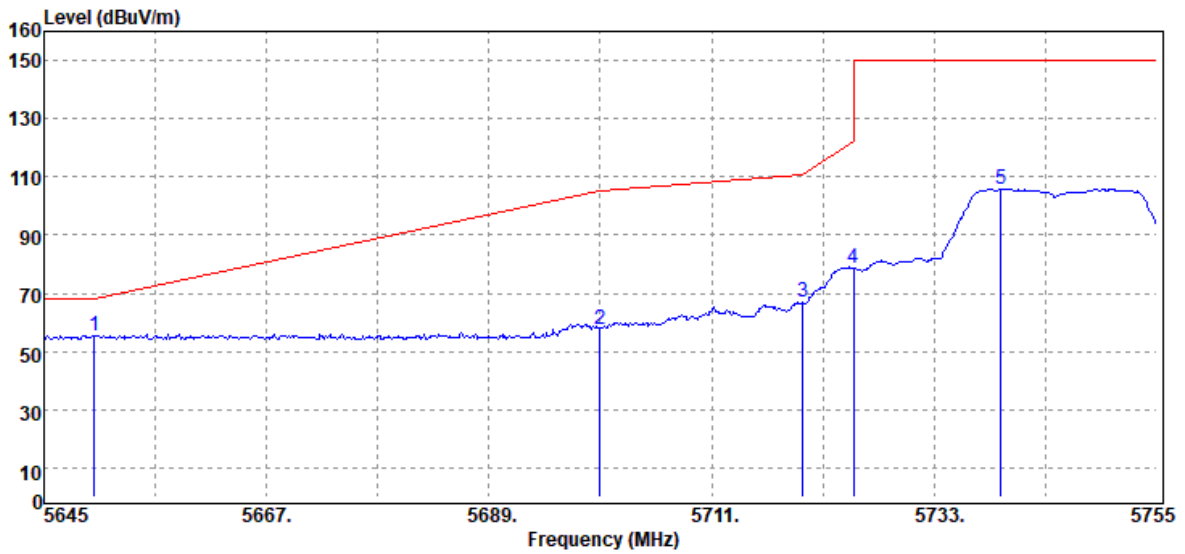

Frequency (MHz)	Reading (dBuV)	Correct Factor (dB/m)	Result (dBuV/m)	Limit (dBuV/m)	Margin (dB)	Remark
5650.00	49.18	6.04	55.22	68.20	-12.98	Peak
5700.00	51.51	6.32	57.83	105.20	-47.37	Peak
5720.00	60.72	6.33	67.05	110.80	-43.75	Peak
5725.00	72.26	6.34	78.60	122.20	-43.60	Peak
5739.60	99.40	6.36	105.76	150.00	-44.24	Peak

Test Mode	IEEE 802.11n 20 MHz / 5825 MHz	Temp/Hum	27.5(°C)/ 51.8%RH
Test Item	Band Edge	Test Date	July 11, 2019
Polarize	Horizontal	Test Engineer	Dally Hong
Detector	Peak		

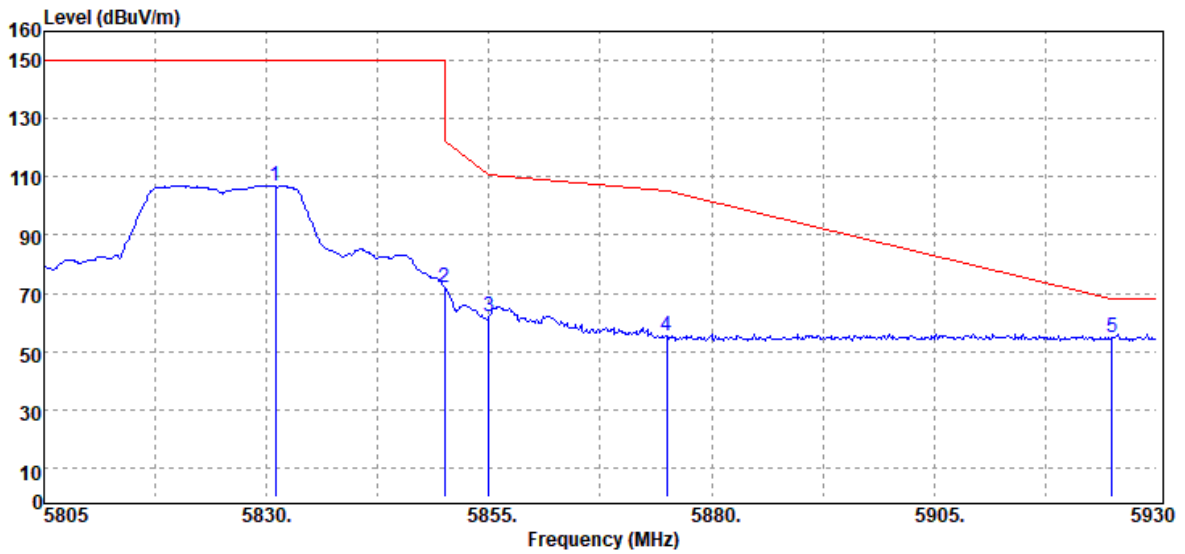

Frequency (MHz)	Reading (dBuV)	Correct Factor (dB/m)	Result (dBuV/m)	Limit (dBuV/m)	Margin (dB)	Remark
5831.00	100.49	6.33	106.82	150.00	-43.18	Peak
5850.00	65.74	6.39	72.13	122.20	-50.07	Peak
5855.00	55.76	6.38	62.14	110.80	-48.66	Peak
5875.00	49.04	6.37	55.41	105.20	-49.79	Peak
5925.00	48.47	6.42	54.89	68.20	-13.31	Peak



Report No.: T190315W01-RP4

Page: 98 / 192
Rev.: 01

Test Mode	IEEE 802.11n 40 MHz/ 5755 MHz	Temp/Hum	27.5(°C)/ 51.8%RH
Test Item	Band Edge	Test Date	July 11, 2019
Polarize	Horizontal	Test Engineer	Dally Hong
Detector	Peak		

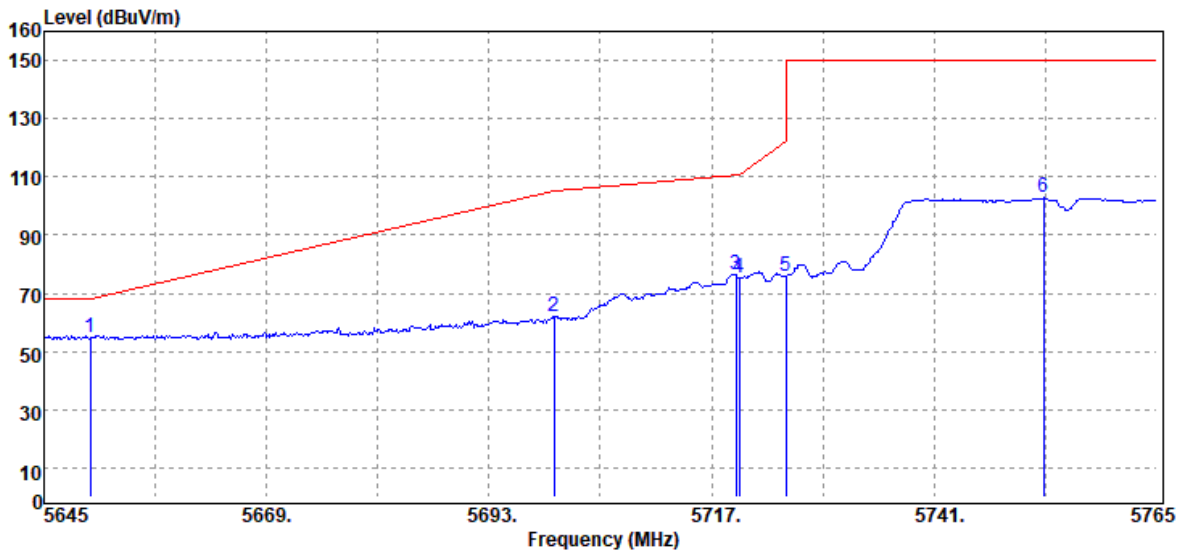

Frequency (MHz)	Reading (dBuV)	Correct Factor (dB/m)	Result (dBuV/m)	Limit (dBuV/m)	Margin (dB)	Remark
5650.00	48.56	6.04	54.60	68.20	-13.60	Peak
5700.00	55.50	6.32	61.82	105.20	-43.38	Peak
5719.64	70.19	6.33	76.52	110.70	-34.18	Peak
5720.00	69.09	6.33	75.42	110.80	-35.38	Peak
5725.00	69.65	6.34	75.99	122.20	-46.21	Peak
5752.76	96.39	6.36	102.75	150.00	-47.25	Peak

Test Mode	IEEE 802.11n 40 MHz/ 5795 MHz	Temp/Hum	27.5(°C)/ 51.8%RH
Test Item	Band Edge	Test Date	July 11, 2019
Polarize	Horizontal	Test Engineer	Dally Hong
Detector	Peak		

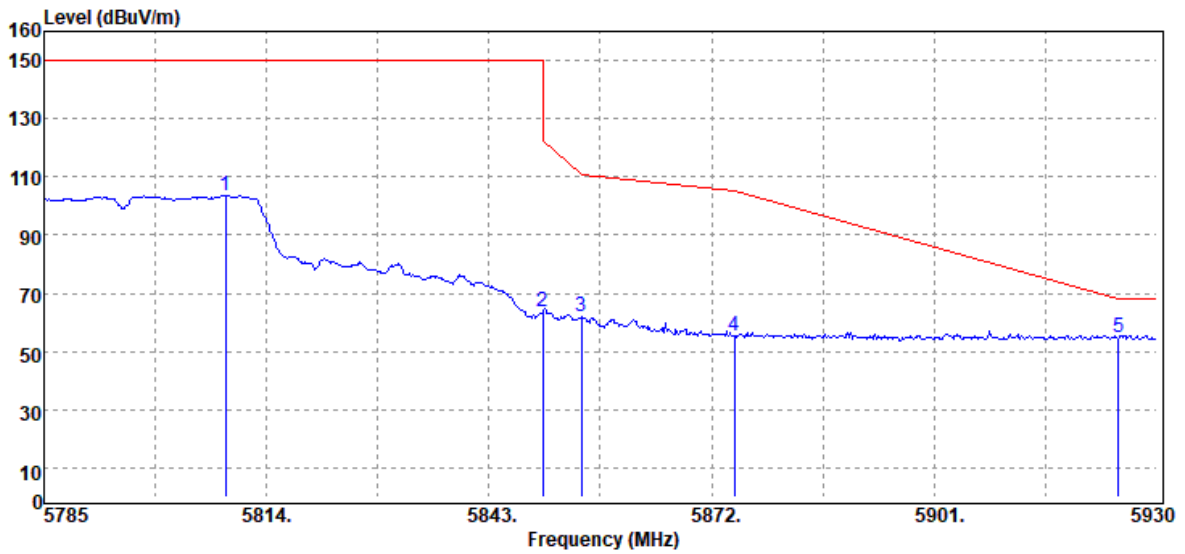

Frequency (MHz)	Reading (dBuV)	Correct Factor (dB/m)	Result (dBuV/m)	Limit (dBuV/m)	Margin (dB)	Remark
5808.64	97.43	6.29	103.72	150.00	-46.28	Peak
5850.00	57.37	6.39	63.76	122.20	-58.44	Peak
5855.00	55.44	6.38	61.82	110.80	-48.98	Peak
5875.00	48.84	6.37	55.21	105.20	-49.99	Peak
5925.00	48.42	6.42	54.84	68.20	-13.36	Peak



Report No.: T190315W01-RP4

Page: 100 / 197
Rev.: 00

Test Mode	IEEE 802.11ac VHT80 / 5775 MHz	Temp/Hum	27.5(°C) / 51.8%RH
Test Item	Band Edge	Test Date	July 11, 2019
Polarize	Horizontal	Test Engineer	Dally Hong
Detector	Peak		

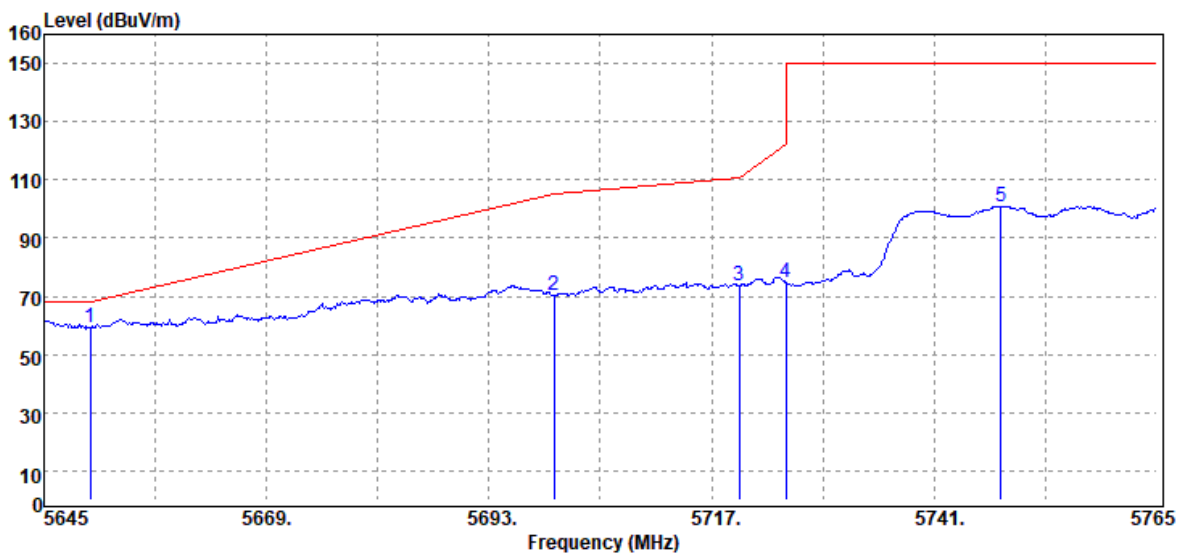

Frequency (MHz)	Reading (dBuV)	Correct Factor (dB/m)	Result (dBuV/m)	Limit (dBuV/m)	Margin (dB)	Remark
5650.00	53.19	6.04	59.23	68.20	-8.97	Peak
5700.00	63.83	6.32	70.15	105.20	-35.05	Peak
5720.00	67.26	6.33	73.59	110.80	-37.21	Peak
5725.00	68.49	6.34	74.83	122.20	-47.37	Peak
5748.20	94.51	6.37	100.88	150.00	-49.12	Peak

Report No.: T190315W01-RP4

Below 1G Test Data

Test Mode	IEEE 802.11n 40 MHz / 5610 MHz	Temp/Hum	27.5(°C)/ 51.8%RH
Test Item	30MHz-1GHz	Test Date	May 11, 2019
Polarize	Vertical	Test Engineer	Dally Hong
Detector	Peak		

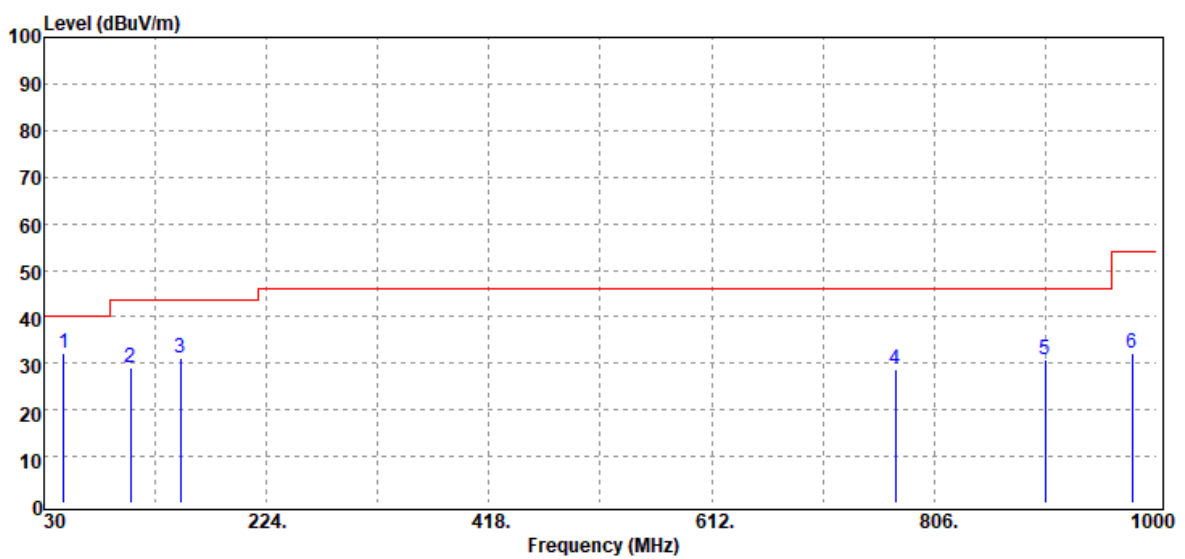

Frequency (MHz)	Reading (dBuV)	Correct Factor (dB/m)	Result (dBuV/m)	Limit (dBuV/m)	Margin (dB)	Remark
47.46	46.51	-14.26	32.25	40.00	-7.75	Peak
105.66	39.94	-11.02	28.92	43.50	-14.58	Peak
149.31	41.41	-10.10	31.31	43.50	-12.19	Peak
772.05	27.36	1.51	28.87	46.00	-17.13	Peak
903.00	26.89	4.07	30.96	46.00	-15.04	Peak
978.66	26.52	5.60	32.12	54.00	-21.88	Peak

Note: No emission found between lowest internal used/generated frequency to 30MHz(9KHz~30MHz)

Test Mode	IEEE 802.11n 40 MHz / 5550 MHz	Temp/Hum	27.5(°C)/ 51.8%RH
Test Item	30MHz-1GHz	Test Date	May 11, 2019
Polarize	Horizontal	Test Engineer	Dally Hong
Detector	Peak		

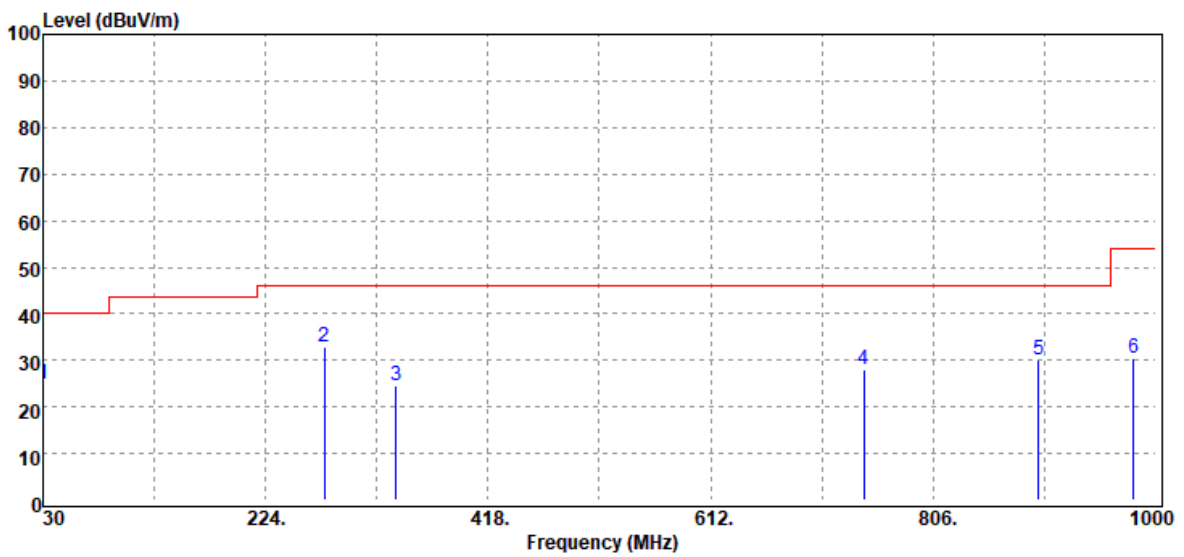

Frequency (MHz)	Reading (dBuV)	Correct Factor (dB/m)	Result (dBuV/m)	Limit (dBuV/m)	Margin (dB)	Remark
30.00	26.49	-1.51	24.98	40.00	-15.02	Peak
275.41	41.46	-8.42	33.04	46.00	-12.96	Peak
337.49	31.81	-7.10	24.71	46.00	-21.29	Peak
745.86	26.15	1.96	28.11	46.00	-17.89	Peak
898.15	26.12	4.15	30.27	46.00	-15.73	Peak
980.60	24.80	5.72	30.52	54.00	-23.48	Peak

Note: No emission found between lowest internal used/generated frequency to 30MHz(9KHz~30MHz)

Report No.: T190315W01-RP4

Above 1G Test Data for UNII-1

Test Mode	IEEE 802.11a / 5180MHZ	Temp/Hum	28.2(°C)/ 50%RH
Test Item	Harmonic	Test Date	July 12, 2019
Polarize	Vertical	Test Engineer	Dally Hong
Detector	Peak		

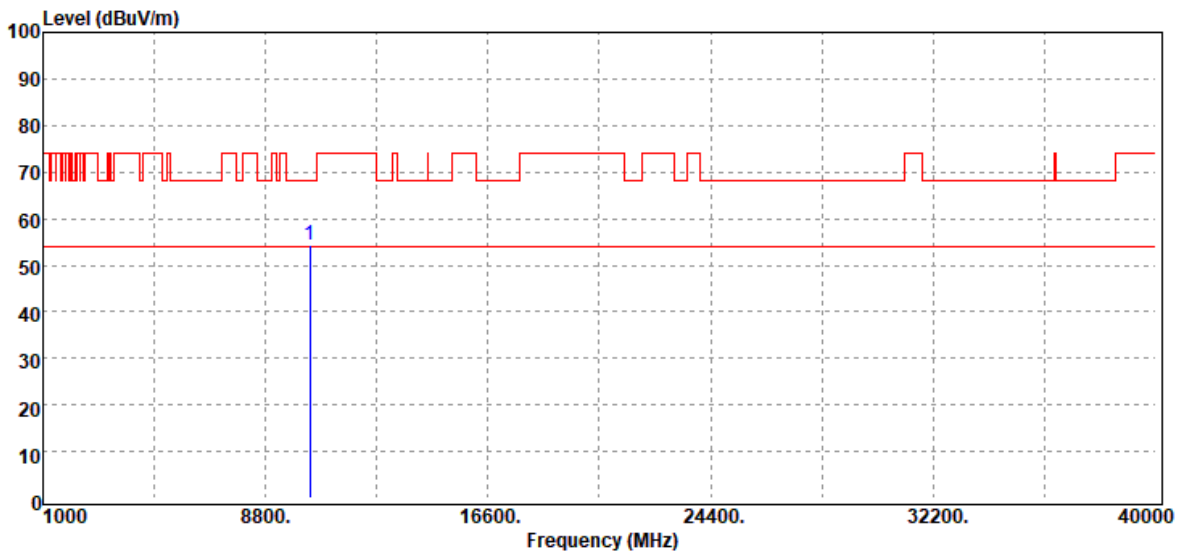

Frequency (MHz)	Reading (dBuV)	Correct Factor (dB/m)	Result (dBuV/m)	Limit (dBuV/m)	Margin (dB)	Remark
10360.00	40.25	14.12	54.37	68.20	-13.83	Peak
N/A						

Remark:

1. Measuring frequencies from 1 GHz to the 10th harmonic of highest fundamental frequency.
2. For above 1GHz, the EUT peak value was under average limit, therefore the Average value compliance with the average limit

Test Mode	IEEE 802.11a / 5180MHZ	Temp/Hum	28.2(°C)/ 50%RH
Test Item	Harmonic	Test Date	July 12, 2019
Polarize	Horizontal	Test Engineer	Dally Hong
Detector	Peak		

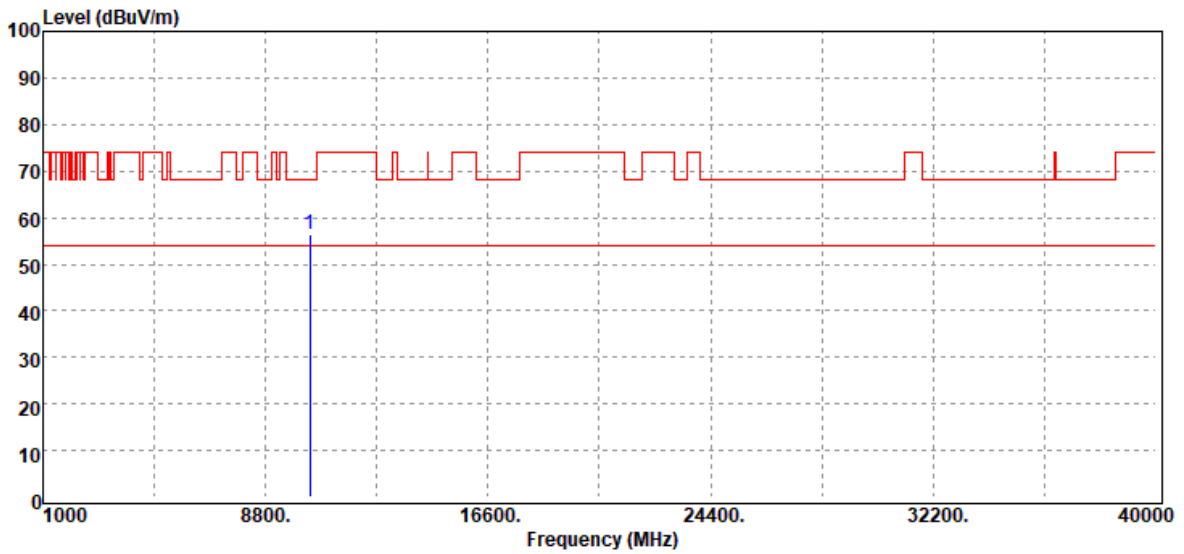

Frequency (MHz)	Reading (dBuV)	Correct Factor (dB/m)	Result (dBuV/m)	Limit (dBuV/m)	Margin (dB)	Remark
10360.00	42.38	14.12	56.50	68.20	-11.70	Peak
N/A						

Remark:

1. Measuring frequencies from 1 GHz to the 10th harmonic of highest fundamental frequency.
2. For above 1GHz, the EUT peak value was under average limit, therefore the Average value compliance with the average limit

Test Mode	IEEE 802.11a / 5220 MHZ	Temp/Hum	28.2(°C)/ 50%RH
Test Item	Horizontal	Test Date	July 12, 2019
Polarize	Vertical	Test Engineer	Dally Hong
Detector	Peak		

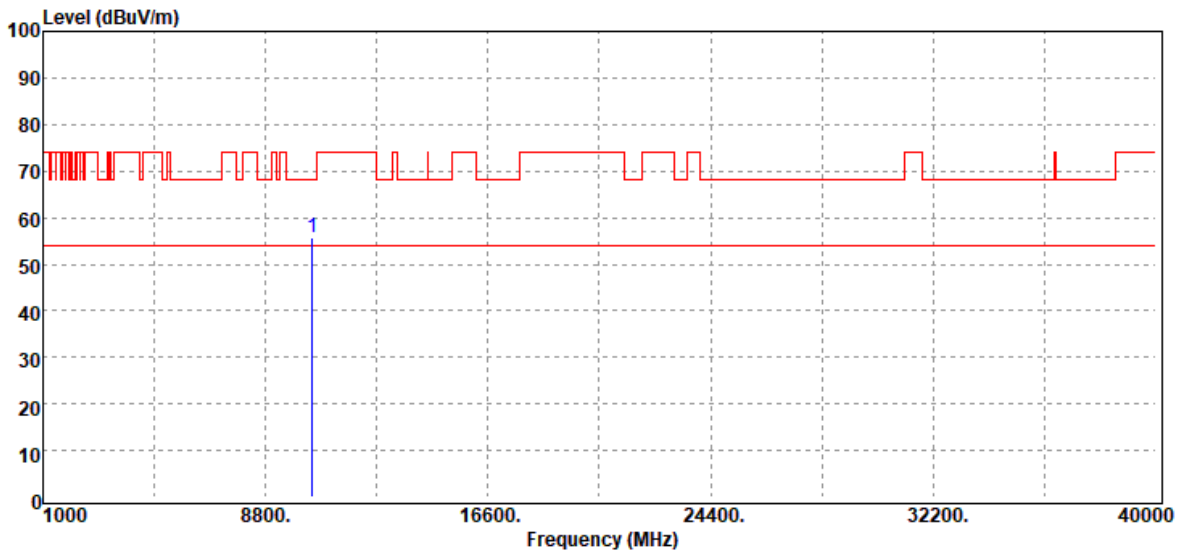

Frequency (MHz)	Reading (dBuV)	Correct Factor (dB/m)	Result (dBuV/m)	Limit (dBuV/m)	Margin (dB)	Remark
10440.00	40.37	15.21	55.58	68.20	-12.62	Peak
N/A						

Remark:

1. Measuring frequencies from 1 GHz to the 10th harmonic of highest fundamental frequency.
2. For above 1GHz, the EUT peak value was under average limit, therefore the Average value compliance with the average limit

Test Mode	IEEE 802.11a / 5220 MHz	Temp/Hum	28.2(°C)/ 50%RH
Test Item	Harmonic	Test Date	July 12, 2019
Polarize	Horizontal	Test Engineer	Dally Hong
Detector	Peak		

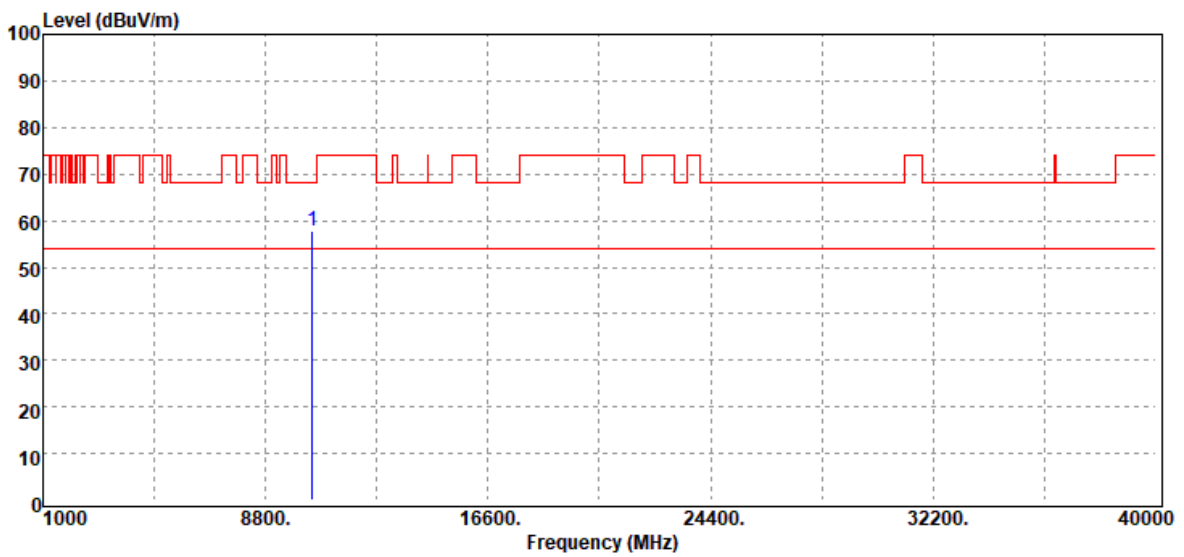

Frequency (MHz)	Reading (dBuV)	Correct Factor (dB/m)	Result (dBuV/m)	Limit (dBuV/m)	Margin (dB)	Remark
10440.00	42.67	15.21	57.88	68.20	-10.32	Peak
N/A						

Remark:

1. Measuring frequencies from 1 GHz to the 10th harmonic of highest fundamental frequency.
2. For above 1GHz, the EUT peak value was under average limit, therefore the Average value compliance with the average limit

Test Mode	IEEE 802.11a / 5240MHZ	Temp/Hum	28.2(°C)/ 50%RH
Test Item	Harmonic	Test Date	July 12, 2019
Polarize	Vertical	Test Engineer	Dally Hong
Detector	Peak		

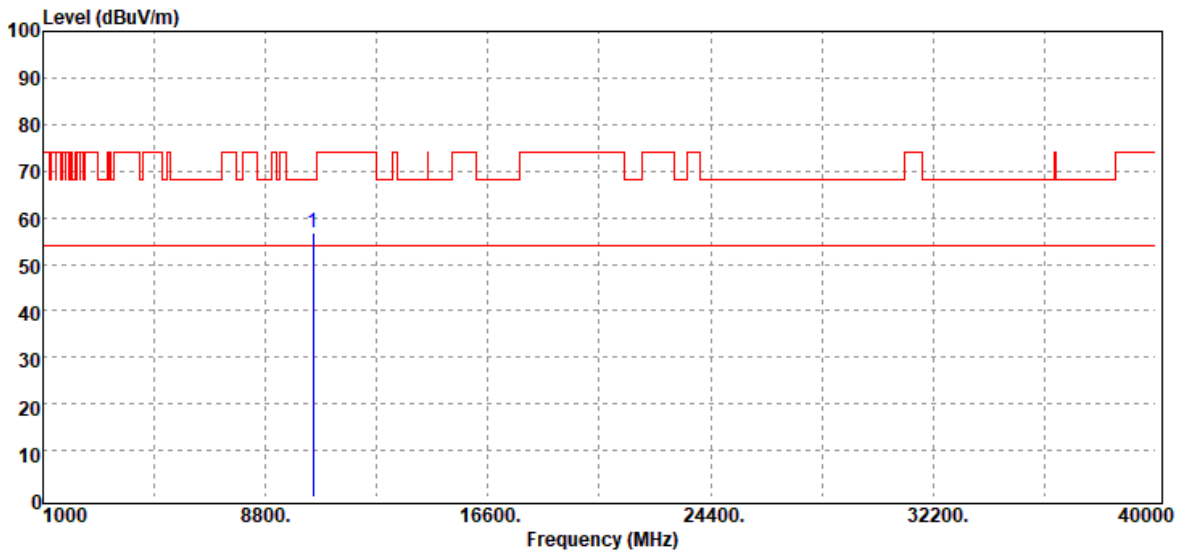

Frequency (MHz)	Reading (dBuV)	Correct Factor (dB/m)	Result (dBuV/m)	Limit (dBuV/m)	Margin (dB)	Remark
10480.00	40.73	16.09	56.82	68.20	-11.38	Peak
N/A						

Remark:

1. Measuring frequencies from 1 GHz to the 10th harmonic of highest fundamental frequency.
2. For above 1GHz, the EUT peak value was under average limit, therefore the Average value compliance with the average limit

Test Mode	IEEE 802.11a / 5240MHZ	Temp/Hum	28.2(°C)/ 50%RH
Test Item	Harmonic	Test Date	July 12, 2019
Polarize	Horizontal	Test Engineer	Dally Hong
Detector	Peak		

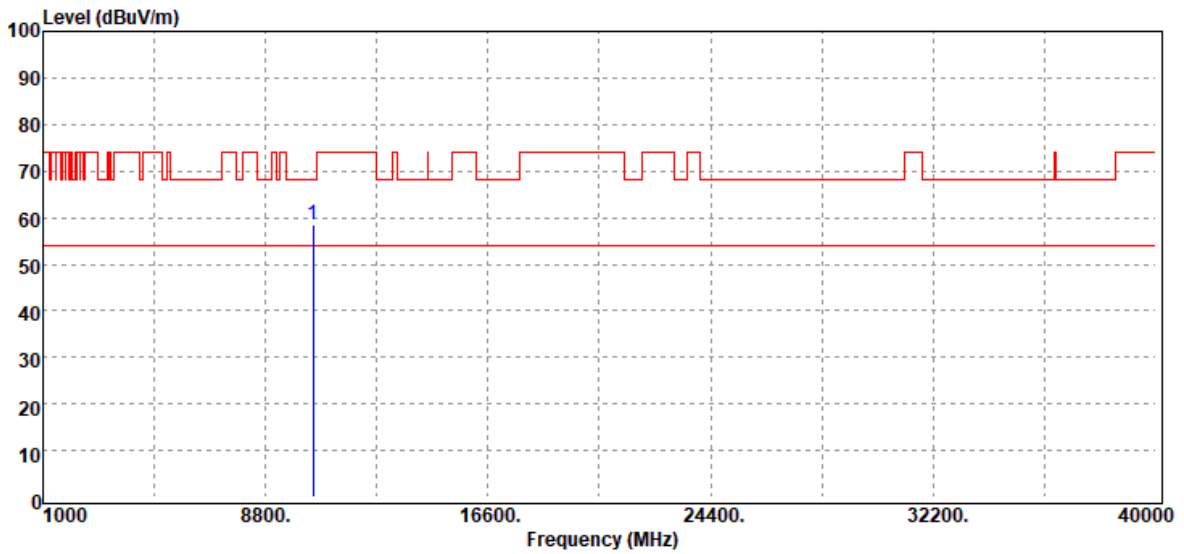

Frequency (MHz)	Reading (dBuV)	Correct Factor (dB/m)	Result (dBuV/m)	Limit (dBuV/m)	Margin (dB)	Remark
10480.00	42.39	16.09	58.48	68.20	-9.72	Peak
N/A						

Remark:

1. Measuring frequencies from 1 GHz to the 10th harmonic of highest fundamental frequency.
2. For above 1GHz, the EUT peak value was under average limit, therefore the Average value compliance with the average limit

Report No.: T190315W01-RP4

Test Mode	IEEE 802.11n 20 MHz / 5180MHz	Temp/Hum	28.2(°C)/ 50%RH
Test Item	Harmonic	Test Date	July 12, 2019
Polarize	Vertical	Test Engineer	Dally Hong
Detector	Peak		

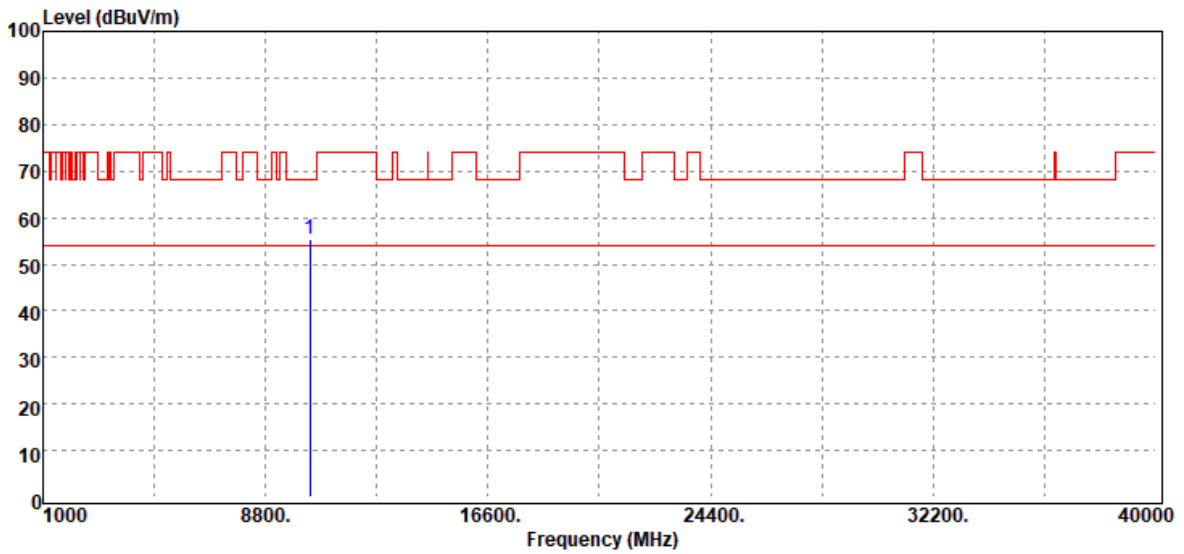

Frequency (MHz)	Reading (dBuV)	Correct Factor (dB/m)	Result (dBuV/m)	Limit (dBuV/m)	Margin (dB)	Remark
10360.00	41.23	14.12	55.35	68.20	-12.85	Peak
N/A						

Remark:

1. Measuring frequencies from 1 GHz to the 10th harmonic of highest fundamental frequency.
2. For above 1GHz, the EUT peak value was under average limit, therefore the Average value compliance with the average limit



Report No.: T190315W01-RP4

Test Mode	IEEE 802.11n 20 MHz/ 5180MHz	Temp/Hum	28.2(°C)/ 50%RH
Test Item	Harmonic	Test Date	July 12, 2019
Polarize	Horizontal	Test Engineer	Dally Hong
Detector	Peak		

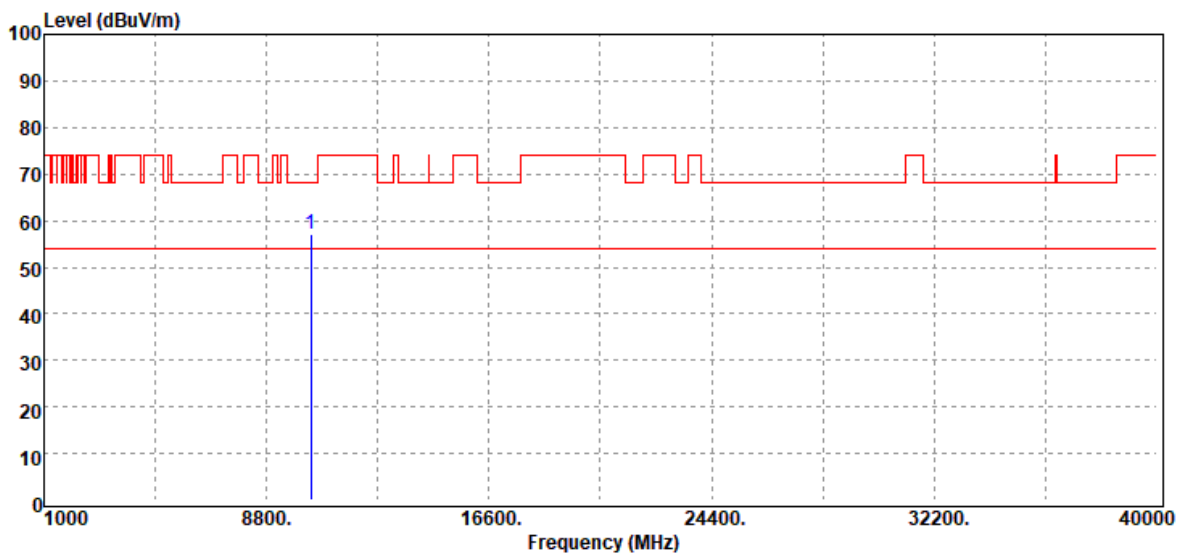

Frequency (MHz)	Reading (dBuV)	Correct Factor (dB/m)	Result (dBuV/m)	Limit (dBuV/m)	Margin (dB)	Remark
10360.00	43.09	14.12	57.21	68.20	-10.99	Peak
N/A						

Remark:

1. Measuring frequencies from 1 GHz to the 10th harmonic of highest fundamental frequency.
2. For above 1GHz, the EUT peak value was under average limit, therefore the Average value compliance with the average limit

Report No.: T190315W01-RP4

Test Mode	IEEE 802.11n 20 MHz / 5220MHz	Temp/Hum	28.2(°C)/ 50%RH
Test Item	Harmonic	Test Date	July 12, 2019
Polarize	Vertical	Test Engineer	Dally Hong
Detector	Peak		

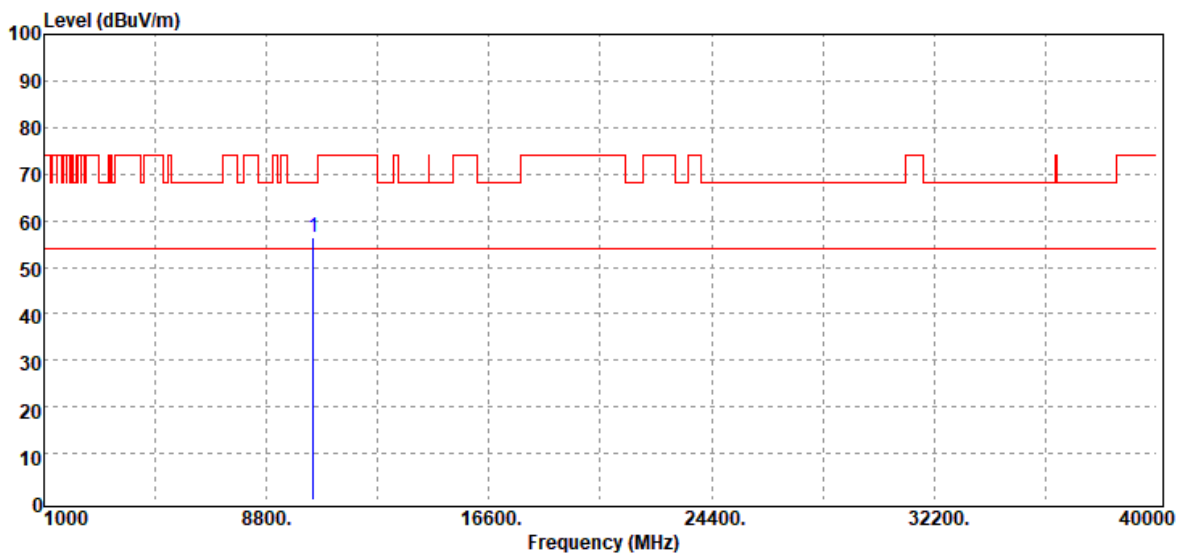

Frequency (MHz)	Reading (dBuV)	Correct Factor (dB/m)	Result (dBuV/m)	Limit (dBuV/m)	Margin (dB)	Remark
10440.00	41.10	15.21	56.31	68.20	-11.89	Peak
N/A						

Remark:

1. Measuring frequencies from 1 GHz to the 10th harmonic of highest fundamental frequency.
2. For above 1GHz, the EUT peak value was under average limit, therefore the Average value compliance with the average limit

Test Mode	IEEE 802.11n 20 MHz / 5220MHZ	Temp/Hum	28.2(°C)/ 50%RH
Test Item	Harmonic	Test Date	July 12, 2019
Polarize	Horizontal	Test Engineer	Dally Hong
Detector	Peak		

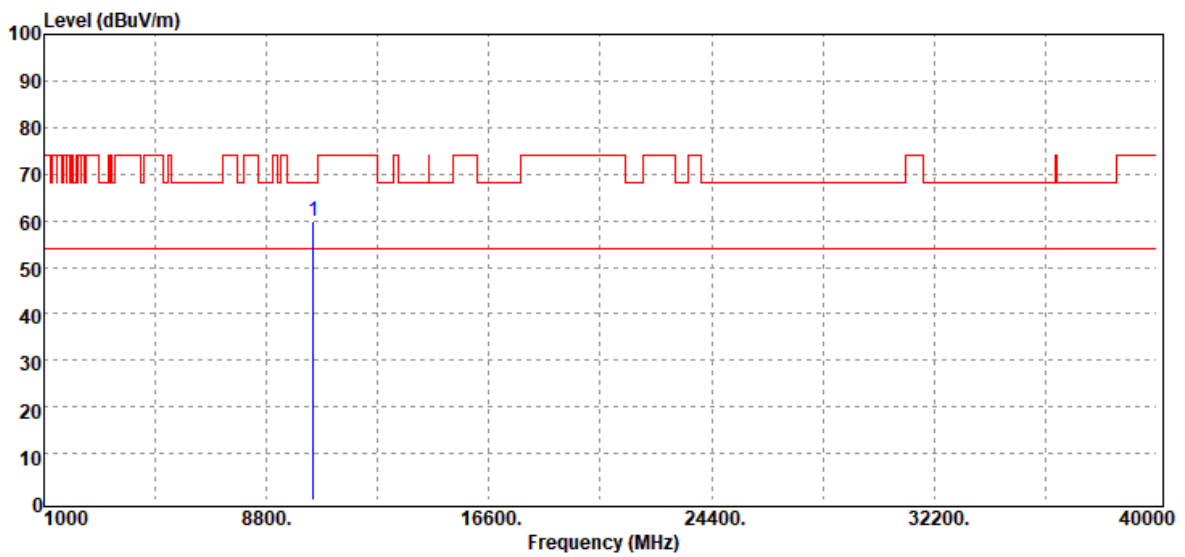

Frequency (MHz)	Reading (dBuV)	Correct Factor (dB/m)	Result (dBuV/m)	Limit (dBuV/m)	Margin (dB)	Remark
10440.00	44.52	15.21	59.73	68.20	-8.47	Peak
N/A						

Remark:

1. Measuring frequencies from 1 GHz to the 10th harmonic of highest fundamental frequency.
2. For above 1GHz, the EUT peak value was under average limit, therefore the Average value compliance with the average limit

Report No.: T190315W01-RP4

Test Mode	IEEE 802.11n 20 MHz / 5240MHZ	Temp/Hum	28.2(°C)/ 50%RH
Test Item	Harmonic	Test Date	July 12, 2019
Polarize	Vertical	Test Engineer	Dally Hong
Detector	Peak		

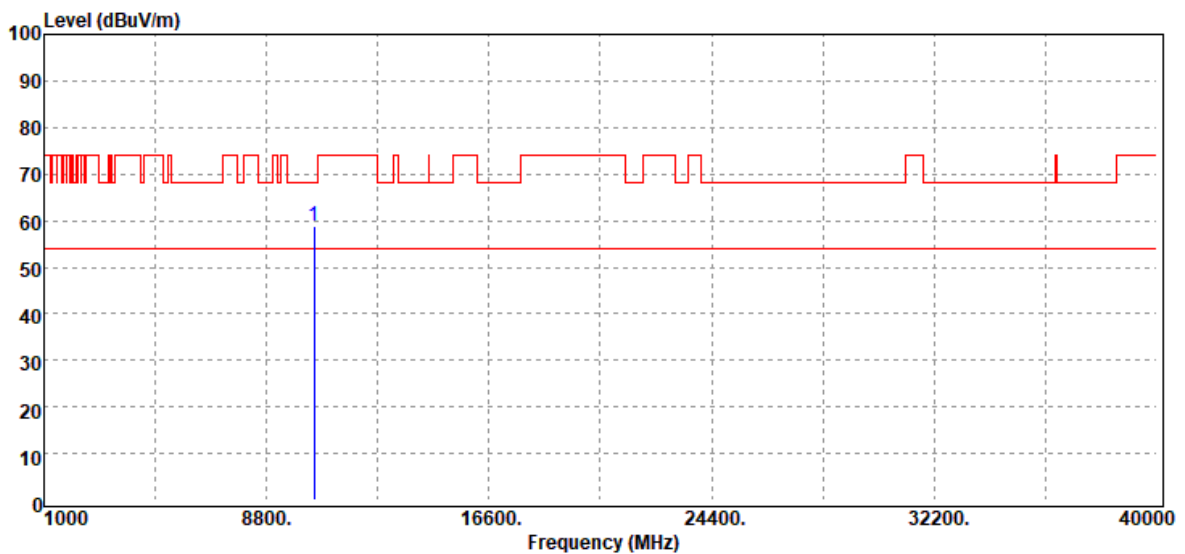

Frequency (MHz)	Reading (dBuV)	Correct Factor (dB/m)	Result (dBuV/m)	Limit (dBuV/m)	Margin (dB)	Remark
10480.00	42.85	16.09	58.94	68.20	-9.26	Peak
N/A						

Remark:

1. Measuring frequencies from 1 GHz to the 10th harmonic of highest fundamental frequency.
2. For above 1GHz, the EUT peak value was under average limit, therefore the Average value compliance with the average limit

Test Mode	IEEE 802.11n 20 MHz / 5240MHz	Temp/Hum	28.2(°C)/ 50%RH
Test Item	Harmonic	Test Date	July 12, 2019
Polarize	Horizontal	Test Engineer	Dally Hong
Detector	Peak		

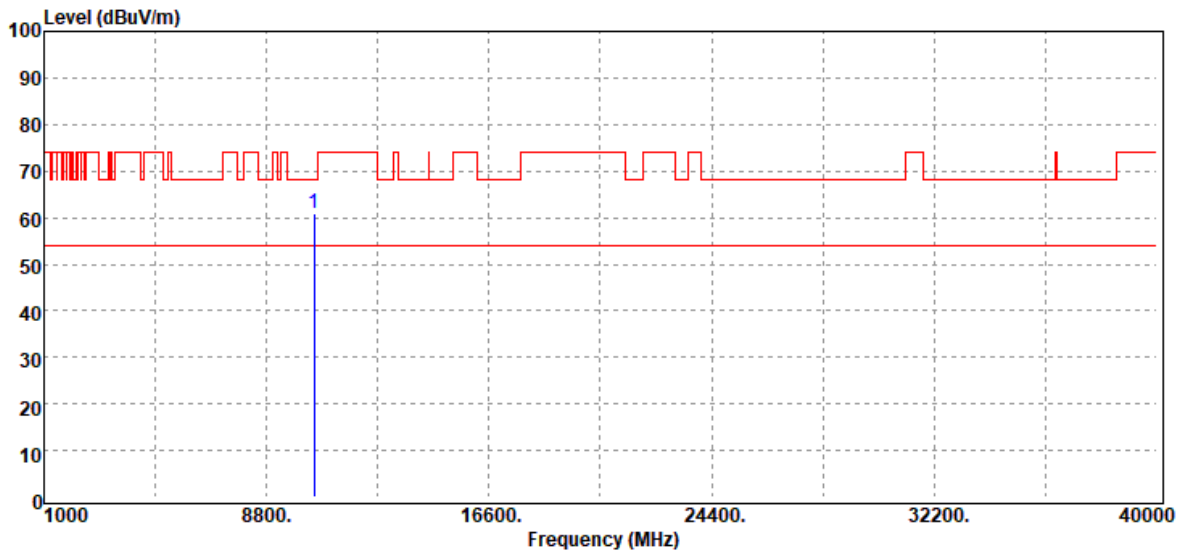

Frequency (MHz)	Reading (dBuV)	Correct Factor (dB/m)	Result (dBuV/m)	Limit (dBuV/m)	Margin (dB)	Remark
10480.00	44.83	16.09	60.92	68.20	-7.28	Peak
N/A						

Remark:

1. Measuring frequencies from 1 GHz to the 10th harmonic of highest fundamental frequency.
2. For above 1GHz, the EUT peak value was under average limit, therefore the Average value compliance with the average limit

Report No.: T190315W01-RP4

Test Mode	IEEE 802.11n 40 MHz / 5190MHz	Temp/Hum	28.2(°C)/ 50%RH
Test Item	Harmonic	Test Date	July 12, 2019
Polarize	Vertical	Test Engineer	Dally Hong
Detector	Peak		

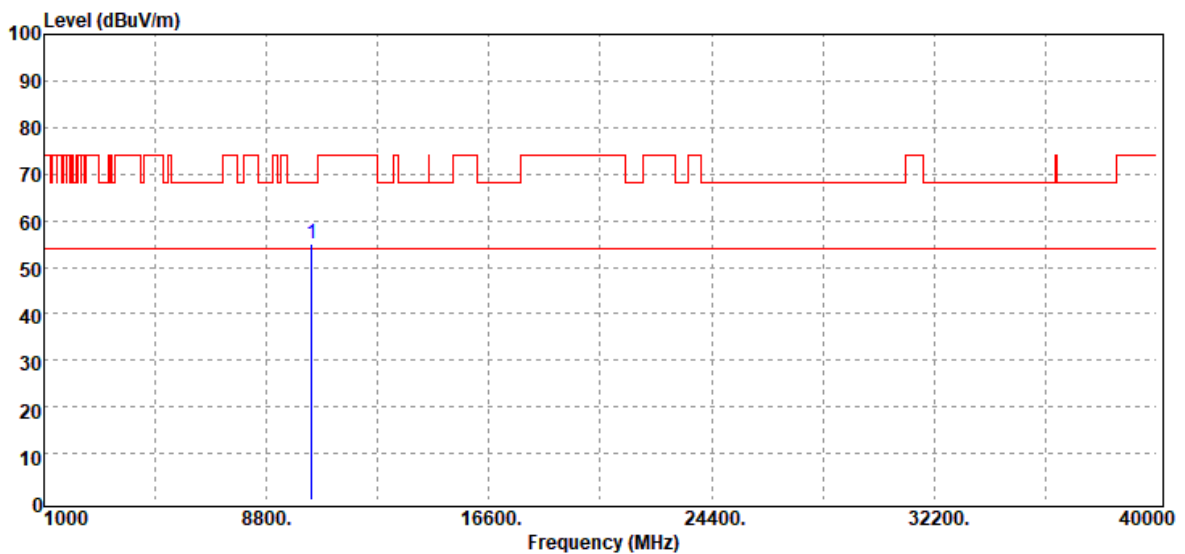

Frequency (MHz)	Reading (dBuV)	Correct Factor (dB/m)	Result (dBuV/m)	Limit (dBuV/m)	Margin (dB)	Remark
10380.00	40.71	14.23	54.94	68.20	-13.26	Peak
N/A						

Remark:

1. Measuring frequencies from 1 GHz to the 10th harmonic of highest fundamental frequency.
2. For above 1GHz, the EUT peak value was under average limit, therefore the Average value compliance with the average limit

Test Mode	IEEE 802.11n 40 MHz / 5190MHz	Temp/Hum	28.2(°C)/ 50%RH
Test Item	Harmonic	Test Date	July 12, 2019
Polarize	Horizontal	Test Engineer	Dally Hong
Detector	Peak		

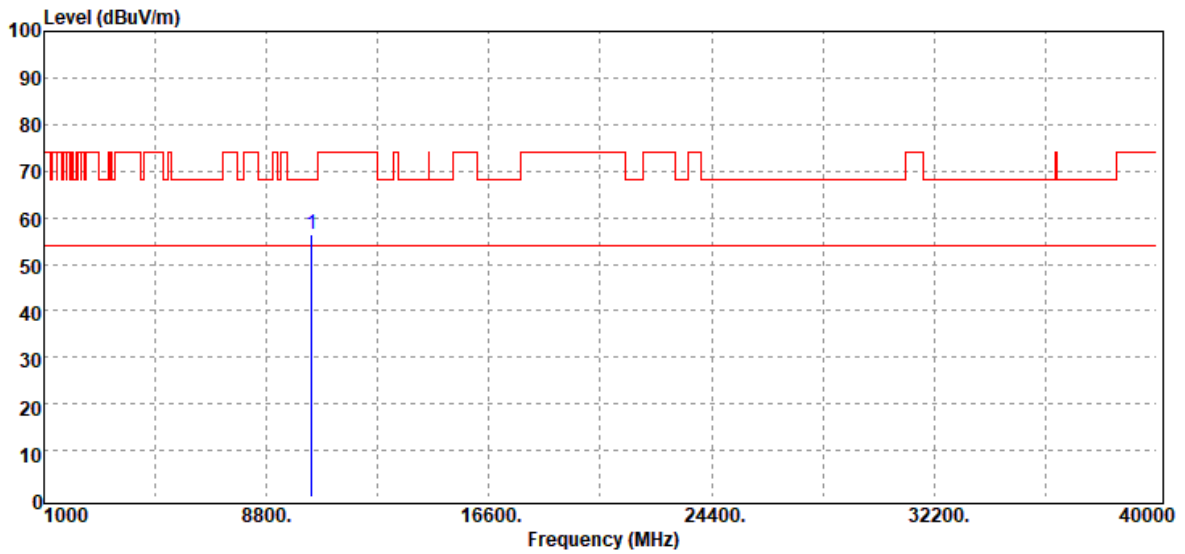

Frequency (MHz)	Reading (dBuV)	Correct Factor (dB/m)	Result (dBuV/m)	Limit (dBuV/m)	Margin (dB)	Remark
10380.00	42.13	14.23	56.36	68.20	-11.84	Peak
N/A						

Remark:

1. Measuring frequencies from 1 GHz to the 10th harmonic of highest fundamental frequency.
2. For above 1GHz, the EUT peak value was under average limit, therefore the Average value compliance with the average limit

Report No.: T190315W01-RP4

Test Mode	IEEE 802.11n 40 MHz / 5230MHz	Temp/Hum	28.2(°C)/ 50%RH
Test Item	Harmonic	Test Date	July 12, 2019
Polarize	Vertical	Test Engineer	Dally Hong
Detector	Peak		

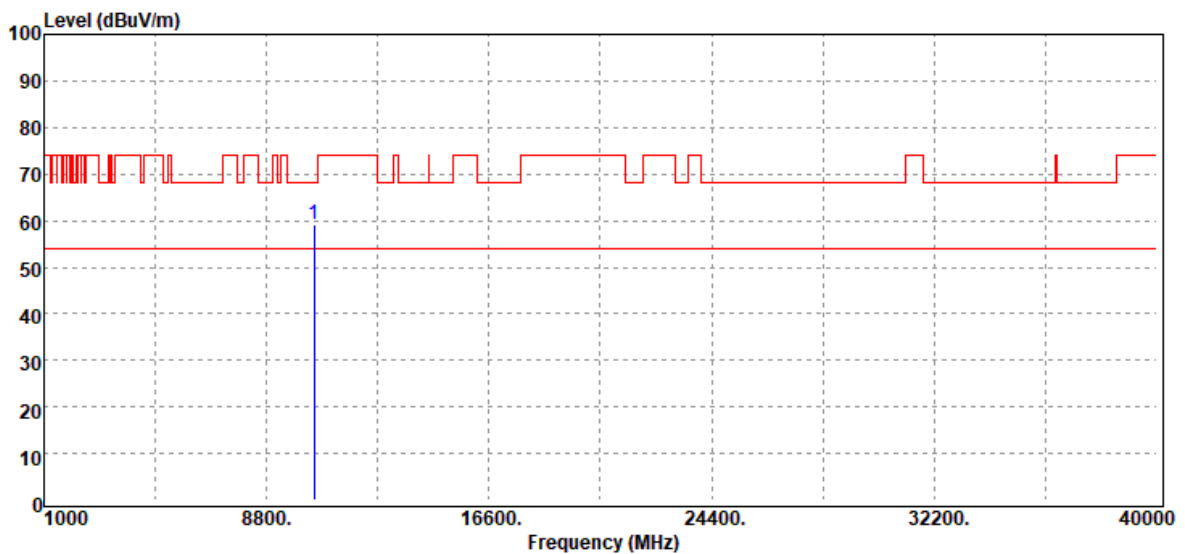

Frequency (MHz)	Reading (dBuV)	Correct Factor (dB/m)	Result (dBuV/m)	Limit (dBuV/m)	Margin (dB)	Remark
10460.00	43.51	15.65	59.16	68.20	-9.04	Peak
N/A						

Remark:

1. Measuring frequencies from 1 GHz to the 10th harmonic of highest fundamental frequency.
2. For above 1GHz, the EUT peak value was under average limit, therefore the Average value compliance with the average limit

Report No.: T190315W01-RP4

Test Mode	IEEE 802.11n 40 MHz / 5230MHz	Temp/Hum	28.2(°C)/ 50%RH
Test Item	Harmonic	Test Date	July 12, 2019
Polarize	Horizontal	Test Engineer	Dally Hong
Detector	Peak		

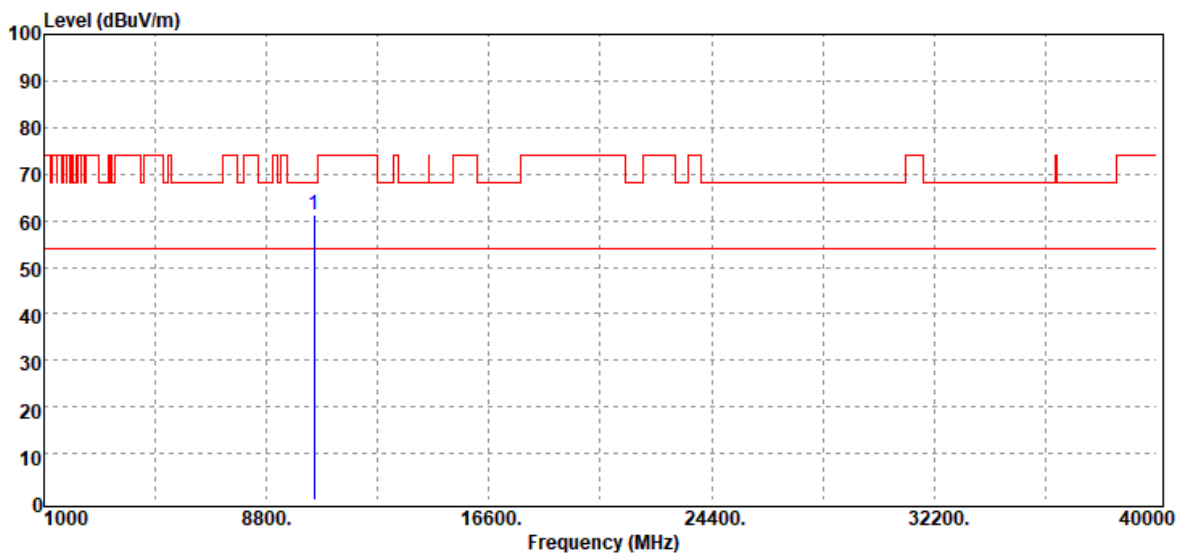

Frequency (MHz)	Reading (dBuV)	Correct Factor (dB/m)	Result (dBuV/m)	Limit (dBuV/m)	Margin (dB)	Remark
10460.00	45.69	15.65	61.34	68.20	-6.86	Peak
N/A						

Remark:

1. Measuring frequencies from 1 GHz to the 10th harmonic of highest fundamental frequency.
2. For above 1GHz, the EUT peak value was under average limit, therefore the Average value compliance with the average limit



Report No.: T190315W01-RP4

Page: 119 / 192
Rev.: 01

Test Mode	IEEE 802.11ac VHT80 / 5210MHZ	Temp/Hum	28.2(°C)/ 50%RH
Test Item	Harmonic	Test Date	July 12, 2019
Polarize	Vertical	Test Engineer	Dally Hong
Detector	Peak		

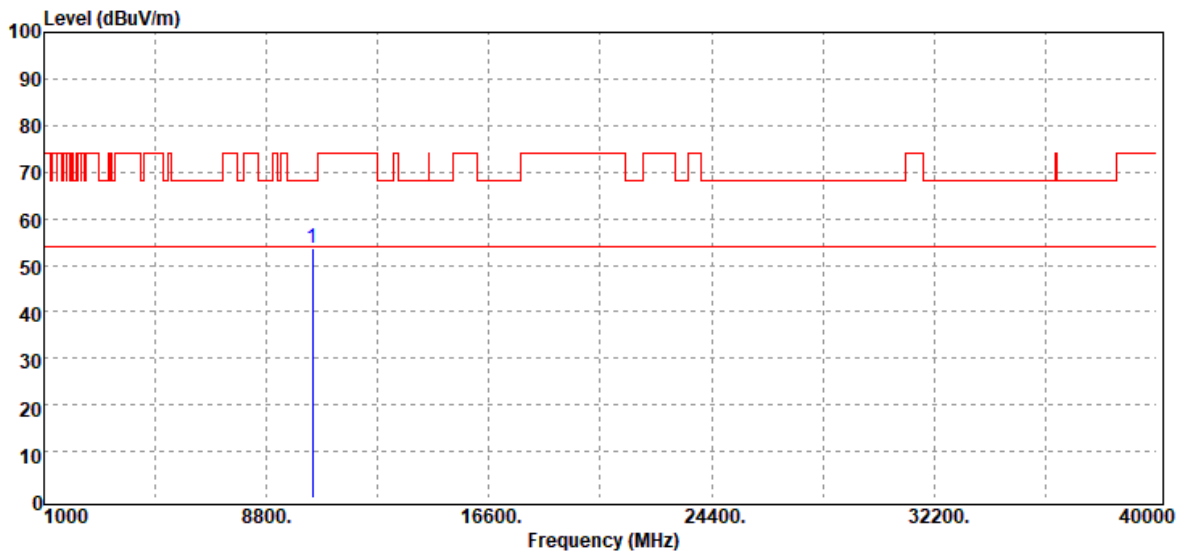

Frequency (MHz)	Reading (dBuV)	Correct Factor (dB/m)	Result (dBuV/m)	Limit (dBuV/m)	Margin (dB)	Remark
10420.00	38.71	14.78	53.49	68.20	-14.71	Peak
N/A						

Remark:

1. Measuring frequencies from 1 GHz to the 10th harmonic of highest fundamental frequency.
2. For above 1GHz, the EUT peak value was under average limit, therefore the Average value compliance with the average limit

Test Mode	IEEE 802.11ac VHT80 / 5210MHZ	Temp/Hum	28.2(°C)/ 50%RH
Test Item	Harmonic	Test Date	July 12, 2019
Polarize	Horizontal	Test Engineer	Dally Hong
Detector	Peak		

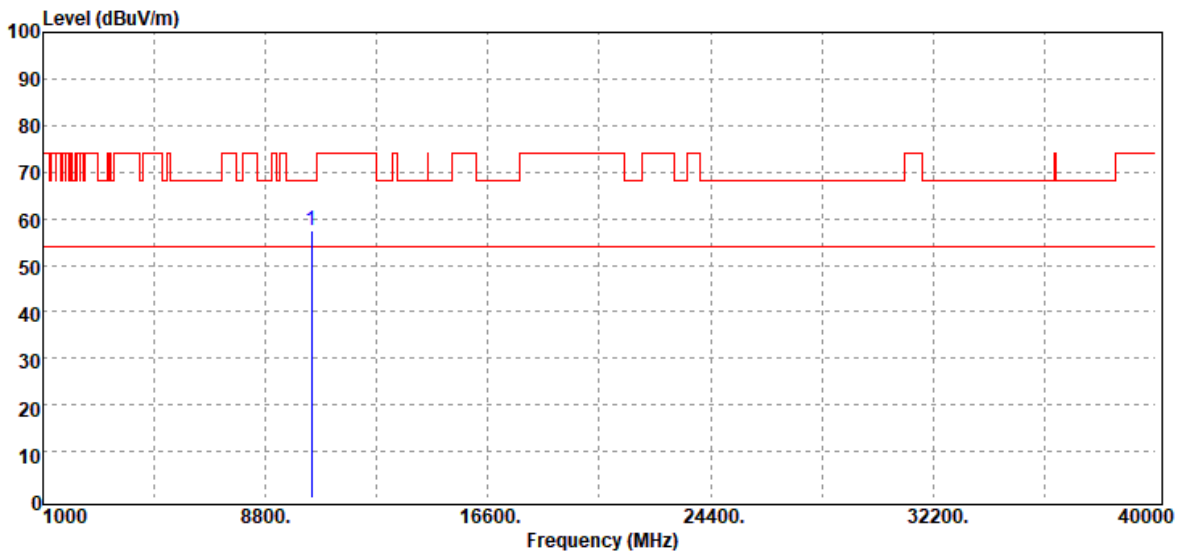

Frequency (MHz)	Reading (dBuV)	Correct Factor (dB/m)	Result (dBuV/m)	Limit (dBuV/m)	Margin (dB)	Remark
10420.00	42.64	14.78	57.42	68.20	-10.78	Peak
N/A						

Remark:

1. Measuring frequencies from 1 GHz to the 10th harmonic of highest fundamental frequency.
2. For above 1GHz, the EUT peak value was under average limit, therefore the Average value compliance with the average limit

Report No.: T190315W01-RP4

Above 1G Test Data for UNII-2a

Test Mode	IEEE 802.11a / 5260 MHz	Temp/Hum	28.2(°C)/ 50%RH
Test Item	Harmonic	Test Date	July 12, 2019
Polarize	Vertical	Test Engineer	Dally Hong
Detector	Peak		

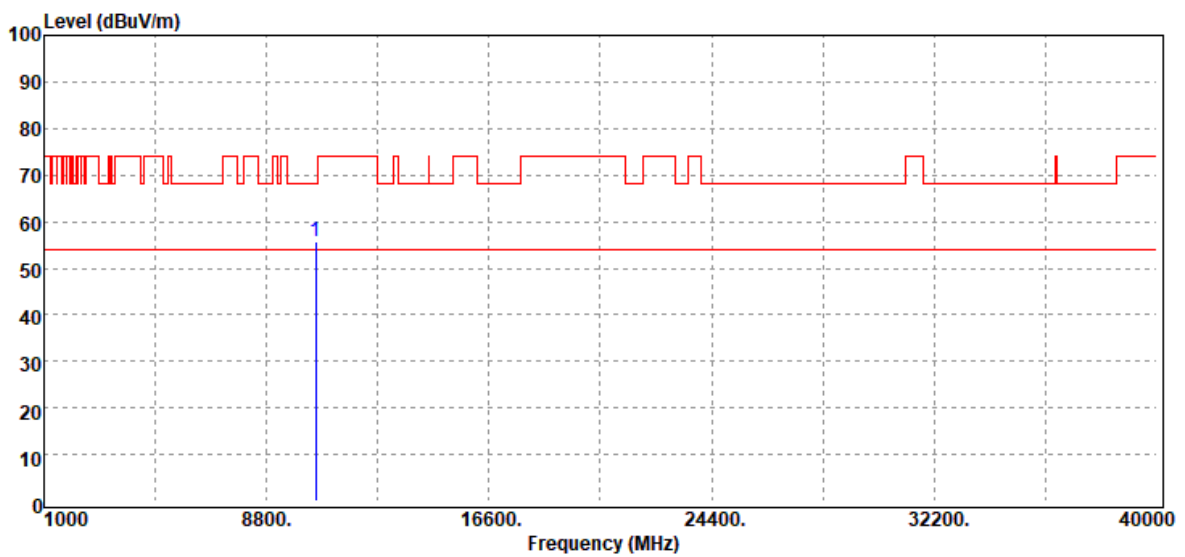

Frequency (MHz)	Reading (dBuV)	Correct Factor (dB/m)	Result (dBuV/m)	Limit (dBuV/m)	Margin (dB)	Remark
10520.00	40.32	15.33	55.65	68.20	-12.55	Peak
N/A						

Remark:

1. Measuring frequencies from 1 GHz to the 10th harmonic of highest fundamental frequency.
2. For above 1GHz, the EUT peak value was under average limit, therefore the Average value compliance with the average limit

Test Mode	IEEE 802.11a / 5260 MHz	Temp/Hum	28.2(°C)/ 50%RH
Test Item	Harmonic	Test Date	July 12, 2019
Polarize	Horizontal	Test Engineer	Dally Hong
Detector	Peak		

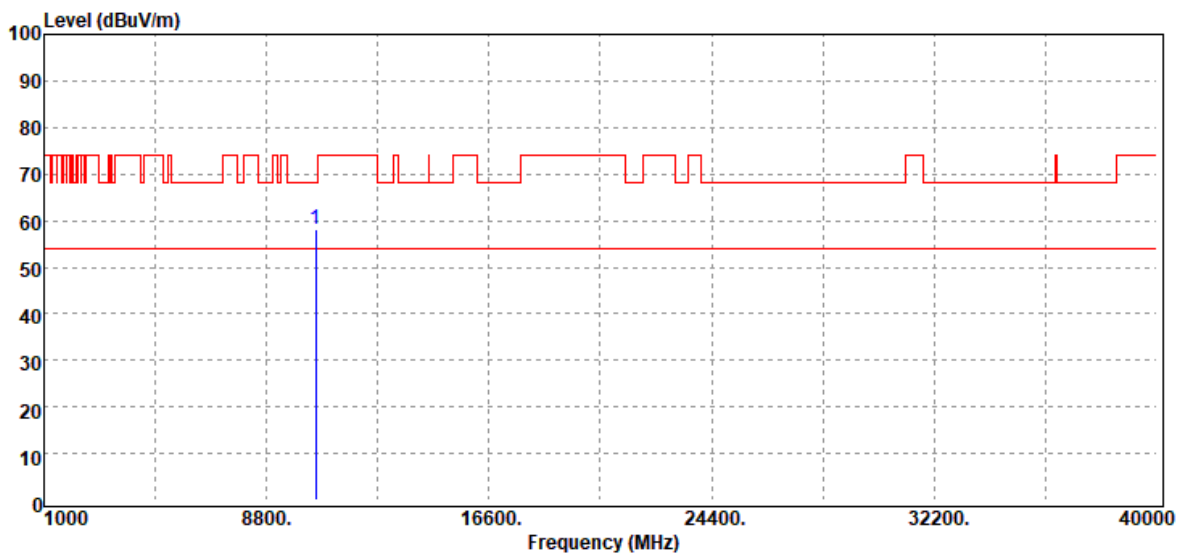

Frequency (MHz)	Reading (dBuV)	Correct Factor (dB/m)	Result (dBuV/m)	Limit (dBuV/m)	Margin (dB)	Remark
10520.00	42.71	15.33	58.04	68.20	-10.16	Peak
N/A						

Remark:

1. Measuring frequencies from 1 GHz to the 10th harmonic of highest fundamental frequency.
2. For above 1GHz, the EUT peak value was under average limit, therefore the Average value compliance with the average limit

Test Mode	IEEE 802.11a / 5280 MHz	Temp/Hum	28.2(°C)/ 50%RH
Test Item	Harmonic	Test Date	July 12, 2019
Polarize	Vertical	Test Engineer	Dally Hong
Detector	Peak		

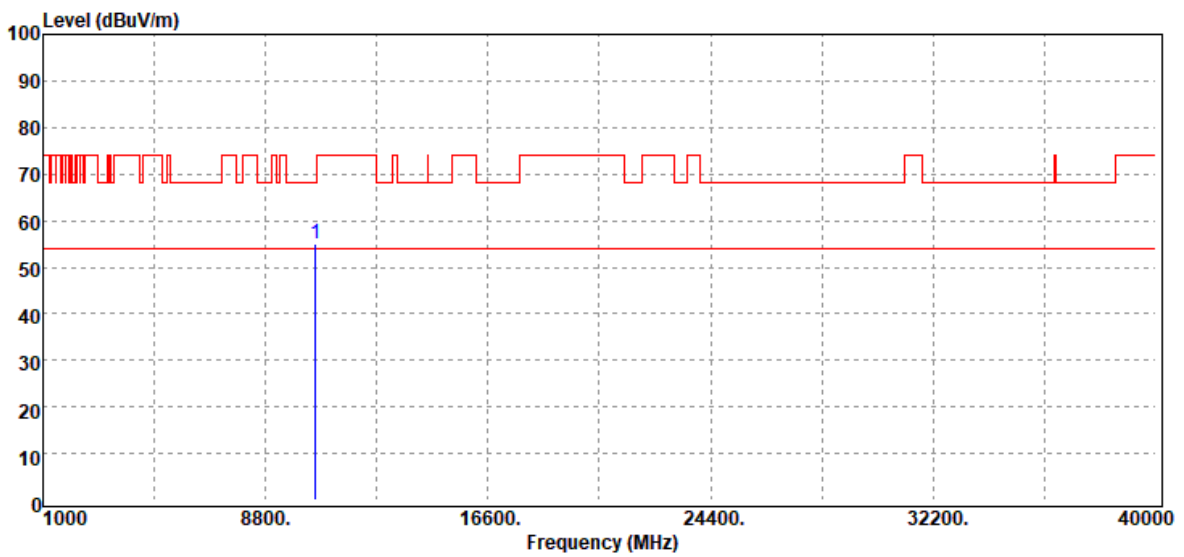

Frequency (MHz)	Reading (dBuV)	Correct Factor (dB/m)	Result (dBuV/m)	Limit (dBuV/m)	Margin (dB)	Remark
10560.00	40.51	14.58	55.09	68.20	-13.11	Peak
N/A						

Remark:

1. Measuring frequencies from 1 GHz to the 10th harmonic of highest fundamental frequency.
2. For above 1GHz, the EUT peak value was under average limit, therefore the Average value compliance with the average limit

Test Mode	IEEE 802.11a / 5280 MHz	Temp/Hum	28.2(°C)/ 50%RH
Test Item	Harmonic	Test Date	July 12, 2019
Polarize	Horizontal	Test Engineer	Dally Hong
Detector	Peak		

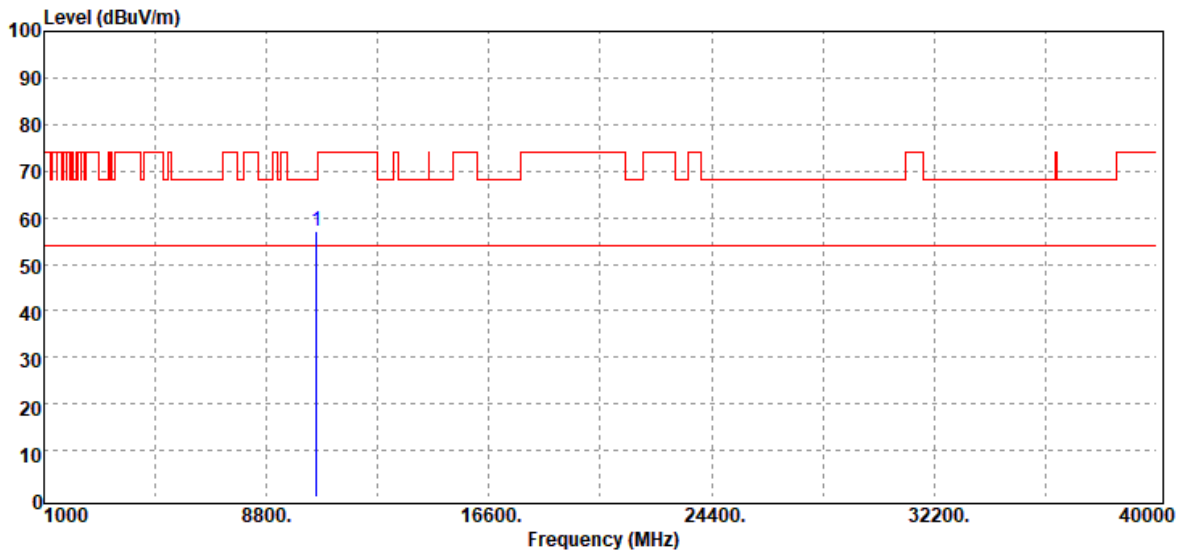

Frequency (MHz)	Reading (dBuV)	Correct Factor (dB/m)	Result (dBuV/m)	Limit (dBuV/m)	Margin (dB)	Remark
10560.00	42.67	14.58	57.25	68.20	-10.95	Peak
N/A						

Remark:

1. Measuring frequencies from 1 GHz to the 10th harmonic of highest fundamental frequency.
2. For above 1GHz, the EUT peak value was under average limit, therefore the Average value compliance with the average limit

Test Mode	IEEE 802.11a / 5320 MHz	Temp/Hum	28.2(°C)/ 50%RH
Test Item	Harmonic	Test Date	July 12, 2019
Polarize	Vertical	Test Engineer	Dally Hong
Detector	Peak and Average		

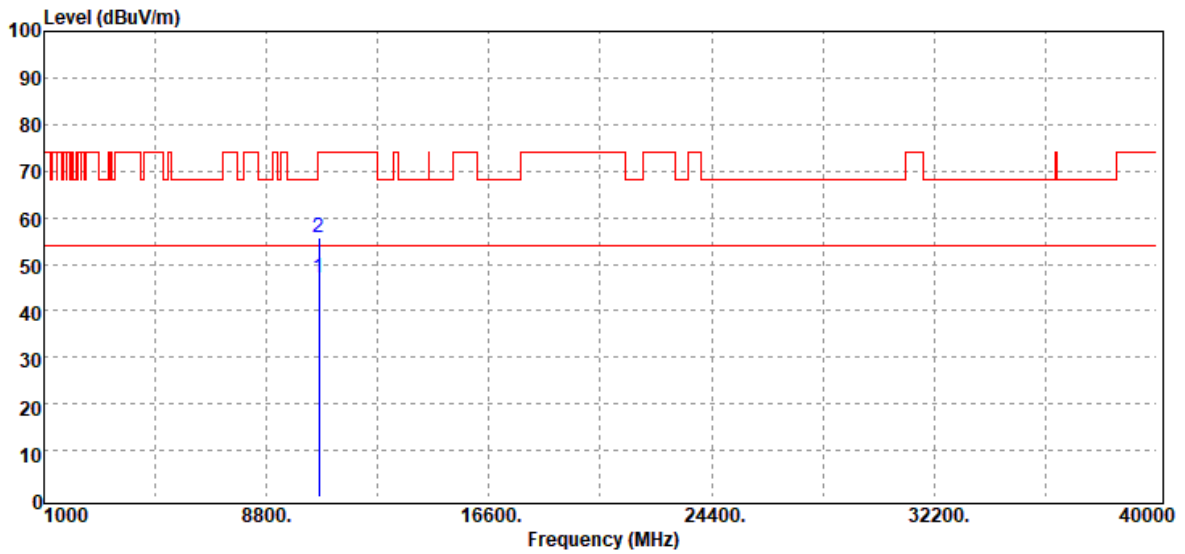

Frequency (MHz)	Reading (dBuV)	Correct Factor (dB/m)	Result (dBuV/m)	Limit (dBuV/m)	Margin (dB)	Remark
10640.00	32.00	15.05	47.05	54.00	-6.95	Average
10640.00	40.67	15.05	55.72	74.00	-18.28	Peak
N/A						

Remark:

- Measuring frequencies from 1 GHz to the 10th harmonic of highest fundamental frequency.

Test Mode	IEEE 802.11a / 5320 MHz	Temp/Hum	28.2(°C)/ 50%RH
Test Item	Harmonic	Test Date	July 12, 2019
Polarize	Horizontal	Test Engineer	Dally Hong
Detector	Peak and Average		

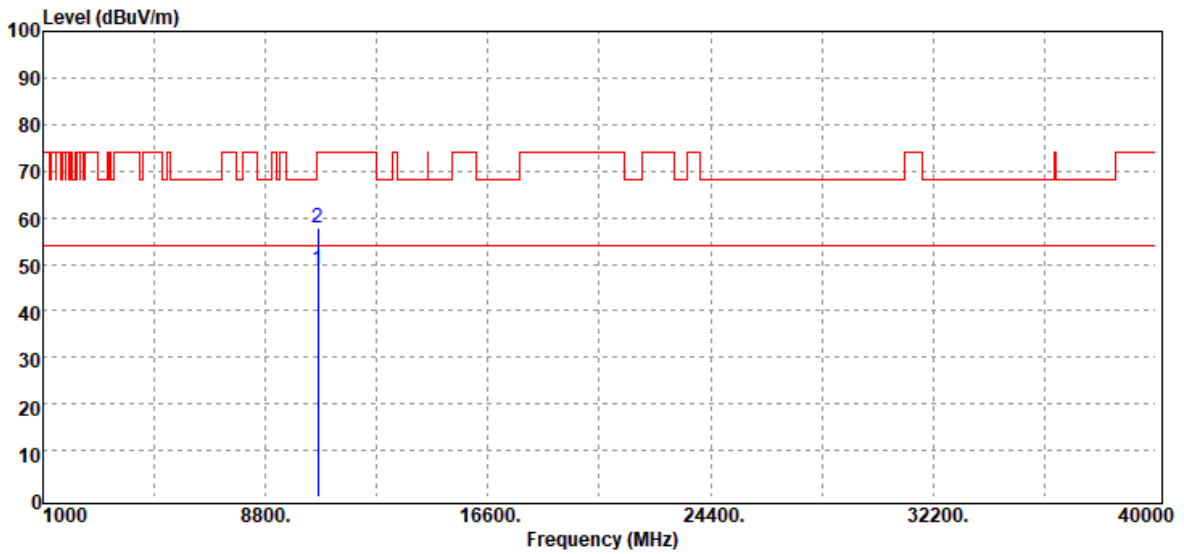

Frequency (MHz)	Reading (dBuV)	Correct Factor (dB/m)	Result (dBuV/m)	Limit (dBuV/m)	Margin (dB)	Remark
10640.00	33.78	15.05	48.83	54.00	-5.17	Average
10640.00	42.87	15.05	57.92	74.00	-16.08	Peak
N/A						

Remark:

1. Measuring frequencies from 1 GHz to the 10th harmonic of highest fundamental frequency.

Report No.: T190315W01-RP4

Test Mode	IEEE 802.11n 20 MHz / 5260 MHz	Temp/Hum	28.2(°C)/ 50%RH
Test Item	Harmonic	Test Date	July 12, 2019
Polarize	Vertical	Test Engineer	Dally Hong
Detector	Peak		

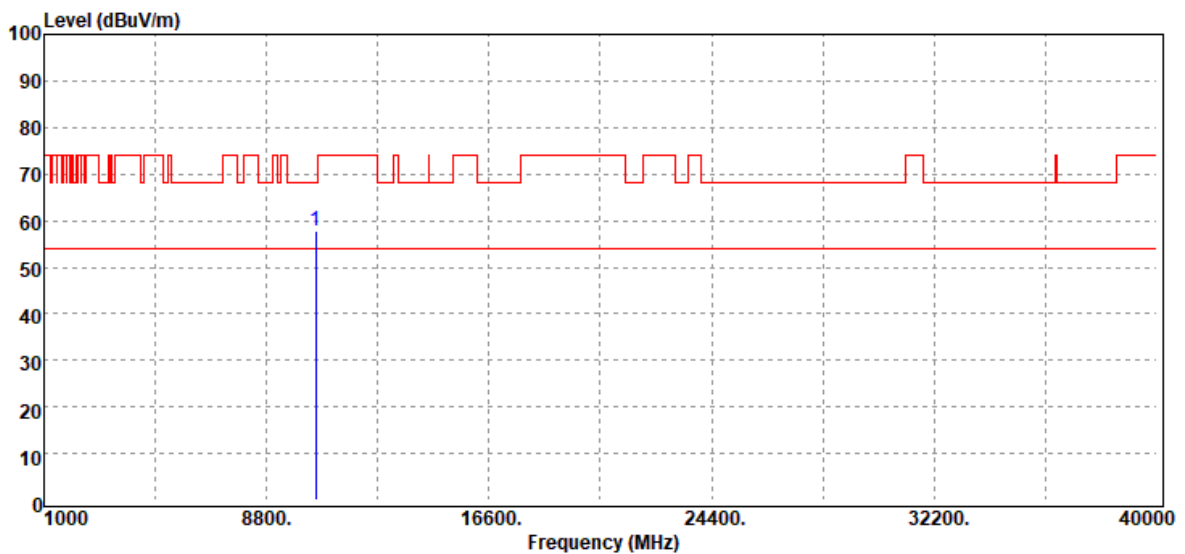

Frequency (MHz)	Reading (dBuV)	Correct Factor (dB/m)	Result (dBuV/m)	Limit (dBuV/m)	Margin (dB)	Remark
10520.00	42.37	15.33	57.70	68.20	-10.50	Peak
N/A						

Remark:

1. Measuring frequencies from 1 GHz to the 10th harmonic of highest fundamental frequency.
2. For above 1GHz, the EUT peak value was under average limit, therefore the Average value compliance with the average limit

Test Mode	IEEE 802.11n 20 MHz / 5260 MHz	Temp/Hum	28.2(°C)/ 50%RH
Test Item	Harmonic	Test Date	July 12, 2019
Polarize	Horizontal	Test Engineer	Dally Hong
Detector	Peak		

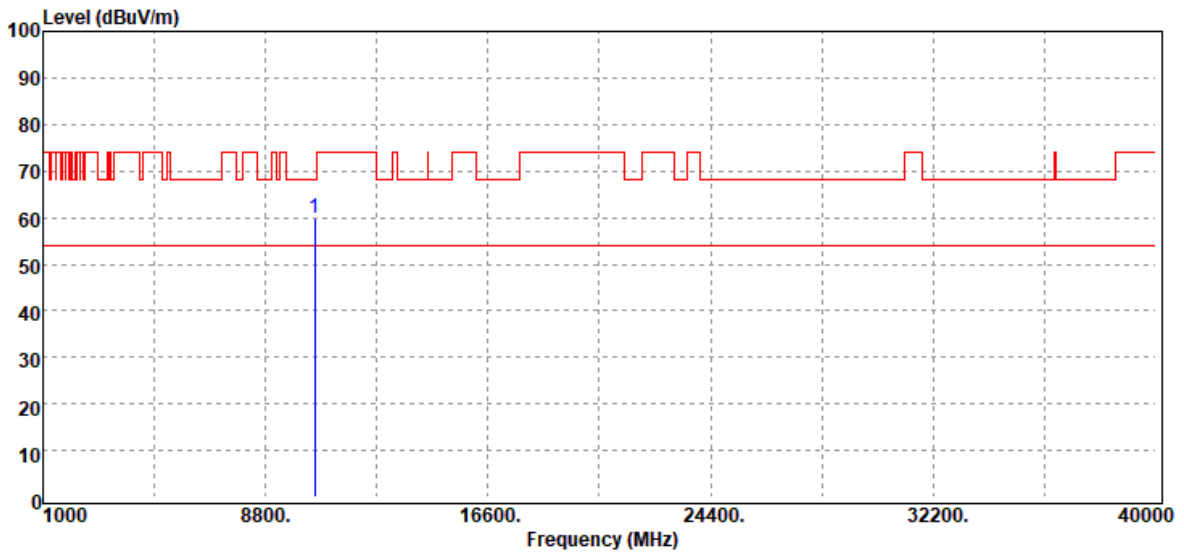

Frequency (MHz)	Reading (dBuV)	Correct Factor (dB/m)	Result (dBuV/m)	Limit (dBuV/m)	Margin (dB)	Remark
10520.00	44.57	15.33	59.90	68.20	-8.30	Peak

Remark:

1. Measuring frequencies from 1 GHz to the 10th harmonic of highest fundamental frequency.
2. For above 1GHz, the EUT peak value was under average limit, therefore the Average value compliance with the average limit

Test Mode	IEEE 802.11n 20 MHz / 5280 MHz	Temp/Hum	28.2(°C)/ 50%RH
Test Item	Harmonic	Test Date	July 12, 2019
Polarize	Vertical	Test Engineer	Dally Hong
Detector	Peak		

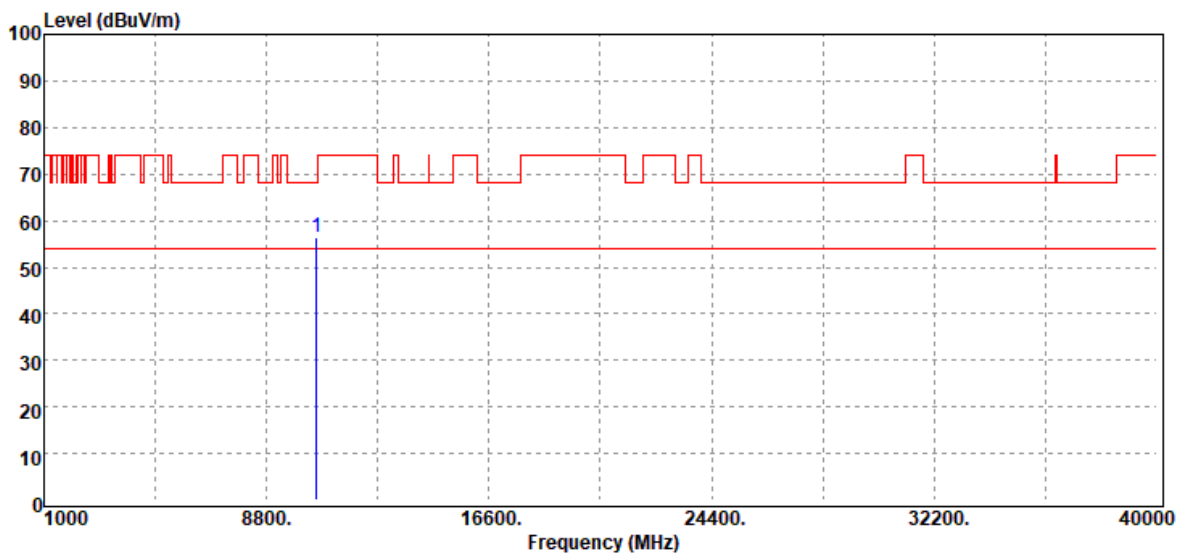

Frequency (MHz)	Reading (dBuV)	Correct Factor (dB/m)	Result (dBuV/m)	Limit (dBuV/m)	Margin (dB)	Remark
10560.00	41.89	14.58	56.47	68.20	-11.73	Peak
N/A						

Remark:

1. Measuring frequencies from 1 GHz to the 10th harmonic of highest fundamental frequency.
2. For above 1GHz, the EUT peak value was under average limit, therefore the Average value compliance with the average limit

Test Mode	IEEE 802.11n 20 MHz / 5280 MHz	Temp/Hum	28.2(°C)/ 50%RH
Test Item	Harmonic	Test Date	July 12, 2019
Polarize	Horizontal	Test Engineer	Dally Hong
Detector	Peak		

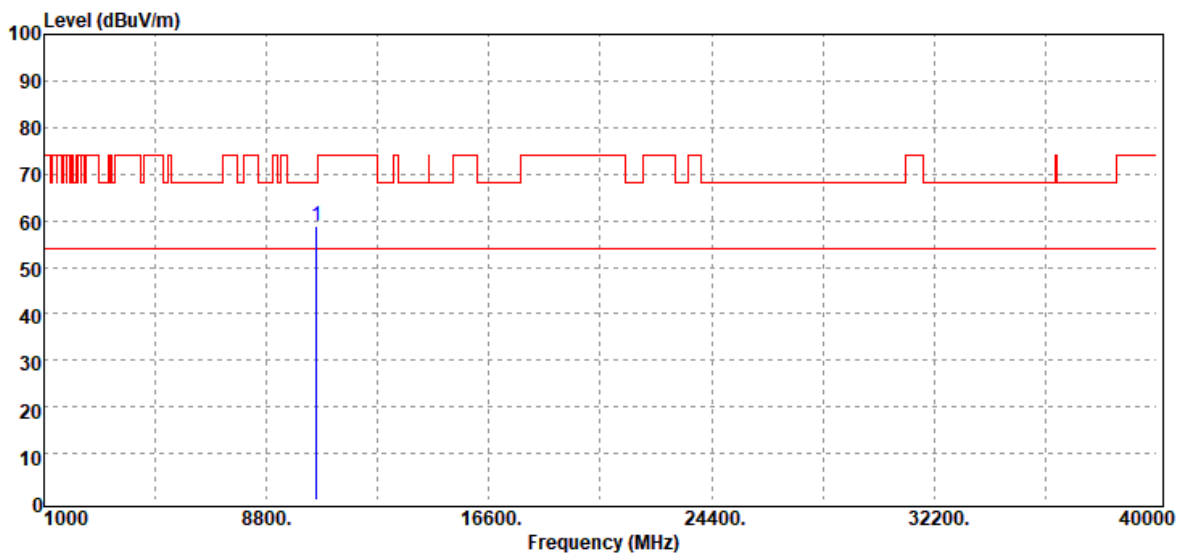

Frequency (MHz)	Reading (dBuV)	Correct Factor (dB/m)	Result (dBuV/m)	Limit (dBuV/m)	Margin (dB)	Remark
10560.00	44.13	14.58	58.71	68.20	-9.49	Peak
N/A						

Remark:

1. Measuring frequencies from 1 GHz to the 10th harmonic of highest fundamental frequency.
2. For above 1GHz, the EUT peak value was under average limit, therefore the Average value compliance with the average limit

Report No.: T190315W01-RP4

Test Mode	IEEE 802.11n 20 MHz / 5320 MHz	Temp/Hum	28.2(°C)/ 50%RH
Test Item	Harmonic	Test Date	July 12, 2019
Polarize	Vertical	Test Engineer	Dally Hong
Detector	Peak and Average		

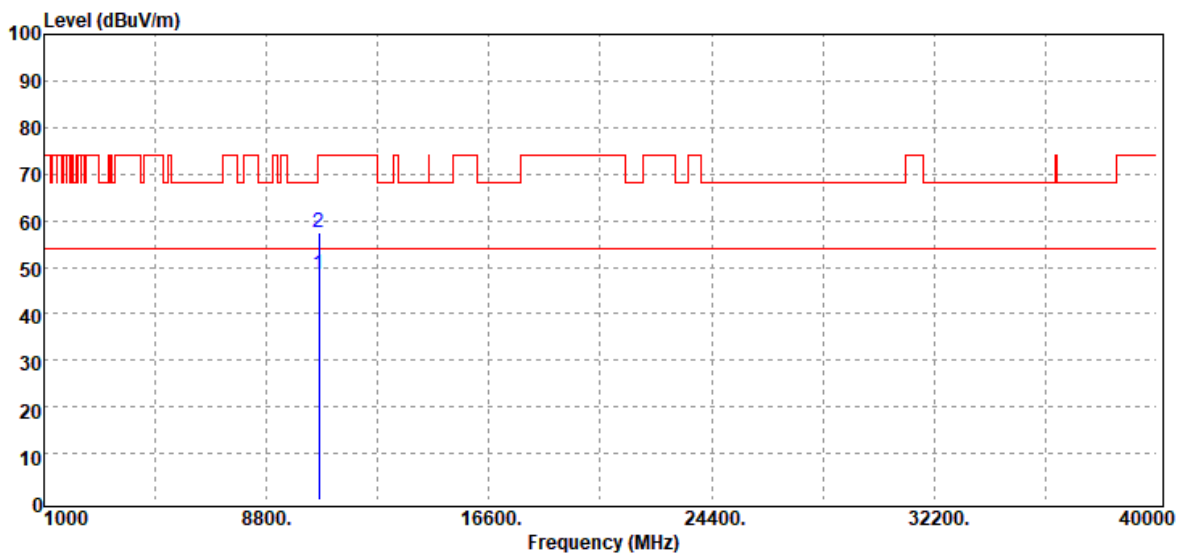

Frequency (MHz)	Reading (dBuV)	Correct Factor (dB/m)	Result (dBuV/m)	Limit (dBuV/m)	Margin (dB)	Remark
10640.00	33.53	15.05	48.58	54.00	-5.42	Average
10640.00	42.50	15.05	57.55	74.00	-16.45	Peak
N/A						

Remark:

- Measuring frequencies from 1 GHz to the 10th harmonic of highest fundamental frequency.

Test Mode	IEEE 802.11n 20 MHz / 5320 MHz	Temp/Hum	28.2(°C)/ 50%RH
Test Item	Harmonic	Test Date	July 12, 2019
Polarize	Horizontal	Test Engineer	Dally Hong
Detector	Peak and Average		

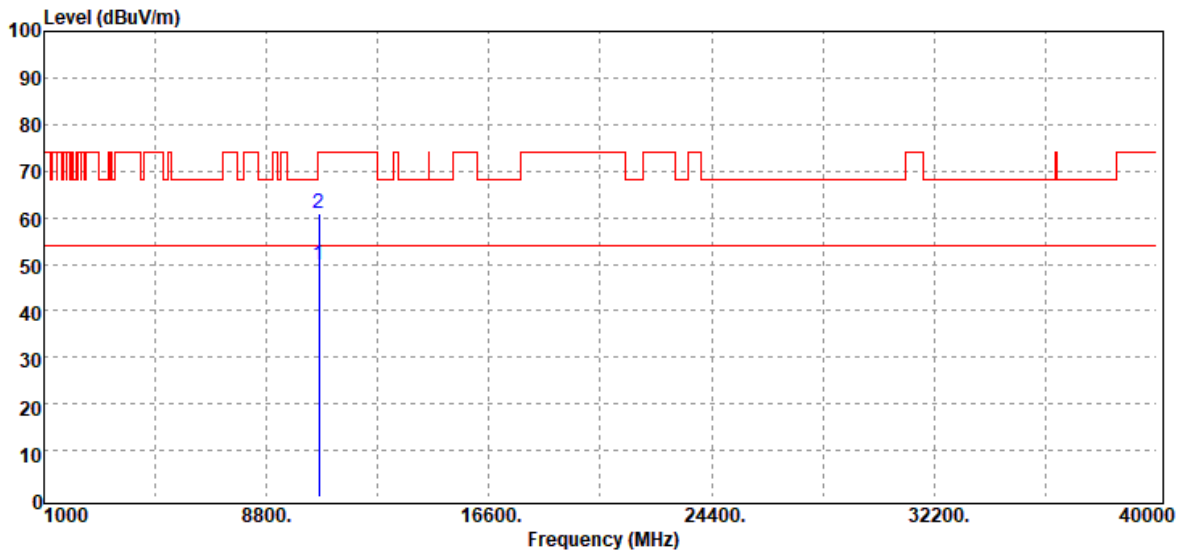

Frequency (MHz)	Reading (dBuV)	Correct Factor (dB/m)	Result (dBuV/m)	Limit (dBuV/m)	Margin (dB)	Remark
10640.00	34.73	15.05	49.78	54.00	-4.22	Average
10640.00	45.87	15.05	60.92	74.00	-13.08	Peak
N/A						

Remark:

1. Measuring frequencies from 1 GHz to the 10th harmonic of highest fundamental frequency.

Test Mode	IEEE 802.11n 40 MHz / 5270 MHz	Temp/Hum	28.2(°C)/ 50%RH
Test Item	Harmonic	Test Date	July 12, 2019
Polarize	Vertical	Test Engineer	Dally Hong
Detector	Peak		

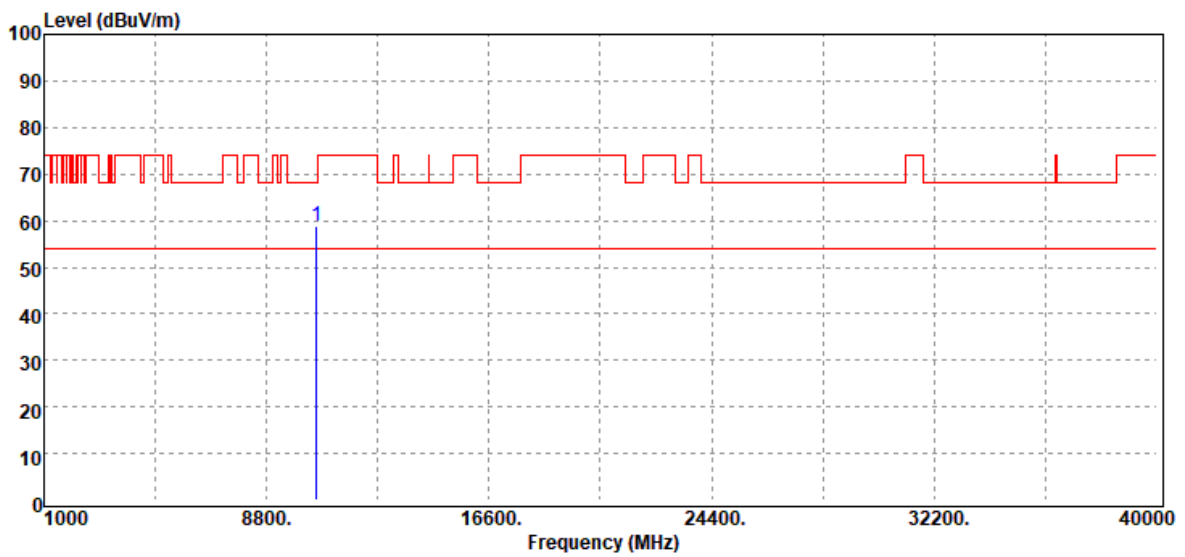

Frequency (MHz)	Reading (dBuV)	Correct Factor (dB/m)	Result (dBuV/m)	Limit (dBuV/m)	Margin (dB)	Remark
10540.00	43.78	14.95	58.73	68.20	-9.47	Peak
N/A						

Remark:

1. Measuring frequencies from 1 GHz to the 10th harmonic of highest fundamental frequency.
2. For above 1GHz, the EUT peak value was under average limit, therefore the Average value compliance with the average limit

Report No.: T190315W01-RP4

Test Mode	IEEE 802.11n 40 MHz / 5270 MHz	Temp/Hum	28.2(°C)/ 50%RH
Test Item	Harmonic	Test Date	July 12, 2019
Polarize	Horizontal	Test Engineer	Dally Hong
Detector	Peak		

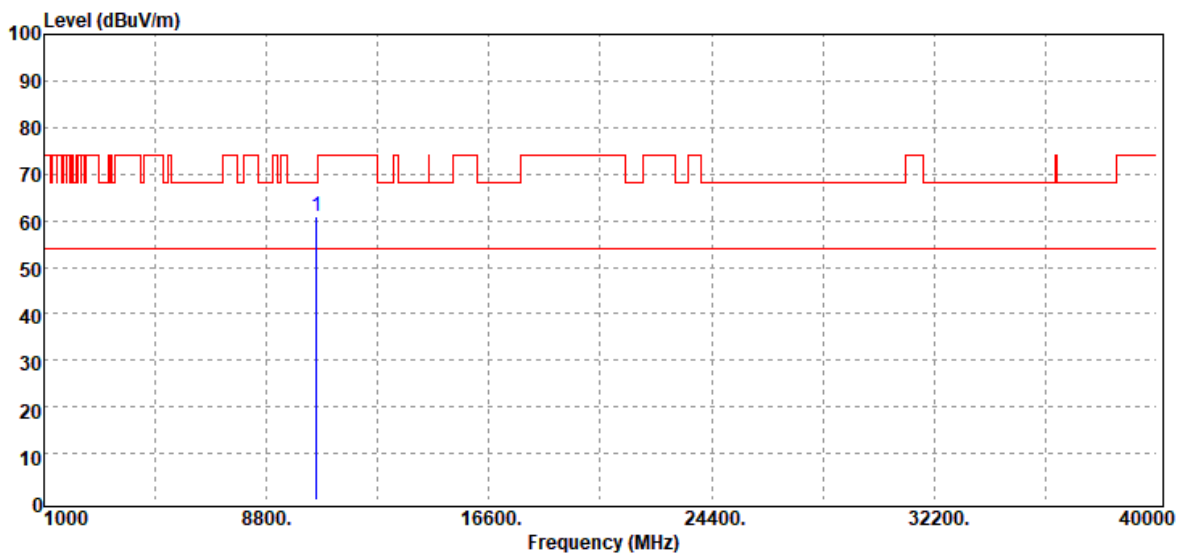

Frequency (MHz)	Reading (dBuV)	Correct Factor (dB/m)	Result (dBuV/m)	Limit (dBuV/m)	Margin (dB)	Remark
10540.00	45.99	14.95	60.94	68.20	-7.26	Peak
N/A						

Remark:

1. Measuring frequencies from 1 GHz to the 10th harmonic of highest fundamental frequency.
2. For above 1GHz, the EUT peak value was under average limit, therefore the Average value compliance with the average limit

Test Mode	IEEE 802.11n 40 MHz / 5310 MHz	Temp/Hum	28.2(°C)/ 50%RH
Test Item	Harmonic	Test Date	July 12, 2019
Polarize	Vertical	Test Engineer	Dally Hong
Detector	Peak and Average		

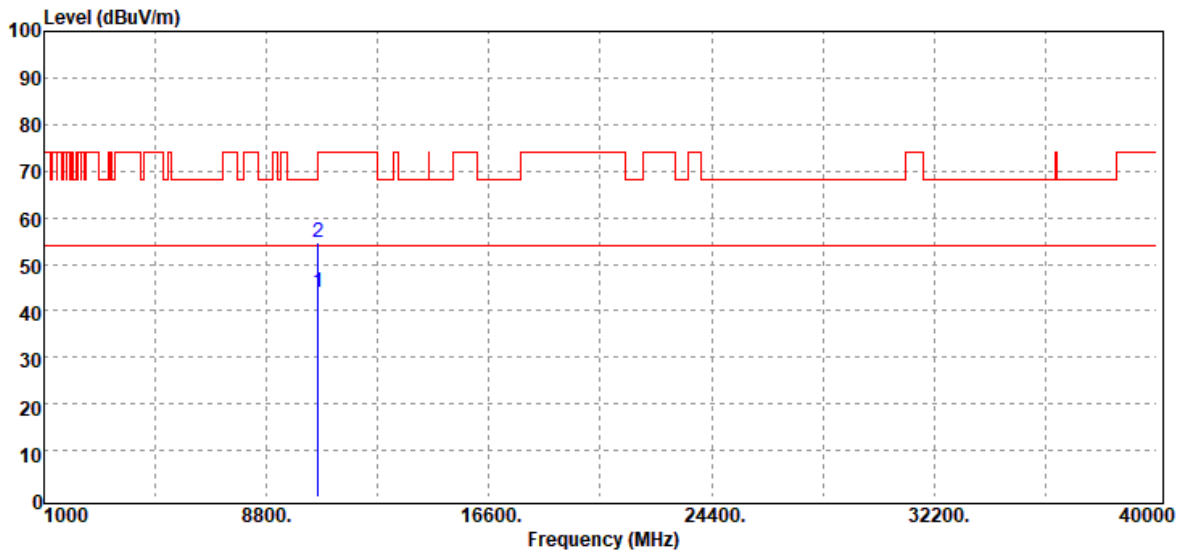

Frequency (MHz)	Reading (dBuV)	Correct Factor (dB/m)	Result (dBuV/m)	Limit (dBuV/m)	Margin (dB)	Remark
10620.00	29.31	14.81	44.12	54.00	-9.88	Average
10620.00	40.02	14.81	54.83	74.00	-19.17	Peak
N/A						

Remark:

- Measuring frequencies from 1 GHz to the 10th harmonic of highest fundamental frequency.

Test Mode	IEEE 802.11n 40 MHz / 5310 MHz	Temp/Hum	28.2(°C)/ 50%RH
Test Item	Harmonic	Test Date	July 12, 2019
Polarize	Horizontal	Test Engineer	Dally Hong
Detector	Peak and Average		

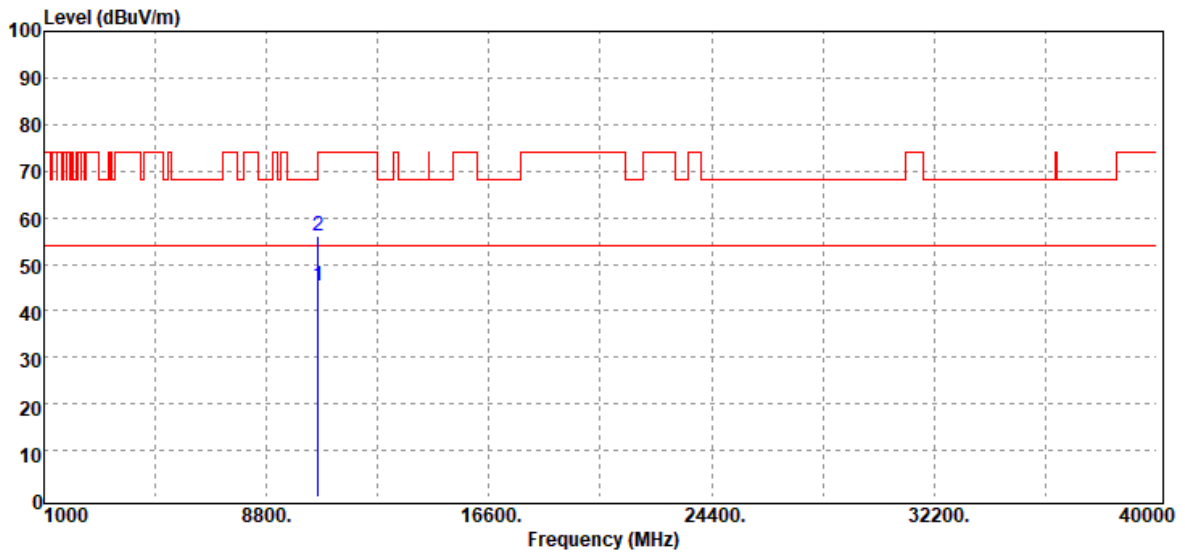

Frequency (MHz)	Reading (dBuV)	Correct Factor (dB/m)	Result (dBuV/m)	Limit (dBuV/m)	Margin (dB)	Remark
10620.00	30.65	14.81	45.46	54.00	-8.54	Average
10620.00	41.23	14.81	56.04	74.00	-17.96	Peak
N/A						

Remark:

1. Measuring frequencies from 1 GHz to the 10th harmonic of highest fundamental frequency.

Test Mode	IEEE 802.11ac VHT80 / 5290 MHz	Temp/Hum	28.2(°C)/ 50%RH
Test Item	Harmonic	Test Date	July 12, 2019
Polarize	Vertical	Test Engineer	Dally Hong
Detector	Peak		

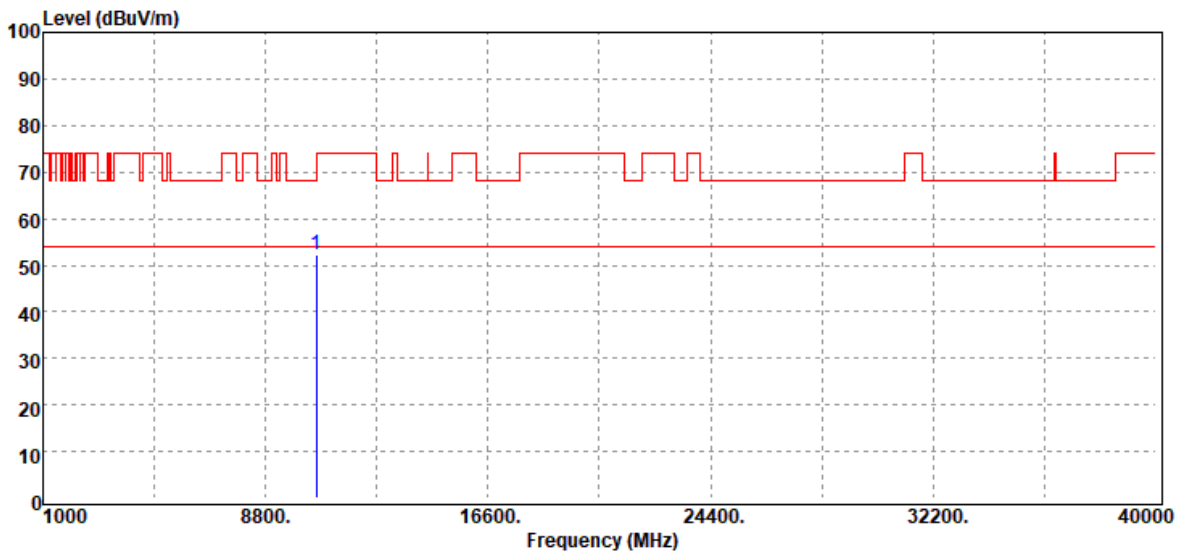

Frequency (MHz)	Reading (dBuV)	Correct Factor (dB/m)	Result (dBuV/m)	Limit (dBuV/m)	Margin (dB)	Remark
10580.00	37.64	14.56	52.20	68.20	-16.00	Peak
N/A						

Remark:

1. Measuring frequencies from 1 GHz to the 10th harmonic of highest fundamental frequency.
2. For above 1GHz, the EUT peak value was under average limit, therefore the Average value compliance with the average limit

Test Mode	IEEE 802.11ac VHT80 / 5290 MHz	Temp/Hum	28.2(°C)/ 50%RH
Test Item	Harmonic	Test Date	July 12, 2019
Polarize	Horizontal	Test Engineer	Dally Hong
Detector	Peak		

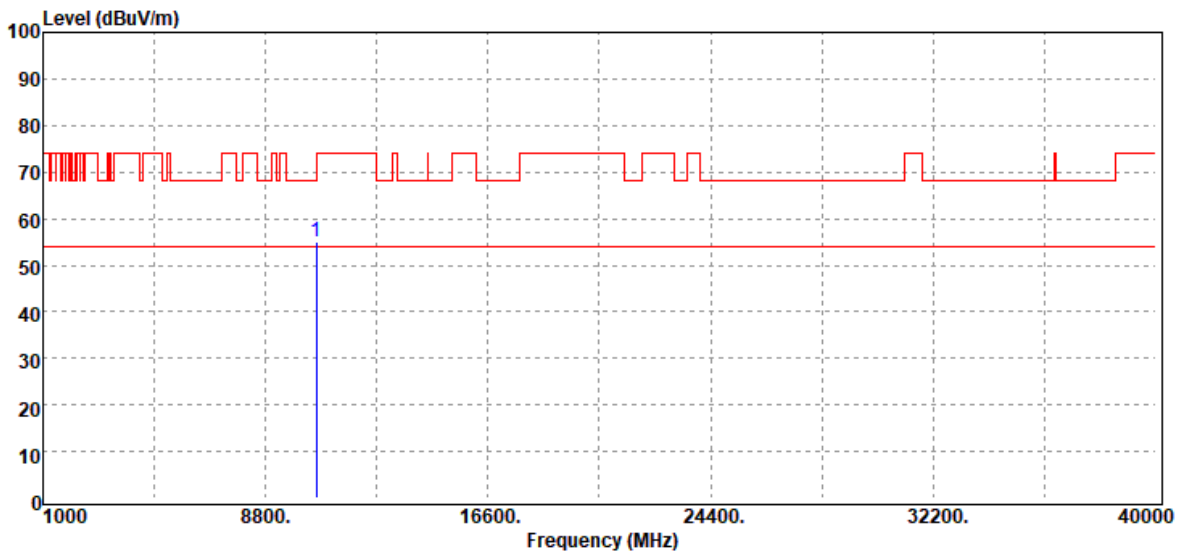

Frequency (MHz)	Reading (dBuV)	Correct Factor (dB/m)	Result (dBuV/m)	Limit (dBuV/m)	Margin (dB)	Remark
10580.00	40.59	14.56	55.15	68.20	-13.05	Peak
N/A						

Remark:

1. Measuring frequencies from 1 GHz to the 10th harmonic of highest fundamental frequency.
2. For above 1GHz, the EUT peak value was under average limit, therefore the Average value compliance with the average limit



Report No.: T190315W01-RP4

Above 1G Test Data for UNII-2c

Test Mode	IEEE 802.11a / 5500 MHz	Temp/Hum	28.2(°C)/ 50%RH
Test Item	Harmonic	Test Date	July 12, 2019
Polarize	Vertical	Test Engineer	Dally Hong
Detector	Peak and Average		

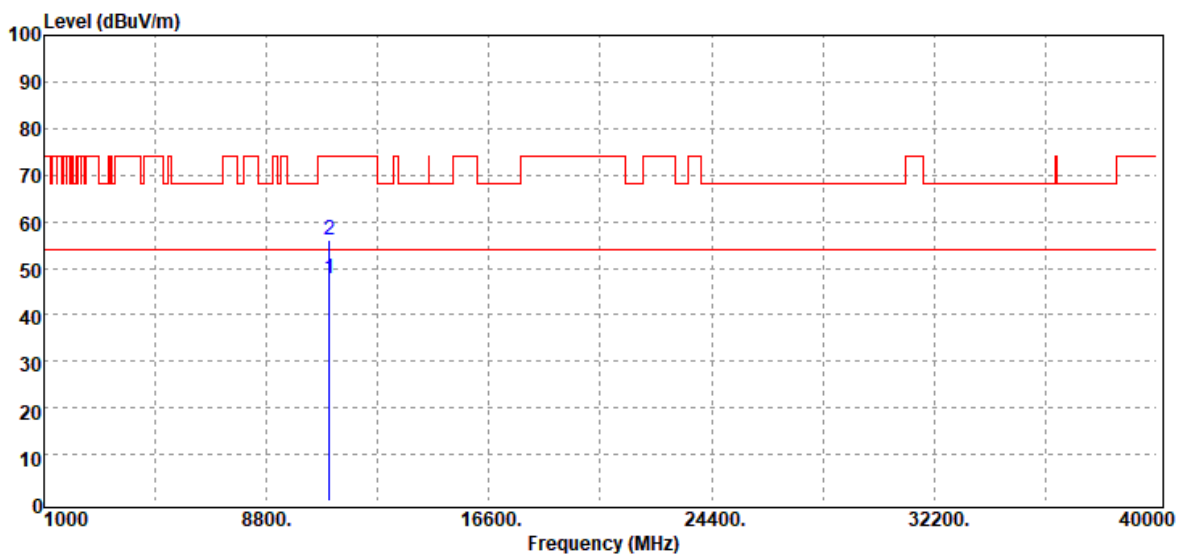

Frequency (MHz)	Reading (dBuV)	Correct Factor (dB/m)	Result (dBuV/m)	Limit (dBuV/m)	Margin (dB)	Remark
11000.00	32.11	15.80	47.91	54.00	-6.09	Average
11000.00	40.43	15.80	56.23	74.00	-17.77	Peak
N/A						

Remark:

1. Measuring frequencies from 1 GHz to the 10th harmonic of highest fundamental frequency.

Test Mode	IEEE 802.11a / 5500 MHz	Temp/Hum	28.2(°C)/ 50%RH
Test Item	Harmonic	Test Date	July 12, 2019
Polarize	Horizontal	Test Engineer	Dally Hong
Detector	Peak and Average		

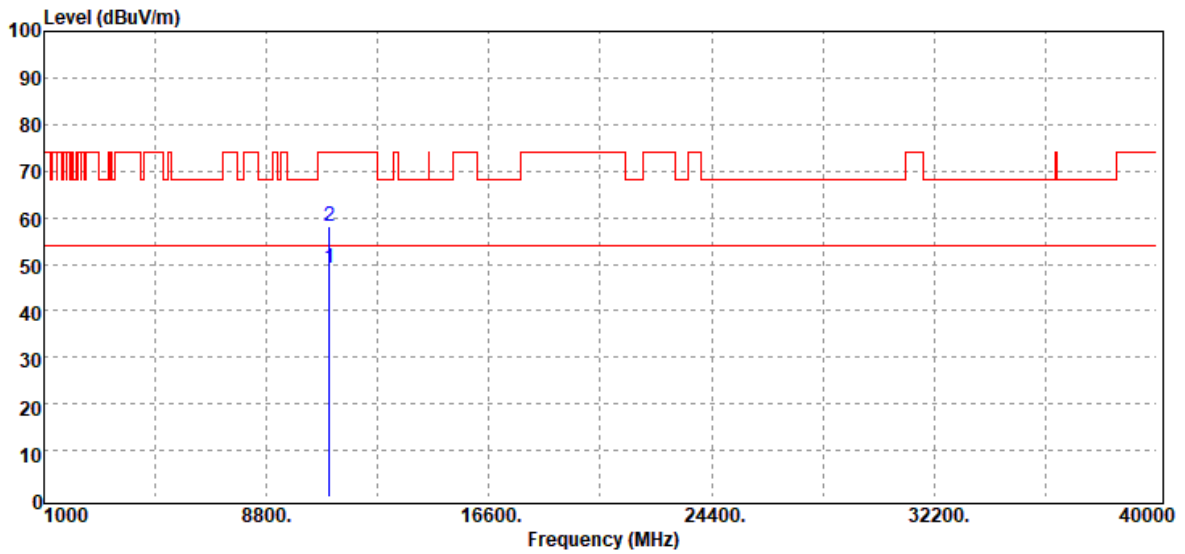

Frequency (MHz)	Reading (dBuV)	Correct Factor (dB/m)	Result (dBuV/m)	Limit (dBuV/m)	Margin (dB)	Remark
11000.00	33.37	15.80	49.17	54.00	-4.83	Average
11000.00	42.36	15.80	58.16	74.00	-15.84	Peak
N/A						

Remark:

1. Measuring frequencies from 1 GHz to the 10th harmonic of highest fundamental frequency.

Test Mode	IEEE 802.11a / 5580 MHz	Temp/Hum	28.2(°C)/ 50%RH
Test Item	Harmonic	Test Date	July 12, 2019
Polarize	Vertical	Test Engineer	Dally Hong
Detector	Peak and Average		

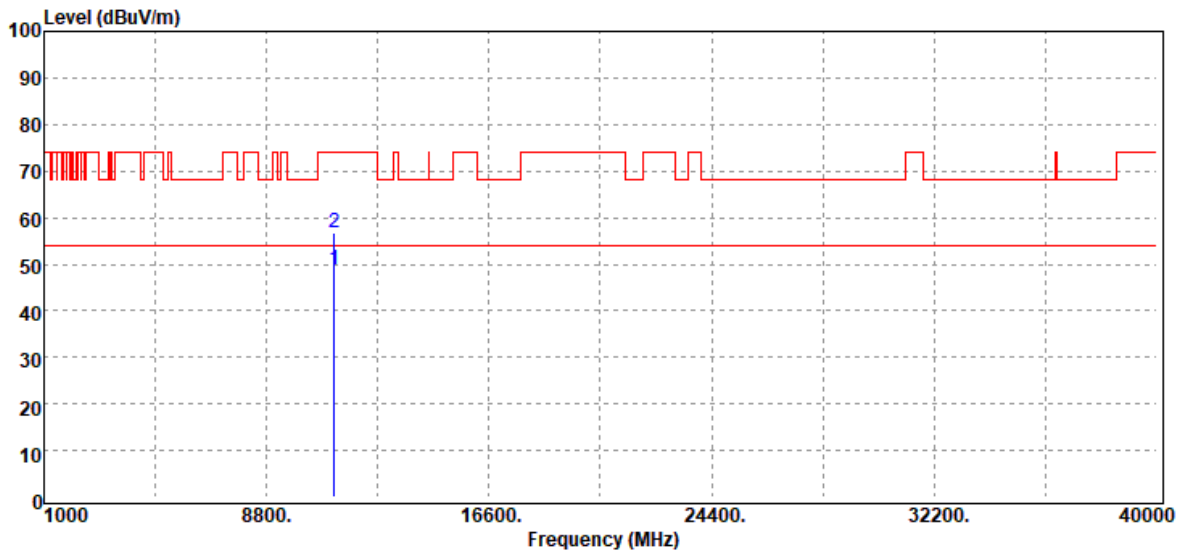

Frequency (MHz)	Reading (dBuV)	Correct Factor (dB/m)	Result (dBuV/m)	Limit (dBuV/m)	Margin (dB)	Remark
11160.00	32.51	16.17	48.68	54.00	-5.32	Average
11160.00	40.73	16.17	56.90	74.00	-17.10	Peak
N/A						

Remark:

- Measuring frequencies from 1 GHz to the 10th harmonic of highest fundamental frequency.



Report No.: T190315W01-RP4

Test Mode	IEEE 802.11a / 5580 MHz	Temp/Hum	28.2(°C)/ 50%RH
Test Item	Harmonic	Test Date	July 12, 2019
Polarize	Horizontal	Test Engineer	Dally Hong
Detector	Peak and Average		

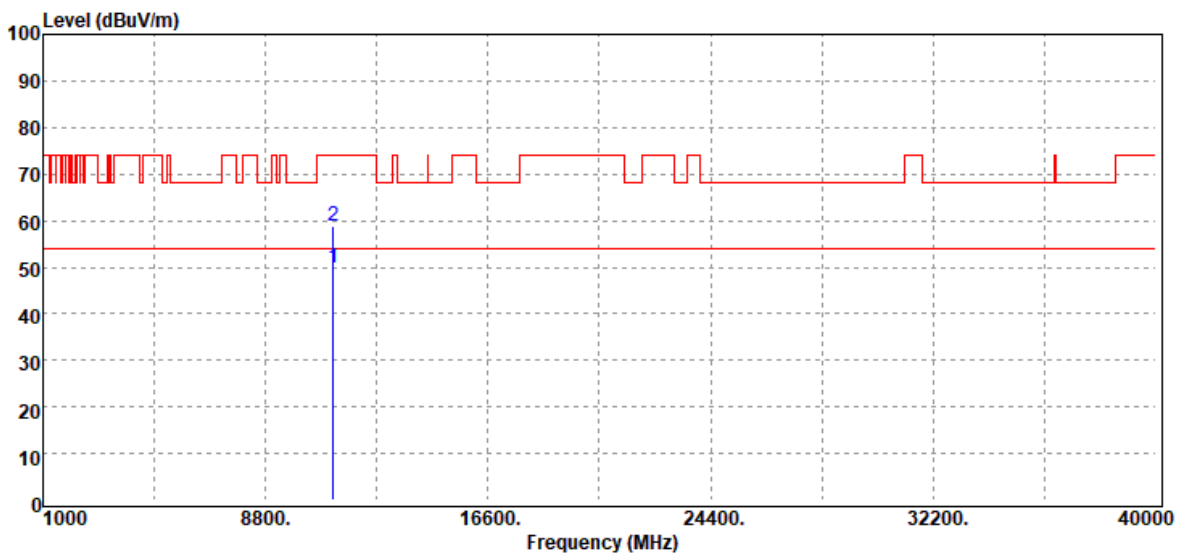

Frequency (MHz)	Reading (dBuV)	Correct Factor (dB/m)	Result (dBuV/m)	Limit (dBuV/m)	Margin (dB)	Remark
11160.00	33.52	16.17	49.69	54.00	-4.31	Average
11160.00	42.63	16.17	58.80	74.00	-15.20	Peak
N/A						

Remark:

1. Measuring frequencies from 1 GHz to the 10th harmonic of highest fundamental frequency.

Test Mode	IEEE 802.11a / 5700 MHz	Temp/Hum	28.2(°C)/ 50%RH
Test Item	Harmonic	Test Date	July 12, 2019
Polarize	Vertical	Test Engineer	Dally Hong
Detector	Peak and Average		

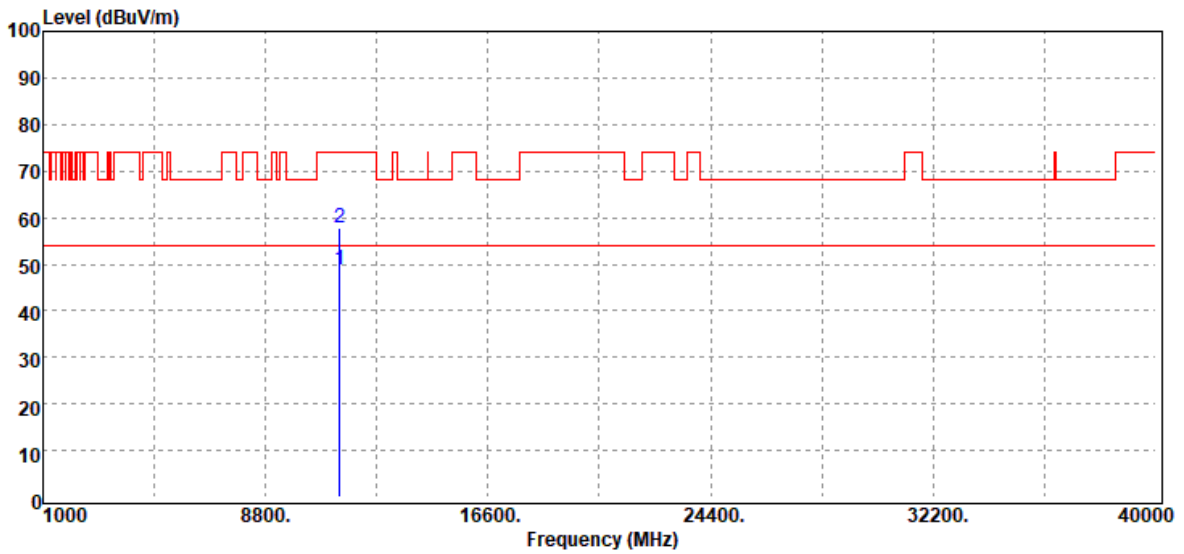

Frequency (MHz)	Reading (dBuV)	Correct Factor (dB/m)	Result (dBuV/m)	Limit (dBuV/m)	Margin (dB)	Remark
11400.00	32.76	15.94	48.70	54.00	-5.30	Average
11400.00	41.89	15.94	57.83	74.00	-16.17	Peak
N/A						

Remark:

1. Measuring frequencies from 1 GHz to the 10th harmonic of highest fundamental frequency.

Test Mode	IEEE 802.11a / 5700 MHz	Temp/Hum	28.2(°C)/ 50%RH
Test Item	Harmonic	Test Date	July 12, 2019
Polarize	Horizontal	Test Engineer	Dally Hong
Detector	Peak and Average		

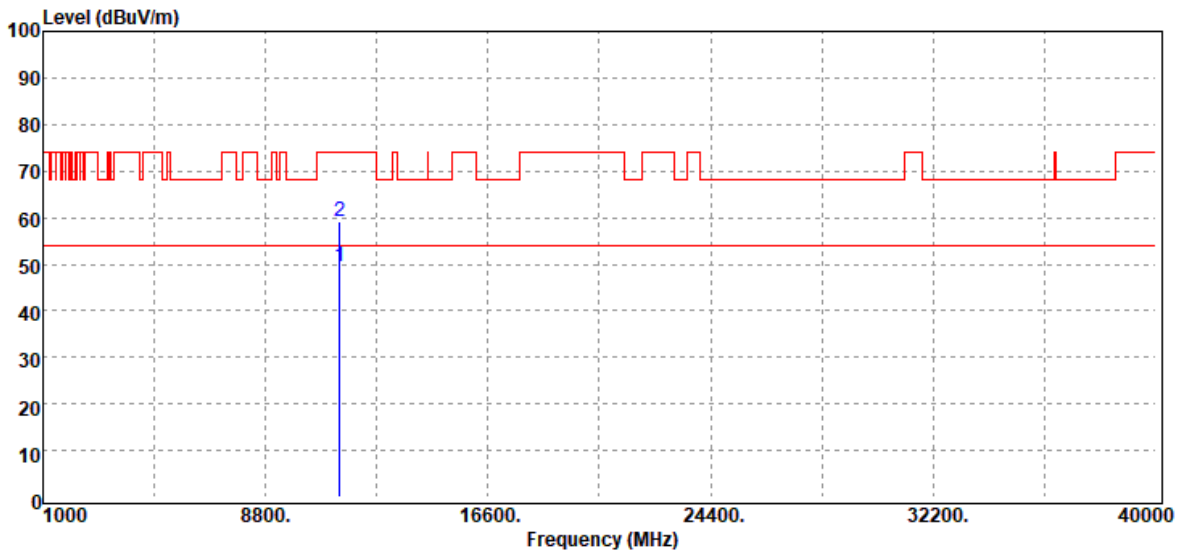

Frequency (MHz)	Reading (dBuV)	Correct Factor (dB/m)	Result (dBuV/m)	Limit (dBuV/m)	Margin (dB)	Remark
11400.00	33.67	15.94	49.61	54.00	-4.39	Average
11400.00	43.28	15.94	59.22	74.00	-14.78	Peak
N/A						

Remark:

1. Measuring frequencies from 1 GHz to the 10th harmonic of highest fundamental frequency.

Report No.: T190315W01-RP4

Test Mode	IEEE 802.11n 20 MHz / 5500 MHz	Temp/Hum	28.2(°C)/ 50%RH
Test Item	Harmonic	Test Date	July 12, 2019
Polarize	Vertical	Test Engineer	Dally Hong
Detector	Peak and Average		

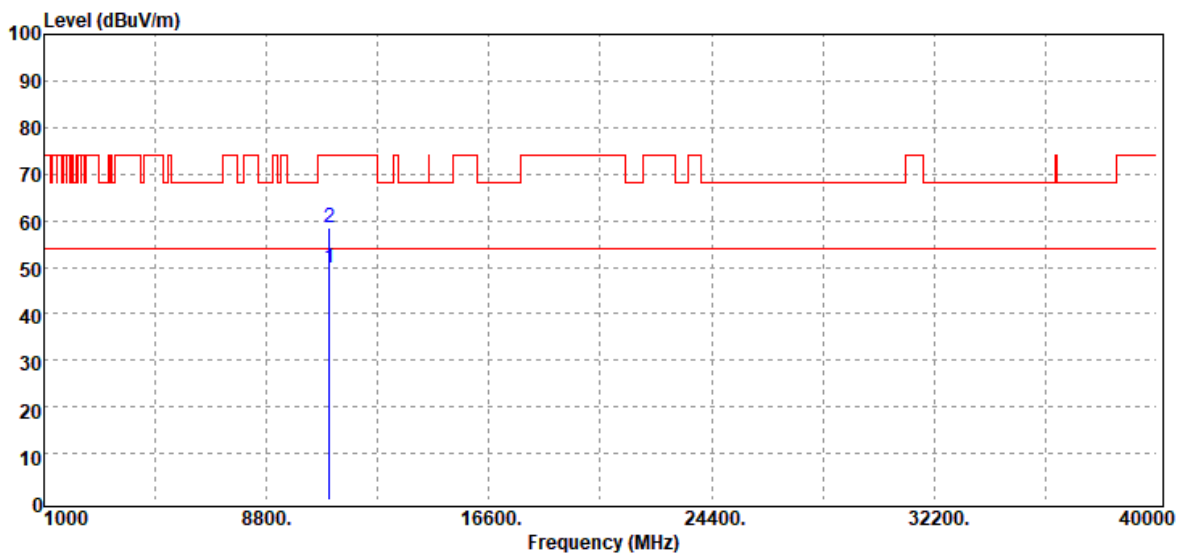

Frequency (MHz)	Reading (dBuV)	Correct Factor (dB/m)	Result (dBuV/m)	Limit (dBuV/m)	Margin (dB)	Remark
11000.00	33.88	15.80	49.68	54.00	-4.32	Average
11000.00	42.71	15.80	58.51	74.00	-15.49	Peak
N/A						

Remark:

1. Measuring frequencies from 1 GHz to the 10th harmonic of highest fundamental frequency.



Report No.: T190315W01-RP4

Test Mode	IEEE 802.11n 20 MHz / 5500 MHz	Temp/Hum	28.2(°C)/ 50%RH
Test Item	Harmonic	Test Date	July 12, 2019
Polarize	Horizontal	Test Engineer	Dally Hong
Detector	Peak and Average		

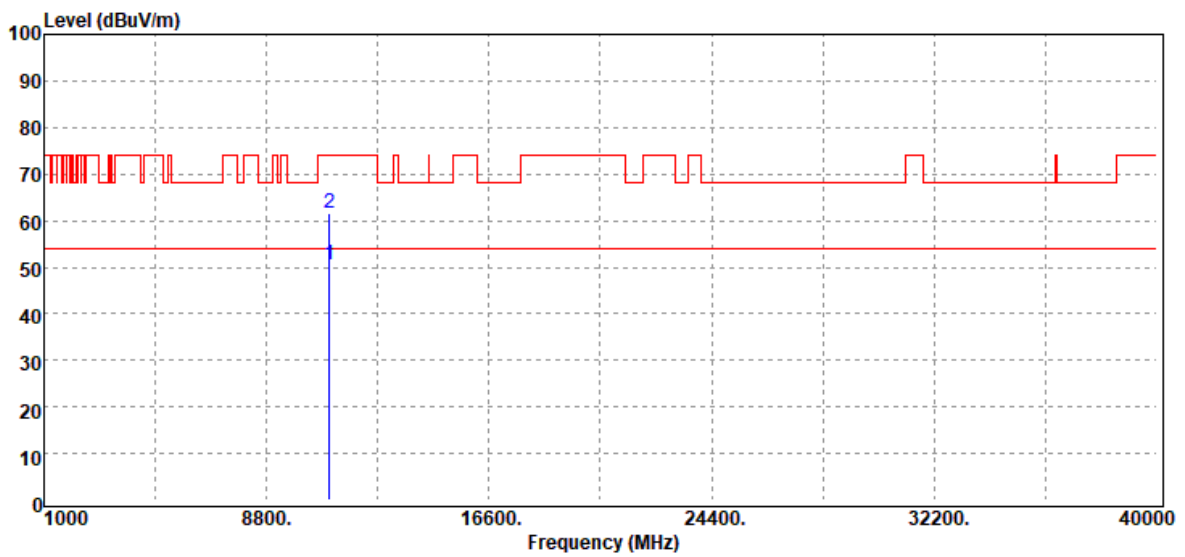

Frequency (MHz)	Reading (dBuV)	Correct Factor (dB/m)	Result (dBuV/m)	Limit (dBuV/m)	Margin (dB)	Remark
11000.00	34.59	15.80	50.39	54.00	-3.61	Average
11000.00	45.81	15.80	61.61	74.00	-12.39	Peak
N/A						

Remark:

- Measuring frequencies from 1 GHz to the 10th harmonic of highest fundamental frequency.

Test Mode	IEEE 802.11n 20 MHz / 5580 MHz	Temp/Hum	28.2(°C)/ 50%RH
Test Item	Harmonic	Test Date	July 12, 2019
Polarize	Vertical	Test Engineer	Dally Hong
Detector	Peak and Average		

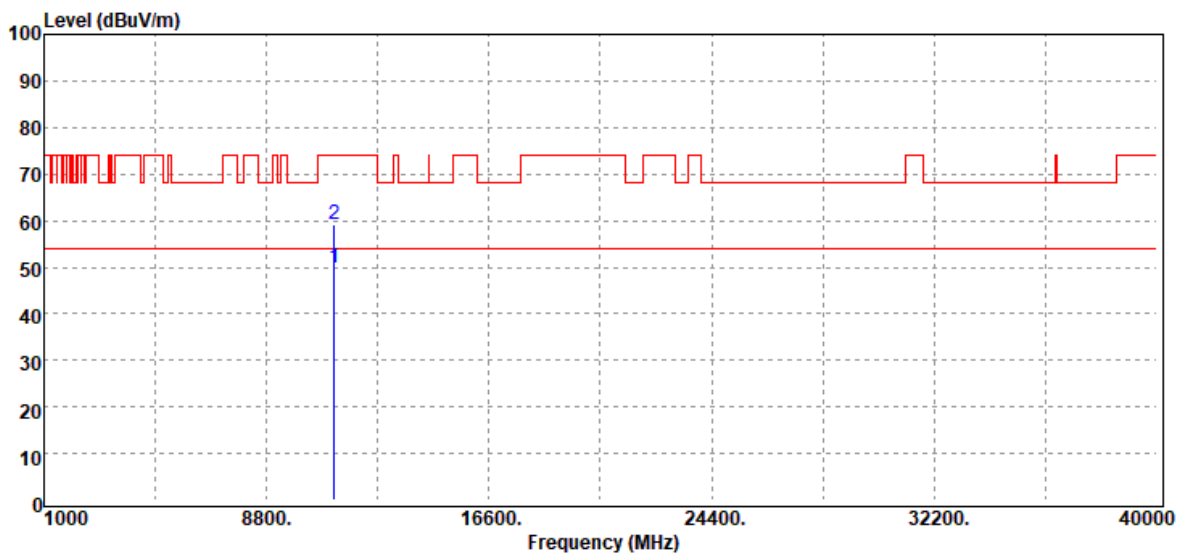

Frequency (MHz)	Reading (dBuV)	Correct Factor (dB/m)	Result (dBuV/m)	Limit (dBuV/m)	Margin (dB)	Remark
11160.00	33.76	16.17	49.93	54.00	-4.07	Average
11160.00	42.91	16.17	59.08	74.00	-14.92	Peak
N/A						

Remark:

1. Measuring frequencies from 1 GHz to the 10th harmonic of highest fundamental frequency.

Test Mode	IEEE 802.11n 20 MHz / 5580 MHz	Temp/Hum	28.2(°C)/ 50%RH
Test Item	Harmonic	Test Date	July 12, 2019
Polarize	Horizontal	Test Engineer	Dally Hong
Detector	Peak and Average		

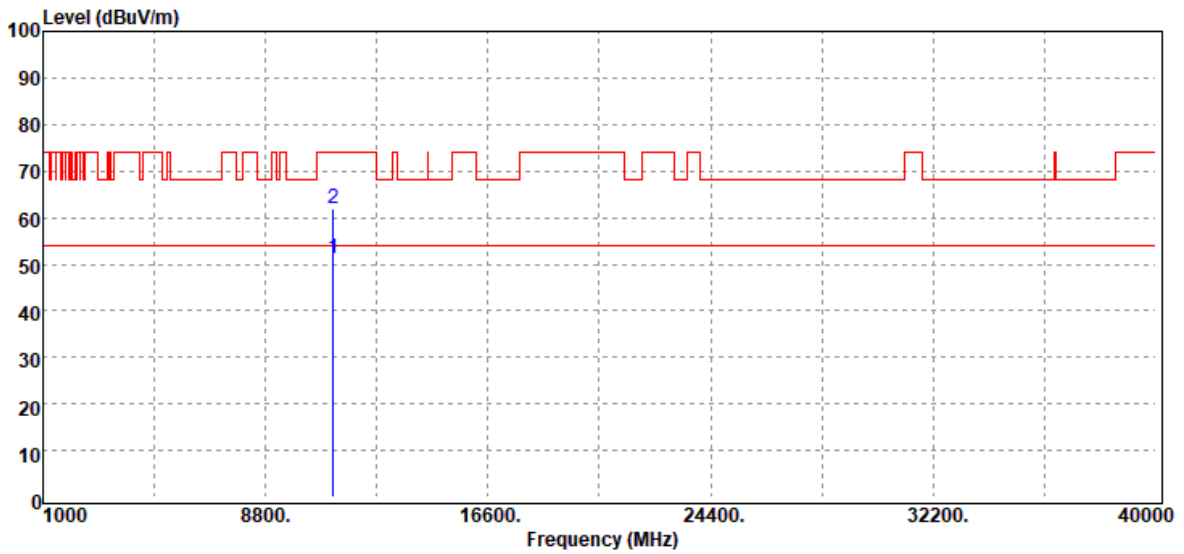

Frequency (MHz)	Reading (dBuV)	Correct Factor (dB/m)	Result (dBuV/m)	Limit (dBuV/m)	Margin (dB)	Remark
11160.00	34.91	16.17	51.08	54.00	-2.92	Average
11160.00	45.83	16.17	62.00	74.00	-12.00	Peak
N/A						

Remark:

- Measuring frequencies from 1 GHz to the 10th harmonic of highest fundamental frequency.

Test Mode	IEEE 802.11n 20 MHz / 5700 MHz	Temp/Hum	28.2(°C)/ 50%RH
Test Item	Harmonic	Test Date	July 12, 2019
Polarize	Vertical	Test Engineer	Dally Hong
Detector	Peak and Average		

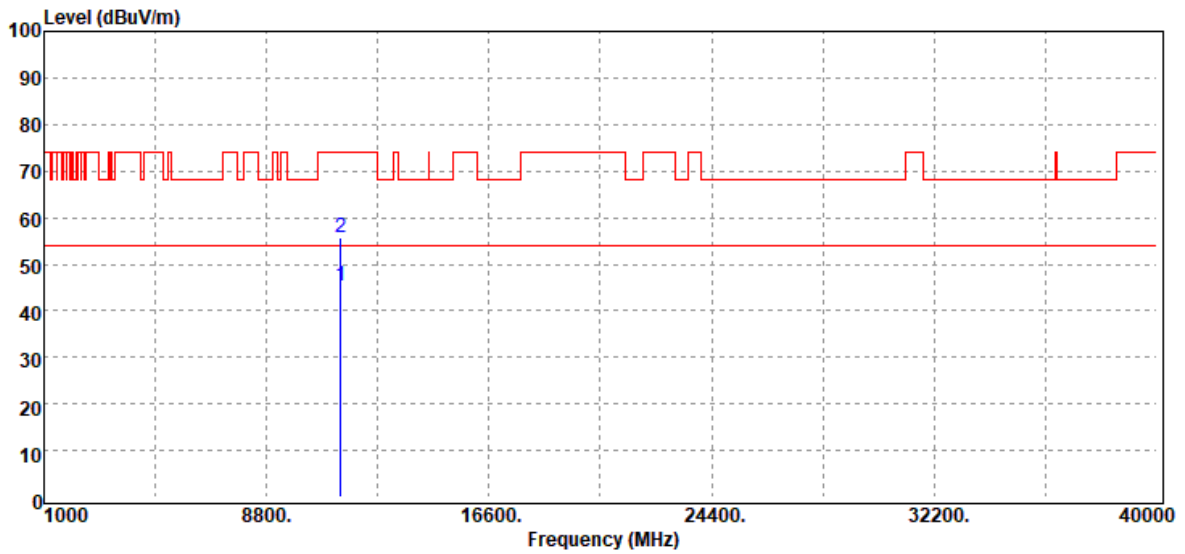

Frequency (MHz)	Reading (dBuV)	Correct Factor (dB/m)	Result (dBuV/m)	Limit (dBuV/m)	Margin (dB)	Remark
11400.00	29.52	15.94	45.46	54.00	-8.54	Average
11400.00	39.82	15.94	55.76	74.00	-18.24	Peak
N/A						

Remark:

1. Measuring frequencies from 1 GHz to the 10th harmonic of highest fundamental frequency.

Test Mode	IEEE 802.11n 20 MHz / 5700 MHz	Temp/Hum	28.2(°C)/ 50%RH
Test Item	Harmonic	Test Date	July 12, 2019
Polarize	Horizontal	Test Engineer	Dally Hong
Detector	Peak and Average		

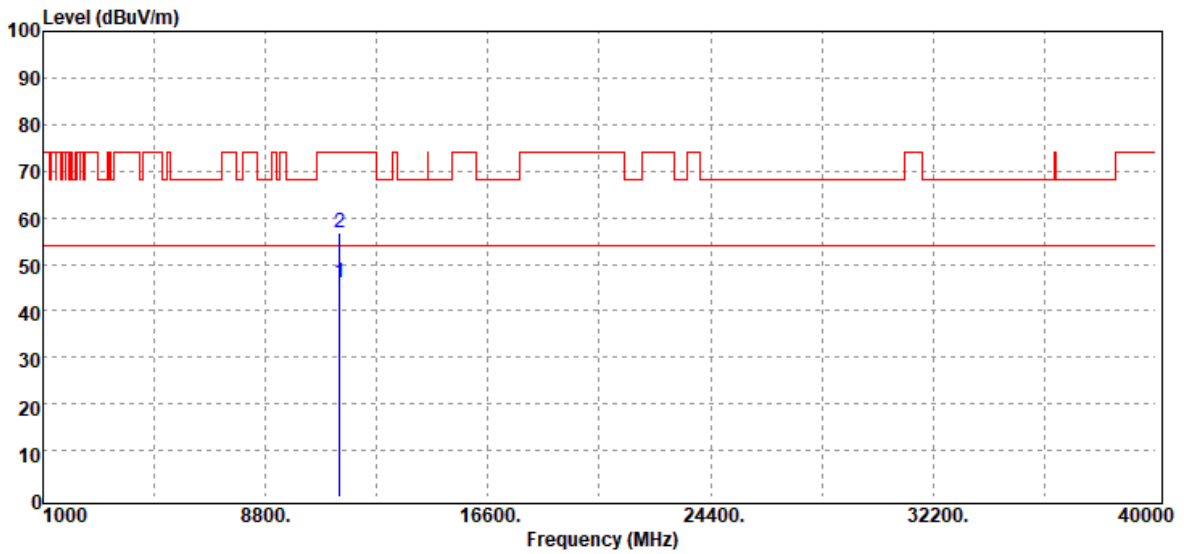

Frequency (MHz)	Reading (dBuV)	Correct Factor (dB/m)	Result (dBuV/m)	Limit (dBuV/m)	Margin (dB)	Remark
11400.00	30.25	15.94	46.19	54.00	-7.81	Average
11400.00	40.66	15.94	56.60	74.00	-17.40	Peak
N/A						

Remark:

1. Measuring frequencies from 1 GHz to the 10th harmonic of highest fundamental frequency.

Test Mode	IEEE 802.11n 40 MHz / 5510 MHz	Temp/Hum	28.2(°C)/ 50%RH
Test Item	Harmonic	Test Date	July 12, 2019
Polarize	Vertical	Test Engineer	Dally Hong
Detector	Peak and Average		

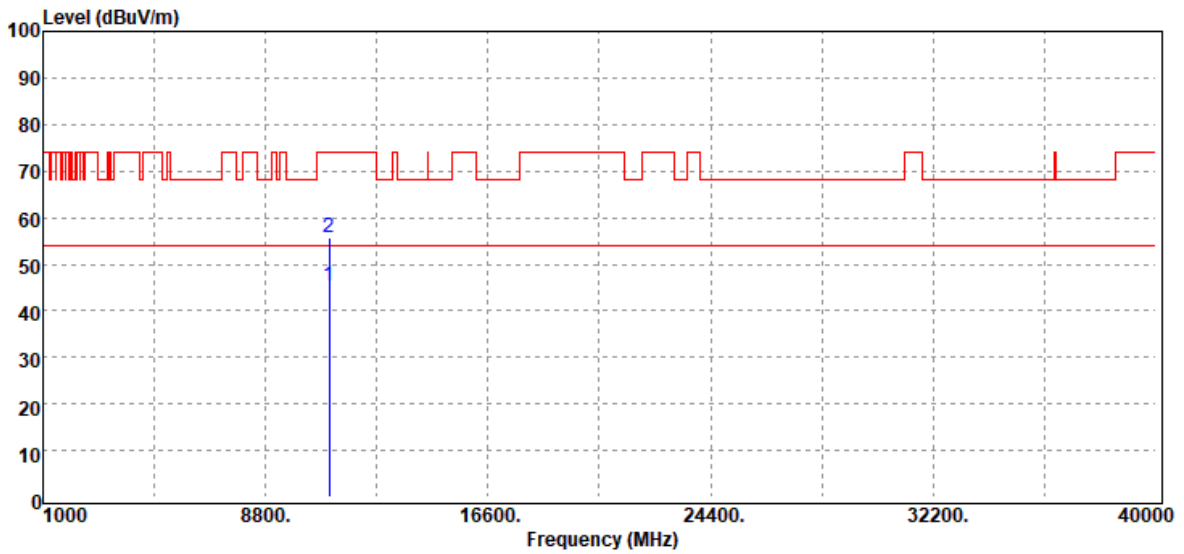

Frequency (MHz)	Reading (dBuV)	Correct Factor (dB/m)	Result (dBuV/m)	Limit (dBuV/m)	Margin (dB)	Remark
11020.00	29.56	15.84	45.40	54.00	-8.60	Average
11020.00	39.71	15.84	55.55	74.00	-18.45	Peak
N/A						

Remark:

1. Measuring frequencies from 1 GHz to the 10th harmonic of highest fundamental frequency.

Test Mode	IEEE 802.11n 40 MHz / 5510 MHz	Temp/Hum	28.2(°C)/ 50%RH
Test Item	Harmonic	Test Date	July 12, 2019
Polarize	Horizontal	Test Engineer	Dally Hong
Detector	Peak and Average		

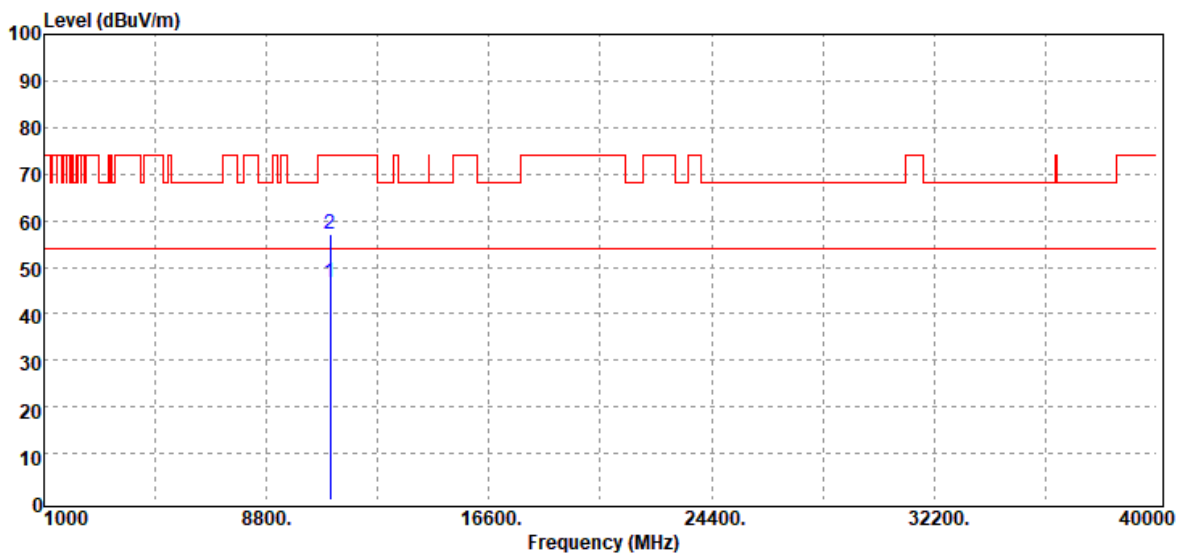

Frequency (MHz)	Reading (dBuV)	Correct Factor (dB/m)	Result (dBuV/m)	Limit (dBuV/m)	Margin (dB)	Remark
11020.00	30.85	15.84	46.69	54.00	-7.31	Average
11020.00	41.17	15.84	57.01	74.00	-16.99	Peak
N/A						

Remark:

1. Measuring frequencies from 1 GHz to the 10th harmonic of highest fundamental frequency.

Test Mode	IEEE 802.11n 40 MHz / 5550 MHz	Temp/Hum	28.2(°C)/ 50%RH
Test Item	Harmonic	Test Date	July 12, 2019
Polarize	Vertical	Test Engineer	Dally Hong
Detector	Peak and Average		

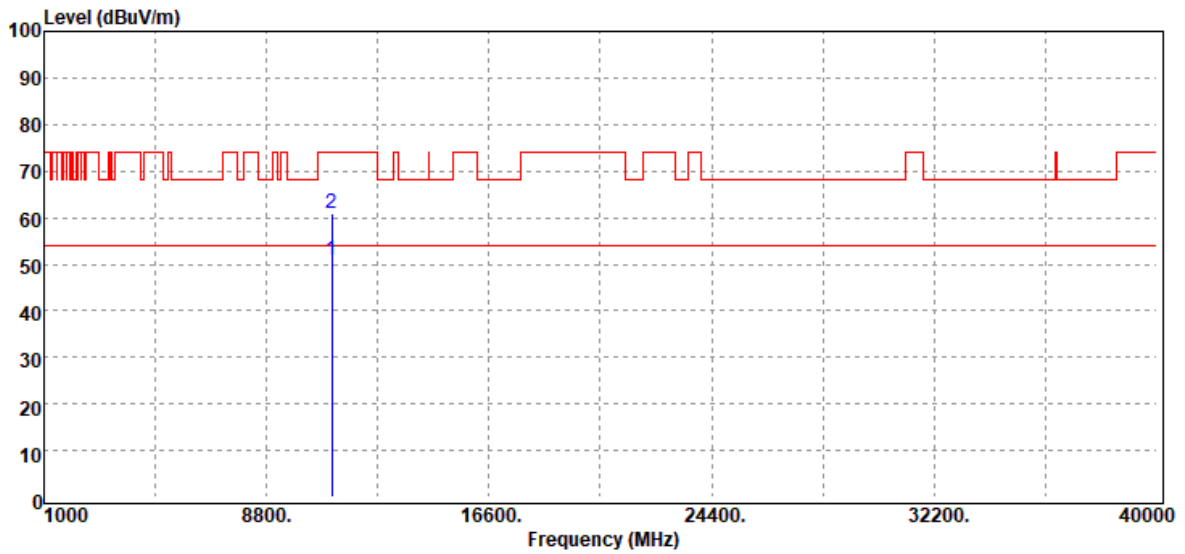

Frequency (MHz)	Reading (dBuV)	Correct Factor (dB/m)	Result (dBuV/m)	Limit (dBuV/m)	Margin (dB)	Remark
11100.00	34.63	16.39	51.02	54.00	-2.98	Average
11100.00	44.39	16.39	60.78	74.00	-13.22	Peak
N/A						

Remark:

1. Measuring frequencies from 1 GHz to the 10th harmonic of highest fundamental frequency.

Test Mode	IEEE 802.11n 40 MHz / 5550 MHz	Temp/Hum	28.2(°C)/ 50%RH
Test Item	Harmonic	Test Date	July 12, 2019
Polarize	Horizontal	Test Engineer	Dally Hong
Detector	Peak and Average		

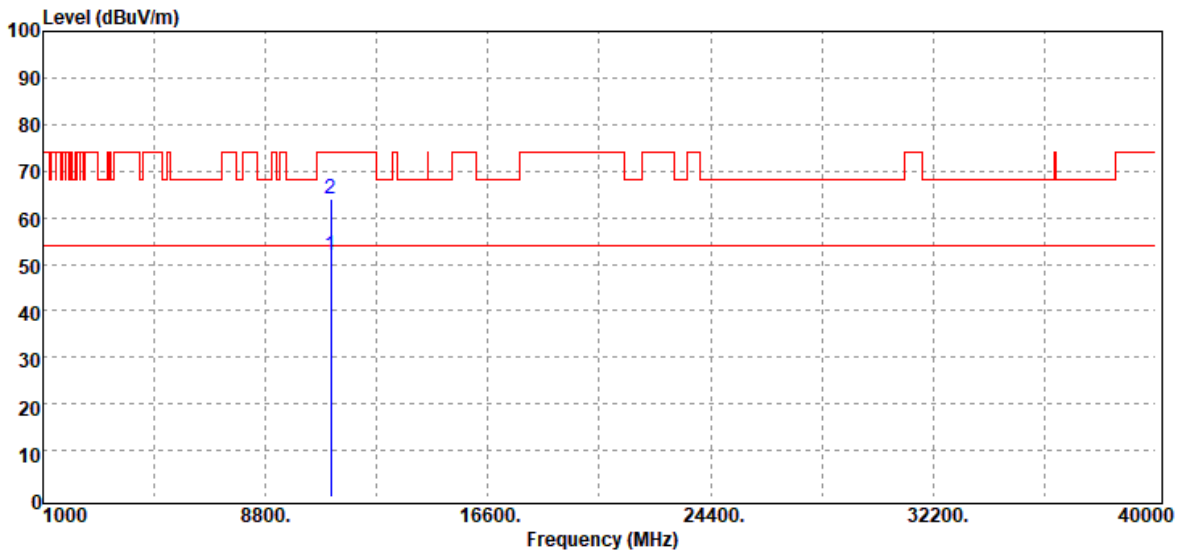

Frequency (MHz)	Reading (dBuV)	Correct Factor (dB/m)	Result (dBuV/m)	Limit (dBuV/m)	Margin (dB)	Remark
11100.00	35.39	16.39	51.78	54.00	-2.22	Average
11100.00	47.71	16.39	64.10	74.00	-9.90	Peak
N/A						

Remark:

1. Measuring frequencies from 1 GHz to the 10th harmonic of highest fundamental frequency.



Report No.: T190315W01-RP4

Page: 155 / 192
Rev.: 01

Test Mode	IEEE 802.11n 40 MHz / 5670 MHz	Temp/Hum	28.2(°C)/ 50%RH
Test Item	Harmonic	Test Date	July 12, 2019
Polarize	Vertical	Test Engineer	Dally Hong
Detector	Peak and Average		

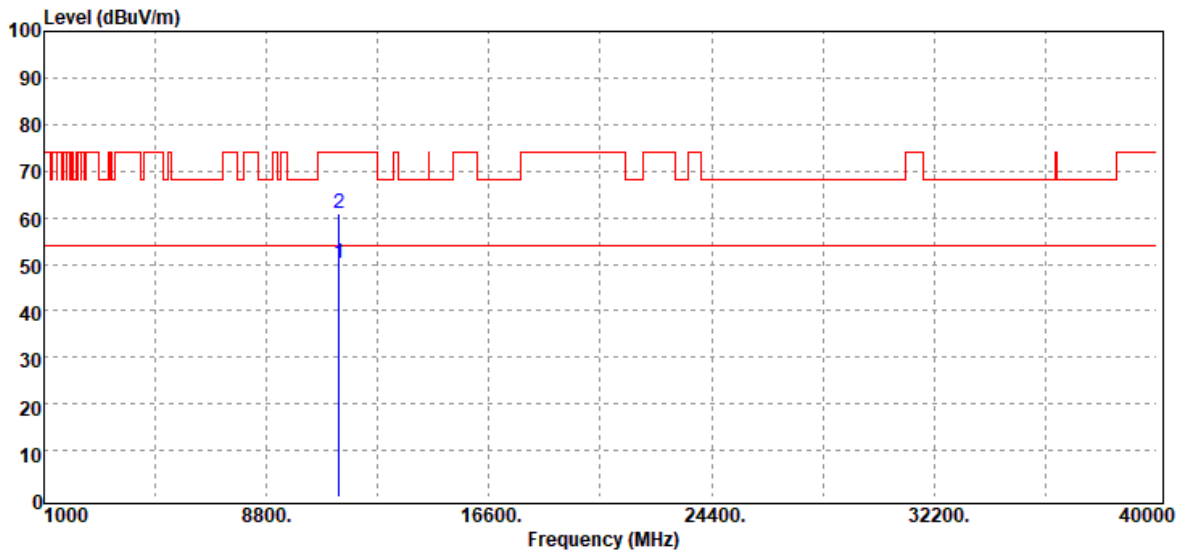

Frequency (MHz)	Reading (dBuV)	Correct Factor (dB/m)	Result (dBuV/m)	Limit (dBuV/m)	Margin (dB)	Remark
11340.00	34.26	15.99	50.25	54.00	-3.75	Average
11340.00	44.98	15.99	60.97	74.00	-13.03	Peak
N/A						

Remark:

1. Measuring frequencies from 1 GHz to the 10th harmonic of highest fundamental frequency.

Test Mode	IEEE 802.11n 40 MHz / 5670 MHz	Temp/Hum	28.2(°C)/ 50%RH
Test Item	Harmonic	Test Date	July 12, 2019
Polarize	Horizontal	Test Engineer	Dally Hong
Detector	Peak and Average		

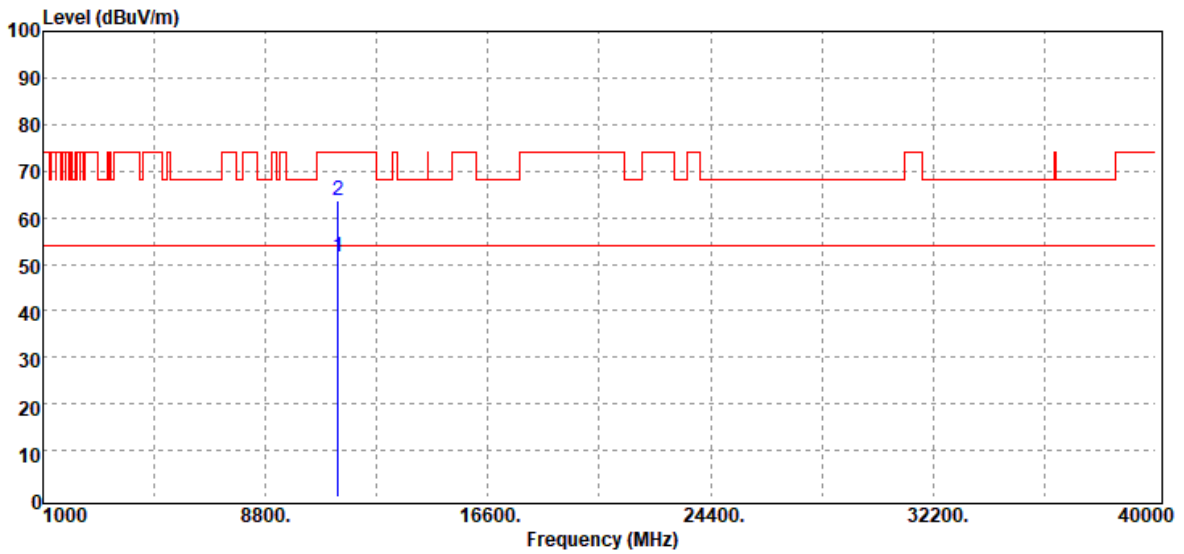

Frequency (MHz)	Reading (dBuV)	Correct Factor (dB/m)	Result (dBuV/m)	Limit (dBuV/m)	Margin (dB)	Remark
11340.00	35.71	15.99	51.70	54.00	-2.30	Average
11340.00	47.81	15.99	63.80	74.00	-10.20	Peak
N/A						

Remark:

- Measuring frequencies from 1 GHz to the 10th harmonic of highest fundamental frequency.

Test Mode	IEEE 802.11ac VHT80 / 5530 MHz	Temp/Hum	28.2(°C)/ 50%RH
Test Item	Harmonic	Test Date	July 12, 2019
Polarize	Vertical	Test Engineer	Dally Hong
Detector	Peak and Average		

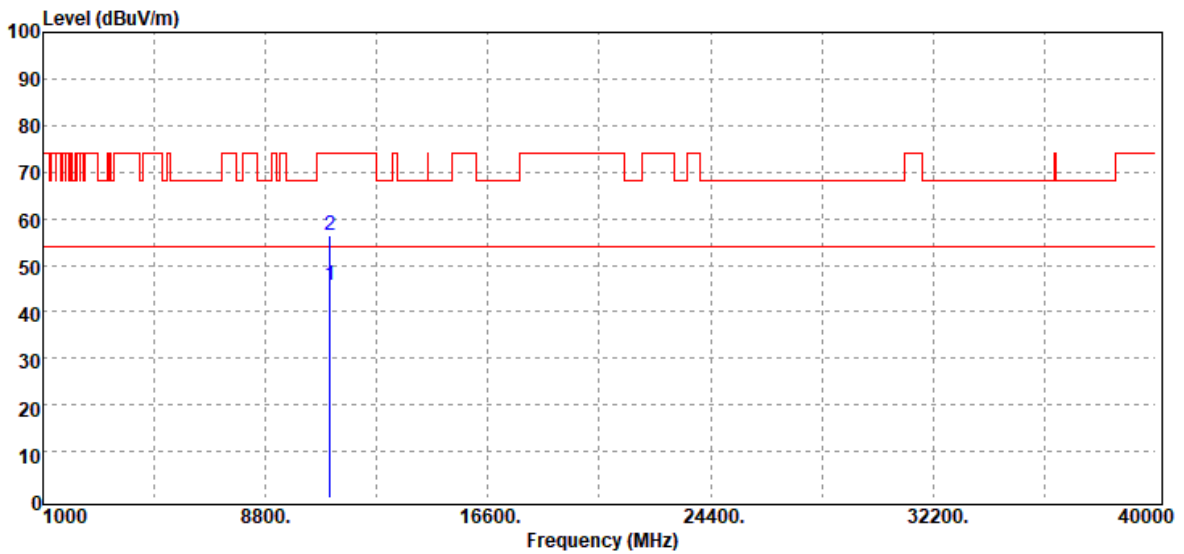

Frequency (MHz)	Reading (dBUV)	Correct Factor (dB/m)	Result (dBUV/m)	Limit (dBUV/m)	Margin (dB)	Remark
11060.00	29.73	16.08	45.81	54.00	-8.19	Average
11060.00	40.35	16.08	56.43	74.00	-17.57	Peak
N/A						

Remark:

- Measuring frequencies from 1 GHz to the 10th harmonic of highest fundamental frequency.

Test Mode	IEEE 802.11ac VHT80 / 5530 MHz	Temp/Hum	28.2(°C)/ 50%RH
Test Item	Harmonic	Test Date	July 12, 2019
Polarize	Horizontal	Test Engineer	Dally Hong
Detector	Peak and Average		

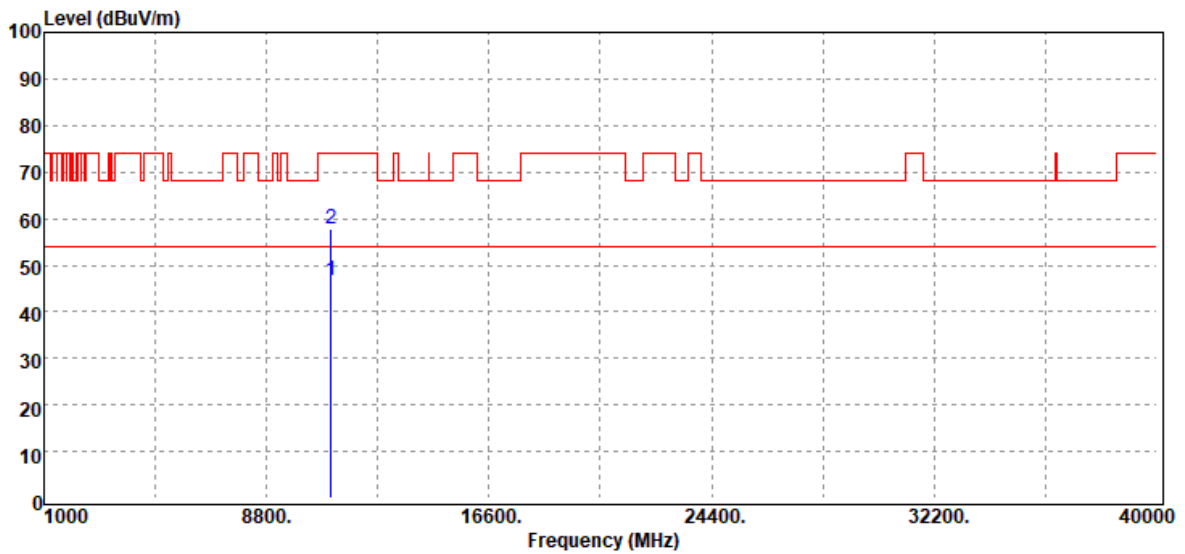

Frequency (MHz)	Reading (dBuV)	Correct Factor (dB/m)	Result (dBuV/m)	Limit (dBuV/m)	Margin (dB)	Remark
11060.00	30.58	16.08	46.66	54.00	-7.34	Average
11060.00	41.72	16.08	57.80	74.00	-16.20	Peak
N/A						

Remark:

- Measuring frequencies from 1 GHz to the 10th harmonic of highest fundamental frequency.



Report No.: T190315W01-RP4

Page: 159 / 192
Rev.: 01

Above 1G Test Data for UNII-3

Test Mode	IEEE 802.11a / 5745 MHz	Temp/Hum	28.2(°C)/ 50%RH
Test Item	Harmonic	Test Date	July 12, 2019
Polarize	Vertical	Test Engineer	Dally Hong
Detector	Peak and Average		

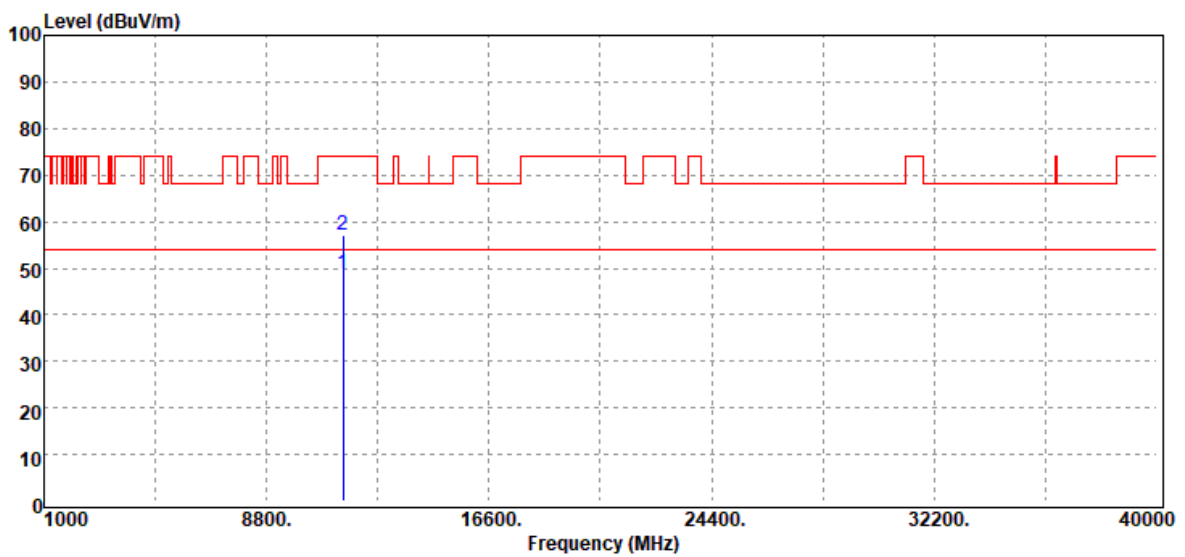

Frequency (MHz)	Reading (dBuV)	Correct Factor (dB/m)	Result (dBuV/m)	Limit (dBuV/m)	Margin (dB)	Remark
11490.00	33.11	15.57	48.68	54.00	-5.32	Average
11490.00	41.67	15.57	57.24	74.00	-16.76	Peak
N/A						

Remark:

1. Measuring frequencies from 1 GHz to the 10th harmonic of highest fundamental frequency.

Test Mode	IEEE 802.11a / 5745 MHz	Temp/Hum	28.2(°C)/ 50%RH
Test Item	Harmonic	Test Date	July 12, 2019
Polarize	Horizontal	Test Engineer	Dally Hong
Detector	Peak and Average		

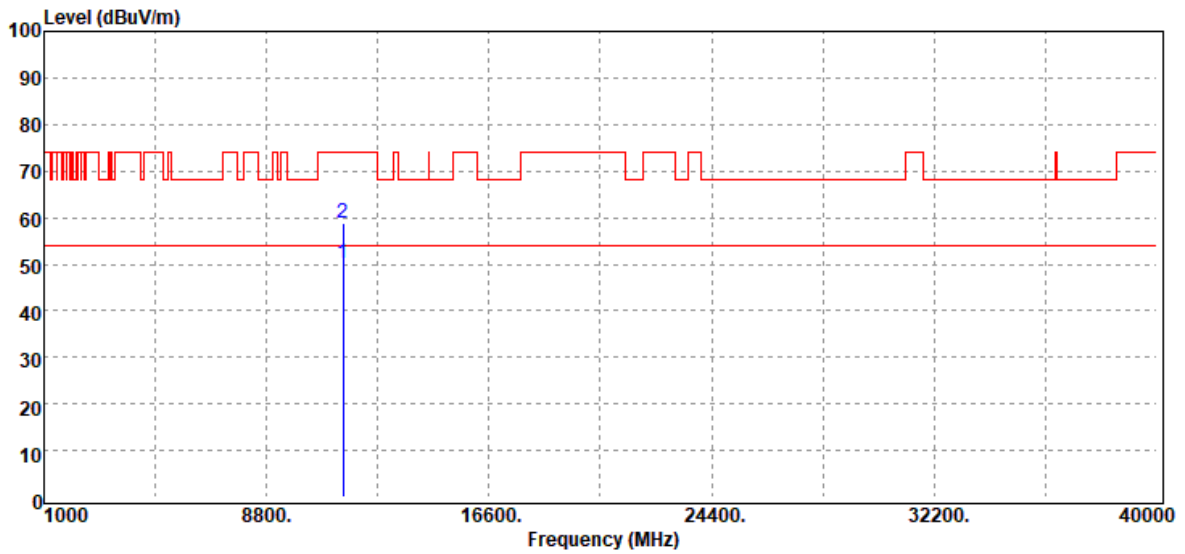

Frequency (MHz)	Reading (dBuV)	Correct Factor (dB/m)	Result (dBuV/m)	Limit (dBuV/m)	Margin (dB)	Remark
11490.00	34.54	15.57	50.11	54.00	-3.89	Average
11490.00	43.29	15.57	58.86	74.00	-15.14	Peak
N/A						

Remark:

1. Measuring frequencies from 1 GHz to the 10th harmonic of highest fundamental frequency.

Test Mode	IEEE 802.11a / 5785 MHz	Temp/Hum	28.2(°C)/ 50%RH
Test Item	Harmonic	Test Date	July 12, 2019
Polarize	Vertical	Test Engineer	Dally Hong
Detector	Peak and Average		

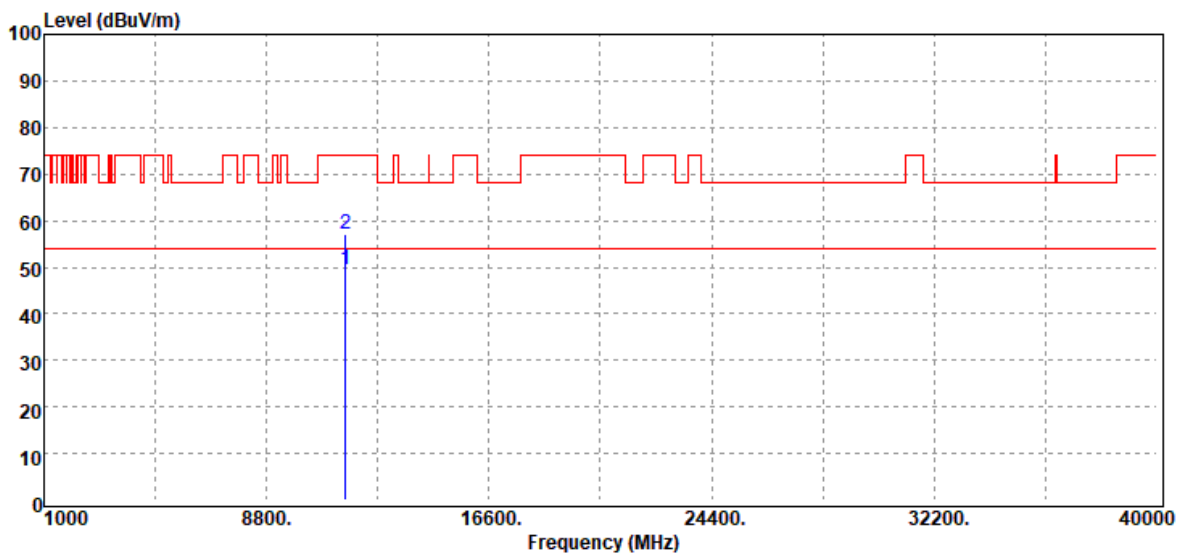

Frequency (MHz)	Reading (dBuV)	Correct Factor (dB/m)	Result (dBuV/m)	Limit (dBuV/m)	Margin (dB)	Remark
11570.00	33.88	15.50	49.38	54.00	-4.62	Average
11570.00	41.62	15.50	57.12	74.00	-16.88	Peak
N/A						

Remark:

1. Measuring frequencies from 1 GHz to the 10th harmonic of highest fundamental frequency.



Report No.: T190315W01-RP4

Test Mode	IEEE 802.11a / 5785 MHz	Temp/Hum	28.2(°C)/ 50%RH
Test Item	Harmonic	Test Date	July 12, 2019
Polarize	Horizontal	Test Engineer	Dally Hong
Detector	Peak and Average		

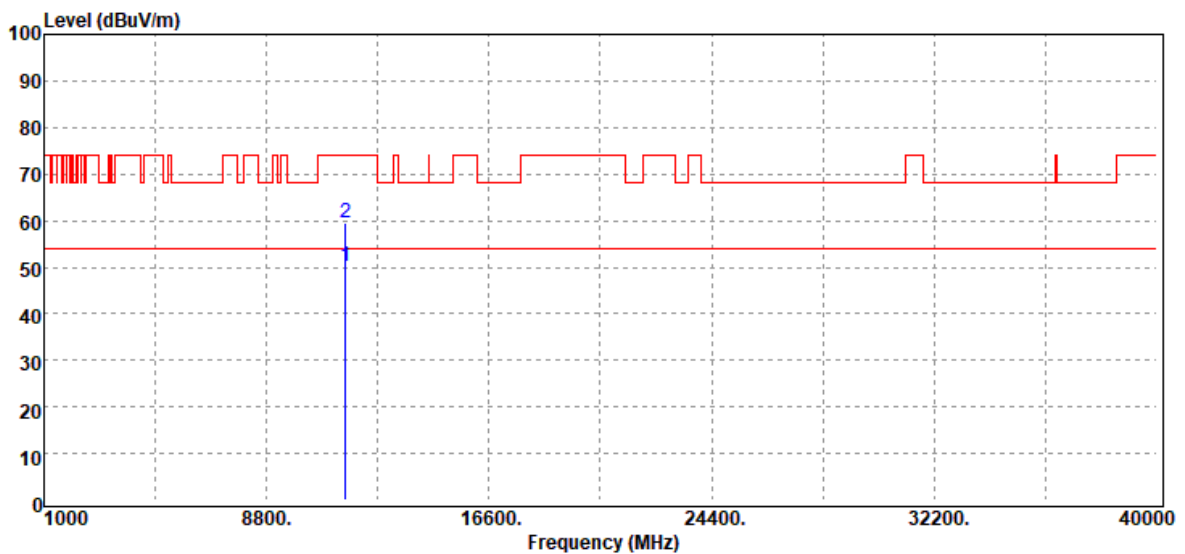

Frequency (MHz)	Reading (dBuV)	Correct Factor (dB/m)	Result (dBuV/m)	Limit (dBuV/m)	Margin (dB)	Remark
11570.00	34.72	15.50	50.22	54.00	-3.78	Average
11570.00	43.97	15.50	59.47	74.00	-14.53	Peak
N/A						

Remark:

1. Measuring frequencies from 1 GHz to the 10th harmonic of highest fundamental frequency.



Report No.: T190315W01-RP4

Test Mode	IEEE 802.11a / 5825 MHz	Temp/Hum	28.2(°C)/ 50%RH
Test Item	Harmonic	Test Date	July 12, 2019
Polarize	Vertical	Test Engineer	Dally Hong
Detector	Peak and Average		

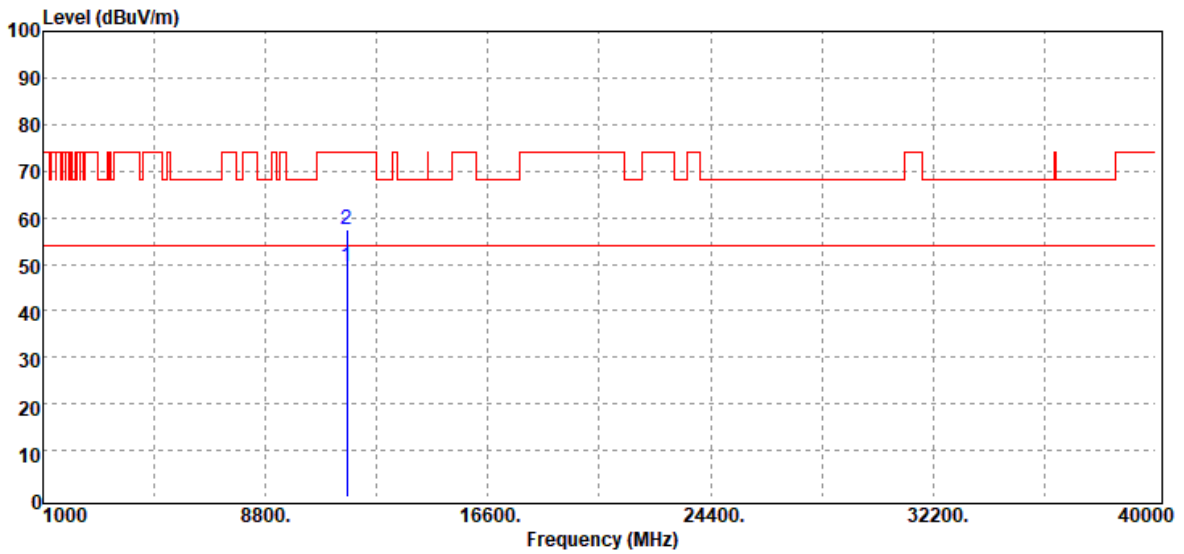

Frequency (MHz)	Reading (dBuV)	Correct Factor (dB/m)	Result (dBuV/m)	Limit (dBuV/m)	Margin (dB)	Remark
11650.00	34.00	15.53	49.53	54.00	-4.47	Average
11650.00	42.02	15.53	57.55	74.00	-16.45	Peak
N/A						

Remark:

1. Measuring frequencies from 1 GHz to the 10th harmonic of highest fundamental frequency.



Report No.: T190315W01-RP4

Test Mode	IEEE 802.11a / 5825 MHz	Temp/Hum	28.2(°C)/ 50%RH
Test Item	Harmonic	Test Date	July 12, 2019
Polarize	Horizontal	Test Engineer	Dally Hong
Detector	Peak and Average		

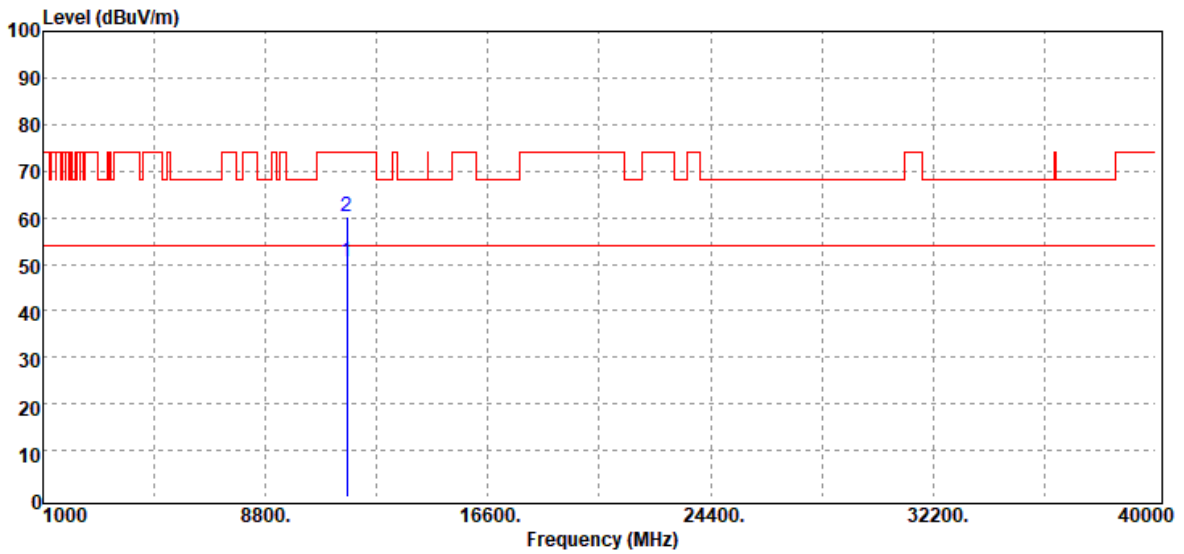

Frequency (MHz)	Reading (dBuV)	Correct Factor (dB/m)	Result (dBuV/m)	Limit (dBuV/m)	Margin (dB)	Remark
11650.00	35.14	15.53	50.67	54.00	-3.33	Average
11650.00	44.83	15.53	60.36	74.00	-13.64	Peak
N/A						

Remark:

1. Measuring frequencies from 1 GHz to the 10th harmonic of highest fundamental frequency.

Test Mode	IEEE 802.11n 20 MHz / 5745 MHz	Temp/Hum	28.2(°C)/ 50%RH
Test Item	Harmonic	Test Date	July 12, 2019
Polarize	Vertical	Test Engineer	Dally Hong
Detector	Peak and Average		

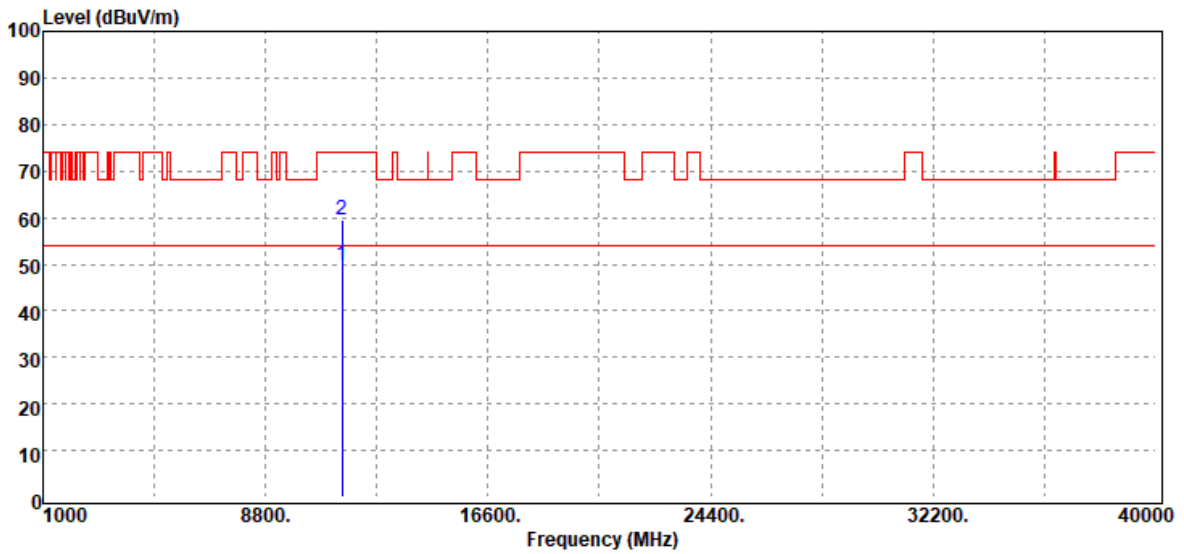

Frequency (MHz)	Reading (dBuV)	Correct Factor (dB/m)	Result (dBuV/m)	Limit (dBuV/m)	Margin (dB)	Remark
11490.00	34.32	15.57	49.89	54.00	-4.11	Average
11490.00	43.90	15.57	59.47	74.00	-14.53	Peak
N/A						

Remark:

1. Measuring frequencies from 1 GHz to the 10th harmonic of highest fundamental frequency.



Report No.: T190315W01-RP4

Test Mode	IEEE 802.11n 20 MHz / 5745 MHz	Temp/Hum	28.2(°C)/ 50%RH
Test Item	Harmonic	Test Date	July 12, 2019
Polarize	Horizontal	Test Engineer	Dally Hong
Detector	Peak and Average		

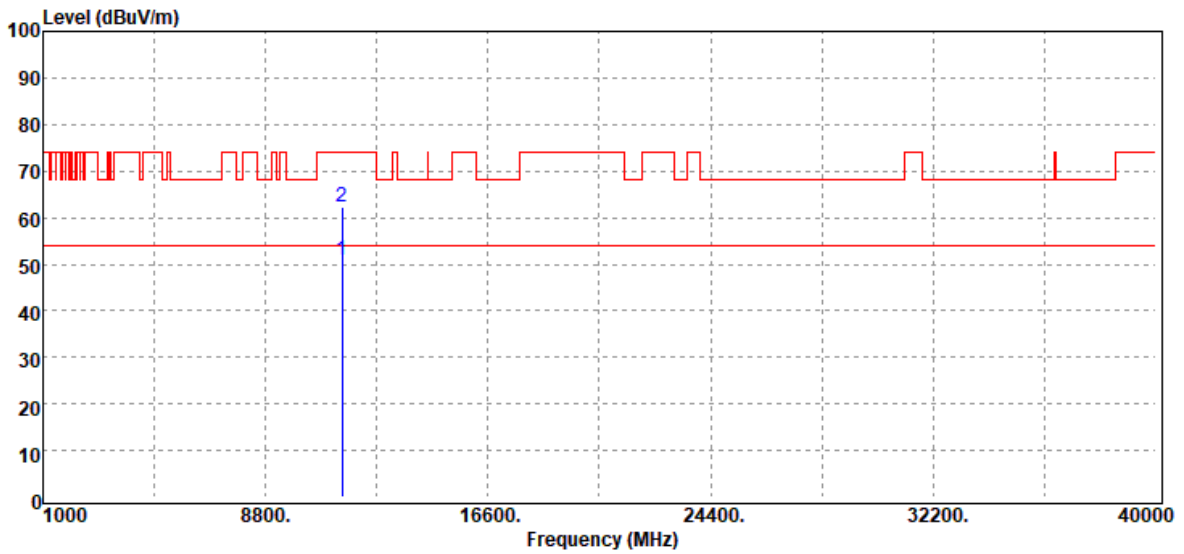

Frequency (MHz)	Reading (dBuV)	Correct Factor (dB/m)	Result (dBuV/m)	Limit (dBuV/m)	Margin (dB)	Remark
11490.00	35.23	15.57	50.80	54.00	-3.20	Average
11490.00	46.78	15.57	62.35	74.00	-11.65	Peak
N/A						

Remark:

- Measuring frequencies from 1 GHz to the 10th harmonic of highest fundamental frequency.

Test Mode	IEEE 802.11n 20 MHz/ 5785 MHz	Temp/Hum	28.2(°C)/ 50%RH
Test Item	Harmonic	Test Date	July 12, 2019
Polarize	Vertical	Test Engineer	Dally Hong
Detector	Peak and Average		

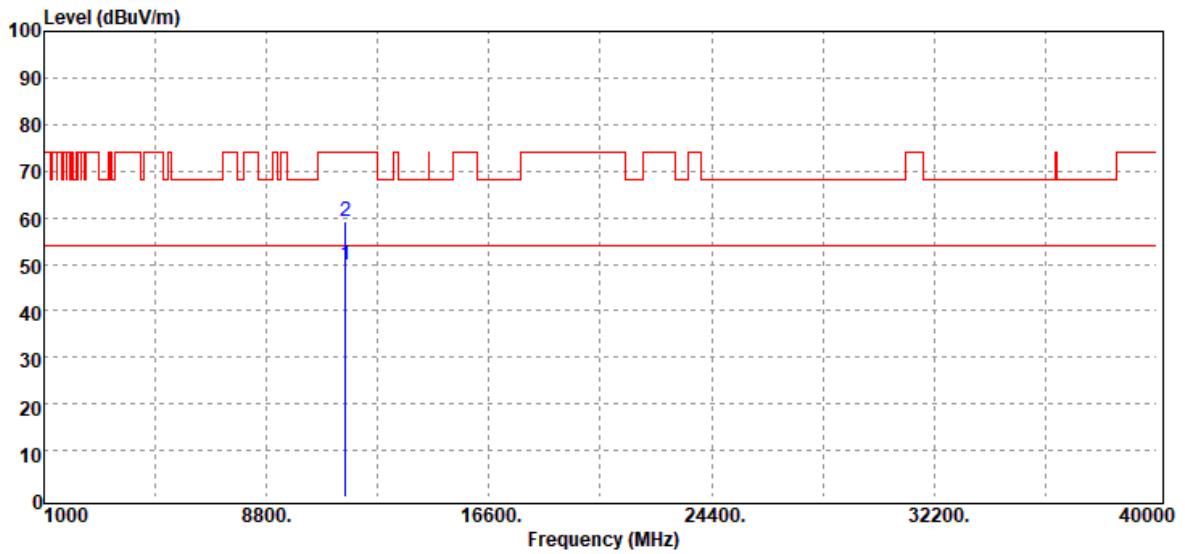

Frequency (MHz)	Reading (dBuV)	Correct Factor (dB/m)	Result (dBuV/m)	Limit (dBuV/m)	Margin (dB)	Remark
11570.00	34.37	15.50	49.87	54.00	-4.13	Average
11570.00	43.65	15.50	59.15	74.00	-14.85	Peak
N/A						

Remark:

- Measuring frequencies from 1 GHz to the 10th harmonic of highest fundamental frequency.

Test Mode	IEEE 802.11n 20 MHz/ 5785 MHz	Temp/Hum	28.2(°C)/ 50%RH
Test Item	Harmonic	Test Date	July 12, 2019
Polarize	Horizontal	Test Engineer	Dally Hong
Detector	Peak and Average		

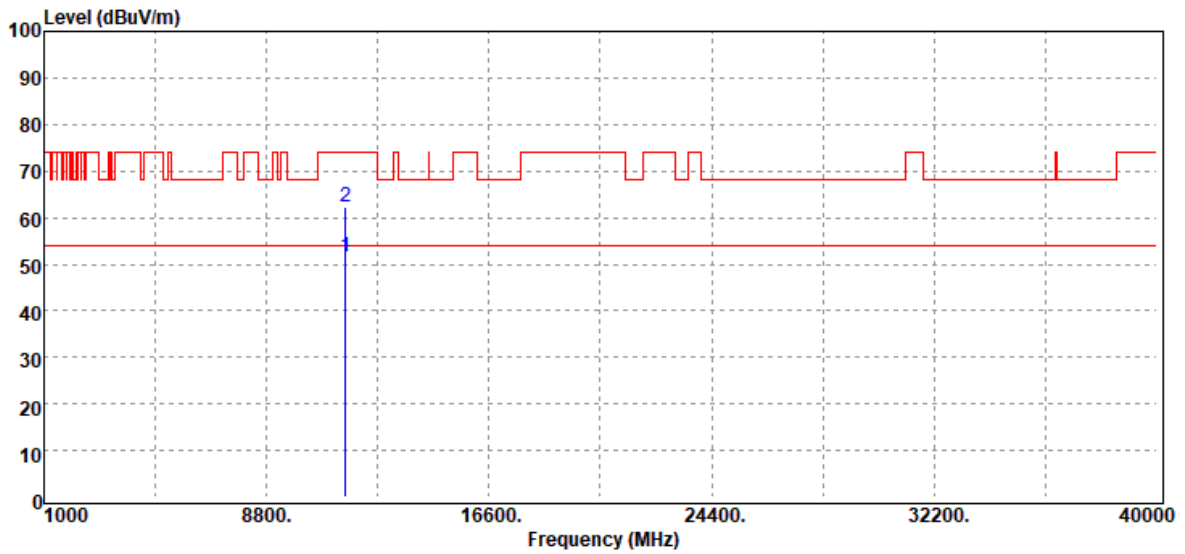

Frequency (MHz)	Reading (dBuV)	Correct Factor (dB/m)	Result (dBuV/m)	Limit (dBuV/m)	Margin (dB)	Remark
11570.00	35.96	15.50	51.46	54.00	-2.54	Average
11570.00	46.81	15.50	62.31	74.00	-11.69	Peak
N/A						

Remark:

1. Measuring frequencies from 1 GHz to the 10th harmonic of highest fundamental frequency.

Test Mode	IEEE 802.11n 20 MHz/ 5825 MHz	Temp/Hum	28.2(°C)/ 50%RH
Test Item	Harmonic	Test Date	July 12, 2019
Polarize	Vertical	Test Engineer	Dally Hong
Detector	Peak and Average		

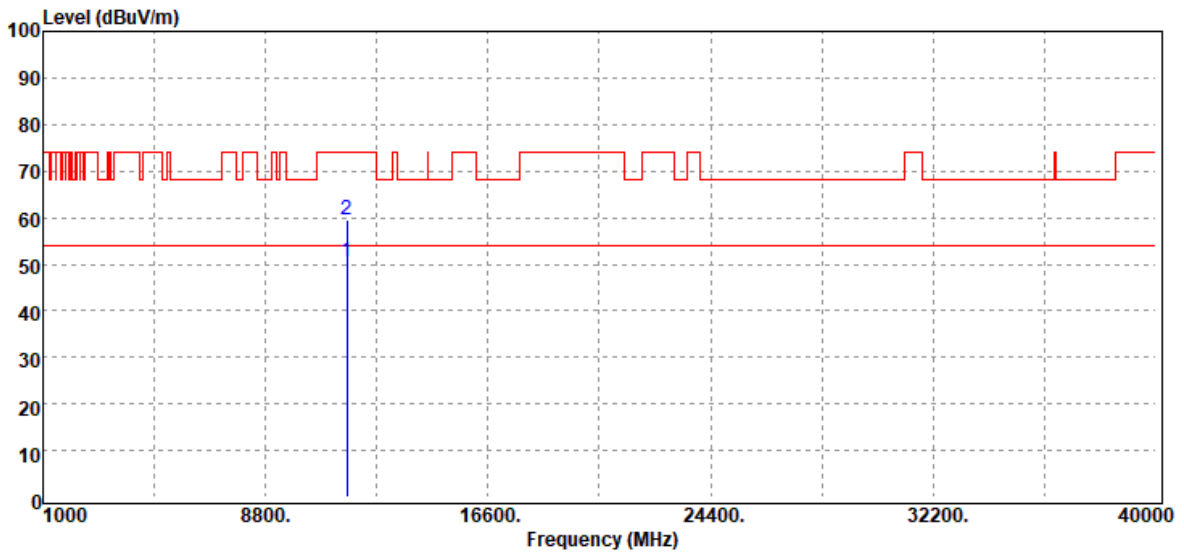

Frequency (MHz)	Reading (dBuV)	Correct Factor (dB/m)	Result (dBuV/m)	Limit (dBuV/m)	Margin (dB)	Remark
11650.00	35.10	15.53	50.63	54.00	-3.37	Average
11650.00	44.13	15.53	59.66	74.00	-14.34	Peak
N/A						

Remark:

1. Measuring frequencies from 1 GHz to the 10th harmonic of highest fundamental frequency.

Test Mode	IEEE 802.11n 20 MHz/ 5825 MHz	Temp/Hum	28.2(°C)/ 50%RH
Test Item	Harmonic	Test Date	July 12, 2019
Polarize	Horizontal	Test Engineer	Dally Hong
Detector	Peak and Average		

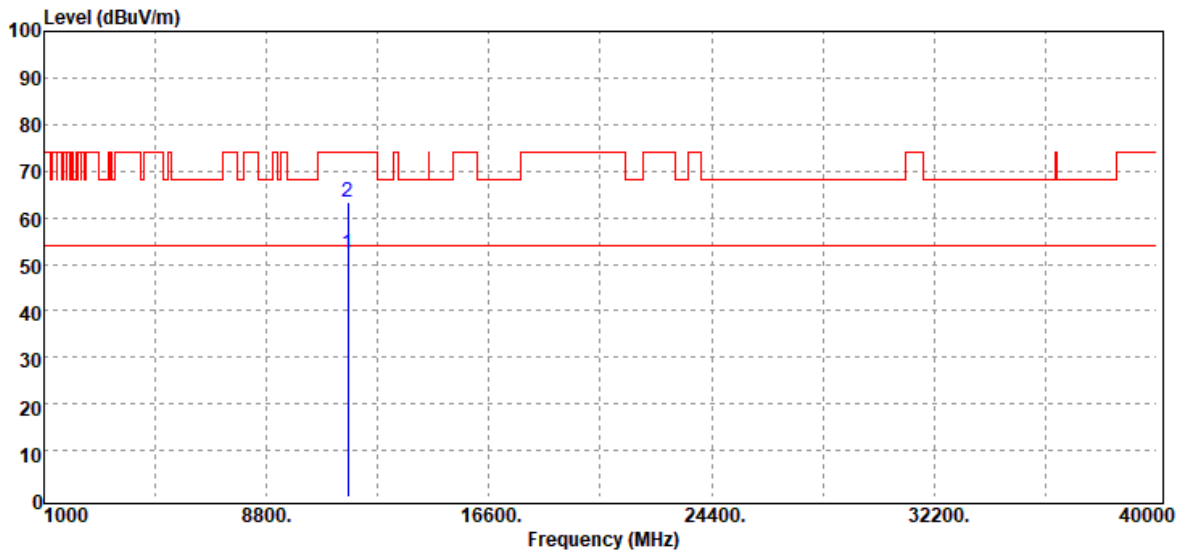

Frequency (MHz)	Reading (dBuV)	Correct Factor (dB/m)	Result (dBuV/m)	Limit (dBuV/m)	Margin (dB)	Remark
11650.00	36.86	15.53	52.39	54.00	-1.61	Average
11650.00	47.94	15.53	63.47	74.00	-10.53	Peak
N/A						

Remark:

1. Measuring frequencies from 1 GHz to the 10th harmonic of highest fundamental frequency.

Test Mode	IEEE 802.11n 40 MHz/ 5755 MHz	Temp/Hum	28.2(°C)/ 50%RH
Test Item	Harmonic	Test Date	July 12, 2019
Polarize	Vertical	Test Engineer	Dally Hong
Detector	Peak and Average		

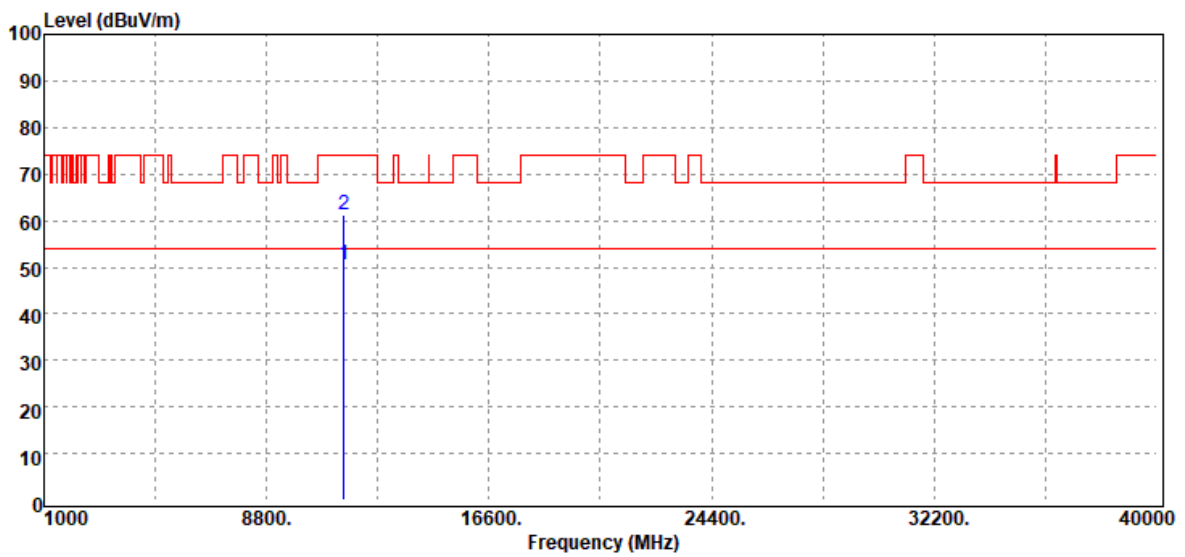

Frequency (MHz)	Reading (dBuV)	Correct Factor (dB/m)	Result (dBuV/m)	Limit (dBuV/m)	Margin (dB)	Remark
11510.00	35.21	15.35	50.56	54.00	-3.44	Average
11510.00	45.75	15.35	61.10	74.00	-12.90	Peak
N/A						

Remark:

- Measuring frequencies from 1 GHz to the 10th harmonic of highest fundamental frequency.

Test Mode	IEEE 802.11n 40 MHz/ 5755 MHz	Temp/Hum	28.2(°C)/ 50%RH
Test Item	Harmonic	Test Date	July 12, 2019
Polarize	Horizontal	Test Engineer	Dally Hong
Detector	Peak and Average		

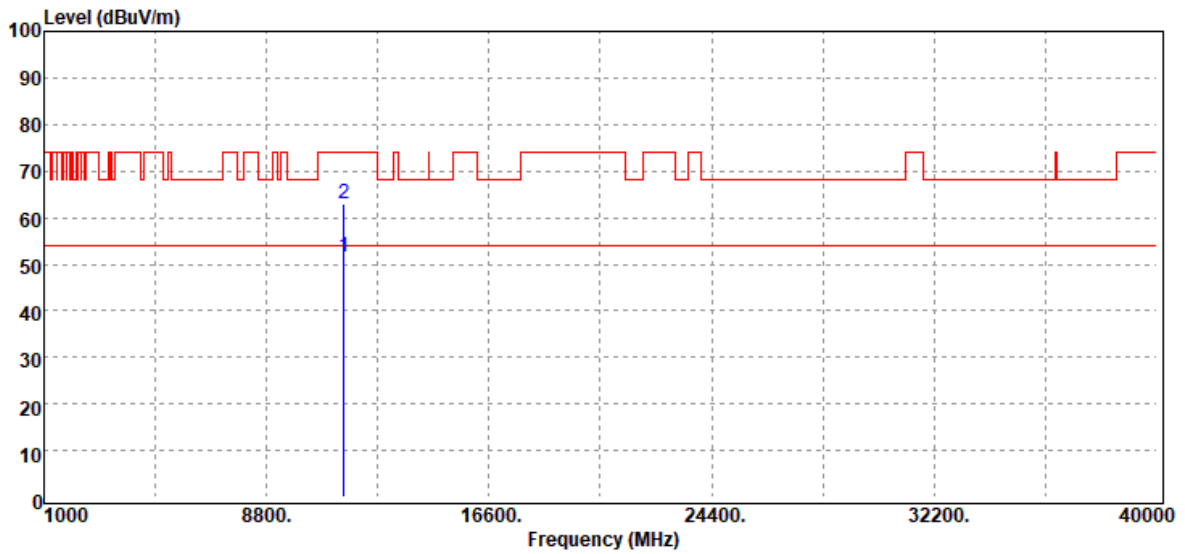

Frequency (MHz)	Reading (dBuV)	Correct Factor (dB/m)	Result (dBuV/m)	Limit (dBuV/m)	Margin (dB)	Remark
11510.00	36.21	15.35	51.56	54.00	-2.44	Average
11510.00	47.69	15.35	63.04	74.00	-10.96	Peak
N/A						

Remark:

1. Measuring frequencies from 1 GHz to the 10th harmonic of highest fundamental frequency.

Test Mode	IEEE 802.11n 40 MHz/ 5795 MHz	Temp/Hum	28.2(°C)/ 50%RH
Test Item	Harmonic	Test Date	July 12, 2019
Polarize	Vertical	Test Engineer	Dally Hong
Detector	Peak and Average		

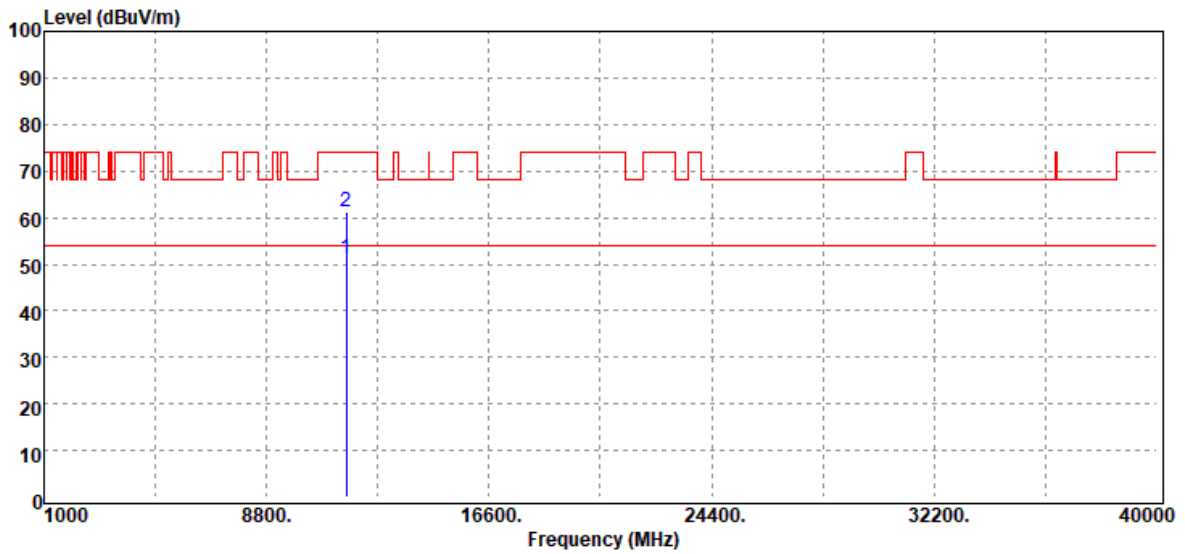

Frequency (MHz)	Reading (dBuV)	Correct Factor (dB/m)	Result (dBuV/m)	Limit (dBuV/m)	Margin (dB)	Remark
11600.00	35.63	15.67	51.30	54.00	-2.70	Average
11600.00	45.56	15.67	61.23	74.00	-12.77	Peak
N/A						

Remark:

- Measuring frequencies from 1 GHz to the 10th harmonic of highest fundamental frequency.



Report No.: T190315W01-RP4

Page: 174 / 192
Rev.: 01

Test Mode	IEEE 802.11n 40 MHz/ 5795 MHz	Temp/Hum	28.2(°C)/ 50%RH
Test Item	Harmonic	Test Date	July 12, 2019
Polarize	Horizontal	Test Engineer	Dally Hong
Detector	Peak and Average		

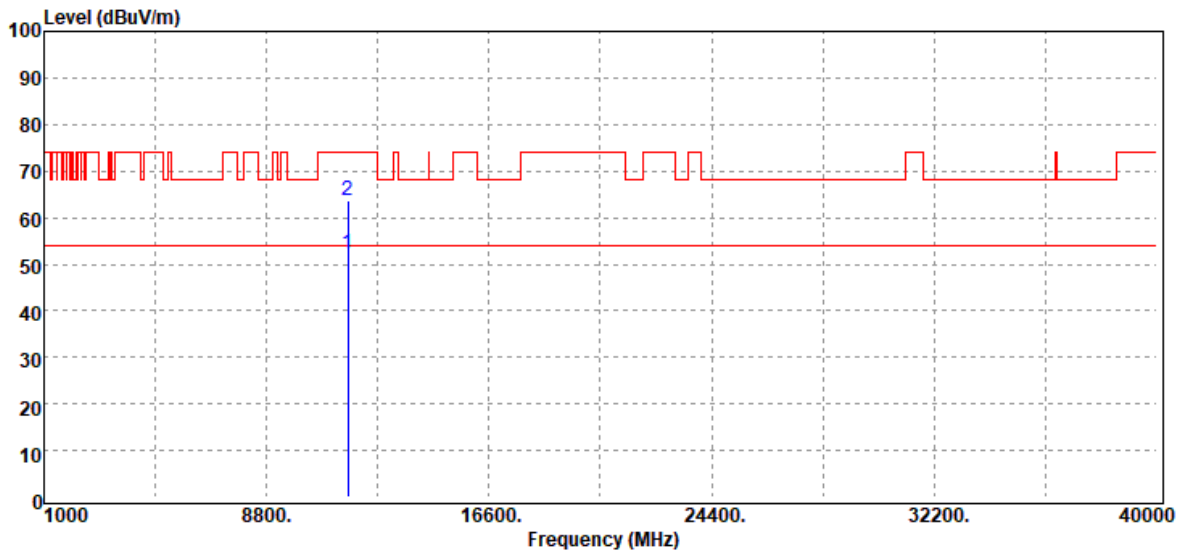

Frequency (MHz)	Reading (dBuV)	Correct Factor (dB/m)	Result (dBuV/m)	Limit (dBuV/m)	Margin (dB)	Remark
11640.00	36.82	15.56	52.38	54.00	-1.62	Average
11640.00	48.22	15.56	63.78	74.00	-10.22	Peak
N/A						

Remark:

1. Measuring frequencies from 1 GHz to the 10th harmonic of highest fundamental frequency.



Report No.: T190315W01-RP4

Page: 175 / 192
Rev.: 01

Test Mode	IEEE 802.11ac VHT80/ 5775 MHz	Temp/Hum	28.2(°C)/ 50%RH
Test Item	Harmonic	Test Date	July 12, 2019
Polarize	Vertical	Test Engineer	Dally Hong
Detector	Peak and Average		

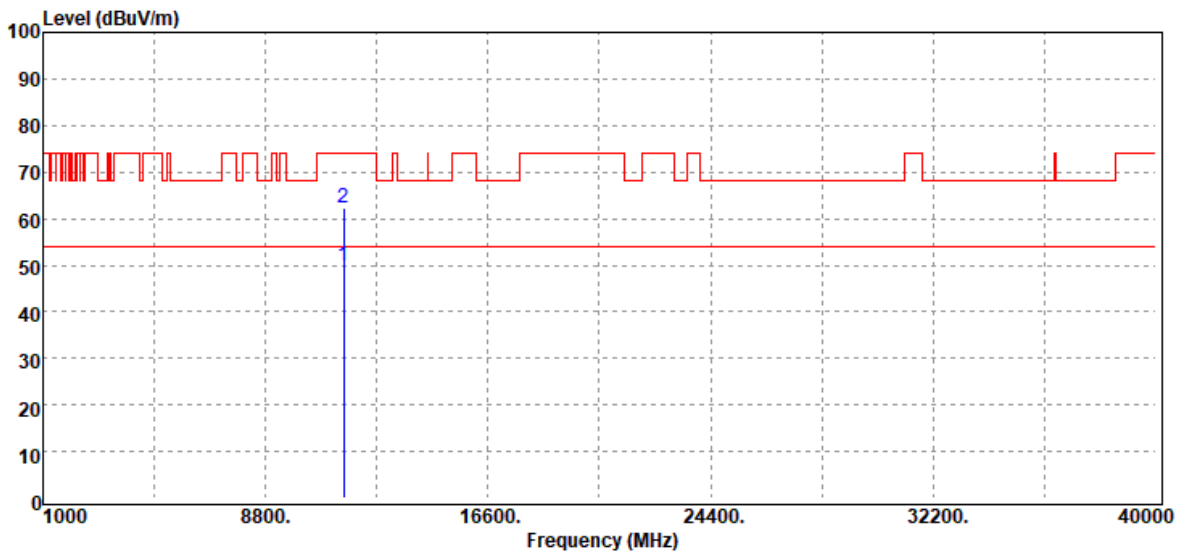

Frequency (MHz)	Reading (dBuV)	Correct Factor (dB/m)	Result (dBuV/m)	Limit (dBuV/m)	Margin (dB)	Remark
11550.00	34.38	15.39	49.77	54.00	-4.23	Average
11550.00	46.73	15.39	62.12	74.00	-11.88	Peak
N/A						

Remark:

- Measuring frequencies from 1 GHz to the 10th harmonic of highest fundamental frequency.

Test Mode	IEEE 802.11ac VHT80/ 5775 MHz	Temp/Hum	28.2(°C)/ 50%RH
Test Item	Harmonic	Test Date	July 12, 2019
Polarize	Horizontal	Test Engineer	Dally Hong
Detector	Peak and Average		

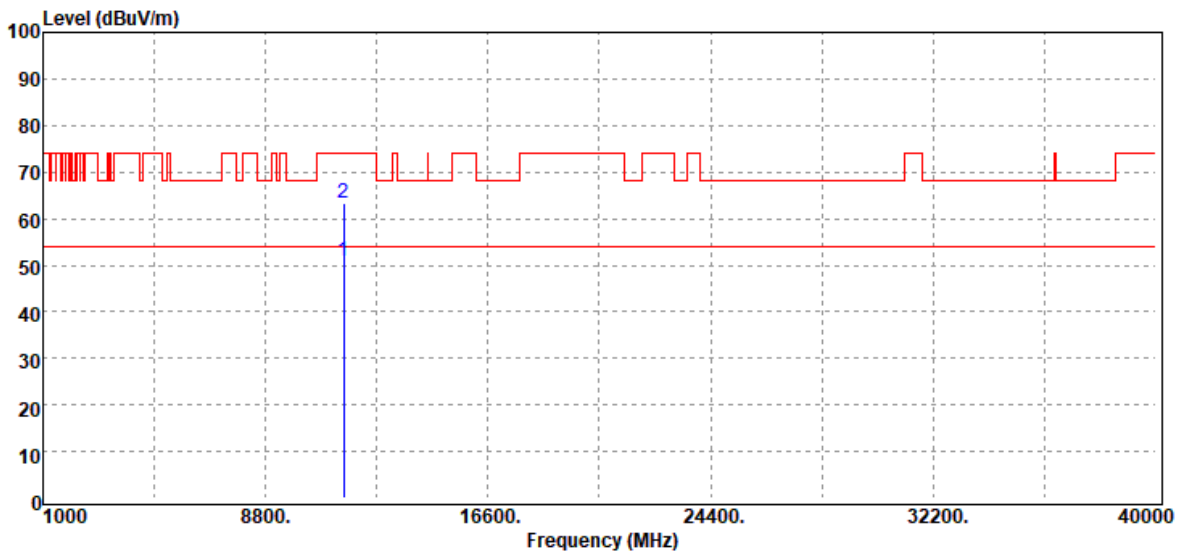

Frequency (MHz)	Reading (dBuV)	Correct Factor (dB/m)	Result (dBuV/m)	Limit (dBuV/m)	Margin (dB)	Remark
11550.00	35.61	15.39	51.00	54.00	-3.00	Average
11550.00	47.91	15.39	63.30	74.00	-10.70	Peak
N/A						

Remark:

- Measuring frequencies from 1 GHz to the 10th harmonic of highest fundamental frequency.

Report No.: T190315W01-RP4

4.6 FREQUENCY STABILITY

4.6.1 Test Limit

According to §15.407(g) manufacturers of U-NII devices are responsible for ensuring frequency stability such that an emission is maintained within the band of operation under all conditions of normal operation as specified in the operational description.

4.6.2 Test Procedure

The equipment under test was connected to an external AC or DC power supply and input rated voltage. RF output was connected to a frequency counter or spectrum analyzer via feed through attenuators. The EUT was placed inside the temperature chamber. Set the spectrum analyzer RBW low enough to obtain the desired frequency resolution and measure EUT 20°C operating frequency as reference frequency. Turn EUT off and set the chamber temperature to 0°C. After the temperature stabilized for approximately 30 minutes recorded the frequency. Repeat step measure with 10°C increased per stage until the highest temperature of +50°C reached.

4.6.3 Test Setup

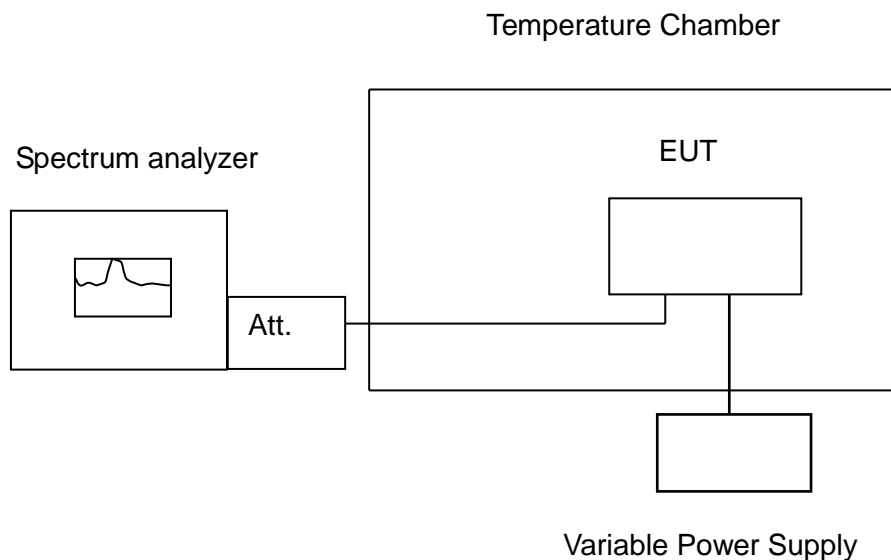

4.6.4 Test Result

Temp. (°C)	Voltage (V)	Measured Frequency	5180				Limit				Result
			Time (min)				20ppm				
Operating Frequency:		0 min	2 min	5 min	10 min	0 min	2 min	5 min	10 min		
50	5	5180.03647	5180.04081	5180.04211	5180.04645	7.0405	7.8784	8.1293	8.9672	Pass	
40	5	5180.01346	5180.01606	5180.02041	5180.02258	2.5985	3.1004	3.9402	4.3591	Pass	
30	5	5180.00260	5180.00260	5180.00217	5180.00391	0.5019	0.5019	0.4189	0.7548	Pass	
20	5	5179.99566	5179.99522	5179.99609	5179.99653	-0.8378	-0.9228	-0.7548	-0.6699	Pass	
10	5	5179.99957	5179.99826	5179.99740	5179.99696	-0.0830	-0.3359	-0.5019	-0.5869	Pass	
0	5	5180.00825	5180.00347	5180.00260	5180.00174	1.5927	0.6699	0.5019	0.3359	Pass	

Temp. (°C)	Voltage (V)	Measured Frequency	5180				Limit				Result
			Time (min)				20ppm				
Operating Frequency:		0 min	2 min	5 min	10 min	0 min	2 min	5 min	10 min		
25	4.25	5179.999130	5179.998260	5179.99826	5179.99783	-0.1680	-0.3359	-0.3359	-0.4189	Pass	
25	5	5179.996960	5179.99783	5179.99826	5179.996960	-0.5869	-0.4189	-0.3359	-0.5869	Pass	
25	5.75	5179.998260	5179.99783	5179.998260	5179.99870	-0.3359	-0.4189	-0.3359	-0.2510	Pass	

Temp. (°C)	Voltage (V)	Measured Frequency	5260				Limit				Result
			Time (min)				20ppm				
Operating Frequency:		0 min	2 min	5 min	10 min	0 min	2 min	5 min	10 min		
50	5	5260.04211	5260.04689	5260.04949	5260.05384	8.0057	8.9144	9.4087	10.2357	Pass	
40	5	5260.01259	5260.01563	5260.01997	5260.02127	2.3935	2.9715	3.7966	4.0437	Pass	
30	5	5260.00043	5260.00174	5260.00217	5260.00304	0.0817	0.3308	0.4125	0.5779	Pass	
20	5	5259.99566	5259.99522	5259.99175	5259.99826	-0.8251	-0.9087	-1.5684	-0.3308	Pass	
10	5	5259.99783	5259.99653	5259.99609	5259.99305	-0.4125	-0.6597	-0.7433	-1.3213	Pass	
0	5	5259.99957	5259.99522	5260.01085	5260.00608	-0.0817	-0.9087	2.0627	1.1559	Pass	

Temp. (°C)	Voltage (V)	Measured Frequency	5260				Limit				Result
			Time (min)				20ppm				
Operating Frequency:		0 min	2 min	5 min	10 min	0 min	2 min	5 min	10 min		
25	4.25	5259.99783	5259.99826	5259.99870	5259.99957	-0.4125	-0.3308	-0.2471	-0.0817	Pass	
25	5	5259.99175	5259.99522	5259.99479	5259.99566	-1.5684	-0.9087	-0.9905	-0.8251	Pass	
25	5.75	5259.99609	5259.99653	5259.99696	5259.99740	-0.7433	-0.6597	-0.5779	-0.4943	Pass	



Temp. (°C)	Voltage (V)	Measured Frequency	5500				Limit				Result
			Time (min)				20ppm				
Operating Frequency:		0 min	2 min	5 min	10 min	0 min	2 min	5 min	10 min		
50	5	5500.05253	5500.05427	5500.05470	5500.05514	9.5509	9.8673	9.9455	10.0255	Pass	
40	5	5500.01172	5500.01389	5500.01693	5500.01737	2.1309	2.5255	3.0782	3.1582	Pass	
30	5	5500.00130	5500.00174	5500.00260	5500.00391	0.2364	0.3164	0.4727	0.7109	Pass	
20	5	5499.99783	5499.99566	5499.99883	5499.99479	-0.3945	-0.7891	-0.2135	-0.9473	Pass	
10	5	5499.99696	5499.99609	5499.99566	5499.99609	-0.5527	-0.7109	-0.7891	-0.7109	Pass	
0	5	5500.01433	5500.01476	5500.01693	5500.01823	2.6055	2.6836	3.0782	3.3145	Pass	

Temp. (°C)	Voltage (V)	Measured Frequency	5500				Limit				Result
			Time (min)				20ppm				
Operating Frequency:		0 min	2 min	5 min	10 min	0 min	2 min	5 min	10 min		
25	4.25	5499.99870	5499.99826	5499.99783	5499.99826	-0.2364	-0.3164	-0.3945	-0.3164	Pass	
25	5	5499.99479	5499.99566	5499.99740	5499.99783	-0.9473	-0.7891	-0.4727	-0.3945	Pass	
25	5.75	5499.99826	5499.99783	5499.99783	5499.99883	-0.3164	-0.3945	-0.3945	-0.2135	Pass	

Temp. (°C)	Voltage (V)	Measured Frequency	5745				Limit				Result
			Time (min)				20ppm				
Operating Frequency:		0 min	2 min	5 min	10 min	0 min	2 min	5 min	10 min		
50	5	5745.05687	5745.05948	5745.06252	5745.06295	9.8990	10.3534	10.8825	10.9574	Pass	
40	5	5745.01302	5745.01650	5745.01997	5745.02214	2.2663	2.8721	3.4761	3.8538	Pass	
30	5	5745.00304	5745.00347	5745.00478	5745.00521	0.5292	0.6040	0.8320	0.9069	Pass	
20	5	5744.99870	5744.99479	5744.99566	5744.99609	-0.2263	-0.9069	-0.7554	-0.6806	Pass	
10	5	5744.99566	5744.99609	5744.99522	5744.99566	-0.7554	-0.6806	-0.8320	-0.7554	Pass	
0	5	5745.01042	5745.01172	5745.00391	5745.00174	1.8138	2.0400	0.6806	0.3029	Pass	

Temp. (°C)	Voltage (V)	Measured Frequency	5745				Limit				Result
			Time (min)				20ppm				
Operating Frequency:		0 min	2 min	5 min	10 min	0 min	2 min	5 min	10 min		
25	4.25	5744.99783	5744.99957	5744.99826	5744.99957	-0.3777	-0.0748	-0.3029	-0.0748	Pass	
25	5	5744.99826	5744.99870	5744.99826	5744.99826	-0.3029	-0.2263	-0.3029	-0.3029	Pass	
25	5.75	5744.99870	5744.99783	5744.99826	5744.99913	-0.2263	-0.3777	-0.3029	-0.1514	Pass	

Report No.: T190315W01-RP4

4.7 DYNAMIC FREQUENCY SELECTION

4.7.1 Test Limit

FCC according to §15.407 (h), KDB 905462 D02 "compliance measurement procedures for unlicensed-national information infrastructure devices operating in the 5250-5350 MHz and 5470-5725 MHz bands incorporating dynamic frequency selection". and KDB 905462 D03 " U-NII client devices without radar detection capability.

IC according RSS-247 section 6.3, and it harmonized with FCC Part 15 DFS rules.

The EIRP refer section 4.3 output power measurement in this report.

Table 1: Applicability of DFS requirements prior to use of a channel

Requirement	Operational Mode		
	Master	Client (without radar detection)	Client(with radar detection)
Non-Occupancy Period	Yes	Not required	Yes
DFS Detection Threshold	Yes	Not required	Yes
Channel Availability Check Time	Yes	Not required	Not required
U-NII Detection Bandwidth	Yes	Not required	Yes

Table 2: Applicability of DFS requirements during normal operation

Requirement	Operational Mode	
	Master Device or Client with Radar Detection	Client Without Radar Detection
DFS Detection Threshold	Yes	Not required
Channel Closing Transmission Time	Yes	Yes
Channel Move Time	Yes	Yes
U-NII Detection Bandwidth	Yes	Not required

Additional requirements for devices with multiple bandwidth mods	Master Device or Client with Radar Detection	Client Without Radar Detection
U-NII Detection Bandwidth and Statistical Performance Check	All BW modes must be tested	Not required
Channel Move Time and Channel Closing Transmission Time	Test using widest BW mode available	Test using the widest BW mode available for the link
All other tests	Any single BW mode	Not required

Note: Frequencies selected for statistical performance check (Section 7.8.4) should include several frequencies within the radar detection bandwidth and frequencies near the edge of the radar detection bandwidth. For 802.11 devices it is suggested to select frequencies in each of the bonded 20 MHz channels and the channel center frequency.

Report No.: T190315W01-RP4

Table 3: Interference Threshold values, Master or Client incorporating In-Service

Maximum Transmit Power	Value (See Notes 1, 2, and 3)
EIRP \geq 200 milliwatt	-64 dBm
EIRP < 200 milliwatt and power spectral density < 10 dBm/MHz	-62 dBm
EIRP < 200 milliwatt that do not meet the power spectral density requirement	-64 dBm

Note 1: This is the level at the input of the receiver assuming a 0 dBi receive antenna.
Note 2: Throughout these test procedures an additional 1 dB has been added to the amplitude of the test transmission waveforms to account for variations in measurement equipment. This will ensure that the test signal is at or above the detection threshold level to trigger a DFS response.
Note 3: EIRP is based on the highest antenna gain. For MIMO devices refer to KDB Publication 662911 D01.

Table 4: DFS Response requirement values

Parameter	Value
Non-occupancy period	Minimum 30 minutes
Channel Availability Check Time	60 seconds
Channel Move Time	10 seconds See Note 1.
Channel Closing Transmission Time	200 milliseconds + an aggregate of 60 milliseconds over remaining 10 second period. See Notes 1 and 2.
U-NII Detection Bandwidth	Minimum 100% of the U-NII 99% transmission power bandwidth. See Note 3.

Note 1: Channel Move Time and the Channel Closing Transmission Time should be performed with Radar Type 0. The measurement timing begins at the end of the Radar Type 0 burst.
Note 2: The Channel Closing Transmission Time is comprised of 200 milliseconds starting at the beginning of the Channel Move Time plus any additional intermittent control signals required to facilitate a Channel move (an aggregate of 60 milliseconds) during the remainder of the 10 second period. The aggregate duration of control signals will not count quiet periods in between transmissions.
Note 3: During the U-NII Detection Bandwidth detection test, radar type 0 should be used. For each frequency step the minimum percentage of detection is 90 percent. Measurements are performed with no data traffic.

Report No.: T190315W01-RP4

Table 5 – Short Pulse Radar Test Waveforms

Radar Type	Pulse Width (μsec)	PRI (μsec)	Number of Pulses	Minimum Percentage of Successful Detection	Minimum Number of Trials
0	1	1428	18	See Note 1	
1	1	Test A: 15 unique PRI values randomly selected from the list of 23 PRI values in Table 5a	$\text{Roundup} \left\{ \begin{array}{l} \left(\frac{1}{360} \right) \cdot \\ \left(\frac{19 \cdot 10^6}{\text{PRI}_{\mu\text{sec}}} \right) \end{array} \right\}$	60%	30
		Test B: 15 unique PRI values randomly selected within the range of 518-3066 μsec, with a minimum increment of 1 μsec, excluding PRI values selected in Test A			
2	1-5	150-230	23-29	60%	30
3	6-10	200-500	16-18	60%	30
4	11-20	200-500	12-16	60%	30
Aggregate (Radar Types 1-4)				80%	120
Note 1: Short Pulse Radar Type 0 should be used for the detection bandwidth test, channel move time, and channel closing time tests.					

Table 6 – Long Pulse Radar Test Signal

Radar Type	Pulse Width (μsec)	Chirp Width (MHz)	PRI (μsec)	Number of Pulses per Burst	Number of Bursts	Minimum Percentage of Successful Detection	Minimum Number of Trials
5	50-100	5-20	1000-2000	1-3	8-20	80%	30

Table 7 – Frequency Hopping Radar Test Signal

Radar Type	Pulse Width (μsec)	PRI (μsec)	Pulses per Hop	Hopping Rate (kHz)	Hopping Sequence Length (msec)	Minimum Percentage of Successful Detection	Minimum Number of Trials
6	1	333	9	0.333	300	70%	30



Report No.: T190315W01-RP4

Page: 184 / 192
Rev.: 01

4.7.2 Test Procedure

Overview Of EUT With Respect To §15.407 (H) Requirements

The firmware installed in the EUT during testing was:

Firmware Rev: 1030.27.425.2018

The EUT operates over the 5250-5350 MHz range as a Client Device that does not have radar detection capability.

The EUT uses one transmitter connected to two 50-ohm coaxial antenna ports via a diversity switch. Only one antenna port is connected to the test system since the EUT has one antenna only.

The Slave device associated with the EUT during these tests does not have radar detection capability.

WLAN traffic is generated by streaming the video file TestFile.mp2 “6 ½ Magic Hours” from the Master to the Slave in full motion video mode using the media player with the V2.61 Codec package.

The EUT utilizes the 802.11a architecture, with a nominal channel bandwidth of 20 MHz.

The rated output power of the Master unit is < 23dBm (EIRP). Therefore the required interference threshold level is -62 dBm. After correction for antenna gain and procedural adjustments, the required conducted threshold at the antenna port is $-62 + 5 = -57$ dBm.

The calibrated conducted DFS Detection Threshold level is set to -57 dBm. The tested level is lower than the required level hence it provides margin to the limit.

Manufacturer’s Statement Regarding Uniform Channel Spreading

The end product implements an automatic channel selection feature at startup such that operation commences on channels distributed across the entire set of allowed 5GHz channels. This feature will ensure uniform spreading is achieved while avoiding non-allowed channels due to prior radar events.



Report No.: T190315W01-RP4

Page: 185 / 192
Rev.: 01

TEST AND MEASUREMENT SYSTEM

System Overview

The measurement system is based on a conducted test method.

The short pulse and long pulse signal generating system utilizes the NTIA software. The Vector Signal Generator has been validated by the NTIA. The hopping signal generating system utilizes the CCS simulated hopping method and system, which has been validated by the DoD, FCC and NTIA. The software selects waveform parameters from within the bounds of the signal type on a random basis using uniform distribution.

The short pulse types 2, 3 and 4, and the long pulse type 5 parameters are randomized at run-time.

The hopping type 6 pulse parameters are fixed while the hopping sequence is based on the August 2005 NTIA Hopping Frequency List. The initial starting point randomized at run-time and each subsequent starting point is incremented by 475. Each frequency in the 100-length segment is compared to the boundaries of the EUT Detection Bandwidth and the software creates a hopping burst pattern in accordance with Section 7.4.1.3 Method #2 Simulated Frequency Hopping Radar Waveform Generating Subsystem of FCC 06-96 APPENDIX. The frequency of the signal generator is incremented in 1 MHz steps from FL to FH for each successive trial. This incremental sequence is repeated as required to generate a minimum of 30 total trials and to maintain a uniform frequency distribution over the entire Detection Bandwidth.

The signal monitoring equipment consists of a spectrum analyzer set to display 8001 bins on the horizontal axis. The time-domain resolution is 2 msec / bin with a 16 second sweep time, meeting the 10 second short pulse reporting criteria. The aggregate ON time is calculated by multiplying the number of bins above a threshold during a particular observation period by the dwell time per bin, with the analyzer set to peak detection and max hold. The time-domain resolution is 3 msec / bin with a 24 second sweep time, meeting the 22 second long pulse reporting criteria and allowing a minimum of 10 seconds after the end of the long pulse waveform.

Should multiple RF ports be utilized for the Master and/or Slave devices (for example, for diversity or MIMO implementations), 50 ohm termination would be removed from the splitter so that connection can be established between splitter and the Master and/or Slave devices.

Conducted Method System Block Diagram

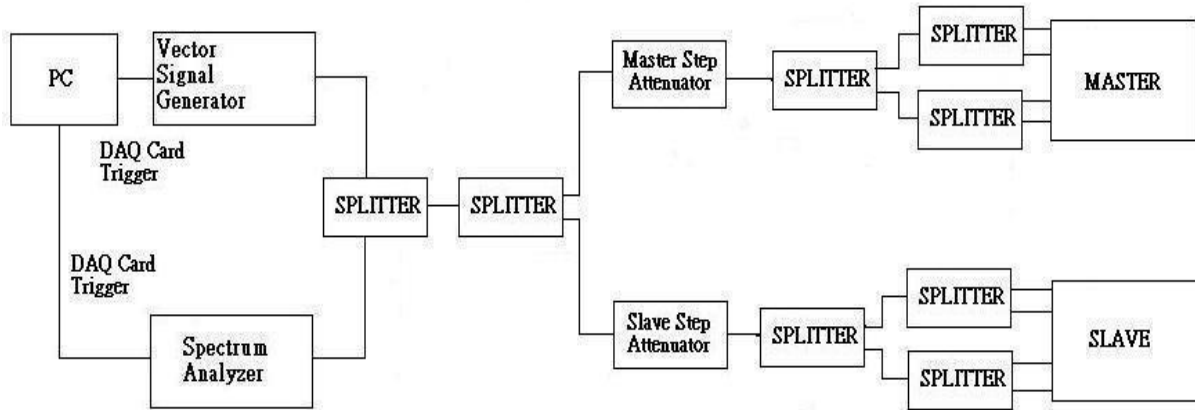



Report No.: T190315W01-RP4

System Calibration

Connect the spectrum analyzer to the test system in place of the master device. Set the signal generator to CW mode. Adjust the amplitude of the signal generator to yield a measured level of -62 dBm on the spectrum analyzer.

Without changing any of the instrument settings, reconnect the spectrum analyzer to the Common port of the Spectrum Analyzer Combiner/Divider and connect a 50 ohm load to the Master Device port of the test system.

Measure the amplitude and calculate the difference from -62 dBm. Adjust the Reference Level Offset of the spectrum analyzer to this difference. Confirm that the signal is displayed at -62 dBm. Readjust the RBW and VBW to 3 MHz, set the span to 10 MHz, and confirm that the signal is still displayed at -62 dBm.

The spectrum analyzer displays the level of the signal generator as received at the antenna ports of the Master Device. The interference detection threshold may be varied from the calibrated value of -62 dBm and the spectrum analyzer will still indicate the level as received by the Master Device.

Set the signal generator to produce a radar waveform, trigger a burst manually and measure the level on the spectrum analyzer. Readjust the amplitude of the signal generator as required so that the peak level of the waveform is at a displayed level equal to the required or desired interference detection threshold. Separate signal generator amplitude settings are determined as required for each radar type.

Adjustment Of Displayed Traffic Level

Establish a link between the Master and Slave, adjusting the Link Step Attenuator as needed to provide a suitable received level at the Master and Slave devices. Stream the video test file to generate WLAN traffic. Confirm that the WLAN traffic level, as displayed on the spectrum analyzer, is at lower amplitude than the radar detection threshold. Confirm that the displayed traffic is from the Master Device. For Master Device testing confirm that the displayed traffic does not include Slave Device traffic. For Slave Device testing confirm that the displayed traffic does not include Master Device traffic.

If a different setting of the Master Step Attenuator is required to meet the above conditions, perform a new System Calibration for the new Master Step Attenuator setting.

4.7.3 Test Setup

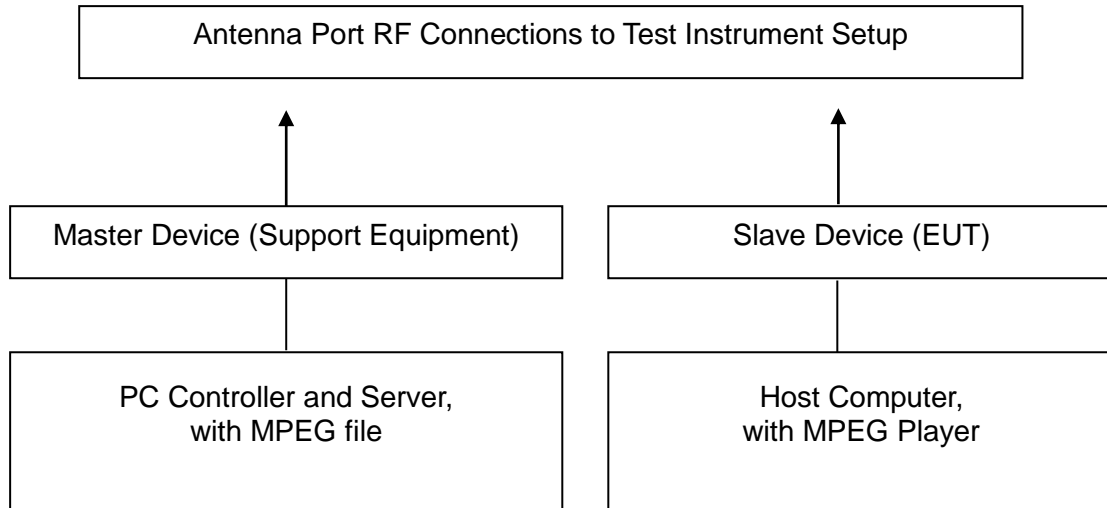



Report No.: T190315W01-RP4

4.7.4 Test Result

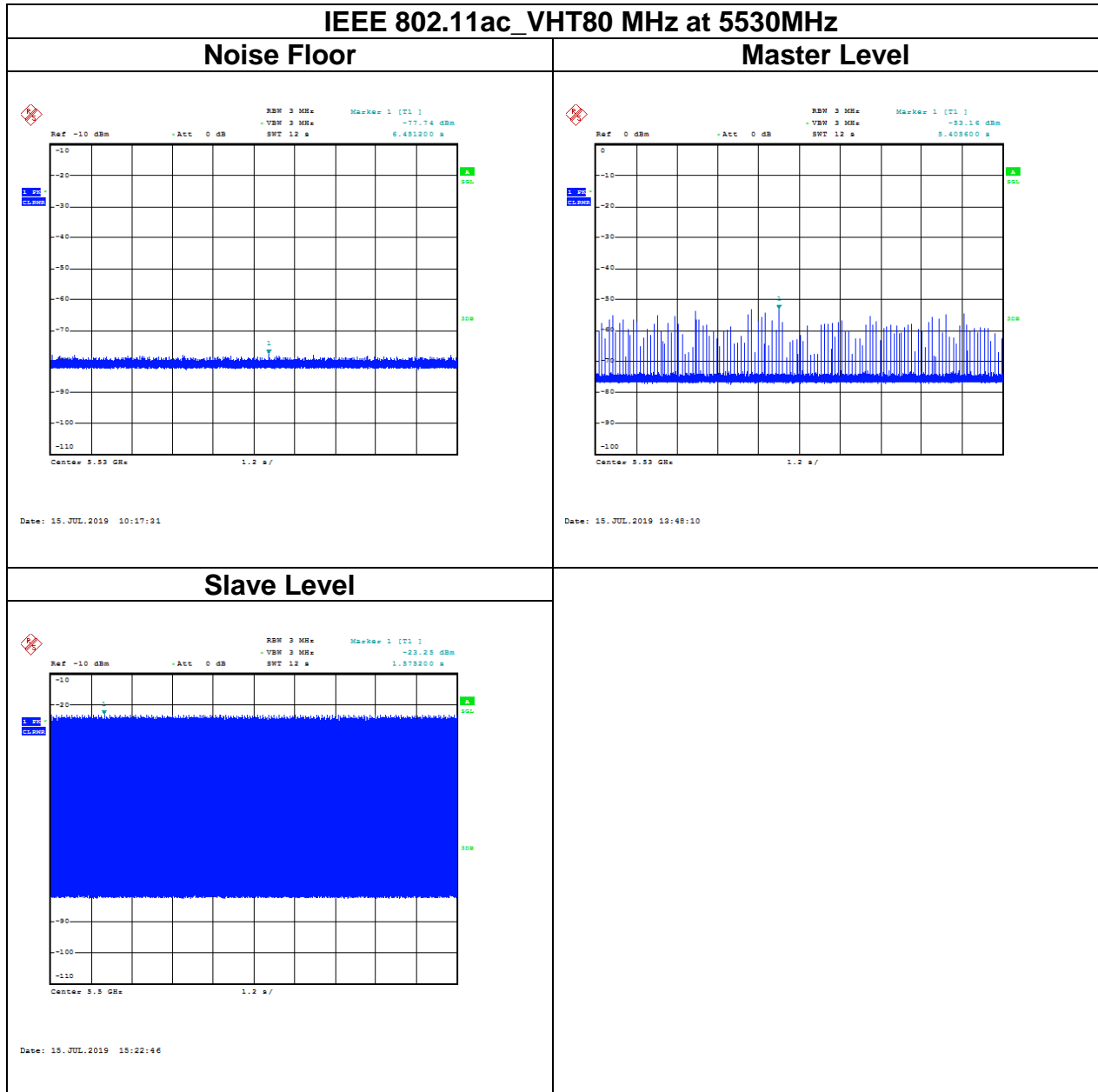



Report No.: T190315W01-RP4

Page: 190 / 192
Rev.: 01

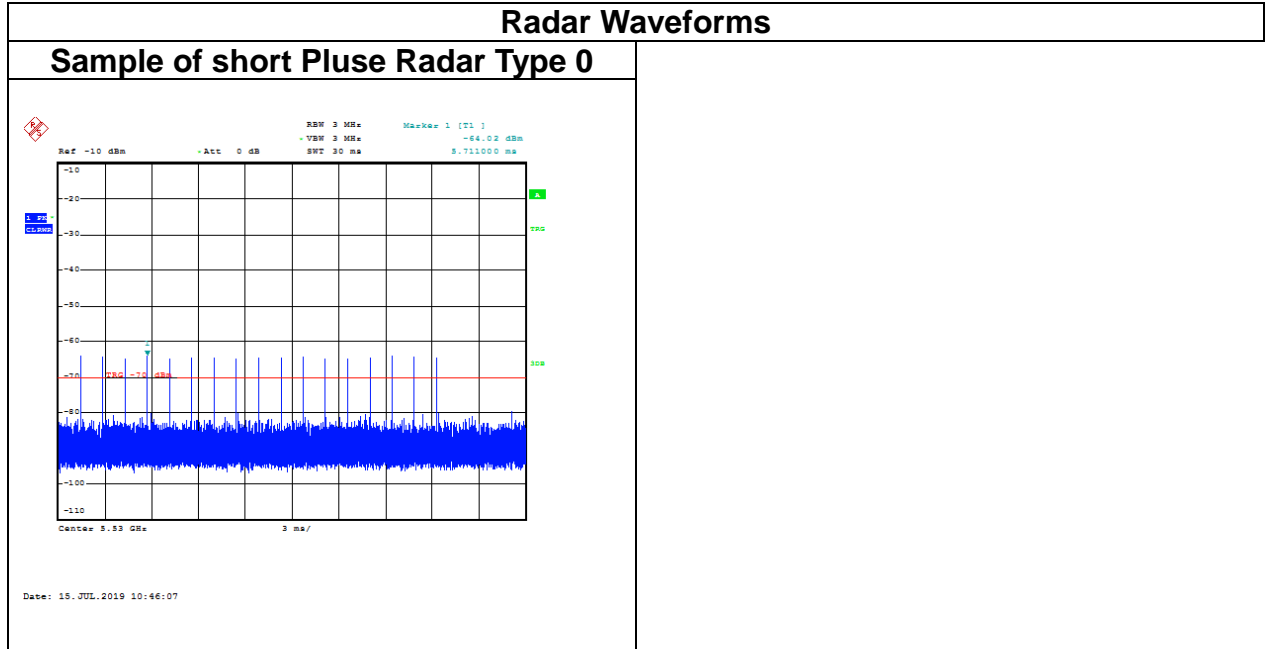



Report No.: T190315W01-RP4

Page: 191 / 192
Rev.: 01

TEST CHANNEL AND METHOD

All tests were performed at a channel center frequency of 5310 MHz utilizing a conducted test method.

CHANNEL MOVE TIME AND CHANNEL CLOSING TRANSMISSION TIME

GENERAL REPORTING NOTES

The reference marker is set at the end of last radar pulse.

The delta marker is set at the end of the last WLAN transmission following the radar pulse. This delta is the channel move time.

The aggregate channel closing transmission time is calculated as follows:

Aggregate Transmission Time =

(Number of analyzer bins showing transmission) * (dwell time per bin)

The observation period over which the aggregate time is calculated

Begins at (Reference Marker + 200 msec) and

Ends no earlier than (Reference Marker + 10 sec).



Report No.: T190315W01-RP4

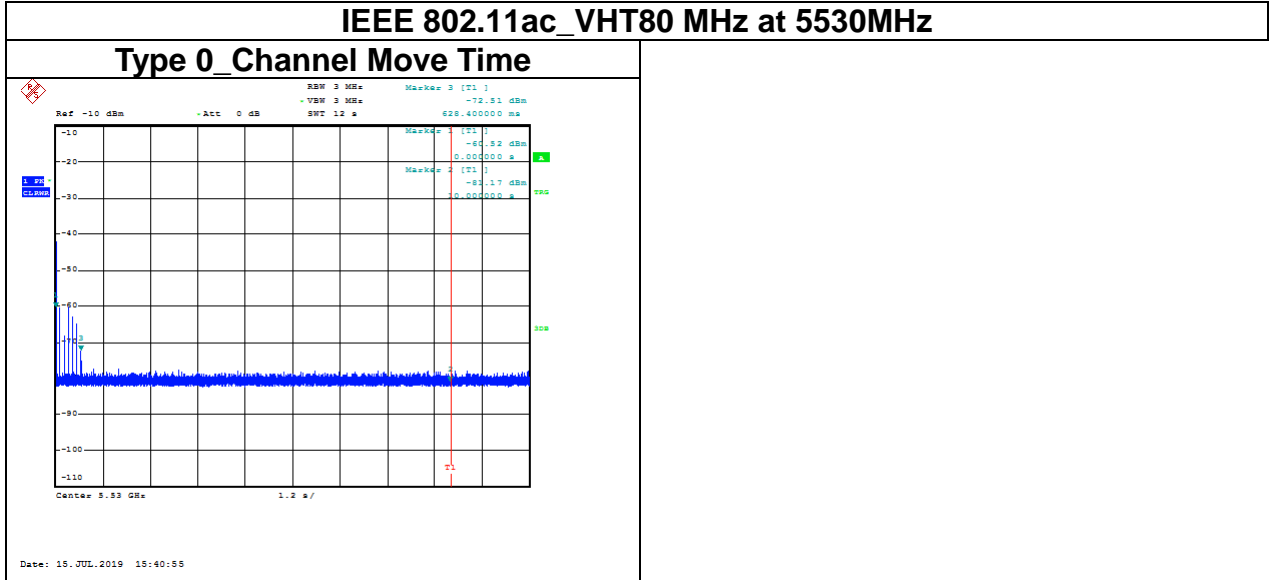

Channel Move Time (s)	Limit (s)
0.6284	10

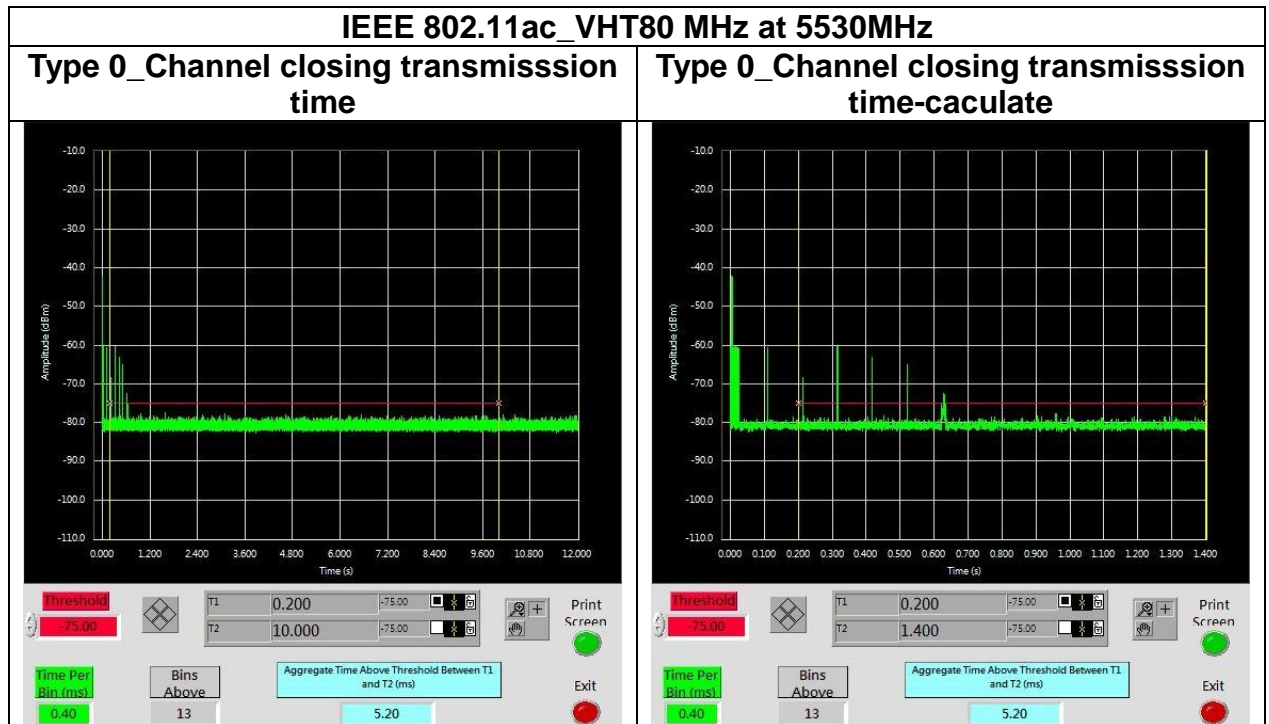

Aggregate Transmission Time (ms)	Limit (ms)	Margin (ms)
5.20	60	-54.8

--End Report--