



A D T

FCC TEST REPORT

REPORT NO.: RF990203H05

MODEL NO.: BT-240-V2

RECEIVED: Feb. 03, 2010

TESTED: Feb. 06 to 10, 2010

ISSUED: Feb. 11, 2010

APPLICANT: CC&C Technologies, Inc.

ADDRESS: 8F, 150, Jian Yi Road, Chung Ho City, Taipei County,
Taiwan 235, R.O.C.

ISSUED BY: Bureau Veritas Consumer Products Services (H.K.)
Ltd., Taoyuan Branch Hsin Chu Laboratory

TEST LOCATION (1) : No. 81-1, Lu Liao Keng, 9th Ling, Wu Lung Tsuen,
Chiung Lin Hsiang, Hsin Chu Hsien 307, Taiwan

TEST LOCATION (2) : No.49, Ln. 206, Wende Rd., Shangshan Tsuen,
Chiung Lin Hsiang, Hsin Chu Hsien, Taiwan (R.O.C.)

This test report consists of 77 pages in total. It may be duplicated completely for legal use with the approval of the applicant. It should not be reproduced except in full, without the written approval of our laboratory. The client should not use it to claim product endorsement by any government agencies. The test results in the report only apply to the tested sample.



TABLE OF CONTENTS

1.	CERTIFICATION	5
2.	SUMMARY OF TEST RESULTS	6
2.1	MEASUREMENT UNCERTAINTY	7
3.	GENERAL INFORMATION.....	8
3.1	GENERAL DESCRIPTION OF EUT	8
3.2	DESCRIPTION OF TEST MODES	9
3.2.1	TEST MODE APPLICABILITY AND TESTED CHANNEL DETAIL	10
3.3	GENERAL DESCRIPTION OF APPLIED STANDARDS	12
3.4	DESCRIPTION OF SUPPORT UNITS.....	13
3.5	CONFIGURATION OF SYSTEM UNDER TEST	14
4.	TEST TYPES AND RESULTS	16
4.1	CONDUCTED EMISSION MEASUREMENT	16
4.1.1	LIMITS OF CONDUCTED EMISSION MEASUREMENT	16
4.1.2	TEST INSTRUMENTS.....	16
4.1.3	TEST PROCEDURES	17
4.1.4	DEVIATION FROM TEST STANDARD	17
4.1.5	TEST SETUP	17
4.1.6	EUT OPERATING CONDITIONS	18
4.1.7	TEST RESULTS(MODE 1)	19
4.1.8	TEST RESULTS(MODE 2)	21
4.2	NUMBER OF HOPPING FREQUENCY USED	23
4.2.1	LIMIT OF HOPPING FREQUENCY USED	23
4.2.2	TEST INSTRUMENTS.....	23
4.2.3	TEST PROCEDURES	23
4.2.4	DEVIATION FROM TEST STANDARD	23
4.2.5	TEST SETUP	24
4.2.6	TEST RESULTS	24
4.3	DWELL TIME ON EACH CHANNEL	28
4.3.1	LIMIT OF DWELL TIME USED	28
4.3.2	TEST INSTRUMENTS.....	28
4.3.3	TEST PROCEDURES	28
4.3.4	DEVIATION FROM TEST STANDARD	28
4.3.5	TEST SETUP	29
4.3.6	TEST RESULTS	30
4.4	CHANNEL BANDWIDTH	40
4.4.1	LIMITS OF CHANNEL BANDWIDTH.....	40



4.4.2	TEST INSTRUMENTS.....	40
4.4.3	TEST PROCEDURE.....	40
4.4.4	DEVIATION FROM TEST STANDARD	40
4.4.5	TEST SETUP	41
4.4.6	EUT OPERATING CONDITION.....	41
4.4.7	TEST RESULTS	42
4.5	HOPPING CHANNEL SEPARATION.....	45
4.5.1	LIMIT OF HOPPING CHANNEL SEPARATION.....	45
4.5.2	TEST INSTRUMENTS.....	45
4.5.3	TEST PROCEDURES	45
4.5.4	DEVIATION FROM TEST STANDARD	46
4.5.5	TEST SETUP	46
4.5.6	TEST RESULTS.....	47
4.6	MAXIMUM PEAK OUTPUT POWER.....	53
4.6.1	LIMITS OF MAXIMUM PEAK OUTPUT POWER MEASUREMENT	53
4.6.2	INSTRUMENTS.....	53
4.6.3	TEST PROCEDURES	53
4.6.4	DEVIATION FROM TEST STANDARD	53
4.6.5	TEST SETUP	54
4.6.6	EUT OPERATING CONDITION.....	54
4.6.7	TEST RESULTS	55
4.7	RADIATED EMISSION MEASUREMENT.....	58
4.7.1	LIMITS OF RADIATED EMISSION MEASUREMENT.....	58
4.7.2	TEST INSTRUMENTS.....	59
4.7.3	TEST PROCEDURES	60
4.7.4	DEVIATION FROM TEST STANDARD	60
4.7.5	TEST SETUP	61
4.7.6	EUT OPERATING CONDITIONS	61
	Below 1GHz Test Data	62
4.7.7	TEST RESULTS	62
	Above 1GHz Test Data	63
4.7.8	TEST RESULTS	63
4.8	CONDUCTED OUT-BAND EMISSION MEASUREMENT.....	69
4.8.1	LIMITS OF CONDUCTED OUT-BAND EMISSION MEASUREMENT	69
4.8.2	TEST INSTRUMENTS.....	69
4.8.3	TEST PROCEDURE.....	69
4.8.4	DEVIATION FROM TEST STANDARD	69
4.8.5	EUT OPERATING CONDITION.....	69
4.8.6	TEST RESULTS	70



A D T

5. INFORMATION ON THE TESTING LABORATORIES 76
**6. APPENDIX - A MODIFICATIONS RECORDERS FOR ENGINEERING CHANGES
TO THE EUT BY THE LAB 77**



A D T

1. CERTIFICATION

PRODUCT : RS-232 Serial Adapter
BRAND : CC&C
MODEL NO.: BT-240-V2
APPLICANT : CC&C Technologies, Inc.
TESTED : Feb. 06 to 10, 2010
TEST SAMPLE : ENGINEERING SAMPLE
STANDARDS : FCC Part 15, Subpart C (Section 15.247),
ANSI C63.4-2003

The above equipment (Model: BT-240-V2) has been tested by **Bureau Veritas Consumer Products Services (H.K.) Ltd., Taoyuan Branch**, and found compliance with the requirement of the above standards. The test record, data evaluation & Equipment Under Test (EUT) configurations represented herein are true and accurate accounts of the measurements of the sample's EMC characteristics under the conditions specified in this report.

PREPARED BY :  , **DATE:** Feb. 11, 2010
(Claire Kaun, Specialist)

TECHNICAL ACCEPTANCE :  , **DATE:** Feb. 11, 2010
(Hank Chung, Deputy Manager)

APPROVED BY :  , **DATE:** Feb. 11, 2010
(May Chen, Deputy Manager)



2. SUMMARY OF TEST RESULTS

The EUT has been tested according to the following specifications:

APPLIED STANDARD: 47 CFR Part 15, Subpart C			
Standard Section	Test Type and Limit	Result	REMARK
15.207	AC Power Conducted Emission	PASS	Meet the requirement of limit. Minimum passing margin is -22.97dB at 7.628MHz.
15.247(a)(1)(I)-(ii)	Number of Hopping Frequency Used Spec.: At least 15 channels	PASS	Meet the requirement of limit
15.247(a)(1)(ii)	Dwell Time on Each Channel Spec.: Max. 0.4 second within 31.6 second	PASS	Meet the requirement of limit
15.247(a)(1)(I)-(ii)	Hopping Channel Separation Spec. : Min. 25 kHz or two-thirds of 20 dB bandwidth, which ever is greater	PASS	Meet the requirement of limit
15.247(a)(2)	Spectrum Bandwidth of a Frequency Hopping Sequence Spread Spectrum System	PASS	Meet the requirement of limit
15.247(b)	Maximum Peak Output Power Spec.: max. 125mW	PASS	Meet the requirement of limit
15.247(c)	Transmitter Radiated Emissions Spec.: Table 15.209	PASS	Meet the requirement of limit. Minimum passing margin is -3.7dB at 51.67MHz.
15.247(c)	Conducted Out-Band Emissions Measurement	PASS	Meet the requirement of limit
15.203	Antenna Requirement	PASS	No antenna connector is used.



A D T

2.1 MEASUREMENT UNCERTAINTY

Where relevant, the following measurement uncertainty levels have been estimated for tests performed on the EUT as specified in CISPR 16-4-2:

This uncertainty represents an expanded uncertainty expressed at approximately the 95% confidence level using a coverage factor of $k=2$.

Measurement	Value
Conducted emissions	2.45 dB
Radiated emissions (30MHz-1GHz)	3.3 dB
Radiated emissions (1GHz -18GHz)	2.19 dB
Radiated emissions (18GHz -40GHz)	2.56 dB



3. GENERAL INFORMATION

3.1 GENERAL DESCRIPTION OF EUT

PRODUCT	RS-232 Serial Adapter
MODEL NO.	BT-240-V2
FCC ID	PANBT240-V2
POWER SUPPLY	7.5VDC
MODULATION TYPE	GFSK, $\pi/4$ -DQPSK, 8DPSK
MODULATION TECHNOLOGY	FHSS
TRANSFER RATE	3/2/1 Mbits/s
FREQUENCY RANGE	2402MHz ~ 2480MHz
NUMBER OF CHANNEL	79
MAXIMUM OUTPUT POWER	GFSK: 7.9 mW $\pi/4$ -DQPSK: 9.1mW 8DPSK: 9.5mW
ANTENNA TYPE	Printed antenna (Gain: 1.2 dBi)
ANTENNA CONNECTOR	NA
DATA CABLE	RS232 cable(Unshielded, 0.32m)
I/O PORT	RS232 port x 1 (There are two connectors could be chosen: DCE & DTE)
ASSOCIATED DEVICES	RS232 cable x 1 Adapter x 1

NOTE:

- The EUT was pre-tested in chamber under the following modes

Pre-test Mode	Description
Mode A	DCE connector
Mode B	DTE connector

From the above modes, the worst case was found in **Mode B**. Therefore only the test data of the modes were recorded in this report.

- The EUT must be supplied with a power adapter as following information:

Brand:	HON-KWANG
Model No.:	D7300
Input power :	AC 120V 60Hz 9W
Output power :	DC 7.5V, 300mA DC output cable (Unshielded, 1.8m)



3. The EUT was pre-tested in chamber under the following modes:

Pre-test Mode	Description
Mode A	Level-set (Put on tabletop)
Mode B	Tower-set (Wall-mounted)

From the above modes, the worst case was found in **Mode A**. Therefore only the test data of the modes were recorded in this report.

4. The above EUT information was declared by manufacturer and for more detailed features description, please refer to the manufacturer's specifications or user's manual.

3.2 DESCRIPTION OF TEST MODES

Operated in 2400 ~ 2483.5MHz band:

Seventy-nine channels are provided to this EUT.

CHANNEL	FREQ. (MHZ)	CHANNEL	FREQ. (MHZ)	CHANNEL	FREQ. (MHZ)	CHANNEL	FREQ. (MHZ)
0	2402	20	2422	40	2442	60	2462
1	2403	21	2423	41	2443	61	2463
2	2404	22	2424	42	2444	62	2464
3	2405	23	2425	43	2445	63	2465
4	2406	24	2426	44	2446	64	2466
5	2407	25	2427	45	2447	65	2467
6	2408	26	2428	46	2448	66	2468
7	2409	27	2429	47	2449	67	2469
8	2410	28	2430	48	2450	68	2470
9	2411	29	2431	49	2451	69	2471
10	2412	30	2432	50	2452	70	2472
11	2413	31	2433	51	2453	71	2473
12	2414	32	2434	52	2454	72	2474
13	2415	33	2435	53	2455	73	2475
14	2416	34	2436	54	2456	74	2476
15	2417	35	2437	55	2457	75	2477
16	2418	36	2438	56	2458	76	2478
17	2419	37	2439	57	2459	77	2479
18	2420	38	2440	58	2460	78	2480
19	2421	39	2441	59	2461		



3.2.1 TEST MODE APPLICABILITY AND TESTED CHANNEL DETAIL

EUT CONFIGURE MODE	APPLICABLE TO				DESCRIPTION
	PLC	RE < 1G	RE ≥ 1G	APCM	
MODE 1	√	-	-	-	Bluetooth transmission + Power Adapter + DCE connector
MODE 2	√	√	√	√	Bluetooth transmission + Power Adapter + DTE connector

Where **PLC**: Power Line Conducted Emission **RE < 1G**: Radiated Emission below 1GHz
RE ≥ 1G: Radiated Emission above 1GHz **APCM**: Antenna Port Conducted Measurement

POWER LINE CONDUCTED EMISSION TEST:

- Pre-Scan has been conducted to determine the worst-case mode from all possible combinations between available modulations, data rates and antenna ports (if EUT with antenna diversity architecture).
- Following channel(s) was (were) selected for the final test as listed below.

EUT CONFIGURE MODE	AVAILABLE CHANNEL	TESTED CHANNEL	MODULATION TECHNOLOGY	MODULATION TYPE
MODE 1	0 to 78	0	FHSS	GFSK
MODE 2	0 to 78	0	FHSS	GFSK

RADIATED EMISSION TEST (BELOW 1 GHZ):

- Pre-Scan has been conducted to determine the worst-case mode from all possible combinations between available modulations, data rates and antenna ports (if EUT with antenna diversity architecture).
- Following channel(s) was (were) selected for the final test as listed below.

EUT CONFIGURE MODE	AVAILABLE CHANNEL	TESTED CHANNEL	MODULATION TECHNOLOGY	MODULATION TYPE
MODE 2	0 to 78	0	FHSS	GFSK



RADIATED EMISSION TEST (ABOVE 1 GHZ):

- Pre-Scan has been conducted to determine the worst-case mode from all possible combinations between available modulations, data rates and antenna ports (if EUT with antenna diversity architecture).
- Following channel(s) was (were) selected for the final test as listed below.

EUT CONFIGURE MODE	AVAILABLE CHANNEL	TESTED CHANNEL	MODULATION TECHNOLOGY	MODULATION TYPE
MODE 2	0 to 78	0, 39, 78	FHSS	GFSK
MODE 2	0 to 78	0, 39, 78	FHSS	8DPSK

BANDEDGE MEASUREMENT:

- Pre-Scan has been conducted to determine the worst-case mode from all possible combinations between available modulations, data rates and antenna ports (if EUT with antenna diversity architecture).
- Following channel(s) was (were) selected for the final test as listed below.

EUT CONFIGURE MODE	AVAILABLE CHANNEL	TESTED CHANNEL	MODULATION TECHNOLOGY	MODULATION TYPE
MODE 2	0 to 78	0, 78	FHSS	GFSK
MODE 2	0 to 78	0, 78	FHSS	$\pi/4$ -DQPSK
MODE 2	0 to 78	0, 78	FHSS	8DPSK

ANTENNA PORT CONDUCTED MEASUREMENT:

- This item includes all test value of each mode, but only includes spectrum plot of worst value of each mode.
- Pre-Scan has been conducted to determine the worst-case mode from all possible combinations between available modulations, data rates and antenna ports (if EUT with antenna diversity architecture).
- Following channel(s) was (were) selected for the final test as listed below.

EUT CONFIGURE MODE	AVAILABLE CHANNEL	TESTED CHANNEL	MODULATION TECHNOLOGY	MODULATION TYPE
MODE 2	0 to 78	0, 78	FHSS	GFSK
MODE 2	0 to 78	0, 78	FHSS	$\pi/4$ -DQPSK
MODE 2	0 to 78	0, 78	FHSS	8DPSK

TEST CONDITION:

APPLICABLE TO	ENVIRONMENTAL CONDITIONS	INPUT POWER (SYSTEM)	TESTED BY
RE ³ 1G	19deg. C, 71%RH, 1023 hPa	120Vac, 60Hz	Rex Huang
RE<1G	20deg. C, 65%RH, 1023 hPa	120Vac, 60Hz	Rex Huang
PLC	24deg. C, 61%RH, 1023 hPa	120Vac, 60Hz	Andy Ho
APCM	25deg. C, 60%RH, 1023 hPa	120Vac, 60Hz	Rex Huang



A D T

3.3 GENERAL DESCRIPTION OF APPLIED STANDARDS

The EUT is an RF product. According to the specifications of the manufacturer, it must comply with the requirements of the following standards:

FCC Part 15, Subpart C. (15.247)

ANSI C63.4-2003

All test items have been performed and recorded as per the above standards.

NOTE: The EUT is also considered as a kind of computer peripheral, because the connection to computer is necessary for typical use. It has been verified to comply with the requirements of FCC Part 15, Subpart B, Class B (DoC). The test report has been issued separately.



3.4 DESCRIPTION OF SUPPORT UNITS

The EUT has been tested as an independent unit together with other necessary accessories or support units. The following support units or accessories were used to form a representative test configuration during the tests.

NO.	PRODUCT	BRAND	MODEL NO.	SERIAL NO.	FCC ID
1	NOTEBOOK COMPUTER	DELL	PP17L	CN-ONF743-48643-7AV-0124	FCC DoC
2	NOTEBOOK COMPUTER	DELL	PP32LA	GSLB32S	FCC DoC
3	iPod	Apple	A1137	6U6078FMUPR	FCC DoC

NO.	SIGNAL CABLE DESCRIPTION OF THE ABOVE SUPPORT UNITS
1	0.32m, RS232 cable
2	NA
3	1.2 m, shielded cable, terminated with USB connector, w/o core.

NOTE: All power cords of the above support units are non shielded (1.8m).

3.5 CONFIGURATION OF SYSTEM UNDER TEST

Conducted emission test mode:

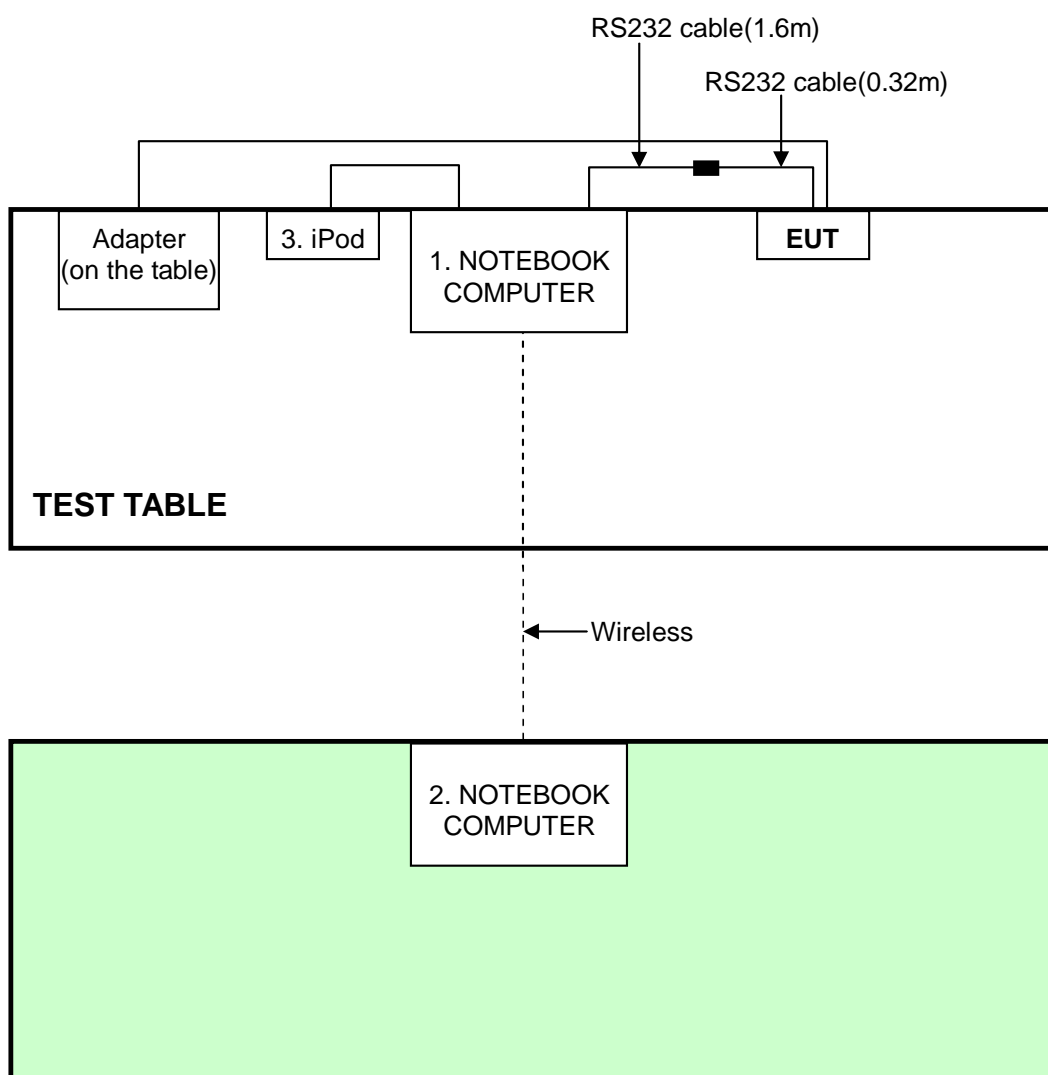

Other test mode:

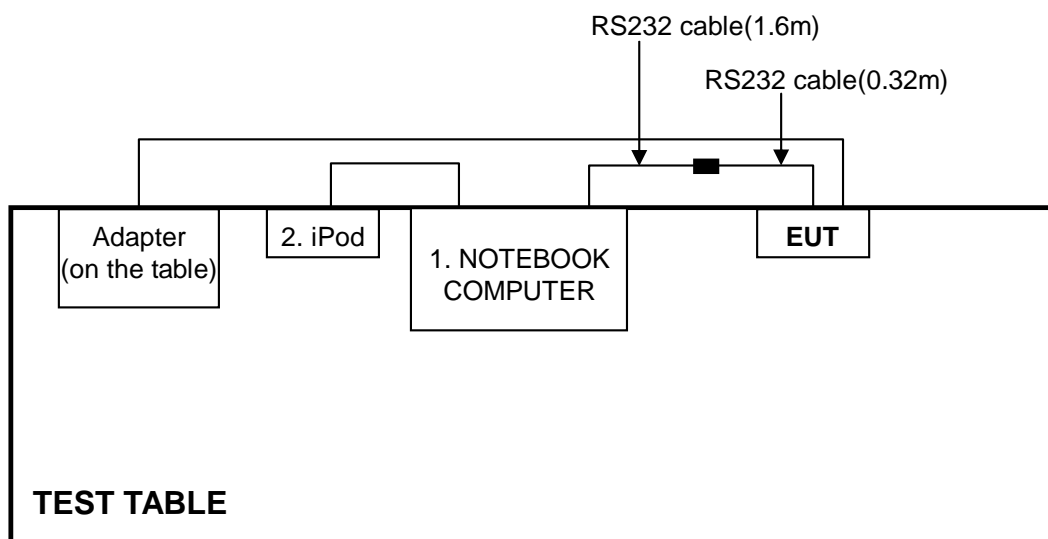



4. TEST TYPES AND RESULTS

4.1 CONDUCTED EMISSION MEASUREMENT

4.1.1 LIMITS OF CONDUCTED EMISSION MEASUREMENT

FREQUENCY OF EMISSION (MHz)	CONDUCTED LIMIT (dB μ V)	
	Quasi-peak	Average
0.15-0.5	66 to 56	56 to 46
0.5-5	56	46
5-30	60	50

- NOTE:**
1. The lower limit shall apply at the transition frequencies.
 2. The limit decreases in line with the logarithm of the frequency in the range of 0.15 to 0.50 MHz.
 3. All emanations from a class A/B digital device or system, including any network of conductors and apparatus connected thereto, shall not exceed the level of field strengths specified above.

4.1.2 TEST INSTRUMENTS

DESCRIPTION & MANUFACTURER	MODEL NO.	SERIAL NO.	CALIBRATED DATE	CALIBRATED UNTIL
ROHDE & SCHWARZ Test Receiver	ESCS 30	100287	Mar. 05, 2009	Mar. 04, 2010
Line-Impedance Stabilization Network (for EUT)	NSLK 8127	8127-523	Sep 23,2009	Sep 22, 2010
Line-Impedance Stabilization Network (for Peripheral)	KNW-407	8-1395-12	May 04, 2009	May 03, 2010
RF Cable (JYEBAO)	5DFB	COACAB-001	Dec 14, 2009	Dec 13, 2010
50 ohms Terminator	50	3	Oct. 28, 2009	Oct. 27, 2010
Software	BV ADT_Cond_V7.3.7	NA	NA	NA

Note:

1. The calibration interval of the above test instruments is 12 months and the calibrations are traceable to NML/ROC and NIST/USA.
2. The test was performed in Shielded Room No. A.
- 3 The VCCI Con A Registration No. is C-817.

4.1.3 TEST PROCEDURES

- a. The EUT was placed 0.4 meters from the conducting wall of the shielded room with EUT being connected to the power mains through a line impedance stabilization network (LISN). Other support units were connected to the power mains through another LISN. The two LISNs provide 50 ohm/ 50uH of coupling impedance for the measuring instrument.
- b. Both lines of the power mains connected to the EUT were checked for maximum conducted interference.
- c. The frequency range from 150kHz to 30MHz was searched. Emission levels under (Limit - 20dB) was not recorded.

4.1.4 DEVIATION FROM TEST STANDARD

No deviation

4.1.5 TEST SETUP

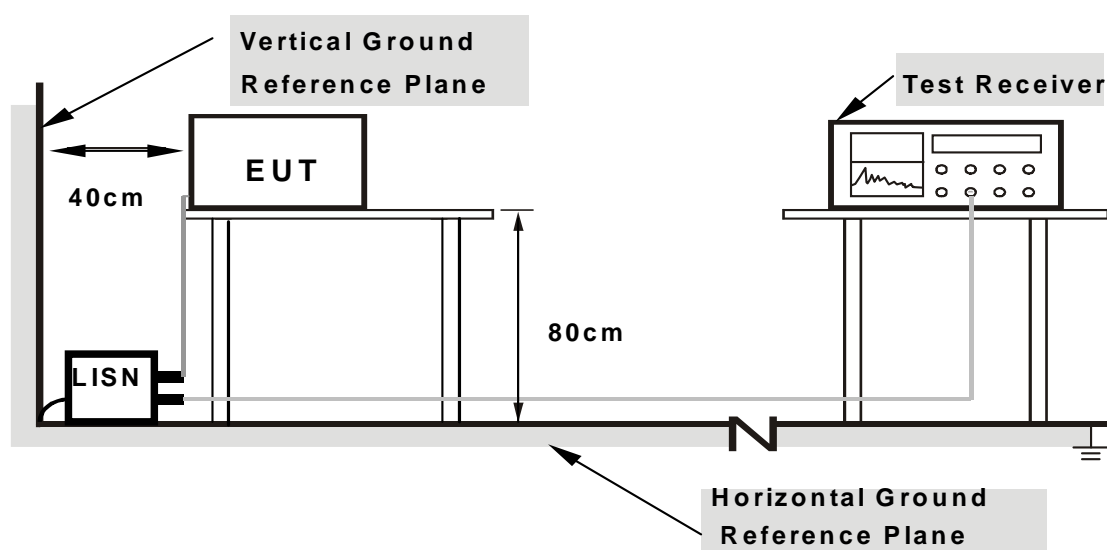

Note: 1. Support units were connected to second LISN.

2. Both of LISNs (AMN) are 80 cm from EUT and at least 80 from other units and other metal planes

For the actual test configuration, please refer to the related item – Photographs of the Test Configuration.



A D T

4.1.6 EUT OPERATING CONDITIONS

1. Connect the EUT with the support unit 1 (Notebook Computer) which placed on a testing table.
2. The communication partner run test program “CSR Blue Test” to enable EUT under transmission/receiving condition continuously.



A D T

4.1.7 TEST RESULTS(MODE 1)

PHASE	Line (L)	6dB BANDWIDTH	9 kHz
TEST MODE	Normal Mode		

No	Freq. [MHz]	Corr. Factor (dB)	Reading Value [dB (uV)]		Emission Level [dB (uV)]		Limit [dB (uV)]		Margin (dB)	
			Q.P.	AV.	Q.P.	AV.	Q.P.	AV.	Q.P.	AV.
	1	0.150	0.04	29.43	-	29.47	-	66.00	56.00	-36.53
2	0.463	0.06	25.25	-	25.31	-	56.65	46.65	-31.33	-
3	0.787	0.08	19.15	-	19.23	-	56.00	46.00	-36.77	-
4	7.628	0.30	36.73	-	37.03	-	60.00	50.00	-22.97	-
5	15.363	0.47	32.73	-	33.20	-	60.00	50.00	-26.80	-
6	23.648	0.68	32.78	-	33.46	-	60.00	50.00	-26.54	-

- REMARKS:**
1. Q.P. and AV. are abbreviations of quasi-peak and average individually.
 2. "-": The Quasi-peak reading value also meets average limit and measurement with the average detector is unnecessary.
 3. The emission levels of other frequencies were very low against the limit.
 4. Margin value = Emission level - Limit value
 5. Correction factor = Insertion loss + Cable loss
 6. Emission Level = Correction Factor + Reading Value.

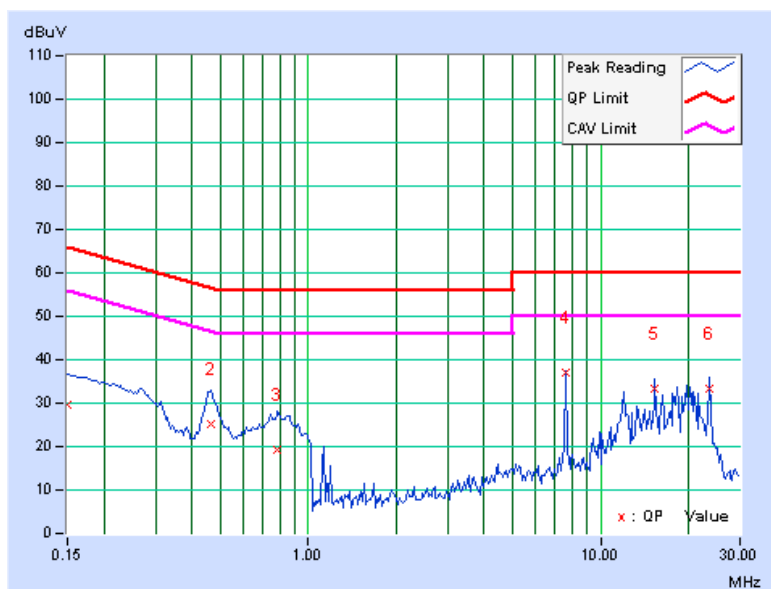



A D T

PHASE	Neutral (N)	6dB BANDWIDTH	9 kHz
TEST MODE	Normal Mode		

No	Freq. [MHz]	Corr. Factor (dB)	Reading Value [dB (uV)]		Emission Level [dB (uV)]		Limit [dB (uV)]		Margin (dB)	
			Q.P.	AV.	Q.P.	AV.	Q.P.	AV.	Q.P.	AV.
	1	0.267	0.06	30.57	-	30.63	-	61.20	51.20	-30.58
2	0.478	0.07	31.37	-	31.44	-	56.37	46.37	-24.93	-
3	7.628	0.31	35.42	-	35.73	-	60.00	50.00	-24.27	-
4	15.363	0.49	32.57	-	33.06	-	60.00	50.00	-26.94	-
5	19.708	0.56	31.42	-	31.98	-	60.00	50.00	-28.02	-
6	23.648	0.69	28.81	-	29.50	-	60.00	50.00	-30.50	-

- REMARKS:**
1. Q.P. and AV. are abbreviations of quasi-peak and average individually.
 2. "-": The Quasi-peak reading value also meets average limit and measurement with the average detector is unnecessary.
 3. The emission levels of other frequencies were very low against the limit.
 4. Margin value = Emission level - Limit value
 5. Correction factor = Insertion loss + Cable loss
 6. Emission Level = Correction Factor + Reading Value.

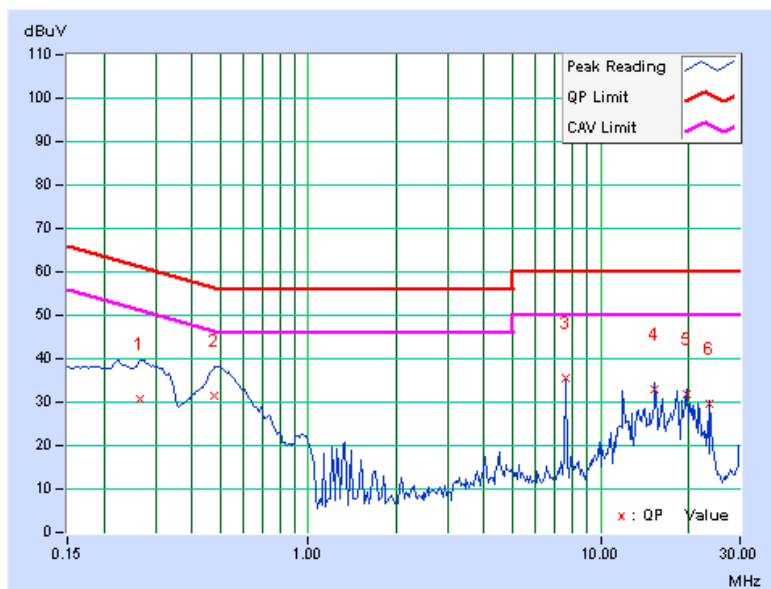



A D T

4.1.8 TEST RESULTS(MODE 2)

PHASE	Line (L)	6dB BANDWIDTH	9 kHz
TEST MODE	Normal Mode		

No	Freq. [MHz]	Corr. Factor (dB)	Reading Value [dB (uV)]		Emission Level [dB (uV)]		Limit [dB (uV)]		Margin (dB)	
			Q.P.	AV.	Q.P.	AV.	Q.P.	AV.	Q.P.	AV.
	1	0.158	0.04	22.26	-	22.30	-	65.58	55.58	-43.28
2	0.259	0.05	20.96	-	21.01	-	61.45	51.45	-40.45	-
3	0.545	0.07	19.83	-	19.90	-	56.00	46.00	-36.10	-
4	0.619	0.07	15.22	-	15.29	-	56.00	46.00	-40.71	-
5	10.047	0.36	24.14	-	24.50	-	60.00	50.00	-35.50	-
6	18.010	0.51	25.64	-	26.15	-	60.00	50.00	-33.85	-

- REMARKS:**
1. Q.P. and AV. are abbreviations of quasi-peak and average individually.
 2. "-": The Quasi-peak reading value also meets average limit and measurement with the average detector is unnecessary.
 3. The emission levels of other frequencies were very low against the limit.
 4. Margin value = Emission level - Limit value
 5. Correction factor = Insertion loss + Cable loss
 6. Emission Level = Correction Factor + Reading Value.

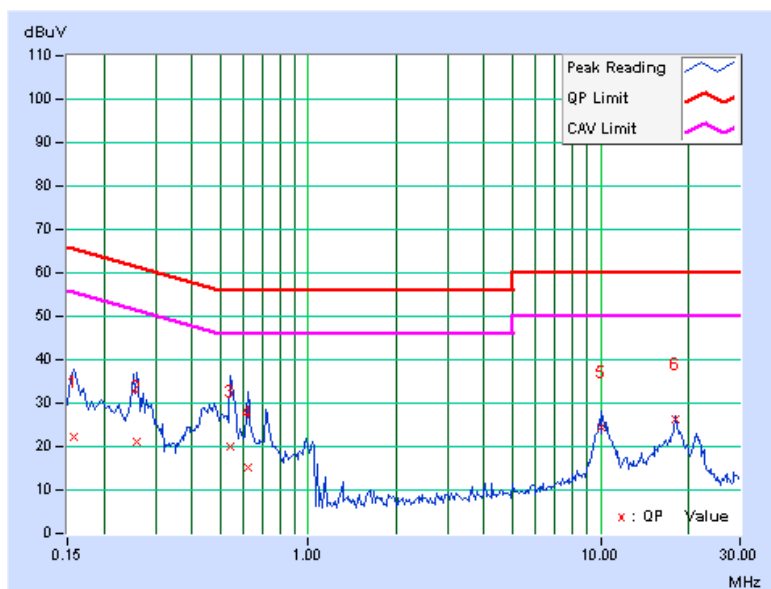



A D T

PHASE	Neutral (N)	6dB BANDWIDTH	9 kHz
TEST MODE	Normal Mode		

No	Freq. [MHz]	Corr. Factor (dB)	Reading Value [dB (uV)]		Emission Level [dB (uV)]		Limit [dB (uV)]		Margin (dB)	
			Q.P.	AV.	Q.P.	AV.	Q.P.	AV.	Q.P.	AV.
	1	0.150	0.05	22.44	-	22.49	-	66.00	56.00	-43.51
2	0.224	0.05	22.26	-	22.31	-	62.66	52.66	-40.35	-
3	0.525	0.08	19.43	-	19.51	-	56.00	46.00	-36.49	-
4	0.591	0.08	15.86	-	15.94	-	56.00	46.00	-40.06	-
5	10.367	0.38	23.26	-	23.64	-	60.00	50.00	-36.36	-
6	18.012	0.53	24.48	-	25.01	-	60.00	50.00	-34.99	-

- REMARKS:**
1. Q.P. and AV. are abbreviations of quasi-peak and average individually.
 2. "-": The Quasi-peak reading value also meets average limit and measurement with the average detector is unnecessary.
 3. The emission levels of other frequencies were very low against the limit.
 4. Margin value = Emission level - Limit value
 5. Correction factor = Insertion loss + Cable loss
 6. Emission Level = Correction Factor + Reading Value.

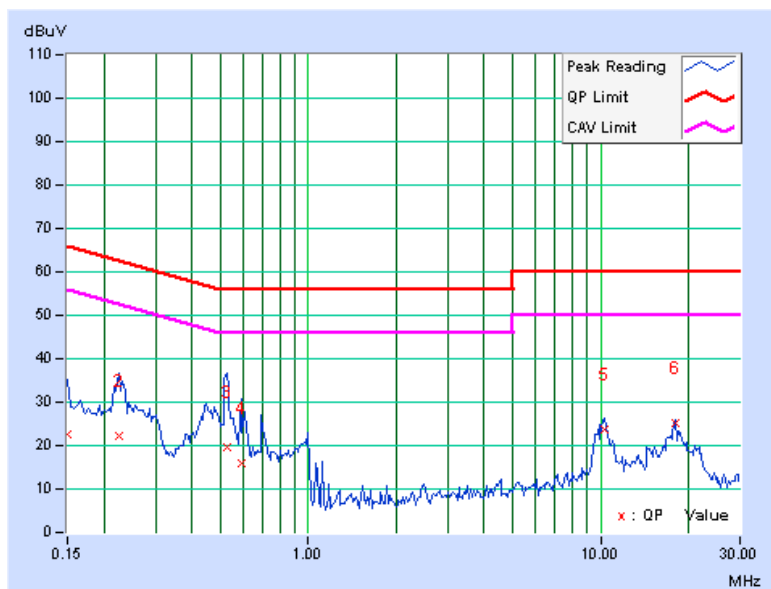



A D T

4.2 NUMBER OF HOPPING FREQUENCY USED

4.2.1 LIMIT OF HOPPING FREQUENCY USED

At least 15 hopping frequencies, and should be equally spaced.

4.2.2 TEST INSTRUMENTS

DESCRIPTION & MANUFACTURER	MODEL NO.	SERIAL NO.	CALIBRATED DATE	CALIBRATED UNTIL
R&S SPECTRUM ANALYZER	FSP40	100037	Aug. 09, 2009	Aug. 08, 2010

NOTE:

1. The calibration interval of the above test instruments is 12 months and the calibrations are traceable to NML/ROC and NIST/USA.

4.2.3 TEST PROCEDURES

1. Check the calibration of the measuring instrument (SA) using either an internal calibrator or a known signal from an external generator.
2. Turn on the EUT and connect its antenna terminal to measurement via a low loss cable. Then set it to any one measured frequency within its operating range and make sure the instrument is operated in its linear range.
3. Set the SA on MaxHold Mode, and then keep the EUT in hopping mode. Record all the signals from each channel until each one has been recorded.
4. Set the SA on View mode and then plot the result on SA screen.
5. Repeat above procedures until all frequencies measured were complete.

4.2.4 DEVIATION FROM TEST STANDARD

No deviation

4.2.5 TEST SETUP

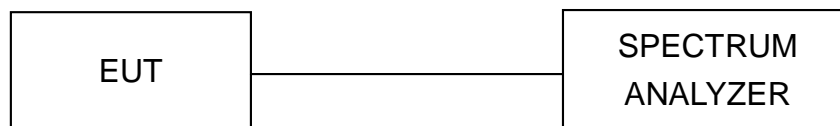

4.2.6 TEST RESULTS

There are 79 hopping frequencies in the hopping mode. Please refer to next pages for the test result. On the plots, it shows that the hopping frequencies are equally spaced.



A D T

For GFSK :

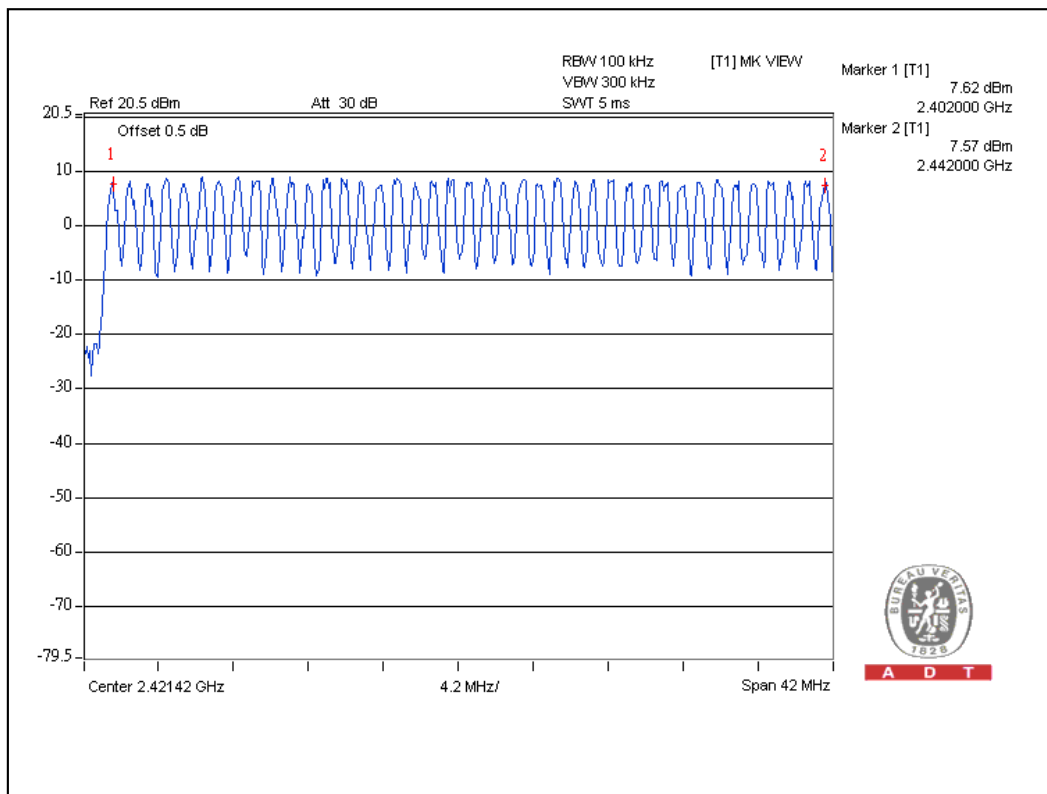

A D T

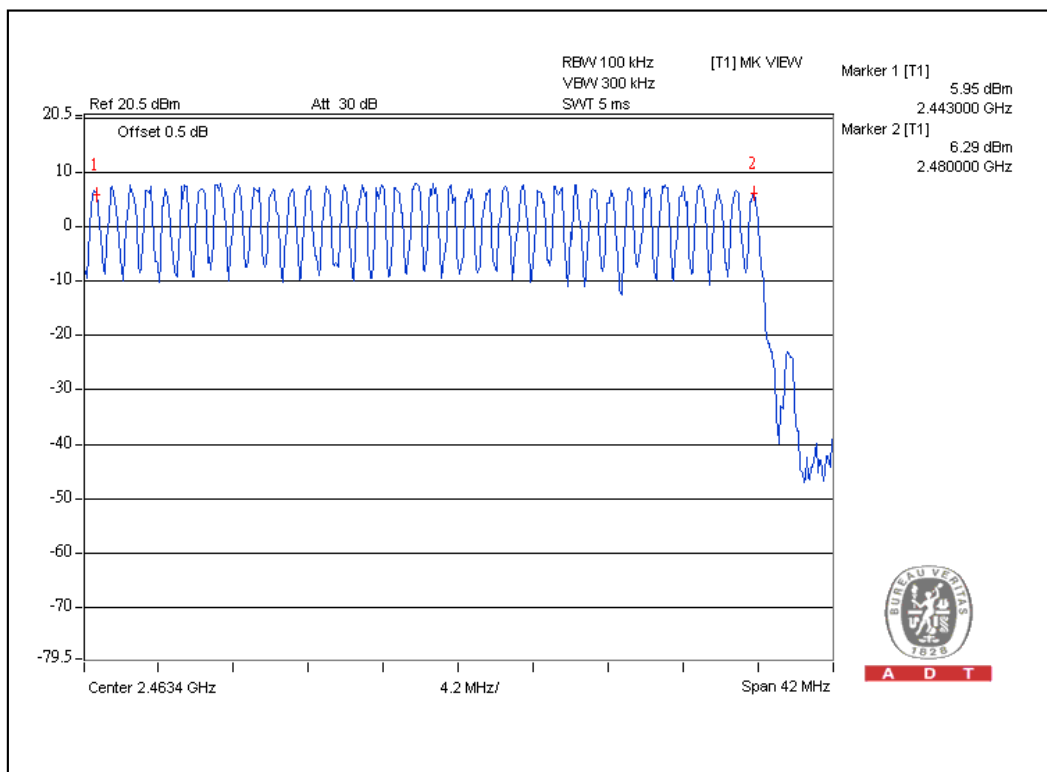

A D T



A D T

For $\pi/4$ -DQPSK :

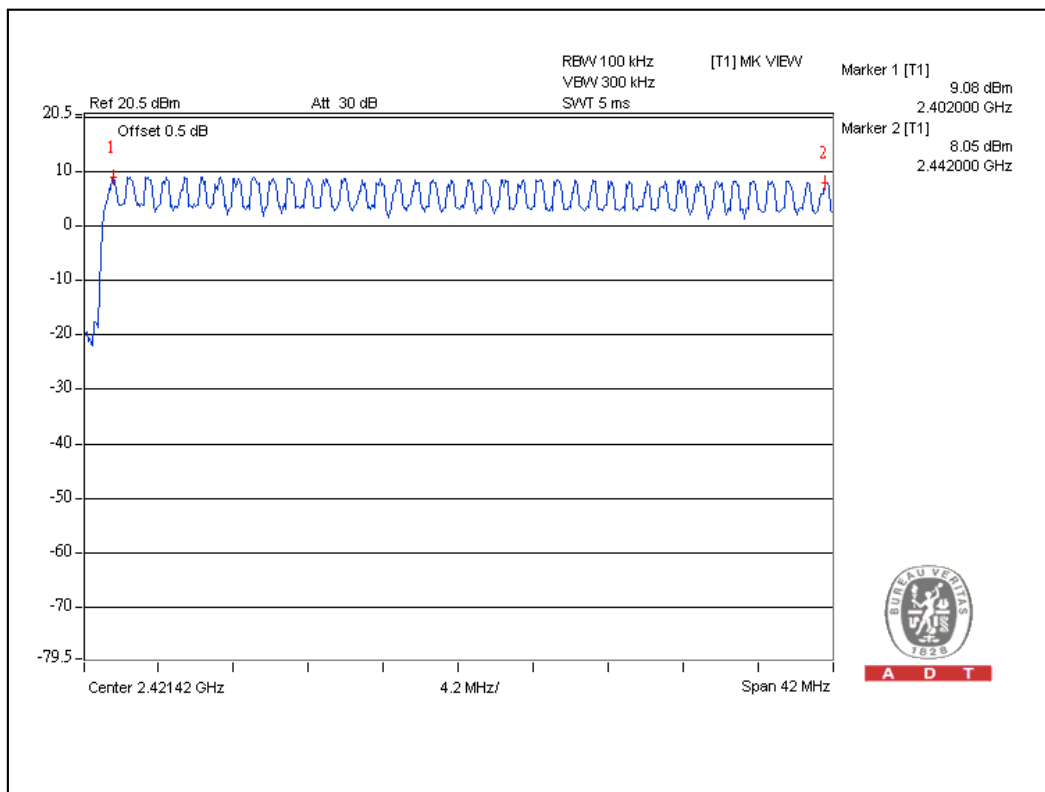

A D T

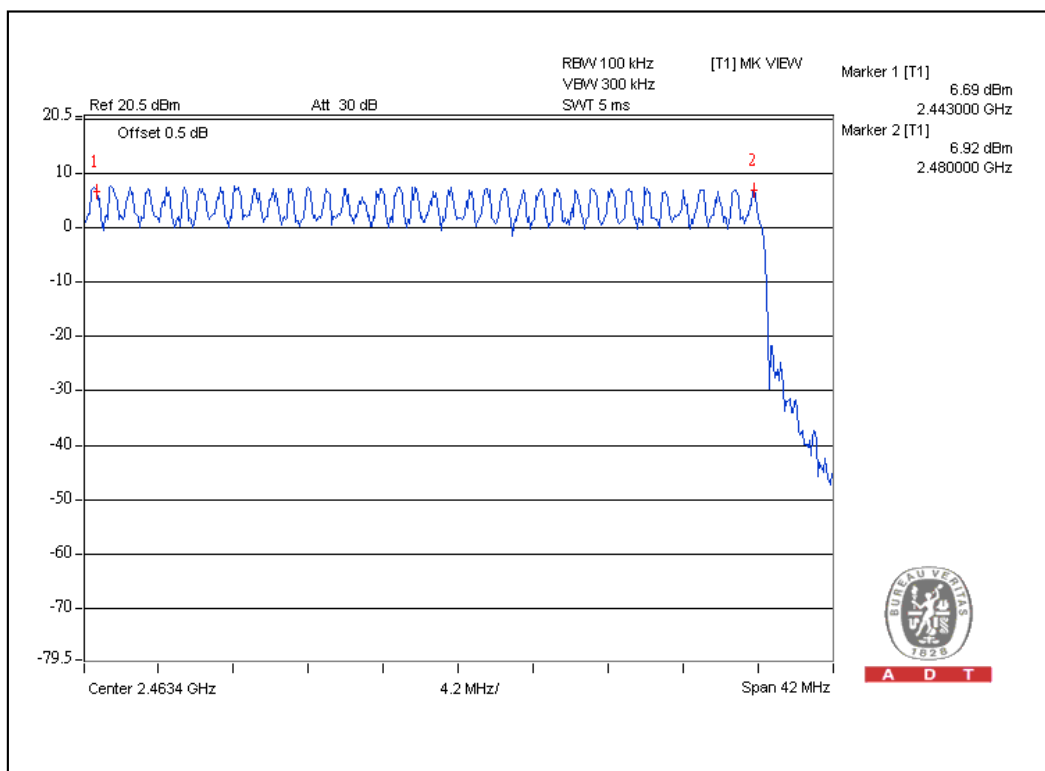

A D T



A D T

For 8DPSK :

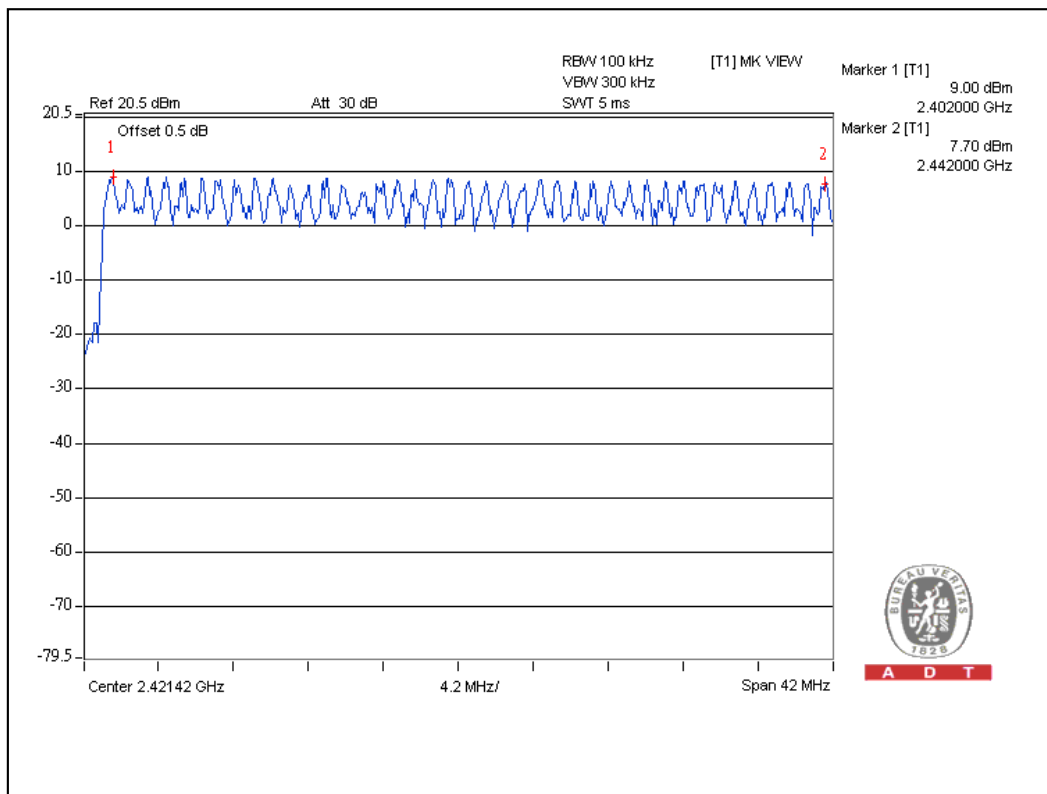

A D T

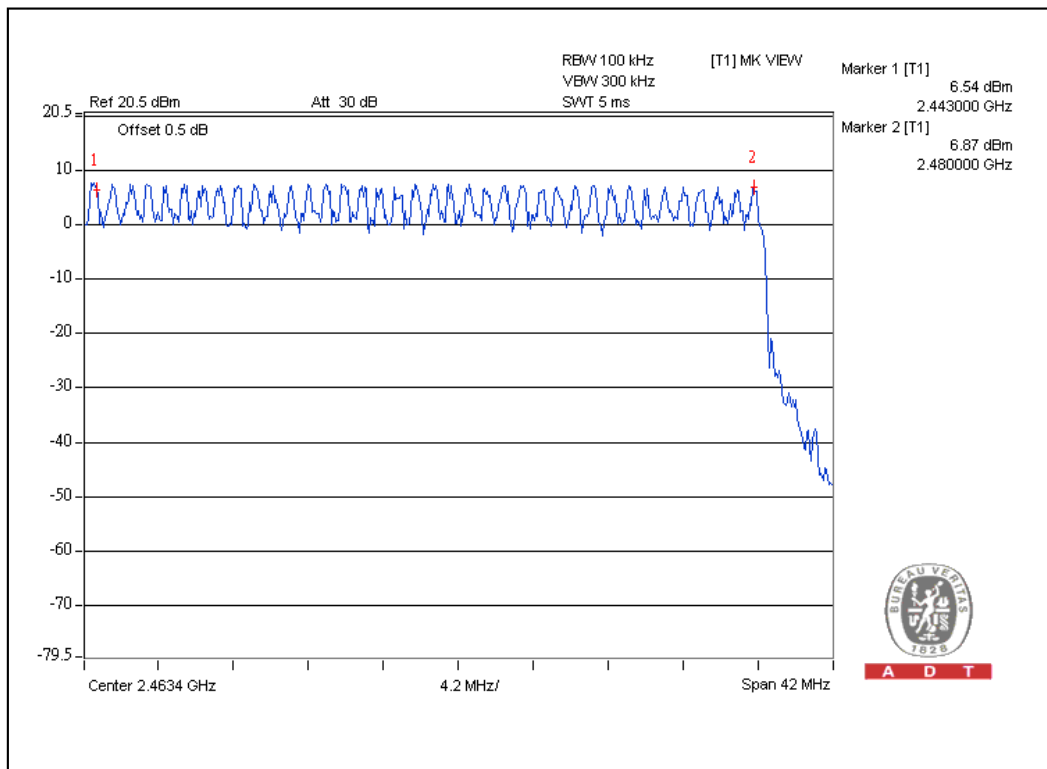

A D T



4.3 DWELL TIME ON EACH CHANNEL

4.3.1 LIMIT OF DWELL TIME USED

For FHSS, the average time of occupancy on any frequency shall not be greater than 0.4 seconds within a 31.6 second period. For hybrid systems, the average time of occupancy on any frequency should not exceed 0.4 seconds within a time period in seconds equal to the number of hopping frequencies employed multiplied by 0.4.

4.3.2 TEST INSTRUMENTS

DESCRIPTION & MANUFACTURER	MODEL NO.	SERIAL NO.	CALIBRATED DATE	CALIBRATED UNTIL
R&S SPECTRUM ANALYZER	FSP40	100037	Aug. 09, 2009	Aug. 08, 2010

NOTE:

- 1.The calibration interval of the above test instruments is 12 months and the calibrations are traceable to NML/ROC and NIST/USA.

4.3.3 TEST PROCEDURES

1. Check the calibration of the measuring instrument (SA) using either an internal calibrator or a known signal from an external generator.
2. Turn on the EUT and connect its antenna terminal to measurement via a low loss cable. Then set it to any one measured frequency within its operating range and make sure the instrument is operated in its linear range.
3. Adjust the center frequency of SA on any frequency be measured and set SA to zero span mode. And then, set RBW and VBW of spectrum analyzer to proper value.
4. Measure the time duration of one transmission on the measured frequency. And then plot the result with time difference of this time duration.
5. Repeat above procedures until all frequencies measured were complete.

4.3.4 DEVIATION FROM TEST STANDARD

No deviation



4.3.5 TEST SETUP

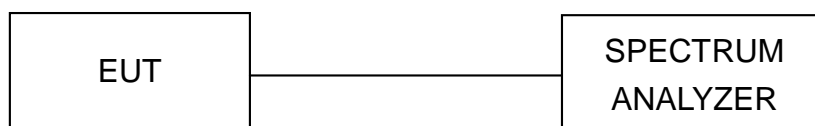



4.3.6 TEST RESULTS

For GFSK :

Mode	Number of transmission in a 31.6 (79Hopping*0.4)	Length of transmission time (msec)	Result (msec)	Limit (msec)
DH1	50 (times / 5 sec) *6.32=316 times	0.444	140.3	400
DH3	25 (times / 5 sec) *6.32=158 times	1.716	271.1	400
DH5	17 (times / 5 sec) *6.32=107.44 times	3	322.3	400

For $\pi/4$ -DQPSK :

Mode	Number of transmission in a 31.6 (79Hopping*0.4)	Length of transmission time (msec)	Result (msec)	Limit (msec)
DH1	51 (times / 5 sec) *6.32=322.32 times	0.468	154.7	400
DH3	25 (times / 5 sec) *6.32=158 times	1.764	279.3	400
DH5	17 (times / 5 sec) *6.32=107.44 times	3.03	278.7	400

For 8DPSK :

Mode	Number of transmission in a 31.6 (79Hopping*0.4)	Length of transmission time (msec)	Result (msec)	Limit (msec)
DH1	50 (times / 5 sec) *6.32=316 times	0.048	151.7	400
DH3	25 (times / 5 sec) *6.32=158 times	1.752	276.8	400
DH5	17 (times / 5 sec) *6.32=107.44 times	3.01	323.4	400

Test plots of the transmitting time slot are shown on next nine pages.

For GFSK :
DH1



A D T

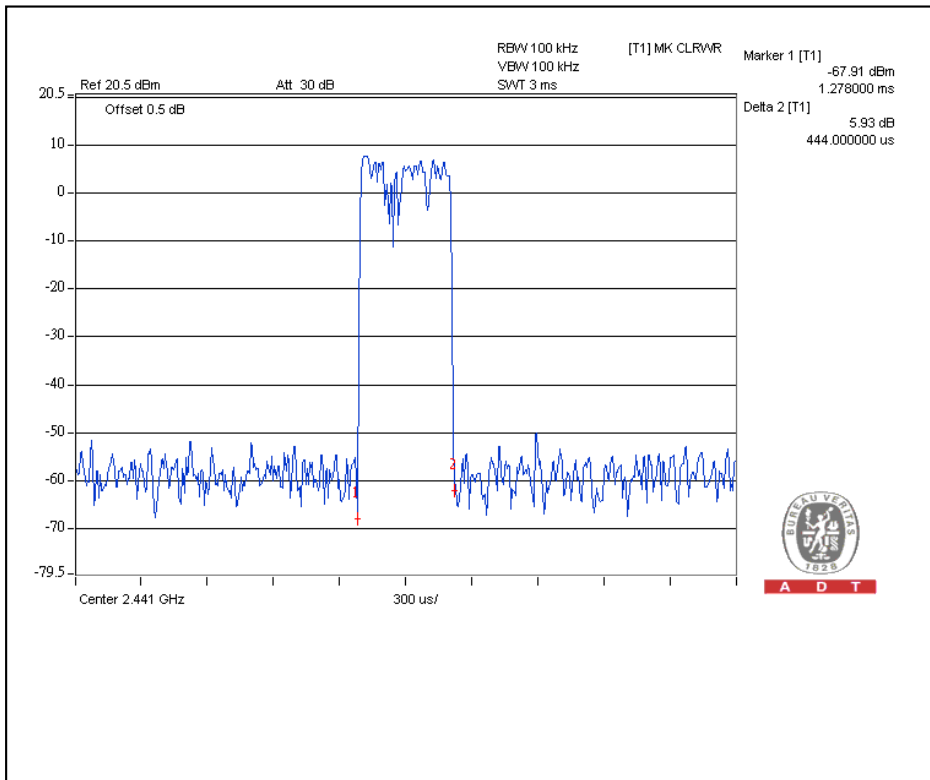
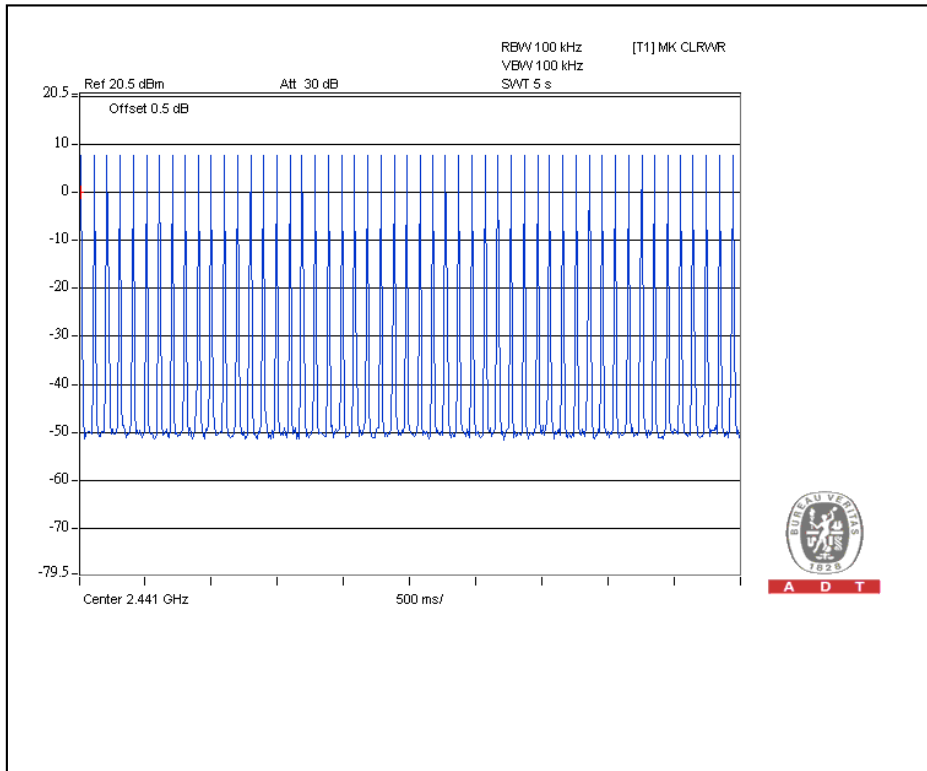

DH3



A D T

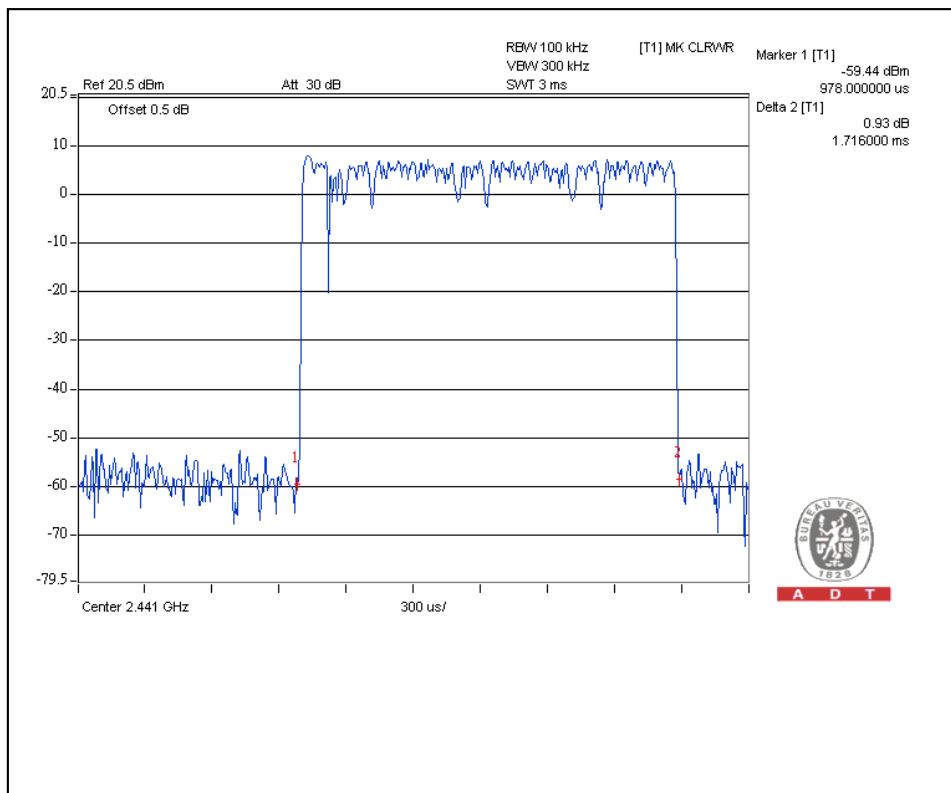
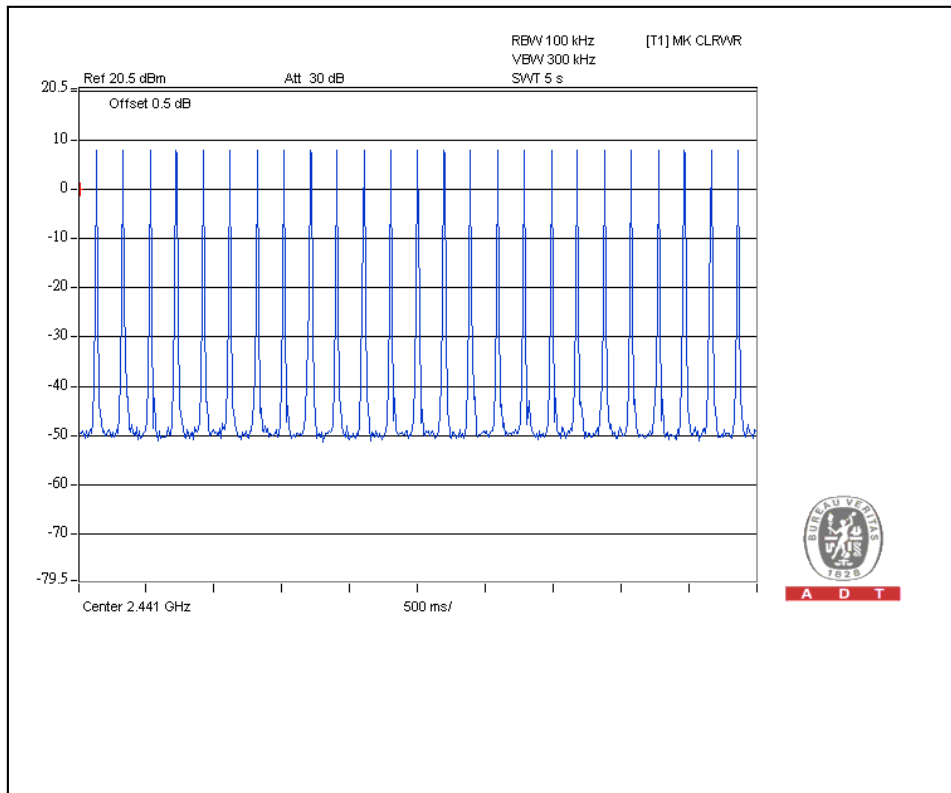

DH5



A D T

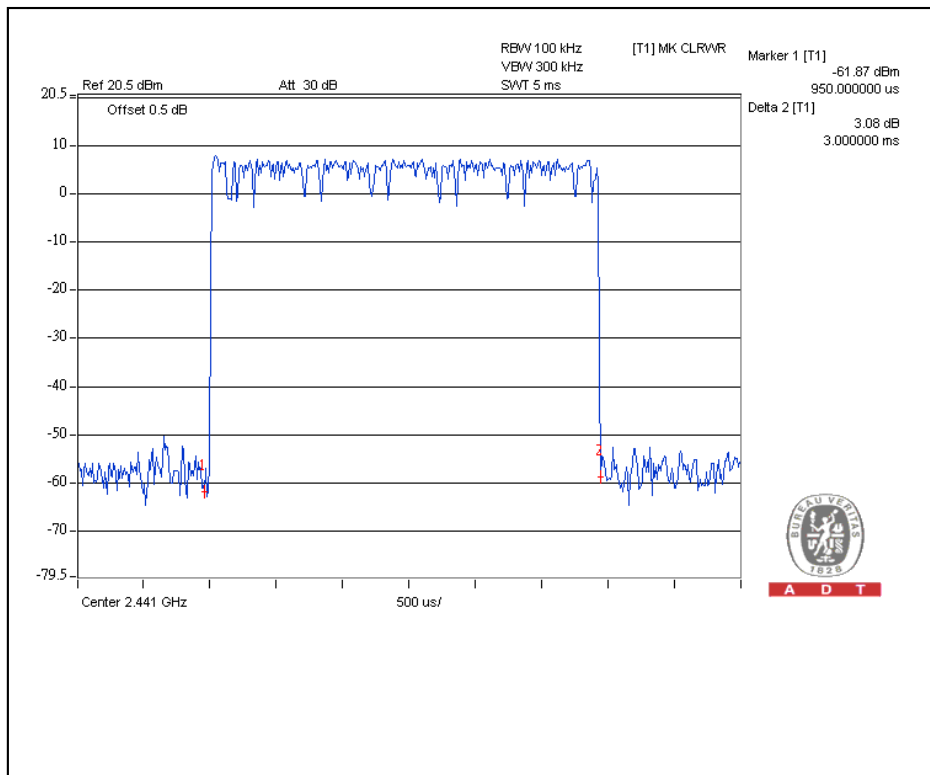
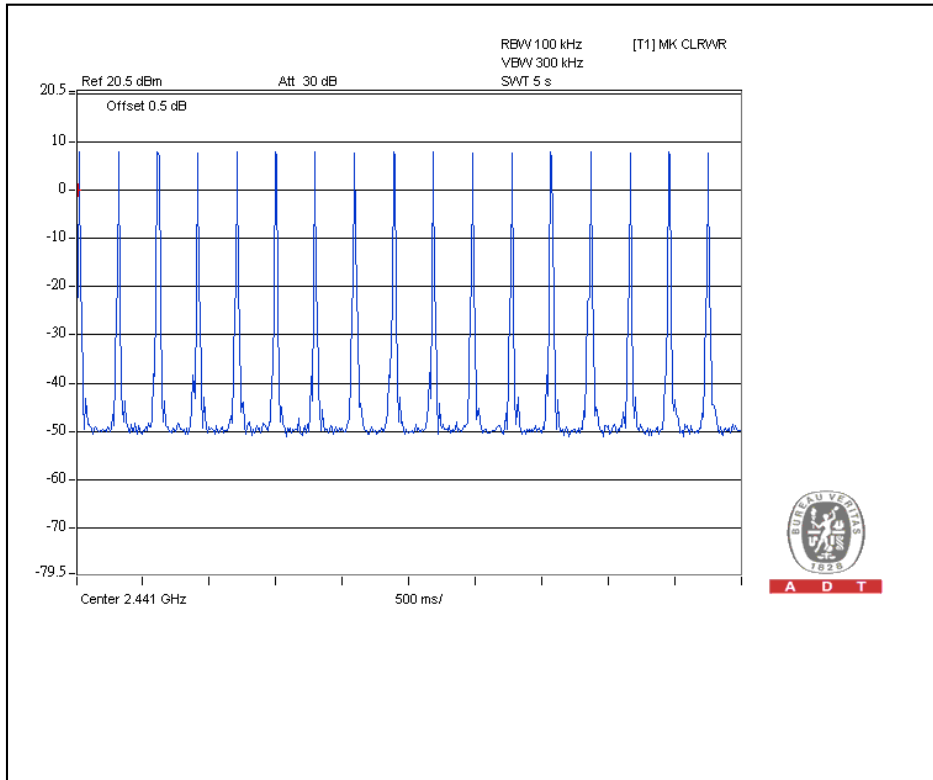

For $\pi/4$ -DQPSK :
DH1



A D T

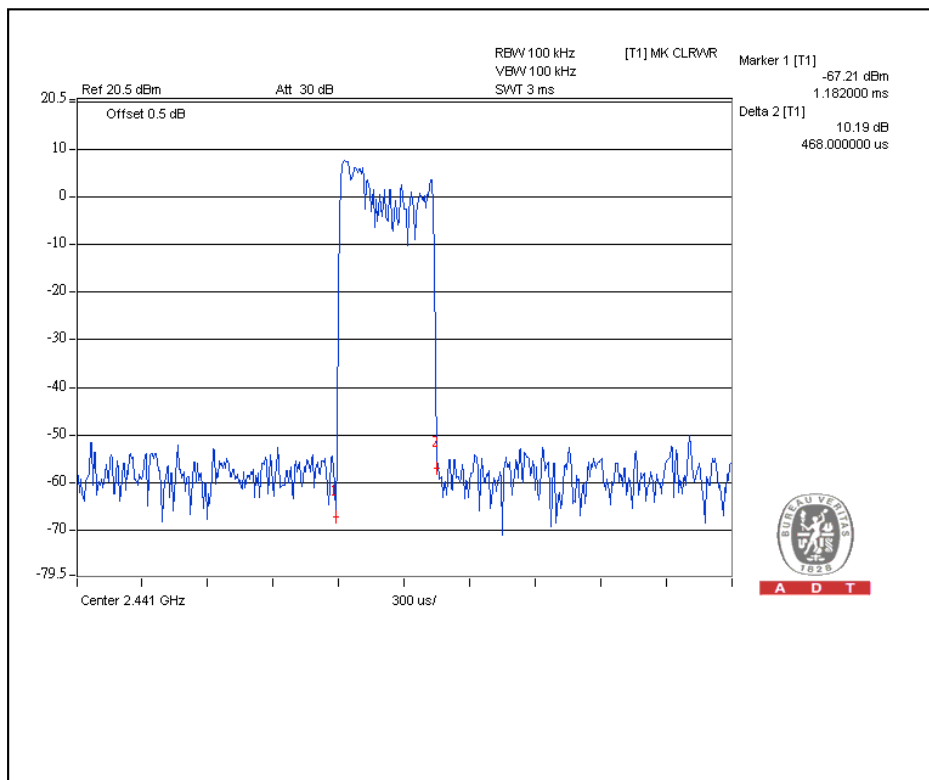
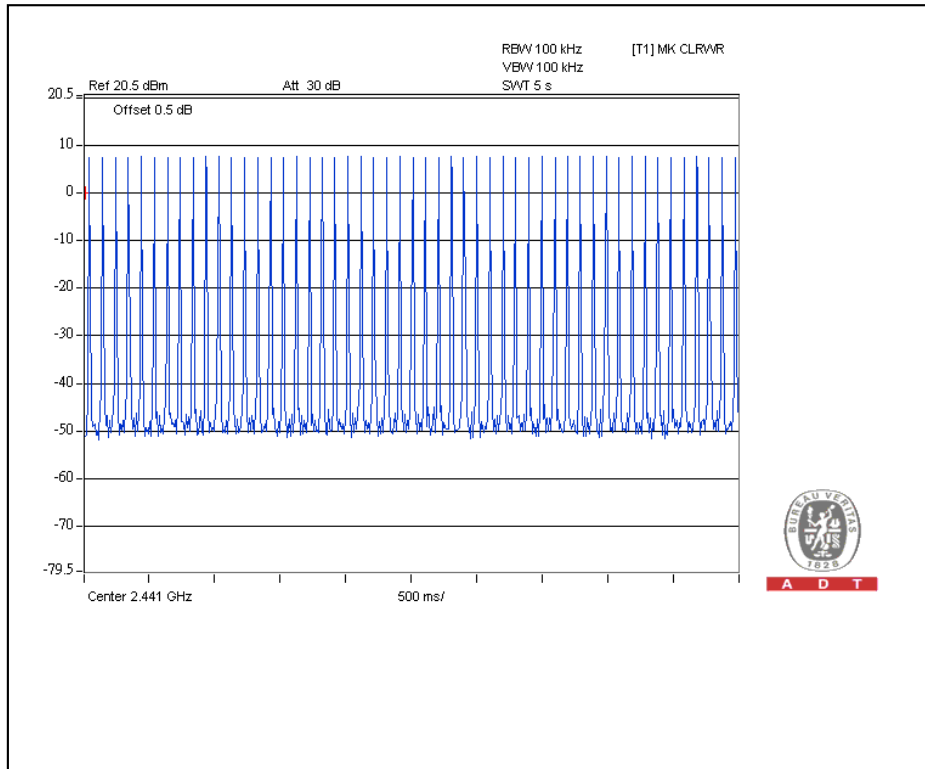

DH3



A D T

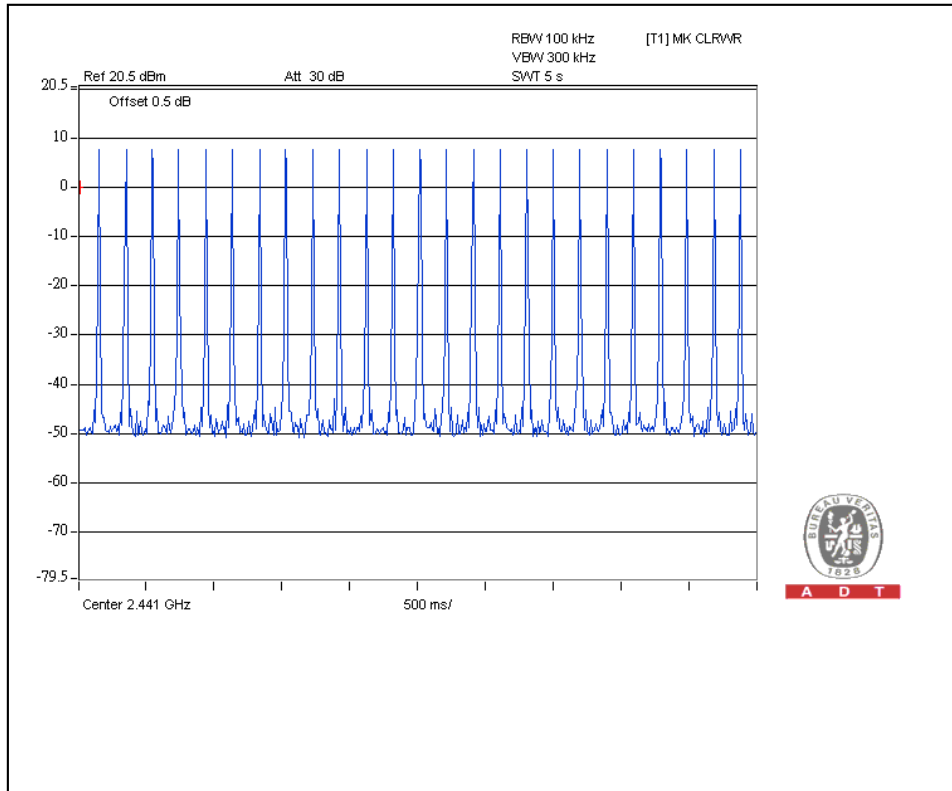

A D T

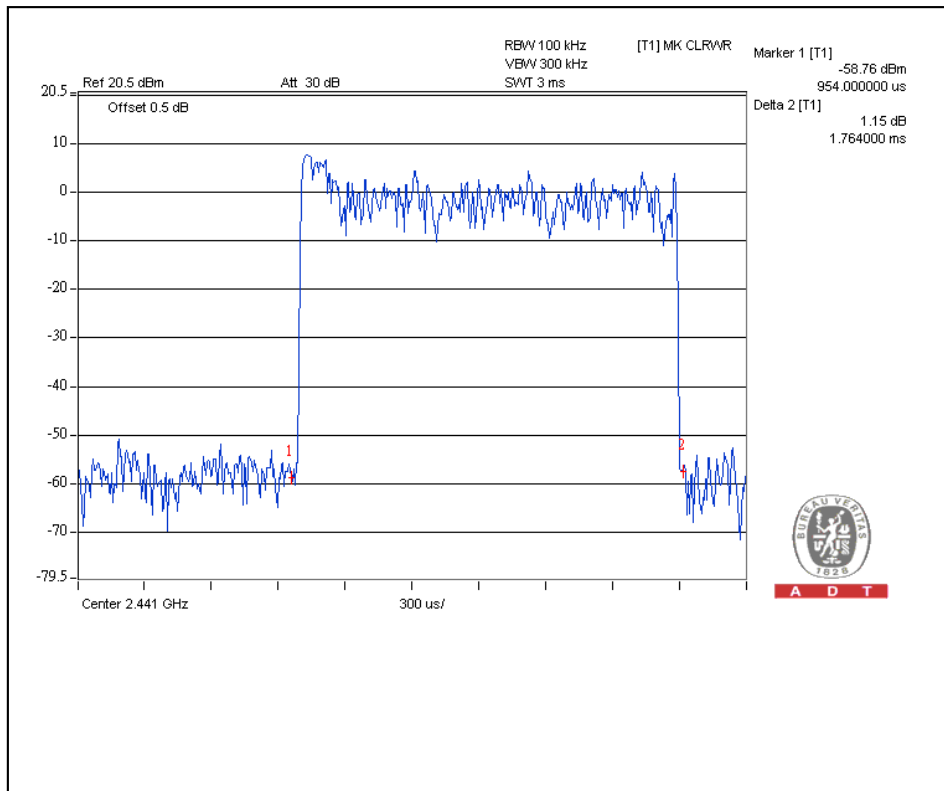

A D T

DH5



A D T

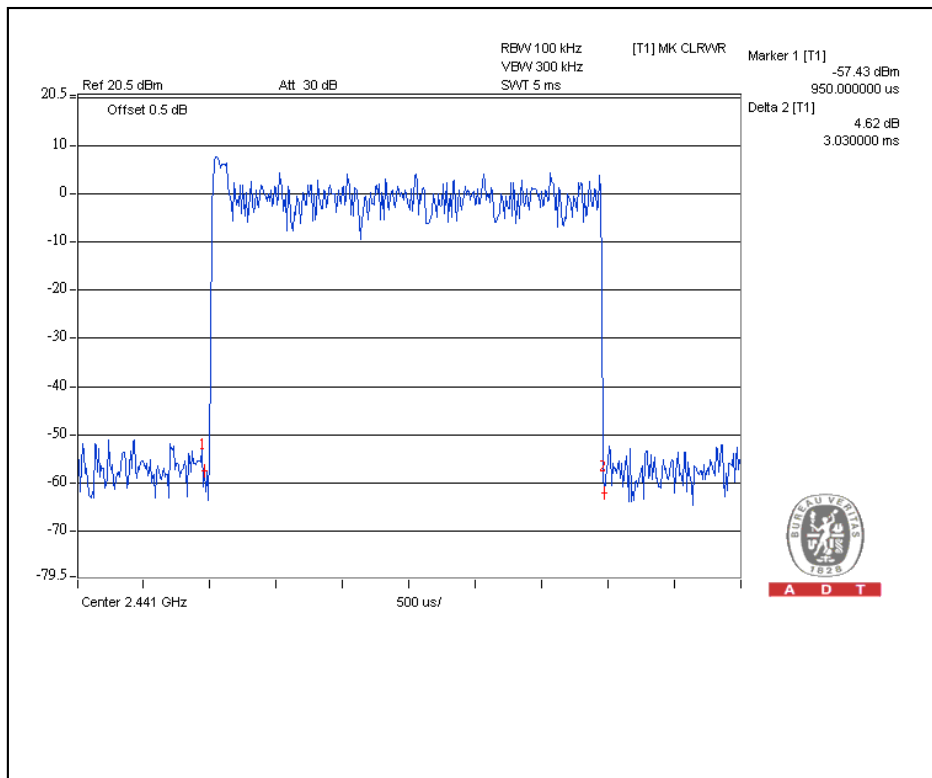
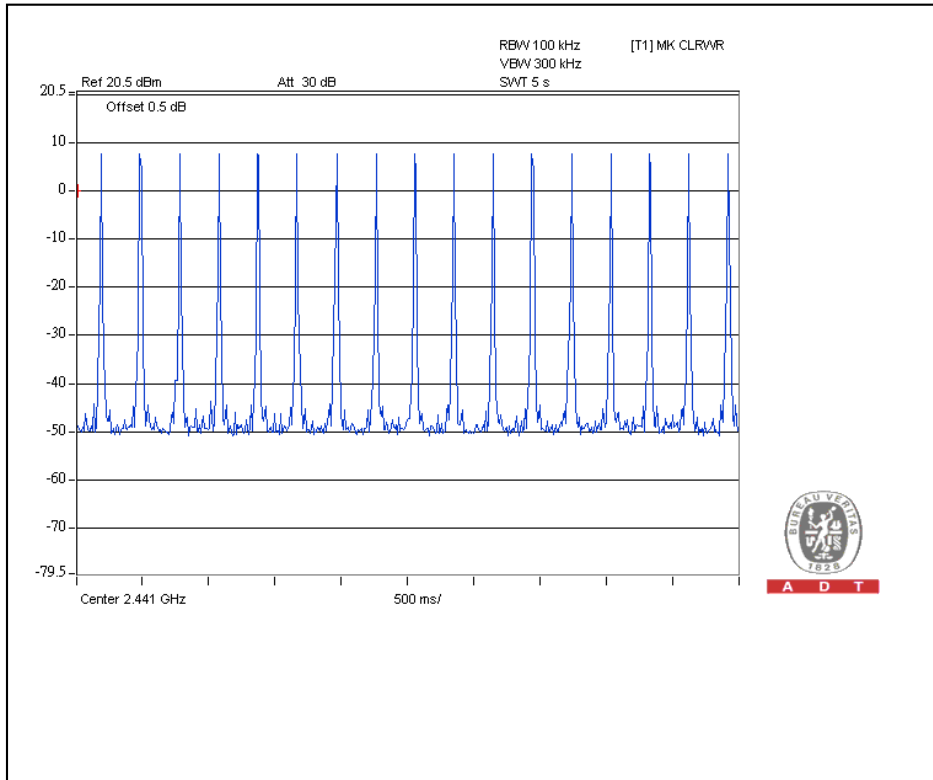

For 8DPSK :
DH1



A D T

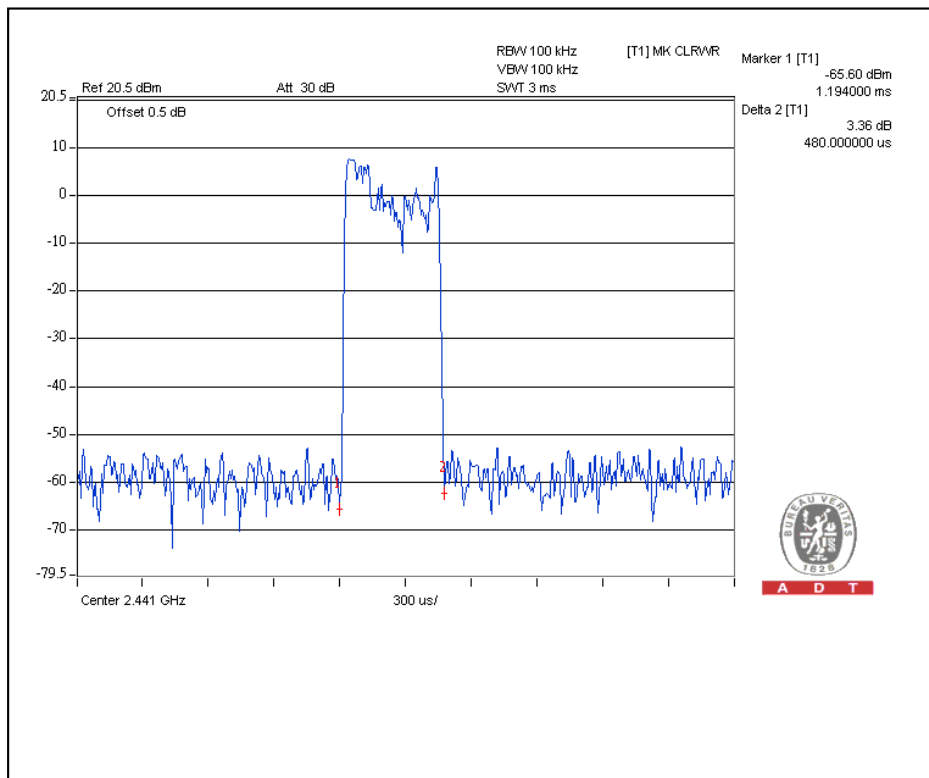
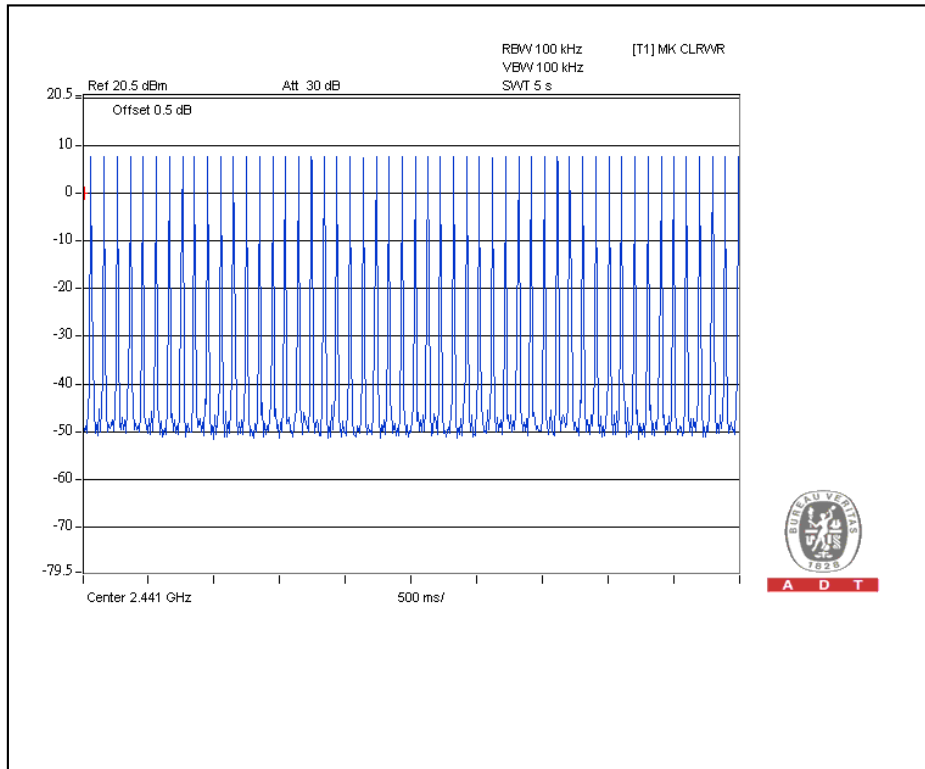

DH3



A D T

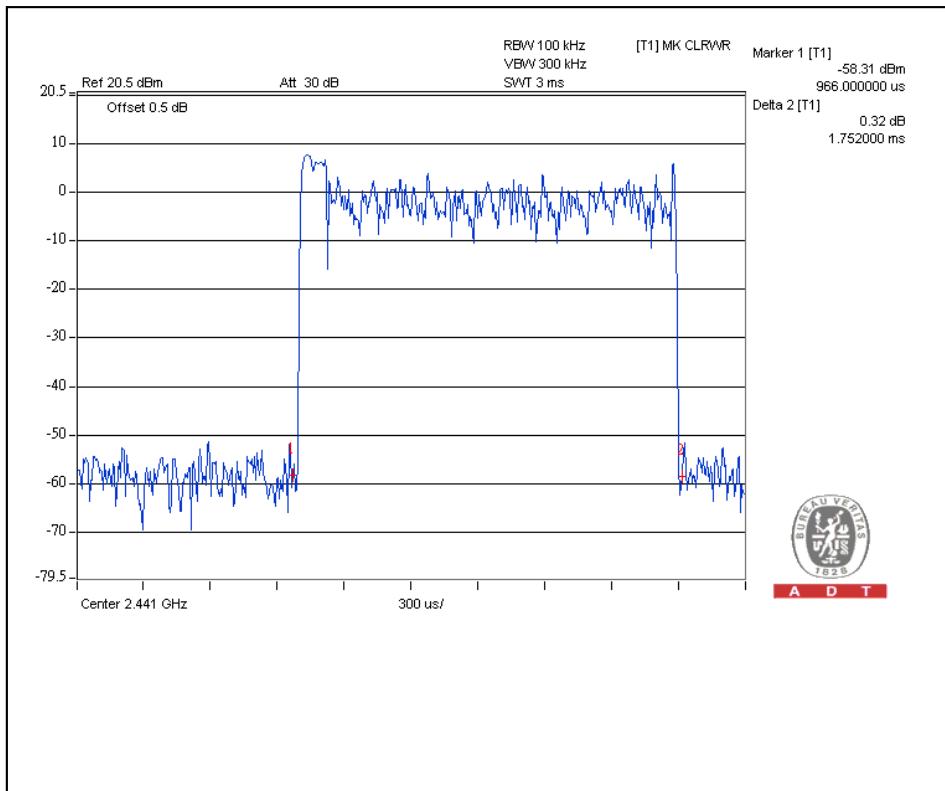
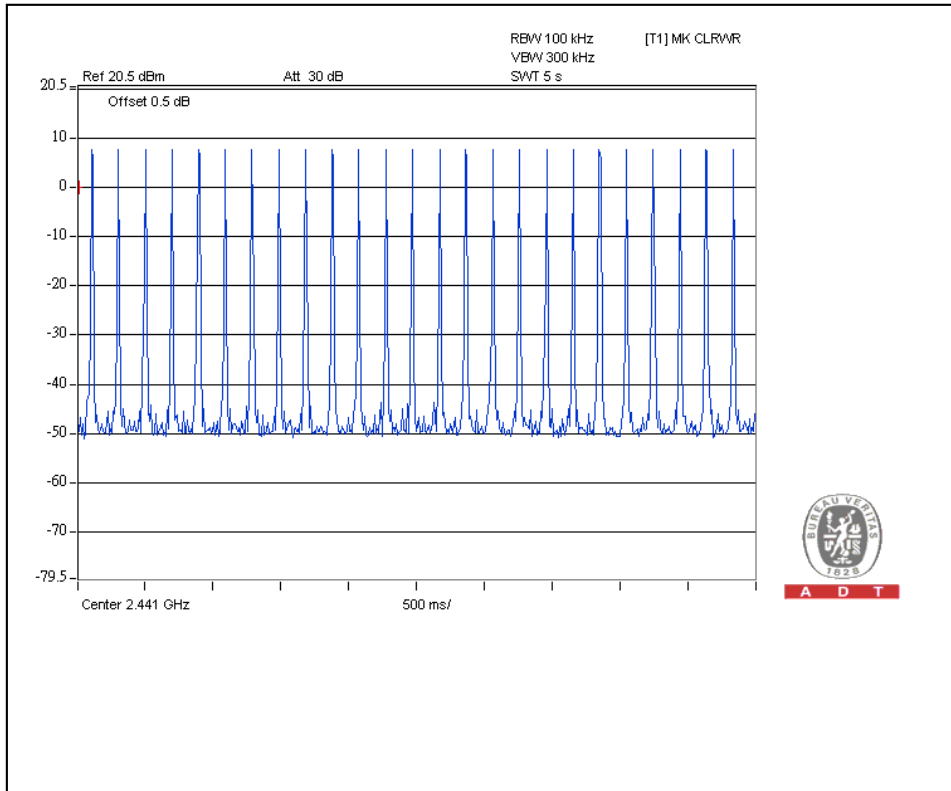

DH5



A D T

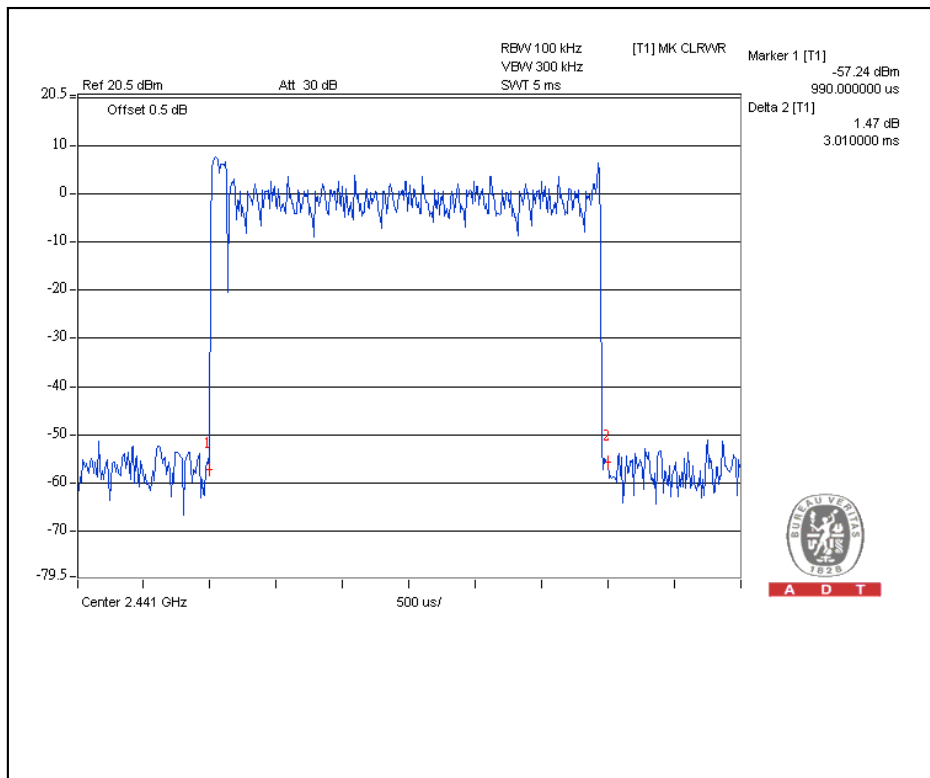
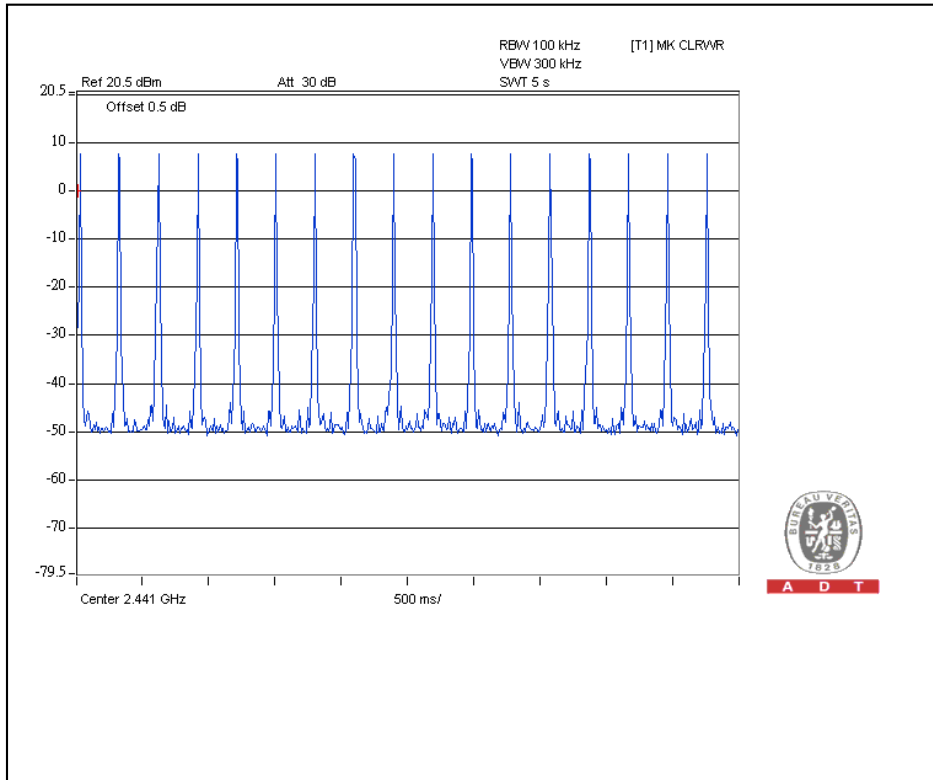



4.4 CHANNEL BANDWIDTH

4.4.1 LIMITS OF CHANNEL BANDWIDTH

For frequency hopping system operating in the 2400-2483.5MHz, If the two-thirds 20dB bandwidth of hopping channel is greater than 25kHz, two-thirds 20dB bandwidth of hopping channel shall be a minimum limit for the hopping channel separation.

4.4.2 TEST INSTRUMENTS

DESCRIPTION & MANUFACTURER	MODEL NO.	SERIAL NO.	CALIBRATED DATE	CALIBRATED UNTIL
R&S SPECTRUM ANALYZER	FSP40	100037	Aug. 09, 2009	Aug. 08, 2010

NOTE:

- 1.The calibration interval of the above test instruments is 12 months and the calibrations are traceable to NML/ROC and NIST/USA.

4.4.3 TEST PROCEDURE

1. Check the calibration of the measuring instrument using either an internal calibrator or a known signal from an external generator.
2. Turn on the EUT and connect it to measurement instrument. Then set it to any one convenient frequency within its operating range. Set a reference level on the measuring instrument equal to the highest peak value.
3. Measure the frequency difference of two frequencies that were attenuated 20dB from the reference level. Record the frequency difference as the emission bandwidth.
4. Repeat above procedures until all frequencies measured were complete.

4.4.4 DEVIATION FROM TEST STANDARD

No deviation

4.4.5 TEST SETUP

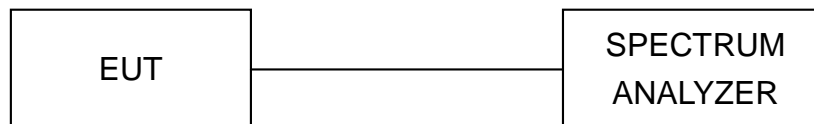

4.4.6 EUT OPERATING CONDITION

The software provided by client enabled the EUT to transmit and receive data at lowest, middle and highest channel frequencies individually.



A D T

4.4.7 TEST RESULTS

For GFSK :

CHANNEL	CHANNEL FREQUENCY (MHz)	20dB BANDWIDTH (MHz)
0	2402	0.87
39	2441	0.87
78	2480	0.85

Channel 0

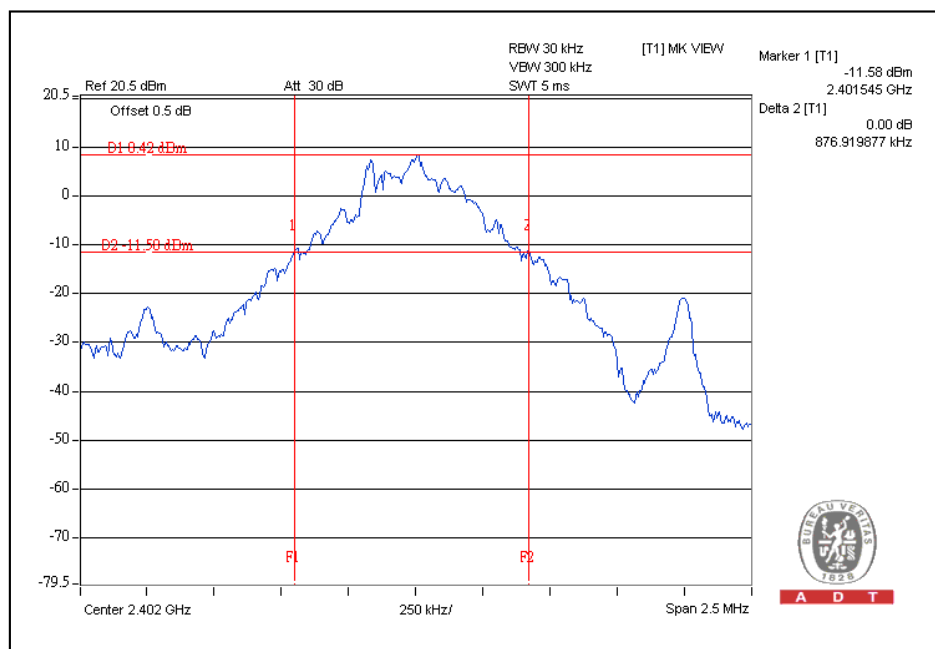



A D T

For $\pi/4$ -DQPSK :

CHANNEL	CHANNEL FREQUENCY (MHz)	20dB BANDWIDTH (MHz)
0	2402	1.20
39	2441	1.21
78	2480	1.25

Channel 78

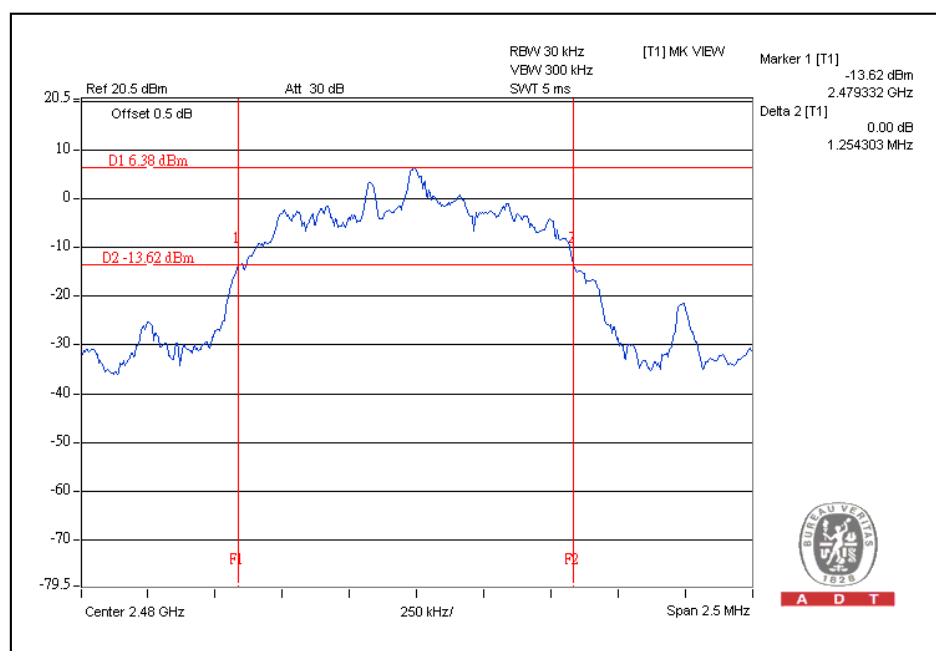



A D T

For 8DPSK :

CHANNEL	CHANNEL FREQUENCY (MHz)	20dB BANDWIDTH (MHz)
0	2402	1.21
39	2441	1.20
78	2480	1.23

Channel 78

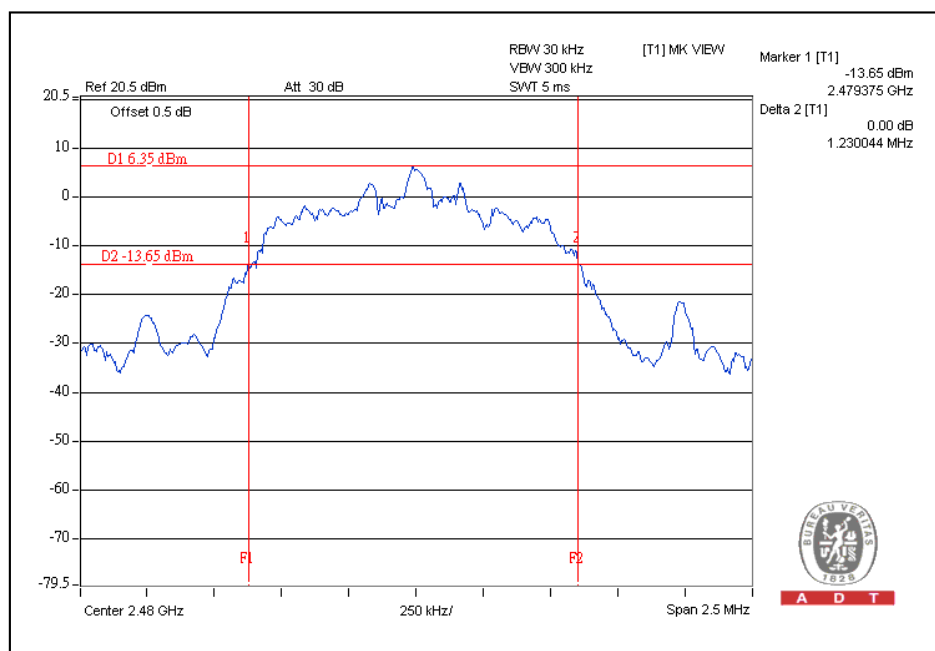



4.5 HOPPING CHANNEL SEPARATION

4.5.1 LIMIT OF HOPPING CHANNEL SEPARATION

At least 25 kHz or two-thirds of 20dB hopping channel bandwidth (whichever is greater).

4.5.2 TEST INSTRUMENTS

DESCRIPTION & MANUFACTURER	MODEL NO.	SERIAL NO.	CALIBRATED DATE	CALIBRATED UNTIL
R&S SPECTRUM ANALYZER	FSP40	100037	Aug. 09, 2009	Aug. 08, 2010

NOTE:

1. The calibration interval of the above test instruments is 12 months and the calibrations are traceable to NML/ROC and NIST/USA.

4.5.3 TEST PROCEDURES

1. Check the calibration of the measuring instrument using either an internal calibrator or a known signal from an external generator.
2. Turn on the EUT and connect it to measurement instrument. Then set it to any one convenient frequency within its operating range.
3. By using the MaxHold function record the separation of two adjacent channels.
4. Measure the frequency difference of these two adjacent channels by SA MARK function. And then plot the result on SA screen.
5. Repeat above procedures until all frequencies measured were complete.



A D T

4.5.4 DEVIATION FROM TEST STANDARD

No deviation

4.5.5 TEST SETUP

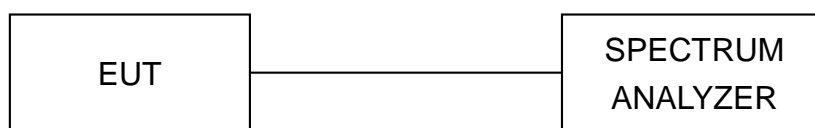



A D T

4.5.6 TEST RESULTS

For GFSK :

Channel	Frequency (MHz)	Adjacent Channel Separation (MHz)	Minimum Limit (MHz)	Pass / Fail
0	2402	1.007	0.580	PASS
39	2441	1.007	0.580	PASS
78	2480	1.007	0.567	PASS

The minimum limit is two-thirds of 20dB bandwidth. Test results please refer to below and next page.

Channel 0

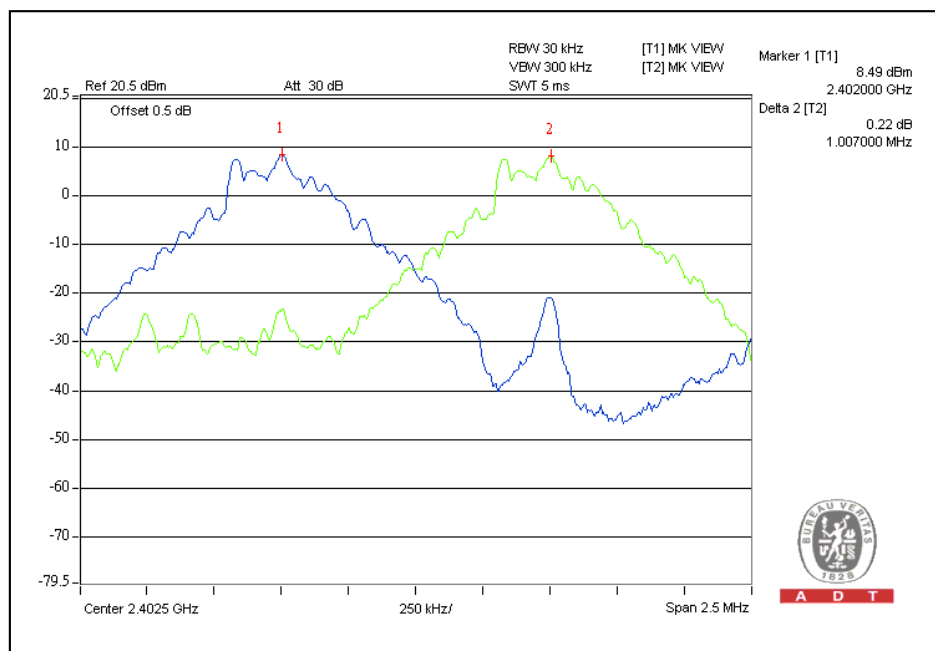



A D T

Channel 39

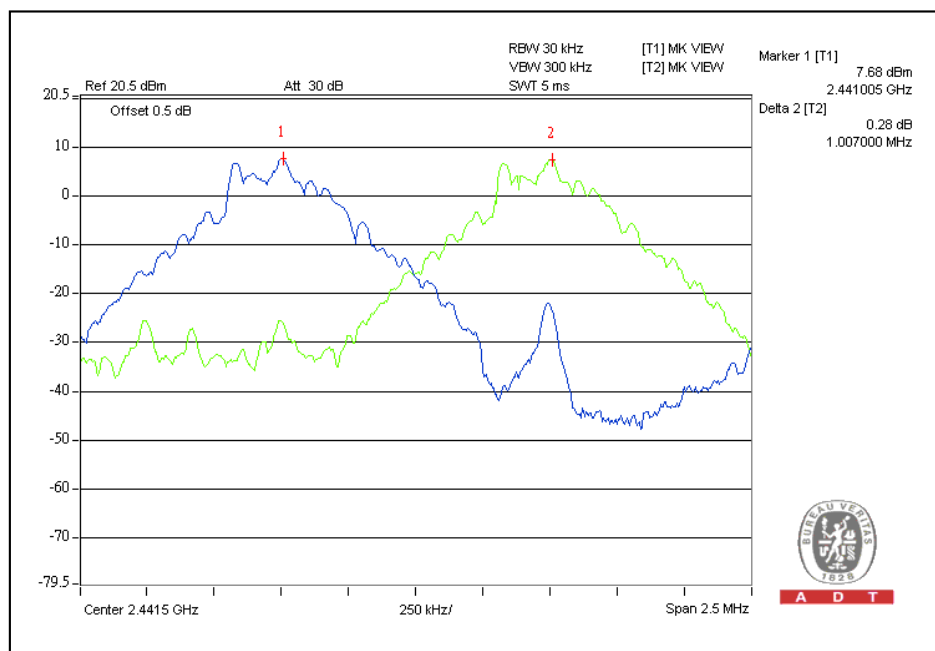

Channel 78

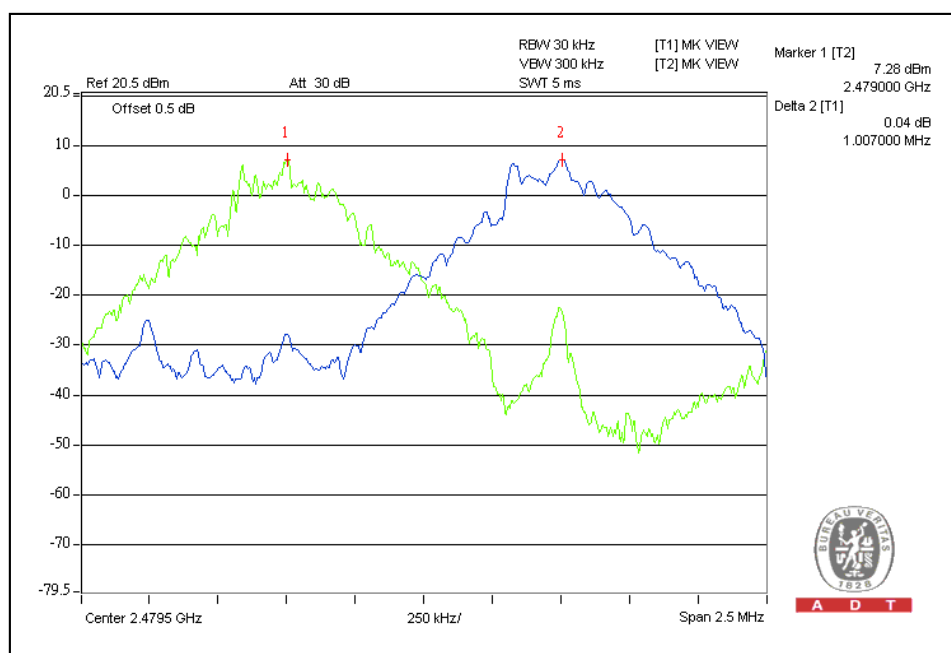



A D T

For $\pi/4$ -DQPSK :

Channel	Frequency (MHz)	Adjacent Channel Separation (MHz)	Minimum Limit (MHz)	Pass / Fail
0	2402	1.004	0.800	PASS
39	2441	1.003	0.807	PASS
78	2480	1.000	0.833	PASS

The minimum limit is two-thirds of 20dB bandwidth. Test results please refer to below and next page.

Channel 0

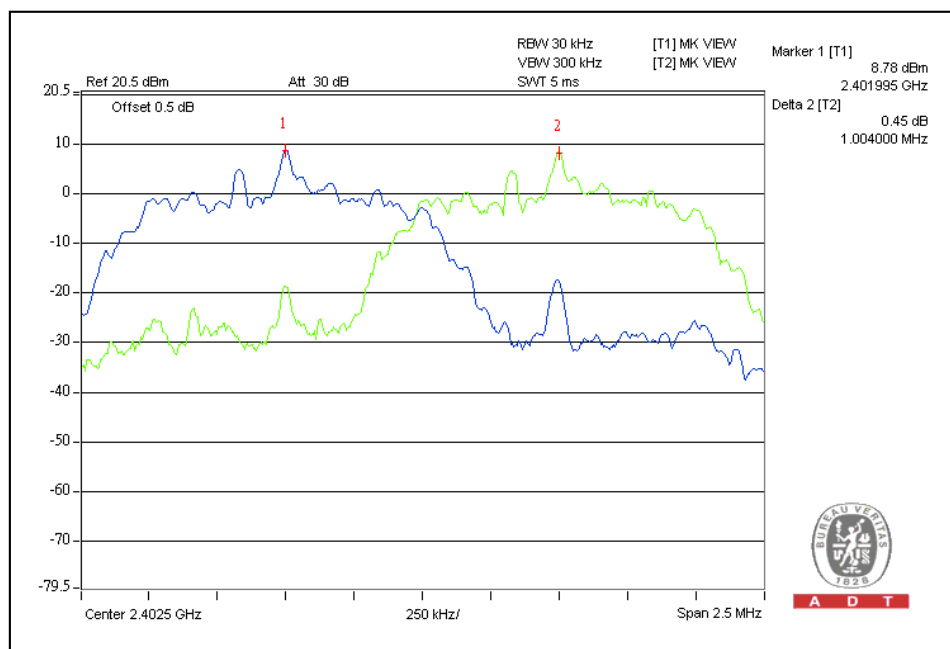



A D T

For 8DPSK :

Channel	Frequency (MHz)	Adjacent Channel Separation (MHz)	Minimum Limit (MHz)	Pass / Fail
0	2402	1.004	0.807	PASS
39	2441	1.004	0.800	PASS
78	2480	1.004	0.820	PASS

The minimum limit is two-thirds of 20dB bandwidth. Test results please refer to below and next page.

Channel 0

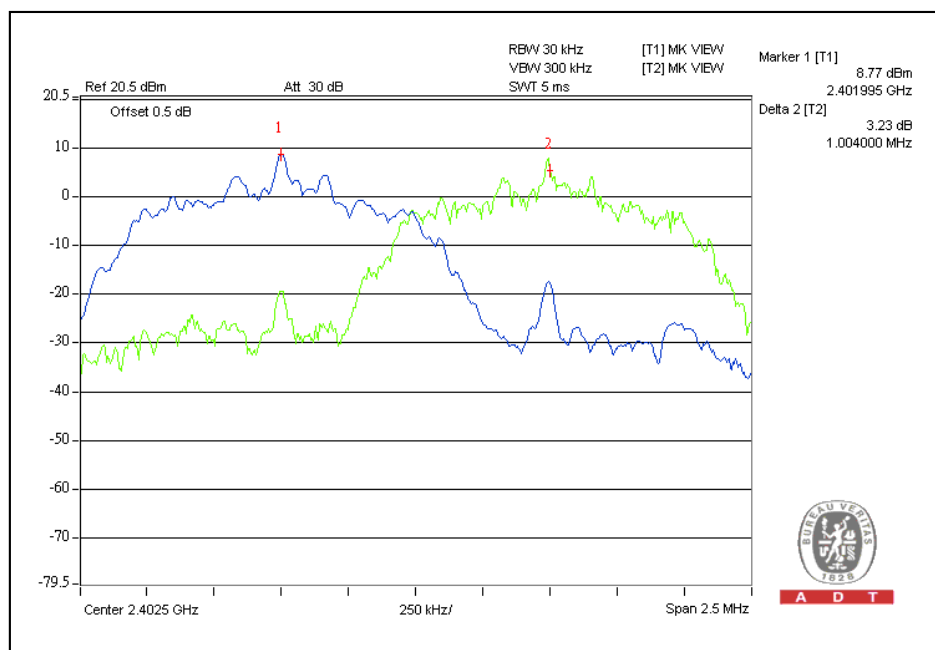



A D T

Channel 39

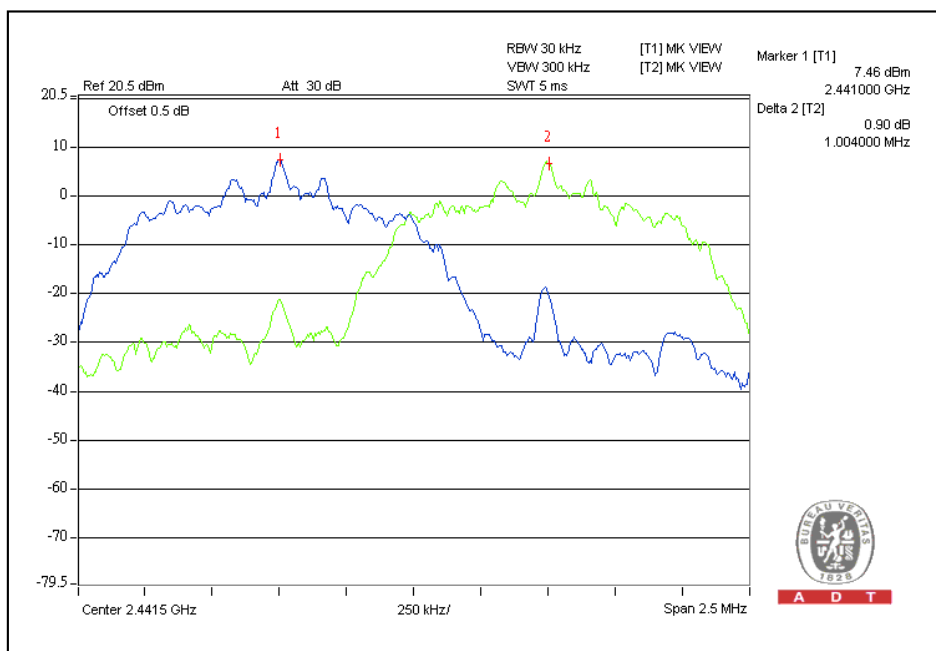

Channel 78

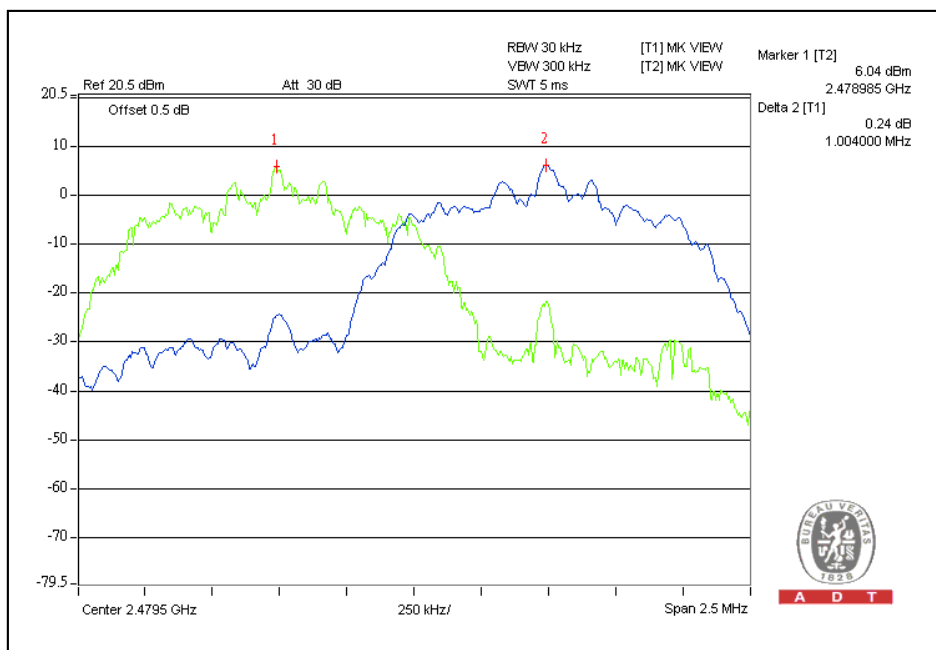



A D T

4.6 MAXIMUM PEAK OUTPUT POWER

4.6.1 LIMITS OF MAXIMUM PEAK OUTPUT POWER MEASUREMENT

The Maximum Peak Output Power Limit is 125mW.

4.6.2 INSTRUMENTS

DESCRIPTION & MANUFACTURER	MODEL NO.	SERIAL NO.	CALIBRATED DATE	CALIBRATED UNTIL
R&S SPECTRUM ANALYZER	FSP40	100037	Aug. 09, 2009	Aug. 08, 2010

NOTE:

1. The calibration interval of the above test instruments is 12 months and the calibrations are traceable to NML/ROC and NIST/USA.

4.6.3 TEST PROCEDURES

- a. Check the calibration of the measuring instrument using either an internal calibrator or a known signal from an external generator.
- b. Turn on the EUT and connect it to measurement instrument. Then set it to any one convenient frequency within its operating range. Set a reference level on the measuring instrument equal to the highest peak value.
- c. The center frequency of the spectrum analyzer is set to the fundamental frequency and using 3 MHz RBW and 3 MHz VBW.
- d. Measure the captured power within the band and recording the plot.
- e. Repeat above procedures until all frequencies measured were complete.

4.6.4 DEVIATION FROM TEST STANDARD

No deviation

4.6.5 TEST SETUP

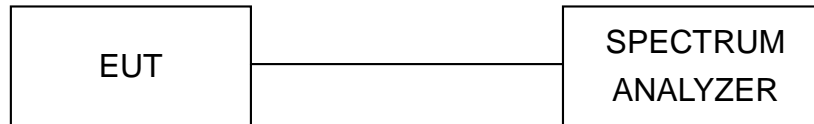

For the actual test configuration, please refer to the related Item – Photographs of the Test Configuration.

4.6.6 EUT OPERATING CONDITION

The software provided by client enabled the EUT to transmit and receive data at lowest, middle and highest channel frequencies individually.



A D T

4.6.7 TEST RESULTS

For GFSK :

CHANNEL	CHANNEL FREQUENCY (MHz)	PEAK POWER OUTPUT (mW)	PEAK POWER OUTPUT (dBm)	PEAK POWER LIMIT (mW)	PASS/FAIL
0	2402	7.9	9	125	PASS
39	2441	6.8	8.3	125	PASS
78	2480	6.3	8	125	PASS

Channel 0

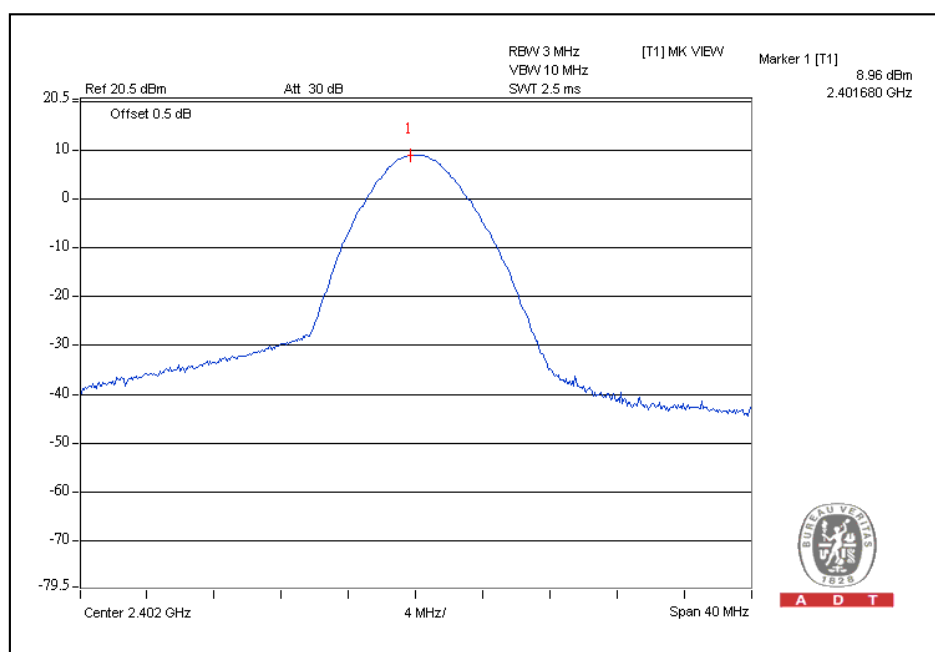



A D T

For $\pi/4$ -DQPSK :

CHANNEL	CHANNEL FREQUENCY (MHz)	PEAK POWER OUTPUT (mW)	PEAK POWER OUTPUT (dBm)	PEAK POWER LIMIT (mW)	PASS/FAIL
0	2402	9.1	9.6	125	PASS
39	2441	7.2	8.6	125	PASS
78	2480	6.6	8.2	125	PASS

Channel 0

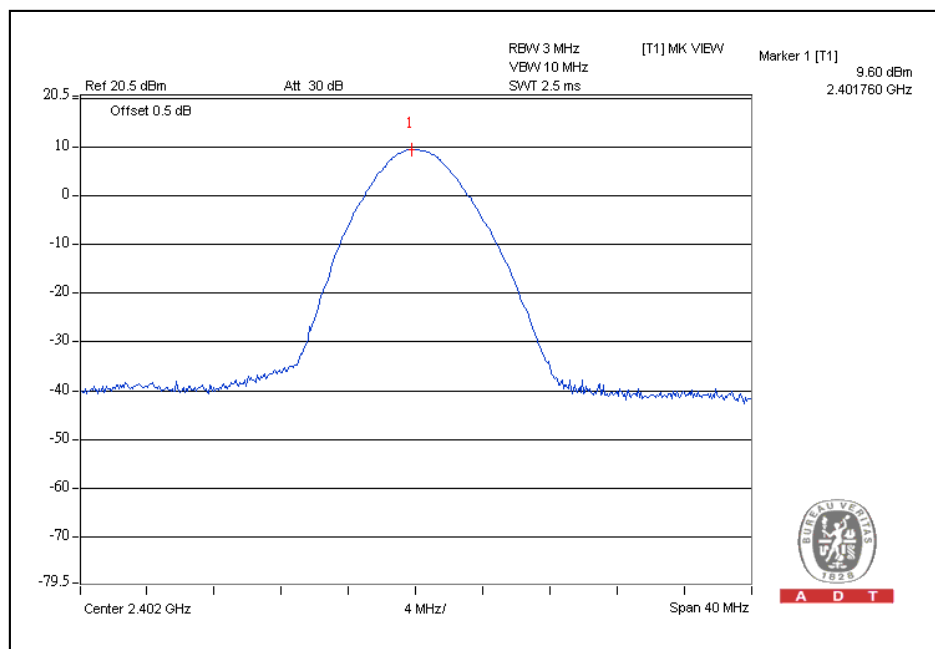



A D T

For 8DPSK :

CHANNEL	CHANNEL FREQUENCY (MHz)	PEAK POWER OUTPUT (mW)	PEAK POWER OUTPUT (dBm)	PEAK POWER LIMIT (mW)	PASS/FAIL
0	2402	9.5	9.8	125	PASS
39	2441	7.6	8.8	125	PASS
78	2480	6.8	8.3	125	PASS

Channel 0

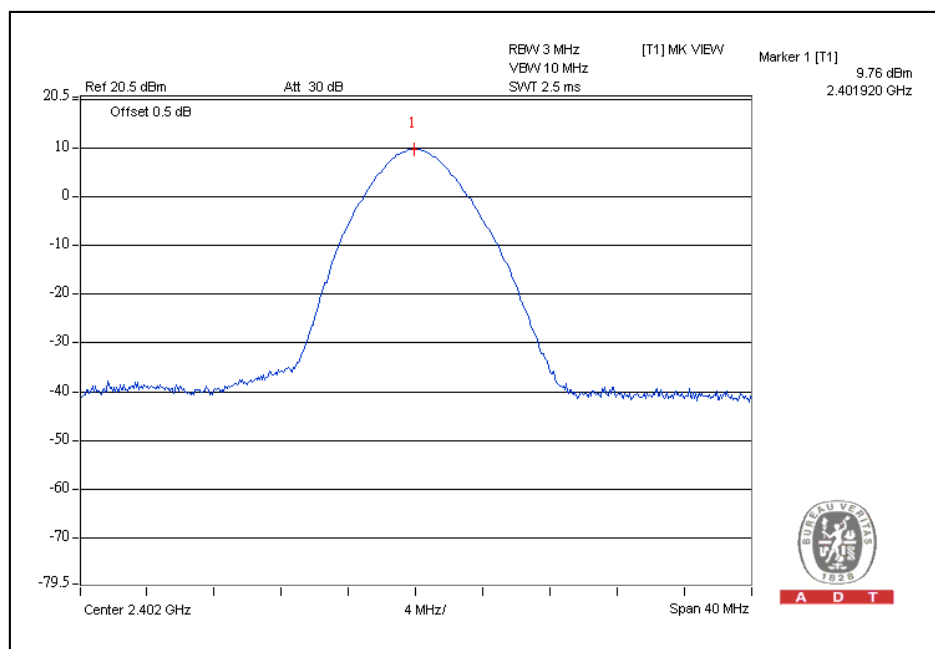



4.7 RADIATED EMISSION MEASUREMENT

4.7.1 LIMITS OF RADIATED EMISSION MEASUREMENT

Emissions radiated outside of the specified bands, shall be according to the general radiated limits in 15.209 as following:

FREQUENCIES (MHz)	FIELD STRENGTH (microvolts/meter)	MEASUREMENT DISTANCE (meters)
0.009 ~ 0.490	2400 / F(kHz)	300
0.490 ~ 1.705	24000 / F(kHz)	30
1.705 ~ 30.0	30	30
30 ~ 88	100	3
88 ~ 216	150	3
216 ~ 960	200	3
Above 960	500	3

NOTE:

1. The lower limit shall apply at the transition frequencies.
2. Emission level (dBuV/m) = 20 log Emission level (uV/m).
3. As shown in 15.35(b), for frequencies above 1000MHz, the field strength limits are based on average detector, however, the peak field strength of any emission shall not exceed the maximum permitted average limits, specified above by more than 20dB under any condition of modulation.



4.7.2 TEST INSTRUMENTS

DESCRIPTION & MANUFACTURER	MODEL NO.	SERIAL NO.	CALIBRATED DATE	CALIBRATED UNTIL
Agilent Spectrum Analyzer	E4446A	MY48250253	Aug. 03 , 2009	Aug. 02 , 2010
Agilent Pre-Selector	N9039A	MY46520311	Aug. 17 , 2009	Aug. 16 , 2010
Agilent Signal Generator	N5181A	MY49060517	July 20 , 2009	July 19 , 2010
Mini-Circuits Pre-Amplifier (Below 1GHz)	ZFL-1000VH2B	AMP-ZFL-03	Nov. 18 , 2009	Nov. 17, 2010
Agilent Pre-Amplifier(Above 1GHz)	8449B	3008A02578	July 06 , 2009	July 05 , 2010
Miteq Pre-Amplifier (15GH 以上)	AFS33-1800265 0-30-8P-44	881786	NA	NA
SCHWARZBECK Trilog Broadband Antenna	VULB 9168	9168-360	Sep.30 , 2009	Sep. 29 , 2010
AISI Horn_Antenna	AIH.8018	0000320091110	Nov. 16 , 2009	Nov. 15 , 2010
SCHWARZBECK Horn_Antenna	BBHA 9170	9170-424	Sep. 30 , 2009	Sep. 29 , 2010
RF CABLE	NA	RF104-201 RF104-203 RF104-204	Dec. 24, 2009	Dec. 23, 2010
RF Cable	NA	CHGCAB_001	NA	NA
Software	ADT_Radiated_ V8.7.05	NA	NA	NA
CT Antenna Tower & Turn Table	NA	NA	NA	NA

Note: 1. The calibration interval of the above test instruments is 12 months and the calibrations are traceable to NML/ROC and NIST/USA.

2. The test was performed in 966 Chamber No. G.

3. The FCC Site Registration No. is 966073.

4. The CANADA Site Registration No. is IC 7450H-2.



A D T

4.7.3 TEST PROCEDURES

- a. The EUT was placed on the top of a rotating table 0.8 meters above the ground at 3 meters chamber room. The table was rotated 360 degrees to determine the position of the highest radiation.
- b. The EUT was set 3 meters away from the interference-receiving antenna, which was mounted on the top of a variable-height antenna tower.
- c. The antenna is a broadband antenna, and its height is varied from one meter to four meters above the ground to determine the maximum value of the field strength. Both horizontal and vertical polarizations of the antenna are set to make the measurement.
- d. For each suspected emission, the EUT was arranged to its worst case and then the antenna was tuned to heights from 1 meter to 4 meters and the rotatable table was turned from 0 degrees to 360 degrees to find the maximum reading.
- e. The test-receiver system was set to peak and average detect function and specified bandwidth with maximum hold mode when the test frequency is above 1 GHz.

NOTE:

1. The resolution bandwidth and video bandwidth of test receiver/spectrum analyzer is 120kHz for Quasi-peak detection (QP) at frequency below 1GHz.
2. The resolution bandwidth is 1MHz and video bandwidth of test receiver/spectrum analyzer is 3MHz for Peak detection at frequency above 1GHz. The resolution bandwidth of test receiver/spectrum analyzer is 1 MHz for Average detection (AV) at frequency above 1GHz.
3. For measurement of frequency above 1000 MHz, the EUT was set 3 meters away from the interference-receiving antenna.

4.7.4 DEVIATION FROM TEST STANDARD

No deviation

4.7.5 TEST SETUP

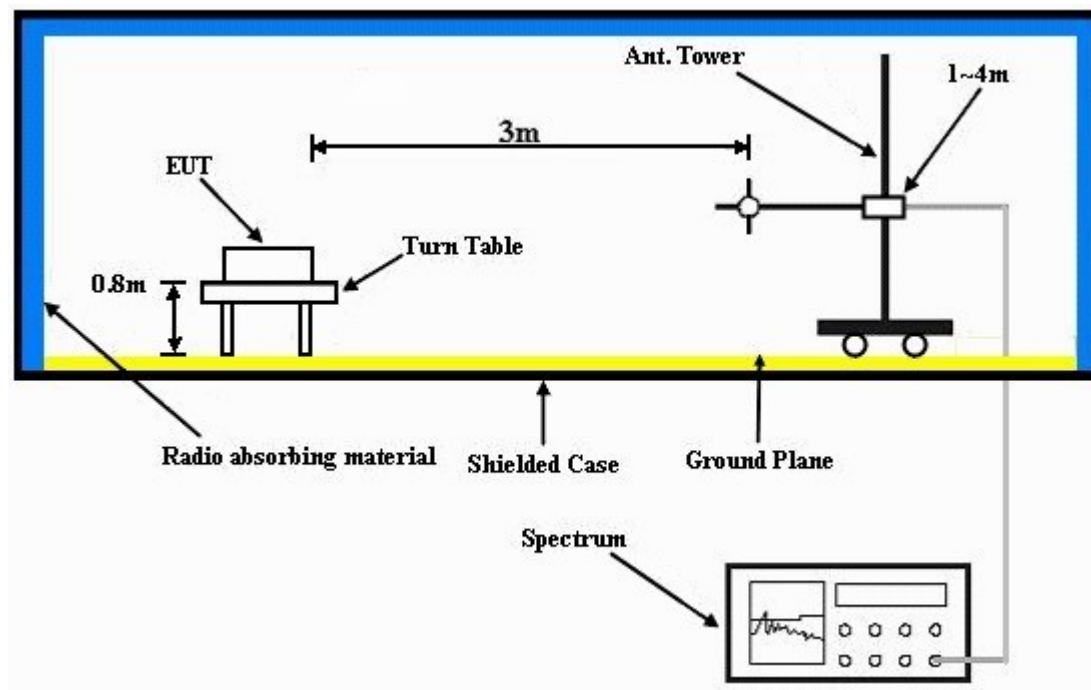

For the actual test configuration, please refer to the related item – Photographs of the Test Configuration.

4.7.6 EUT OPERATING CONDITIONS

3. Connect the EUT with the support unit 1 (Notebook Computer) which placed on a testing table.
4. The communication partner run test program “CSR Blue Test” to enable EUT under transmission/receiving condition continuously at specific channel frequency.



A D T

Below 1GHz Test Data**4.7.7 TEST RESULTS****BELOW 1GHz WORST-CASE DATA : GFSK MODULATION**

EUT TEST CONDITION		MEASUREMENT DETAIL	
CHANNEL	Channel 0	FREQUENCY RANGE	Below 1000MHz
INPUT POWER (SYSTEM)	120Vac, 60 Hz	DETECTOR FUNCTION	Quasi-Peak
ENVIRONMENTAL CONDITIONS	20deg. C, 65%RH 1023 hPa	TESTED BY	Rex Huang

ANTENNA POLARITY & TEST DISTANCE: HORIZONTAL AT 3 M								
NO.	FREQ. (MHz)	EMISSION LEVEL (dBuV/m)	LIMIT (dBuV/m)	MARGIN (dB)	ANTENNA HEIGHT (m)	TABLE ANGLE (Degree)	RAW VALUE (dBuV)	CORRECTION FACTOR (dB/m)
1	51.67	24.8 QP	40.00	-15.2	3.00 H	66	11.32	13.47
2	278.13	37.8 QP	46.00	-8.2	1.21 H	65	24.08	13.76
3	309.36	37.9 QP	46.00	-8.1	1.00 H	46	23.23	14.70
4	387.04	36.9 QP	46.00	-9.1	1.00 H	360	20.12	16.74
5	499.78	33.6 QP	46.00	-12.4	1.50 H	0	14.36	19.28
6	640.00	33.4 QP	46.00	-12.6	1.50 H	0	11.10	22.28
7	949.20	37.8 QP	46.00	-8.2	1.50 H	303	11.31	26.52
ANTENNA POLARITY & TEST DISTANCE: VERTICAL AT 3 M								
NO.	FREQ. (MHz)	EMISSION LEVEL (dBuV/m)	LIMIT (dBuV/m)	MARGIN (dB)	ANTENNA HEIGHT (m)	TABLE ANGLE (Degree)	RAW VALUE (dBuV)	CORRECTION FACTOR (dB/m)
1	51.67	36.3 QP	40.00	-3.7	1.00 V	80	22.87	13.47
2	239.96	29.6 QP	46.00	-16.5	2.00 V	344	17.14	12.41
3	277.38	39.5 QP	46.00	-6.5	2.00 V	322	25.77	13.74
4	412.86	34.1 QP	46.00	-11.9	1.50 V	360	16.72	17.36
5	480.01	29.1 QP	46.00	-16.9	1.00 V	5	10.24	18.83
6	640.00	31.8 QP	46.00	-14.2	1.00 V	257	9.49	22.28
7	953.82	40.9 QP	46.00	-5.1	1.00 V	337	14.37	26.56

REMARKS: 1. Emission level (dBuV/m) = Raw Value (dBuV) + Correction Factor (dB/m).

2. Correction Factor (dB/m) = Antenna Factor (dB/m) + Cable Factor (dB).

3. The other emission levels were very low against the limit.

4. Margin value = Emission level – Limit value.



Above 1GHz Test Data

4.7.8 TEST RESULTS

GFSK MODULATION

EUT TEST CONDITION		MEASUREMENT DETAIL	
CHANNEL	Channel 0	FREQUENCY RANGE	1 ~ 25GHz
INPUT POWER (SYSTEM)	120Vac, 60 Hz	DETECTOR FUNCTION	Peak (PK) Average (AV)
ENVIRONMENTAL CONDITIONS	19deg. C, 71%RH 1023 hPa	TESTED BY	Rex Huang

ANTENNA POLARITY & TEST DISTANCE: HORIZONTAL AT 3 M								
NO.	FREQ. (MHz)	EMISSION LEVEL (dBuV/m)	LIMIT (dBuV/m)	MARGIN (dB)	ANTENNA HEIGHT (m)	TABLE ANGLE (Degree)	RAW VALUE (dBuV)	CORRECTION FACTOR (dB/m)
1	1602.00	53.5 PK	74.00	-20.5	1.00 H	270	25.15	28.35
2	1602.00	23.4 AV	54.00	-30.6	1.00 H	270	-4.95	28.35
3	2338.20	59.7 PK	74.00	-14.3	1.00 H	268	28.22	31.49
4	2338.20	29.6 AV	54.00	-24.4	1.00 H	268	-1.88	31.49
5	*2402.00	109.5 PK			1.00 H	268	77.80	31.70
6	*2402.00	79.4 AV			1.00 H	268	47.71	31.70
7	4824.00	64.1 PK	74.00	-9.9	1.00 H	113	25.12	38.98
8	4824.00	34.0 AV	54.00	-20.0	1.00 H	113	-4.98	38.98
ANTENNA POLARITY & TEST DISTANCE: VERTICAL AT 3 M								
NO.	FREQ. (MHz)	EMISSION LEVEL (dBuV/m)	LIMIT (dBuV/m)	MARGIN (dB)	ANTENNA HEIGHT (m)	TABLE ANGLE (Degree)	RAW VALUE (dBuV)	CORRECTION FACTOR (dB/m)
1	1602.00	47.3 PK	74.00	-26.7	1.06 V	252	18.95	28.35
2	1602.00	17.2 AV	54.00	-36.8	1.06 V	252	-11.15	28.35
3	2389.10	56.4 PK	74.00	-17.6	1.00 V	59	24.73	31.66
4	2389.10	26.3 AV	54.00	-27.7	1.00 V	59	-5.37	31.66
5	*2402.00	103.1 PK			1.00 V	59	71.40	31.70
6	*2402.00	73.0 AV			1.00 V	59	41.30	31.70
7	4824.00	65.8 PK	74.00	-8.2	1.12 V	291	26.82	38.98
8	4824.00	35.7 AV	54.00	-18.3	1.12 V	291	-3.27	38.98

- REMARKS:**
1. Emission level (dBuV/m) = Raw Value (dBuV) + Correction Factor (dB/m).
 2. Correction Factor (dB/m) = Antenna Factor (dB/m) + Cable Factor (dB).
 3. The other emission levels were very low against the limit.
 4. Margin value = Emission level – Limit value.
 5. “ * “: Fundamental frequency.
 6. The DH5 packet was the worse case duty cycle for a transmit dwell time on a channel, based upon bluetooth theory the transmitter is on 0.625 * 5 per 296.25 ms per channel. Therefore, the duty cycle correlation factor be equal to: $20\log(3.125 / 100) = -30.1$ dB.
 7. Average value = peak reading + $20\log(\text{duty cycle})$.



EUT TEST CONDITION		MEASUREMENT DETAIL	
CHANNEL	Channel 39	FREQUENCY RANGE	1 ~ 25GHz
INPUT POWER (SYSTEM)	120Vac, 60 Hz	DETECTOR FUNCTION	Peak (PK) Average (AV)
ENVIRONMENTAL CONDITIONS	19deg. C, 71%RH 1023 hPa	TESTED BY	Rex Huang

ANTENNA POLARITY & TEST DISTANCE: HORIZONTAL AT 3 M								
NO.	FREQ. (MHz)	EMISSION LEVEL (dBuV/m)	LIMIT (dBuV/m)	MARGIN (dB)	ANTENNA HEIGHT (m)	TABLE ANGLE (Degree)	RAW VALUE (dBuV)	CORRECTION FACTOR (dB/m)
1	*2441.00	107.6 PK			1.00 H	266	75.77	31.83
2	*2441.00	77.5 AV			1.00 H	266	45.67	31.83
3	4882.00	62.4 PK	74.00	-11.6	1.07 H	115	23.23	39.17
4	4882.00	32.3 AV	54.00	-21.7	1.07 H	115	-6.87	39.17
5	7323.00	55.1 PK	74.00	-18.9	1.00 H	207	8.47	46.63
6	7323.00	25.0 AV	54.00	-29.0	1.00 H	207	-21.63	46.63

ANTENNA POLARITY & TEST DISTANCE: VERTICAL AT 3 M								
NO.	FREQ. (MHz)	EMISSION LEVEL (dBuV/m)	LIMIT (dBuV/m)	MARGIN (dB)	ANTENNA HEIGHT (m)	TABLE ANGLE (Degree)	RAW VALUE (dBuV)	CORRECTION FACTOR (dB/m)
1	*2441.00	100.3 PK			1.00 V	60	68.47	31.83
2	*2441.00	70.2 AV			1.00 V	60	38.37	31.83
3	4882.00	63.4 PK	74.00	-10.6	1.11 V	293	24.23	39.17
4	4882.00	33.3 AV	54.00	-20.7	1.11 V	293	-5.87	39.17
5	7323.00	55.4 PK	74.00	-18.6	1.18 V	129	8.77	46.63
6	7323.00	25.3 AV	54.00	-28.7	1.18 V	129	-21.33	46.63

- REMARKS:**
- Emission level (dBuV/m) = Raw Value (dBuV) + Correction Factor (dB/m).
 - Correction Factor (dB/m) = Antenna Factor (dB/m) + Cable Factor (dB).
 - The other emission levels were very low against the limit.
 - Margin value = Emission level – Limit value.
 - * *: Fundamental frequency.
 - The DH5 packet was the worse case duty cycle for a transmit dwell time on a channel, based upon bluetooth theory the transmitter is on 0.625 * 5 per 296.25 ms per channel. Therefore, the duty cycle correlation factor be equal to: $20\log(3.125 / 100) = -30.1$ dB.
 - Average value = peak reading + 20log(duty cycle).



EUT TEST CONDITION		MEASUREMENT DETAIL	
CHANNEL	Channel 78	FREQUENCY RANGE	1 ~ 25GHz
INPUT POWER (SYSTEM)	120Vac, 60 Hz	DETECTOR FUNCTION	Peak (PK) Average (AV)
ENVIRONMENTAL CONDITIONS	19deg. C, 71%RH 1023 hPa	TESTED BY	Rex Huang

ANTENNA POLARITY & TEST DISTANCE: HORIZONTAL AT 3 M								
NO.	FREQ. (MHz)	EMISSION LEVEL (dBuV/m)	LIMIT (dBuV/m)	MARGIN (dB)	ANTENNA HEIGHT (m)	TABLE ANGLE (Degree)	RAW VALUE (dBuV)	CORRECTION FACTOR (dB/m)
1	*2480.00	106.90 PK			1.00 H	267	74.94	31.96
2	*2480.00	76.80 AV			1.00 H	267	44.84	31.96
3	2483.50	63.37 PK	74.00	-10.63	1.00 H	267	31.40	31.97
4	2483.50	33.27 AV	54.00	-20.73	1.00 H	267	1.30	31.97
5	4960.00	62.90 PK	74.00	-11.10	1.05 H	113	23.47	39.43
6	4960.00	32.80 AV	54.00	-21.20	1.05 H	113	-6.63	39.43
7	7440.00	54.90 PK	74.00	-19.10	1.00 H	215	8.33	46.57
8	7440.00	24.80 AV	54.00	-29.20	1.00 H	215	-21.77	46.57
ANTENNA POLARITY & TEST DISTANCE: VERTICAL AT 3 M								
NO.	FREQ. (MHz)	EMISSION LEVEL (dBuV/m)	LIMIT (dBuV/m)	MARGIN (dB)	ANTENNA HEIGHT (m)	TABLE ANGLE (Degree)	RAW VALUE (dBuV)	CORRECTION FACTOR (dB/m)
1	*2480.00	99.50 PK			1.00 V	67	67.54	31.96
2	*2480.00	69.40 AV			1.00 V	67	37.44	31.96
3	2483.50	59.45 PK	74.00	-14.55	1.00 V	67	27.48	31.97
4	2483.50	29.35 AV	54.00	-24.65	1.00 V	67	-2.62	31.97
5	4960.00	59.80 PK	74.00	-14.20	1.08 V	292	20.37	39.43
6	4960.00	29.70 AV	54.00	-24.30	1.08 V	292	-9.73	39.43
7	7440.00	55.30 PK	74.00	-18.70	1.16 V	110	8.73	46.57
8	7440.00	25.20 AV	54.00	-28.80	1.16 V	110	-21.37	46.57

- REMARKS:**
- Emission level (dBuV/m) = Raw Value (dBuV) + Correction Factor (dB/m).
 - Correction Factor (dB/m) = Antenna Factor (dB/m) + Cable Factor (dB).
 - The other emission levels were very low against the limit.
 - Margin value = Emission level – Limit value.
 - * *: Fundamental frequency.
 - The DH5 packet was the worse case duty cycle for a transmit dwell time on a channel, based upon bluetooth theory the transmitter is on 0.625 * 5 per 296.25 ms per channel. Therefore, the duty cycle correlation factor be equal to: $20\log(3.125 / 100) = -30.1$ dB.
 - Average value = peak reading + $20\log(\text{duty cycle})$.



8DPSK MODULATION

EUT TEST CONDITION		MEASUREMENT DETAIL	
CHANNEL	Channel 0	FREQUENCY RANGE	1 ~ 25GHz
INPUT POWER (SYSTEM)	120Vac, 60 Hz	DETECTOR FUNCTION	Peak (PK) Average (AV)
ENVIRONMENTAL CONDITIONS	19deg. C, 71%RH 1023 hPa	TESTED BY	Rex Huang

ANTENNA POLARITY & TEST DISTANCE: HORIZONTAL AT 3 M								
NO.	FREQ. (MHz)	EMISSION LEVEL (dBuV/m)	LIMIT (dBuV/m)	MARGIN (dB)	ANTENNA HEIGHT (m)	TABLE ANGLE (Degree)	RAW VALUE (dBuV)	CORRECTION FACTOR (dB/m)
1	1602.00	53.6 PK	74.00	-20.4	1.00 H	270	25.25	28.35
2	1602.00	23.5 AV	54.00	-30.5	1.00 H	270	-4.85	28.35
3	2386.00	65.1 PK	74.00	-8.9	1.00 H	267	33.45	31.65
4	2386.00	35.0 AV	54.00	-19.0	1.00 H	267	3.35	31.65
5	*2402.00	109.7 PK			1.00 H	267	78.00	31.70
6	*2402.00	79.6 AV			1.00 H	267	47.90	31.70
7	4804.00	53.0 PK	74.00	-21.0	1.00 H	112	14.09	38.91
8	4804.00	22.9 AV	54.00	-31.1	1.00 H	112	-16.01	38.91
ANTENNA POLARITY & TEST DISTANCE: VERTICAL AT 3 M								
NO.	FREQ. (MHz)	EMISSION LEVEL (dBuV/m)	LIMIT (dBuV/m)	MARGIN (dB)	ANTENNA HEIGHT (m)	TABLE ANGLE (Degree)	RAW VALUE (dBuV)	CORRECTION FACTOR (dB/m)
1	1602.00	47.4 PK	74.00	-26.6	1.05 V	253	19.05	28.35
2	1602.00	17.3 AV	54.00	-36.7	1.05 V	253	-11.05	28.35
3	2386.00	60.2 PK	74.00	-13.8	1.00 V	60	28.54	31.65
4	2386.00	30.1 AV	54.00	-23.9	1.00 V	60	-1.56	31.65
5	*2402.00	103.4 PK			1.00 V	60	71.70	31.70
6	*2402.00	73.3 AV			1.00 V	60	41.60	31.70
7	4804.00	54.7 PK	74.00	-19.3	1.08 V	293	15.79	38.91
8	4804.00	24.6 AV	54.00	-29.4	1.08 V	293	-14.31	38.91

- REMARKS:**
1. Emission level (dBuV/m) = Raw Value (dBuV) + Correction Factor (dB/m).
 2. Correction Factor (dB/m) = Antenna Factor (dB/m) + Cable Factor (dB).
 3. The other emission levels were very low against the limit.
 4. Margin value = Emission level – Limit value.
 5. “ * “: Fundamental frequency.
 6. The DH5 packet was the worse case duty cycle for a transmit dwell time on a channel, based upon bluetooth theory the transmitter is on 0.625 * 5 per 296.25 ms per channel. Therefore, the duty cycle correlation factor be equal to: $20\log(3.125 / 100) = -30.1$ dB.
 7. Average value = peak reading + $20\log(\text{duty cycle})$.



EUT TEST CONDITION		MEASUREMENT DETAIL	
CHANNEL	Channel 39	FREQUENCY RANGE	1 ~ 25GHz
INPUT POWER (SYSTEM)	120Vac, 60 Hz	DETECTOR FUNCTION	Peak (PK) Average (AV)
ENVIRONMENTAL CONDITIONS	19deg. C, 71%RH 1023 hPa	TESTED BY	Rex Huang

ANTENNA POLARITY & TEST DISTANCE: HORIZONTAL AT 3 M

NO.	FREQ. (MHz)	EMISSION LEVEL (dBuV/m)	LIMIT (dBuV/m)	MARGIN (dB)	ANTENNA HEIGHT (m)	TABLE ANGLE (Degree)	RAW VALUE (dBuV)	CORRECTION FACTOR (dB/m)
1	*2441.00	107.3 PK			1.00 H	267	75.47	31.83
2	*2441.00	77.2 AV			1.00 H	267	45.37	31.83
3	4882.00	50.9 PK	74.00	-23.1	1.03 H	113	11.73	39.17
4	4882.00	20.8 AV	54.00	-33.2	1.03 H	113	-18.37	39.17
5	7323.00	54.7 PK	74.00	-19.3	1.00 H	216	8.07	46.63
6	7323.00	24.6 AV	54.00	-29.4	1.00 H	216	-22.03	46.63

ANTENNA POLARITY & TEST DISTANCE: VERTICAL AT 3 M

NO.	FREQ. (MHz)	EMISSION LEVEL (dBuV/m)	LIMIT (dBuV/m)	MARGIN (dB)	ANTENNA HEIGHT (m)	TABLE ANGLE (Degree)	RAW VALUE (dBuV)	CORRECTION FACTOR (dB/m)
1	*2441.00	100.4 PK			1.00 V	59	68.57	31.83
2	*2441.00	70.3 AV			1.00 V	59	38.47	31.83
3	4882.00	52.5 PK	74.00	-21.5	1.09 V	289	13.33	39.17
4	4882.00	22.4 AV	54.00	-31.6	1.09 V	289	-16.77	39.17
5	7323.00	54.9 PK	74.00	-19.1	1.17 V	127	8.27	46.63
6	7323.00	24.8 AV	54.00	-29.2	1.17 V	127	-21.83	46.63

- REMARKS:**
- Emission level (dBuV/m) = Raw Value (dBuV) + Correction Factor (dB/m).
 - Correction Factor (dB/m) = Antenna Factor (dB/m) + Cable Factor (dB).
 - The other emission levels were very low against the limit.
 - Margin value = Emission level – Limit value.
 - “ * “: Fundamental frequency.
 - The DH5 packet was the worse case duty cycle for a transmit dwell time on a channel, based upon bluetooth theory the transmitter is on 0.625 * 5 per 296.25 ms per channel. Therefore, the duty cycle correlation factor be equal to: $20\log(3.125 / 100) = -30.1$ dB.
 - Average value = peak reading + 20log(duty cycle).



A D T

EUT TEST CONDITION		MEASUREMENT DETAIL	
CHANNEL	Channel 78	FREQUENCY RANGE	1 ~ 25GHz
INPUT POWER (SYSTEM)	120Vac, 60 Hz	DETECTOR FUNCTION	Peak (PK) Average (AV)
ENVIRONMENTAL CONDITIONS	19deg. C, 71%RH 1023 hPa	TESTED BY	Rex Huang

ANTENNA POLARITY & TEST DISTANCE: HORIZONTAL AT 3 M

NO.	FREQ. (MHz)	EMISSION LEVEL (dBuV/m)	LIMIT (dBuV/m)	MARGIN (dB)	ANTENNA HEIGHT (m)	TABLE ANGLE (Degree)	RAW VALUE (dBuV)	CORRECTION FACTOR (dB/m)
1	*2480.00	106.7 PK			1.00 H	267	74.74	31.96
2	*2480.00	76.6 AV			1.00 H	267	44.64	31.96
3	2483.50	67.0 PK	74.00	-7.0	1.00 H	267	35.07	31.97
4	2483.50	36.9 AV	54.00	-17.1	1.00 H	267	4.97	31.97
5	4960.00	49.4 PK	74.00	-24.6	1.10 H	113	9.97	39.43
6	4960.00	19.3 AV	54.00	-34.7	1.10 H	113	-20.13	39.43
7	7440.00	54.8 PK	74.00	-19.2	1.00 H	213	8.23	46.57
8	7440.00	24.7 AV	54.00	-29.3	1.00 H	213	-21.87	46.57

ANTENNA POLARITY & TEST DISTANCE: VERTICAL AT 3 M

NO.	FREQ. (MHz)	EMISSION LEVEL (dBuV/m)	LIMIT (dBuV/m)	MARGIN (dB)	ANTENNA HEIGHT (m)	TABLE ANGLE (Degree)	RAW VALUE (dBuV)	CORRECTION FACTOR (dB/m)
1	*2480.00	99.0 PK			1.00 V	68	67.04	31.96
2	*2480.00	68.9 AV			1.00 V	68	36.94	31.96
3	2483.50	61.3 PK	74.00	-12.7	1.00 V	68	29.36	31.97
4	2483.50	31.2 AV	54.00	-22.8	1.00 V	68	-0.74	31.97
5	4960.00	52.7 PK	74.00	-21.3	1.08 V	293	13.27	39.43
6	4960.00	22.6 AV	54.00	-31.4	1.08 V	293	-16.83	39.43
7	7440.00	54.6 PK	74.00	-19.4	1.14 V	108	8.03	46.57
8	7440.00	24.5 AV	54.00	-29.5	1.14 V	108	-22.07	46.57

- REMARKS:**
1. Emission level (dBuV/m) = Raw Value (dBuV) + Correction Factor (dB/m).
 2. Correction Factor (dB/m) = Antenna Factor (dB/m) + Cable Factor (dB).
 3. The other emission levels were very low against the limit.
 4. Margin value = Emission level – Limit value.
 5. “ * “: Fundamental frequency.
 6. The DH5 packet was the worse case duty cycle for a transmit dwell time on a channel, based upon bluetooth theory the transmitter is on 0.625 * 5 per 296.25 ms per channel. Therefore, the duty cycle correlation factor be equal to: $20\log(3.125 / 100) = -30.1$ dB.
 7. Average value = peak reading + $20\log(\text{duty cycle})$.



4.8 CONDUCTED OUT-BAND EMISSION MEASUREMENT

4.8.1 LIMITS OF CONDUCTED OUT-BAND EMISSION MEASUREMENT

Below -20dB of the highest emission level of operating band (in 100KHz RBW).

4.8.2 TEST INSTRUMENTS

DESCRIPTION & MANUFACTURER	MODEL NO.	SERIAL NO.	CALIBRATED DATE	CALIBRATED UNTIL
R&S SPECTRUM ANALYZER	FSP40	100037	Aug. 09, 2009	Aug. 08, 2010

NOTE:

- 1.The calibration interval of the above test instruments is 12 months and the calibrations are traceable to NML/ROC and NIST/USA.

4.8.3 TEST PROCEDURE

The transmitter output was connected to the spectrum analyzer via a low lose cable. Set RBW a of spectrum analyzer to 100 kHz and VBW of spectrum analyzer to 300 kHz with suitable frequency span including 100 MHz bandwidth from band edge. The band edges was measured and recorded.

4.8.4 DEVIATION FROM TEST STANDARD

No deviation

4.8.5 EUT OPERATING CONDITION

The software provided by client enabled the EUT to transmit and receive data at lowest, middle and highest channel frequencies individually.

4.8.6 TEST RESULTS

Emissions radiated outside of the specified frequency bands, please refer pages from 70 to 75 for met the requirement of the general radiated emission limits in § 15.209.

For GFSK MODULATION TYPE:

CH0

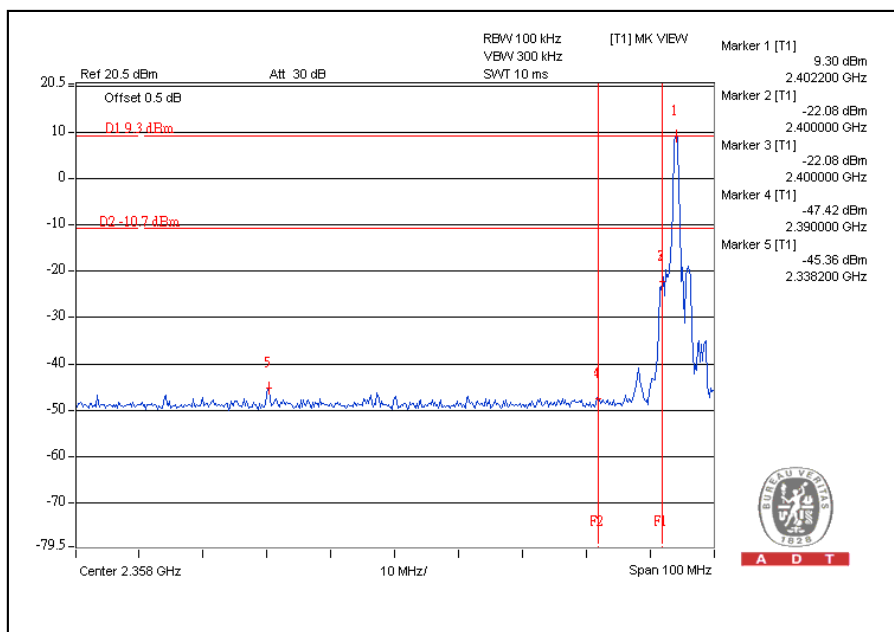

CH78

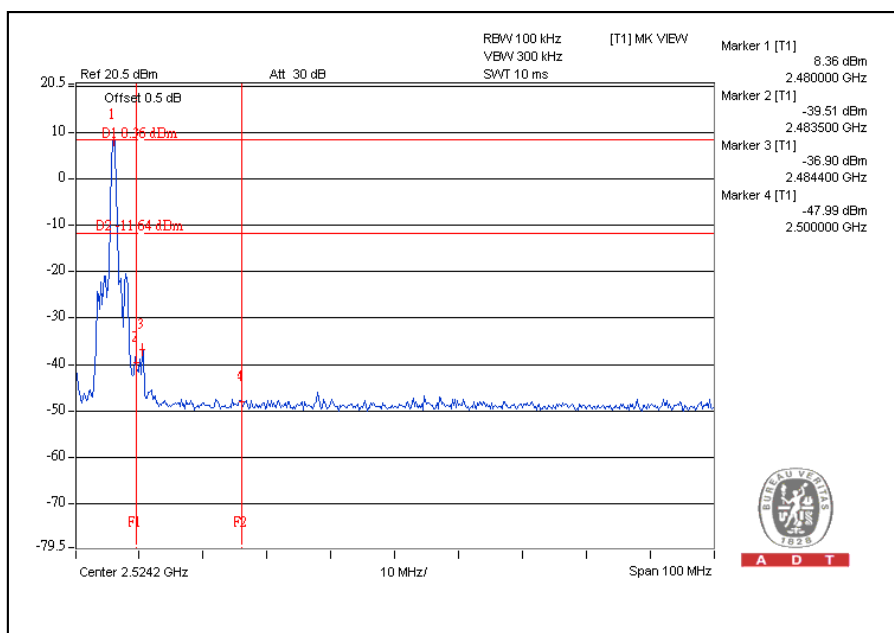



A D T

CH0

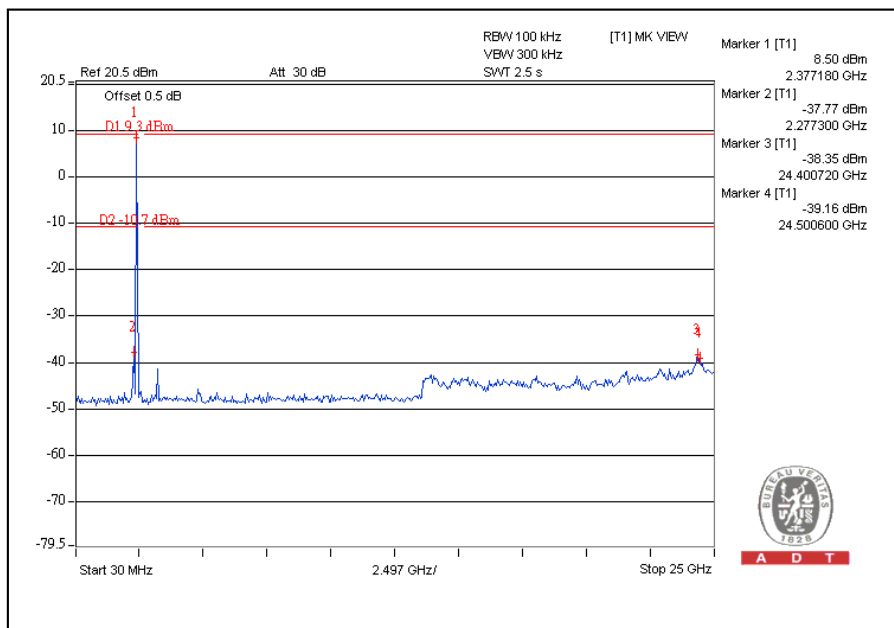

CH78

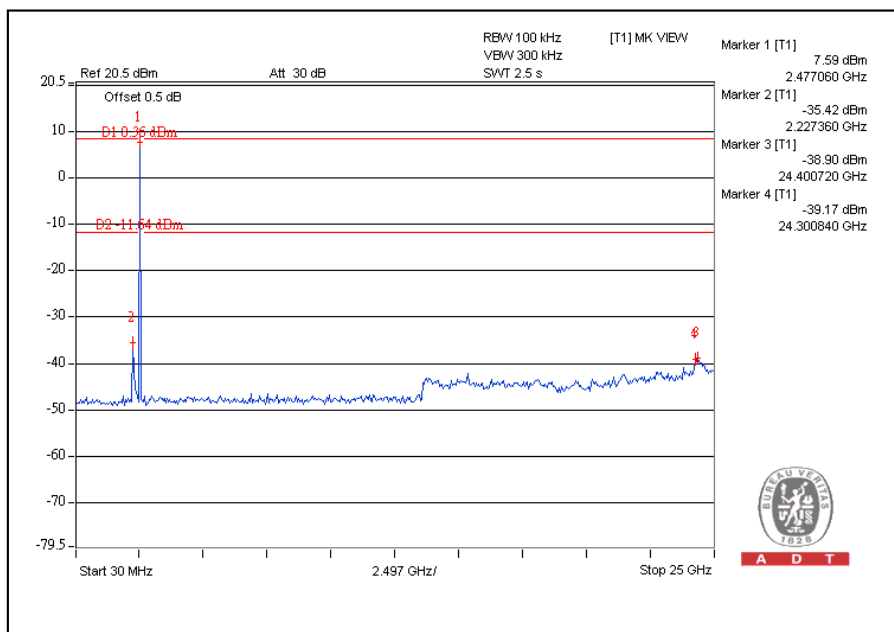



A D T

FOR $\pi/4$ -DQPSK MODULATION TYPE:

CH0

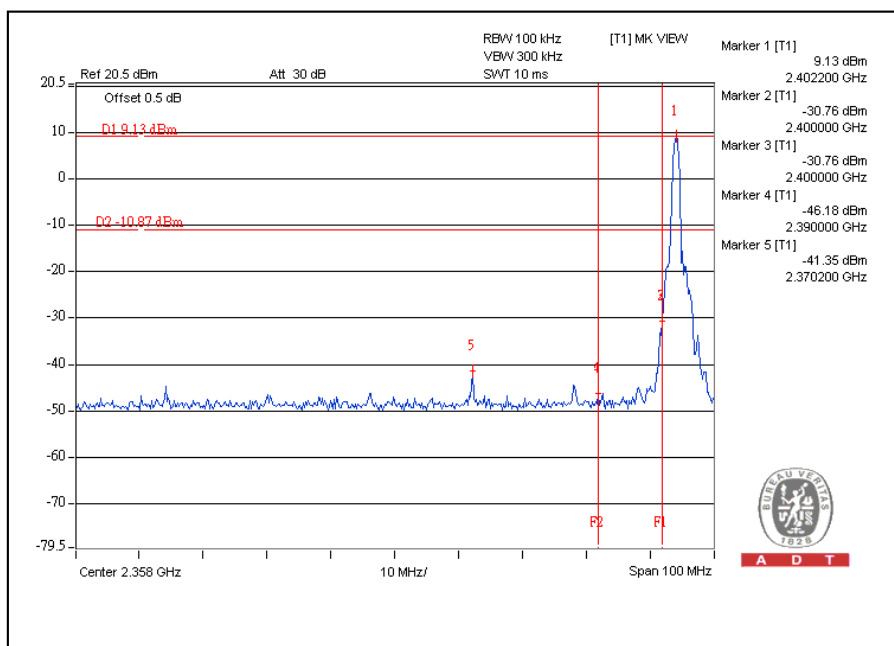

CH78

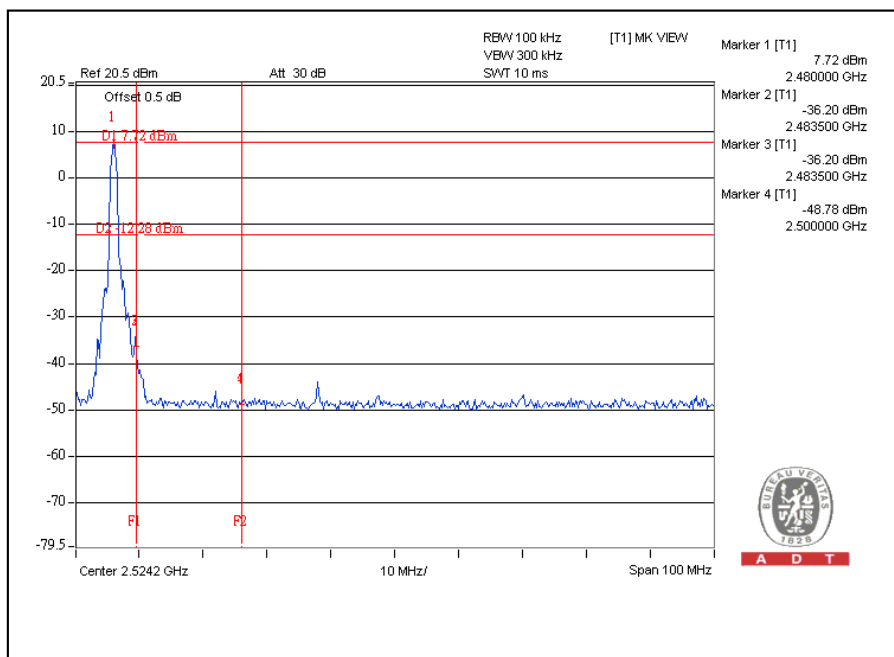



A D T

CH0

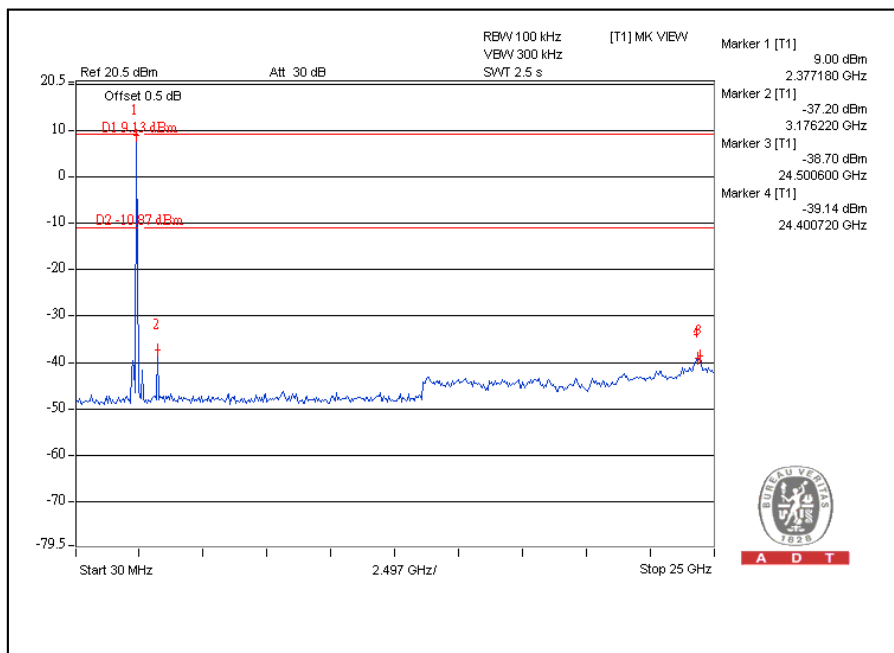

A D T

CH78

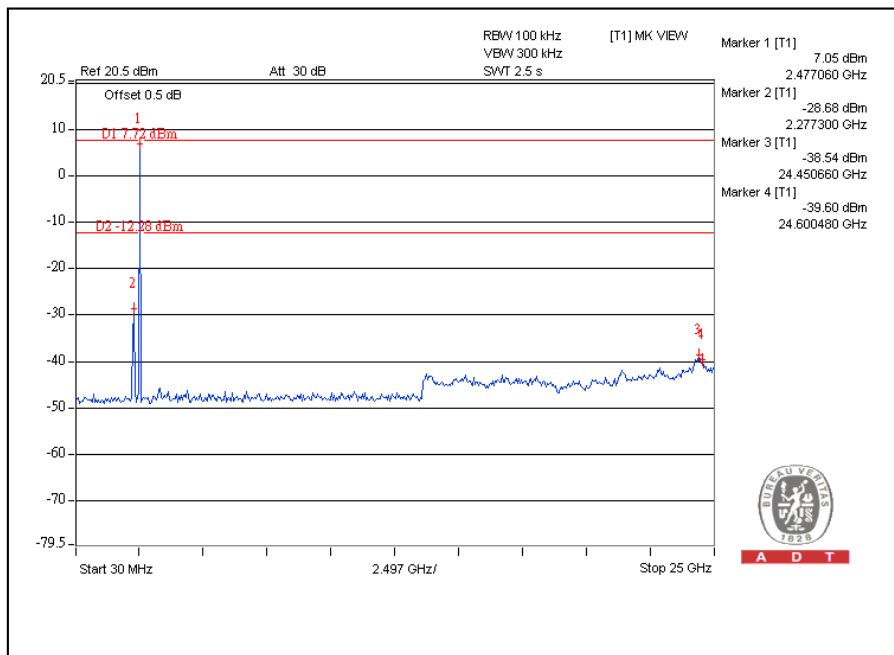

A D T



A D T

FOR 8DPSK MODULATION TYPE:

CH0

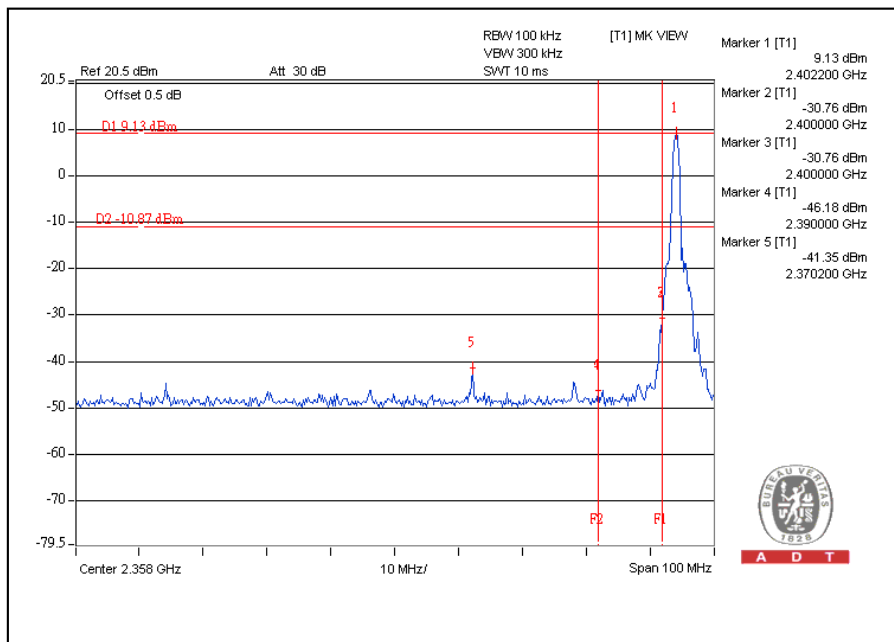

CH78

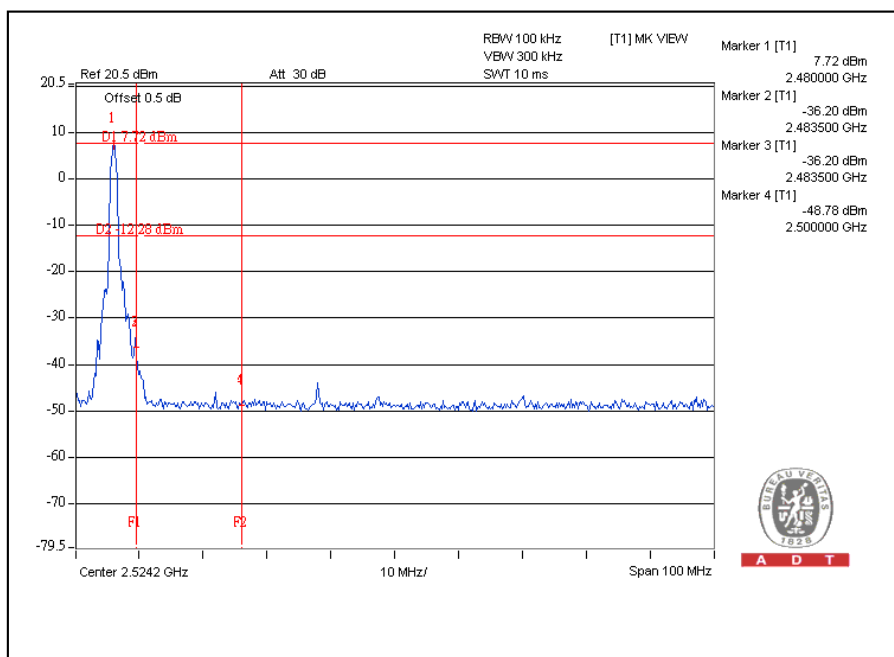



A D T

CH0

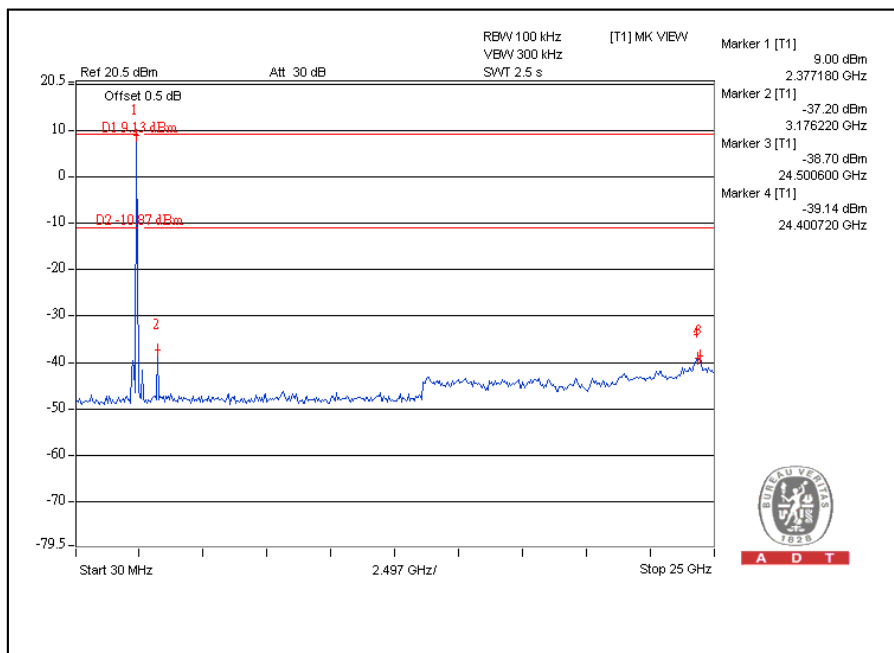

CH78

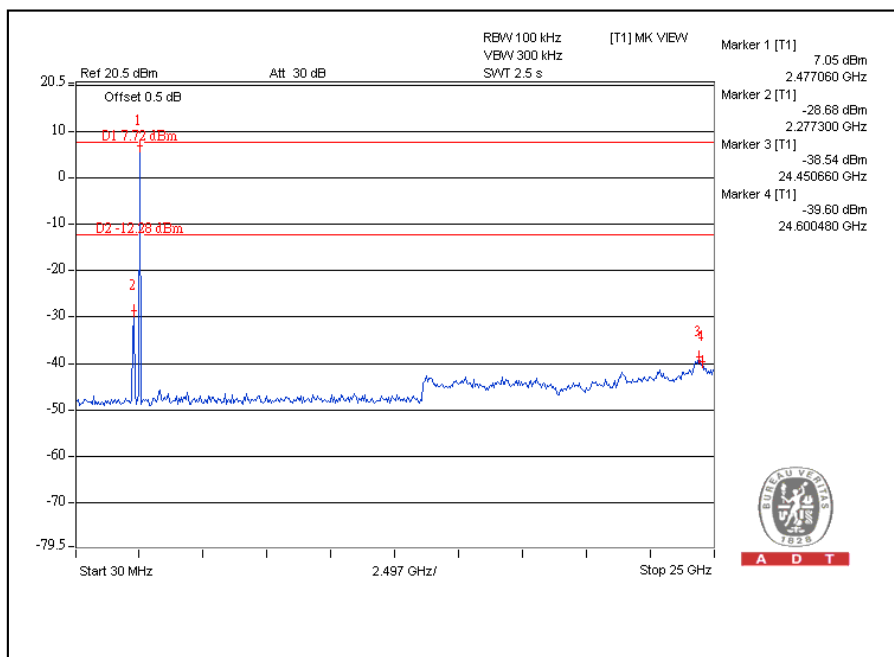



A D T

5. INFORMATION ON THE TESTING LABORATORIES

We, Bureau Veritas Consumer Products Services (H.K.) Ltd., Taoyuan Branch, were founded in 1988 to provide our best service in EMC, Radio, Telecom and Safety consultation. Our laboratories are accredited and approved according to ISO/IEC 17025:

Copies of accreditation certificates of our laboratories obtained from approval agencies can be downloaded from our web site: www.adt.com.tw/index.5/phtml.

If you have any comments, please feel free to contact us at the following:

Linko EMC/RF Lab:

Tel: 886-2-26052180

Fax: 886-2-26052943

Hsin Chu EMC/RF Lab:

Tel: 886-3-5935343

Fax: 886-3-5935342

Hwa Ya EMC/RF/Safety/Telecom Lab:

Tel: 886-3-3183232

Fax: 886-3-3185050

Email: service@adt.com.tw

Web Site: www.adt.com.tw

The address and road map of all our labs can be found in our web site also.



A D T

6. APPENDIX - A MODIFICATIONS RECORDERS FOR ENGINEERING CHANGES TO THE EUT BY THE LAB

No any modifications are made to the EUT by the lab during the test.

--- END ---