



# CTC Laboratories, Inc.

Room 101 Building B, No. 7, Lanqing 1st Road, Luhua Community, Guanhu Subdistrict, Longhua District, Shenzhen, Guangdong, China  
Tel: +86-755-27521059 Fax: +86-755-27521011 <http://www.sz-ctc.org.cn>

## TEST REPORT

**Report No.** .....: **CTC2024198501**

**FCC ID**.....: **PADWF149**

**IC**.....: **10563A-WF149**

**FCC Applicant/Manufacturer**..: **Wahoo Fitness LLC**  
Address.....: 90 W. Wieuca Road #110, Atlanta, GA 30342, United States

**IC Applicant/Manufacturer**.....: **Wahoo Fitness**  
Address.....: 90 W. Wieuca Road #110, Atlanta, GA 30342, United States

**Product Name**.....: **Bike Computer**

Trade Mark.....: WAHOO FITNESS

Model/Type reference.....: WF149

Listed Model(s) .....: /

**Standard**.....: **FCC CFR Title 47 Part 15 Subpart C Section 15.247  
RSS-247 Issue 3**

Date of receipt of test sample...: Aug. 14, 2024

Date of testing.....: Aug. 14, 2024 ~ Sept. 9, 2024

Date of issue.....: Sept. 10, 2024

**Result**.....: **PASS**

Compiled by:

(Printed name+signature) Jim Jiang

Supervised by:

(Printed name+signature) Eric Zhang

Approved by:

(Printed name+signature) Totti Zhao

This test report may be duplicated completely for legal use with the approval of the applicant. It should not be reproduced except in full, without the written approval of our laboratory. The client should not use it to claim product endorsement by CTC. The test results in the report only apply to the tested sample. The test report shall be invalid without all the signatures of testing engineers, reviewer and approver. Any objections must be raised to CTC within 15 days since the date when the report is received. It will not be taken into consideration beyond this limit. The test report merely correspond to the test sample.



Table of Contents

Page

**1. TEST SUMMARY ..... 3**

1.1. TEST STANDARDS ..... 3

1.2. REPORT VERSION ..... 3

1.3. TEST DESCRIPTION ..... 3

1.4. TEST FACILITY ..... 4

1.5. MEASUREMENT UNCERTAINTY ..... 4

1.6. ENVIRONMENTAL CONDITIONS ..... 5

**2. GENERAL INFORMATION ..... 6**

2.1. CLIENT INFORMATION ..... 6

2.2. GENERAL DESCRIPTION OF EUT ..... 6

2.3. ACCESSORY EQUIPMENT INFORMATION ..... 7

2.4. OPERATION STATE ..... 8

2.5. MEASUREMENT INSTRUMENTS LIST ..... 9

**3. TEST ITEM AND RESULTS ..... 10**

3.1. CONDUCTED EMISSION ..... 10

3.2. RADIATED EMISSION ..... 13

3.3. BAND EDGE EMISSIONS (RADIATED) ..... 20

3.4. BAND EDGE AND SPURIOUS EMISSIONS (CONDUCTED) ..... 25

3.5. BANDWIDTH ..... 31

3.6. PEAK OUTPUT POWER ..... 34

3.7. POWER SPECTRAL DENSITY ..... 35

3.8. DUTY CYCLE ..... 37

3.9. ANTENNA REQUIREMENT ..... 39



# 1. TEST SUMMARY

## 1.1. Test Standards

The tests were performed according to following standards:

[FCC Rules Part 15.247](#): Operation within the bands of 902-928MHz, 2400-2483.5MHz, and 5725-5850MHz.

[RSS-247 Issue 3](#): Standard Specifications for Frequency Hopping Systems (FHSs) and Digital Transmission Systems (DTSS) Operating in the Bands 902-928MHz, 2400-2483.5MHz and 5725-5850MHz.

[RSS-Gen Issue 5](#): General Requirements for Compliance of Radio Apparatus.

[ANSI C63.10-2013](#): American National Standard for Testing Unlicensed Wireless Devices.

## 1.2. Report Version

| Revised No. | Report No.    | Date of issue  | Description |
|-------------|---------------|----------------|-------------|
| 01          | CTC2024198501 | Sept. 10, 2024 | Original    |
|             |               |                |             |
|             |               |                |             |

## 1.3. Test Description

| FCC Part 15 Subpart C (15.247) / RSS-247 Issue 3 |                         |                         |        |               |
|--|-------------------------|-------------------------|--------|---------------|
| Test Item  | Standard Section        |                         | Result | Test Engineer |
|  | FCC                     | IC                      |        |               |
| Antenna Requirement                              | 15.203                  | /                       | Pass   | Jim Jiang     |
| Conducted Emission                               | 15.207                  | RSS-Gen 8.8             | N/A    | N/A           |
| Conducted Band Edge and Spurious Emissions       | 15.247(d)               | RSS-247 5.5             | Pass   | Jim Jiang     |
| Radiated Band Edge and Spurious Emissions        | 15.205&15.209&15.247(d) | RSS-247 5.5             | Pass   | Jim Jiang     |
| 6dB Bandwidth                                    | 15.247(a)(2)            | RSS-247 5.2 (a)         | Pass   | Jim Jiang     |
| Conducted Max Output Power                       | 15.247(b)(3)            | RSS-247 5.4 (d)         | Pass   | Jim Jiang     |
| Power Spectral Density                           | 15.247(e)               | RSS-247 5.2 (b)         | Pass   | Jim Jiang     |
| Transmitter Radiated Spurious                    | 15.209&15.247(d)        | RSS-247 5.5&RSS-Gen 8.9 | Pass   | Jim Jiang     |

Note: "N/A" is not applicable.

The measurement uncertainty is not included in the test result.



## 1.4. Test Facility

### CTC Laboratories, Inc.

Add: Room 101 Building B, No. 7, Lanqing 1st Road, Luhuhu Community, Guanhu Subdistrict, Longhua District, Shenzhen, Guangdong, China

### Laboratory accreditation

The test facility is recognized, certified, or accredited by the following organizations:

#### A2LA-Lab Cert. No.: 4340.01

CTC Laboratories, Inc. EMC Laboratory has been accredited by A2LA for technical competence in the field of electrical testing, and proved to be in compliance with ISO/IEC 17025:2017 General Requirements for the Competence of Testing and Calibration Laboratories and any additional program requirements in the identified field of testing.

#### Industry Canada (Registration No.: 9783A, CAB Identifier: CN0029)

CTC Laboratories, Inc. EMC Laboratory has been registered by Certification and Engineer Bureau of Industry Canada for the performance of with Registration NO.: 9783A on Jan, 2016.

#### FCC (Registration No.: 951311, Designation Number CN1208)

CTC Laboratories, Inc. EMC Laboratory has been registered and fully described in a report filed with the (FCC) Federal Communications Commission. The acceptance letter from the FCC is maintained in our files. Registration 951311, Aug 26, 2017.

## 1.5. Measurement Uncertainty

The data and results referenced in this document are true and accurate. The reader is cautioned that there may be errors within the calibration limits of the equipment and facilities. The measurement uncertainty was calculated for all measurements listed in this test report acc. to TR-100028-01 "Electromagnetic compatibility and Radio spectrum Matters (ERM); Uncertainties in the measurement of mobile radio equipment characteristics; Part 1" and TR-100028-02 "Electromagnetic compatibility and Radio spectrum Matters (ERM); Uncertainties in the measurement of mobile radio equipment characteristics; Part 2" and is documented in the CTC Laboratories, Inc. quality system acc. to DIN EN ISO/IEC 17025. Furthermore, component and process variability of devices similar to that tested may result in additional deviation. The manufacturer has the sole responsibility of continued compliance of the device.

Below is the best measurement capability for CTC Laboratories, Inc.



| Test Items                                      | Measurement Uncertainty                                 | Notes |
|---|---|-------|
| DTS Bandwidth                                   | $\pm 0.0196\%$  | (1)   |
| Maximum Conducted Output Power                  | $\pm 0.686$ dB  | (1)   |
| Maximum Power Spectral Density Level            | $\pm 0.743$ dB  | (1)   |
| Band-edge Compliance                            | $\pm 1.328$ dB  | (1)   |
| Unwanted Emissions In Non-restricted Freq Bands | 9kHz-1GHz: $\pm 0.746$ dB<br>1GHz-26GHz: $\pm 1.328$ dB | (1)   |
| Conducted Emissions 9kHz~30MHz                  | $\pm 3.08$ dB   | (1)   |
| Radiated Emissions 30~1000MHz                   | $\pm 4.51$ dB   | (1)   |
| Radiated Emissions 1~18GHz                      | $\pm 5.84$ dB   | (1)   |
| Radiated Emissions 18~40GHz                     | $\pm 6.12$ dB   | (1)   |

Note (1): This uncertainty represents an expanded uncertainty expressed at approximately the 95% confidence level using a coverage factor of  $k=2$ .

## 1.6. Environmental Conditions

During the measurement the environmental conditions were within the listed ranges:

|                    |                |
|--------------------|----------------|
| Temperature:       | 15 °C to 35 °C |
| Relative Humidity: | 20 % to 75 %   |
| Air Pressure:      | 101 kPa        |



## 2. GENERAL INFORMATION

### 2.1. Client Information

|                              |  |
|------------------------------|--|
| FCC Applicant/ Manufacturer: | Wahoo Fitness LLC  |
| Address:                     | 90 W. Wieuca Road #110, Atlanta, GA 30342, United States |
| IC Applicant/ Manufacturer:  | Wahoo Fitness  |
| Address:                     | 90 W. Wieuca Road #110, Atlanta, GA 30342, United States |

### 2.2. General Description of EUT

|                       |  |
|-----------------------|--|
| Product Name:         | Bike Computer  |
| Trade Mark:           | WAHOO FITNESS  |
| Model/Type reference: | WF149  |
| Listed Model(s):      | /  |
| Model Difference:     | /  |
| Power supply:         | 5Vdc from USB Cable, 3.85Vdc from 4350mAh Li-ion Battery |
| Sample ID:            | CTC240528-006-S001                                       |
| Hardware version:     | DVT1   |
| Software version:     | ACE-userdebug-(0029)                                     |
| <b>BT 5.0/ BLE</b>    |  |
| Modulation:           | GFSK   |
| Data rate:            | 1Mbps  |
| Operation frequency:  | 2402MHz~2480MHz  |
| Channel number:       | 40   |
| Channel separation:   | 2MHz   |
| Antenna type:         | Chip Antenna   |
| Antenna gain:         | 0.5dBi   |



## 2.3. Accessory Equipment Information

| Equipment Information     |               |              |              |
|---------------------------|---------------|--------------|--------------|
| Name                      | Model         | S/N          | Manufacturer |
| Adapter                   | A2167         | /            | Apple        |
| Cable Information         |               |              |              |
| Name                      | Shielded Type | Ferrite Core | Length       |
| USB Cable                 | Unshielded    | NO           | 100cm        |
| Test Software Information |               |              |              |
| Name                      | Version       | /            | /            |
| WahooSerial               | /             | /            | /            |



### 2.4. Operation State

Operation Frequency List: The EUT has been tested under typical operating condition. The Applicant provides communication tools software to control the EUT for staying in continuous transmitting and receiving mode for testing. BT BLE, 40 channels are provided to the EUT. Channels 00/19/39 were selected for testing. Operation Frequency List:

| Channel   | Frequency (MHz) |
|-----------|-----------------|
| <b>00</b> | <b>2402</b>     |
| 01        | 2404            |
| :         | :               |
| 18        | 2438            |
| <b>19</b> | <b>2440</b>     |
| 20        | 2442            |
| :         | :               |
| 38        | 2478            |
| <b>39</b> | <b>2480</b>     |

Note: The display in grey were the channel selected for testing.

#### Test mode

|  |
|--|
| For RF test items:   |
| The engineering test program was provided and enabled to make EUT continuous transmit.   |
| For AC power line conducted emissions:   |
| The EUT was set to connect with the Bluetooth instrument under large package sizes transmission.   |
| For Radiated spurious emissions test item:   |
| The engineering test program was provided and enabled to make EUT continuous transmit. The EUT in each of three orthogonal axis emissions had been tested, but only the worst case (X axis) data recorded in the report. |





## 2.5. Measurement Instruments List

| RF Test System |                                       |              |           |            |                  |
|----------------|---------------------------------------|--------------|-----------|------------|------------------|
| Item           | Test Equipment                        | Manufacturer | Model No. | Serial No. | Calibrated Until |
| 1              | Spectrum Analyzer                     | R&S          | FSV40-N   | 101331     | Mar. 21, 2025    |
| 2              | Spectrum Analyzer                     | R&S          | FSU26     | 100105     | Dec. 12, 2024    |
| 3              | MXA Signal Analyzer                   | Keysight     | N9020A    | MY46471737 | Dec. 12, 2024    |
| 4              | MXG Vector Signal Generator           | Agilent      | N5182A    | MY47420864 | Dec. 12, 2024    |
| 5              | PSG Analog Signal Generator           | Agilent      | E8257D    | MY46521908 | Dec. 12, 2024    |
| 6              | EXG Analog Signal Generator           | Keysight     | N5173B    | MY59100842 | Dec. 12, 2024    |
| 7              | MXG Vector Signal Generator           | Keysight     | N5182B    | MY59100212 | Dec. 12, 2024    |
| 8              | USB Wideband Power Sensor             | Keysight     | U2021XA   | MY55130004 | Mar. 21, 2025    |
| 9              | USB Wideband Power Sensor             | Keysight     | U2021XA   | MY55130006 | Mar. 21, 2025    |
| 10             | Wideband Radio Communication Tester   | R&S          | CMW500    | 102414     | Dec. 12, 2024    |
| 11             | High and low temperature test chamber | ESPEC        | MT3035    | /          | Mar. 21, 2025    |

| Radiated Emission (3m chamber 3) |                              |              |            |            |                  |
|----------------------------------|------------------------------|--------------|------------|------------|------------------|
| Item                             | Test Equipment               | Manufacturer | Model No.  | Serial No. | Calibrated Until |
| 1                                | Trilog-Broadband Antenna     | Schwarzbeck  | VULB 9163  | 01026      | Dec. 18, 2024    |
| 2                                | Horn Antenna                 | Schwarzbeck  | BBHA 9120D | 9120D-647  | Dec. 01, 2024    |
| 3                                | Test Receiver                | Keysight     | N9038A     | MY56400071 | Dec. 12, 2024    |
| 4                                | Broadband Amplifier          | SCHWARZBECK  | BBV9743B   | 259        | Dec. 12, 2024    |
| 5                                | Mirowave Broadband Amplifier | SCHWARZBECK  | BBV9718C   | 111        | Dec. 12, 2024    |
| 6                                | 3m chamber 3                 | YIHENG       | EE106      | /          | Aug. 28, 2026    |
| 7                                | Test Software                | FARA         | EZ-EMC     | FA-03A2    | /                |

| Conducted Emission |                   |              |           |                |                  |
|--------------------|-------------------|--------------|-----------|----------------|------------------|
| Item               | Test Equipment    | Manufacturer | Model No. | Serial No.     | Calibrated Until |
| 1                  | LISN              | R&S          | ENV216    | 101112         | Dec. 12, 2024    |
| 2                  | LISN              | R&S          | ENV216    | 101113         | Dec. 12, 2024    |
| 3                  | EMI Test Receiver | R&S          | ESCS30    | 100353         | Dec. 12, 2024    |
| 4                  | ISN CAT6          | Schwarzbeck  | NTFM 8158 | CAT6-8158-0046 | Dec. 12, 2024    |
| 5                  | ISN CAT5          | Schwarzbeck  | NTFM 8158 | CAT5-8158-0046 | Dec. 12, 2024    |
| 6                  | Test Software     | R&S          | EMC32     | 6.10.10        | /                |

Note: 1. The Cal. Interval was one year.

2. The Cal. Interval was three year of the chamber

3. The cable loss has calculated in test result which connection between each test instruments.

CTC Laboratories, Inc.

Room 101 Building B, No. 7, Lanqing 1st Road, Luhua Community, Guanhu Subdistrict, Longhua District, Shenzhen, Guangdong, China  
Tel.: (86)755-27521059 Fax: (86)755-27521011 Http://www.sz-ctc.org.cn



For anti-fake verification, please visit the official website of Certification and Accreditation Administration of the People's Republic of China : [yz.cnca.cn](http://yz.cnca.cn)

### 3. TEST ITEM AND RESULTS

#### 3.1. Conducted Emission

**Limit**

FCC CFR Title 47 Part 15 Subpart C Section 15.207/ RSS - Gen 8.8

| Frequency range (MHz) | Limit (dBuV) |           |
|-----------------------|--------------|-----------|
|                       | Quasi-peak   | Average   |
| 0.15-0.5              | 66 to 56*    | 56 to 46* |
| 0.5-5                 | 56           | 46        |
| 5-30                  | 60           | 50        |

\* Decreases with the logarithm of the frequency.

**Test Configuration**

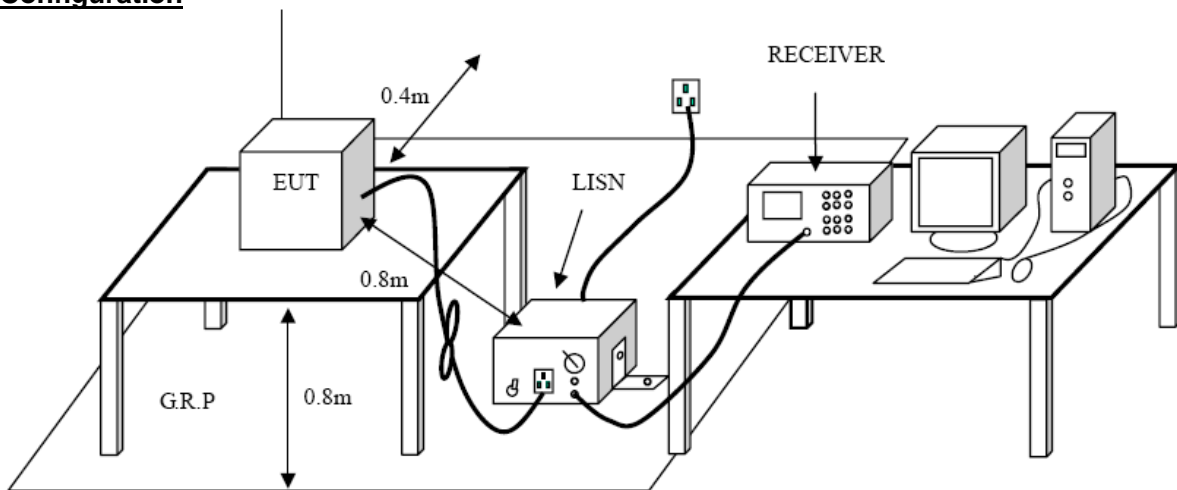

**Test Procedure**

1. The EUT was setup according to ANSI C63.10:2013 requirements.
2. The EUT was placed on a platform of nominal size, 1 m by 1.5 m, raised 10 cm above the conducting ground plane. The vertical conducting plane was located 40 cm to the rear of the EUT. All other surfaces of EUT were at least 10 cm from any other grounded conducting surface.
3. The EUT and simulators are connected to the main power through a line impedances stabilization network (LISN). The LISN provides a 50ohm /50uH coupling impedance for the measuring equipment. The peripheral devices are also connected to the main power through a LISN. (Please refer to the block diagram of the test setup and photographs)
4. Each current-carrying conductor of the EUT power cord, except the ground (safety) conductor, was individually connected through a LISN to the input power source.
5. The excess length of the power cord between the EUT and the LISN receptacle were folded back and forth at the center of the lead to form a bundle not exceeding 40 cm in length.
6. Conducted Emissions were investigated over the frequency range from 0.15MHz to 30MHz using a receiver bandwidth of 9 kHz.
7. During the above scans, the emissions were maximized by cable manipulation.



**Test Mode**

Please refer to the clause 2.4.

**Test Results**

|                      |                              |
|----------------------|------------------------------|
| <b>Test Voltage:</b> | AC 120V/60Hz                 |
| <b>Terminal:</b>     | Line                         |
| <b>Remark:</b>       | Only worse case is reported. |

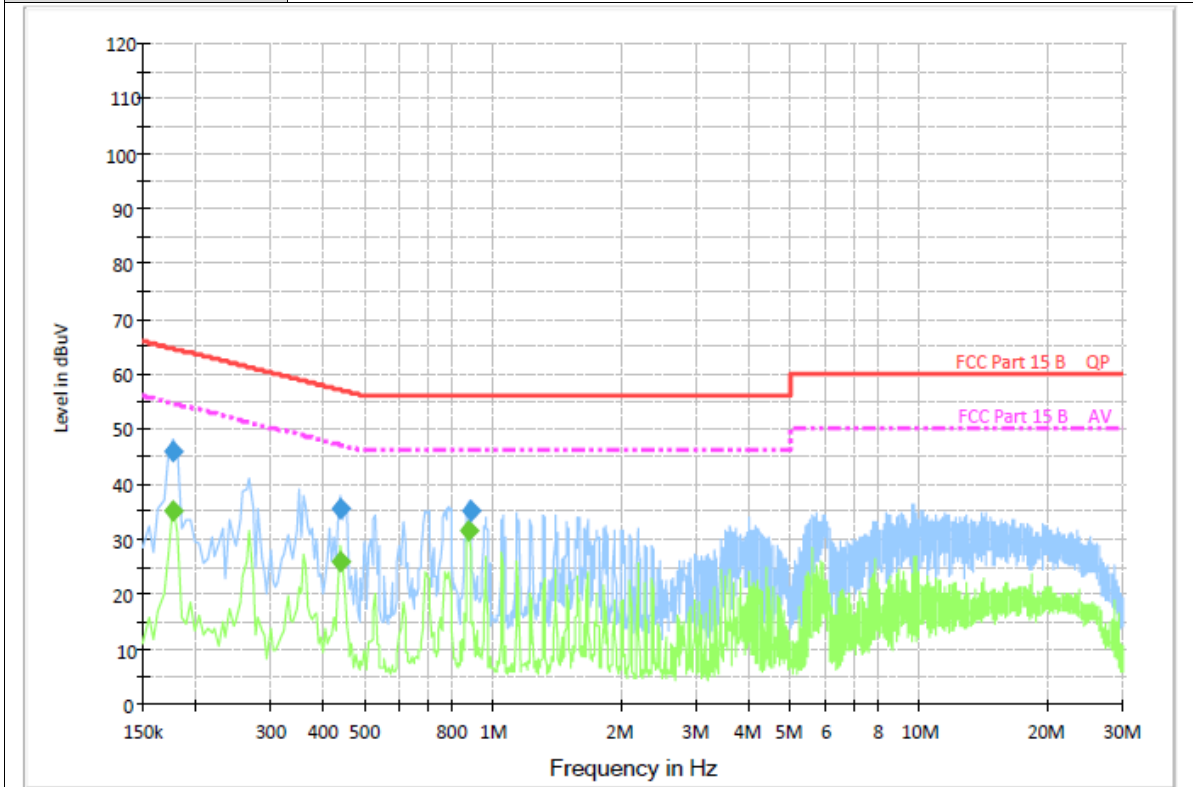

**Final Measurement Detector 1**

| Frequency (MHz) | QuasiPeak (dB μV) | Meas. Time (ms) | Bandwidth (kHz) | Filter | Line | Corr. (dB) | Margin (dB) | Limit (dB μV) | Comment |
|-----------------|-------------------|-----------------|-----------------|--------|------|------------|-------------|---------------|---------|
| 0.177000        | 46.2              | 1000.00         | 9.000           | On     | L1   | 9.5        | 18.4        | 64.6          |         |
| 0.438000        | 35.5              | 1000.00         | 9.000           | On     | L1   | 9.5        | 21.6        | 57.1          |         |
| 0.879000        | 35.1              | 1000.00         | 9.000           | On     | L1   | 9.5        | 20.9        | 56.0          |         |

**Final Measurement Detector 2**

| Frequency (MHz) | Average (dB μV) | Meas. Time (ms) | Bandwidth (kHz) | Filter | Line | Corr. (dB) | Margin (dB) | Limit (dB μV) | Comment |
|-----------------|-----------------|-----------------|-----------------|--------|------|------------|-------------|---------------|---------|
| 0.177000        | 35.1            | 1000.00         | 9.000           | On     | L1   | 9.5        | 19.5        | 54.6          |         |
| 0.438000        | 25.8            | 1000.00         | 9.000           | On     | L1   | 9.5        | 21.3        | 47.1          |         |
| 0.870000        | 31.5            | 1000.00         | 9.000           | On     | L1   | 9.5        | 14.5        | 46.0          |         |

Emission Level = Read Level + Correct Factor



|                      |                              |
|----------------------|------------------------------|
| <b>Test Voltage:</b> | AC 120V/60Hz                 |
| <b>Terminal:</b>     | Neutral                      |
| <b>Remark:</b>       | Only worse case is reported. |

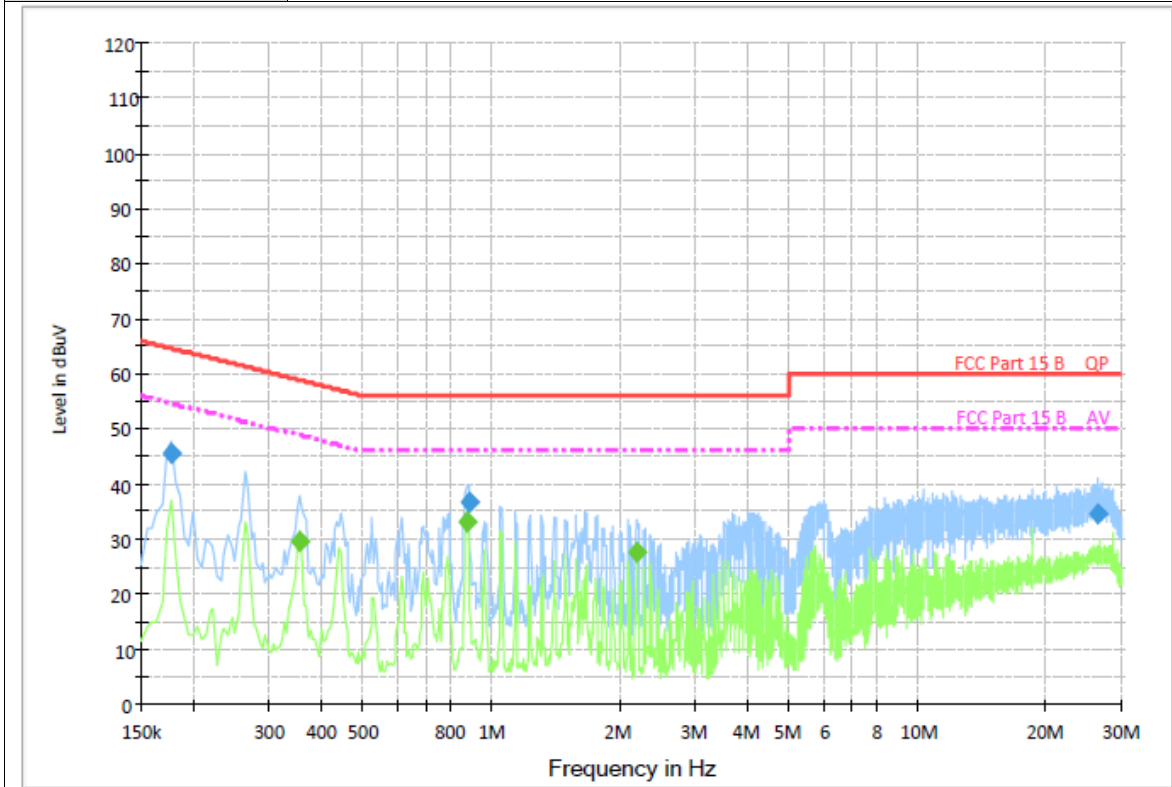

**Final Measurement Detector 1**

| Frequency (MHz) | QuasiPeak (dB μV) | Meas. Time (ms) | Bandwidth (kHz) | Filter | Line | Corr. (dB) | Margin (dB) | Limit (dB μV) | Comment |
|-----------------|-------------------|-----------------|-----------------|--------|------|------------|-------------|---------------|---------|
| 0.177000        | 45.7              | 1000.00         | 9.000           | On     | N    | 9.5        | 18.9        | 64.6          |         |
| 0.883500        | 36.3              | 1000.00         | 9.000           | On     | N    | 9.4        | 19.7        | 56.0          |         |
| 26.403000       | 34.5              | 1000.00         | 9.000           | On     | N    | 9.5        | 25.5        | 60.0          |         |

**Final Measurement Detector 2**

| Frequency (MHz) | Average (dB μV) | Meas. Time (ms) | Bandwidth (kHz) | Filter | Line | Corr. (dB) | Margin (dB) | Limit (dB μV) | Comment |
|-----------------|-----------------|-----------------|-----------------|--------|------|------------|-------------|---------------|---------|
| 0.352500        | 29.7            | 1000.00         | 9.000           | On     | N    | 9.4        | 19.2        | 48.9          |         |
| 0.874500        | 33.2            | 1000.00         | 9.000           | On     | N    | 9.4        | 12.8        | 46.0          |         |
| 2.179500        | 27.6            | 1000.00         | 9.000           | On     | N    | 9.4        | 18.4        | 46.0          |         |

Emission Level = Read Level + Correct Factor

### 3.2. Radiated Emission

#### Limit

FCC CFR Title 47 Part 15 Subpart C Section 15.209/ RSS – Gen 8.9

| Frequency         | Limit (dBuV/m @3m) | Value      |
|-------------------|--------------------|------------|
| 30 MHz ~ 88 MHz   | 40.00              | Quasi-peak |
| 88 MHz ~ 216 MHz  | 43.50              | Quasi-peak |
| 216 MHz ~ 960 MHz | 46.00              | Quasi-peak |
| 960 MHz ~ 1 GHz   | 54.00              | Quasi-peak |
| Above 1 GHz       | 54.00              | Average    |
|                   | 74.00              | Peak       |

#### Note:

- (1) The tighter limit applies at the band edges.
- (2) Emission Level (dBuV/m)=20log Emission Level (uV/m).

#### Test Configuration

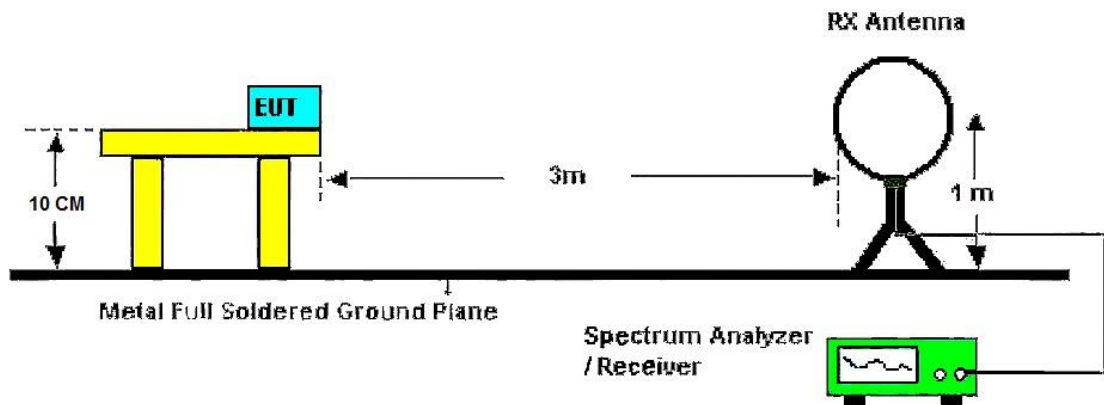

Below 30MHz Test Setup

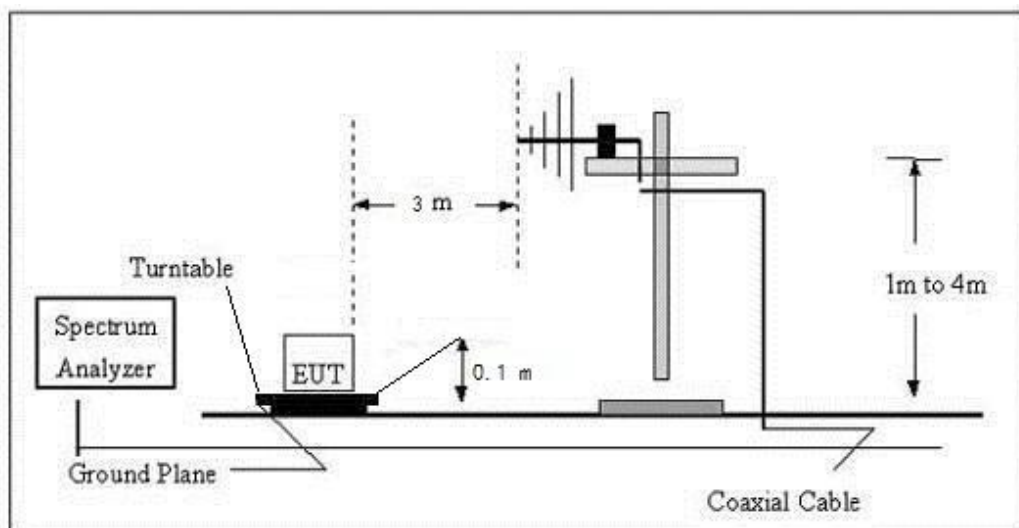

Below 1000MHz Test Setup

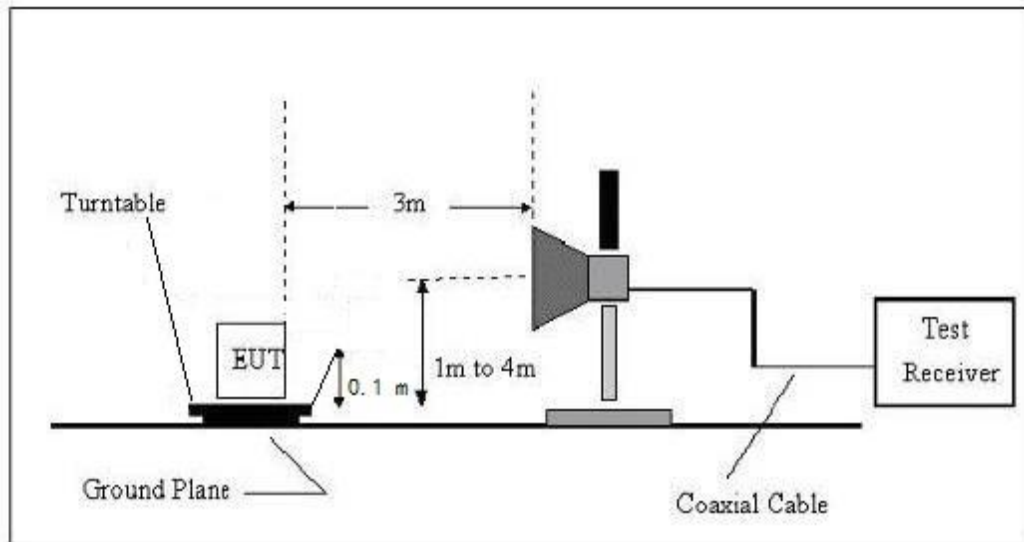

Above 1GHz Test Setup

### Test Procedure

1. The EUT was setup and tested according to ANSI C63.10:2013
  2. The EUT is placed on a turn table which is 0.1 meter above ground for below 1 GHz, and 0.1 m for above 1 GHz. The turn table is rotated 360 degrees to determine the position of the maximum emission level.
  3. The EUT was set 3 meters from the receiving antenna, which was mounted on the top of a variable height antenna tower.
  4. For each suspected emission, the EUT was arranged to its worst case and then tune the Antenna tower (from 1 m to 4 m) and turntable (from 0 degree to 360 degrees) to find the maximum reading. A pre-amp and a high pass filter are used for the test in order to get better signal level to comply with the guidelines.
  5. Set to the maximum power setting and enable the EUT transmit continuously.
  6. Use the following spectrum analyzer settings
    - (1) Span shall wide enough to fully capture the emission being measured;
    - (2) 9k – 150kHz:  
RBW=300 Hz, VBW=1 kHz, Sweep=auto, Detector function=peak, Trace=max hold
    - (3) 0.15M – 30MHz:  
RBW=10 kHz, VBW=30 kHz, Sweep=auto, Detector function=peak, Trace=max hold
    - (4) 30M - 1 GHz:  
RBW=120 kHz, VBW=300 kHz, Sweep=auto, Detector function=peak, Trace=max holdIf the emission level of the EUT measured by the peak detector is 3 dB lower than the applicable limit, the peak emission level will be reported. Otherwise, the emission measurement will be repeated using the quasi-peak detector and reported.
  - (5) From 1 GHz to 10th harmonic:  
RBW=1MHz, VBW=3MHz Peak detector for Peak value.  
RBW=1MHz, VBW see note 1 with Peak Detector for Average Value.
- Note 1: For measurements above 1 GHz the resolution bandwidth is set to 1 MHz, then the video bandwidth is set to 3 MHz for peak measurements and 1 MHz resolution bandwidth with 1/T video bandwidth with peak detector for average measurements. For the Duty Cycle please refer to clause 3.8 Duty Cycle.

### Test Mode

Please refer to the clause 2.4.

### Test Result

#### **9 KHz~30 MHz**

From 9 KHz to 30 MHz: Conclusion: PASS

Note: The amplitude of spurious emissions which are attenuated by more than 20dB below the permissible value has no need to be reported.



30MHz-1GHz

|            |                              |
|------------|------------------------------|
| Ant. Pol.  | Horizontal                   |
| Test Mode: | TX BLE 1M Mode 2402MHz       |
| Remark:    | Only worse case is reported. |

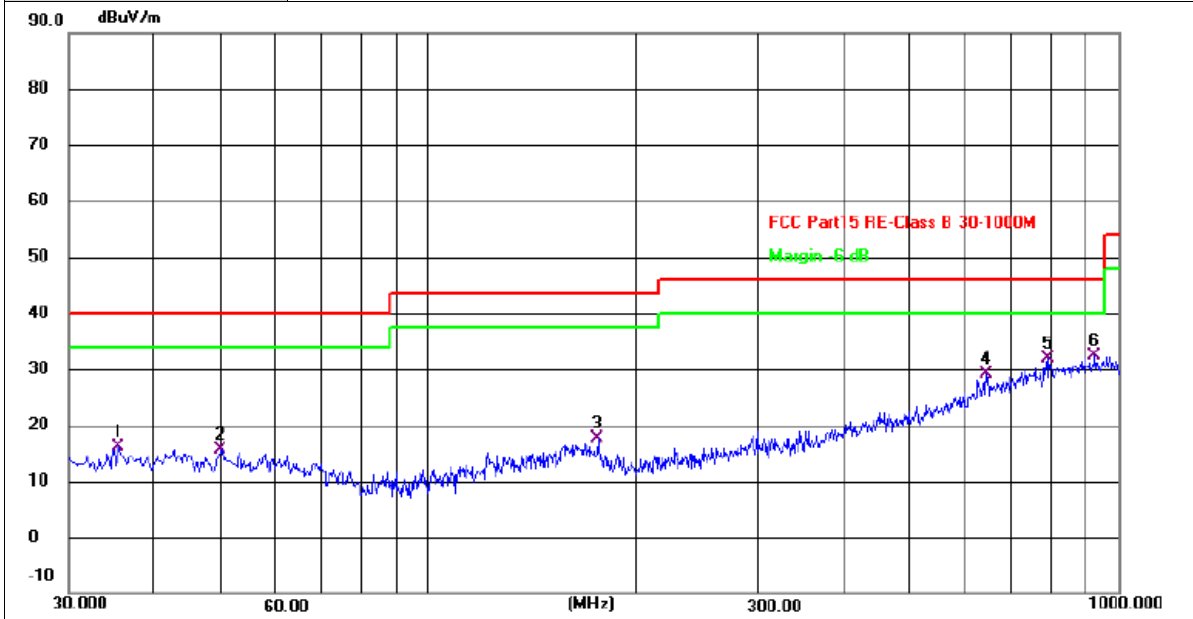

| No. | Frequency (MHz) | Reading (dBuV) | Factor (dB/m) | Level (dBuV/m) | Limit (dBuV/m) | Margin (dB) | Detector |
|-----|-----------------|----------------|---------------|----------------|----------------|-------------|----------|
| 1   | 35.4966         | 32.36          | -16.26        | 16.10          | 40.00          | -23.90      | QP       |
| 2   | 50.0466         | 32.13          | -16.41        | 15.72          | 40.00          | -24.28      | QP       |
| 3   | 176.1465        | 34.88          | -17.24        | 17.64          | 43.50          | -25.86      | QP       |
| 4   | 643.6866        | 35.91          | -6.82         | 29.09          | 46.00          | -16.91      | QP       |
| 5   | 792.4200        | 35.91          | -3.93         | 31.98          | 46.00          | -14.02      | QP       |
| 6 * | 923.6933        | 34.53          | -2.23         | 32.30          | 46.00          | -13.70      | QP       |

Remarks:

1. Factor (dB/m) = Antenna Factor (dB/m)+Cable Factor (dB)-Pre-amplifier Factor
2. Margin value = Level -Limit value



|                   |                              |
|-------------------|------------------------------|
| <b>Ant. Pol.</b>  | Vertical                     |
| <b>Test Mode:</b> | TX BLE 1M Mode 2402MHz       |
| <b>Remark:</b>    | Only worse case is reported. |

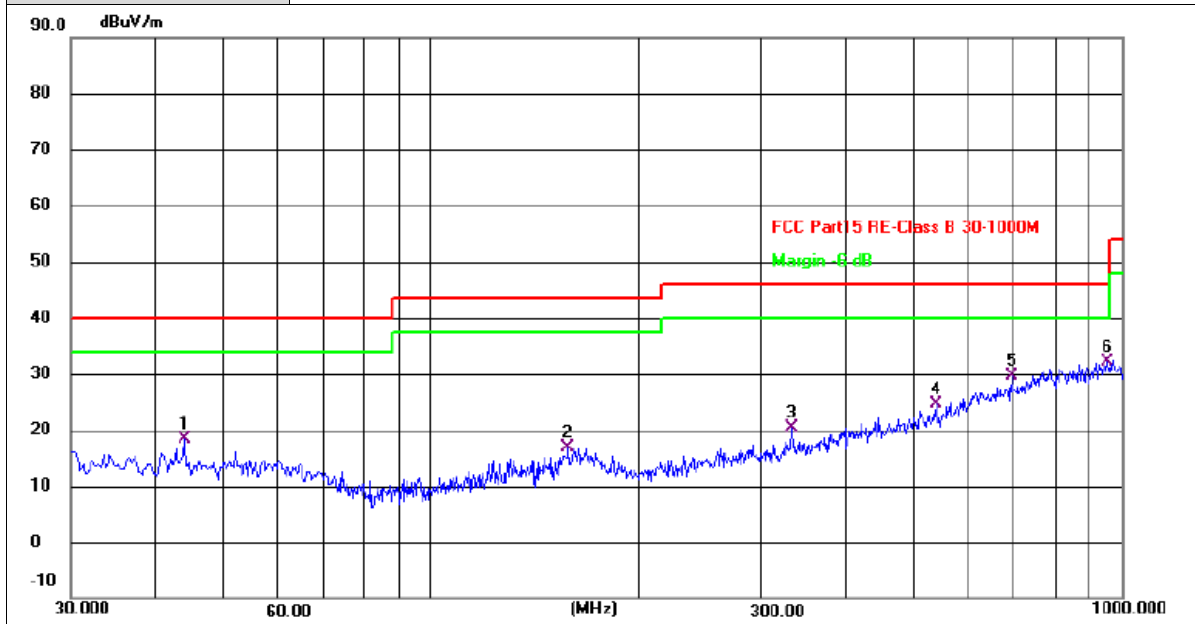

| No. | Frequency (MHz) | Reading (dBuV) | Factor (dB/m) | Level (dBuV/m) | Limit (dBuV/m) | Margin (dB) | Detector |
|-----|-----------------|----------------|---------------|----------------|----------------|-------------|----------|
| 1   | 43.9033         | 34.54          | -16.13        | 18.41          | 40.00          | -21.59      | QP       |
| 2   | 157.7166        | 32.91          | -16.06        | 16.85          | 43.50          | -26.65      | QP       |
| 3   | 332.6400        | 35.14          | -14.81        | 20.33          | 46.00          | -25.67      | QP       |
| 4   | 538.2800        | 34.27          | -9.52         | 24.75          | 46.00          | -21.25      | QP       |
| 5   | 692.8333        | 35.67          | -6.08         | 29.59          | 46.00          | -16.41      | QP       |
| 6 * | 952.1466        | 33.77          | -1.66         | 32.11          | 46.00          | -13.89      | QP       |

Remarks:

1. Factor (dB/m) = Antenna Factor (dB/m)+Cable Factor (dB)-Pre-amplifier Factor
2. Margin value = Level -Limit value





Above 1GHz

|                   |  |
|-------------------|--|
| <b>Ant. Pol.</b>  | Horizontal   |
| <b>Test Mode:</b> | TX BLE 1M Mode 2402MHz   |
| <b>Remark:</b>    | No report for the emission which more than 20 dB below the prescribed limit. |

| No. | Frequency (MHz) | Reading (dBUV) | Factor (dB/m) | Level (dBUV/m) | Limit (dBUV/m) | Margin (dB) | Detector |
|-----|-----------------|----------------|---------------|----------------|----------------|-------------|----------|
| 1   | 4920.583        | 42.85          | 2.15          | 45.00          | 74.00          | -29.00      | peak     |
| 2   | 7211.833        | 39.42          | 10.03         | 49.45          | 74.00          | -24.55      | peak     |
| 3   | 8711.917        | 40.53          | 11.23         | 51.76          | 74.00          | -22.24      | peak     |
| 4   | 9663.667        | 39.31          | 12.70         | 52.01          | 74.00          | -21.99      | peak     |
| 5   | 10443.083       | 38.91          | 13.91         | 52.82          | 74.00          | -21.18      | peak     |
| 6 * | 12115.500       | 37.90          | 15.60         | 53.50          | 74.00          | -20.50      | peak     |

Remarks:  
 1.Factor (dB/m) = Antenna Factor (dB/m)+Cable Factor (dB)-Pre-amplifier Factor  
 2.Margin value = Level -Limit value

|                   |  |
|-------------------|--|
| <b>Ant. Pol.</b>  | Vertical   |
| <b>Test Mode:</b> | TX BLE 1M Mode 2402MHz   |
| <b>Remark:</b>    | No report for the emission which more than 20 dB below the prescribed limit. |

| No. | Frequency (MHz) | Reading (dBUV) | Factor (dB/m) | Level (dBUV/m) | Limit (dBUV/m) | Margin (dB) | Detector |
|-----|-----------------|----------------|---------------|----------------|----------------|-------------|----------|
| 1   | 4814.833        | 43.13          | 2.00          | 45.13          | 74.00          | -28.87      | peak     |
| 2   | 6530.333        | 39.91          | 7.40          | 47.31          | 74.00          | -26.69      | peak     |
| 3   | 8042.167        | 40.03          | 10.76         | 50.79          | 74.00          | -23.21      | peak     |
| 4   | 9150.583        | 39.98          | 12.20         | 52.18          | 74.00          | -21.82      | peak     |
| 5 * | 10431.333       | 39.58          | 13.91         | 53.49          | 74.00          | -20.51      | peak     |
| 6   | 12095.917       | 37.64          | 15.58         | 53.22          | 74.00          | -20.78      | peak     |

Remarks:  
 1.Factor (dB/m) = Antenna Factor (dB/m)+Cable Factor (dB)-Pre-amplifier Factor  
 2.Margin value = Level -Limit value



|                   |  |
|-------------------|--|
| <b>Ant. Pol.</b>  | Horizontal   |
| <b>Test Mode:</b> | TX BLE 1M Mode 2440MHz   |
| <b>Remark:</b>    | No report for the emission which more than 20 dB below the prescribed limit. |

| No. | Frequency (MHz) | Reading (dBuV) | Factor (dB/m) | Level (dBuV/m) | Limit (dBuV/m) | Margin (dB) | Detector |
|-----|-----------------|----------------|---------------|----------------|----------------|-------------|----------|
| 1   | 6495.083        | 39.38          | 7.31          | 46.69          | 74.00          | -27.31      | peak     |
| 2   | 7650.500        | 40.57          | 10.16         | 50.73          | 74.00          | -23.27      | peak     |
| 3   | 8790.250        | 40.41          | 11.39         | 51.80          | 74.00          | -22.20      | peak     |
| 4   | 9789.000        | 39.55          | 12.92         | 52.47          | 74.00          | -21.53      | peak     |
| 5   | 11590.667       | 38.20          | 15.12         | 53.32          | 74.00          | -20.68      | peak     |
| 6 * | 12722.583       | 37.06          | 16.37         | 53.43          | 74.00          | -20.57      | peak     |

## Remarks:

1.Factor (dB/m) = Antenna Factor (dB/m)+Cable Factor (dB)-Pre-amplifier Factor

2.Margin value = Level -Limit value

|                   |  |
|-------------------|--|
| <b>Ant. Pol.</b>  | Vertical   |
| <b>Test Mode:</b> | TX BLE 1M Mode 2440MHz   |
| <b>Remark:</b>    | No report for the emission which more than 20 dB below the prescribed limit. |

| No. | Frequency (MHz) | Reading (dBuV) | Factor (dB/m) | Level (dBuV/m) | Limit (dBuV/m) | Margin (dB) | Detector |
|-----|-----------------|----------------|---------------|----------------|----------------|-------------|----------|
| 1   | 5167.333        | 42.11          | 2.78          | 44.89          | 74.00          | -29.11      | peak     |
| 2   | 7129.583        | 40.13          | 9.64          | 49.77          | 74.00          | -24.23      | peak     |
| 3   | 7779.750        | 40.84          | 10.38         | 51.22          | 74.00          | -22.78      | peak     |
| 4   | 9150.583        | 39.87          | 12.20         | 52.07          | 74.00          | -21.93      | peak     |
| 5   | 10830.833       | 38.05          | 14.50         | 52.55          | 74.00          | -21.45      | peak     |
| 6 * | 12150.750       | 37.73          | 15.66         | 53.39          | 74.00          | -20.61      | peak     |

## Remarks:

1.Factor (dB/m) = Antenna Factor (dB/m)+Cable Factor (dB)-Pre-amplifier Factor

2.Margin value = Level -Limit value



|                   |  |
|-------------------|--|
| <b>Ant. Pol.</b>  | Horizontal   |
| <b>Test Mode:</b> | TX BLE 1M Mode 2480MHz   |
| <b>Remark:</b>    | No report for the emission which more than 20 dB below the prescribed limit. |

| No. | Frequency (MHz) | Reading (dBuV) | Factor (dB/m) | Level (dBuV/m) | Limit (dBuV/m) | Margin (dB) | Detector |
|-----|-----------------|----------------|---------------|----------------|----------------|-------------|----------|
| 1   | 3855.250        | 41.93          | -0.03         | 41.90          | 74.00          | -32.10      | peak     |
| 2   | 5797.917        | 42.07          | 4.93          | 47.00          | 74.00          | -27.00      | peak     |
| 3   | 7924.667        | 40.33          | 10.71         | 51.04          | 74.00          | -22.96      | peak     |
| 4   | 9248.500        | 40.10          | 12.41         | 52.51          | 74.00          | -21.49      | peak     |
| 5   | 11199.000       | 38.21          | 14.76         | 52.97          | 74.00          | -21.03      | peak     |
| 6 * | 12362.250       | 37.90          | 15.54         | 53.44          | 74.00          | -20.56      | peak     |

## Remarks:

- 1.Factor (dB/m) = Antenna Factor (dB/m)+Cable Factor (dB)-Pre-amplifier Factor
- 2.Margin value = Level -Limit value

|                   |  |
|-------------------|--|
| <b>Ant. Pol.</b>  | Vertical   |
| <b>Test Mode:</b> | TX BLE 1M Mode 2480MHz   |
| <b>Remark:</b>    | No report for the emission which more than 20 dB below the prescribed limit. |

| No. | Frequency (MHz) | Reading (dBuV) | Factor (dB/m) | Level (dBuV/m) | Limit (dBuV/m) | Margin (dB) | Detector |
|-----|-----------------|----------------|---------------|----------------|----------------|-------------|----------|
| 1   | 4309.583        | 42.64          | 0.94          | 43.58          | 74.00          | -30.42      | peak     |
| 2   | 6369.750        | 39.39          | 6.94          | 46.33          | 74.00          | -27.67      | peak     |
| 3   | 7681.833        | 41.53          | 10.20         | 51.73          | 74.00          | -22.27      | peak     |
| 4   | 9225.000        | 40.45          | 12.39         | 52.84          | 74.00          | -21.16      | peak     |
| 5   | 10834.750       | 38.41          | 14.50         | 52.91          | 74.00          | -21.09      | peak     |
| 6 * | 11990.167       | 37.88          | 15.44         | 53.32          | 74.00          | -20.68      | peak     |

## Remarks:

- 1.Factor (dB/m) = Antenna Factor (dB/m)+Cable Factor (dB)-Pre-amplifier Factor
- 2.Margin value = Level -Limit value

### 3.3. Band Edge Emissions (Radiated)

#### Limit

FCC CFR Title 47 Part 15 Subpart C Section 15.247 (d)/ RSS 247 5.5:

| Restricted Frequency Band (MHz) | (dBuV/m)(at 3m) |         |
|---------------------------------|-----------------|---------|
|                                 | Peak            | Average |
| 2310 ~ 2390                     | 74              | 54      |
| 2483.5 ~ 2500                   | 74              | 54      |

#### Test Configuration

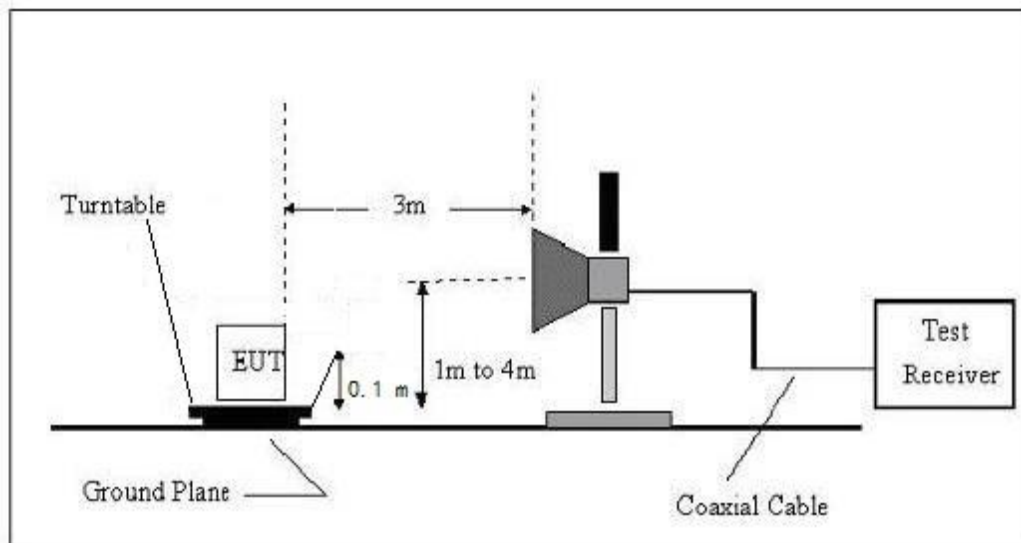

#### Test Procedure

1. The EUT was setup and tested according to ANSI C63.10:2013 requirements.
2. The EUT is placed on a turn table which is 0.1 meter above ground. The turn table is rotated 360 degrees to determine the position of the maximum emission level.
3. The EUT was positioned such that the distance from antenna to the EUT was 3 meters.
4. The antenna is scanned from 1 meter to 4 meters to find out the maximum emission level. This is repeated for both horizontal and vertical polarization of the antenna. In order to find the maximum emission, all of the interface cables were manipulated according to ANSI C63.10:2013 on radiated measurement.
5. The receiver set as follow:  
 RBW=1MHz, VBW=3MHz Peak detector for Peak value.  
 RBW=1MHz, VBW see note 1 with Peak Detector for Average Value.

Note 1: For measurements above 1 GHz the resolution bandwidth is set to 1 MHz, then the video bandwidth is set to 3 MHz for peak measurements and 1 MHz resolution bandwidth with 1/T video bandwidth with peak detector for average measurements. For the Duty Cycle please refer to clause 3.8 Duty Cycle.

#### Test Mode

Please refer to the clause 2.4.



**Test Results**

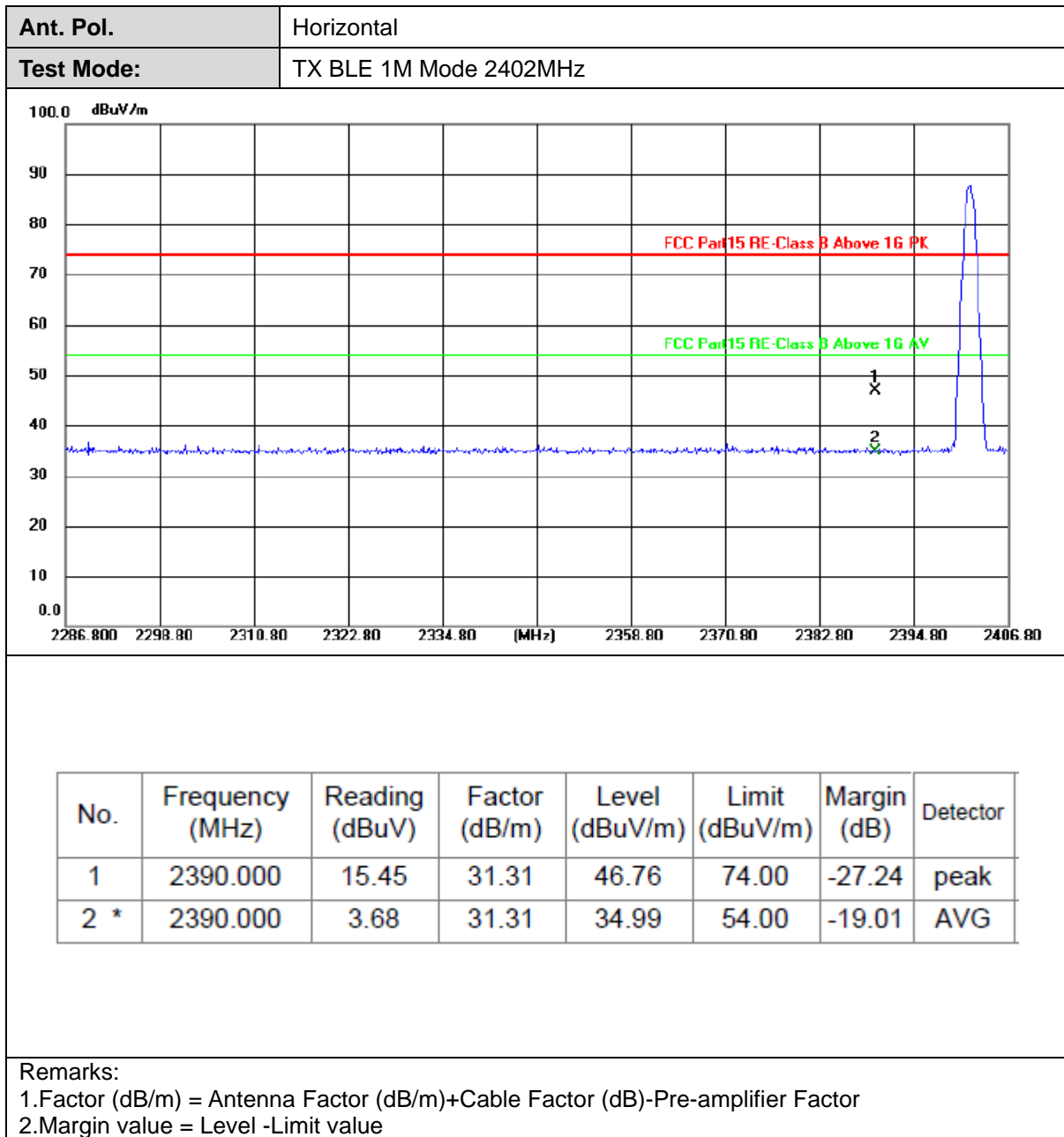



|            |                        |
|------------|------------------------|
| Ant. Pol.  | Vertical               |
| Test Mode: | TX BLE 1M Mode 2402MHz |

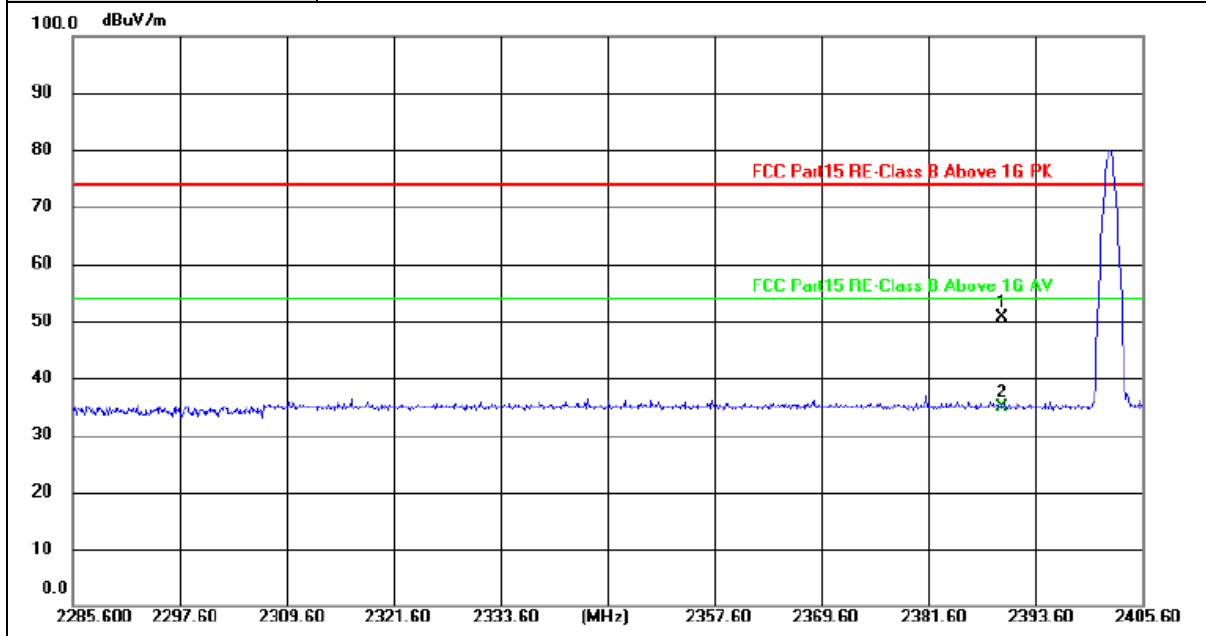

| No. | Frequency (MHz) | Reading (dBUV) | Factor (dB/m) | Level (dBUV/m) | Limit (dBUV/m) | Margin (dB) | Detector |
|-----|-----------------|----------------|---------------|----------------|----------------|-------------|----------|
| 1   | 2390.000        | 19.34          | 31.31         | 50.65          | 74.00          | -23.35      | peak     |
| 2 * | 2390.000        | 3.54           | 31.31         | 34.85          | 54.00          | -19.15      | AVG      |

Remarks:

- 1. Factor (dB/m) = Antenna Factor (dB/m)+Cable Factor (dB)-Pre-amplifier Factor
- 2. Margin value = Level -Limit value



|            |                        |
|------------|------------------------|
| Ant. Pol.  | Horizontal             |
| Test Mode: | TX BLE 1M Mode 2480MHz |

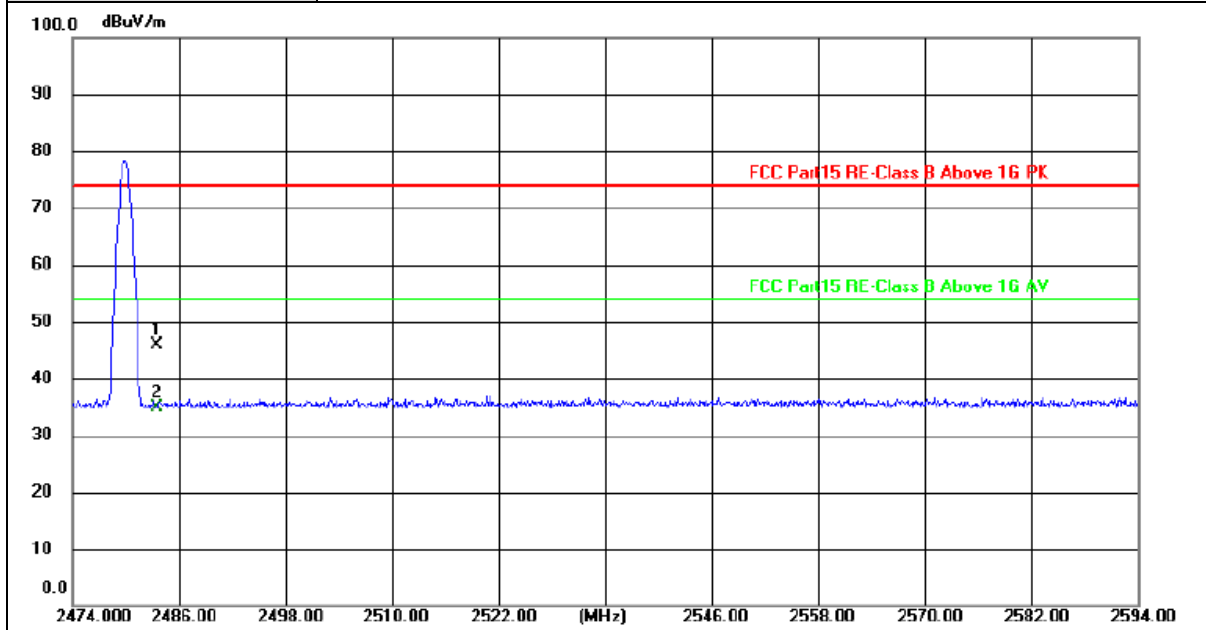

| No. | Frequency (MHz) | Reading (dBuV) | Factor (dB/m) | Level (dBuV/m) | Limit (dBuV/m) | Margin (dB) | Detector |
|-----|-----------------|----------------|---------------|----------------|----------------|-------------|----------|
| 1   | 2483.500        | 14.47          | 31.48         | 45.95          | 74.00          | -28.05      | peak     |
| 2 * | 2483.500        | 3.47           | 31.48         | 34.95          | 54.00          | -19.05      | AVG      |

Remarks:

- 1. Factor (dB/m) = Antenna Factor (dB/m)+Cable Factor (dB)-Pre-amplifier Factor
- 2. Margin value = Level -Limit value



|            |                        |
|------------|------------------------|
| Ant. Pol.  | Vertical               |
| Test Mode: | TX BLE 1M Mode 2480MHz |

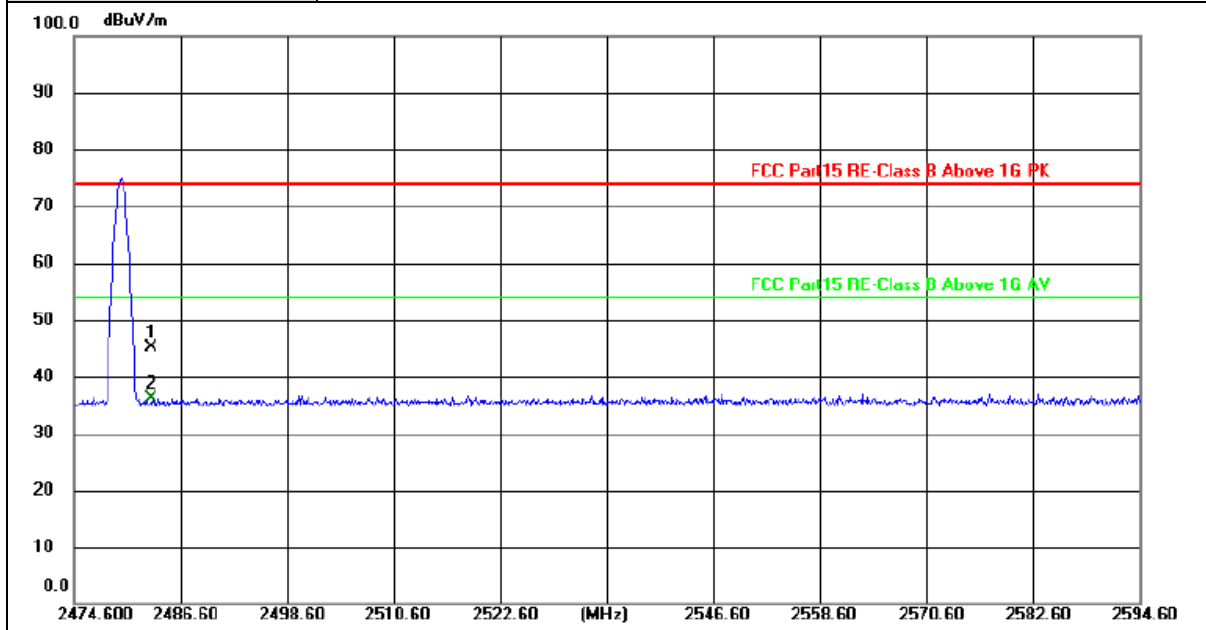

| No. | Frequency (MHz) | Reading (dBuV) | Factor (dB/m) | Level (dBuV/m) | Limit (dBuV/m) | Margin (dB) | Detector |
|-----|-----------------|----------------|---------------|----------------|----------------|-------------|----------|
| 1   | 2483.500        | 13.62          | 31.48         | 45.10          | 74.00          | -28.90      | peak     |
| 2 * | 2483.500        | 4.76           | 31.48         | 36.24          | 54.00          | -17.76      | AVG      |

Remarks:

- 1. Factor (dB/m) = Antenna Factor (dB/m)+Cable Factor (dB)-Pre-amplifier Factor
- 2. Margin value = Level -Limit value



### 3.4. Band edge and Spurious Emissions (Conducted)

#### Limit

FCC CFR Title 47 Part 15 Subpart C Section 15.247 (d): In any 100 kHz bandwidth outside the frequency band in which the spread spectrum intentional radiator is operating, the radio frequency power that is produced by the intentional radiator shall be at least 20 dB below that in the 100 kHz bandwidth within the band that contains the highest level of the desired power, based on either an RF conducted or a radiated measurement.

#### Test Configuration

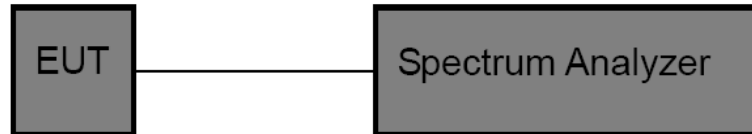

#### Test Procedure

1. The transmitter output was connected to the spectrum analyzer through an attenuator, the path loss was compensated to the results for each measurement.
2. Set to the maximum power setting and enable the EUT transmit continuously
3. Use the following spectrum analyzer settings:  
RBW = 100 kHz, VBW  $\geq$  RBW, scan up through 10<sup>th</sup> harmonic.  
Sweep = auto, Detector function = peak, Trace = max hold
4. Measure and record the results in the test report.

#### Test Mode

Please refer to the clause 2.4.

#### Test Results

##### (1) Band edge Conducted Test

| Test Mode | Frequency[MHz] | Ref Level[dBm] | Result[dBm] | Limit[dBm]    | Verdict |
|-----------|----------------|----------------|-------------|---------------|---------|
| BLE 1M    | 2402           | -1.58          | -51.43      | $\leq$ -21.58 | PASS    |
|           | 2480           | -1.50          | -54.38      | $\leq$ -21.50 | PASS    |



Test Graphs

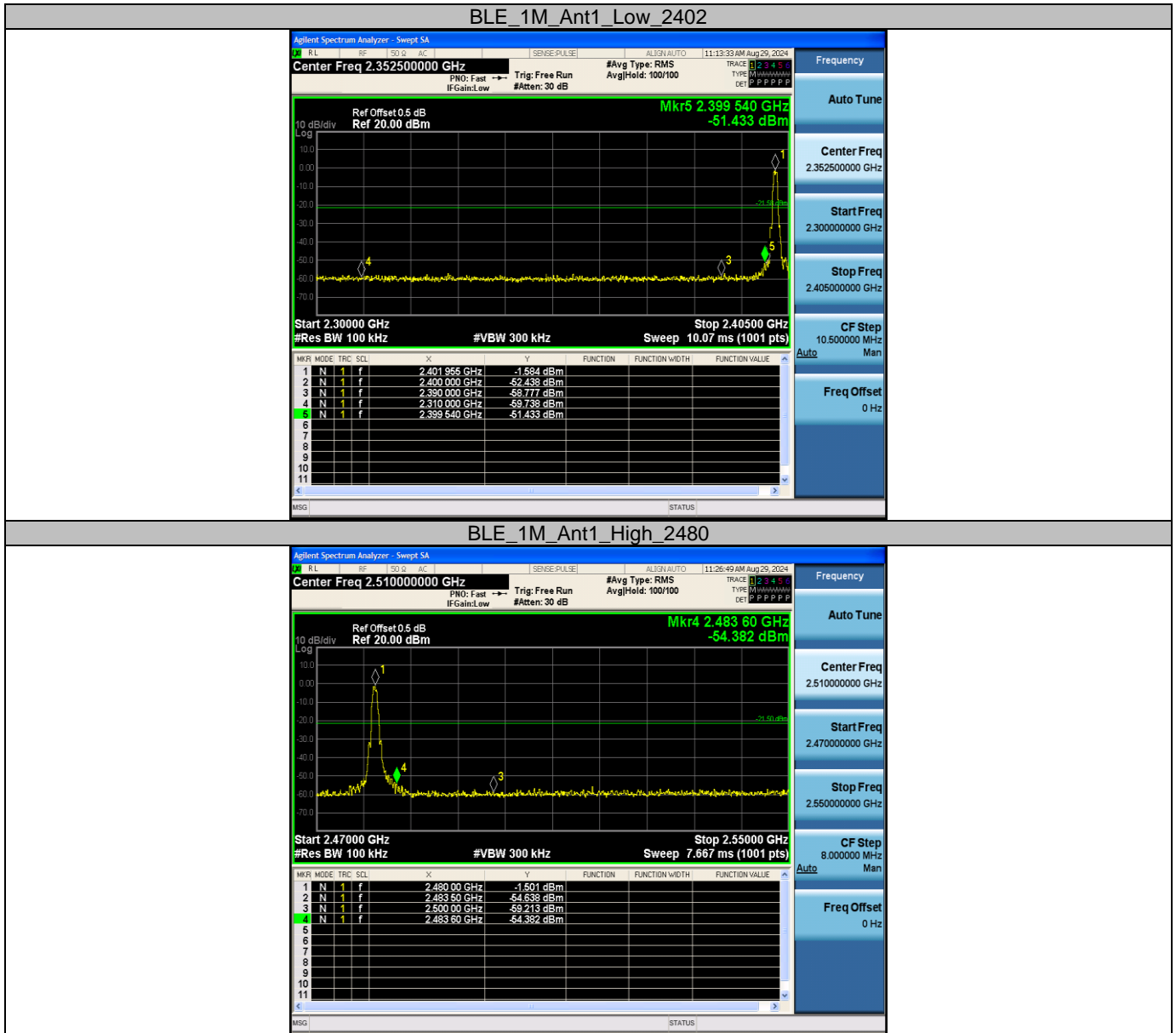



(2) Conducted Spurious Emissions Test

| Test Mode | Frequency [MHz] | Freq. Range [MHz] | Ref Level [dBm] | Result[dBm] | Limit[dBm] | Verdict |
|-----------|-----------------|-------------------|-----------------|-------------|------------|---------|
| BLE 1M    | 2402            | Reference         | -2.00           | -2.00       | ---        | PASS    |
|           |                 | 30~1000           | -2.00           | -62.41      | ≤-22.00    | PASS    |
|           |                 | 1000~26500        | -2.00           | -32.31      | ≤-22.00    | PASS    |
|           | 2440            | Reference         | -2.83           | -2.83       | ---        | PASS    |
|           |                 | 30~1000           | -2.83           | -63.33      | ≤-22.83    | PASS    |
|           |                 | 1000~26500        | -2.83           | -35.63      | ≤-22.83    | PASS    |
|           | 2480            | Reference         | -2.50           | -2.50       | ---        | PASS    |
|           |                 | 30~1000           | -2.50           | -62.84      | ≤-22.50    | PASS    |
|           |                 | 1000~26500        | -2.50           | -34.29      | ≤-22.50    | PASS    |



Test Graphs

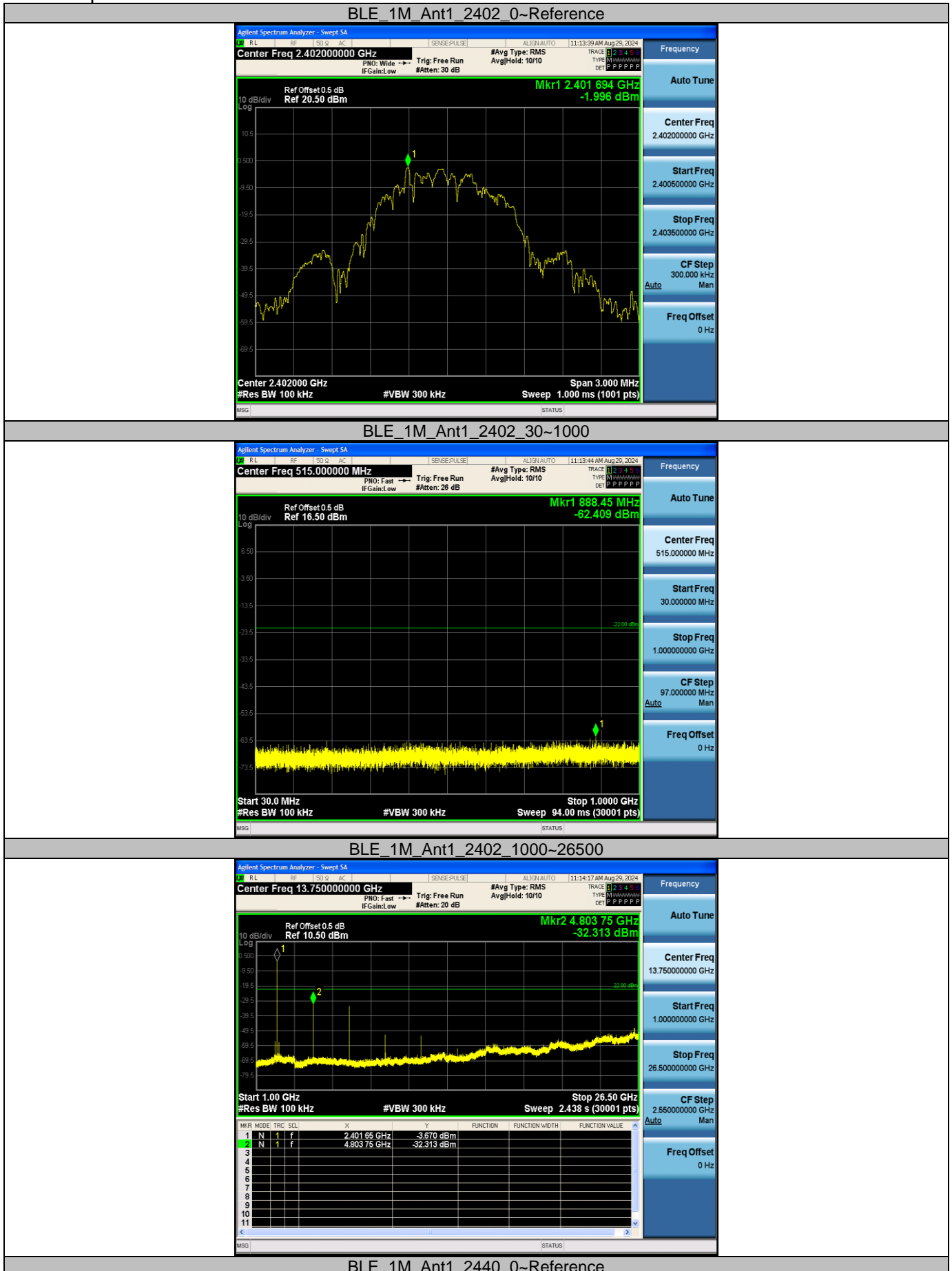



BLE\_1M\_Ant1\_2440\_30~1000

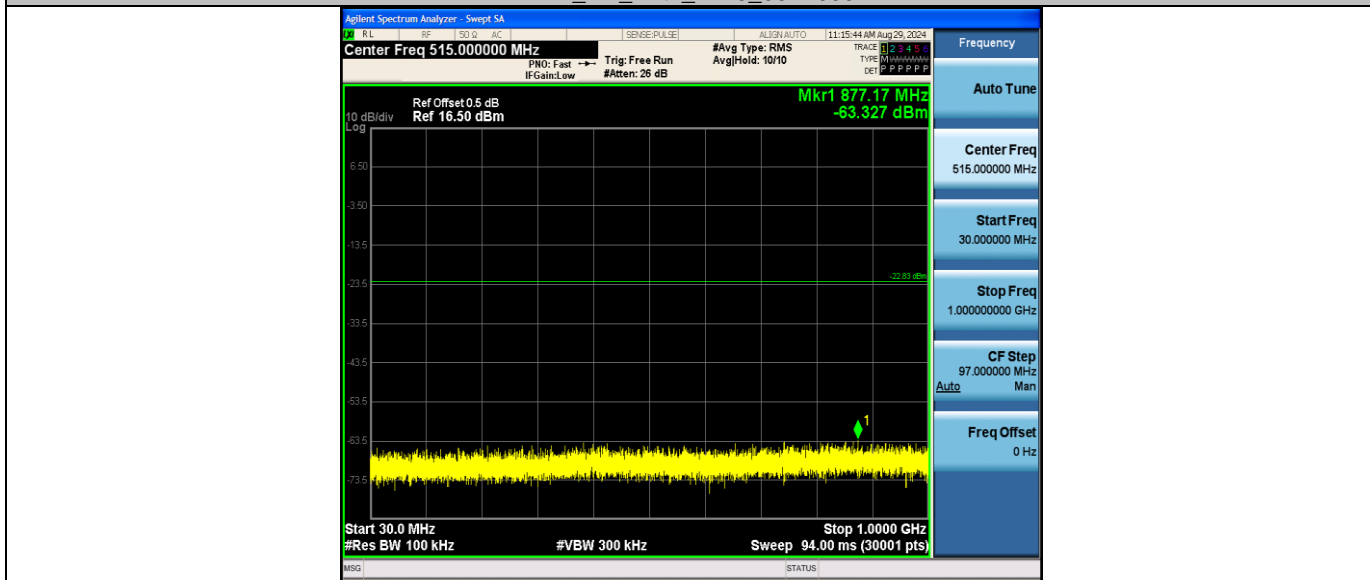

BLE\_1M\_Ant1\_2440\_1000~26500

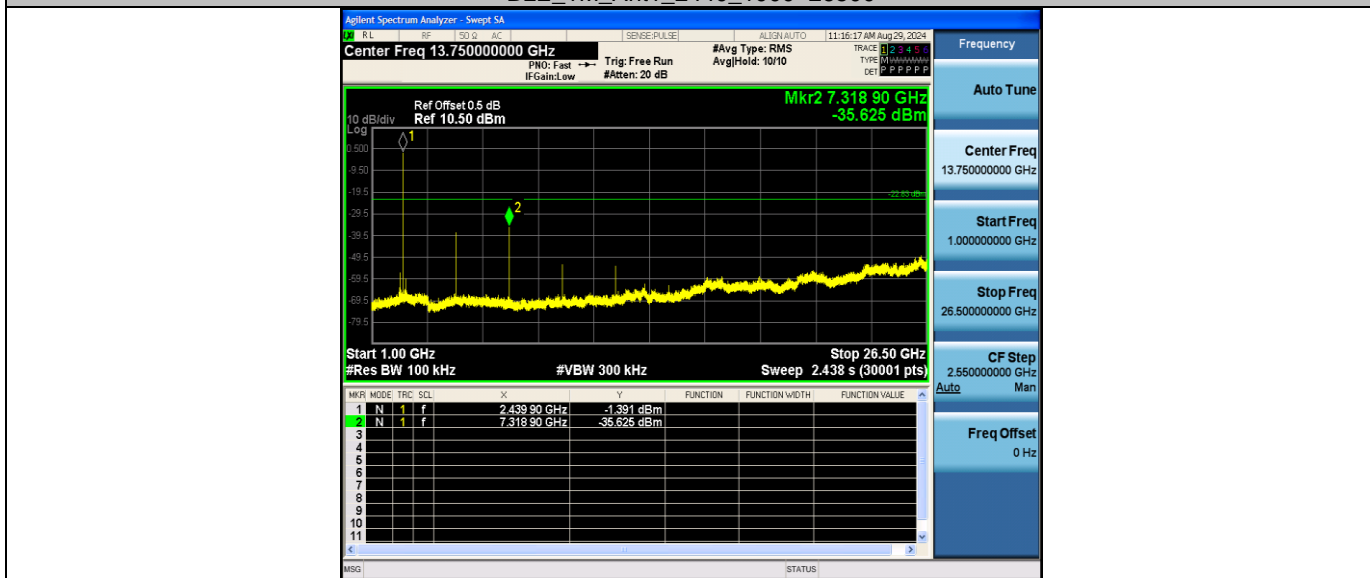

BLE\_1M\_Ant1\_2480\_0~Reference



BLE\_1M\_Ant1\_2480\_30~1000

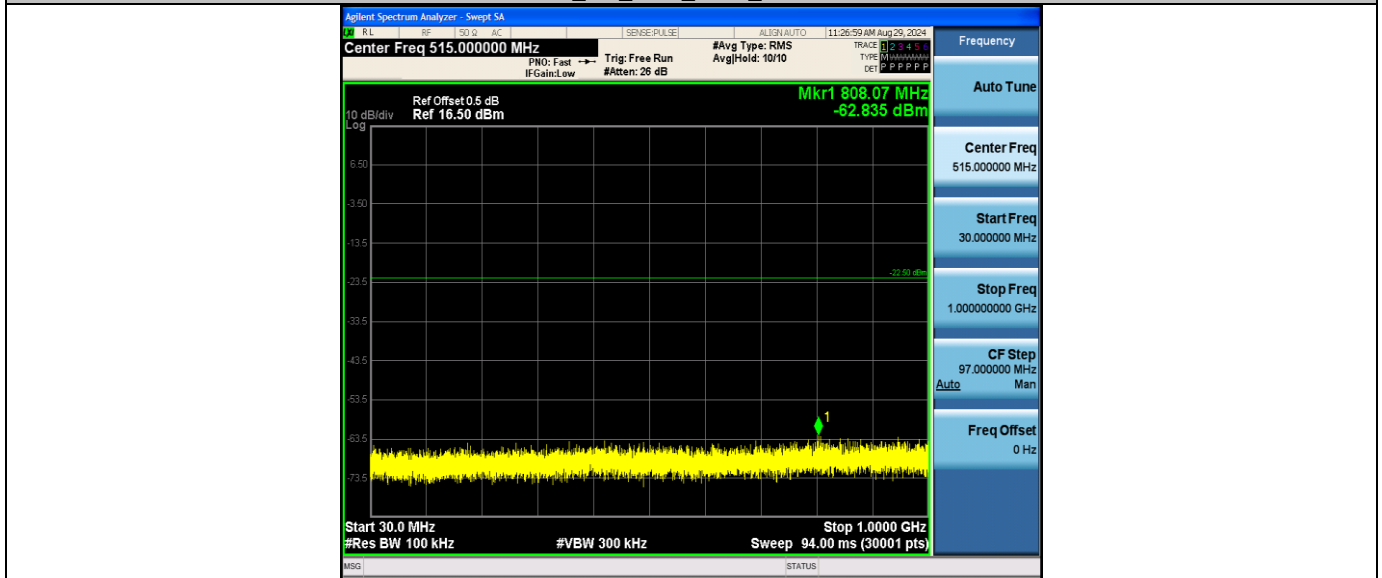

BLE\_1M\_Ant1\_2480\_1000~26500

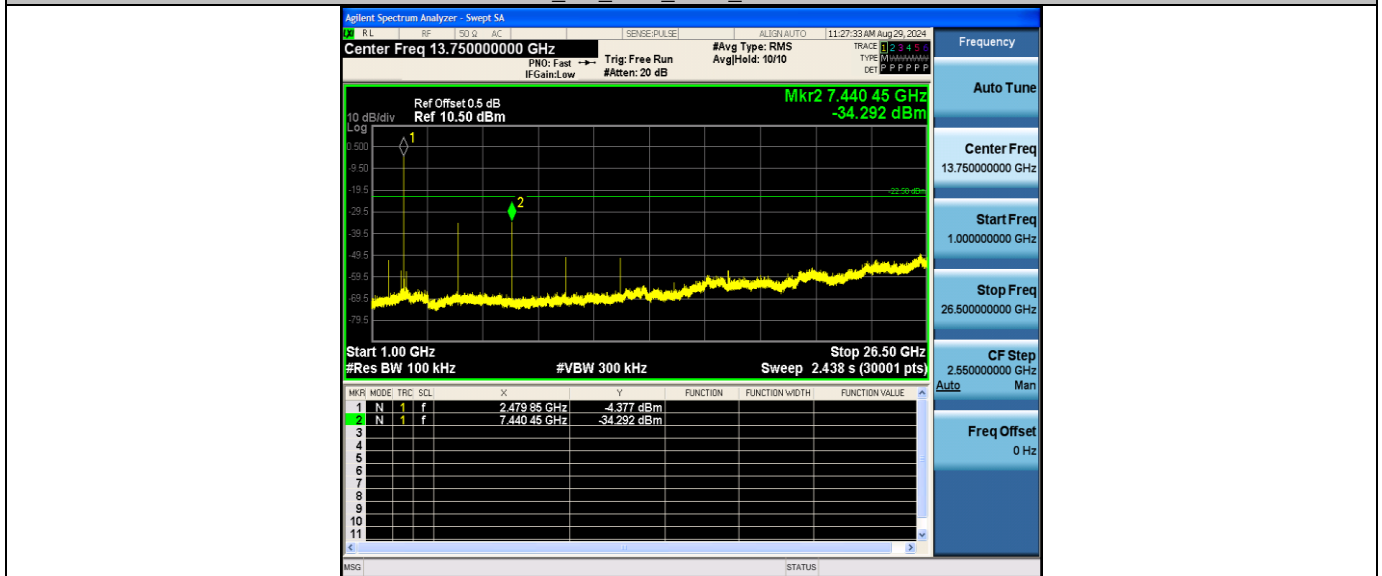



### 3.5. Bandwidth

#### Limit

FCC CFR Title 47 Part 15 Subpart C Section 15.247 (a)(2)/ RSS-247 5.2 a:

| Test Item     | Limit                       | Frequency Range(MHz) |
|---------------|-----------------------------|----------------------|
| DTS Bandwidth | ≥500 KHz<br>(6dB bandwidth) | 2400~2483.5          |

#### Test Configuration

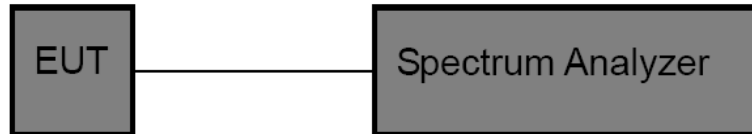

#### Test Procedure

- The EUT was directly connected to the spectrum analyzer and antenna output port as show in the block diagram above.
- DTS Spectrum Setting:
  - Set RBW = 100 kHz.
  - Set the video bandwidth (VBW) ≥ 3 RBW.
  - Detector = Peak.
  - Trace mode = Max hold.
  - Sweep = Auto couple.
- OCB Spectrum Setting:
  - Set RBW = 1% ~ 5% occupied bandwidth.
  - Set the video bandwidth (VBW) ≥ 3 RBW.
  - Detector = Peak.
  - Trace mode = Max hold.
  - Sweep = Auto couple.

#### Test Mode

Please refer to the clause 2.4.

#### Test Results

| Test Mode | Frequency[MHz] | OBW[MHz] | DTS BW[MHz] | Limit[MHz] | Verdict |
|-----------|----------------|----------|-------------|------------|---------|
| BLE 1M    | 2402           | 1.0428   | 0.672       | ≥0.5       | PASS    |
|           | 2440           | 1.0452   | 0.692       | ≥0.5       | PASS    |
|           | 2480           | 1.0517   | 0.656       | ≥0.5       | PASS    |



Occupied Bandwidth



CTC Laboratories, Inc.

Room 101 Building B, No. 7, Lanqing 1st Road, Luhu Community, Guanhu Subdistrict, Longhua District, Shenzhen, Guangdong, China  
Tel.: (86)755-27521059 Fax: (86)755-27521011 Http://www.sz-ctc.org.cn



For anti-fake verification, please visit the official website of Certification and Accreditation Administration of the People's Republic of China : [yz.cnca.cn](http://yz.cnca.cn)





DTS Bandwidth



CTC Laboratories, Inc.

Room 101 Building B, No. 7, Lanqing 1st Road, Luhu Community, Guanhu Subdistrict, Longhua District, Shenzhen, Guangdong, China  
 Tel.: (86)755-27521059 Fax: (86)755-27521011 Http://www.sz-ctc.org.cn



For anti-fake verification, please visit the official website of Certification and Accreditation Administration of the People's Republic of China : [yz.cnca.cn](http://yz.cnca.cn)



### 3.6. Peak Output Power

#### Limit

FCC CFR Title 47 Part 15 Subpart C Section 15.247 (b)(3)/ RSS-247 5.4 d:

| Section                 | Test Item                      | Limit           | Frequency Range(MHz) |
|-------------------------|--------------------------------|-----------------|----------------------|
| CFR 47 FCC 15.247(b)(3) | Maximum conducted output power | 1 Watt or 30dBm | 2400~2483.5          |
| ISED RSS-247 5.4 d      | EIRP                           | 4 Watt or 36dBm | 2400~2483.5          |

#### Test Configuration

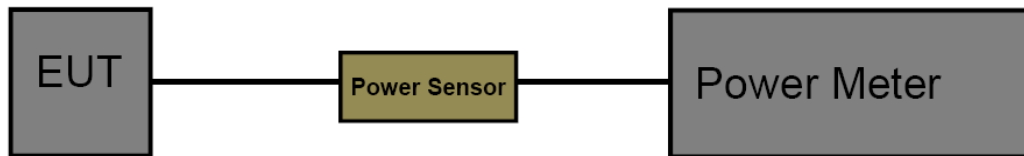

#### Test Procedure

1. The maximum conducted output power may be measured using a broadband Peak RF power meter.
2. Peak power measurements were performed only when the EUT was transmitting at its maximum power control level using a broadband power meter with a pulse sensor.
3. The power meter implemented triggering and gating capabilities which were set up such that power measurements were recorded only during the ON time of the transmitter.
4. Record the measurement data.

#### Test Mode

Please refer to the clause 2.4.

#### Test Result

| Test Mode | Frequency[MHz] | Conducted Peak Power[dBm] | Conducted Limit[dBm] | EIRP [dBm] | EIRP Limit[dBm] | Verdict |
|-----------|----------------|---------------------------|----------------------|------------|-----------------|---------|
| BLE 1M    | 2402           | -1.45                     | ≤30.00               | -0.95      | ≤36.00          | PASS    |
|           | 2440           | -1.11                     | ≤30.00               | -0.61      | ≤36.00          | PASS    |
|           | 2480           | -1.23                     | ≤30.00               | -0.73      | ≤36.00          | PASS    |



### 3.7. Power Spectral Density

#### Limit

FCC CFR Title 47 Part 15 Subpart C Section 15.247 (e)/ RSS-247 5.2 b:

| Test Item              | Limit              | Frequency Range(MHz) |
|------------------------|--------------------|----------------------|
| Power Spectral Density | 8dBm(in any 3 kHz) | 2400~2483.5          |

#### Test Configuration

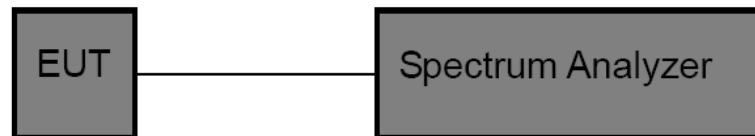

#### Test Procedure

- The EUT was directly connected to the spectrum analyzer and antenna output port as show in the block diagram above.
- The EUT was directly connected to the Spectrum Analyzer and antenna output port as show in the block diagram above. The measurement according to section 10.2 of KDB 558074 D01 DTS Meas Guidance v05r02.
- Spectrum Setting:  
 Set analyzer center frequency to DTS channel center frequency.  
 Set the span to 1.5 times the DTS bandwidth.  
 Set the RBW to: 3 kHz  
 Set the VBW to: 10 kHz  
 Detector: peak  
 Sweep time: auto  
 Allow trace to fully stabilize. Then use the peak marker function to determine the maximum amplitude level.

#### Test Mode

Please refer to the clause 2.4.

#### Test Result

| Test Mode | Frequency[MHz] | Result[dBm/3kHz] | Limit[dBm/3kHz] | Verdict |
|-----------|----------------|------------------|-----------------|---------|
| BLE 1M    | 2402           | -16.55           | <=8             | PASS    |
|           | 2440           | -16.30           | <=8             | PASS    |
|           | 2480           | -16.54           | <=8             | PASS    |



Test plot as follows:

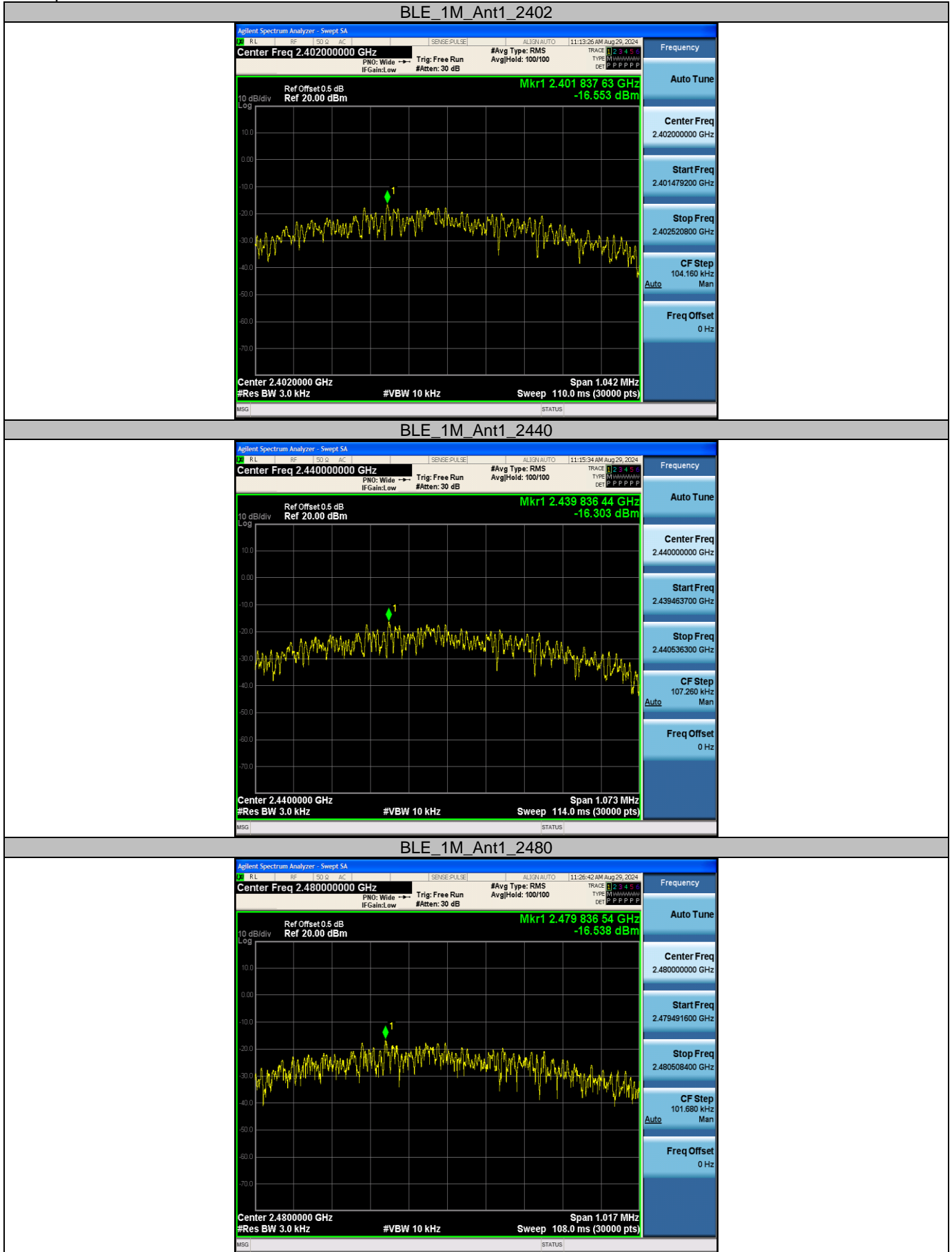

CTC Laboratories, Inc.

Room 101 Building B, No. 7, Lanqing 1st Road, Luhu Community, Guanhu Subdistrict, Longhua District, Shenzhen, Guangdong, China  
Tel.: (86)755-27521059 Fax: (86)755-27521011 Http://www.sz-ctc.org.cn



For anti-fake verification, please visit the official website of Certification and Accreditation Administration of the People's Republic of China : [yz.cnca.cn](http://yz.cnca.cn)

### 3.8. Duty Cycle

#### Limit

None, for report purposes only.

#### Test Configuration

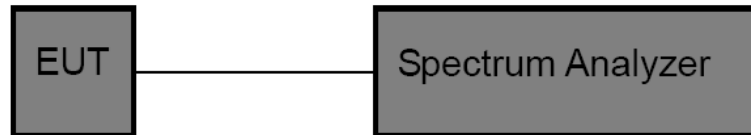

#### Test Procedure

1. The EUT was directly connected to the spectrum analyzer and antenna output port as show in the block diagram above.
2. The EUT was directly connected to the Spectrum Analyzer and antenna output port as show in the block diagram above. The measurement according to section 10.2 of KDB 558074 D01 DTS Meas Guidance v05r02.
3. Spectrum Setting:  
Set analyzer center frequency to test channel center frequency.  
Set the span to 0Hz  
Set the RBW to 8MHz  
Set the VBW to 8MHz  
Detector: Peak  
Sweep time: Auto  
Allow trace to fully stabilize. Then use the peak marker function to determine the maximum amplitude level.

#### Test Mode

Please refer to the clause 2.4.

#### Test Result

| Test Mode | Frequency [MHz] | Transmission Duration [ms] | Transmission Period [ms] | Duty Cycle [%] | 1/T Minimum VBW (kHz) | Final setting For VBW (kHz) |
|-----------|-----------------|----------------------------|--------------------------|----------------|-----------------------|-----------------------------|
| BLE 1M    | 2402            | 0.35                       | 0.62                     | 56.45          | 2.86                  | 3                           |
|           | 2440            | 0.35                       | 0.62                     | 56.45          | 2.86                  | 3                           |
|           | 2480            | 0.35                       | 0.62                     | 56.45          | 2.86                  | 3                           |



Test plot as follows:



CTC Laboratories, Inc.

Room 101 Building B, No. 7, Lanqing 1st Road, Luhu Community, Guanhu Subdistrict, Longhua District, Shenzhen, Guangdong, China  
 Tel.: (86)755-27521059 Fax: (86)755-27521011 Http://www.sz-ctc.org.cn



For anti-fake verification, please visit the official website of Certification and Accreditation Administration of the People's Republic of China : [yz.cnca.cn](http://yz.cnca.cn)



### 3.9. Antenna Requirement

#### Requirement

**FCC CFR Title 47 Part 15 Subpart C Section 15.203:**

An intentional radiator shall be designed to ensure that no antenna other than that furnished by the responsible party shall be used with the device. The use of a permanently attached antenna or of antenna that uses a unique coupling to the intentional radiator, the manufacturer may design the unit so that a broken antenna can be replaced by the user, but the use of a standard antenna jack or electrical connector is prohibited.

**FCC CFR Title 47 Part 15 Subpart C Section 15.247(c) (1)(i):**

(i) Systems operating in the 2400~2483.5 MHz band that is used exclusively for fixed. Point-to-point operations may employ transmitting antennas with directional gain greater than 6dBi provided the maximum conducted output power of the intentional radiator is reduced by 1 dB for every 3 dB that the directional gain of the antenna exceeds 6dBi.

#### Test Result

The directional gain of the antenna less than 6dBi, please refer to the EUT internal photographs antenna photo.

\*\*\*\*\*THE END\*\*\*\*\*