



GEM Dual Band Bluetooth and ANT+ Module
Hardware Integration Guide
Version 0.3
August 13, 2015



Wahoo Fitness

90 W. Wieuca Road N.E. Suite 110

Atlanta, GA 30342

Telephone: 1-877-978-1112

Email: support@wahoofitness.com

www.wahoofitness.com

© Wahoo Fitness LLC 2015

Revision History

Version	Revision Date	Change History
0.1	June 25, 2015	Initial Draft
0.2	July 20, 2015	Engineering edits
0.3	August 13, 2015	Added Tape and Reel info

Contents

REVISION HISTORY	2
CONTENTS	3
OVERVIEW AND KEY FEATURES	5
FEATURES	5
SPECIFICATION	6
SPECIFICATION SUMMARY – FITNESS MACHINE SOFTWARE	6
HARDWARE SPECIFICATIONS	7
BLOCK DIAGRAMS AND PINOUT	7
PIN DEFINITIONS	8
ELECTRICAL SPECIFICATIONS	9
DESIGN CONSIDERATIONS	9
HARDWARE	9
MODULE LAYOUT CONSIDERATIONS	11
GENERAL CONSIDERATIONS	11
ANTENNA CONSIDERATIONS	11
ANTENNA CHARACTERISTICS	11
ANTENNA KEEP OUT AREA	12
MECHANICAL INFORMATION	13
DIMENSIONS (IN MM)	13
RECOMMENDED PAD LAYOUT	13
SHIPPING AND PACKAGING INFORMATION	14
SOLDERING GUIDELINES	14
REGULATORY & STANDARDS INFORMATION	14
FCC & INDUSTRY CANADA	14
FEDERAL COMMUNICATION COMMISSION (FCC) RADIATION EXPOSURE STATEMENT:	15
FCC LABELING REQUIREMENTS	15
FCC WARNING:	16
INDUSTRY CANADA (IC) WARNING:	16
CE	18
BLUETOOTH QUALIFICATION	19

ORDERING DETAILS **19**

FURTHER ASSISTANCE **19**

Overview and Key Features

The GEM module has been designed to allow OEMs to easily add Bluetooth and ANT+ wireless connectivity in their product offering. The GEM module incorporates Wahoo Fitness software specifically designed to enable fitness machines such as treadmills, exercise bikes, ellipticals, rowers, stair climbers and step machines to wirelessly communicate exercise data with smart phone or tablets as well as leaderboard software systems. For applications other than fitness machines, developer's can use Nordic Semiconductor's SDK to create their own embedded application specific software.

The GEM module is based on Nordic Semiconductor's nRF51422 dual band Bluetooth and ANT+ chipset. The GEM module offers a variety of peripheral interfaces including UART, SPI, I2C, ADC, and GPIO, has a maximum transmit power of +4dBm, and a sensitivity of -93dBm. This manual is intended to assist hardware integration of the GEM module into a given design. Details on Wahoo's Fitness Machine software can be found in the GEM module Fitness Machine Software guide. For applications using Nordic Semiconductor SDK, please refer to Nordic Semiconductor's SDK available at developer.nordicsemi.com.

Features

- -90 dBm sensitivity in ANT mode
- -93 dBm sensitivity in *Bluetooth*® low energy mode
- TX Power-20 to +4dBm in 4dB steps
- 100m line of sight range
- 13 mA peak RX
- 9.7 mA peak RX
- 1 dB RSSI resolution
- ARM® Cortex™-M0 32 bit processor
- 256 kB embedded flash memory and 16 kB RAM
- Peripheral Interfaces: ADC, GPIO, SPI, I2C, UART, Low power comparator, Temperature sensor
- AES HW encryption
- FCC, CE, IC certified
- Integrated Antenna
- RoHS compliant
- Bluetooth End Product Listed
- Integrated Fitness Machine Firmware and mobile application

Specification

Specification Summary – Fitness Machine Software

Category	Feature	Implementation
RF	Bluetooth	4.1 Single Mode Peripheral
	ANT+	Broadcast
	Frequency	2.402-2.480 GHz
	Maximum Transmit Power	+4dBm
	Minimum Transmit Power	-20dBm
	Receive Sensitivity	-93dBm Bluetooth mode -91dBm Ant+ mode
	Range	up to 100m line of sight
Peripherals	UART Host Interface	TX, RX 9600bps n,8,1
	GPIO	Link Indicator Pairing Button
FW Upgrade	Wahoo Firmware	Over the air Via JTAG interface
Control Protocol	CSAFE	CSAFE Command Interface
Supply Voltage		1.8 – 3.6V
Power Consumption		TBD
Physical		12.7mm x 19.05mm
Environmental		-40 to +85C
Approvals		FCC, IC, CE, Bluetooth EPL

Hardware Specifications

Block Diagrams and Pinout

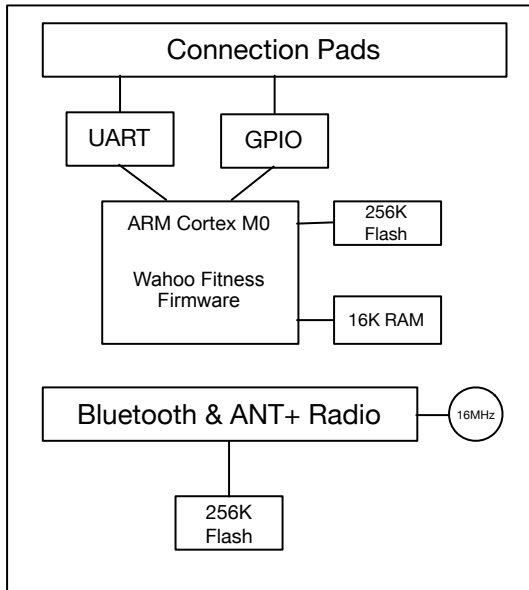

Hardware Block Diagram

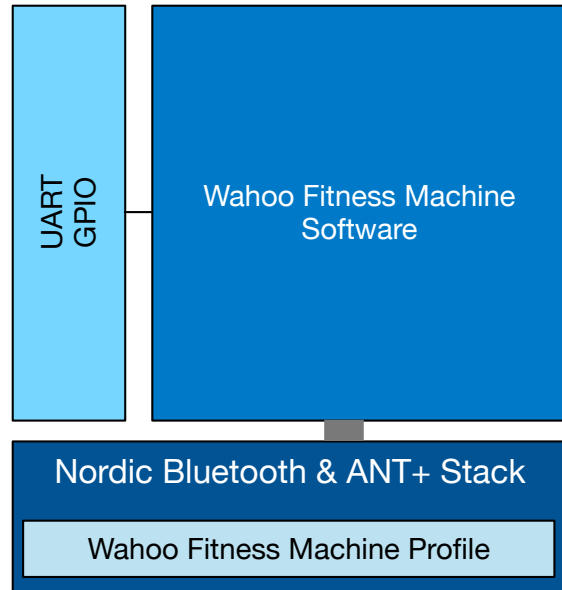

Software Diagram

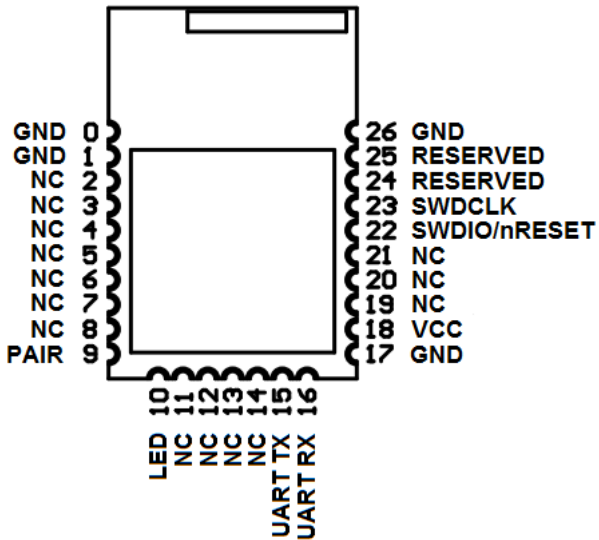

Pinout Diagram

Pin Definitions

Pin number	Pin Name	Function	Comment
0	GND		Connect to GND Plane
1	GND		Connect to GND Plane
2	NC		
3	NC		
4	NC		
5	NC		
6	NC		
7	NC		
8	NC		
9	PAIR	GPIO to trigger advertising	
10	LED	LED for Pairing/Connection	
11	NC		
12	NC		
13	NC		
14	NC		
15	TX	UART Transmit	CSAFE Host Interface
16	RX	UART Receive	CSAFE Host Interface
17	GND	Module Power Ground	
18	VCC	Module Power Supply	
19	NC		
20	NC		
21	NC		
22	RESET/SWDIO	Module Reset/Debug Interface	
23	SWCLK	Debug Interface	
24	NC		
25	NC		
26	GND		Connect to GND Plane

Electrical Specifications

Absolute Maximum ratings

Maximum and minimum ratings for digital and analog pins are listed below.

Parameter	Min	Max
VCC Voltage	-0.3V	+3.9V
Voltage at VIO	-0.3V	VCC+.3V
Storage Temperature	-40C	+85C

Recommended Operating Parameters

Parameter	Min	Typical	Max
VCC	1.8V	3.0V	+3.6V
VCC maximum ripple			10mV
VCC Rise time			100mS
Operating Temperature @ 3.3V	-40C		+85C

Design Considerations

The GEM module has been designed for easy integration into OEM applications requiring minimal additional componentry. The following section provides suggestions to ensure successful design in of the GEM module.

Hardware

VCC

Ensure the power source operating range and noise is within the specified limits for the GEM module and filter capacitors are incorporated as needed. The GEM module includes decoupling capacitors for circuits within the module. External circuits sharing the same power source should also be decoupled locally at connections to VCC and GND.

Updating Module Firmware

The GEM module firmware can be updated over the air using the Wahoo utility application. The Wahoo utility application can be downloaded here: www.xxxx.yyy.com

The GEM module firmware can also be updated through the Serial Wire Debug interface. The following circuit example provides a reference for developers wanting an alternative to programming the GEM module over the air:

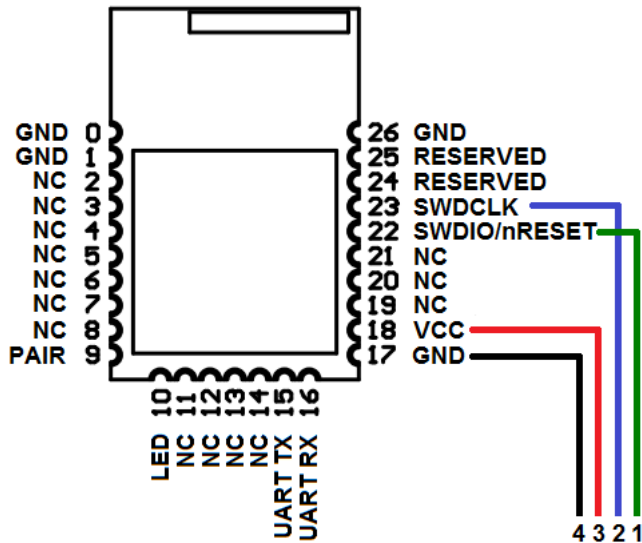

Example for Serial Wire Debug Interface

UART Host

The UART is required for communicating between the GEM module and fitness machine console using the CSAFE protocol. Pins 15 and 16 of the module have been configured as the UART interface. Pin 15 is the UART TX line and pin 16 is the UART RX line.

Reset

The GEM module can be reset by holding PIN 22 low for 0.5us. The following is an example reset circuit:

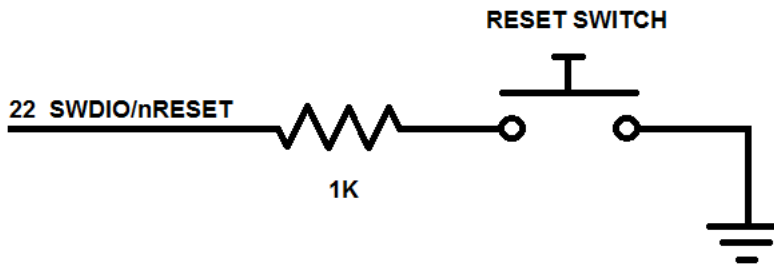

Example Reset Circuit

Module Layout Considerations

General Considerations

1. Locate the GEM Module close to the edge of your circuit board for best RF performance.
2. A solid ground plane should be used except for the antenna keep-out area.
3. All module GND pins must be connected to your circuit ground.
4. Place GND vias close to the module GND pads
5. Route traces to avoid noise being picked up on VCC or I/O lines
6. Ensure no exposed copper is located underneath the GEM module

Top-side area directly under the module should be kept clear of copper, silkscreen and vias

Antenna Considerations

The GEM antenna was characterized using the GEM development board. Similar performance can be obtained by following the following layout guidelines:

1. Locate the GEMSRB01 on the edge of the host PCB in the right corner to allow the antenna to radiate properly.
2. Keep all mounting hardware and metal clear of the keep out area for proper antenna radiation.
3. Metal close to the GEMSRB01 antenna will have degradation on the antenna performance. Suggested clearances are 20mm top/bottom and 20mm left or right.
4. It is best that the customer test with an actual prototype or final design to see the effects of any enclosure.
5. The antenna keep-out area and dimensions are shown in the figure below.

Antenna Characteristics

The GEM module includes an integrated monopole chip antenna. Antenna performance will depend on host PCB layout. The following plots show antenna radiation pattern of the GEM antenna.

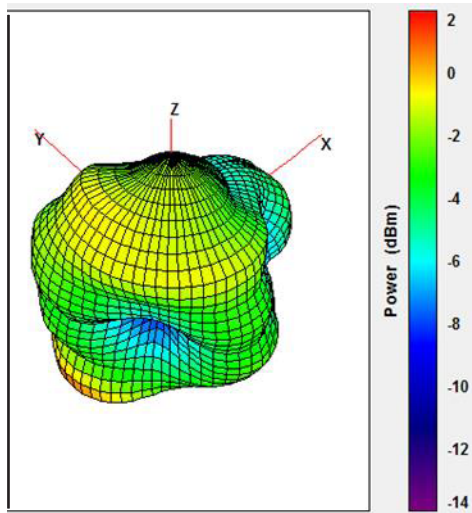

Antenna Radiation Plot

	Efficiency	Peak Gain	Directivity
2400MHz	61.13%	3.39 dBi	5.53 dBi
2450MHz	66.79%	3.45 dBi	5.20 dBi
2500MHz	57.65%	2.75 dBi	5.14 dBi

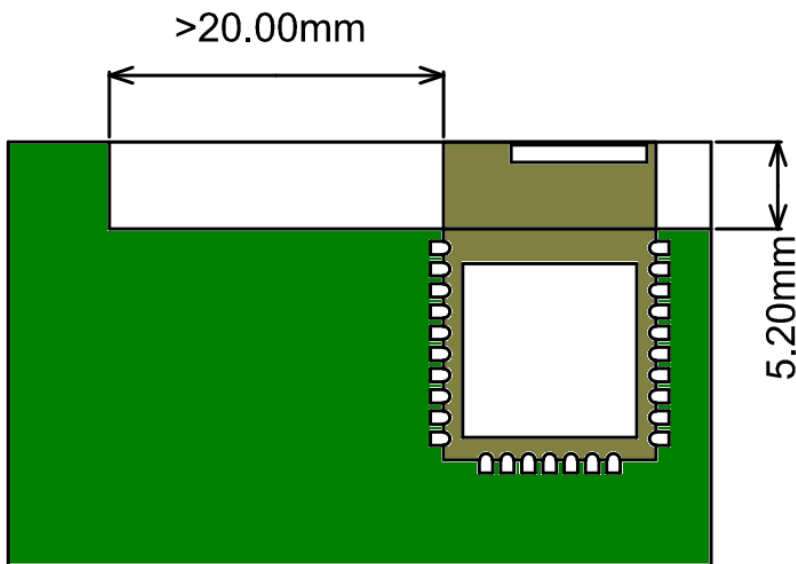

Antenna Keep out Area

Mechanical Information

Dimensions (in mm)

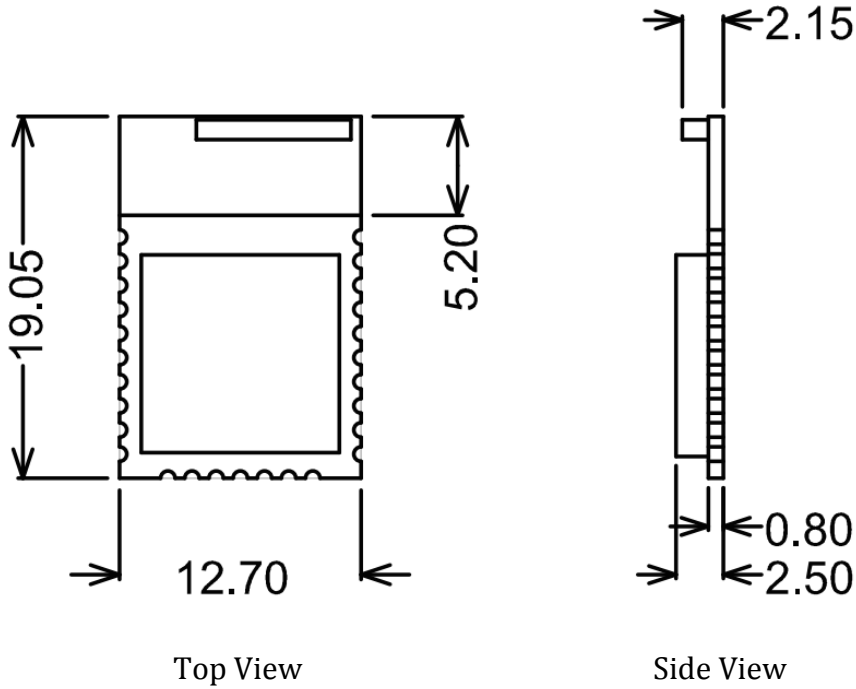

Recommended Pad Layout

The land pattern dimensions can be modified based on experience.

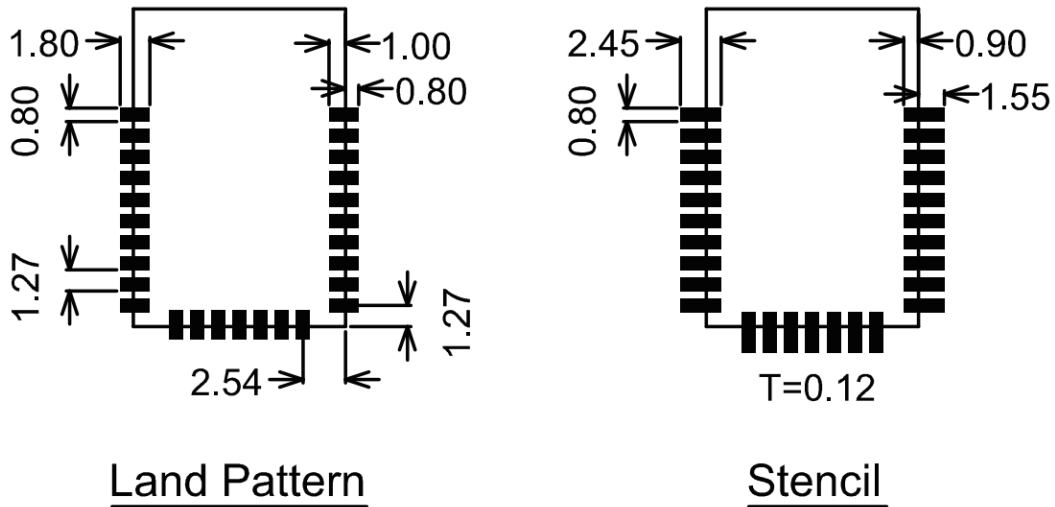

Tape and Reel Information

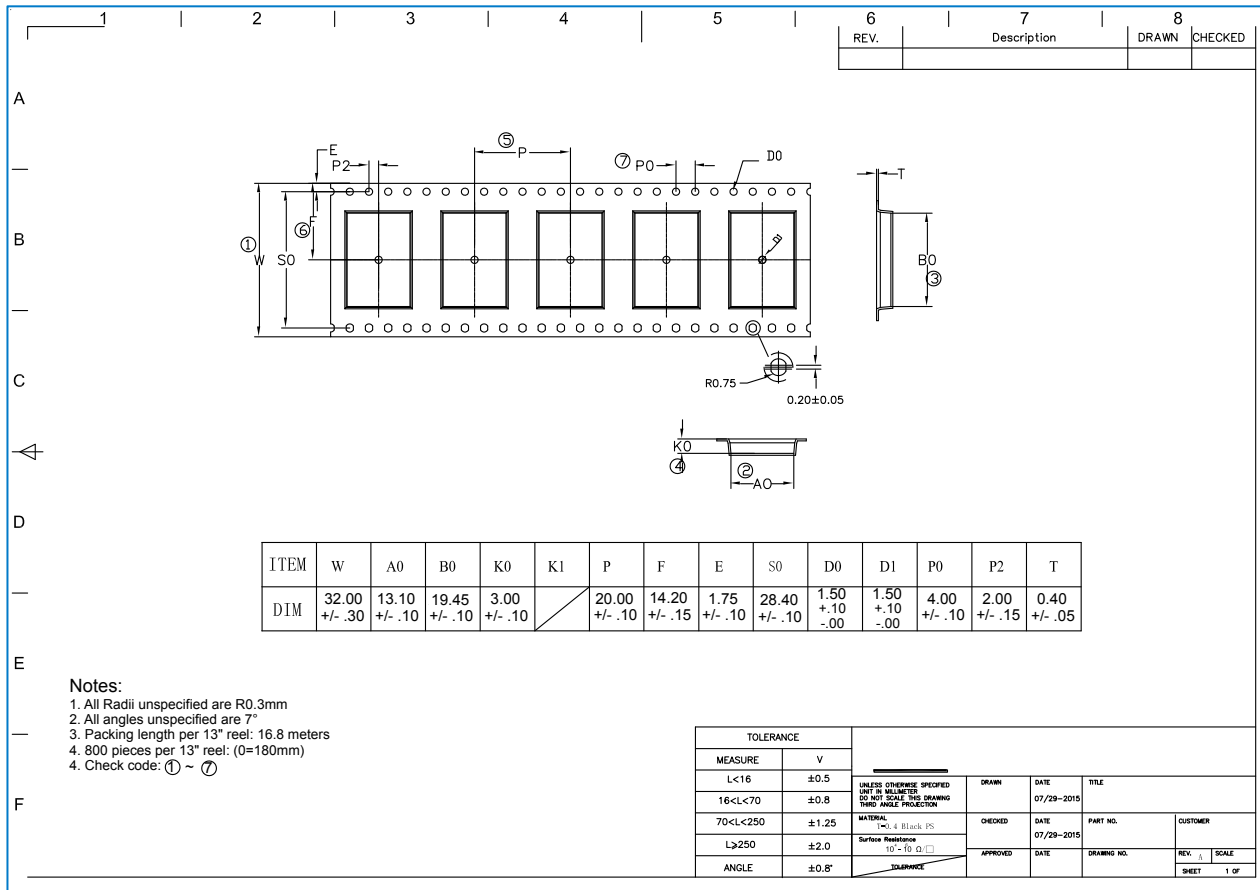

Soldering Guidelines

See the Stencil pattern above for solder paste application. Recommended Stencil thickness is 120um.

Regulatory & Standards Information

FCC & Industry Canada

The GEM module has modular approval for the United States and Canada. To ensure compliance when using the GEM module in a design, the OEM is required to adhere to the implementation considerations supplied in this hardware integration guide.

Federal Communication Commission (FCC) Radiation Exposure Statement:

This device is in compliance with SAR for general population/uncontrolled exposure limits in ANSI/IEEE C95.1-1999 and had been tested in accordance with the measurement methods and procedures specified in OET Bulletin 65 Supplement C.

This transceiver must not be co-located or operating in conjunction with any other antenna, transmitter, or external amplifiers. Further testing / evaluation of the end product will be required if the OEM's device violates any of these requirements.

The user manual for end users must include the following information in a prominent location "IMPORTANT NOTE: To comply with FCC RF exposure compliance requirements, the antenna used for this transmitter must be installed to provide a separation distance of at least 0.5 cm from all persons and must not be colocated or operating in conjunction with any other antenna or transmitter

The GEM Module is fully approved for mobile and portable applications.

FCC Labeling Requirements

WARNING: The OEM must ensure that FCC labeling requirements are met. This includes a clearly visible label on the outside of the OEM enclosure specifying the appropriate FCC identifier is visible.

Contains FCC ID: PADWF111
 IC: 10563A-WF111

If OEM device is larger than 8x10cm, the following FCC part 15.19 statement has to be visible on outside of device:

The enclosed device complies with Part 15 of the FCC Rules. Operation is subject to the following two conditions: (1) This device may not cause harmful interference, and (2) This device must accept any interference received, including interference that may cause undesired operation.

Label and text information type should be large enough to be legible and consistent with the dimensions of the equipment and the label. The type size is not required to be larger than eight points.

Comments

The OEM should have their device tested by a qualified test house to verify compliance with FCC Part 15 Subpart B limits for unintentional radiators.

Any modifications to the GEM module could void the OEM's authority to operate the equipment.

This equipment has been tested and found to comply with the limits for a Class B digital device, pursuant to Part 15 of the FCC Rules. These limits are designed to provide reasonable protection against harmful interference in a residential installation. This equipment generates, uses, and can radiate radio frequency energy and, if not installed and used in accordance with the instructions, may cause harmful interference to radio communications. However, there is no guarantee that interference will not occur in a

particular installation. If this equipment does not cause harmful interference to radio or television reception, which can be determined by turning the equipment off and on, the user is encouraged to correct the interference by one or more of the following measures:

- Re-orient or relocate the receiving antenna
- Increase the separation between the equipment and the receiver
- Connect the equipment to an outlet on a circuit that is different from that to which the receiver is connected.
- Consult the dealer or an experienced radio/TV technician for help.

FCC Warning:

“THIS DEVICE COMPLIES WITH PART 15 OF THE FCC RULES AND INDUSTRY CANADA LICENSE-EXEMPT RSS STANDARD(S). OPERATION IS SUBJECT TO THE FOLLOWING TWO CONDITIONS: (1) THIS DEVICE MAY NOT CAUSE HARMFUL INTERFERENCE, AND (2) THIS DEVICE MUST ACCEPT ANY INTERFERENCE RECEIVED, INCLUDING INTERFERENCE THAT MAY CAUSE UNDESIRE OPERATION.

Industry Canada (IC) Warning:

This device complies with Industry Canada license-exempt RSS standard(s). Operation is subject to the following two conditions: (1) this device may not cause interference, and (2) this device must accept any interference, including interference that may cause undesired operation of the device.

French equivalent:

Le présent appareil est conforme aux CNR d'Industrie Canada applicable aux appareils radio exempts de licence. L'exploitation est autorisée aux deux conditions suivantes : (1) l'appareil ne doit pas produire de brouillage, et (2) l'utilisateur de l'appareil doit accepter tout brouillage radioélectrique subi, même si le brouillage est susceptible d'en compromettre le fonctionnement.

IC Radiation Exposure Statement

This device is in compliance with SAR for general population/uncontrolled exposure limits in IC RSS-102 and had been tested in accordance with the measurement methods and procedures specified in IEEE 1528. This equipment should be installed and operated with minimum distance 0.5 cm between the radiator and your body.

REMARQUE IMPORTANTE

Déclaration IC d'exposition aux radiations Ce EUT est conforme avec SAR pour la population générale / limites d'exposition non contrôlée à IC RSS-102 et a été testé en conformité avec les méthodes de mesure et procédures spécifiées dans la norme IEEE 1528.

Modular Approval

OEM is still responsible for testing their product for any additional compliance requirements required with this module installed (for example, digital device emissions, PC peripheral requirements, etc.).

Approbation modulaire

OEM intégrateur est toujours responsable de tester leur produit final pour les exigences de conformité supplémentaires nécessaires à ce module installé (par exemple, les émissions de périphériques numériques, les exigences de périphériques PC, etc.)

IMPORTANT NOTE:

In the event that these conditions cannot be met (for example certain laptop configurations or co-location with another transmitter), then the Canada authorization is no longer considered valid and the IC ID cannot be used on the final product. In these circumstances, the OEM integrator will be responsible for re-evaluating the end product (including the transmitter) and obtaining a separate Canadian authorization.

NOTE IMPORTANTE:

Dans le cas où ces conditions ne peuvent être satisfaites (par exemple pour certaines configurations d'ordinateur portable ou de certaines co-localisation avec un autre émetteur), l'autorisation du Canada n'est plus considéré comme valide et l'ID IC ne peut pas être utilisé sur le produit final. Dans ces circonstances, l'intégrateur OEM sera chargé de réévaluer le produit final (y compris l'émetteur) et l'obtention d'une autorisation distincte au Canada.

Le produit final doit être étiqueté dans un endroit visible avec l'inscription suivante: " GEM Module Contient des IC: 10563A-WF111"

CE

The GEM Module has been tested against the appropriate regulatory standards for European market. OEMs should consult a qualified test house to ensure their product meets all regulatory requirements.

The GEM Module Declaration of Conformities is below. Test reports are available upon request.

Health and Safety – EN 62479 (2010) and EN 60950-1:2006+A11:2009+A1:2010+A12:2011+A2:2013

Electromagnetic compatibility – EN 301 489-1 : V1.9.2 (2011) and EN 301 489-17: V2.2.1 (2012)

Radio Frequency Radiated Emissions: EN300 328 V1.8.1

Wahoo Fitness declares under our sole responsibility that the essential radio tests have been carried out and that the GEM Module to which this declaration relates is in conformity with all applicable essential requirements of Article 3 of the EU Directive 1999/5/EC when used for its intended purpose.

Place of Issue: Wahoo Fitness LLC
 90 W. Wieuca Road Suite 110
 Atlanta, GA 30342
 +1(877) 978-1112

Date: July, 2015
Authorized Person: James Halter
Signature:

Bluetooth Qualification

The GEM module has been listed with the Bluetooth Special Interest Group (SIG) as a qualified an End Product. The Wahoo Fitness Declaration ID is: D027620

The Bluetooth SIG requires every product implementing Bluetooth technology to have a Declaration ID even though the end product references a Bluetooth design with its own Declaration ID.

An over of the Bluetooth SIG Qualification Process is as follows:

1. Register as a member of the Bluetooth SIG – www.bluetooth.org
2. Go to product listing page <https://www.bluetooth.org/en-us/test-qualification/qualification-overview>
3. Go to Create a Listing: https://www.bluetooth.org/tpg/QLI_SDoc.cfm
4. In the area “Reference a Qualified Design, Enter End Product ID: xxxxxxxx
5. Select your Declaration ID or Purchase a Declaration ID. Fees for Declaration IDs vary based on Bluetooth SIG membership level.
6. Once you have completed your listing and paid your declaration fee, your design will be listed on the Blueooth SIG website.

You can find more details on the Bluetooth SIG listing process at the following webpage: <https://www.bluetooth.org/en-us/test-qualification/qualification-overview>

Ordering Details

Part Number	Reel Size	Shipping Weight	MOQ	Multiple
GEMSRB01	800 pieces	TBD	800	800

Further Assistance

Please contact Wahoo Fitness at 1-877-978-1112 or via email at info@wahoofitness.com if additional help is needed.