

FCC PART 15C TEST REPORT FOR CERTIFICATION  
On Behalf of

Phottix (HK) Ltd.

Phottix Aion Wireless Timer Remote Transmitter

Model No. : Aion

FCC ID: P9M-AIONTX

Prepared for : Phottix (HK) Ltd.

10/F Block A, Yip Fat Factory Building, Phasel, 77 Hoi Yuen  
Rd, Kwun Tong, Kln, Hong Kong

Prepared By : Audix Technology (Shenzhen) Co., Ltd.

No. 6, Ke Feng Rd., 52 Block,  
Shenzhen Science & Industrial Park,  
Nantou, Shenzhen, Guangdong, China

Tel: (0755) 26639496

Report Number : ACS-F13094

Date of Test : Apr.04~05, 2013

Date of Report : Apr.24, 2013

## TABLE OF CONTENTS

<u>Description</u>	<u>Page</u>
<b>1. SUMMARY OF STANDARDS AND RESULTS .....</b>	<b>1-4</b>
1.1. Description of Standards and Results .....	1-4
<b>2. GENERAL INFORMATION .....</b>	<b>2-1</b>
2.1. Description of Device (EUT) .....	2-1
2.2. Block Diagram of Test Setup .....	2-1
2.3. Test Facility .....	2-2
2.4. Measurement Uncertainty (95% confidence levels, k=2).....	2-2
<b>3. POWER LINE CONDUCTED EMISSION TEST.....</b>	<b>3-1</b>
<b>4. RADIATED EMISSION TEST .....</b>	<b>4-1</b>
4.1. Test Equipment.....	4-1
4.2. Block Diagram of Test Setup .....	4-2
4.3. Radiated Emission Limit .....	4-3
4.4. EUT Configuration on Test .....	4-3
4.5. Operating Condition of EUT .....	4-3
4.6. Test Procedure .....	4-3
4.7. Radiated Emission Test Results .....	4-4
<b>5. BAND EDGE COMPLIANCE TEST .....</b>	<b>5-1</b>
5.1. Test Equipment.....	5-1
5.2. Limit .....	5-1
5.3. Test Produce .....	5-1
<b>6. 20 DB BANDWIDTH TEST .....</b>	<b>6-1</b>
6.1. Test Equipment.....	6-1
6.2. Limit .....	6-1
6.3. Test Results .....	6-1
<b>7. DEVIATION TO TEST SPECIFICATIONS .....</b>	<b>7-1</b>
<b>8. PHOTOGRAPH OF TEST.....</b>	<b>8-1</b>
8.1. Photos of Radiated Emission Test .....	8-1
<b>9. PHOTOS OF THE EUT .....</b>	<b>9-1</b>

### TEST REPORT CERTIFICATION

Applicant : Phottix (HK) Ltd.  
 Manufacturer : Phottix (HK) Ltd.  
 EUT Description : Phottix Aion Wireless Timer Remote Receiver  
 FCC ID : P9M-AIONRX  
 (A) MODEL NO. : Aion  
 (B) SERIAL NO. : N/A  
 (C) Power Supply : DC 3V  
 (D) TEST VOLTAGE : DC 3V

Tested for comply with:  
 FCC Rules and Regulations Part 15 Subpart C: 2011

Test procedure used:  
 ANSI C63.10:2009

The device described above is tested by AUDIX TECHNOLOGY (SHENZHEN) CO., LTD. to confirm comply with all the FCC Part 15 Subpart C requirements. The test results are contained in this test report and AUDIX TECHNOLOGY (SHENZHEN) CO., LTD. is assumed full responsibility for the accuracy and completeness of these tests. Also, this report shows that the Equipment Under Test (EUT) is to be technically compliant with the FCC and IC requirements. This report contains data that are not covered by the NVLAP accreditation.

This Report is made under FCC Part 2.1075. No modifications were required during testing to bring this product into compliance.

This report applies to above tested sample only. This report shall not be reproduced in part without written approval of AUDIX TECHNOLOGY (SHENZHEN) CO., LTD.

The report must not be used by the client to claim product certification, approval, or endorsement by NVLAP, NIST, or any agency of the federal government.

Date of Test : Apr.04~05, 2013 Report of date: Apr.24, 2013

Prepared by : Lisa Liang / Assistant  
 Reviewed by : Sunny Lu / Assistant Manager



Approved & Authorized Signer : Ken Lu / Manager

## 1. SUMMARY OF STANDARDS AND RESULTS

### 1.1. Description of Standards and Results

The EUT have been tested according to the applicable standards as referenced below.

EMISSION		
Description of Test Item	Standard	Results
Power Line Conducted Emission Test	FCC Part 15C: 15.207 ANSI C63.10-2009	PASS
Radiated Emission Test	FCC Part 15C: 15.209 FCC Part 15C: 15.249 ANSI C63.10-2009	PASS
Band Edge Compliance Test	FCC Part 15: 15.249 ANSI C63.10-2009	PASS
20% Bandwidth Test	FCC Part 15: 15.215 ANSI C63.10-2009	PASS

## 2. GENERAL INFORMATION

### 2.1. Description of Device (EUT)

Product Name	: Phottix Aion Wireless Timer Remote Transmitter
Model Number	: Aion
FCC ID	: P9M-AIONTX
Operation Frequency	: 2432MHz-2439MHz
Modulation Technology	: GFSK
Antenna Assembly Gain	: Integrated PCB antenna, 0dBi gain
Power Supply	: DC 3V
Applicant	: Phottix (HK) Ltd. 10/F Block A, Yip Fat Factory Building, Phasel, 77 Hoi Yuen Rd, Kwun Tong, Kln, Hong Kong
Manufacturer	: Phottix (HK) Ltd. 10/F Block A, Yip Fat Factory Building, Phasel, 77 Hoi Yuen Rd, Kwun Tong, Kln, Hong Kong
Date of Test	: Apr.04~05, 2013
Date of Receipt	: Apr.03, 2013
Sample Type	: Prototype production

### 2.2. Block Diagram of Test Setup

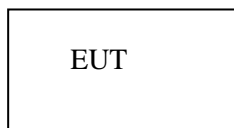

( EUT: Phottix Aion Wireless Timer Remote Transmitter)

### 2.3. Test Facility

#### Site Description

Name of Firm : Audix Technology (Shenzhen) Co., Ltd.  
 No. 6, Ke Feng Rd., 52 Block, Shenzhen  
 Science & Industrial Park, Nantou,  
 Shenzhen, Guangdong, China

3m Anechoic Chamber : Certificated by FCC, USA  
 Registration Number: 90454  
 Valid Date: Feb.22, 2015

3m & 10m Anechoic Chamber : Certificated by FCC, USA  
 Registration Number: 794232  
 Valid Date: Oct.31, 2015

EMC Lab. : Certificated by Industry Canada  
 Registration Number: IC 5183A-1  
 Valid Date: Jun.13, 2014

: Certificated by DAkkS, Germany  
 Registration No: D-PL-12151-01-01  
 Valid Date: Feb.01, 2014

Accredited by NVLAP, USA  
 NVLAP Code: 200372-0  
 Valid Date: Mar.31, 2014

### 2.4. Measurement Uncertainty (95% confidence levels, k=2)

Test Item	Uncertainty
Uncertainty for Radiation Emission test in 3m chamber	3.6 dB(30~200MHz, Polarize: H)
	3.8 dB(30~200MHz, Polarize: V)
	4.2 dB(200M~1GHz, Polarize: H)
	3.8 dB(200M~1GHz, Polarize: V)
Uncertainty for Radiation Emission test in 3m chamber (1GHz-18GHz)	3.1dB (Distance: 3m Polarize: V)
	3.7 dB (Distance: 3m Polarize: H)
Uncertainty for Radiated Spurious Emission test in RF chamber	3.57 dB
Uncertainty for Conduction Spurious emission test	2.00 dB
Uncertainty for Output power test	0.73 dB
Uncertainty for Power density test	2.00 dB
Uncertainty for Frequency range test	$7 \times 10^{-8}$
Uncertainty for Bandwidth test	83 kHz
Uncertainty for DC power test	0.038 %
Uncertainty for test site temperature and humidity	0.6°C
	3%

### **3. POWER LINE CONDUCTED EMISSION TEST**

According to Paragraph (c) of FCC Part 15 section 15.249, Tests to demonstrate compliance with the conducted limits are not required for devices which only employ battery power for operation and which do not operate from the AC power lines or contain provisions for operation while connected to the AC power lines.

## 4. RADIATED EMISSION TEST

### 4.1. Test Equipment

#### 4.1.1. For frequency range 30MHz~1000MHz (At Anechoic Chamber)

Item	Equipment	Manufacturer	Model No.	Serial No.	Last Cal.	Cal. Interval
1	3#Chamber	AUDIX	N/A	N/A	Nov.24,12	1 Year
2	EMI Spectrum	Agilent	E4407B	MY41440292	May.08, 12	1 Year
3	Test Receiver	Rohde & Schwarz	ESVS10	834468/011	May.08, 12	1 Year
4	Amplifier	HP	8447D	2648A04738	May.08, 12	1 Year
5	Trilog-Broadband Antenna	SCHWARZBECK	VULB 9168	9168-429	Nov.27, 12	1.0 Year
6	RF Cable	MIYAZAKI	CFD400-N L	3# Chamber No.1	May.08, 12	1 Year
7	Coaxial Switch	Anritsu	MP59B	M74389	May.08, 12	1 Year

#### 4.1.2. For frequency range 1GHz~25GHz (At Anechoic Chamber)

Item	Equipment	Manufacturer	Model No.	Serial No.	Last Cal.	Cal. Interval
1	Spectrum Analyzer	Agilent	E4407B	MY41440292	May.08, 12	1 Year
2	Horn Antenna	EMCO	3115	9510-4580	June.05, 12	1 Year
3	Amplifier	Agilent	8449B	3008A00863	May.08, 12	1 Year
4	RF Cable	Hubersuhner	SUCOFLEX106	77980/6	May.08, 12	1 Year
5	RF Cable	Hubersuhner	SUCOFLEX106	77977/6	May.08, 12	1 Year
6	Horn Antenna	EMCO	3116	00060089	Nov.25,11	1.5 Year



### 4.2. Block Diagram of Test Setup

For frequency range 30MHz-1000MHz

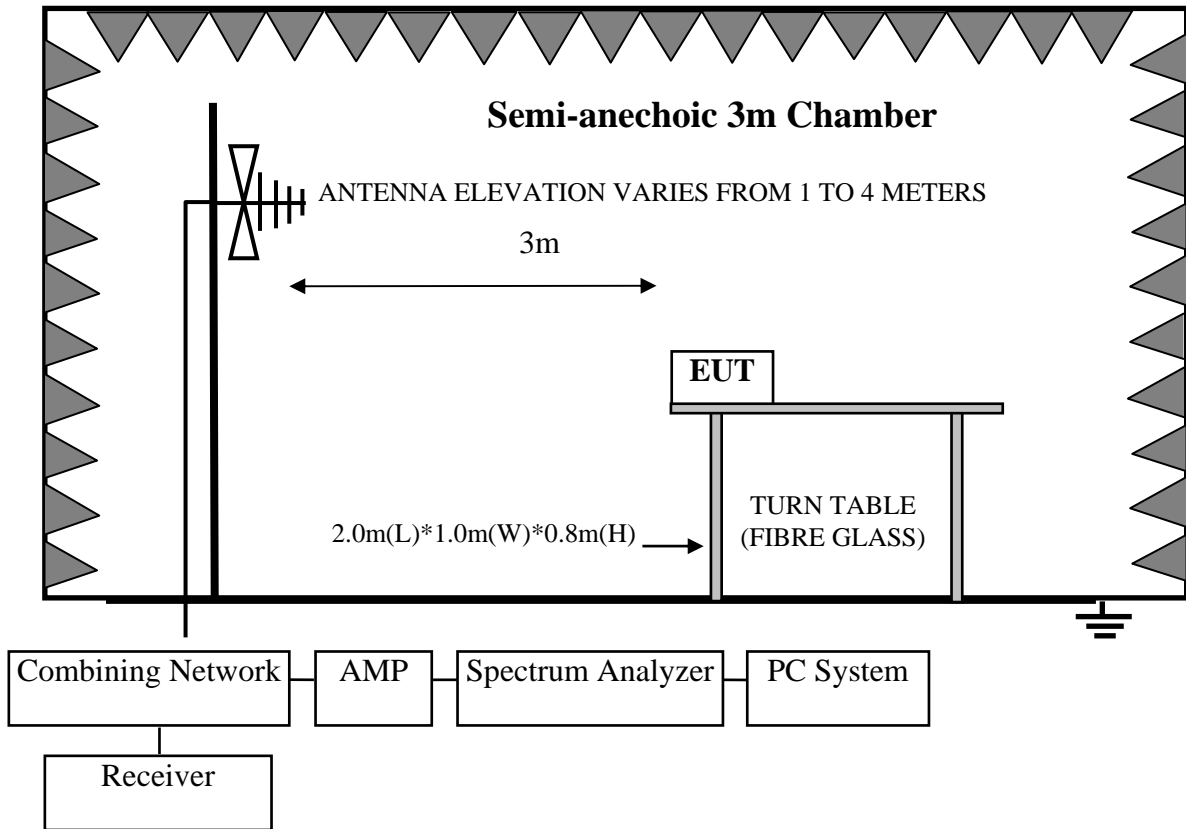

For frequency range 1GHz-25GHz

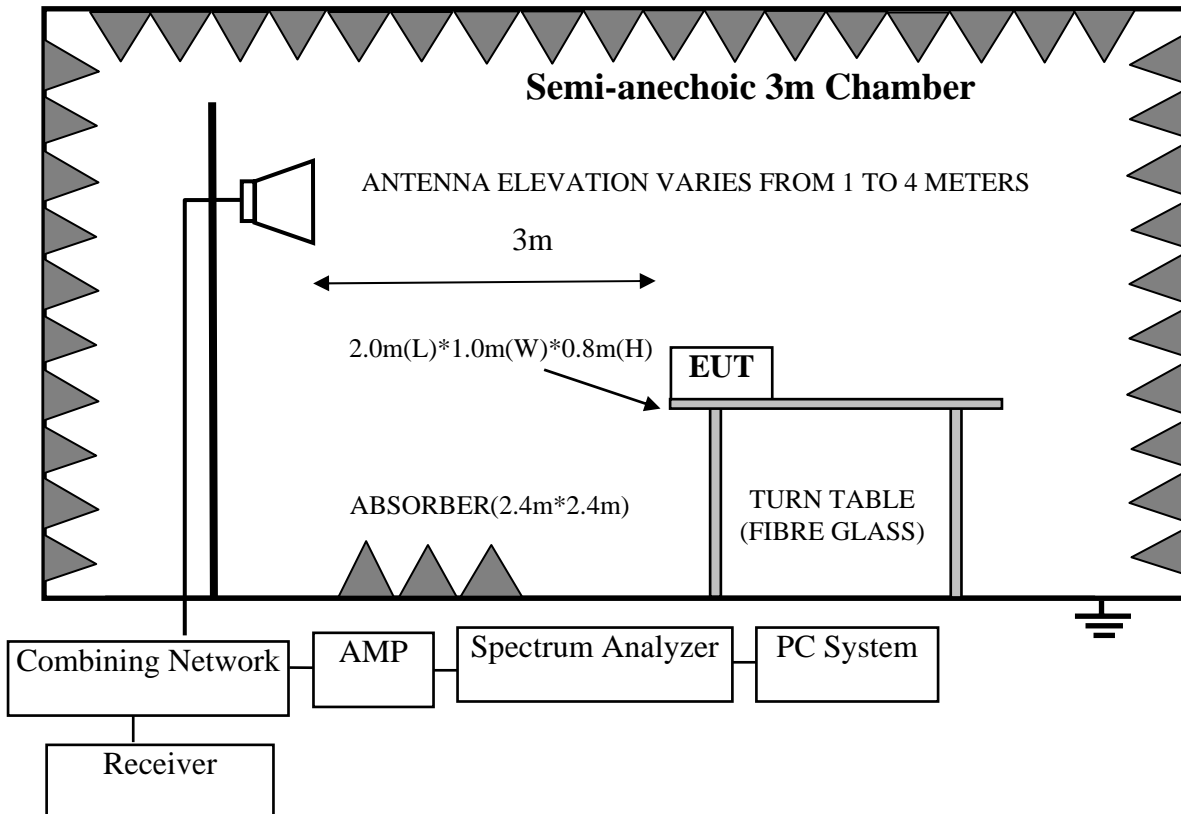

### 4.3.Radiated Emission Limit

#### 4.3.1.FCC 15.209 and 15.249

FREQUENCY MHz	DISTANCE Meters	FIELD STRENGTHS LIMIT	
		μV/m	dB(μV)/m
30 ~ 88	3	100	40.0
88 ~ 216	3	150	43.5
216 ~ 960	3	200	46.0
960 ~ 1000	3	500	54.0
Above 1000MHz	3	74.0 dB(μV)/m (Peak) 54.0 dB(μV)/m (Average)	
Field Strength of fundamental emissions for 2.4GHz-2.4835GHz	3	114.0 dB(μV)/m (Peak) 94.0 dB(μV)/m (Average)	

Remark : (1) Emission level  $\text{dB}\mu\text{V} = 20 \log \text{Emission level } \mu\text{V}/\text{m}$

- (2) The smaller limit shall apply at the cross point between two frequency bands.
- (3) Distance is the distance in meters between the measuring instrument, antenna and the closest point of any part of the device or system.
- (4) The emission limits shown in the above table are based on measurements employing a CISPR quasi-peak detector except for the frequency bands 9-90 kHz, 110-490 kHz and above 1000 MHz. Radiated emission limits in these three bands are based on measurements employing an average detector.

### 4.4.EUT Configuration on Test

The following equipment are installed on Radiated Emission Test to meet the commission requirements and operating regulations in a manner which tends to maximize its emission characteristics in normal application.

### 4.5.Operating Condition of EUT

- 4.5.1. Setup the EUT and simulator as shown as Section 4.2.
- 4.5.2. Turned on the power of all equipment.
- 4.5.3. Let EUT work in Tx mode.

### 4.6. Test Procedure

The EUT and its simulators are placed on a turn table, which is 0.8 meter high above ground. The turn table can rotate 360 degrees to determine the position of the maximum emission level. The EUT is set 3 meters away from the receiving antenna, which is mounted on a antenna tower. The antenna can be moved up and down between 1 meter and 4 meters to find out the maximum emission level. Broadband antenna (calibrated bilog antenna) is used as receiving antenna. Both horizontal and vertical polarization of the antenna is set on Test. In order to find the maximum emission levels, all of the interface cables must be manipulated according to ANSI C63.10-2009 on radiated emission Test.

The bandwidth of the EMI test receiver (R&S ESVS10) is set at 120kHz for frequency range from 30MHz to 1000 MHz.

The bandwidth of the Spectrum's RBW is set at 1MHz and VBW is set at 3MHz for peak emissions measurement above 1GHz

This device is pulse modulated, a duty cycle factor was used to calculate average level based measured peak level.

This test was performed with EUT in X, Y, Z position, and the worse case was found when EUT in X position as test photo indicated.

The frequency range from 30MHz to 10th harmonic (25GHz) are checked, and no any emission were found from 18 GHz to 25GHz, so the radiated emission from 18GHz-25GHz were not record.

#### 4.7. Radiated Emission Test Results

**PASS.**

All the emissions from 30MHz to 25GHz were comply with the 15.209 Limit.

Note: The duty cycle factor for calculate average level is 27.8dB, and average limit is 20dB below peak limit, so if peak measured level comply with peak limit, the average level was deemed to comply with average limit.

Duty cycle:  $0.37\text{ms} / 9.067\text{ms} * 100\% = 4.08\%$

Duty cycle factor =  $20\log(1/\text{duty cycle}) = 27.8\text{dB}$

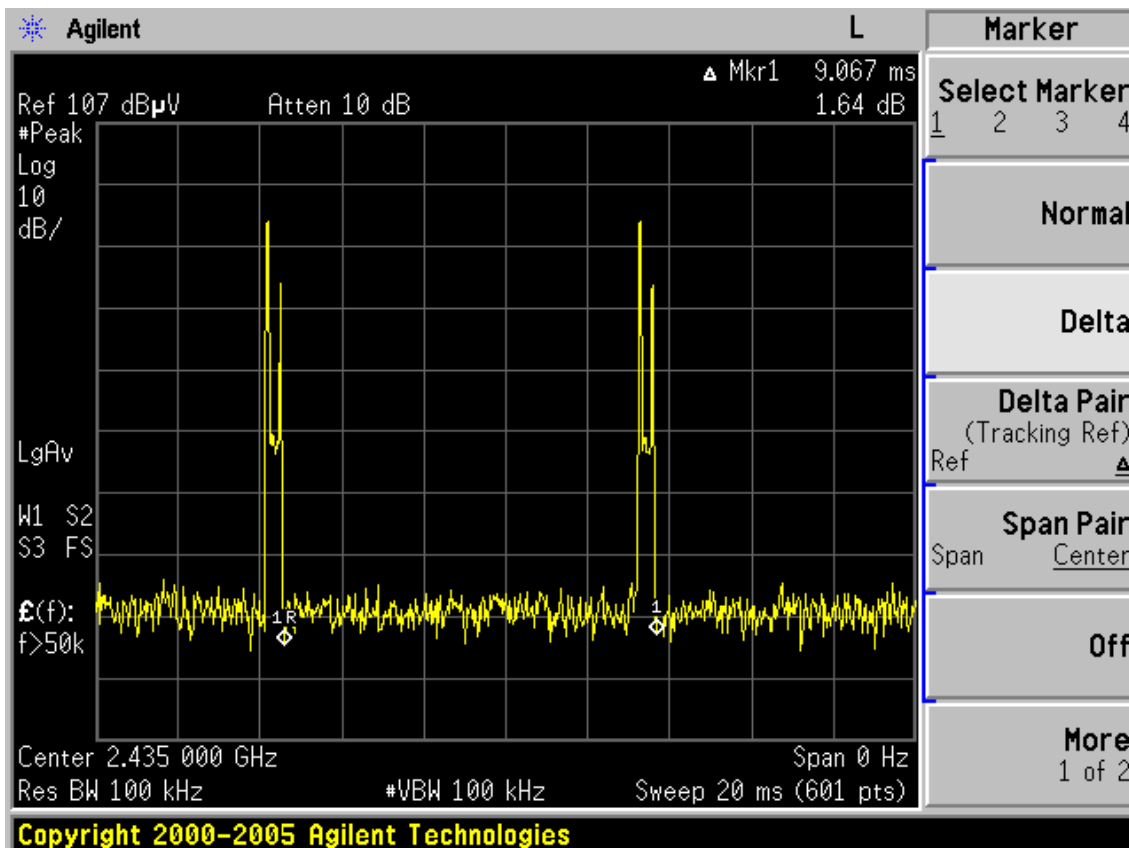
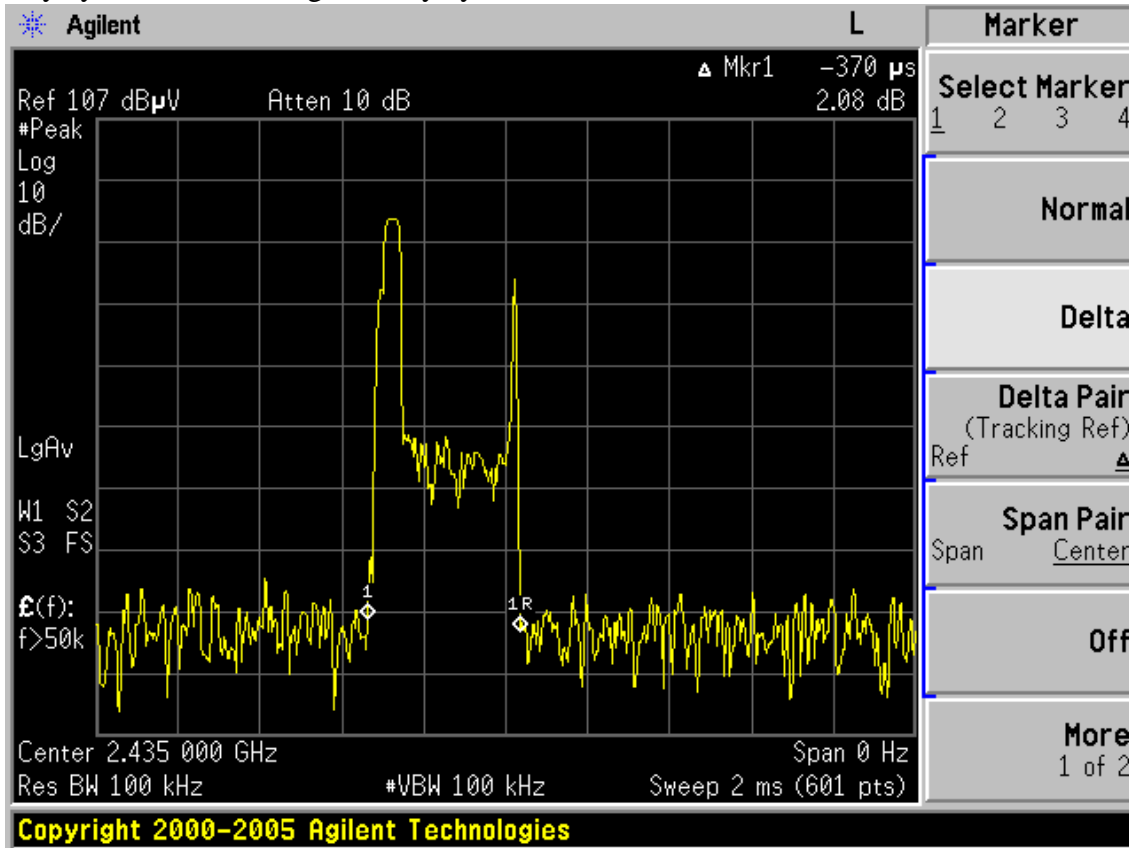

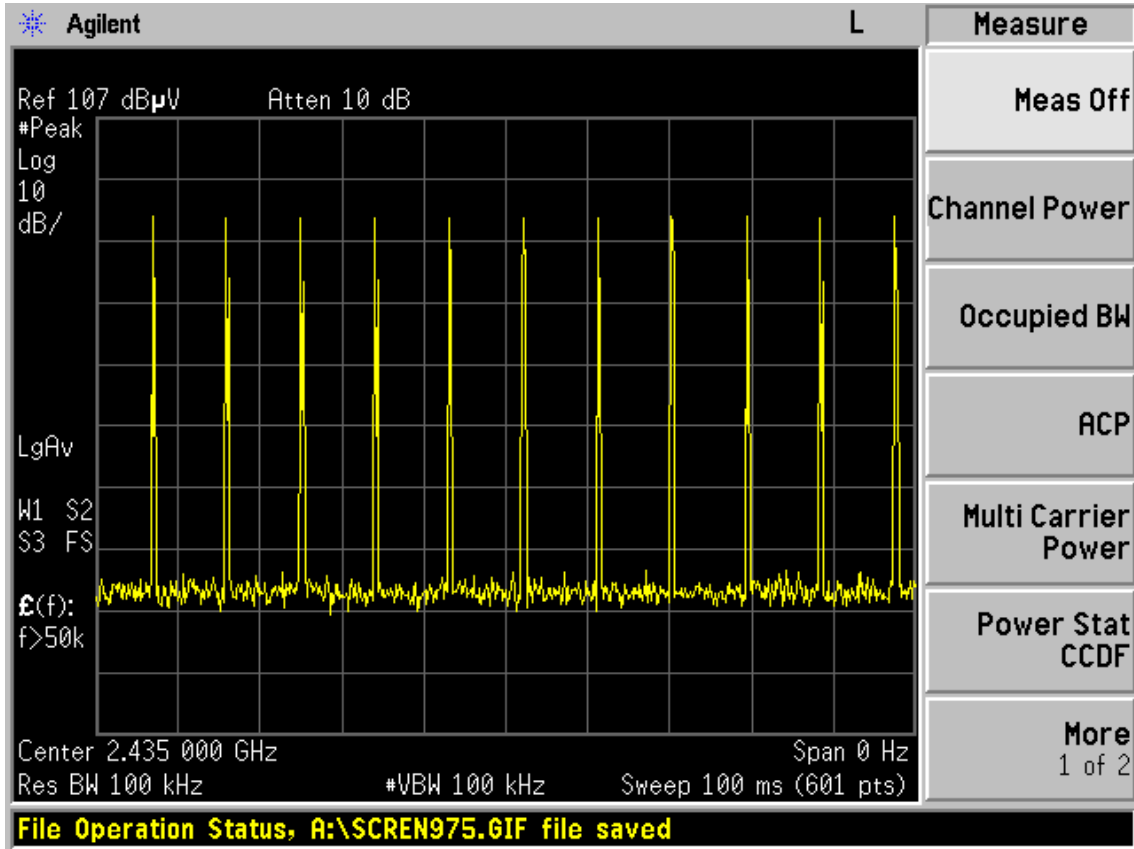

Frequency: 30MHz~1GHz

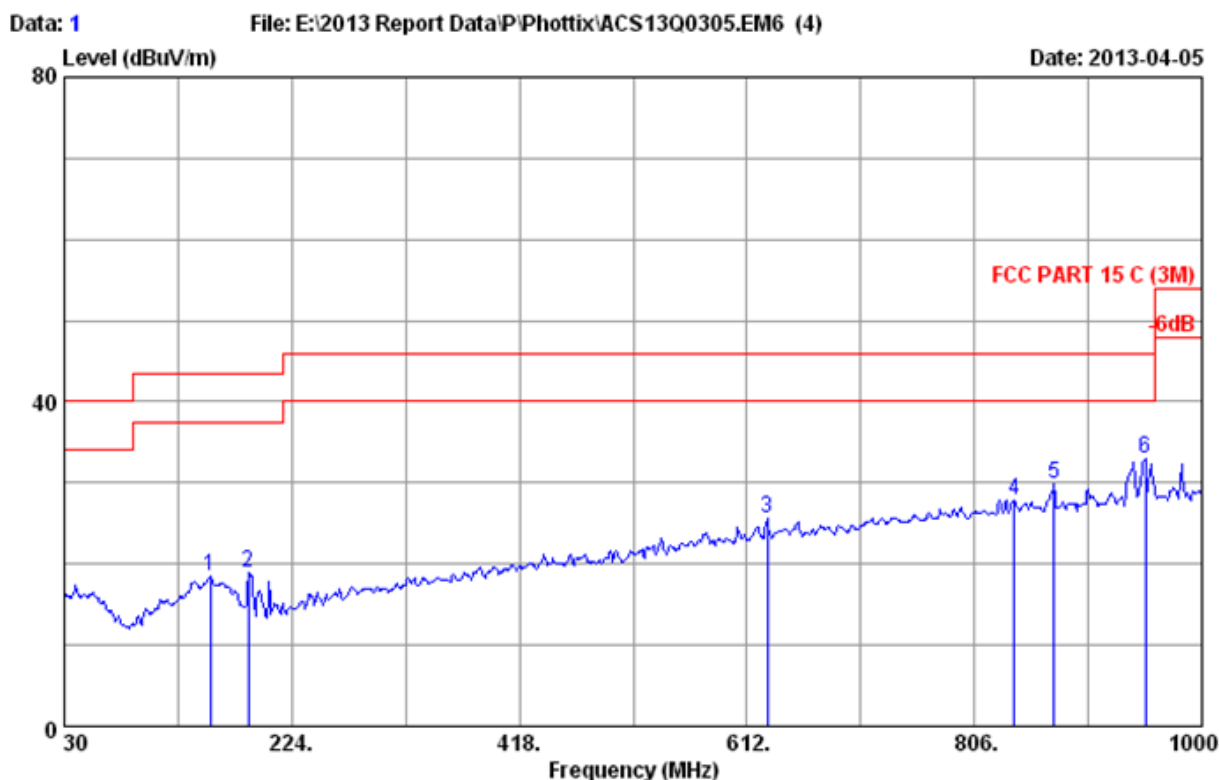

Site no. : 3m Chamber Data no. : 1  
 Dis. / Ant. : 3m 9168-429 Ant. pol. : HORIZONTAL  
 Limit : FCC PART 15 C (3M)  
 Env. / Ins. : 24\*C/65% Engineer : Leo-Li  
 EUT : Phottix Aion Wireless Timer Remote Transmitter  
 Power rating : DC 3V  
 Test Mode : Tx Mode  
 M/N:Aion

No.	Freq. (MHz)	Ant. Factor (dB/m)	Cable Loss (dB)	Reading (dBuV)	Emission Level (dBuV/m)	Limits (dBuV/m)	Margin (dB)	Remark
1	154.160	14.15	0.97	3.47	18.59	43.50	24.91	QP
2	187.140	10.82	1.03	7.01	18.86	43.50	24.64	QP
3	629.460	18.85	2.21	4.64	25.70	46.00	20.30	QP
4	839.950	20.97	2.75	4.21	27.93	46.00	18.07	QP
5	873.900	21.31	2.78	5.67	29.76	46.00	16.24	QP
6	951.500	22.14	2.87	7.98	32.99	46.00	13.01	QP

Remarks: 1. Emission Level= Antenna Factor + Cable Loss + Reading.  
 2. The emission levels that are 20dB below the official limit are not reported.

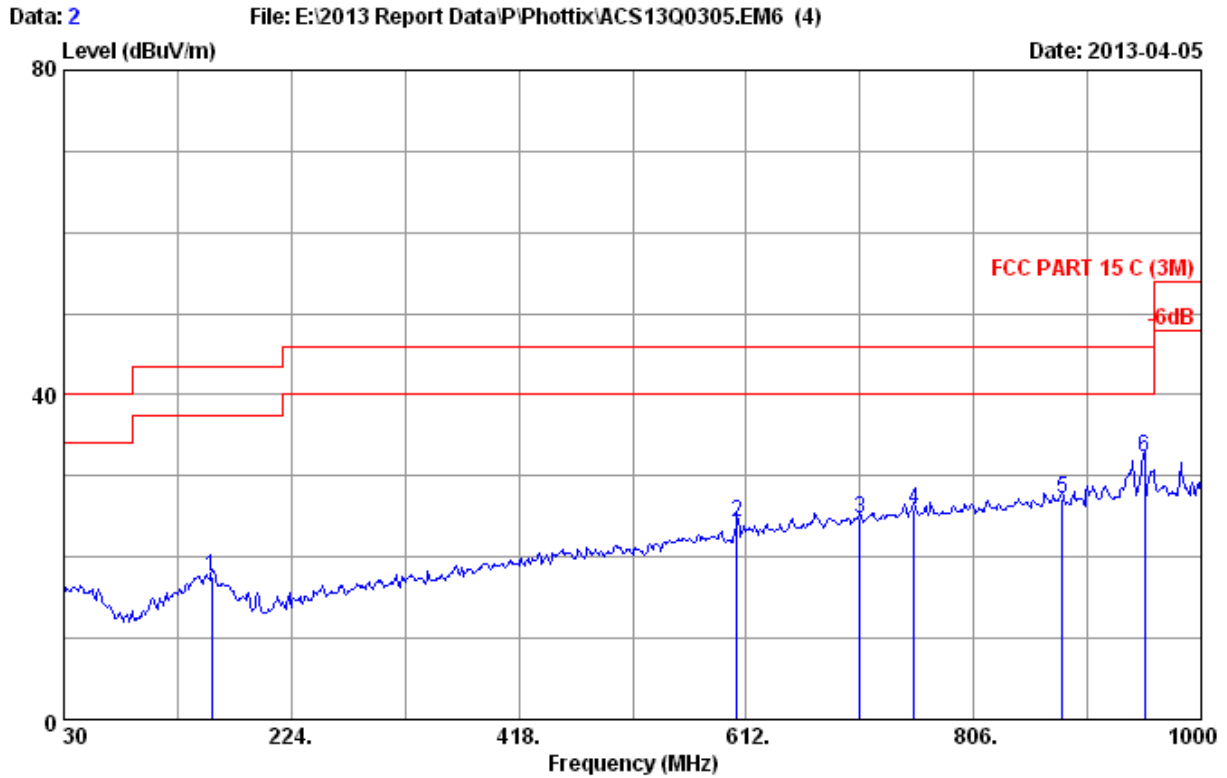

Site no. : 3m Chamber Data no. : 2  
 Dis. / Ant. : 3m 9168-429 Ant. pol. : VERTICAL  
 Limit : FCC PART 15 C (3M)  
 Env. / Ins. : 24°C/65% Engineer : Leo-Li  
 EUT : Phottix Aion Wireless Timer Remote Transmitter  
 Power rating : DC 3V  
 Test Mode : Tx Mode  
 M/N:Aion

No.	Freq. (MHz)	Ant. Factor (dB/m)	Cable Loss (dB)	Reading (dBuV)	Emission Level (dBuV/m)	Limits (dBuV/m)	Margin (dB)	Remark
1	156.100	14.15	0.97	2.41	17.53	43.50	25.97	QP
2	604.240	18.40	2.13	3.86	24.39	46.00	21.61	QP
3	709.000	19.76	2.44	2.44	24.64	46.00	21.36	QP
4	755.560	20.33	2.58	2.89	25.80	46.00	20.20	QP
5	881.660	21.41	2.79	2.93	27.13	46.00	18.87	QP
6	951.500	22.14	2.87	7.20	32.21	46.00	13.79	QP

Remarks: 1. Emission Level= Antenna Factor + Cable Loss + Reading.  
 2. The emission levels that are 20dB below the official limit are not reported.

Frequency: 1GHz~18GHz

Data: 1

File: G:\2013 report\Phottix\ACS13Q0305.EM6 (44)

Date: 2013-04-04

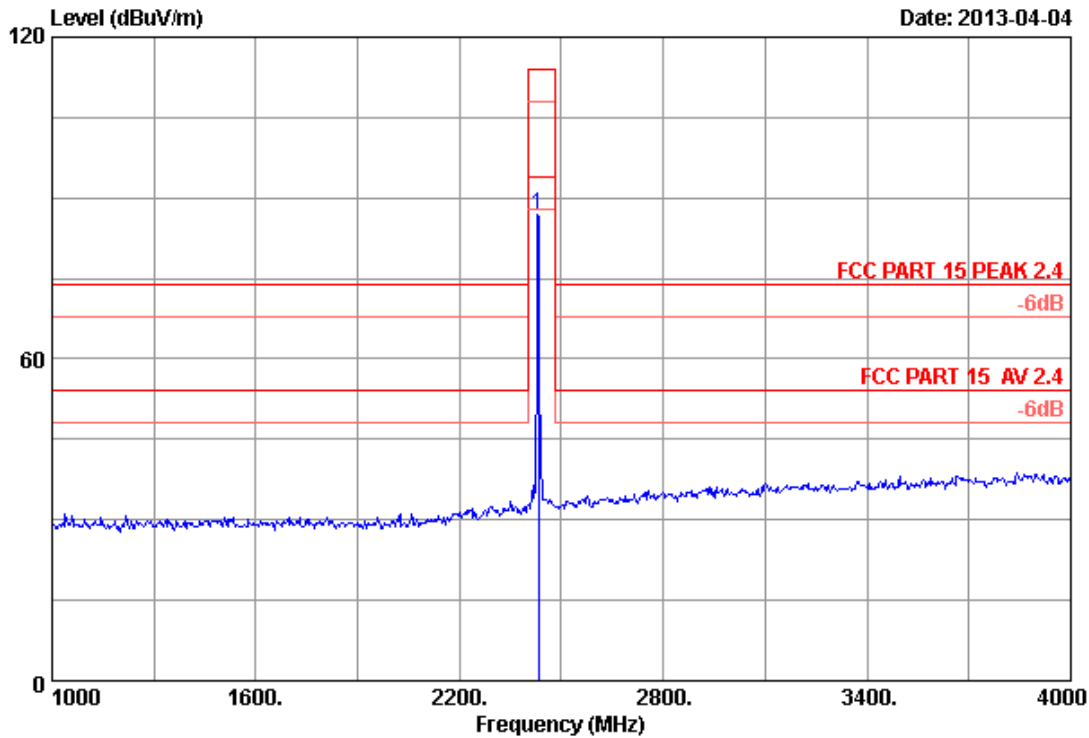

Site no. : 3m Chamber Data no. : 1  
 Dis. / Ant. : 3m 2012 3115 (4580) Ant. pol. : HORIZONTAL  
 Limit : FCC PART 15 PEAK 2.4  
 Env. / Ins. : 23\*C/54% Engineer : Leo-Li  
 EUT : Phottix Aion Wireless Timer Remote Transmitter  
 Power supply : DC 3V  
 Test mode : 2432MHz Tx  
 M/N : Aion  
 :

	Ant.	Cable	Amp.	Emission				
Freq.	Factor	loss	Factor	Reading	Level	Limits	Margin	Remark
(MHz)	(dB/m)	(dB)	(dB)	(dBuV)	(dBuV/m)	(dBuV/m)	(dB)	
1 2432.000	26.96	6.07	35.92	89.87	86.98	114.00	27.02	Peak

Remarks:

1. Emission Level= Antenna Factor + Cable Loss -Amp Factor + Reading.
2. The emission levels that are 20dB below the official limit are not reported.



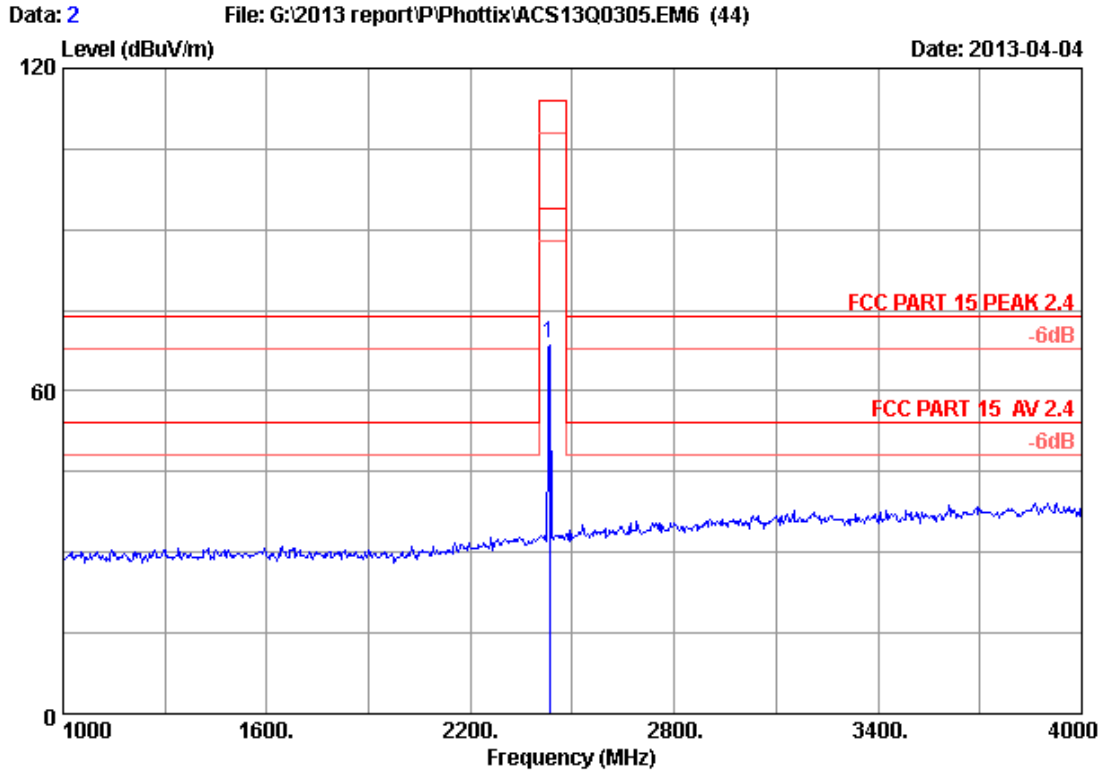

Site no. : 3m Chamber Data no. : 2  
 Dis. / Ant. : 3m 2012 3115 (4580) Ant. pol. : VERTICAL  
 Limit : FCC PART 15 PEAK 2.4  
 Env. / Ins. : 23°C/54% Engineer : Leo-Li  
 EUT : Phottix Aion Wireless Timer Remote Transmitter  
 Power supply : DC 3V  
 Test mode : 2432MHz Tx  
 M/N : Aion  
 :

	Ant. Factor	Cable loss	Amp. Factor	Emission Reading	Emission Level	Limits	Margin	Remark
Freq. (MHz)	(dB/m)	(dB)	(dB)	(dBuV)	(dBuV/m)	(dBuV/m)	(dB)	
1 2432.000	26.96	6.07	35.92	71.64	68.75	114.00	45.25	Peak

Remarks:

1. Emission Level= Antenna Factor + Cable Loss -Amp Factor + Reading.
2. The emission levels that are 20dB below the official limit are not reported.

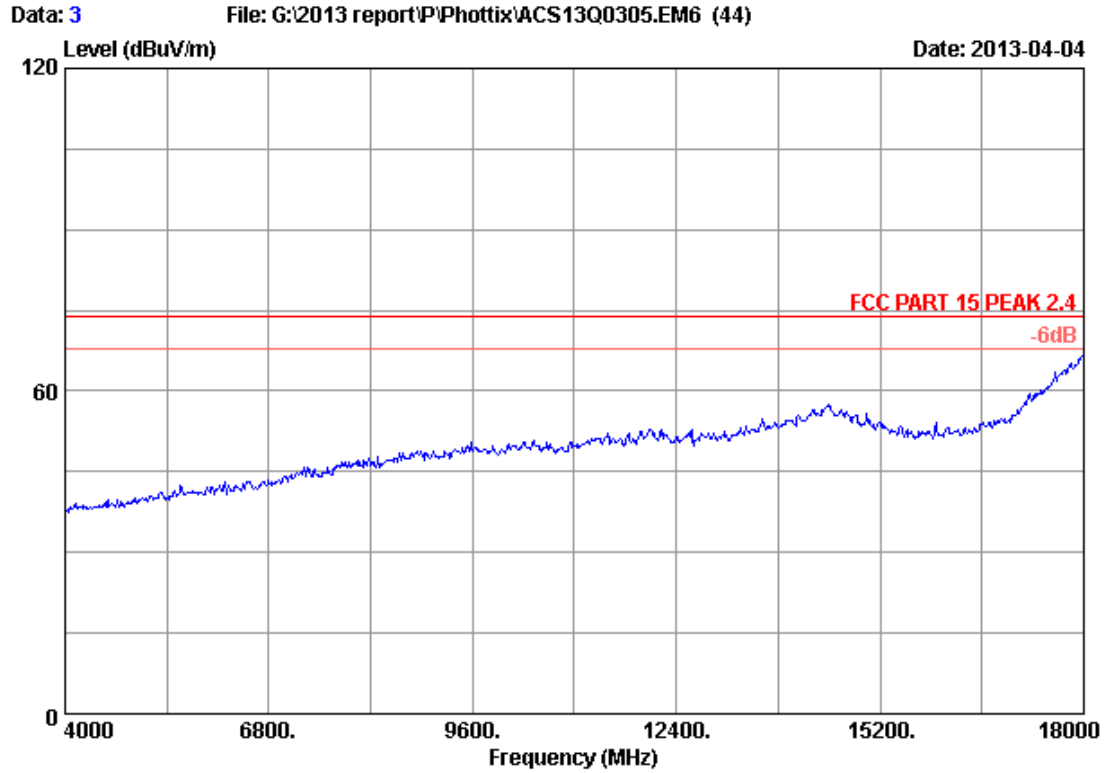

Site no. : 3m Chamber Data no. : 3  
Dis. / Ant. : 3m 2012 3115 (4580) Ant. pol. : VERTICAL  
Limit : FCC PART 15 PEAK 2.4  
Env. / Ins. : 23°C/54% Engineer : Leo-Li  
EUT : Phottix Aion Wireless Timer Remote Transmitter  
Power supply : DC 3V  
Test mode : 2432MHz Tx  
M/N : Aion  
:

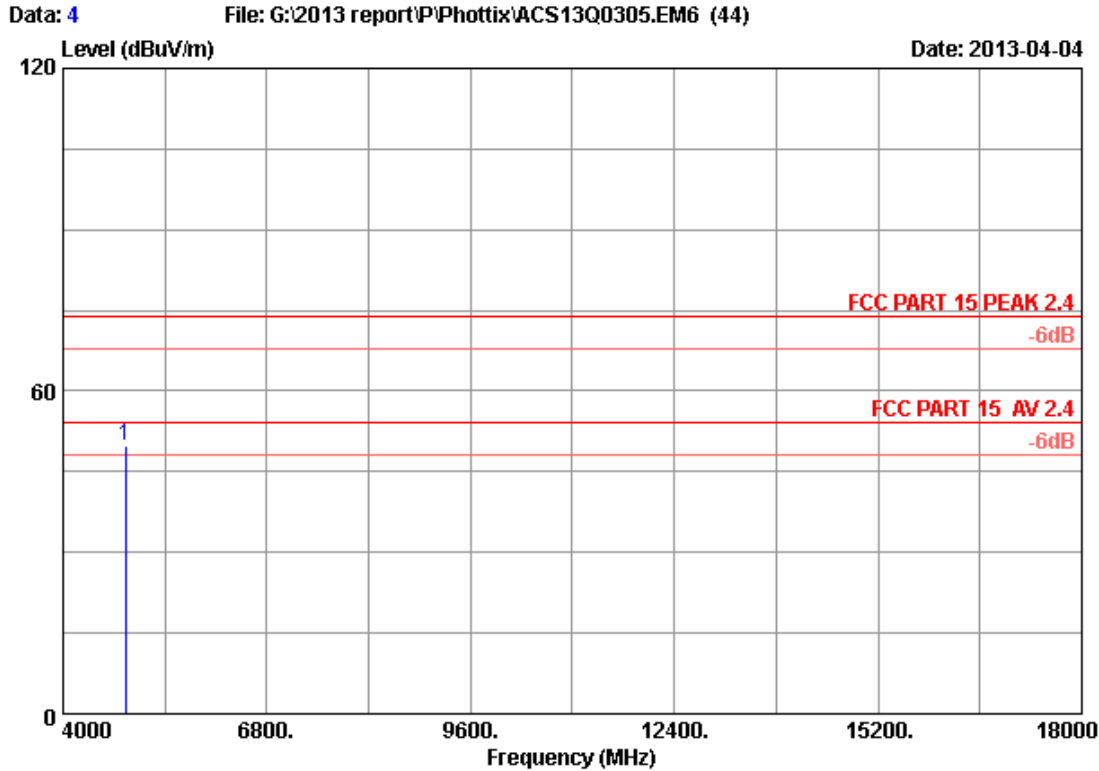

Site no. : 3m Chamber Data no. : 4  
 Dis. / Ant. : 3m 2012 3115 (4580) Ant. pol. : VERTICAL  
 Limit : FCC PART 15 PEAK 2.4  
 Env. / Ins. : 23°C/54% Engineer : Leo-Li  
 EUT : Phottix Aion Wireless Timer Remote Transmitter  
 Power supply : DC 3V  
 Test mode : 2432MHz Tx  
 M/N : Aion  
 :

	Ant. Factor (dB/m)	Cable loss (dB)	Amp. Factor (dB)	Reading (dBuV)	Emission Level (dBuV/m)	Limits (dBuV/m)	Margin (dB)	Remark
1	32.60	8.72	35.70	44.24	49.86	74.00	24.14	Peak

Remarks:

1. Emission Level= Antenna Factor + Cable Loss -Amp Factor + Reading.
2. The emission levels that are 20dB below the official limit are not reported.

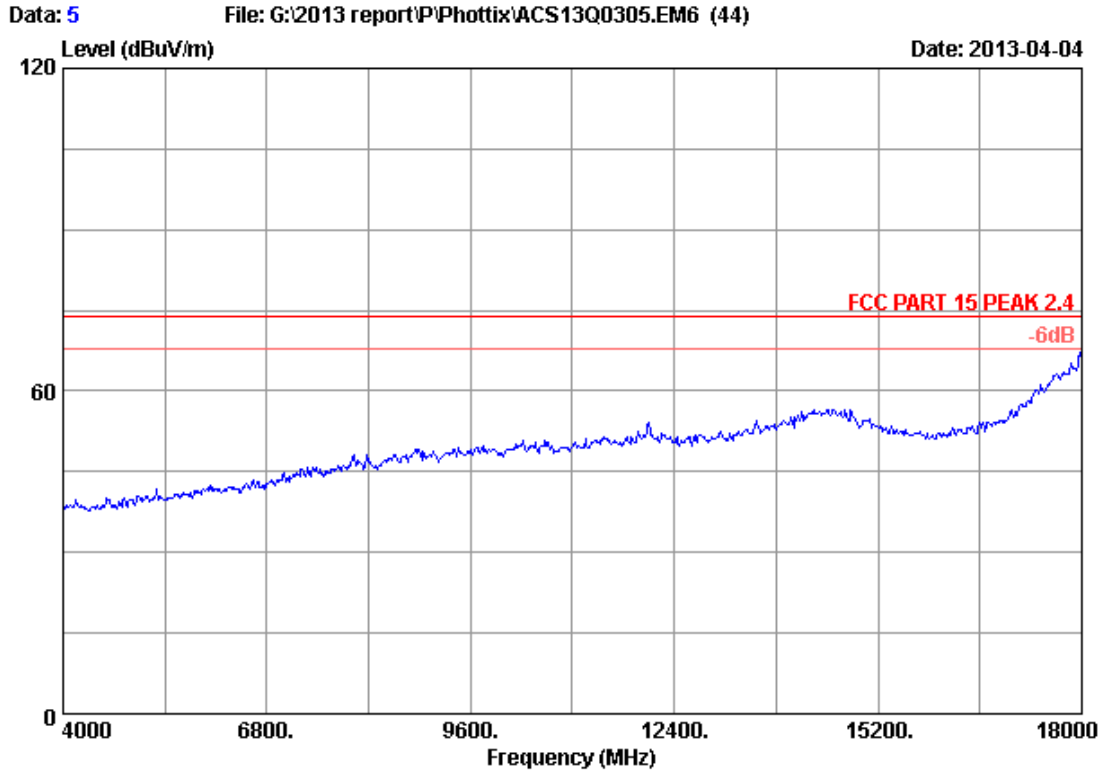

Site no. : 3m Chamber Data no. : 5  
Dis. / Ant. : 3m 2012 3115 (4580) Ant. pol. : HORIZONTAL  
Limit : FCC PART 15 PEAK 2.4  
Env. / Ins. : 23°C/54% Engineer : Leo-Li  
EUT : Phottix Aion Wireless Timer Remote Transmitter  
Power supply : DC 3V  
Test mode : 2432MHz Tx  
M/N : Aion  
:

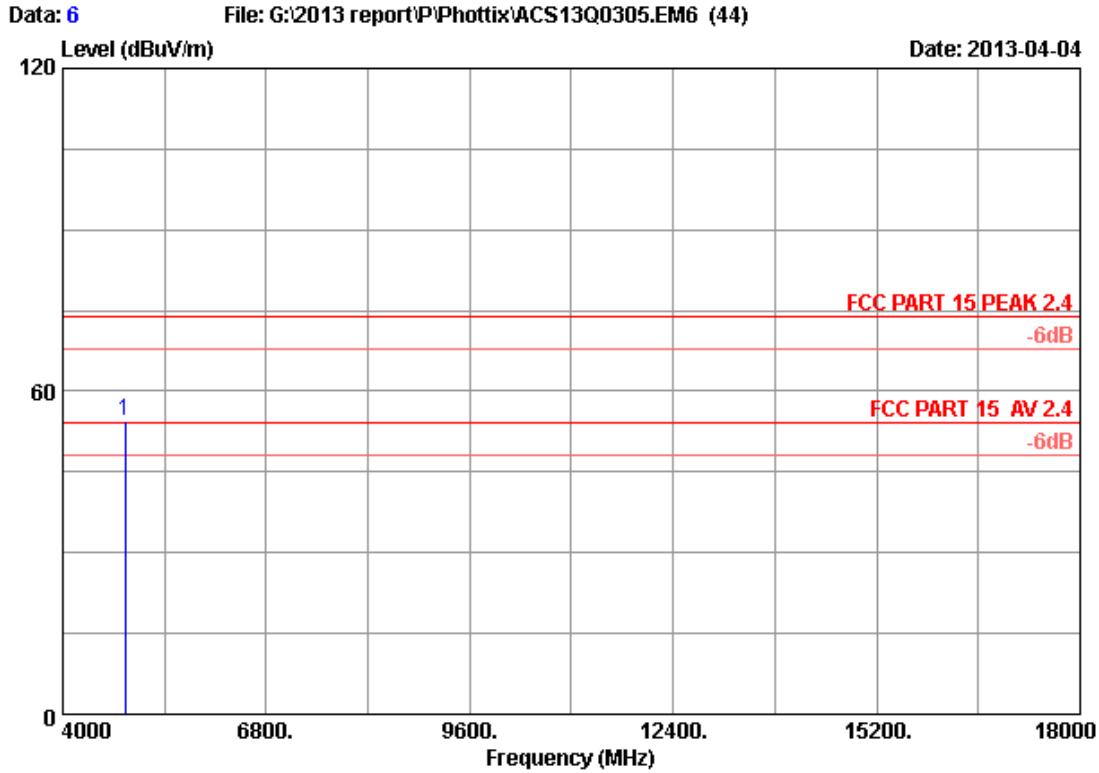

Site no. : 3m Chamber Data no. : 6  
 Dis. / Ant. : 3m 2012 3115 (4580) Ant. pol. : HORIZONTAL  
 Limit : FCC PART 15 PEAK 2.4  
 Env. / Ins. : 23°C/54% Engineer : Leo-Li  
 EUT : Phottix Aion Wireless Timer Remote Transmitter  
 Power supply : DC 3V  
 Test mode : 2432MHz Tx  
 M/N : Aion  
 :

	Ant. Factor	Cable loss	Amp. Factor	Reading	Emission Level	Limits	Margin	Remark
Freq. (MHz)	(dB/m)	(dB)	(dB)	(dBuV)	(dBuV/m)	(dBuV/m)	(dB)	
1 4864.000	32.60	8.72	35.70	48.99	54.61	74.00	19.39	Peak

Remarks:

1. Emission Level= Antenna Factor + Cable Loss -Amp Factor + Reading.
2. The emission levels that are 20dB below the official limit are not reported.

Frequency (MHz)	Peak level (dBuV/m)	Duty cycle factor (dB)	AV level (dBuV/m)	Limit(dBuV/m)	Conclusion
4864	54.61	27.8	26.81	54	Pass

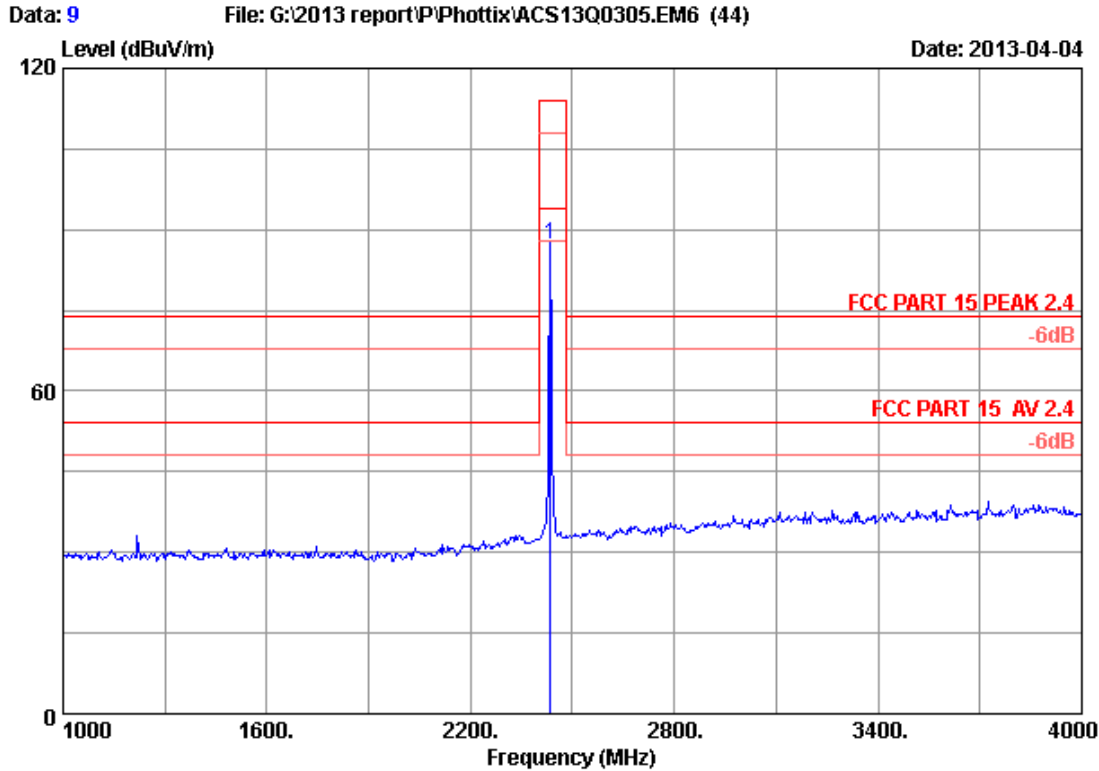

Site no. : 3m Chamber Data no. : 9  
 Dis. / Ant. : 3m 2012 3115 (4580) Ant. pol. : HORIZONTAL  
 Limit : FCC PART 15 PEAK 2.4  
 Env. / Ins. : 23°C/54% Engineer : Leo-Li  
 EUT : Phottix Aion Wireless Timer Remote Transmitter  
 Power supply : DC 3V  
 Test mode : 2435MHz Tx  
 M/N : Aion  
 :

	Freq. (MHz)	Ant. Factor (dB/m)	Cable loss (dB)	Amp. Factor (dB)	Reading (dBuV)	Emission			Remark
						Level (dBuV/m)	Limits (dBuV/m)	Margin (dB)	
1	2435.000	26.98	6.08	35.92	90.02	87.16	114.00	26.84	Peak

Remarks:

1. Emission Level= Antenna Factor + Cable Loss -Amp Factor + Reading.
2. The emission levels that are 20dB below the official limit are not reported.

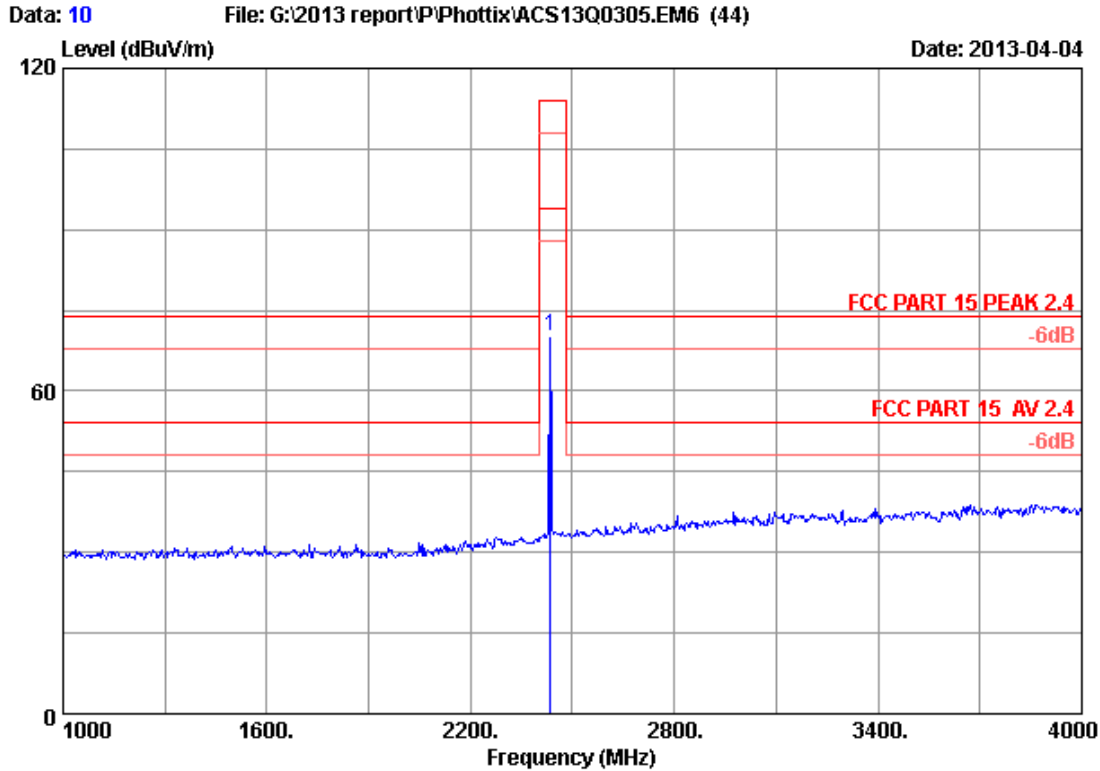

Site no. : 3m Chamber Data no. : 10  
 Dis. / Ant. : 3m 2012 3115 (4580) Ant. pol. : VERTICAL  
 Limit : FCC PART 15 PEAK 2.4  
 Env. / Ins. : 23°C/54% Engineer : Leo-Li  
 EUT : Phottix Aion Wireless Timer Remote Transmitter  
 Power supply : DC 3V  
 Test mode : 2435MHz Tx  
 M/N : Aion  
 :

	Ant. Factor	Cable loss	Amp. Factor	Emission Reading	Emission Level	Limits	Margin	Remark
Freq. (MHz)	(dB/m)	(dB)	(dB)	(dBuV)	(dBuV/m)	(dBuV/m)	(dB)	
1 2435.000	26.98	6.08	35.92	73.22	70.36	114.00	43.64	Peak

Remarks:

1. Emission Level= Antenna Factor + Cable Loss -Amp Factor + Reading.
2. The emission levels that are 20dB below the official limit are not reported.

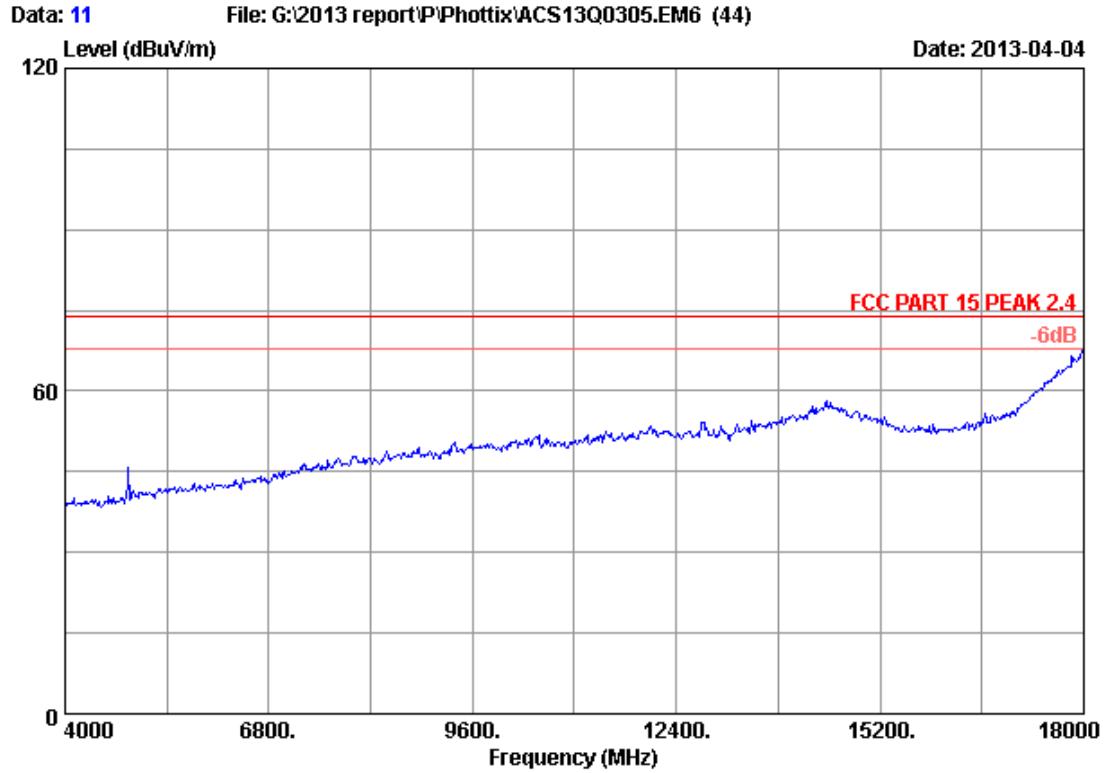

Site no. : 3m Chamber Data no. : 11  
Dis. / Ant. : 3m 2012 3115 (4580) Ant. pol. : VERTICAL  
Limit : FCC PART 15 PEAK 2.4  
Env. / Ins. : 23°C/54% Engineer : Leo-Li  
EUT : Phottix Aion Wireless Timer Remote Transmitter  
Power supply : DC 3V  
Test mode : 2435MHz Tx  
M/N : Aion  
:



Data: 12 File: G:\2013 report\PI\Phottix\ACS13Q0305.EM6 (44) Date: 2013-04-04

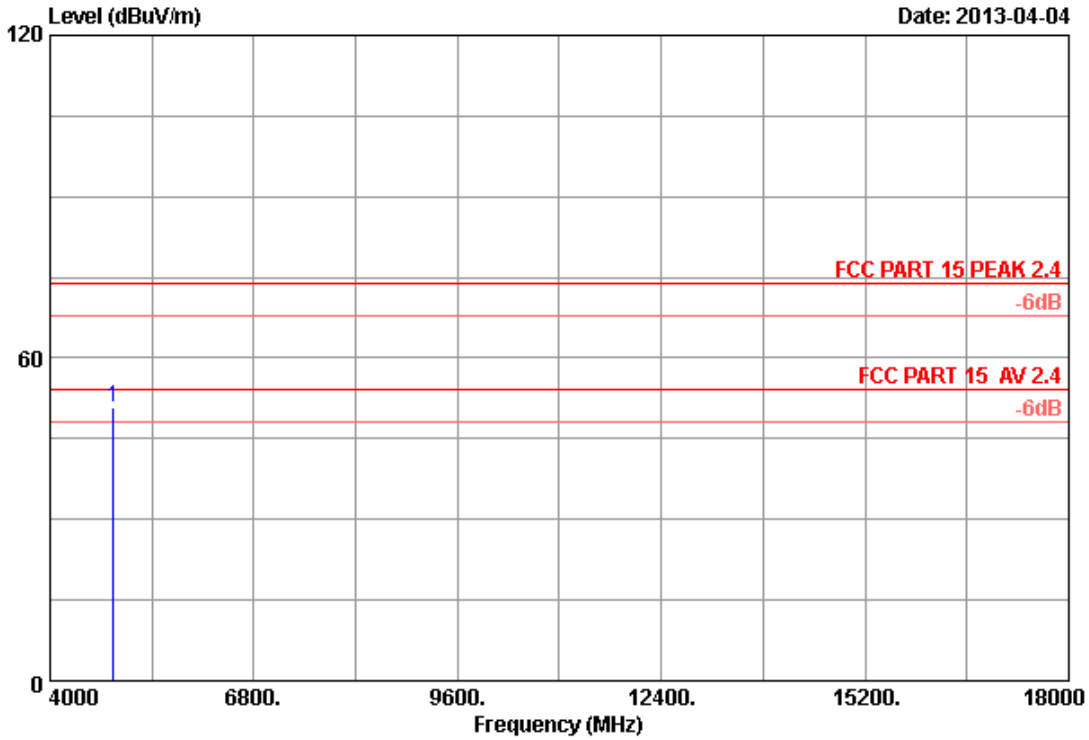

Site no. : 3m Chamber Data no. : 12  
 Dis. / Ant. : 3m 2012 3115 (4580) Ant. pol. : VERTICAL  
 Limit : FCC PART 15 PEAK 2.4  
 Env. / Ins. : 23°C/54% Engineer : Leo-Li  
 EUT : Phottix Aion Wireless Timer Remote Transmitter  
 Power supply : DC 3V  
 Test mode : 2435MHz Tx  
 M/N : Aion  
 :

	Ant.	Cable	Amp.	Emission				
Freq.	Factor	loss	Factor	Reading	Level	Limits	Margin	Remark
(MHz)	(dB/m)	(dB)	(dB)	(dBuV)	(dBuV/m)	(dBuV/m)	(dB)	
1 4870.000	32.61	8.73	35.70	45.02	50.66	74.00	23.34	Peak

Remarks:

1. Emission Level= Antenna Factor + Cable Loss -Amp Factor + Reading.
2. The emission levels that are 20dB below the official limit are not reported.

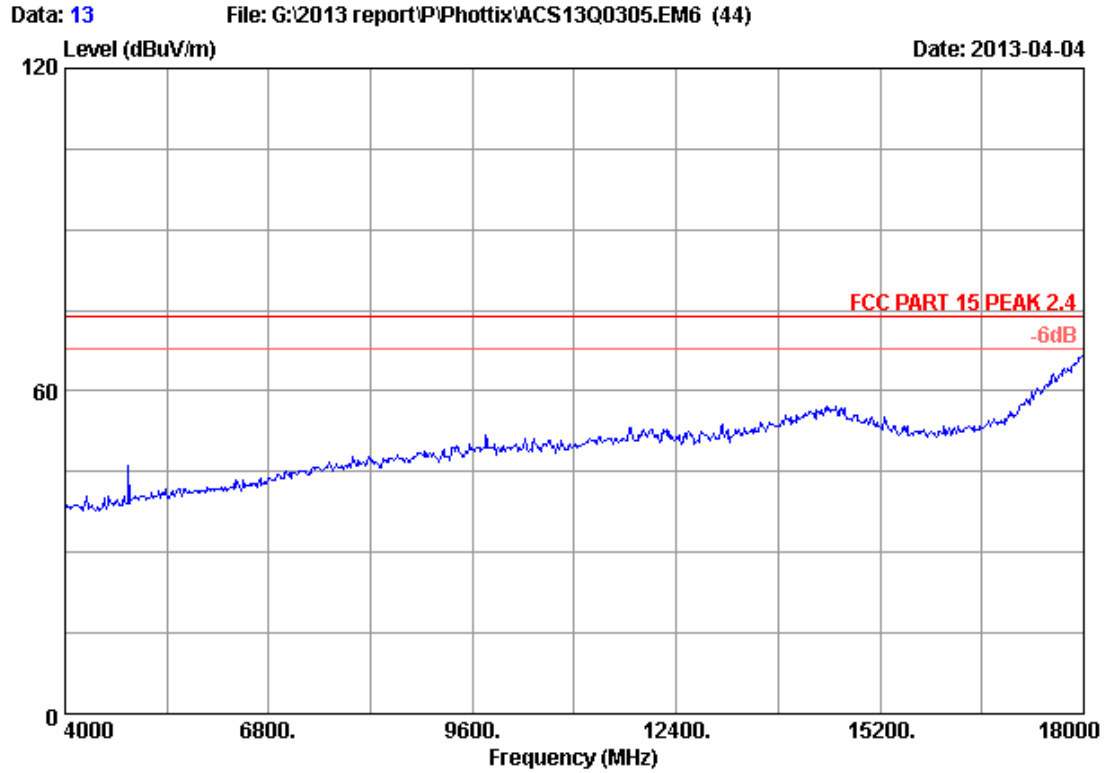

Site no. : 3m Chamber Data no. : 13  
Dis. / Ant. : 3m 2012 3115 (4580) Ant. pol. : HORIZONTAL  
Limit : FCC PART 15 PEAK 2.4  
Env. / Ins. : 23°C/54% Engineer : Leo-Li  
EUT : Phottix Aion Wireless Timer Remote Transmitter  
Power supply : DC 3V  
Test mode : 2435MHz Tx  
M/N : Aion  
:

Data: 14 File: G:\2013 report\PI\Phottix\ACS13Q0305.EM6 (44) Date: 2013-04-04

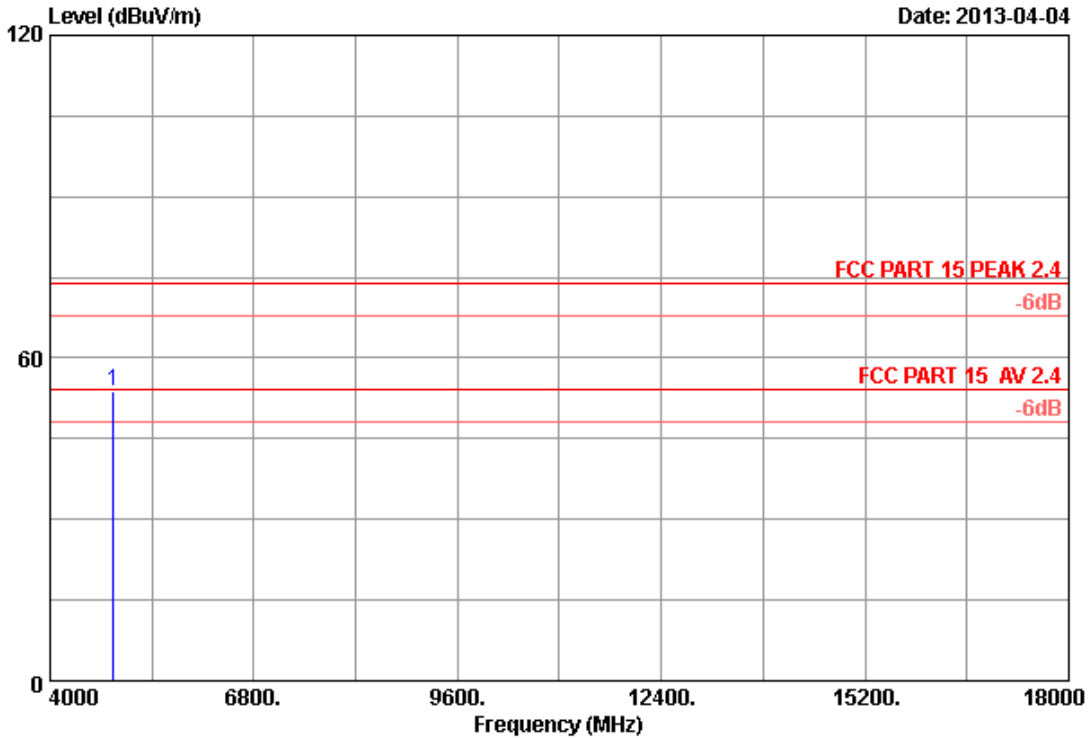

Site no. : 3m Chamber Data no. : 14  
 Dis. / Ant. : 3m 2012 3115 (4580) Ant. pol. : HORIZONTAL  
 Limit : FCC PART 15 PEAK 2.4  
 Env. / Ins. : 23°C/54% Engineer : Leo-Li  
 EUT : Phottix Aion Wireless Timer Remote Transmitter  
 Power supply : DC 3V  
 Test mode : 2435MHz Tx  
 M/N : Aion  
 :

	Ant. Factor (dB/m)	Cable loss (dB)	Amp. Factor (dB)	Reading (dBuV)	Emission Level (dBuV/m)	Limits (dBuV/m)	Margin (dB)	Remark
1	32.61	8.73	35.70	48.18	53.82	74.00	20.18	Peak

Remarks:

1. Emission Level= Antenna Factor + Cable Loss -Amp Factor + Reading.
2. The emission levels that are 20dB below the official limit are not reported.

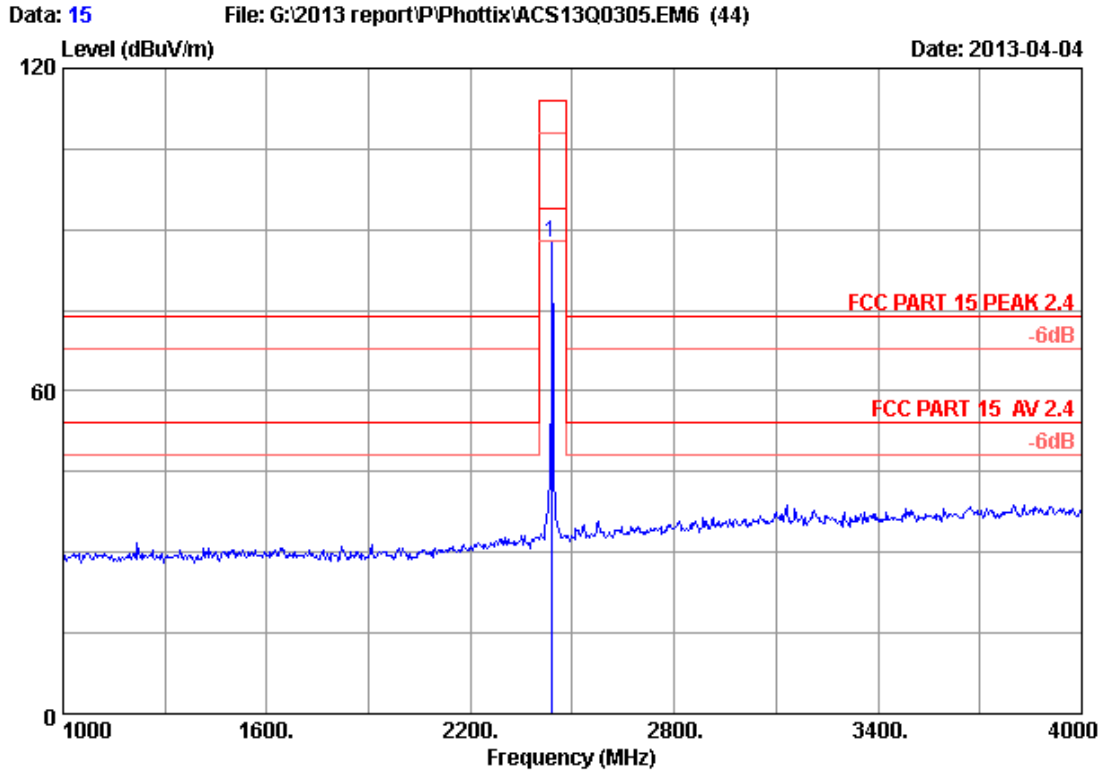

Site no. : 3m Chamber Data no. : 15  
 Dis. / Ant. : 3m 2012 3115 (4580) Ant. pol. : HORIZONTAL  
 Limit : FCC PART 15 PEAK 2.4  
 Env. / Ins. : 23°C/54% Engineer : Leo-Li  
 EUT : Phottix Aion Wireless Timer Remote Transmitter  
 Power supply : DC 3V  
 Test mode : 2439MHz Tx  
 M/N : Aion  
 :

	Ant.	Cable	Amp.	Emission				
Freq.	Factor	loss	Factor	Reading	Level	Limits	Margin	Remark
(MHz)	(dB/m)	(dB)	(dB)	(dBuV)	(dBuV/m)	(dBuV/m)	(dB)	
1 2439.000	27.01	6.08	35.92	90.49	87.66	114.00	26.34	Peak

Remarks:

1. Emission Level= Antenna Factor + Cable Loss -Amp Factor + Reading.
2. The emission levels that are 20dB below the official limit are not reported.

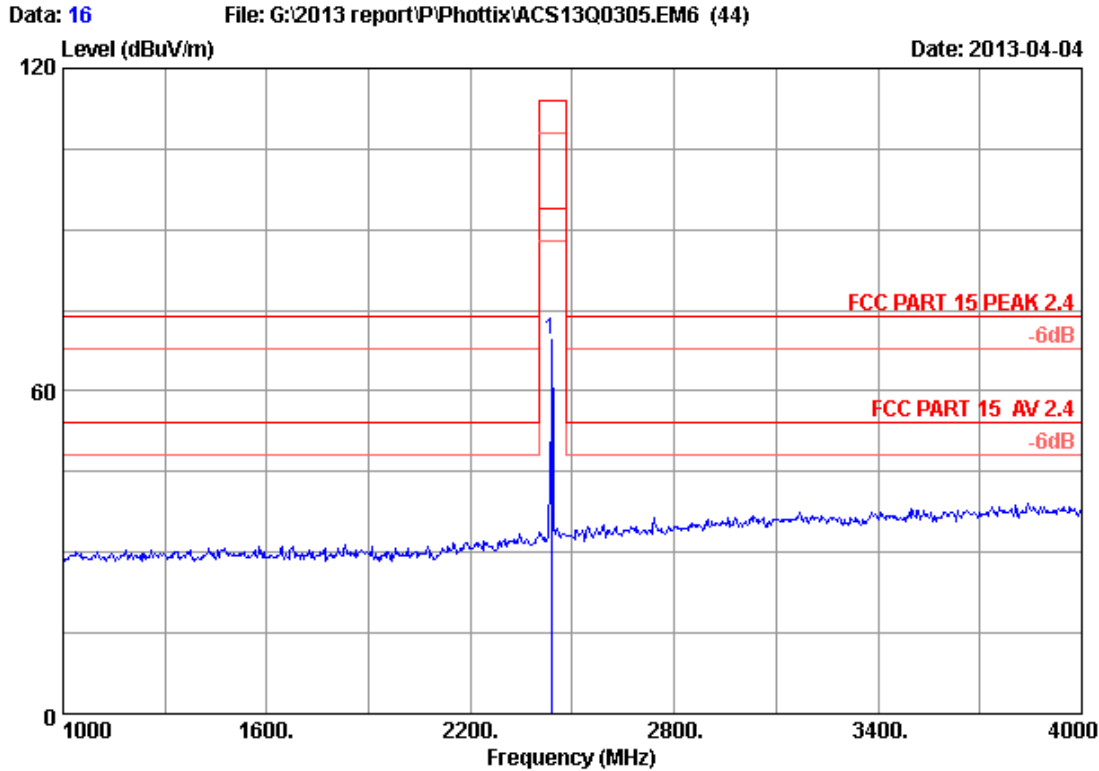

Site no. : 3m Chamber Data no. : 16  
 Dis. / Ant. : 3m 2012 3115 (4580) Ant. pol. : VERTICAL  
 Limit : FCC PART 15 PEAK 2.4  
 Env. / Ins. : 23°C/54% Engineer : Leo-Li  
 EUT : Phottix Aion Wireless Timer Remote Transmitter  
 Power supply : DC 3V  
 Test mode : 2439MHz Tx  
 M/N : Aion  
 :

	Ant.	Cable	Amp.	Emission				
Freq.	Factor	loss	Factor	Reading	Level	Limits	Margin	Remark
(MHz)	(dB/m)	(dB)	(dB)	(dBuV)	(dBuV/m)	(dBuV/m)	(dB)	
1 2439.000	27.01	6.08	35.92	72.33	69.50	114.00	44.50	Peak

Remarks:

1. Emission Level= Antenna Factor + Cable Loss -Amp Factor + Reading.
2. The emission levels that are 20dB below the official limit are not reported.

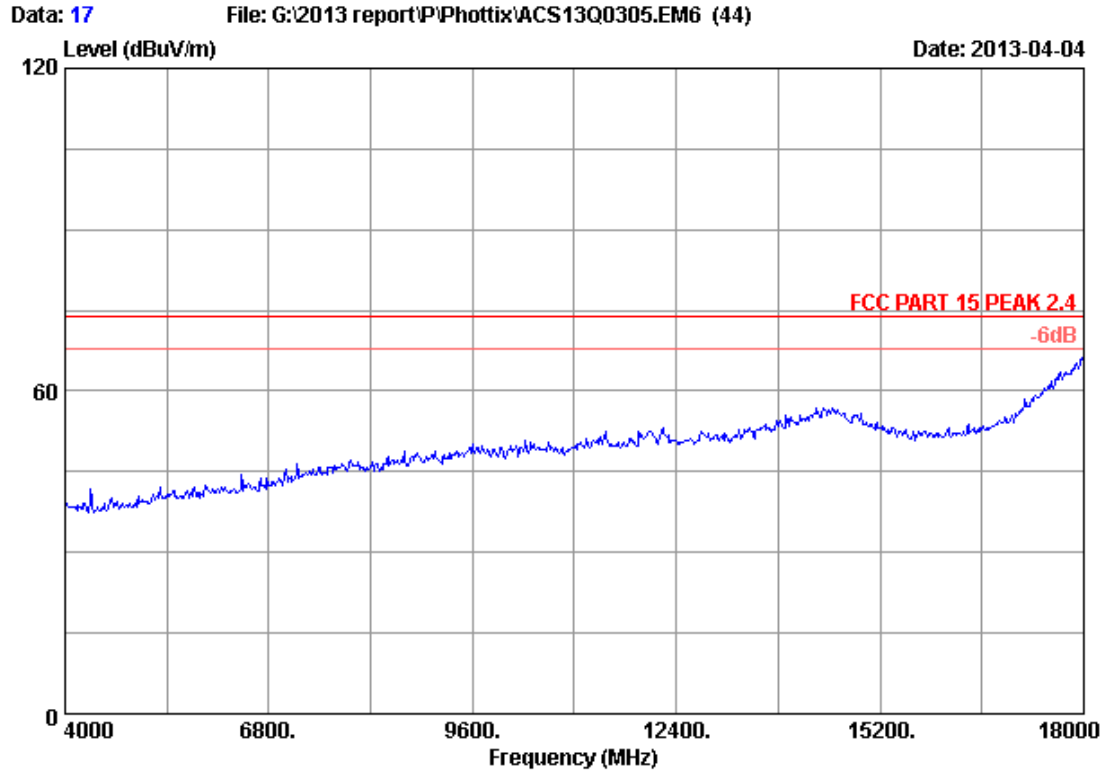

Site no. : 3m Chamber Data no. : 17  
Dis. / Ant. : 3m 2012 3115 (4580) Ant. pol. : VERTICAL  
Limit : FCC PART 15 PEAK 2.4  
Env. / Ins. : 23°C/54% Engineer : Leo-Li  
EUT : Phottix Aion Wireless Timer Remote Transmitter  
Power supply : DC 3V  
Test mode : 2439MHz Tx  
M/N : Aion  
:

Data: 18 File: G:\2013 report\PI\Phottix\ACS13Q0305.EM6 (44) Date: 2013-04-04

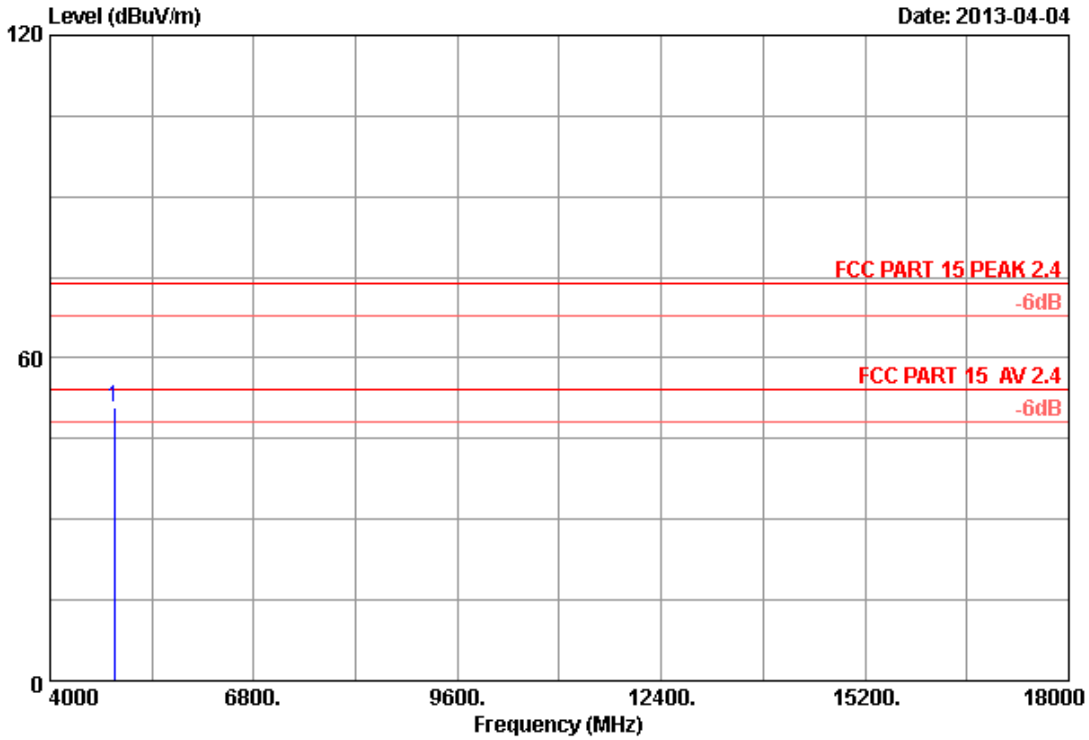

Site no. : 3m Chamber Data no. : 18  
 Dis. / Ant. : 3m 2012 3115 (4580) Ant. pol. : VERTICAL  
 Limit : FCC PART 15 PEAK 2.4  
 Env. / Ins. : 23°C/54% Engineer : Leo-Li  
 EUT : Phottix Aion Wireless Timer Remote Transmitter  
 Power supply : DC 3V  
 Test mode : 2439MHz Tx  
 M/N : Aion  
 :

	Ant. Factor	Cable loss	Amp. Factor	Reading	Emission Level	Limits	Margin	Remark
Freq. (MHz)	(dB/m)	(dB)	(dB)	(dBuV)	(dBuV/m)	(dBuV/m)	(dB)	
1 4878.000	32.63	8.73	35.69	45.09	50.76	74.00	23.24	Peak

Remarks:

1. Emission Level= Antenna Factor + Cable Loss -Amp Factor + Reading.
2. The emission levels that are 20dB below the official limit are not reported.

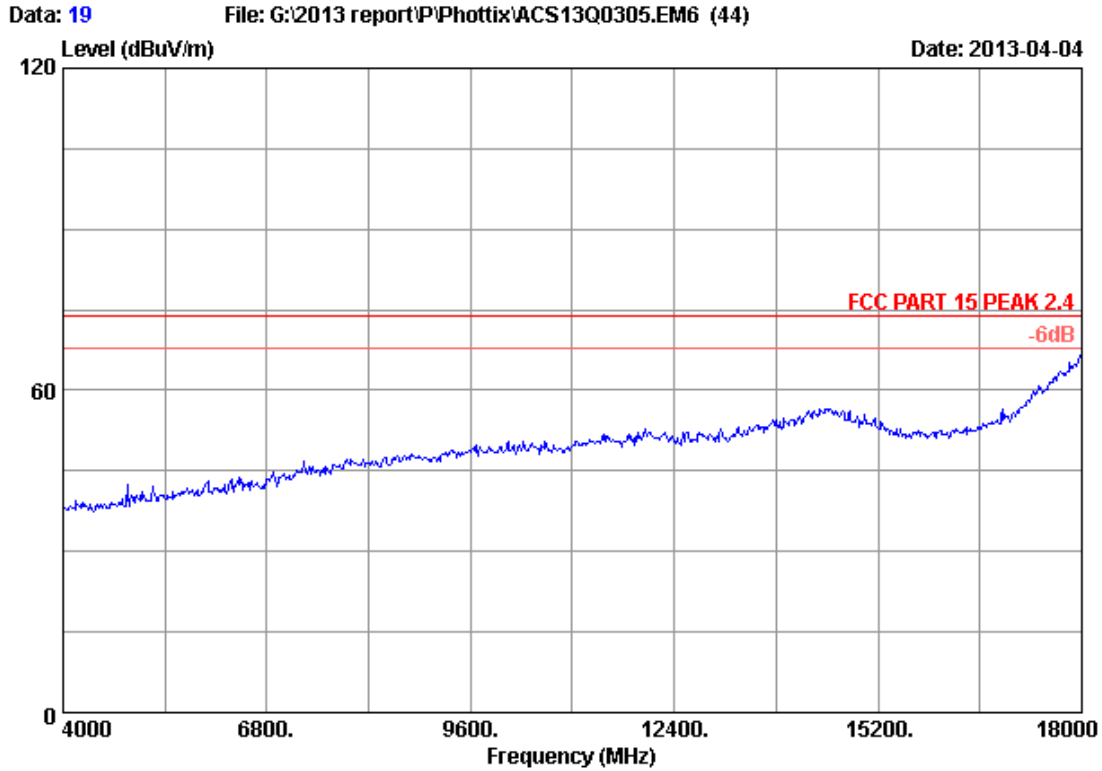

Site no. : 3m Chamber Data no. : 19  
Dis. / Ant. : 3m 2012 3115 (4580) Ant. pol. : HORIZONTAL  
Limit : FCC PART 15 PEAK 2.4  
Env. / Ins. : 23°C/54% Engineer : Leo-Li  
EUT : Phottix Aion Wireless Timer Remote Transmitter  
Power supply : DC 3V  
Test mode : 2439MHz Tx  
M/N : Aion  
:



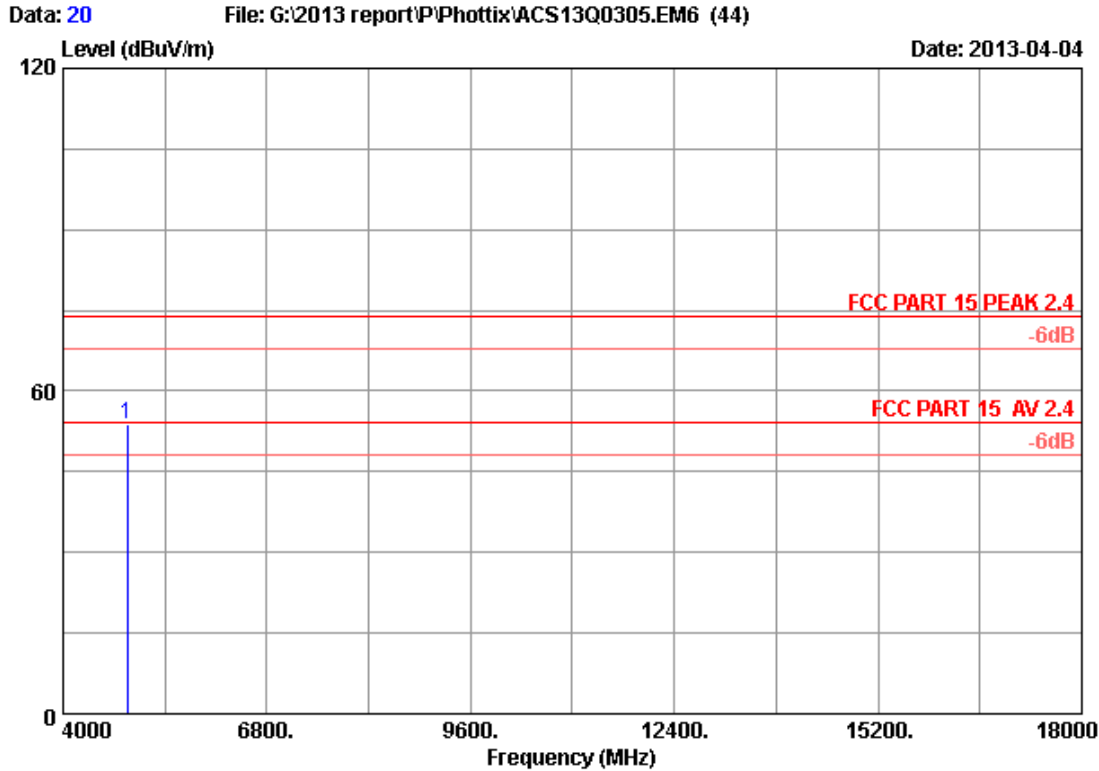

```

Site no.       : 3m Chamber           Data no.    : 20
Dis. / Ant.   : 3m 2012 3115 (4580)  Ant. pol.  : HORIZONTAL
Limit        : FCC PART 15 PEAK 2.4
Env. / Ins.   : 23*C/54%             Engineer   : Leo-Li
EUT          : Phottix Aion Wireless Timer Remote Transmitter
Power supply  : DC 3V
Test mode    : 2439MHz Tx
M/N         : Aion
    
```

	Ant. Factor	Cable loss	Amp. Factor	Reading	Emission Level	Limits	Margin	Remark
Freq. (MHz)	(dB/m)	(dB)	(dB)	(dBuV)	(dBuV/m)	(dBuV/m)	(dB)	
1 4878.000	32.63	8.73	35.69	48.11	53.78	74.00	20.22	Peak

Remarks:

1. Emission Level= Antenna Factor + Cable Loss -Amp Factor + Reading.
2. The emission levels that are 20dB below the official limit are not reported.

## 5. BAND EDGE COMPLIANCE TEST

### 5.1. Test Equipment

Item	Equipment	Manufacturer	Model No.	Serial No.	Last Cal.	Cal. Interval
1.	Spectrum	Agilent	E4446A	US44300459	May.08, 12	1 Year
2.	Amp	HP	8449B	3008A08495	May.08, 12	1 Year
3.	Antenna	EMCO	3115	9510-4580	May.08, 12	1Year
4.	HF Cable	Hubersuhne	Sucoflex104	-	May.08, 12	1 Year

### 5.2. Limit

All the lower and upper band-edges emissions should comply with the radiated emission limit 15.209.

### 5.3. Test Produce

1. The EUT is placed on a turntable, which is 0.8m above the ground plane and worked at highest radiated power.
2. The turntable was rotated for 360 degrees to determine the position of maximum emission level.
3. EUT is set 3m away from the receiving antenna, which is varied from 1m to 4m to find out the highest emission.
4. Set the spectrum analyzer in the following setting in order to capture the lower and upperband-edges of the emission:
  - (a) PEAK: RBW=1MHz ;VBW=3MHz, PK detector, Sweep=AUTO
  - (b) This device is pulse modulated, a duty cycle factor was used to calculate average level based measured peak level

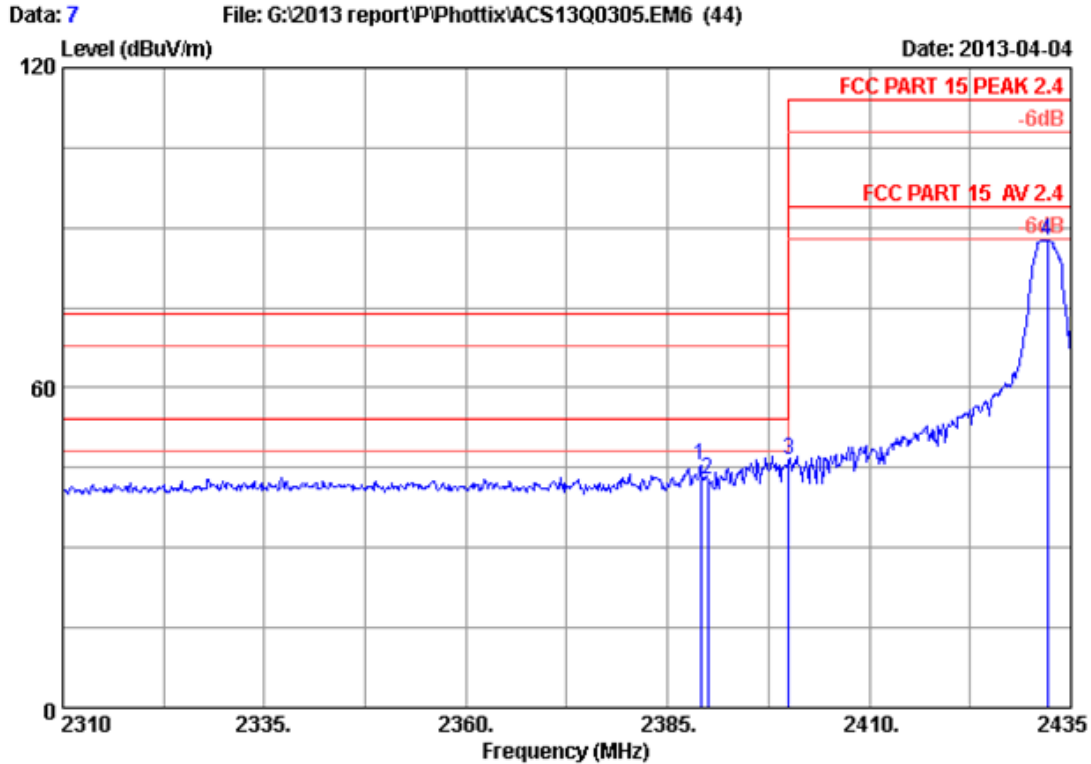

Site no. : 3m Chamber Data no. : 7  
 Dis. / Ant. : 3m 2012 3115 (4580) Ant. pol. : HORIZONTAL  
 Limit : FCC PART 15 PEAK 2.4  
 Env. / Ins. : 23°C/54% Engineer : Leo-Li  
 EUT : Phottix Aion Wireless Timer Remote Transmitter  
 Power supply : DC 3V  
 Test mode : 2432MHz Tx  
 M/N : Aion  
 :

	Freq. (MHz)	Ant. Factor (dB/m)	Cable loss (dB)	Amp. Factor (dB)	Reading (dBuV)	Emission Level (dBuV/m)	Limits (dBuV/m)	Margin (dB)	Remark
1	2389.125	26.69	6.00	35.92	48.66	45.43	74.00	28.57	Peak
2	2390.000	26.70	6.00	35.92	45.88	42.66	74.00	31.34	Peak
3	2400.000	26.76	6.02	35.92	49.60	46.46	74.00	27.54	Peak
4	2432.125	26.97	6.07	35.92	90.62	87.74	114.00	26.26	Peak

Remarks:

1. Emission Level= Antenna Factor + Cable Loss -Amp Factor + Reading.
2. The emission levels that are 20dB below the official limit are not reported.

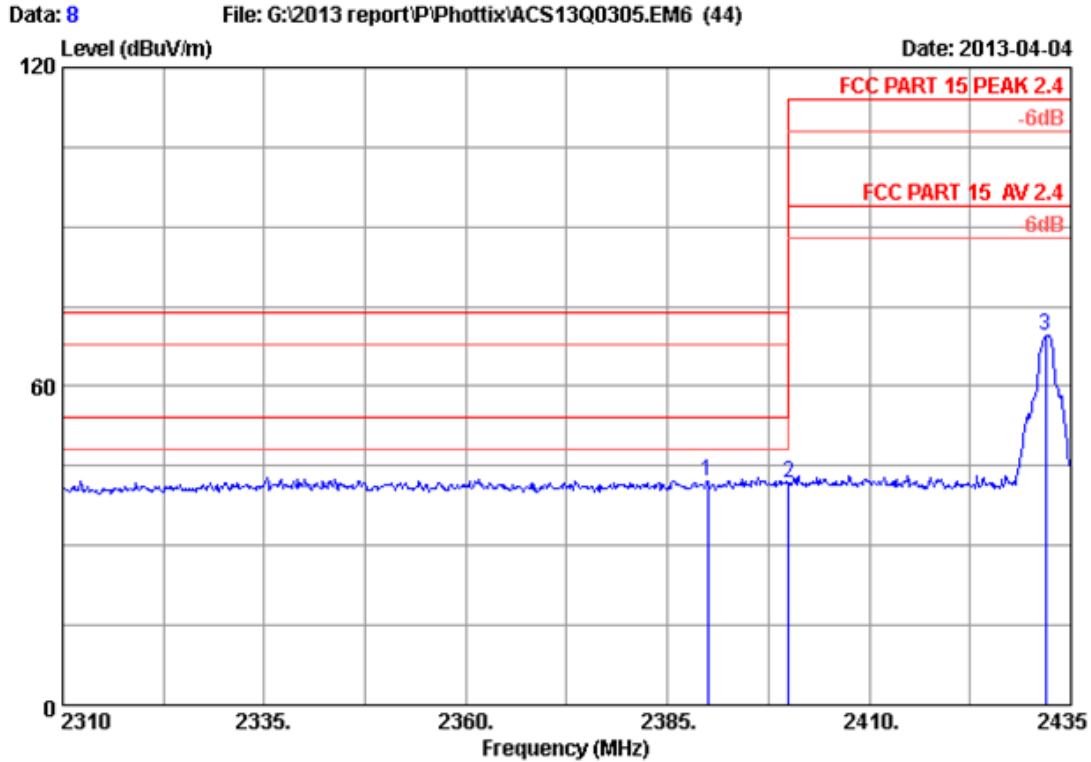

Site no. : 3m Chamber Data no. : 8  
 Dis. / Ant. : 3m 2012 3115 (4580) Ant. pol. : VERTICAL  
 Limit : FCC PART 15 PEAK 2.4  
 Env. / Ins. : 23°C/54% Engineer : Leo-Li  
 EUT : Phottix Aion Wireless Timer Remote Transmitter  
 Power supply : DC 3V  
 Test mode : 2432MHz Tx  
 M/N : Aion  
 :

	Freq. (MHz)	Ant. Factor (dB/m)	Cable loss (dB)	Amp. Factor (dB)	Reading (dBuV)	Emission Level (dBuV/m)	Limits (dBuV/m)	Margin (dB)	Remark
1	2390.000	26.70	6.00	35.92	45.33	42.11	74.00	31.89	Peak
2	2400.000	26.76	6.02	35.92	45.09	41.95	74.00	32.05	Peak
3	2431.875	26.96	6.07	35.92	72.38	69.49	114.00	44.51	Peak

Remarks:

1. Emission Level= Antenna Factor + Cable Loss -Amp Factor + Reading.
2. The emission levels that are 20dB below the official limit are not reported.

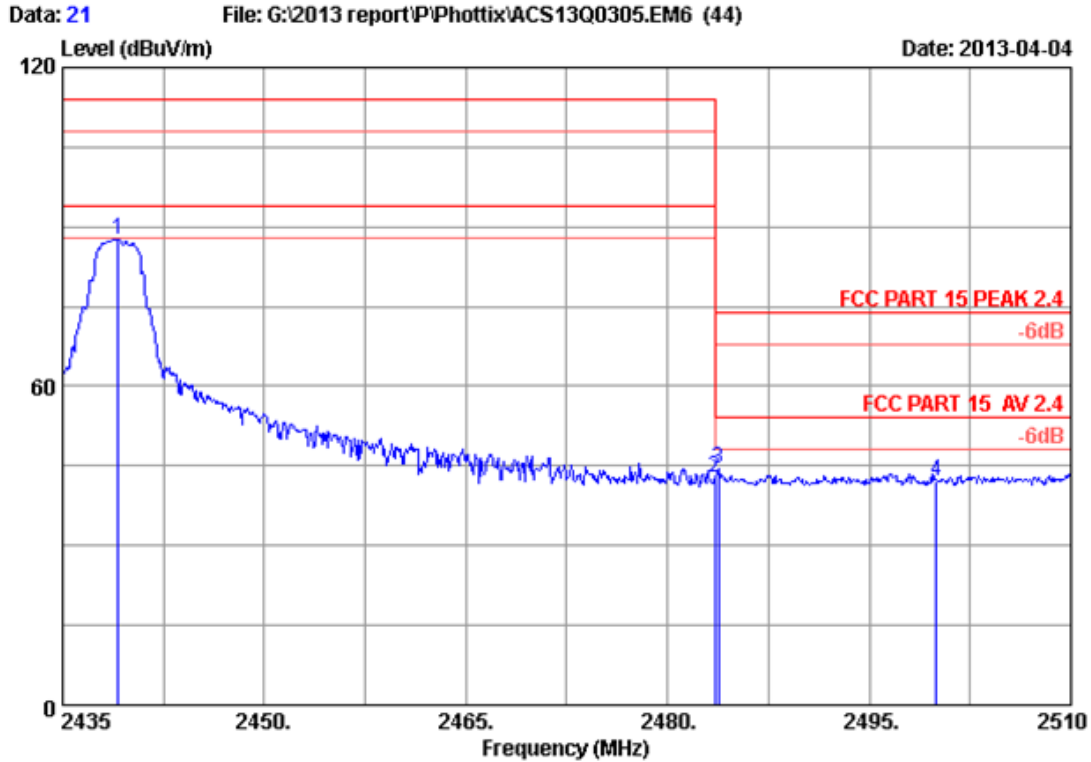

Site no. : 3m Chamber Data no. : 21  
 Dis. / Ant. : 3m 2012 3115 (4580) Ant. pol. : HORIZONTAL  
 Limit : FCC PART 15 PEAK 2.4  
 Env. / Ins. : 23°C/54% Engineer : Leo-Li  
 EUT : Phottix Aion Wireless Timer Remote Transmitter  
 Power supply : DC 3V  
 Test mode : 2439MHz Tx  
 M/N : Aion  
 :

	Freq. (MHz)	Ant. Factor (dB/m)	Cable loss (dB)	Amp. Factor (dB)	Reading (dBuV)	Emission Level (dBuV/m)	Limits (dBuV/m)	Margin (dB)	Remark
1	2439.125	27.01	6.08	35.92	90.40	87.57	114.00	26.43	Peak
2	2483.500	27.29	6.16	35.92	45.28	42.81	74.00	31.19	Peak
3	2483.750	27.30	6.16	35.92	46.81	44.35	74.00	29.65	Peak
4	2500.000	27.40	6.19	35.93	44.42	42.08	74.00	31.92	Peak

Remarks:

1. Emission Level= Antenna Factor + Cable Loss -Amp Factor + Reading.
2. The emission levels that are 20dB below the official limit are not reported.

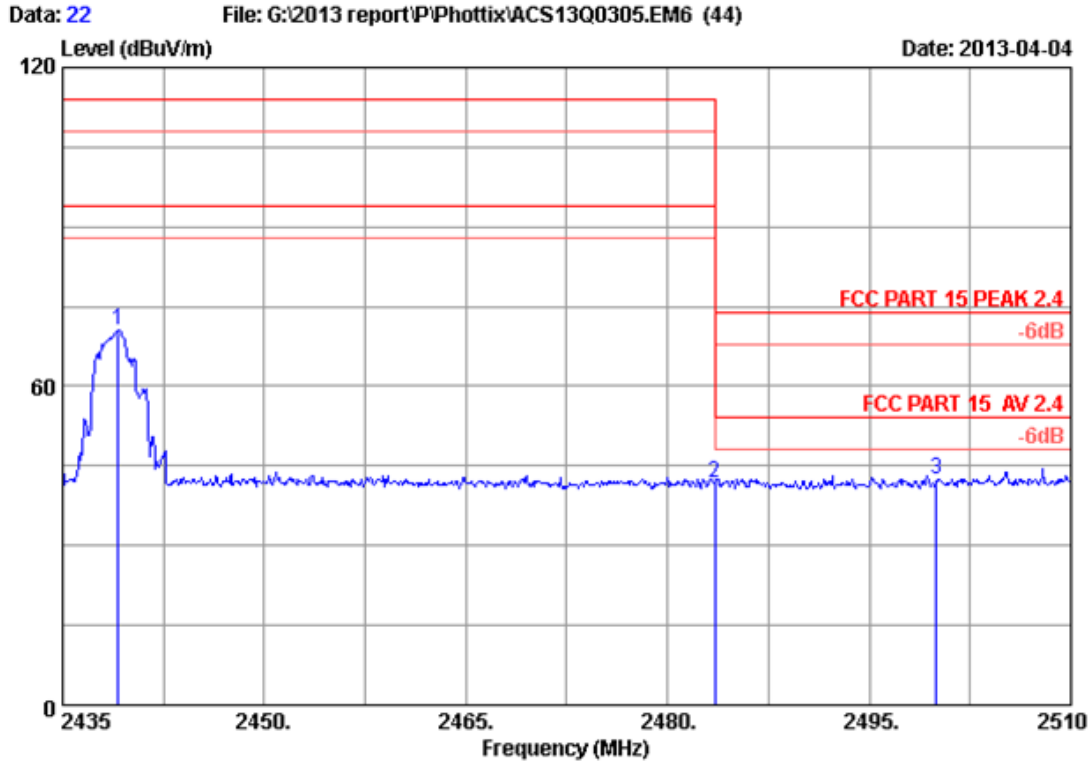

Site no. : 3m Chamber Data no. : 22  
 Dis. / Ant. : 3m 2012 3115 (4580) Ant. pol. : VERTICAL  
 Limit : FCC PART 15 PEAK 2.4  
 Env. / Ins. : 23°C/54% Engineer : Leo-Li  
 EUT : Phottix Aion Wireless Timer Remote Transmitter  
 Power supply : DC 3V  
 Test mode : 2439MHz Tx  
 M/N : Aion  
 :

	Freq. (MHz)	Ant. Factor (dB/m)	Cable loss (dB)	Amp. Factor (dB)	Reading (dBuV)	Emission Level (dBuV/m)	Limits (dBuV/m)	Margin (dB)	Remark
1	2439.125	27.01	6.08	35.92	73.27	70.44	114.00	43.56	Peak
2	2483.500	27.29	6.16	35.92	44.20	41.73	74.00	32.27	Peak
3	2500.000	27.40	6.19	35.93	44.73	42.39	74.00	31.61	Peak

Remarks:

1. Emission Level= Antenna Factor + Cable Loss -Amp Factor + Reading.
2. The emission levels that are 20dB below the official limit are not reported.

## 6. 20 DB BANDWIDTH TEST

### 6.1. Test Equipment

Item	Equipment	Manufacturer	Model No.	Serial No.	Last Cal.	Cal. Interval
1.	Spectrum	Agilent	E4446A	US44300459	May.08, 12	1 Year

### 6.2. Limit

The transmitter shall be operated at its maximum carrier power measured under normal test conditions. The span of the analyzer shall be set to capture all products of the modulation process, including the emission skirts. The resolution bandwidth shall be set to as close to 1% of the selected span as is possible without being below 1%. The video bandwidth shall be set to 3 times the resolution bandwidth.

### 6.3. Test Results

EUT: Phottix Aion Wireless Timer Remote Transmitter		
M/N: Aion		
Test date: 2013-04-04	Pressure: 101.4±1.0 kpa	Humidity: 51.4±3.0%
Tested by: Leo-Li	Test site: RF Site	Temperature : 20.6±0.6 °C

Frequency	20dB bandwidth ( MHz )	Limit (MHz)
2432MHz	2.246	N/A
2435MHz	2.279	N/A
2439MHz	2.243	N/A
Conclusion : PASS		

Test Frequency: 2432MHz

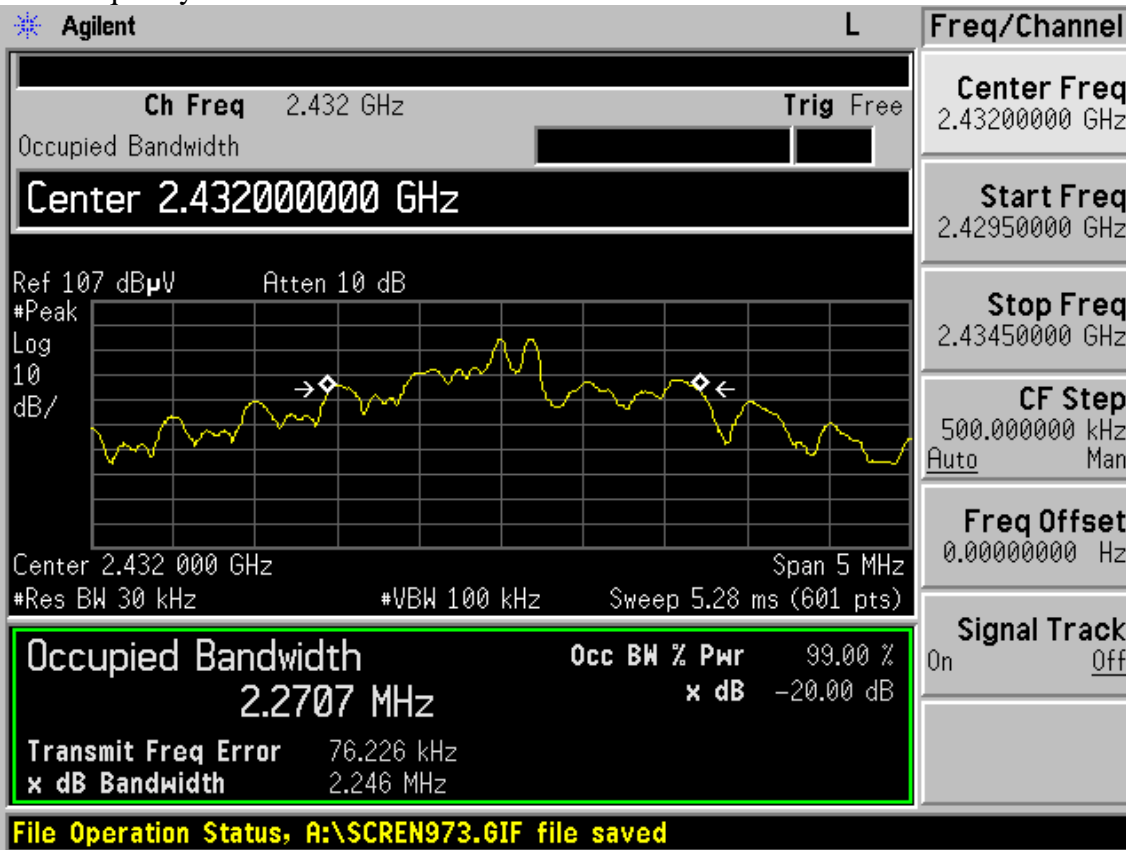

Test Frequency: 2435MHz

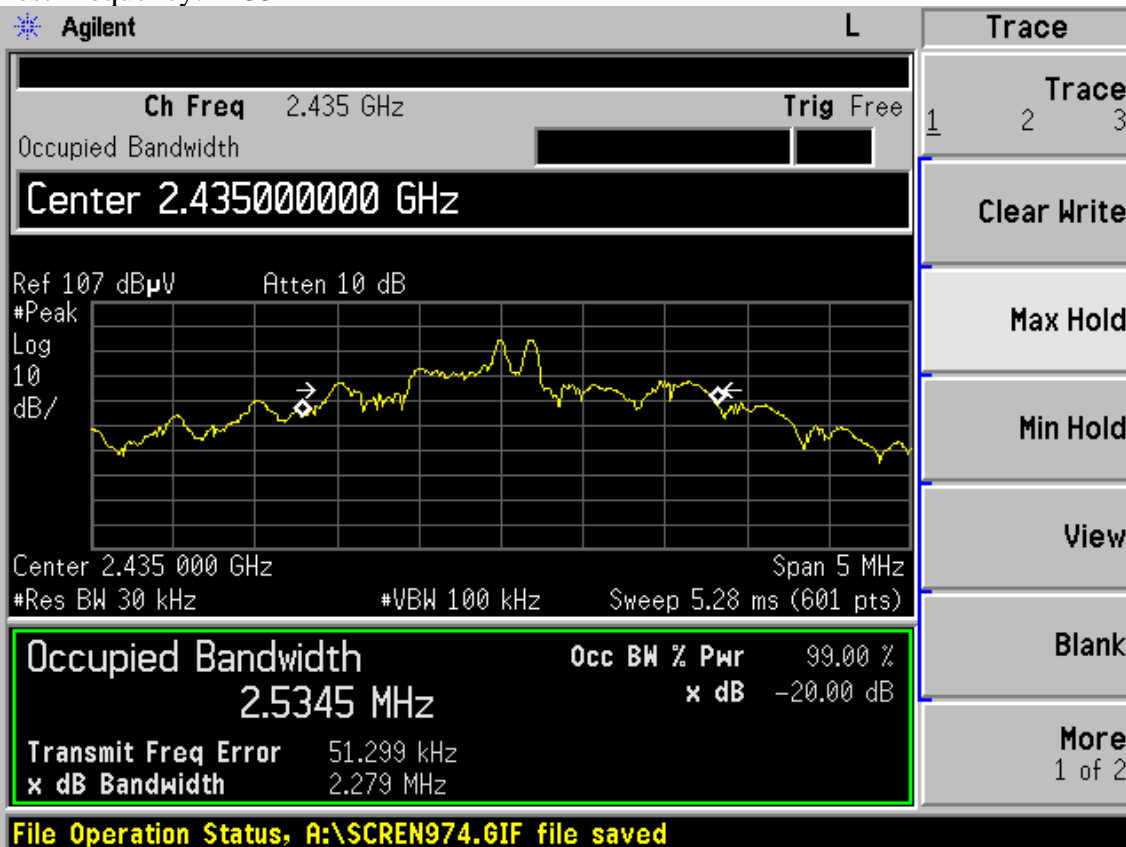



Test Frequency: 2439MHz

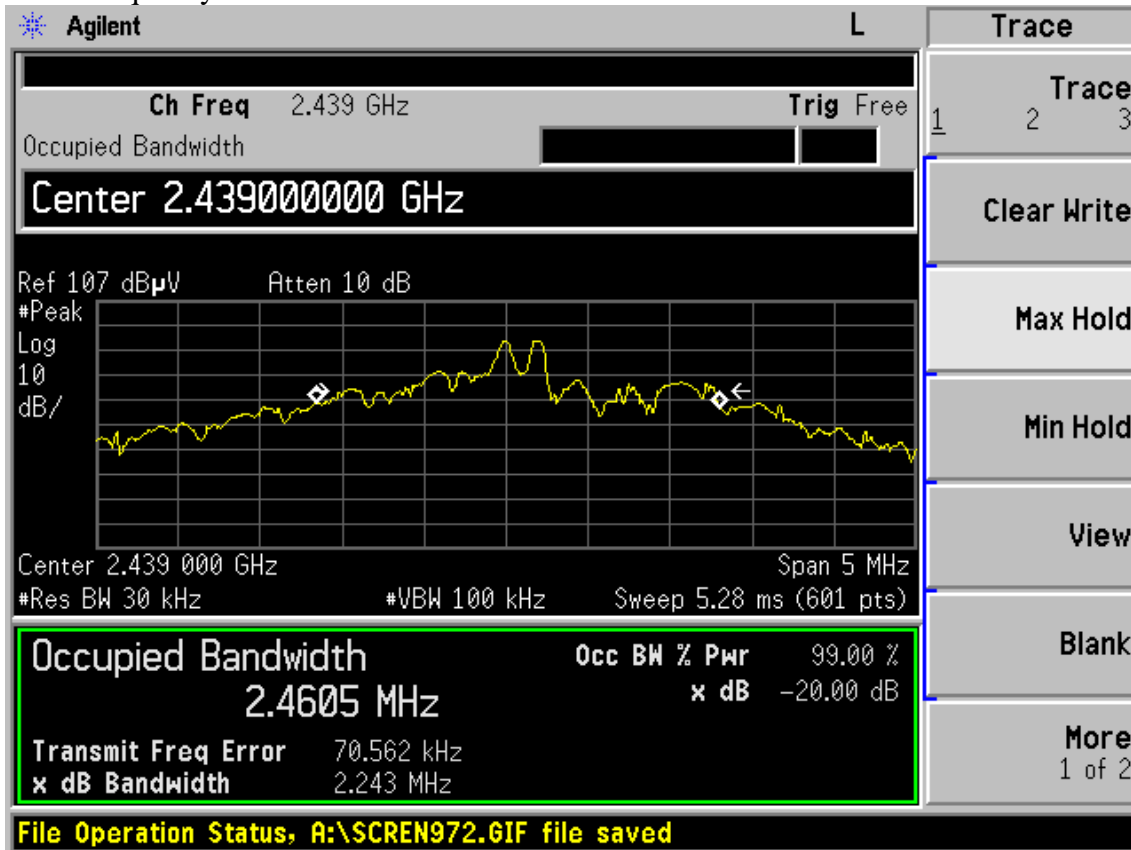

## 7. DEVIATION TO TEST SPECIFICATIONS

[ NONE ]