

MicrOS 410 Installation Guide



ABB Inc.
3055 Orchard Drive
San Jose CA 95134
www.abb.com/tropos
408-331-6800

Part No. 200635-00 Rel A0
2016_06_09

Power and productivity
for a better world™ **ABB**

Copyright Notice

©2003-2016 ABB. All rights reserved. TropOS, TropOS Networks, and PWRP are registered trademarks of ABB. All other brand names, company names, product names, trademarks, and registered trademarks are the property of their respective holder(s). Information contained herein is subject to change without notice. The only warranties for ABB products and services are set forth in the express warranty statements accompanying such products and services. Nothing herein should be construed as constituting an additional warranty. ABB shall not be liable for technical or editorial errors or omissions contained herein.

This product includes technology protected by U.S. Patents 6,704,301; 6,965,575; 7,016,328; 7,031,293; 7,058,021; 7,362,737; 7,376,087; 7,382,778; 7,397,789; 7,450,552; 7,460,489; 7,489,932; 7,499,409; 7,505,426; 7,542,421; 7,551,562; 7,564,781; 7,564,862; 7,580,393; 7,580,705; 7,586,879; 7,649,866; 7,668,137; 7,688,808; 7,689,224; 7,697,504; 7,706,285; 7,720,499; 7,729,278; 7,769,040; 7,843,891; 7,924,749; 7,929,975; 7,957,337; 7,970,394; 7,983,225; 8,031,615; 8,036,130; 8,036,186; 8,054,784; 8,055,759; 8,064,404

FCC Notice to Users and Operators

This device complies with Part 15 of the FCC Rules. Operation is subject to the following two conditions: (1) this device may not cause harmful interference, and (2) this device must accept any interference received, including interference that may cause undesired operation.

This equipment has been tested and found to comply with the limits for a Class B digital device, pursuant to Part 15 of the FCC Rules. These limits are designed to provide reasonable protection against harmful interference when the equipment is operated in a commercial environment. This equipment generates, uses, and can radiate radio frequency energy and, if not installed and used in accordance with the instruction manual, may cause harmful interference to radio communications. Operation of this equipment in a residential area is likely to cause harmful interference, in which case the user will be required to correct the interference at his own expense. If this equipment does cause interference to radio or television reception, which can be determined by turning the equipment off and on, the user is encouraged to correct the interference by using one of the following measures:

- Reorient or relocate the receiving antenna.
- Increase separation between the equipment and receiver.
- Connect the equipment to an outlet on a circuit different from that to which the receiver is connected.
- Consult the dealer or an experienced radio/TV technician.

This Part 15 radio device operates on a non-interference basis with other devices operating at this frequency. Any changes or modification to said product not expressly approved by ABB could void the user's authority to operate this device.

Industry Canada

Notice to users and operators:

This Class B digital apparatus meets all requirements of the Canadian Interference Causing Equipment Regulations. Operation is subject to the following two conditions: (1) this device may not cause harmful interference, and (2) this device must accept any interference received, including interference that may cause undesired operation.

Cet appareillage numérique de la classe B répond à toutes les exigences de l'interférence canadienne causant des règlements d'équipement. L'opération est sujette aux deux conditions suivantes : (1) cet dispositif peut ne pas causer l'interférence nocive, et (2) ce dispositif doit accepter n'importe quelle interférence reçue, y compris l'interférence qui peut causer l'opération peu désirée.

This device has been designed to operate with the antennas listed in [Chapter 4, "Antenna Information."](#) Antennas not included in the chapter or having a gain greater than 12 dBi in the 2.4 GHz band and 19 dBi in the 5.8 GHz band are strictly prohibited for use with this device. The required antenna impedance is 50 ohms.

Operation is subject to the following two conditions:

1. This device may not cause interference, and
2. This device must accept any interference, including interference that may cause undesired operation of the device.

To reduce potential radio interference to other users, the antenna type and its gain should be so chosen that the equivalent isotropically radiated power (EIRP) is not more than that permitted for successful communication.

European Union WEEE Notice

For EU member countries, this symbol means: Do not dispose of this equipment as unsorted municipal waste. This equipment must be collected separately.

The return and collection of this product has not been defined at this time, please contact ABB for return and/or collection.

It is important for users of this equipment to participate in reuse, recycling, and other forms of recovery. The potential effects on the environment and human health as a result of the presence of hazardous substances in electrical and electronic equipment are a waste of natural resources and cause pollution.



STOP!! STOP!! STOP!! STOP!!



READ THIS FIRST!

Important Safety Instructions



The exclamation point within an equilateral triangle is intended to alert the user to the presence of important operating and maintenance (servicing) instructions in the literature accompanying the product.



The lightning flash with an arrowhead symbol within an equilateral triangle is intended to alert the user to the presence of uninsulated “dangerous voltage” within the product’s enclosure that may be of sufficient magnitude to constitute a risk of electric shock to persons.

Caution



Read these instructions.

Keep these instructions.

Heed all warnings.

Follow all instructions.

Do not defeat the safety purpose of the grounding.

Only use attachments/accessories specified by the manufacturer.

Refer all servicing to qualified service personnel. Servicing is required when the apparatus has been damaged in any way, such as power-supply cord or plug is damaged, liquid has been spilled on objects have fallen into the apparatus, the apparatus has been exposed to rain or moisture, does not operate normally, or has been dropped.

Warning



Risk of personal injury or death when installing this device!

There is a risk of personal injury or death if the device antennas come near electric power lines. Carefully read and follow all instructions in this manual. By nature of the installation, you may be exposed to hazardous environments and high voltage. Use caution when installing the outdoor system.



This apparatus must be connected to earth ground.

Do not open the unit — risk of electric shock inside.

Risque d'électrocution. Ne pas ouvrir l'unité.

Caution



You are cautioned that any change or modification not expressly approved in this manual could void your authority to operate this equipment.

Les changements et modifications, non expressément approuvés dans le présent manuel, peuvent entraîner une interdiction d'utiliser cet appareil pour l'utilisateur.



Service

There are no user-serviceable parts inside. All service must be performed by qualified personnel.

Vous ne devez pas réparer les pièces se trouvant à l'intérieur de l'appareil. Les réparations doivent être effectuées uniquement par du personnel qualifié.



The MicrOS 410s are installed in wet, outdoor locations. Make sure closure caps are installed and all cable connections are securely fastened and waterproofed.



Surfaces may become hot. Use caution when accessing the MicrOS 410s.

Contents

- 1 Introduction 10**
- 2 Installing the MicrOS 410 11**
 - Product Summary 12
 - Preparing for Installation 12
 - Installation Hardware and Tools 14
 - Site Planning 14
 - Location Guidelines 15
 - Site Surveys 15
 - Safety 15
 - Mounting Strategies 16
 - Pole and Wall Mounting Instructions 17
 - Metal Pole Mounting 17
 - Wood Pole and Wall Mounting 20
 - Connecting Power and Data Cables 21
 - LED Status Indicator 24
 - Alignment LED 25
 - Safety and Servicing Information 26
 - RF Exposure Information 26
 - Safety Guidelines 27
 - Servicing the MicrOS 410 27
- 3 Product Specifications 28**
- 4 Antenna Information 32**
- 5 Wind Loading Considerations 34**

Figures

- Figure 1 MicrOS 410 Exploded View - Rear 13
- Figure 2 Metal Pole Mounting 18
- Figure 3 Wood Pole and Wall Mounting 20
- Figure 4 Data Port Connection 21
- Figure 5 Routing the Data/Power Cable to the Router 23
- Figure 6 Alignment LED 25
- Figure 7 MicrOS 410 Antenna Patterns 33

Tables

- Table 1 MicrOS 410 Models 12
- Table 2 Exploded View Callouts 13
- Table 3 Metal Pole Mounting Callouts 18
- Table 4 Wood Pole and Wall Mounting Callouts 20
- Table 5 Wired Client Scenarios 21
- Table 6 Ethernet Pin Assignments (Port 1) 23
- Table 7 Serial Pin Assignments 24
- Table 8 LED Indicator States 24
- Table 9 RF Exposure Specifications 26
- Table 10 Physical Specifications 28
- Table 11 Interfaces 30
- Table 12 Protection/Power 30
- Table 13 Certifications, Other 31
- Table 14 Antenna Specifications 32

1 Introduction

The MicrOS 410 is a single-radio, Wi-Fi Bridge that is designed to connect serial or Ethernet clients such as RTUs or PLCs to an ABB TropOS Wi-Fi mesh network.

The MicrOS 410 is designed for general purpose outdoor applications. It functions as a high-power client radio. The MicrOS 410 is equipped with an integrated, directional antenna that provides high gain, but must be aimed at the Wi-Fi device with which it will communicate.

The MicrOS 410 is available in both FCC/Industry Canada and ETSI versions.

It is available in two client-port versions:

- One 10/100Base-T Ethernet port plus serial ports
- Two 10/100Base-T Ethernet ports

This guide describes how to install the MicrOS 410. See the *MicrOS User Guide* for configuration instructions.

2 Installing the MicrOS 410

This guide explains how to install the MicrOS 410 safely and is intended for trained technical professionals. This chapter covers the following topics:

- [“Product Summary”](#) on page 12
- [“Preparing for Installation”](#) on page 12
- [“Mounting Strategies”](#) on page 16
- [“Pole and Wall Mounting Instructions”](#) on page 17
- [“Connecting Power and Data Cables”](#) on page 21
- [“LED Status Indicator”](#) on page 24
- [“Safety and Servicing Information”](#) on page 26

Product Summary

The MicrOS 410 has the following characteristics:

- 802.11b/g/n band, 2400-2483 MHz
- Support for 10/100Base-T Ethernet clients
- Support for RS-232 and RS-485 serial clients
- PoE power input 7-36 VDC

Table 1 lists the MicrOS 410 models.

Table 1 MicrOS 410 Models

Model	Description
M4101060	MicrOS 410 Bridge, one Ethernet port plus one serial port (FCC/IC)
M4101000	MicrOS 410 Bridge, two Ethernet ports (FCC/IC)
M4101062	MicrOS 410 Bridge, one Ethernet port plus one serial port (ETSI)
M4101002	MicrOS 410 Bridge, two Ethernet ports (ETSI)

Preparing for Installation

The MicrOS 410 must be installed by a trained professional, value added reseller, or systems integrator who is familiar with RF planning issues and regulatory limits defined by the governing body of the country in which the unit will be installed. This section explains how to prepare the installation site.

An exploded view of the MicrOS 410 assembly is shown in [Figure 1](#).



Note

Operating the unit with non-qualified antennas is a violation of U.S. FCC Rules Part 15.203(c), Code of Federal Regulations, Title 47.

Figure 1 MicrOS 410 Exploded View - Rear

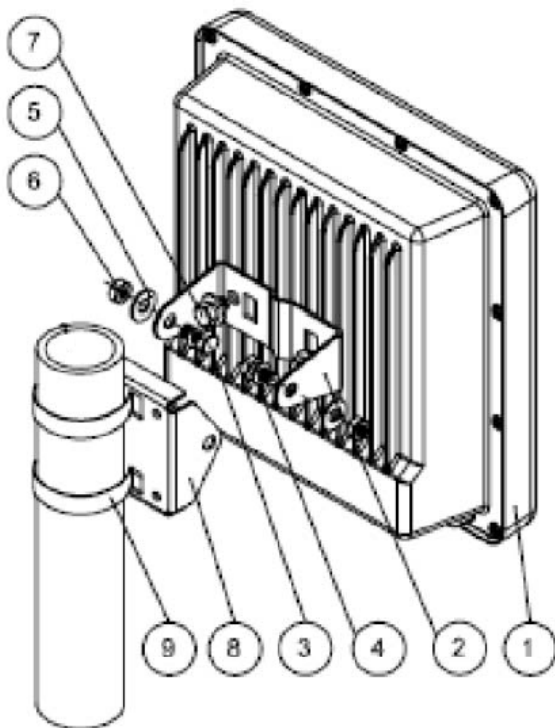

Table 2 Exploded View Callouts

Item	Description
1	MicrOS 410 Unit
2	Mounting bracket
3	M8 x 16mm screw (2 pieces)
4	M8 split washer (2 pieces)
5	M8 flat washer (2 pieces)
6	M8 nut (2 pieces)
7	M8 x 12mm screw (2pieces)
8	Mounting bracket
9	Hose clamp, 5" (2 pieces)

Installation Hardware and Tools

The following installation accessories are included in the shipping package (see [Figure 1](#)):

- One bracket for the MicrOS 410
- Two 8mm x 16mm screws
- Two 8mm lock washers
- Two 8mm plain washers
- Two 8mm nuts
- Two 8mm x 12mm screws
- One pole mounting bracket
- Two hose clamps, 2" to 5" application
- Four anchor screws (for wall-mount applications)
- Four plastic anchors (for wall-mount applications)

You must supply the following tools:

- Level
- 5/16-inch nut driver
- 1/4-inch flat blade screwdriver
- RJ-45 crimping tool
- Tower mounting only: stainless or galvanized steel pipe and 1/2-inch or 5/8-inch nuts, bolts, and washers to connect to the tower arm.
- Wood pole mounting only: one 1/4-inch diameter, 3 1/2-inch long lag bolt

Site Planning

To ensure safe and durable wiring, installation must follow appropriate electrical and building codes. Follow the National Electrical Code (NEC) requirements, unless local codes in your area take precedence over the NEC code.

The following distance limits apply to installations that have 10/100 Base-T Category 5 network cables attached to the MicrOS 410:

- 300 feet maximum between devices for 100BaseT operation
- 500 feet maximum for 10BaseT operation.

The Ethernet duplex and speed setting is configurable.



Note

National Electrical Codes (NEC) Article 800 requires the use of Agency Listed (UL/CSA/TUV) Building Entrance Protector for all power and data communications cables entering a building. The NEC intends by Article 800 to protect the building and occupants from fires caused by transient voltage and current surges.

**Note**

Ethernet data cable installations having lengths greater than 140 feet in the outdoor environment must use a UL497 approved (UL/CSA/TUV Listed) primary protection device at the building entrance. Ethernet data cable installations having lengths less than 140 feet in the outdoor environment may use a UL497A (UL/CSA/TUV Listed) secondary protection device at the building entrance. TropOS Data Protection Device and Network Protection Units are UL497A secondary protection devices.

Location Guidelines

MicrOS 410 devices are radio devices and therefore susceptible to interference that can reduce throughput and range. Install the unit in an area where trees, buildings, and large steel structures do not obstruct radio signals to and from the antenna. Direct line-of-sight operation is best.

Site Surveys

Due to variations in component configuration, placement, and physical environment, each installation is unique. Before installing the MicrOS 410, perform a site survey to determine the optimum placement of units for maximum range, coverage, and network performance. Consider the following factors when performing a site survey:

- Data rates—Sensitivity and range are inversely proportional to data bit rates. The maximum radio range is achieved at the lowest workable data rate. A decrease in receiver threshold sensitivity occurs as radio data rate increases.
- Antenna orientation—The MicrOS 410 uses a directional antenna that must be aimed at its Wi-Fi router.
- Physical environment—Clear or open areas provide better radio range than closed or filled areas. The less cluttered the operating environment, the greater the range.
- Obstructions—A physical obstruction, such as a building or tree, can block or hinder communication. Avoid locating the MicrOS 410 in a location where there is an obstruction between sending and receiving devices.
- Building materials—Radio penetration is influenced by the building material used in construction. For example, drywall construction permits greater range than concrete blocks.

Safety

Installing the MicrOS 410 can pose a serious hazard. Be sure to take precautions to avoid the following:

- Exposure to high voltage lines during installation
- Falls when working at heights or with ladders
- Injuries from dropping tools and equipment
- Contact with AC wiring

Mounting Strategies

When choosing mounting locations, consider the available mounting structures and antenna clearance. The unit should always be mounted with the top horizontal and level.

It is usually best to attach ground and data cables to the unit prior to mounting. Before mounting the unit, review the wiring instructions in [“Connecting Power and Data Cables”](#) on page 21 to determine the best strategy for the selected location.

**Note**

To eliminate potential interference from the mounting structure, the MicrOS 410 should be mounted with at least 4 feet of clearance around the antenna radome.

Pole and Wall Mounting Instructions

This section explains how to mount the MicrOS 410 on a pole or wall. It is best to mount the unit to aluminum or galvanized steel structures. The mounting brackets are designed to pierce any oxidation layers that are on the outside of the pole, thereby assuring good quality connection to the grounded structure.

Metal Pole Mounting

[Figure 2](#) illustrates proper mounting for an outdoor metal pole.

**Note**

The antenna radome must be clear of obstruction.

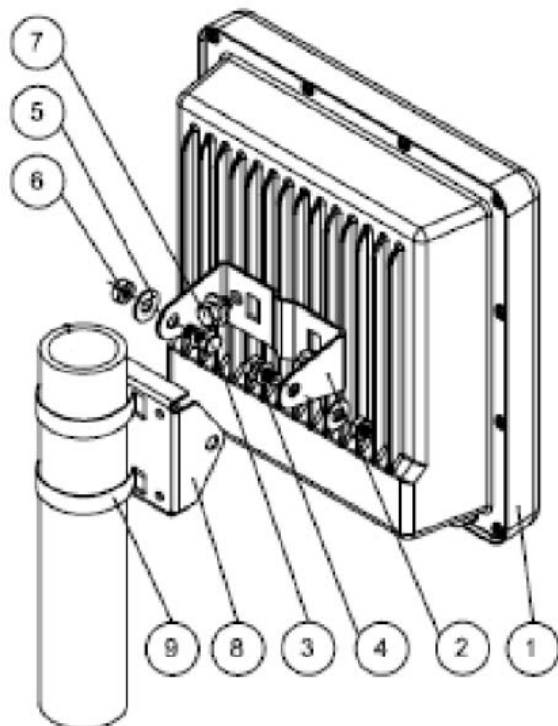
Figure 2 Metal Pole Mounting**Table 3 Metal Pole Mounting Callouts**

Item	Description
1	MicrOS 410 Unit
2	Mounting bracket
3	M8 x 16mm screw (2 pieces)
4	M8 split washer (2 pieces)
5	M8 flat washer (2 pieces)
6	M8 nut (2 pieces)
7	M8 x 12mm screw (2pieces)
8	Mounting bracket
9	Hose clamp, 5" (2 pieces)

Mount the MicrOS 410 on a metal pole

1. Select a mounting location. You can attach the MicrOS 410 to any pipe or pole with diameter between 2 inches and 5 inches.
2. Slip the flat portion of the clamp under the inner slot of the pole bracket.
3. Use the clamp to attach the pole bracket to the pole, making sure that it is level. Depending upon the diameter of the pole, you may need to use a single small clamp, single large clamp, or pair of large clamps joined together to reach around the pole.
4. Attach the MicrOS M-type bracket to the MicrOS 410 as shown in [Figure 2](#).
5. Attach the mounting bracket of the unit to the pole bracket.
 - Insert one screw through the hole at the top of the mounting bracket to the hole at the top of the pole bracket.
 - Insert the other screw through the curved slot track in the mounting bracket to the hole in the middle of the pole bracket just above the clamp slot.
6. Level the mounting bracket by rotating the unit along the curved slot tracks. Tighten the screws.

To continue installing the MicrOS 410, see [“Connecting Power and Data Cables”](#) on page 21.

Wood Pole and Wall Mounting

For wood pole and wall mounting, the antenna radome must be clear of obstruction.

Figure 3 Wood Pole and Wall Mounting

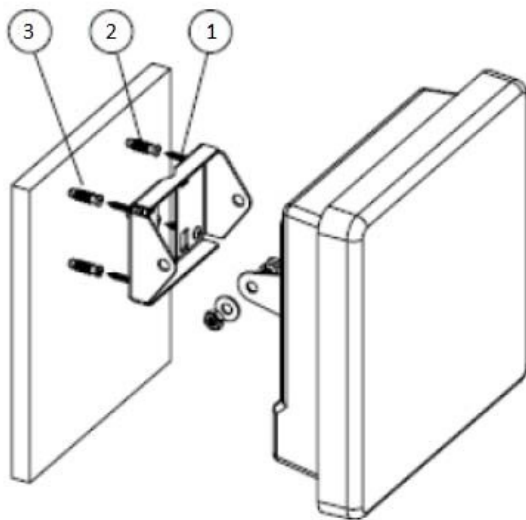

Table 4 Wood Pole and Wall Mounting Callouts

Item	Description
1	Anchor screws (4 pieces)
2	Plastic anchor (4 pieces)
3	Wall

Mount the MicroS 410 on a wood pole or wall

1. Select a mounting location. You can attach the MicroS 410 to any outdoor wood pole of diameter at least 1 inch.
2. Attach the pole bracket to the pole by threading a 1/4-inch lag bolt through the hole in the clamp slot to the pole. Make sure that the bracket is level. Alternatively, a hole can be drilled through the pole and a 1/4-inch bolt of sufficient length can be used with a washer and nut.
3. Attach the MicroS 410 with mounting bracket to the pole bracket as shown in the figure. Make sure the unit is level.
 - Insert one screw through the hole at the top of the mounting bracket to the hole at the top of the pole bracket.
 - Insert the other screw through the curved slot track in the mounting bracket to the hole in the middle of the pole bracket just above the clamp slot.

Connecting Power and Data Cables

The MicrOS 410 supports wired clients connected to either or both Ethernet or serial interfaces. The MicrOS 410 is equipped with two RJ-45 connectors that are used for Ethernet and serial interfaces and for powering the MicrOS 410 through the use of watertight glands.

Figure 4 Data Port Connection

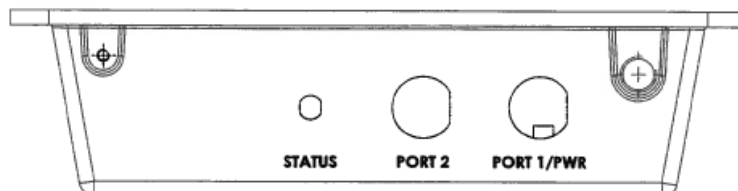

Determine whether you have a MicrOS 410 with two Ethernet ports or one Ethernet port and one serial port (see [Table 1](#)).

Depending on the specific application, the use of one or both connectors may be required.

If you have a MicrOS 410 equipped with two Ethernet ports, either or both ports can be used for Ethernet clients. Power must be applied on port 1.

[Table 5](#) describes the possible wired client scenarios for a MicrOS 410 equipped with serial interfaces.

Table 5 Wired Client Scenarios

Wired Client Scenario	Recommended wiring
One Ethernet client	<ul style="list-style-type: none"> • Connect the Ethernet client to Port 1 (Ethernet) on the MicrOS 410 • Provide power to the MicrOS 410 on Port 1
One Ethernet client One RS-232 serial client	<ul style="list-style-type: none"> • Connect the Ethernet client to Port 1 (Ethernet) on the MicrOS 410 • Connect the RS-232 serial client to Port 2 (serial) on the MicrOS 410 • Provide power to the MicrOS 410 on Port 1
One Ethernet client Two RS-232 serial clients	<ul style="list-style-type: none"> • Connect the Ethernet client to Port 1 (Ethernet) on the MicrOS 410 • Connect the RS-232 serial clients to Port 2 (serial) on the MicrOS 410 • Provide power to the MicrOS 410 on Port 1
One Ethernet client One RS-485 serial client	<ul style="list-style-type: none"> • Connect the Ethernet client to Port 1 (Ethernet) on the MicrOS 410 • Connect the RS-485 serial client to Port 2 (serial) on the MicrOS 410 • Provide power to the MicrOS 410 on Port 1
One Ethernet client One RS-232 serial client One RS-485 serial client	<ul style="list-style-type: none"> • Connect the Ethernet client to Port 1 (Ethernet) on the MicrOS 410 • Connect the RS-232 and RS-485 clients to Port 2 • Provide power to the MicrOS 410 on Port 1

Table 5 Wired Client Scenarios (*continued*)

Wired Client Scenario	Recommended wiring
One RS-232 serial client	<ul style="list-style-type: none"> Connect the wired client to Port 2 (serial) on the MicroS 410 Provide power to the MicroS 410 on Port 1
Two RS-232 serial clients	<ul style="list-style-type: none"> Connect the RS-232 serial clients to Port 2 (serial) on the MicroS 410 Provide power to the MicroS 410 on Port 1
One RS-232 serial client One RS-485 serial client	<ul style="list-style-type: none"> Connect the RS-232 and RS-485 clients to Port 2 (serial) on the MicroS 410 Provide power to the MicroS 410 on Port 1

When the configuration is determined, use the following sections as guidelines for proper cabling.

**Note**

The MicroS 410 is shipped pre-configured. For post-installation changes in configuration, you can communicate with the unit by way of its wireless connection. For more information, see the Tropos Networks Configuration Guide.

**Note**

Only use shielded Cat5 cable rated for outdoor use. For protection against risk of fire, electrical hazard and to ensure the reliable operation of this equipment, the shields of the Cat5 cable must be properly terminated and bonded to the unit and to the protective earth (PE) at the building entrance.

**Note**

National Electrical Codes (NEC) Article 800 requires the use of Agency Listed (UL/CSA) Building Entrance Protector for all power and communications cables entering a building. The NEC intends by Article 800 to protect the building and occupants from fires caused by transient voltage and current surges.

**Warning**

DC voltage may be present on RJ45 pins 4,5 (+) and 7,8 (-).

**Attention**

Une tension continue peut être présente sur les broches RJ45 4, 5 (+) et 7, 8 (-).

**Note**

This is not a mid-span powered device. Never attempt to daisy-chain Power Over Ethernet devices.

Connecting the Ethernet cable

1. Have the Ethernet data cable, nut, rubber boots, and cable gland available.
2. Remove the cable gland from the bottom of the MicrOS 410. For power and Ethernet connectivity, use Port 1.
3. Press the tab on the RJ45 connector down as you push the cable through the nut. Make sure that the orientation is consistent with [Figure](#) .
4. Separate the rubber boot as needed and slide the connector through the boot. Use the boot with the smaller diameter opening, unless the cable is too wide to permit the boot to close completely. Use only one boot.
5. Slide the cable through the cable gland, as shown in [Figure](#) .

Figure 5 Routing the Data/Power Cable to the Router

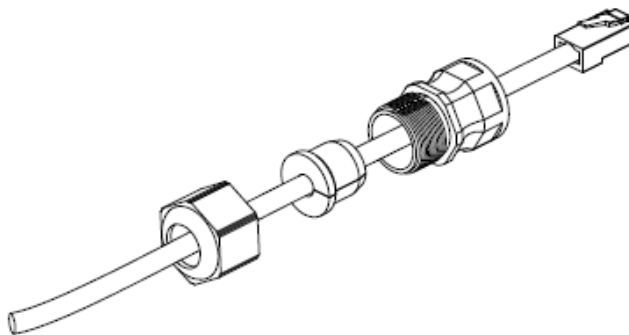

Table 6 Ethernet Pin Assignments (Port 1)

Pin	Assignment
1	TX+
2	TX-
3	RX+
4	Power+
5	Power+
6	RX-
7	Power-
8	Power-

Port 2 has the same pin assignments as port 1 except that power is not supported on Port 2, so pins 4, 5, 7 and 8 are not used.

Connecting the Serial Cable

1. Have the Ethernet data cable, nut, rubber boots, and cable gland available.
2. Remove the cable gland from the bottom of the MicrOS 410. For power and Ethernet connectivity, use Port 1.
3. Press the tab on the RJ45 connector down as you push the cable through the nut. Make sure that the orientation is consistent with [Figure 5](#).
4. Separate the rubber boot as needed and slide the connector through the boot. Use the boot with the smaller diameter opening, unless the cable is too wide to permit the boot to close completely. Use only one boot.
5. Slide the cable through the cable gland.

Table 7 Serial Pin Assignments

Pin	Option 1 (one serial port)	Option 2 (two serial ports)
1	RS232 TX or RS485 TXRX -	RS232 (port 2) TX or RS485 TXRX -
2	GND	GND
3	RS232 RX or RS485 TXRX +	RS232 (port 2) RX or RS485 TXRX +
4	not used	not used
5	not used	RS232 (port 1) RX
6	not used	RS232 (port 1) TX
7	not used	not used
8	not used	not used



Note

When using one RS-232 port, as shown in Option 1 in [Table 7](#) (pin 1=TX, pin 3=RX), the Configuration Utility for the serial port should be set up for port 2 (for more information, see the MicrOS 410 User Guide).

LED Status Indicator

The MicrOS 410 is equipped with LED status indicator. The LED indicator has three states, as shown in [Table 8](#).

Table 8 LED Indicator States

State	Description
Off	The unit has no power or is not operating.

Table 8 LED Indicator States

State	Description
Flashing	The unit has power but is not ready. It may be in the process of associating with the network or it may not be able to associate with a network.
On	The unit is associated with the network and operating properly.

Alignment LED

The MicroS 410 has an alignment LED on the back of the unit. This LED helps the installer optimally aim the MicroS 410 at the Wi-Fi router to which it will communicate. The MicroS 410 directional antenna has a 3dB beam width of 30° and a 6dB beam width of 35°. This wide range makes the unit easy to align. The alignment LED is useful in getting maximum performance.

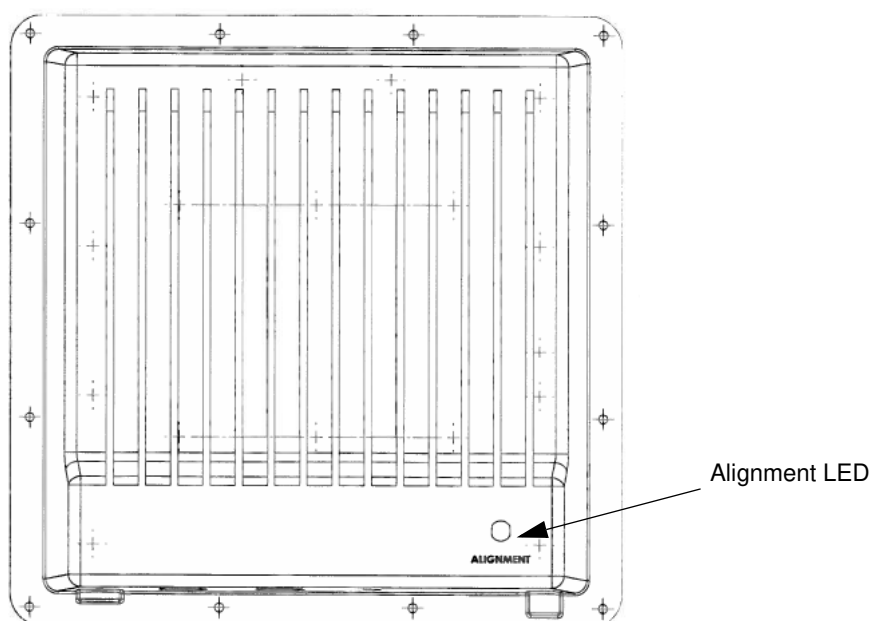
Figure 6 Alignment LED

The MicroS 412 must first associate with a router before the alignment LED can be used. Use the following procedure to properly align the MicroS 410:

1. Install the MicroS 410 and aim it in the general direction of the router you want it to associate to.
2. Move the MicroS 410, if necessary, until it associates with the router. See [Table 8](#) (the Status LED must be solid green).

When the MicrOS 410 associates, the alignment LED will begin to flash. The alignment LED will flash faster as signal strength increases and slower as signal strength decreases.

3. Rotate the MicrOS 410 on the pole until the alignment LED is blinking as fast as possible.

The alignment LED will stop blinking after 15 minutes. If the alignment LED is needed after 15 minutes, turn it on using the configuration interface for the unit, or power the unit off and on again.

Safety and Servicing Information

This section contains safety and servicing information.

RF Exposure Information

The Federal Communications Commission (FCC) with its action in ET Docket 96-8 has adopted a safety standard for human exposure to RF electromagnetic energy emitted by FCC certified equipment. The MicrOS 410 meets the uncontrolled environmental limits found in OET-65 and ANSI C95.1, 1991. Proper operation of this device according to the instructions found in this manual and the hardware and software guides results in user exposure that is substantially below the FCC recommended limits.

In order to meet the human RF exposure limits required by FCC and Industry Canada, the installer shall insure separation between transmitter antennas. All persons should maintain a minimum distance from the unit as specified in [Table 9](#).

Table 9 RF Exposure Specifications

Model	Radios, RF Band	Antennas	Maximum EIRP	Minimum Distance
MicrOS 410	Single 2.4 GHz	External	2.4 GHz EIRP, 36 dBm	25 cm (9.8 in)



Warning

It is illegal to modify the construction of this product. Modifying the operating frequency or enhancing the transmit output power through the use of external amplifiers or other equipment is specifically disallowed by the “Telecommunications Act.”



Warning

This device is for outdoor or indoor use with conditions that no harmful interference to authorized radio stations results from the operation of this device. This device shall not influence aircraft security and/or interfere with legal communications as defined in the “Telecommunications Act.” If this device is found to cause interference, the operator of this equipment shall cease operating this device immediately until no interference is achieved.

Safety Guidelines

Follow these guidelines to ensure safe operation of the MicrOS 410:

- Do not hold any component containing a radio such that the antenna is very close to or touching any exposed parts of the body, especially the face or eyes, while transmitting.
- Use in specific environments:
 - Do not operate a portable transmitter near unshielded blasting caps or in an explosive environment unless it is a type especially qualified for such use.
 - The use of wireless devices in hazardous locations is limited to the constraints posed by the safety directors of such environments.
 - The use of wireless devices on airplanes is governed by the Federal Aviation Administration (FAA).
 - The use of wireless devices in hospitals is restricted to the limits set forth by each hospital.

Servicing the MicrOS 410

The MicrOS 410 has no user serviceable parts inside. For any service-related issues, contact Customer Support (tropos.support@nam.abb.com).

3 Product Specifications

The tables in this chapter contain specifications for the MicrOS 410:

- [“Physical Specifications”](#) on page 28
- [“Interfaces”](#) on page 30
- [“Protection/Power”](#) on page 30
- [“Certifications, Other”](#) on page 31

Table 10 Physical Specifications

Specification	Value
Physical Dimensions (without mounting brackets)	
Inches	Height: 9.85" (25 cm) Width: 9.85" (25 cm) Depth: 3.46" (8.8 cm)
Weight (with mounting brackets and antennas)	
Weight	4 lbs (1.82 kg)
Mounting	
Mounting Pole Diameter	1" to 5"
Temperature	
Operating Range	Min: -40° C (-40° F) Max: 75° C (167° F)
Storage Range	Min: -40° C (-40° F) Max: 85° C (-185° F)
Weather	
Weather Rating	IP67 weathertight
Wind Survivability	> 165 mph
Wind Loading (165 mph)	< 210 newtons
Projected Area	97 sq. in.
Corrosion Resistance	ASTM B117 salt fog rust resistance compliant

Table 10 Physical Specifications (*continued*)

Specification	Value
Color	
Color	Gray
Shock and Vibration	
Operational:	ETSI 300-19-2-4 Specification T41.E, class 4M3
Transportation:	ISTA 2A
Status Lamp	
LED Indicator	Off: No power Flashing: Power on, system not ready On: System ready

Table 11 Interfaces

Specification	Value
Ethernet Interface	
IEEE 802.3 10/100BaseT	<ul style="list-style-type: none"> • Auto sensing • Maximum Distance (ft): 550 (10BaseT Duplex Setting) 300 (100BaseT Duplex Setting) • RJ45 connector
Serial Interface	
RS-232	<ul style="list-style-type: none"> • Auto sensing • Maximum Distance 550 ft • RJ45 connector
RS-485	<ul style="list-style-type: none"> • Auto sensing • Maximum Distance 500 ft • RJ45 connector
802.11b/g/n Wireless Interface	
Standard	IEEE 802.11b/g/n Wi-Fi
Frequency Range	2400 to 2483 MHz ISM Band (11 channels) FCC Part 15 2400 to 2483 MHz ISM Band (13 channels) ETSI
Modulation	802.11g/n - OFDM (64-QAM, 16-QAM, QPSK, BPSK) 802.11b - DSSS (DBPSK, DQPSK, CCK)
Rx Sensitivity	-97dBm @ 1 Mbps -96dBm @ 6 Mbps
Tx Power	FCC/IC 20.0dBm -35dBm (EIRP) set in 1dB units ETSI/EU 5-20dBm set in 1dB units

Table 12 Protection/Power

Specification	Value
Antenna Protection	<= 0.5μJ for 3kA @ 8/20μS Waveform EN61000-4-2 Level 4 ESD Immunity EN61000-4-5 Level 4 Surge Immunity
Data Port Protection	EN61000-4-2 Level 4 ESD Immunity EN61000-4-5 Level 4 Surge Immunity
Power	
Power Input	Power input: PoE (7-36 VDC)
Power Consumption	3 W typical

Table 13 Certifications, Other

Regulatory Domain	Specification
U.S.	CFR 47 FCC Part 90 CFR 47 FCC Part 15.C; Class B UL579/IEC 60529 IP67 Rated for Outdoor Use ISTA 2A
Canada	Industry Canada RSS210

4 Antenna Information

This chapter provides information on the MicrOS 410 antennas.

Table 14 Antenna Specifications

Specification	Description
Frequency range	2400 – 2500MHz
Gain	13dBi
VSWR	2:1 Max
Polarization	Linear \pm 45°
Horizontal beam width	30° (3dB); 35° (6dB)
Vertical beam width	35° (3dB); 45° (6dB)
Side lobes level	-10dB Max
Front to back ratio	-30dB Max
Isolation	20dB

Antenna patterns are shown in [Figure 7](#).

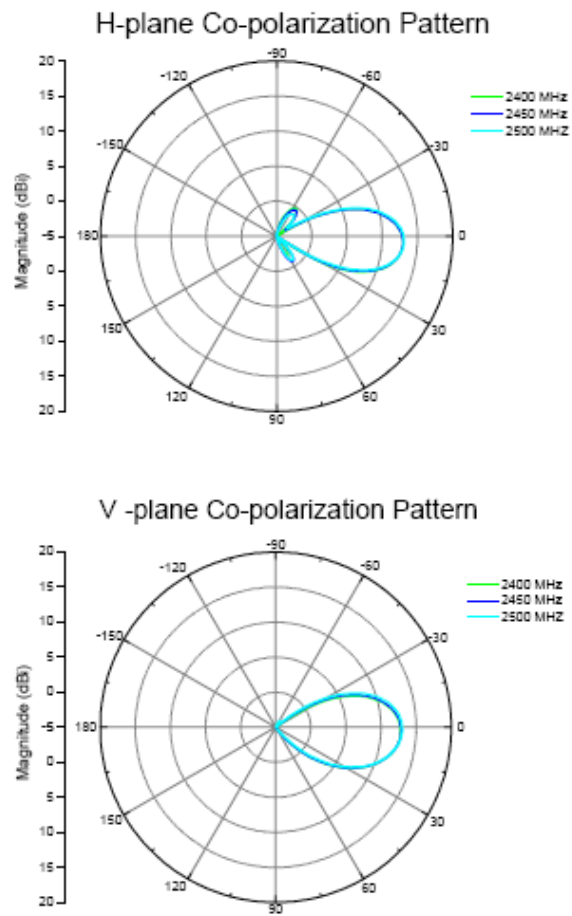
Figure 7 **MicrOS 410 Antenna Patterns**

5 Wind Loading Considerations

The American Association of State Highway and Transportation Officials (AASHTO) standards manual, “Standard Specifications for Structural Supports for Signs, Luminaires and Traffic Signals,” governs most structural support issues related to traffic lighting and controls. Many state and city public works departments site the AASHTO standard as the guide for their requirements. Local municipalities in coastal states, which experience frequent hurricanes, etc., may have exceptions to the AASHTO standard that require higher design limits for wind velocity or dead load.

Numerous pole and mast arm assemblies are used for traffic controls and traffic lighting. Each assembly and installation is unique and worthy of an evaluation of the static and dynamic load bearing capabilities; however, in most cases, the assembly will include a pole with a single 6', 9' or 12' mast arm holding a single luminaire. Many of these mast arms are typically designed to hold hundreds of pounds of static load and to carry several square meters of sail area in 80mph winds. The typical mast arm is capable of supporting a single traffic control (typically weighing around 160 lbs) and a single traffic sign (typically presenting a few square meters of sail area). A single luminaire typically weighs about 60 lbs and presents about 3 square feet of sail area.



Note

Each assembly and installation is unique and worthy of an evaluation of the static and dynamic load bearing capabilities. It is your responsibility to evaluate the load bearing capabilities of the structure.

The router weighs approximately 4 lbs, including all mounting hardware. The router can be mounted to the pole portion of the streetlight or to the mast arm portion.

When the router is mounted to the pole or mast arm, most of the unit is hidden by the pole or mast arm and therefore presents minimal additional sail area to the structure. When the router is mounted to the pole portion of the structure, the sail area of the router is approximately 1 square foot. Pole manufacturers have advised ABB that small communications devices do not present any significant static or dynamic load to these structures.