

FCC Radio Test Report

FCC ID: P96WF71RL

Report No. : TB-FCC124653
Applicant : HUIZHOU TCL KING HIGH FREQUENCY ELECTRONIC
CO., LTD

Equipment Under Test (EUT)

EUT Name : WIFI MODULE
Model No. : WF71RL1500C
Serial No. : N/A
Brand Name : TCL
Receipt Date : 2012-08-13
Test Date : 2012-08-14 to 2012-08-22
Issue Date : 2012-08-24
Standards : FCC Part 15, Subpart C (15.247:2011)
Test Method : ANSI C63.4:2003
Conclusions : **PASS**

In the configuration tested, the EUT complied with the standards specified above,
The EUT technically complies with the FCC requirements

Test/Witness Engineer : *Roy Lai*

Approved & Authorized : *Sally Wong*

This report details the results of the testing carried out on one sample. The results contained in this test report do not relate to other samples of the same product. The manufacturer should ensure that all products in series production are in conformity with the product sample detailed in the report.

Contents

CONTENTS.....	2
1. GENERAL INFORMATION ABOUT EUT	4
1.1 Client Information.....	4
1.2 General Description of EUT (Equipment Under Test)	4
1.3 Block Diagram Showing the Configuration of System Tested.....	5
1.4 Description of Support Units	5
1.5 Description of Test Mode.....	5
1.6 Description of Test Software Setting	6
1.7 Test Facility.....	7
2. TEST SUMMARY	8
3. CONDUCTED EMISSION TEST	9
3.1 Test Standard and Limit.....	9
3.2 Test Setup.....	9
3.3 Test Procedure.....	9
3.4 Test Equipment Used.....	10
3.5 EUT Operating Mode	10
3.6 Test Data.....	10
4. RADIATED EMISSION TEST	13
4.1 Test Standard and Limit.....	13
4.2 Test Setup.....	14
4.3 Test Procedure.....	15
4.4 EUT Operating Condition	15
4.5 Test Equipment	16
4.6 Test Data.....	16
5. RESTRICTED BANDS REQUIREMENT	30
5.1 Test Standard and Limit.....	30
5.2 Test Setup.....	30
5.3 Test Procedure.....	30
5.4 EUT Operating Condition	31
5.5 Test Equipment	31
5.6 Test Data.....	31
6. BANDWIDTH TEST	40
6.1 Test Standard and Limit.....	40
6.2 Test Setup.....	40
6.3 Test Procedure.....	40
6.4 EUT Operating Condition	40
6.5 Test Equipment	40
6.6 Test Data.....	41
7. PEAK OUTPUT POWER TEST.....	49

7.1 Test Standard and Limit.....	49
7.2 Test Setup.....	49
7.3 Test Procedure.....	49
7.4 EUT Operating Condition	49
7.5 Test Equipment	49
7.6 Test Data.....	49
8. POWER SPECTRAL DENSITY TEST	58
8.1 Test Standard and Limit.....	58
8.2 Test Setup.....	58
8.3 Test Procedure.....	58
8.4 EUT Operating Condition	58
8.5 Test Equipment	58
8.6 Test Data.....	58
9. ANTENNA CONDUCTED SPURIOUS EMISSION	67
9.1 Test Standard and Limit.....	67
9.2 Test Setup.....	67
9.3 Test Procedure.....	67
9.4 EUT Operating Condition	68
9.5 Test Equipment	68
9.6 Test Data.....	68
10. ANTENNA REQUIREMENT.....	82
10.1 Standard Requirement.....	82
10.2 Antenna Connected Construction	82
10.2 Result.....	82

1. General Information About EUT

1.1 Client Information

Applicant	:	HUIZHOU TCL KING HIGH FRENQUENCY ELECTRONIC CO., LTD
Address	:	HUA YU RD., NO.75, ZHONGKAI HIGH-TECH DEVELOPMENT AREA, HUIZHOU, CHINA
Manufacturer	:	HUIZHOU TCL KING HIGH FRENQUENCY ELECTRONIC CO., LTD
Address	:	HUA YU RD., NO.75, ZHONGKAI HIGH-TECH DEVELOPMENT AREA, HUIZHOU, CHINA

1.2 General Description of EUT (Equipment Under Test)

EUT Name	:	WIFI MODULE
Models No.	:	WF71RL1500C
Model Difference	:	N/A
Product Description	:	Operation Frequency: 802.11b/g/n(HT20): 2412MHz~2462MHz 802.11n(HT40):2422MHz~2452MHz
	:	Number of Channel: 802.11b/g/n(HT20):11 channels 802.11n(HT40):7 channels see note(3)
	:	Out Power: 802.11b: 17.93 dBm 802.11g: 14.98 dBm 802.11n (HT20): 13.99 dBm 802.11n(HT40): 13.37 dBm
	:	Antenna Gain: 1 dBi (Printed Antenna)
	:	Modulation Type: 802.11b: DSSS (CCK, QPSK, BPSK) 802.11g: OFDM 802.11n: OFDM
	:	Bit Rate of Transmitter: 802.11b:11/5.5/2/1 Mbps 802.11g:54/48/36/24/18/12/9/6 Mbps 802.11n:up to 150Mbps
Power Supply	:	DC Voltage supplied from PC System.
Power Rating	:	DC 3.3V by USB adapter from PC System.
Connecting I/O Port(S)	:	Please refer to the User's Manual

Note:

- (1) This Test Report is FCC Part 15.247 for 802.11b/g/n, the test procedure follows the FCC KDB 558074.
- (2) For a more detailed features description, please refer to the manufacturer's specifications or

the User's Manual.

(3) Channel List:

CH 01~CH 11 for 802.11b/g/n(20M) and CH 03~CH 09 for 802.11n(40M)

Channel	Frequency (MHz)	Channel	Frequency (MHz)	Channel	Frequency (MHz)
01	2412	05	2432	09	2452
02	2417	06	2437	10	2457
03	2422	07	2442	11	2462
04	2427	08	2447		

1.3 Block Diagram Showing the Configuration of System Tested

TX Mode

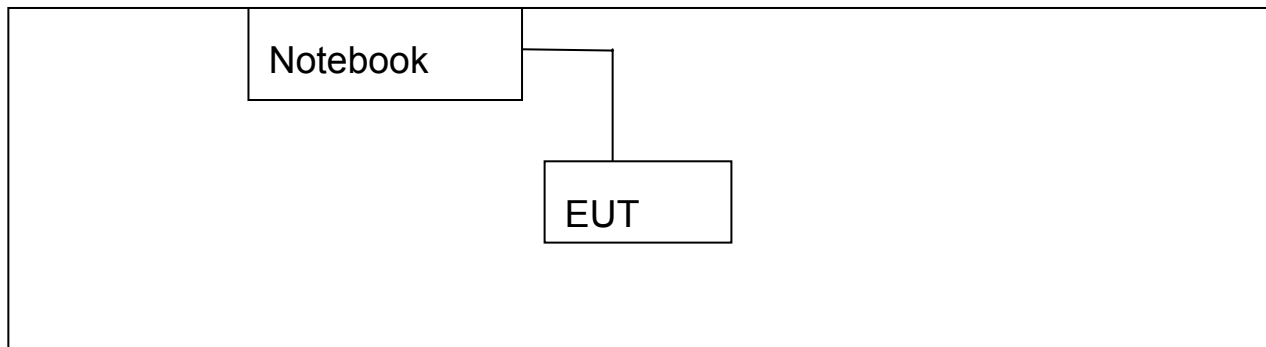

1.4 Description of Support Units

Name	Model	S/N	Manufacturer	Used “√”
Notebook	B470A2450	VNF3G06957	Lenovo	√

1.5 Description of Test Mode

To investigate the maximum EMI emission characteristics generates from EUT, the test system was pre-scanning tested base on the consideration of following EUT operation mode or test configuration mode which possible have effect on EMI emission level. Each of these EUT operation mode(s) or test configuration mode(s) mentioned follow was evaluated respectively.

For Conducted Test	
Final Test Mode	Description
Mode 1	TX Mode (B Mode)

For Radiated Test

Final Test Mode	Description
Mode 2	TX Mode B Mode Channel 01/06/11
Mode 3	TX Mode G Mode Channel 01/06/11
Mode 4	TX Mode N(HT20) Mode Channel 01/06/11
Mode 5	TX Mode N(HT40) Mode Channel 03/06/09

Note:

- (1) For all test, we have verified the construction and function in typical operation. And all the test modes were carried out with the EUT in transmitting operation in maximum power with all kinds of data rate.

According to ANSI C63.4 standards, the measurements are performed at the highest, middle, lowest available channels, and the worst case data rate as follows:

- 802.11b Mode: CCK (1 Mbps)
- 802.11g Mode: OFDM (6 Mbps)
- 802.11n (HT20) Mode: OFDM (6.5 Mbps)
- 802.11n (HT40) Mode: OFDM (13.0 Mbps)

- (2) During the testing procedure, the continuously transmitting with the maximum power mode was programmed by the customer.
- (3) The EUT is considered a mobile unit; in normal use it was positioned on X-plane. The worst case was found positioned on X-plane. Therefore only the test data of this X-plane was used for radiated emission measurement test.

1.6 Description of Test Software Setting

During testing channel & Power controlling software provided by the customer was used to control the operating channel as well as the output power level. The RF output power selection is for the setting of RF output power expected by the customer and is going to be fixed on the firmware of the final end product power parameters of WLAN.

Test Software Version	Test Program: FCC Test.exe		
	2412 MHz	2437 MHz	2462 MHz
Frequency			
IEEE 802.11b DSSS	15	15	15
IEEE 802.11g OFDM	0C	0C	0C
IEEE 802.11n (HT20)	09	09	09
IEEE 802.11n (HT40)	08	08	08

1.7 Test Facility

The tests were performed at:

Bontek Compliance Testing Laboratory Ltd

1/F., Block East H-3, OCT Eastern Ind. Zone, Qiaocheng East Road, Nanshan, Shenzhen, 518055 China

Tel: 86-755-86337020 Fax: 86-755-86337028

At the time of testing, the Laboratory is accredited. It is listed in the United States of American Federal Communications Commission (FCC), and the registration number is 338263.

The test report was fulfilled by Shenzhen Toby Technology Co., Ltd. Shenzhen Toby Technology Co., Ltd. is assumed full responsibility for the accuracy and completeness of these measurements results.

2. Test Summary

FCC Part 15 Subpart C(15.247)			
Standard Section	Test Item	Judgment	Remark
15.203	Antenna Requirement	PASS	N/A
15.207	Conducted Emission	PASS	N/A
15.205	Restricted Bands	PASS	N/A
15.247(a)(2)	6dB Bandwidth	PASS	N/A
15.247(b)	Peak Output Power	PASS	N/A
15.247(e)	Power Spectral Density	PASS	N/A
15.247(d)	Radiated Spurious Emission	PASS	N/A
15.247(d)	Antenna Conducted Spurious Emission	PASS	N/A

Note: N/A is an abbreviation for Not Applicable.

3. Conducted Emission Test

3.1 Test Standard and Limit

3.1.1 Test Standard

FCC Part 15.207

3.1.2 Test Limit

Conducted Emission Test Limit

Frequency	Maximum RF Line Voltage (dB μ V)	
	Quasi-peak Level	Average Level
150kHz~500kHz	66 ~ 56 *	56 ~ 46 *
500kHz~5MHz	56	46
5MHz~30MHz	60	50

Notes:

- (1) *Decreasing linearly with logarithm of the frequency.
- (2) The lower limit shall apply at the transition frequencies.
- (3) The limit decrease in line with the logarithm of the frequency in the range of 0.15 to 0.50MHz.

3.2 Test Setup

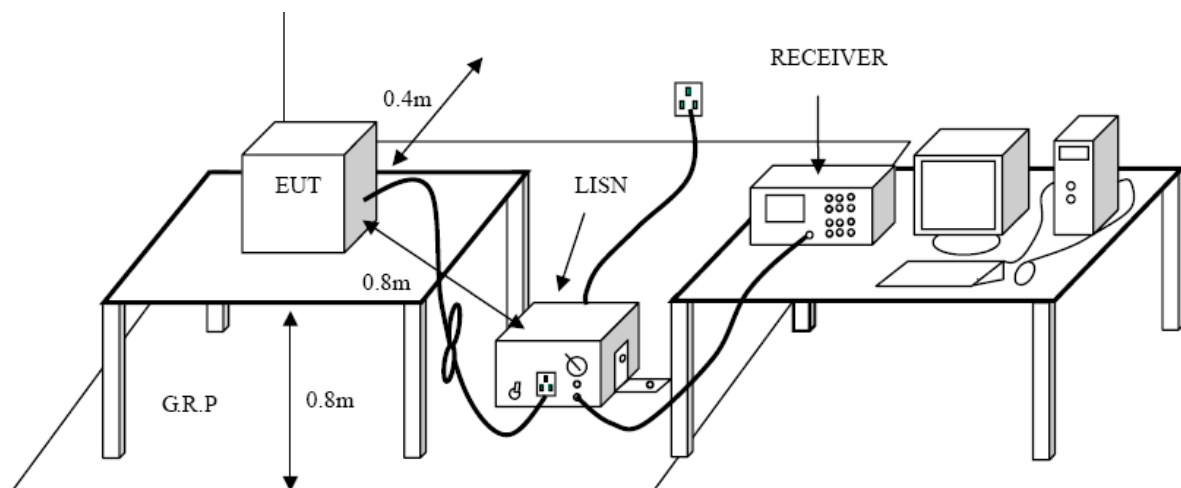

3.3 Test Procedure

The EUT was placed 0.8 meters from the horizontal ground plane with EUT being connected to the power mains through a line impedance stabilization network (LISN). All other support equipments powered from additional LISN(s). The LISN provide 50 Ohm/ 50uH of coupling impedance for the measuring instrument.

Interconnecting cables that hang closer than 40 cm to the ground plane shall be folded back and forth in the center forming a bundle 30 to 40 cm long.

I/O cables that are not connected to a peripheral shall be bundled in the center. The end of the cable may be terminated, if required, using the correct terminating impedance. The overall length shall not exceed 1 m.

LISN at least 80 cm from nearest part of EUT chassis.

The bandwidth of EMI test receiver is set at 9kHz, and the test frequency band is from 0.15MHz to 30MHz.

3.4 Test Equipment Used

Description	Manufacturer	Model No.	Serial No.	Cal. Date	Cal. Date
EMI Test Receiver	ROHDE& SCHWARZ	ESC30	DE25181	2012-08-07	2013-08-06
50ΩCoaxial Switch	Anritsu	MP59B	X10321	2012-08-07	2013-08-06
L.I.S.N	EMCO	3624/1	00063417	2012-08-07	2013-08-06
L.I.S.N	EMCO	3624/1	00063417	2012-08-07	2013-08-06

3.5 EUT Operating Mode

Please refer to the description of test mode.

3.6 Test Data

Please see the next page.

E.U.T :	WIFI MODULE	Model Name :	WF71RL1500C
Temperature :	23°C	Relative Humidity :	51 %
Terminal	Line		
Test Voltage :	AC 120 V / 60Hz		
Test Mode :	TX Mode (B Mode)		

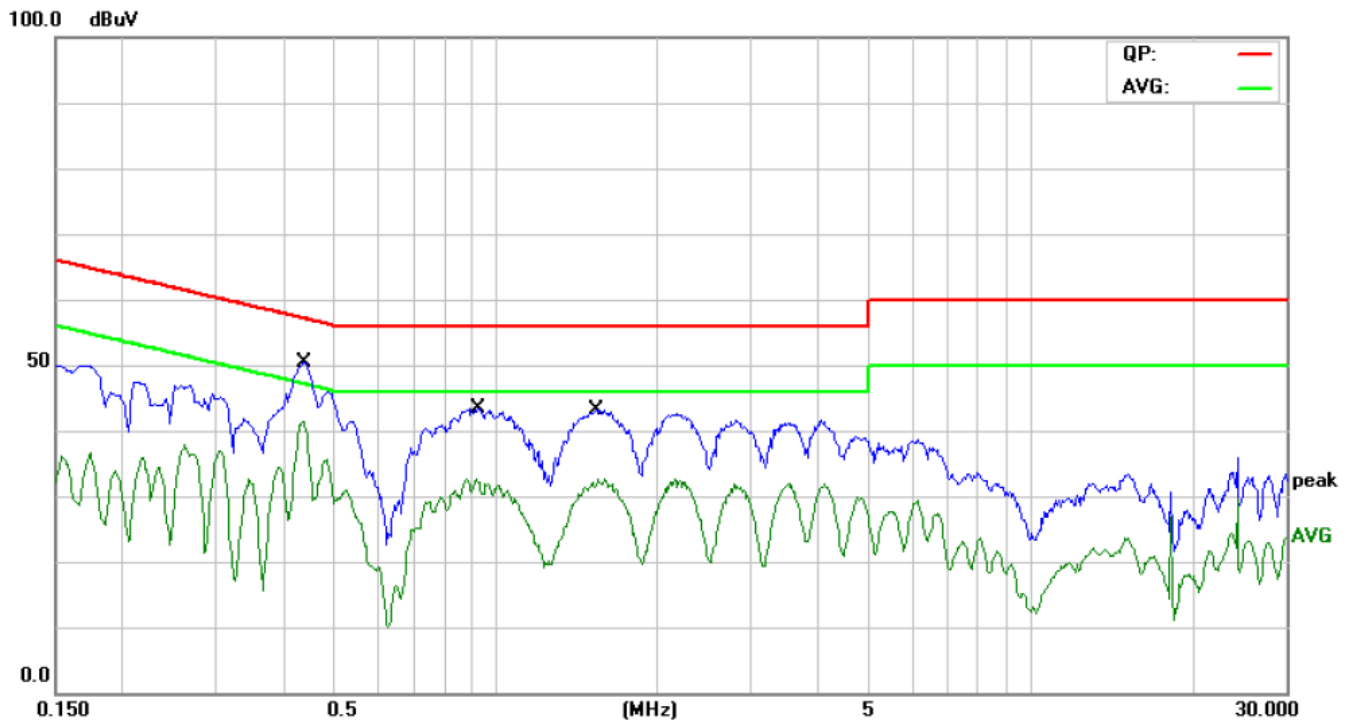

No.	Mk.	Freq. MHz	Reading Level dBuV	Correct Factor dB	Measure- ment dBuV	Limit dBuV	Over dB	Detector	Comment
1	*	0.4380	39.27	9.56	48.83	57.10	-8.27	QP	
2		0.4380	27.55	9.56	37.11	47.10	-9.99	AVG	
3		0.9260	29.35	9.36	38.71	56.00	-17.29	QP	
4		0.9260	19.42	9.36	28.78	46.00	-17.22	AVG	
5		1.5420	27.78	9.32	37.10	56.00	-18.90	QP	
6		1.5420	19.52	9.32	28.84	46.00	-17.16	AVG	

E.U.T :	WIFI MODULE	Model Name :	WF71RL1500C
Temperature :	23°C	Relative Humidity :	51 %
Terminal	Neutral		
Test Voltage :	AC 120 V / 60Hz		
Test Mode :	TX Mode (B Mode)		

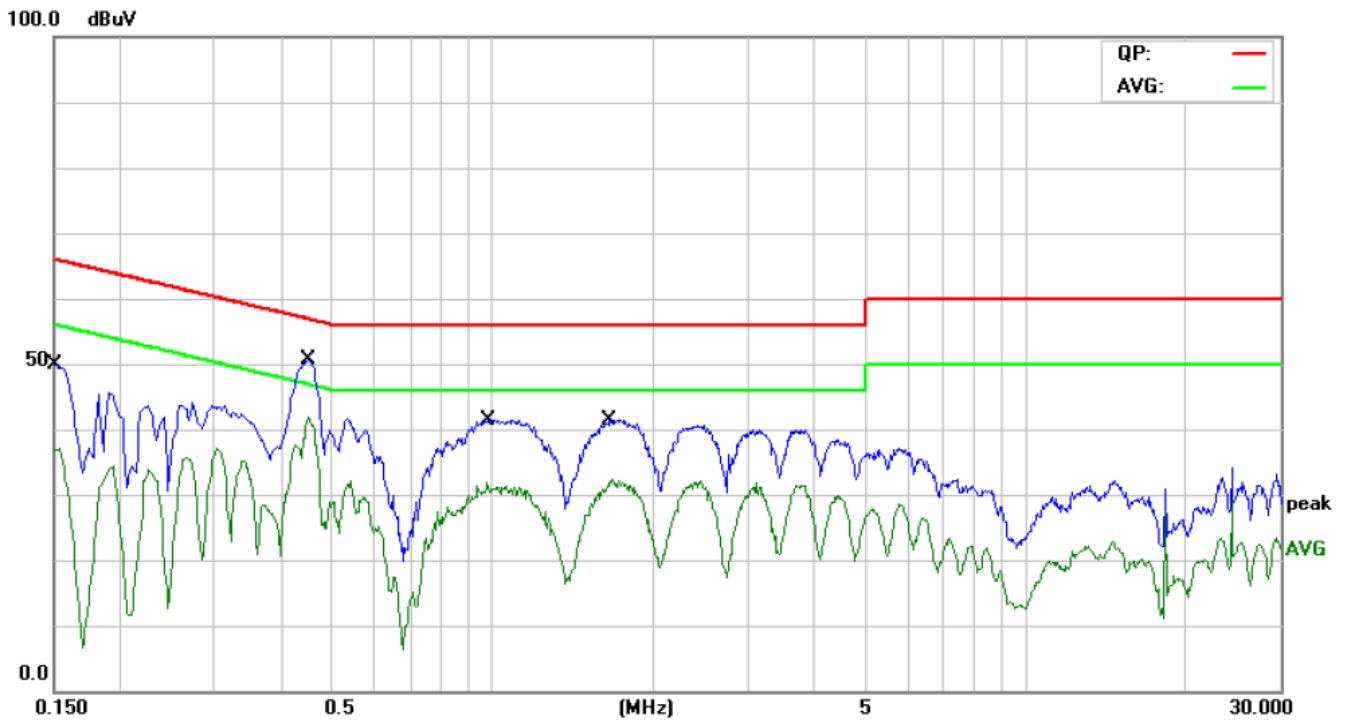

No.	Mk.	Freq. MHz	Reading Level dBuV	Correct Factor dB	Measure- ment dBuV	Limit dBuV	Over dB	Detector	Comment
1		0.1500	36.29	10.93	47.22	65.99	-18.77	QP	
2		0.1500	25.14	10.93	36.07	55.99	-19.92	AVG	
3		0.4500	40.07	9.57	49.64	56.87	-7.23	QP	
4	*	0.4500	32.50	9.57	42.07	46.87	-4.80	AVG	
5		0.9820	30.10	9.34	39.44	56.00	-16.56	QP	
6		0.9820	21.16	9.34	30.50	46.00	-15.50	AVG	
7		1.6540	28.98	9.35	38.33	56.00	-17.67	QP	
8		1.6540	21.08	9.35	30.43	46.00	-15.57	AVG	

4. Radiated Emission Test

4.1 Test Standard and Limit

4.1.1 Test Standard

FCC Part 15.209

4.1.2 Test Limit

Radiated Emission Limits (9kHz~1000MHz)

Frequency (MHz)	Field Strength (microvolt/meter)	Measurement Distance (meters)
0.009~0.490	2400/F(KHz)	300
0.490~1.705	24000/F(KHz)	30
1.705~30.0	30	30
30~88	100	3
88~216	150	3
216~960	200	3
Above 960	500	3

Radiated Emission Limit (Above 1000MHz)

Frequency (MHz)	Class A (dBuV/m)(at 3 M)		Class B (dBuV/m)(at 3 M)	
	Peak	Average	Peak	Average
Above 1000	80	60	74	54

Note:

- (1) The tighter limit applies at the band edges.
- (2) Emission Level(dBuV/m)=20log Emission Level(uV/m)

4.2 Test Setup

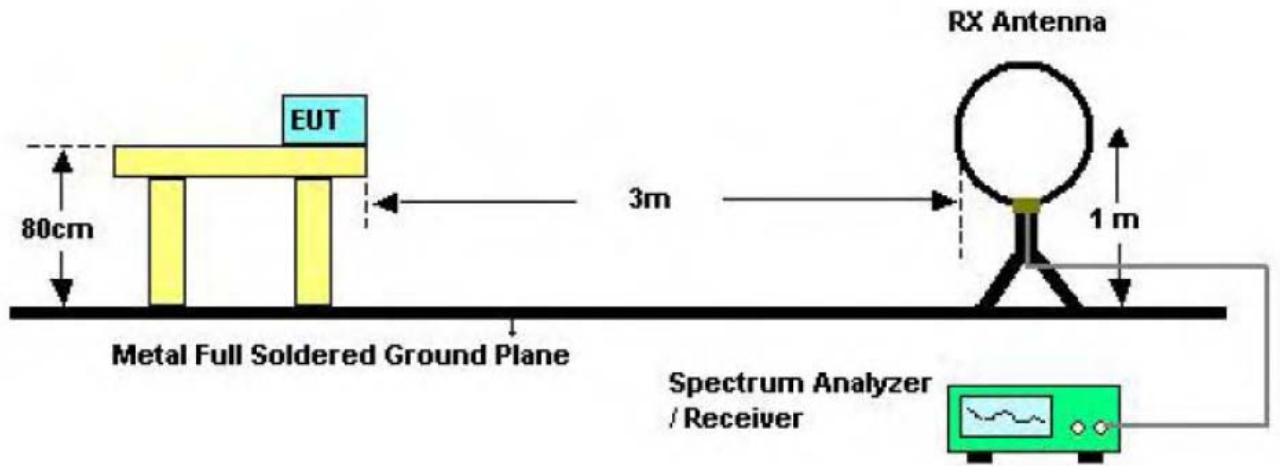

Bellow 30MHz Test Setup

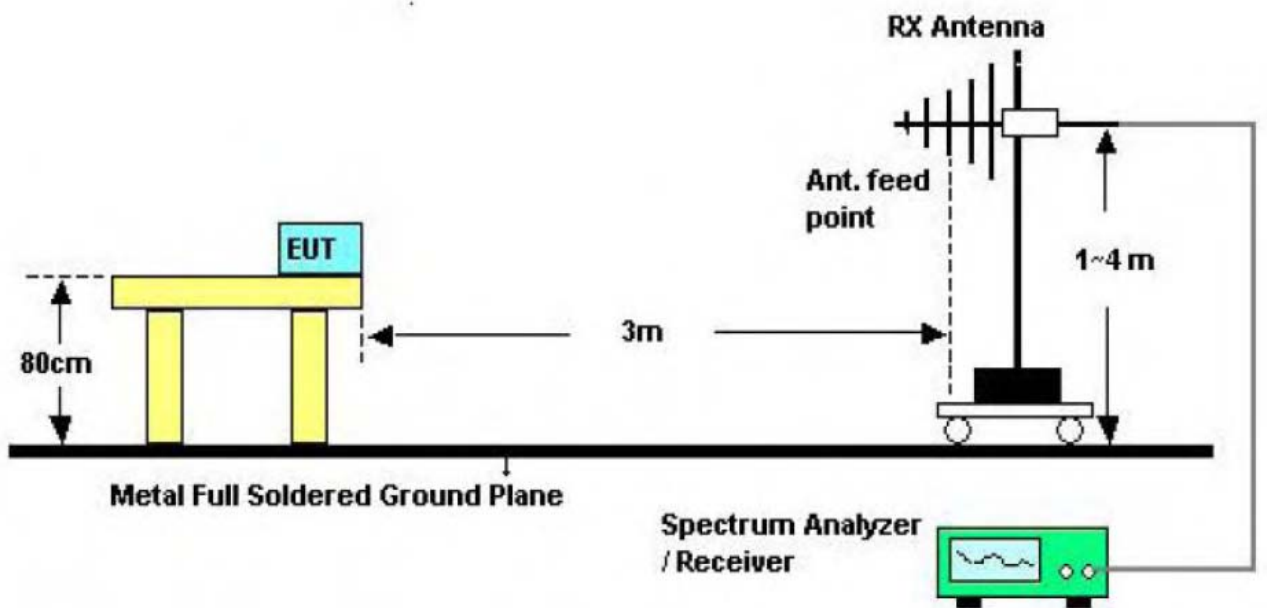

Bellow 1000MHz Test Setup

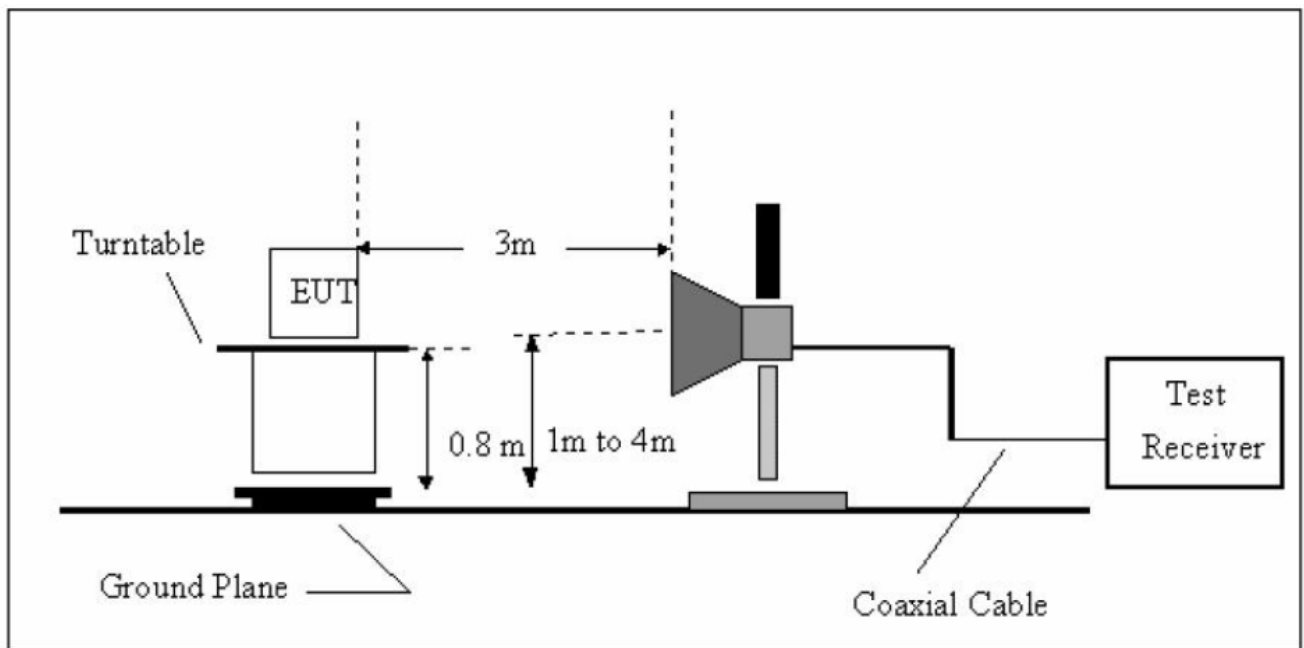

Above 1GHz Test Setup

4.3 Test Procedure

- (1) The measuring distance of 3m shall be used for measurements at frequency up to 1GHz and above 1 GHz. The EUT was placed on a rotating 0.8m high above ground, the table was rotated 360 degrees to determine the position of the highest radiation.
- (2) The Test antenna shall vary between 1m and 4m, Both Horizontal and Vertical antenna are set to make measurement.
- (3) The initial step in collecting conducted emission data is a spectrum analyzer peak detector mode pre-scanning the measurement frequency range. Significant peaks are then marked and then Quasi Peak detector mode re-measured.
- (4) If the Peak Mode measured value compliance with and lower than Quasi Peak Mode Limit Bellow 1 GHz, the EUT shall be deemed to meet QP Limits and then no additional QP Mode measurement performed. But the Peak Value and average value both need to comply with applicable limit above 1 GHz.
- (5) For the actual test configuration, please see the test setup photo.

4.4 EUT Operating Condition

The Equipment Under Test was set to Continual Transmitting in maximum power.

4.5 Test Equipment

Description	Manufacturer	Model No.	Serial No.	Cal. Date	Cal. Date
Spectrum Analyzer	ROHDE& SCHWARZ	FSEA20	DE25181	2012-08-07	2013-08-06
Positioning Controller	C&C	CC-C-1F	N/A	2012-08-07	2013-08-06
Trilog Broadband Antenna	SCHWARZBEC K	VULB9163	9163-333	2012-07-13	2013-07-12
Horn Antenna	SCHWARZBEC K	BBHX 9120	9120-426	2012-07-13	2013-07-12
RF Switch	EM	EMSW18	SW060023	2012-08-07	2013-08-06
Amplifier	Agilent	8447F	3113A06717	2012-08-07	2013-08-06
Coaxial Cable	SCHWARZBEC K	AK9513	9513-10	2012-08-07	2013-08-06
EMI Test Receiver	ROHDE& SCHWARZ	ESPI	25498514	2012-08-07	2013-08-06
EMI Test Receiver	ROHDE& SCHWARZ	ESI26	838786/103	2012-08-07	2013-08-06
Receiver Horn Antenna	ROHDE& SCHWARZ	HF906	100013	2012-08-07	2013-08-06

4.6 Test Data

Please see the next page.

Operation Mode: 802.11b Test Date : August 15, 2012
 TX 2412MHz
Frequency Range: 30~1000MHz Temperature : 28 °C
Measured Distance: 3m Humidity : 65 %
Test Voltage: AC 120V/60Hz

Freq. (MHz)	Ant.Pol. H/V	Emission Level (dBuV)	Limit (3m) (dBuV/m)	Margin (dB)	Note
80.920	H	31.91	40.00	8.09	PK
250.670	H	32.84	46.00	13.16	PK
352.520	H	37.42	46.00	8.58	PK
401.120	H	37.28	46.00	8.72	PK
534.400	H	36.14	46.00	9.86	PK
674.120	H	38.09	46.00	7.91	PK
112.450	V	34.53	43.50	7.97	PK
250.670	V	35.50	46.00	10.50	PK
267.650	V	36.17	46.00	9.83	PK
534.400	V	36.33	46.00	9.67	PK
607.770	V	35.03	46.00	10.97	PK
674.120	V	38.30	46.00	7.70	PK

- Note:**
- (1) All Readings are Peak Value.
 - (2) Emission Level= Reading Level+ Probe Factor +Cable Loss
 - (3) The average measurement was not performed when the peak measured data under the limit of average detection.

Operation Mode: 802.11b TX 2412MHz Test Date : August 15, 2012
 Frequency Range: 1-25GHz Temperature : 28 °C
 Measured Distance: 3m Humidity : 65 %
 Test Voltage: AC 120V/60Hz

Freq. (MHz)	Ant.Pol. H/V	Emission Level (dBuV/m)		Limit3m (dBuV/m)		Margin(dB)	
		PK	AV	PK	AV	PK	AV
4823.880	V	57.45	46.70	74.00	54.00	16.55	7.30
7235.980	V	48.68	40.02	74.00	54.00	25.32	13.98
--	V	--	--	74.00	54.00	--	--
--	V	--	--	74.00	54.00	--	--
--	V	--	--	74.00	54.00	--	--
4823.880	H	58.12	47.61	74.00	54.00	15.88	6.39
7235.850	H	49.60	40.35	74.00	54.00	24.4	13.65
--	H	--	--	74.00	54.00	--	--
--	H	--	--	74.00	54.00	--	--
--	H	--	--	74.00	54.00	--	--

Other harmonics emissions are lower than 20dB below the allowable limit.

- Note:**
- (1) All Readings are Peak Value and AV.
 - (2) Emission Level= Reading Level + Probe Factor +Cable Loss
 - (3) Data of measurement within this frequency range shown “ -- ” in the table above means the reading of emissions are attenuated more than 20dB below the permissible limits or the field strength is too small to be measured.

Operation Mode:	802.11b TX 2437MHz	Test Date :	August 15, 2012
Frequency Range:	1-25GHz	Temperature :	28 °C
Measured Distance:	3m	Humidity :	65 %
Test Voltage:	AC 120V/60Hz		

Freq. (MHz)	Ant.Pol. H/V	Emission Level (dBuV/m)		Limit3m (dBuV/m)		Margin(dB)	
		PK	AV	PK	AV	PK	AV
4874.010	V	57.66	46.68	74.00	54.00	16.34	7.32
7311.110	V	48.40	37.79	74.00	54.00	25.60	16.21
--	V	--	--	74.00	54.00	--	--
--	V	--	--	74.00	54.00	--	--
--	V	--	--	74.00	54.00	--	--
4874.010	H	57.96	47.45	74.00	54.00	16.04	6.55
7311.100	H	48.61	38.87	74.00	54.00	25.39	15.13
--	H	--	--	74.00	54.00	--	--
--	H	--	--	74.00	54.00	--	--
--	H	--	--	74.00	54.00	--	--

Other harmonics emissions are lower than 20dB below the allowable limit.

- Note:**
- (1) All Readings are Peak Value and AV.
 - (2) Emission Level= Reading Level + Probe Factor +Cable Loss
 - (3) Data of measurement within this frequency range shown “ -- ” in the table above means the reading of emissions are attenuated more than 20dB below the permissible limits or the field strength is too small to be measured.

Operation Mode:	802.11b TX 2462MHz	Test Date :	August 15, 2012
Frequency Range:	1-25GHz	Temperature :	28 °C
Measured Distance:	3m	Humidity :	65 %
Test Voltage:	AC 120V/60Hz		

Freq. (MHz)	Ant.Pol. H/V	Emission Level (dBuV/m)		Limit3m (dBuV/m)		Margin(dB)	
		PK	AV	PK	AV	PK	AV
4924.210	V	56.59	47.74	74.00	54.00	17.41	6.26
7386.320	V	47.64	37.47	74.00	54.00	26.36	16.53
--	V	--	--	74.00	54.00	--	--
--	V	--	--	74.00	54.00	--	--
--	V	--	--	74.00	54.00	--	--
4924.210	H	57.87	47.93	74.00	54.00	16.13	6.07
7386.360	H	48.06	38.52	74.00	54.00	25.94	15.48
--	H	--	--	74.00	54.00	--	--
--	H	--	--	74.00	54.00	--	--
--	H	--	--	74.00	54.00	--	--

Other harmonics emissions are lower than 20dB below the allowable limit.

Note:

- (1) All Readings are Peak Value and AV.
- (2) Emission Level= Reading Level + Probe Factor +Cable Loss
- (3) Data of measurement within this frequency range shown “ -- ” in the table above means the reading of emissions are attenuated more than 20dB below the permissible limits or the field strength is too small to be measured.

Operation Mode:	802.11g TX 2412MHz	Test Date :	August 15, 2012
Frequency Range:	1-25GHz	Temperature :	28 °C
Measured Distance:	3m	Humidity :	65 %
Test Voltage:	AC 120V/60Hz		

Freq. (MHz)	Ant.Pol. H/V	Emission Level (dBuV/m)		Limit3m (dBuV/m)		Margin(dB)	
		PK	AV	PK	AV	PK	AV
4823.960	V	47.88	47.10	74.00	54.00	16.12	6.90
7235.920	V	46.82	37.24	74.00	54.00	27.18	16.76
--	V	--	--	74.00	54.00	--	--
--	V	--	--	74.00	54.00	--	--
--	V	--	--	74.00	54.00	--	--
4823.960	H	57.90	47.78	74.00	54.00	16.10	6.22
7235.920	H	46.74	37.92	74.00	54.00	27.26	16.08
--	H	--	--	74.00	54.00	--	--
--	H	--	--	74.00	54.00	--	--
--	H	--	--	74.00	54.00	--	--

Other harmonics emissions are lower than 20dB below the allowable limit.

- Note:**
- (1) All Readings are Peak Value and AV.
 - (2) Emission Level= Reading Level + Probe Factor +Cable Loss
 - (3) Data of measurement within this frequency range shown “ -- ” in the table above means the reading of emissions are attenuated more than 20dB below the permissible limits or the field strength is too small to be measured.

Operation Mode:	802.11g TX 2437MHz	Test Date :	August 15, 2012
Frequency Range:	1-25GHz	Temperature :	28 °C
Measured Distance:	3m	Humidity :	65 %
Test Voltage:	AC 120V/60Hz		

Freq. (MHz)	Ant.Pol. H/V	Emission Level (dBuV/m)		Limit3m (dBuV/m)		Margin(dB)	
		PK	AV	PK	AV	PK	AV
4874.120	V	57.63	46.46	74.00	54.00	16.37	7.54
7311.360	V	46.14	35.08	74.00	54.00	27.86	18.92
--	V	--	--	74.00	54.00	--	--
--	V	--	--	74.00	54.00	--	--
--	V	--	--	74.00	54.00	--	--
4874.120	H	57.93	47.56	74.00	54.00	16.07	6.44
7311.360	H	46.40	35.11	74.00	54.00	27.60	18.89
--	H	--	--	74.00	54.00	--	--
--	H	--	--	74.00	54.00	--	--
--	H	--	--	74.00	54.00	--	--

Other harmonics emissions are lower than 20dB below the allowable limit.

- Note:**
- (1) All Readings are Peak Value and AV.
 - (2) Emission Level= Reading Level + Probe Factor +Cable Loss
 - (3) Data of measurement within this frequency range shown “ -- ” in the table above means the reading of emissions are attenuated more than 20dB below the permissible limits or the field strength is too small to be measured.

Operation Mode:	802.11g TX 2462MHz	Test Date :	August 15, 2012
Frequency Range:	1-25GHz	Temperature :	28 °C
Measured Distance:	3m	Humidity :	65 %
Test Voltage:	AC 120V/60Hz		

Freq. (MHz)	Ant.Pol. H/V	Emission Level (dBuV/m)		Limit3m (dBuV/m)		Margin(dB)	
		PK	AV	PK	AV	PK	AV
4924.030	V	56.47	47.97	74.00	54.00	17.53	6.03
7386.410	V	47.41	36.85	74.00	54.00	26.59	17.15
--	V	--	--	74.00	54.00	--	--
--	V	--	--	74.00	54.00	--	--
--	V	--	--	74.00	54.00	--	--
4924.200	H	57.87	48.14	74.00	54.00	16.13	5.86
7386.420	H	47.81	37.15	74.00	54.00	26.19	16.85
--	H	--	--	74.00	54.00	--	--
--	H	--	--	74.00	54.00	--	--
--	H	--	--	74.00	54.00	--	--

Other harmonics emissions are lower than 20dB below the allowable limit.

Note:

- (1) All Readings are Peak Value and AV.
- (2) Emission Level= Reading Level + Probe Factor +Cable Loss
- (3) Data of measurement within this frequency range shown “ -- ” in the table above means the reading of emissions are attenuated more than 20dB below the permissible limits or the field strength is too small to be measured.

Operation Mode: 802.11n (HT20) TX 2412MHz Test Date : August 15, 2012
 Frequency Range: 1-25GHz Temperature : 28 °C
 Measured Distance: 3m Humidity : 65 %
 Test Voltage: AC 120V/60Hz

Freq. (MHz)	Ant.Pol. H/V	Emission Level (dBUV/m)		Limit3m (dBUV/m)		Margin(dB)	
		PK	AV	PK	AV	PK	AV
4824.020	V	55.50	45.60	74.00	54.00	18.50	8.40
7236.300	V	45.26	35.27	74.00	54.00	28.74	18.73
--	V	--	--	74.00	54.00	--	--
--	V	--	--	74.00	54.00	--	--
--	V	--	--	74.00	54.00	--	--
4824.020	H	56.50	45.83	74.00	54.00	17.50	8.17
7236.320	H	46.23	35.78	74.00	54.00	27.77	18.22
--	H	--	--	74.00	54.00	--	--
--	H	--	--	74.00	54.00	--	--
--	H	--	--	74.00	54.00	--	--

Other harmonics emissions are lower than 20dB below the allowable limit.

- Note:**
- (1) All Readings are Peak Value and AV.
 - (2) Emission Level= Reading Level + Probe Factor +Cable Loss
 - (3) Data of measurement within this frequency range shown “ -- ” in the table above means the reading of emissions are attenuated more than 20dB below the permissible limits or the field strength is too small to be measured.

Operation Mode: 802.11n (HT20) TX 2437MHz Test Date : August 15, 2012
 Frequency Range: 1-25GHz Temperature : 28 °C
 Measured Distance: 3m Humidity : 65 %
 Test Voltage: AC 120V/60Hz

Freq. (MHz)	Ant.Pol. H/V	Emission Level (dBuV/m)		Limit3m (dBuV/m)		Margin(dB)	
		PK	AV	PK	AV	PK	AV
4874.030	V	55.44	45.29	74.00	54.00	18.56	8.71
7312.410	V	45.05	39.88	74.00	54.00	28.95	14.12
--	V	--	--	74.00	54.00	--	--
--	V	--	--	74.00	54.00	--	--
--	V	--	--	74.00	54.00	--	--
4874.030	H	56.29	45.78	74.00	54.00	17.17	8.22
7312.620	H	45.37	35.20	74.00	54.00	28.63	18.80
--	H	--	--	74.00	54.00	--	--
--	H	--	--	74.00	54.00	--	--
--	H	--	--	74.00	54.00	--	--

Other harmonics emissions are lower than 20dB below the allowable limit.

- Note:**
- (1) All Readings are Peak Value and AV.
 - (2) Emission Level= Reading Level + Probe Factor +Cable Loss
 - (3) Data of measurement within this frequency range shown “ -- ” in the table above means the reading of emissions are attenuated more than 20dB below the permissible limits or the field strength is too small to be measured.

Operation Mode: 802.11n (HT20) TX 2462MHz Test Date : August 15, 2012
 Frequency Range: 1-25GHz Temperature : 28 °C
 Measured Distance: 3m Humidity : 65 %
 Test Voltage: AC 120V/60Hz

Freq. (MHz)	Ant.Pol. H/V	Emission Level (dBuV/m)		Limit3m (dBuV/m)		Margin(dB)	
		PK	AV	PK	AV	PK	AV
4924.110	V	55.63	45.59	74.00	54.00	18.37	8.41
7386.320	V	46.11	35.80	74.00	54.00	27.89	18.20
--	V	--	--	74.00	54.00	--	--
--	V	--	--	74.00	54.00	--	--
--	V	--	--	74.00	54.00	--	--
4924.110	H	56.62	46.96	74.00	54.00	17.38	7.04
7386.320	H	46.28	35.92	74.00	54.00	27.72	18.08
--	H	--	--	74.00	54.00	--	--
--	H	--	--	74.00	54.00	--	--
--	H	--	--	74.00	54.00	--	--

Other harmonics emissions are lower than 20dB below the allowable limit.

- Note:**
- (1) All Readings are Peak Value and AV.
 - (2) Emission Level= Reading Level + Probe Factor +Cable Loss
 - (3) Data of measurement within this frequency range shown “ -- ” in the table above means the reading of emissions are attenuated more than 20dB below the permissible limits or the field strength is too small to be measured.

Operation Mode: 802.11n (HT40) TX 2422MHz Test Date : August 15, 2012
 Frequency Range: 1-25GHz Temperature : 28 °C
 Measured Distance: 3m Humidity : 65 %
 Test Voltage: AC 120V/60Hz

Freq. (MHz)	Ant.Pol. H/V	Emission Level (dBuV/m)		Limit3m (dBuV/m)		Margin(dB)	
		PK	AV	PK	AV	PK	AV
4844.100	V	55.00	44.97	74.00	54.00	19.00	9.03
7238.220	V	43.27	33.15	74.00	54.00	30.73	20.85
--	V	--	--	74.00	54.00	--	--
--	V	--	--	74.00	54.00	--	--
--	V	--	--	74.00	54.00	--	--
4844.100	H	55.34	45.44	74.00	54.00	18.66	8.56
7238.220	H	43.63	33.50	74.00	54.00	30.37	20.50
--	H	--	--	74.00	54.00	--	--
--	H	--	--	74.00	54.00	--	--
--	H	--	--	74.00	54.00	--	--

Other harmonics emissions are lower than 20dB below the allowable limit.

- Note:**
- (1) All Readings are Peak Value and AV.
 - (2) Emission Level= Reading Level + Probe Factor +Cable Loss
 - (3) Data of measurement within this frequency range shown “ -- ” in the table above means the reading of emissions are attenuated more than 20dB below the permissible limits or the field strength is too small to be measured.

Operation Mode: 802.11n (HT40) TX 2437MHz Test Date : August 15, 2012
 Frequency Range: 1-25GHz Temperature : 28 °C
 Measured Distance: 3m Humidity : 65 %
 Test Voltage: AC 120V/60Hz

Freq. (MHz)	Ant.Pol. H/V	Emission Level (dBuV/m)		Limit3m (dBuV/m)		Margin(dB)	
		PK	AV	PK	AV	PK	AV
4874.100	V	55.45	45.55	74.00	54.00	18.55	8.45
7312.200	V	43.81	33.74	74.00	54.00	30.19	20.26
--	V	--	--	74.00	54.00	--	--
--	V	--	--	74.00	54.00	--	--
--	V	--	--	74.00	54.00	--	--
4875.240	H	54.45	45.04	74.00	54.00	19.55	8.96
7312.210	H	43.47	33.20	74.00	54.00	30.53	20.80
--	H	--	--	74.00	54.00	--	--
--	H	--	--	74.00	54.00	--	--
--	H	--	--	74.00	54.00	--	--

Other harmonics emissions are lower than 20dB below the allowable limit.

- Note:**
- (1) All Readings are Peak Value and AV.
 - (2) Emission Level= Reading Level + Probe Factor +Cable Loss
 - (3) Data of measurement within this frequency range shown “ -- ” in the table above means the reading of emissions are attenuated more than 20dB below the permissible limits or the field strength is too small to be measured.

Operation Mode: 802.11n (HT40) TX 2452MHz Test Date : August 15, 2012
 Frequency Range: 1-25GHz Temperature : 28 °C
 Measured Distance: 3m Humidity : 65 %
 Test Voltage: AC 120V/60Hz

Freq. (MHz)	Ant.Pol. H/V	Emission Level (dBuV/m)		Limit3m (dBuV/m)		Margin(dB)	
		PK	AV	PK	AV	PK	AV
4906.020	V	55.15	44.66	74.00	54.00	18.85	9.34
7358.040	V	43.72	33.80	74.00	54.00	30.28	20.20
--	V	--	--	74.00	54.00	--	--
--	V	--	--	74.00	54.00	--	--
--	V	--	--	74.00	54.00	--	--
4906.020	H	56.22	45.67	74.00	54.00	17.78	8.33
7358.040	H	43.91	34.23	74.00	54.00	30.09	19.77
--	H	--	--	74.00	54.00	--	--
--	H	--	--	74.00	54.00	--	--
--	H	--	--	74.00	54.00	--	--

Other harmonics emissions are lower than 20dB below the allowable limit.

- Note:**
- (1) All Readings are Peak Value and AV.
 - (2) Emission Level= Reading Level + Probe Factor +Cable Loss
 - (3) Data of measurement within this frequency range shown “ -- ” in the table above means the reading of emissions are attenuated more than 20dB below the permissible limits or the field strength is too small to be measured.

5. Restricted Bands Requirement

5.1 Test Standard and Limit

5.1.1 Test Standard

FCC Part 15.209

FCC Part 15.205

5.1.2 Test Limit

Restricted Frequency Band (MHz)	Class B (dBuV/m)(at 3 M)	
	Peak	Average
2310 ~2390	74	54
2483.5 ~2500	74	54

5.2 Test Setup

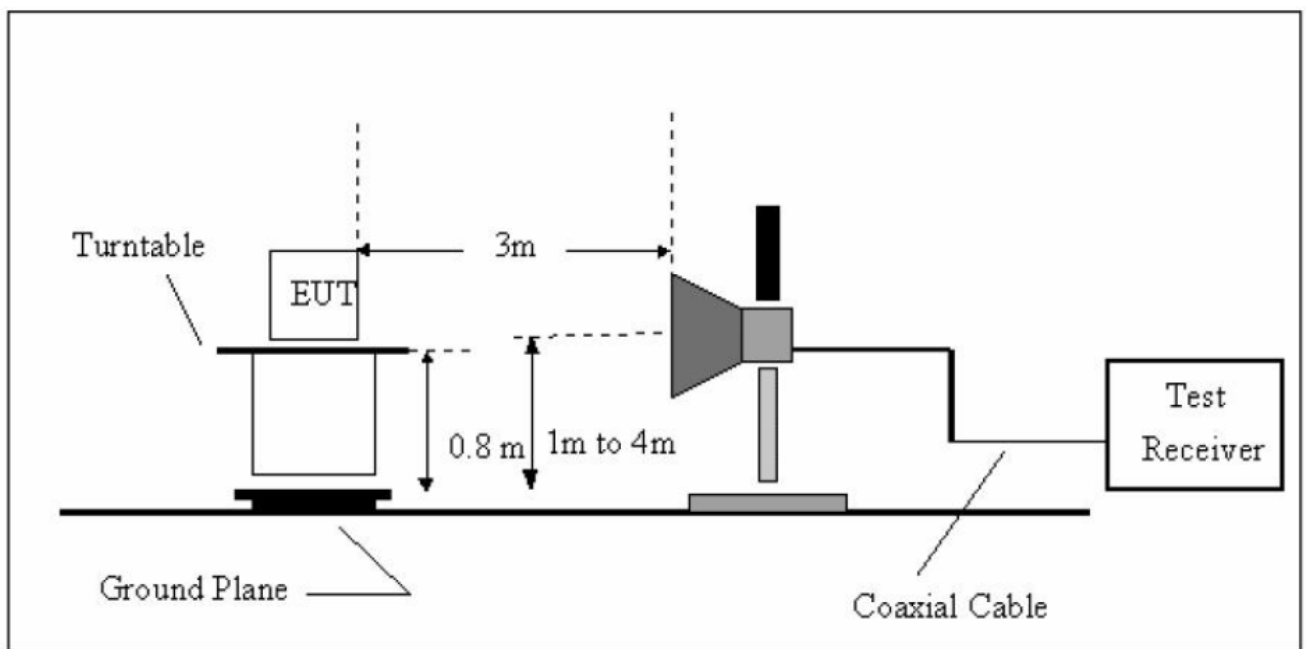

5.3 Test Procedure

- (1) The measuring distance of 3m shall be used for measurements at frequency up to 1GHz and above 1 GHz. The EUT was placed on a rotating 0.8m high above ground, the table was rotated 360 degrees to determine the position of the highest radiation.
- (2) The Test antenna shall vary between 1m and 4m, Both Horizontal and Vertical antenna are set to make measurement.
- (3) The initial step in collecting conducted emission data is a spectrum analyzer peak detector mode pre-scanning the measurement frequency range. Significant peaks are then marked and then Quasi Peak detector mode re-measured.

(4) If the Peak Mode measured value compliance with and lower than Quasi Peak Mode Limit Bellow 1 GHz, the EUT shall be deemed to meet QP Limits and then no additional QP Mode measurement performed. But the Peak Value and average value both need to comply with applicable limit above 1 GHz.

(5) For the actual test configuration, please see the test setup photo.

5.4 EUT Operating Condition

The Equipment Under Test was set to Continual Transmitting in maximum power.

5.5 Test Equipment

Description	Manufacturer	Model No.	Serial No.	Cal. Date	Cal. Date
Spectrum Analyzer	ROHDE& SCHWARZ	FSEA20	DE25181	2012-08-07	2013-08-06
Positioning Controller	C&C	CC-C-1F	N/A	2012-08-07	2013-08-06
Trilog Broadband Antenna	SCHWARZBEC K	VULB9163	9163-333	2012-07-13	2013-07-12
Horn Antenna	SCHWARZBEC K	BBHX 9120	9120-426	2012-07-13	2013-07-12
RF Switch	EM	EMSW18	SW060023	2012-08-07	2013-08-06
Amplifier	Agilent	8447F	3113A06717	2012-08-07	2013-08-06
Coaxial Cable	SCHWARZBEC K	AK9513	9513-10	2012-08-07	2013-08-06
EMI Test Receiver	ROHDE& SCHWARZ	ESPI	25498514	2012-08-07	2013-08-06
EMI Test Receiver	ROHDE& SCHWARZ	ESI26	838786/103	2012-08-07	2013-08-06
Receiver Horn Antenna	ROHDE& SCHWARZ	HF906	100013	2012-08-07	2013-08-06

5.6 Test Data

Please see the next page.

Spectrum Detector: PK
 Temperature : 28 °C

Test Date : August 14, 2012
 Humidity : 65 %

802.11b Mode

1. Conducted Test

Frequency (MHz)	Peak Power Output(dBm)	Emission Read Value(dBm)	Result of Band edge(dBc)	Band edge Limit(dBc)
<2400	3.12	-47.79	50.91	>20dBc
>2483.5	2.22	-48.05	50.27	>20dBc

2. Radiated emission test

Frequency (MHz)	Antenna polarization (H/V)	Emission (dBuV/m)		Band edge Limit (dBuV/m)	
		PEAK	AV	PEAK	AV
<2400	H	57.70	47.43	74.00	54.00
<2400	V	54.97	43.90	74.00	54.00
>2483.5	H	53.08	42.70	74.00	54.00
>2483.5	V	54.01	42.92	74.00	54.00

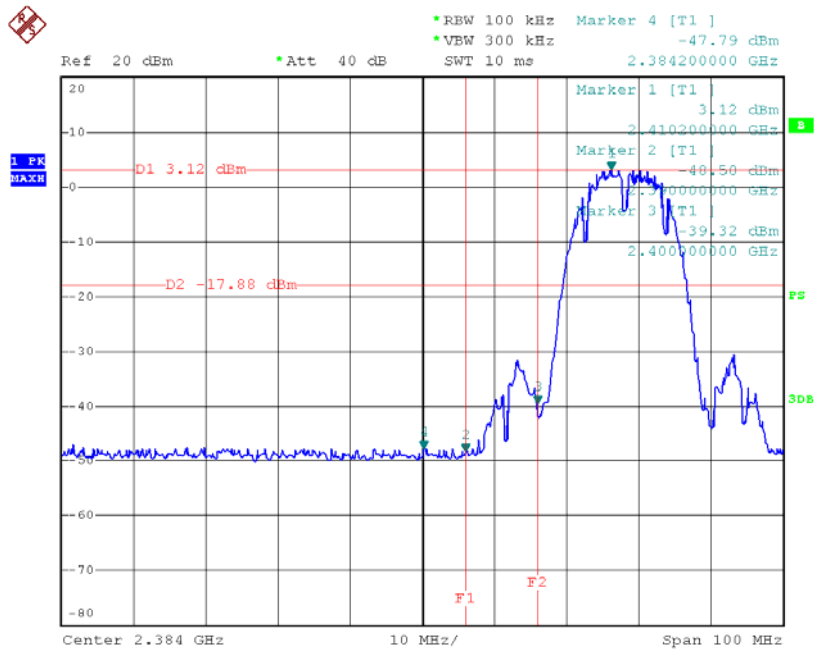

Date: 14.AUG.2012 15:41:24

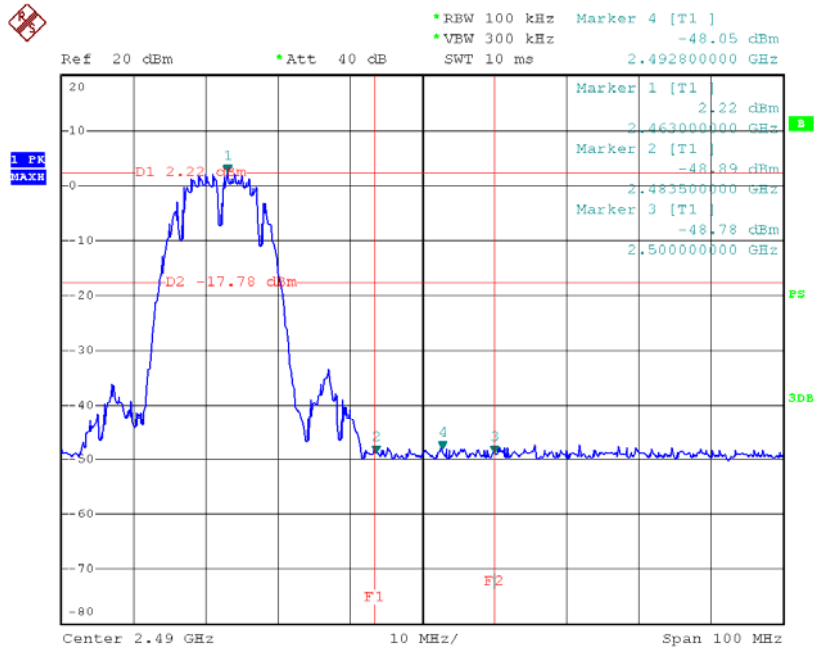

Date: 14.AUG.2012 15:59:34

Spectrum Detector: PK
 Temperature : 28 °C

Test Date : August 14, 2012
 Humidity : 65 %

802.11g Mode

1. Conducted Test

Frequency (MHz)	Peak Power Output(dBm)	Emission Read Value(dBm)	Result of Band edge(dBc)	Band edge Limit(dBc)
<2400	-6.09	-46.93	40.84	>20dBc
>2483.5	-6.98	-47.27	40.29	>20dBc

2. Radiated emission test

Frequency (MHz)	Antenna polarization (H/V)	Emission (dBuV/m)		Band edge Limit (dBuV/m)	
		PEAK	AV	PEAK	AV
<2400	H	55.68	44.59	74.00	54.00
<2400	V	54.96	43.59	74.00	54.00
>2483.5	H	53.47	43.13	74.00	54.00
>2483.5	V	54.15	43.28	74.00	54.00

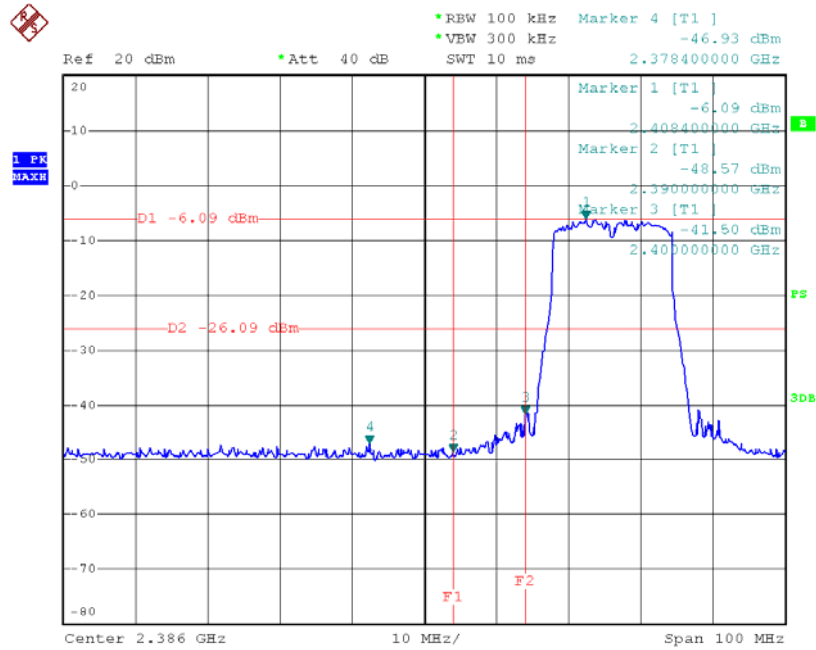

Date: 14.AUG.2012 16:07:01

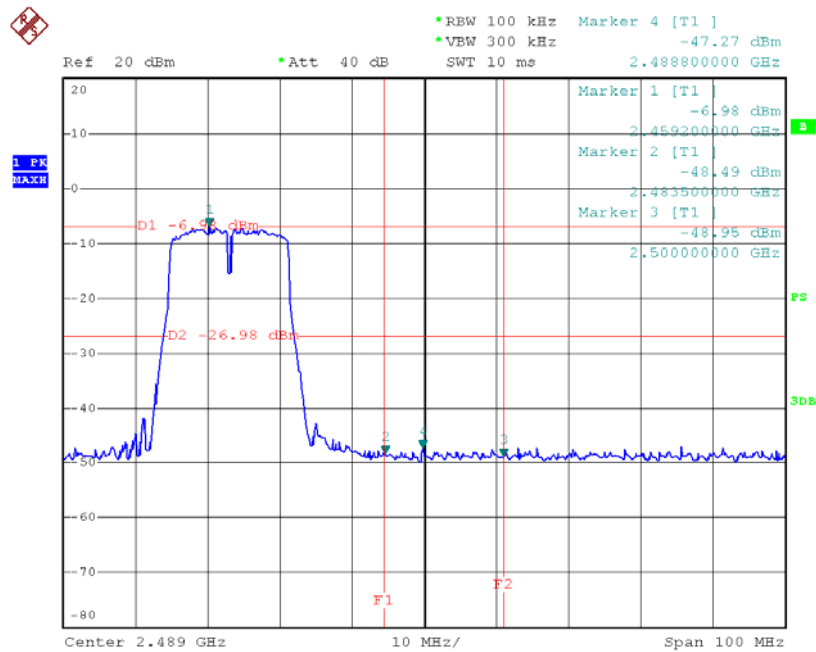

Date: 14.AUG.2012 16:35:40

Spectrum Detector: PK
 Temperature : 28 °C

Test Date : August 14, 2012
 Humidity : 65 %

802.11n (HT20) Mode

1. Conducted Test

Frequency (MHz)	Peak Power Output(dBm)	Emission Read Value(dBm)	Result of Band edge(dBc)	Band edge Limit(dBc)
<2400	-7.69	-47.45	39.76	>20dBc
>2483.5	-8.12	-47.81	39.69	>20dBc

2. Radiated emission test

Frequency (MHz)	Antenna polarization (H/V)	Emission (dBuV/m)		Band edge Limit (dBuV/m)	
		PEAK	AV	PEAK	AV
<2400	H	54.56	43.92	74.00	54.00
<2400	V	54.72	44.67	74.00	54.00
>2483.5	H	53.90	43.21	74.00	54.00
>2483.5	V	54.49	43.37	74.00	54.00

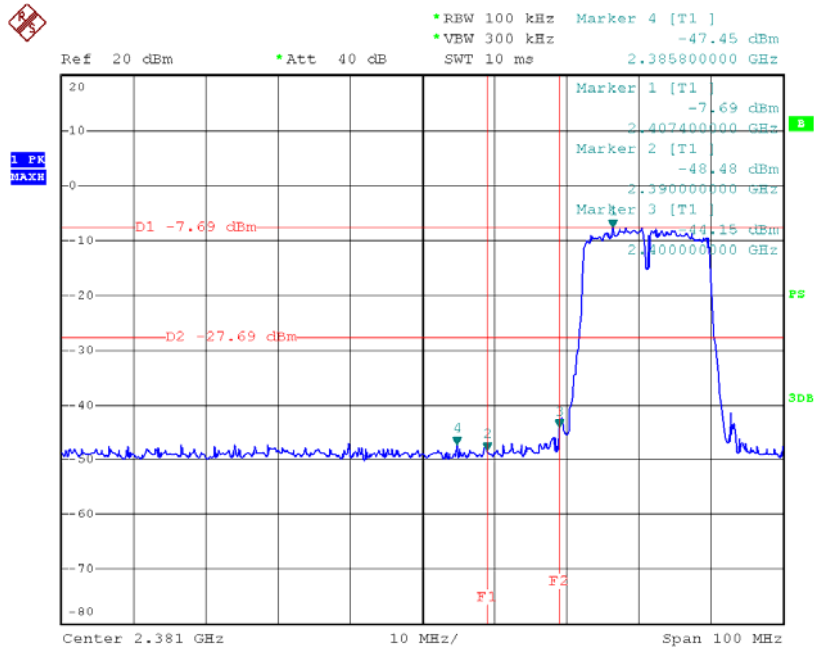

Date: 14.AUG.2012 17:18:26

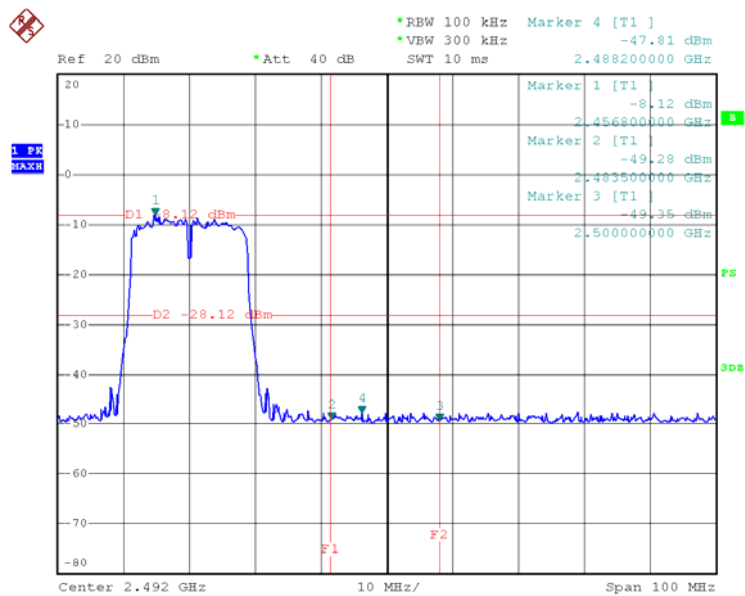

Date: 14.AUG.2012 16:57:58

Spectrum Detector: PK
 Temperature : 28 °C

Test Date : August 14, 2012
 Humidity : 65 %

802.11n (HT40) Mode

1. Conducted Test

Frequency (MHz)	Peak Power Output(dBm)	Emission Read Value(dBm)	Result of Band edge(dBc)	Band edge Limit(dBc)
<2400	-10.71	-47.13	36.42	>20dBc
>2483.5	-10.44	-47.13	41.64	>20dBc

2. Radiated emission test

Frequency (MHz)	Antenna polarization (H/V)	Emission (dBuV/m)		Band edge Limit (dBuV/m)	
		PEAK	AV	PEAK	AV
<2400	H	53.92	43.46	74.00	54.00
<2400	V	53.70	44.33	74.00	54.00
>2483.5	H	53.03	43.32	74.00	54.00
>2483.5	V	53.42	43.21	74.00	54.00

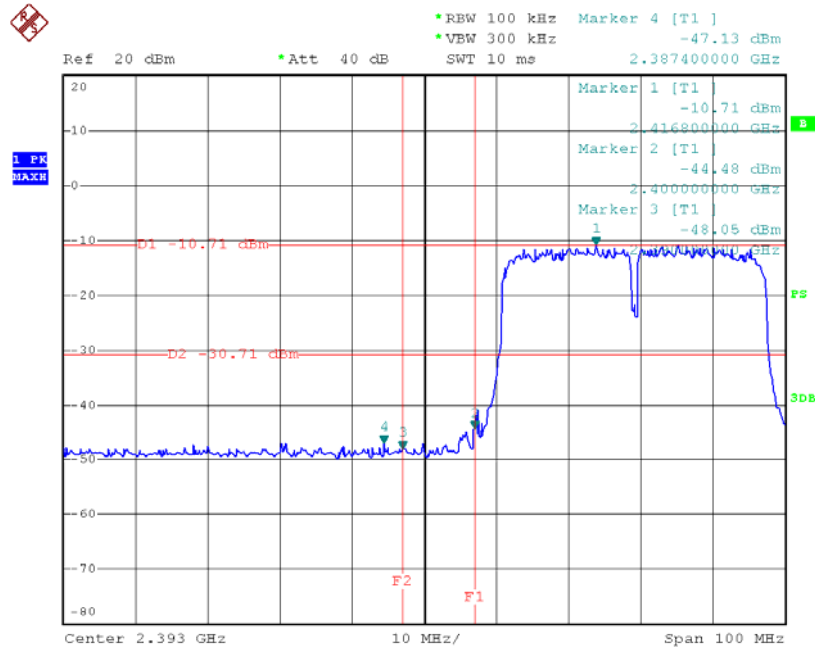

Date: 14.AUG.2012 17:34:56

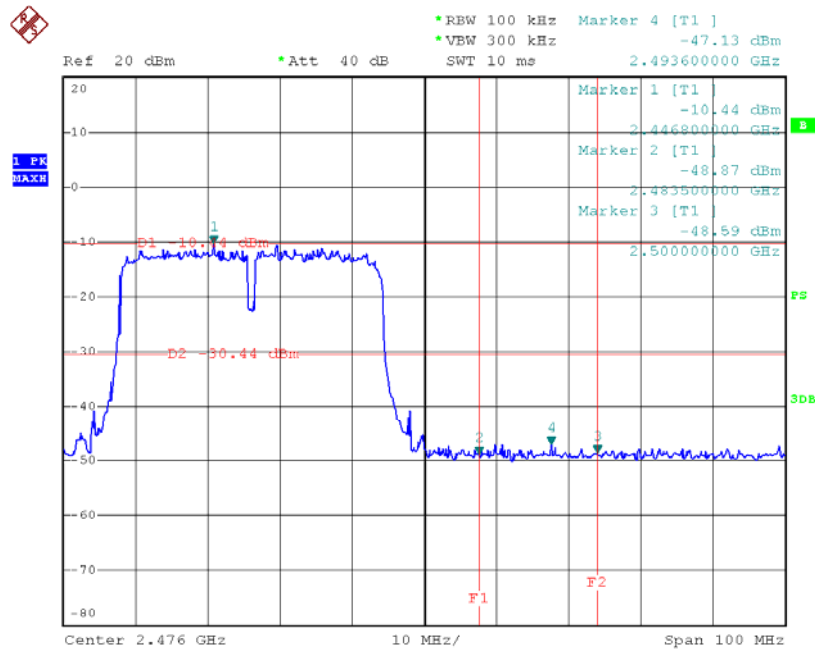

Date: 14.AUG.2012 17:50:33

6. Bandwidth Test

6.1 Test Standard and Limit

- 8.1.1 Test Standard
FCC Part 15.247 (a)(2)
- 8.1.2 Test Limit

FCC Part 15 Subpart C(15.247)		
Test Item	Limit	Frequency Range(MHz)
Bandwidth	≥ 500 KHz (6dB bandwidth)	2400~2483.5

6.2 Test Setup

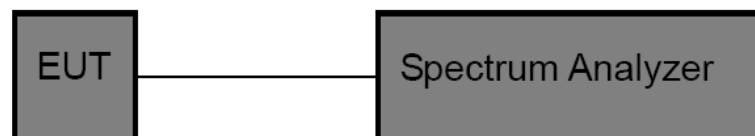

6.3 Test Procedure

- (1) The EUT was directly connected to the spectrum analyzer and antenna output port as show in the block diagram above.
- (2) The bandwidth is measured at an amplitude level reduced 6dB from the reference level. The reference level is the level of the highest amplitude signal observed from the transmitter at the fundamental frequency. Once the reference level is established, the equipment is conditioned with typical modulating signal to produce the worst –case (i.e the widest) bandwidth.
- (3) Measure the channel separation the spectrum analyzer was set to Resolution Bandwidth:100 kHz, and Video Bandwidth:300 kHz, Detector: Peak, Sweep Time set auto.

6.4 EUT Operating Condition

The EUT was set to continuously transmitting in each mode and low, middle and high channel for the test.

6.5 Test Equipment

Description	Manufacturer	Model No.	Serial No.	Cal. Date	Cal. Date
Spectrum Analyzer	ROHDE& SCHWARZ	FSEA20	DE25181	2012-08-07	2013-08-06

6.6 Test Data

802.11b			
Channel frequency (MHz)	6dB Bandwidth (MHz)	99% Bandwidth (MHz)	Limit
2412	12.12	14.76	>=500 kHz
2437	12.04	14.72	>=500 kHz
2462	12.08	14.68	>=500 kHz

2412 MHz

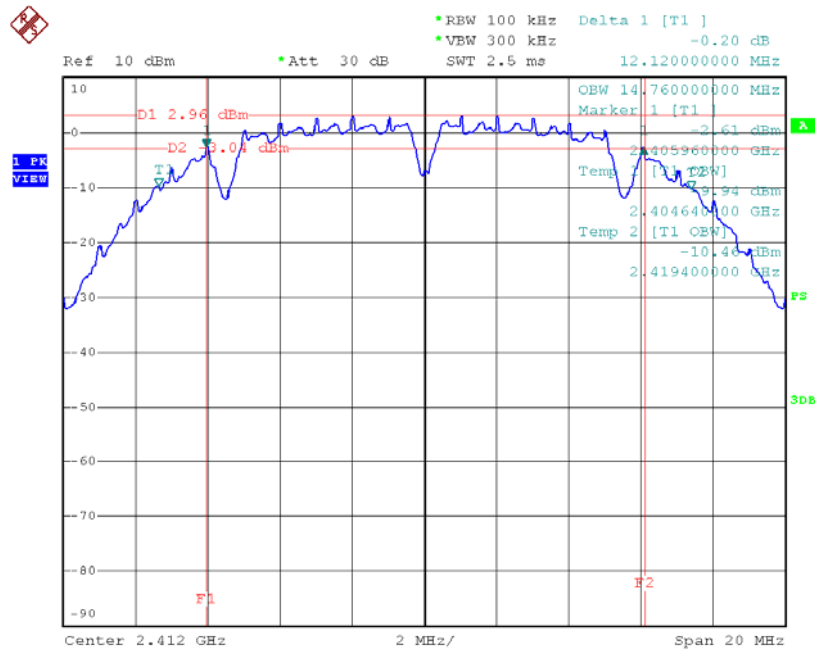

Date: 23.AUG.2012 11:21:09

2437 MHz

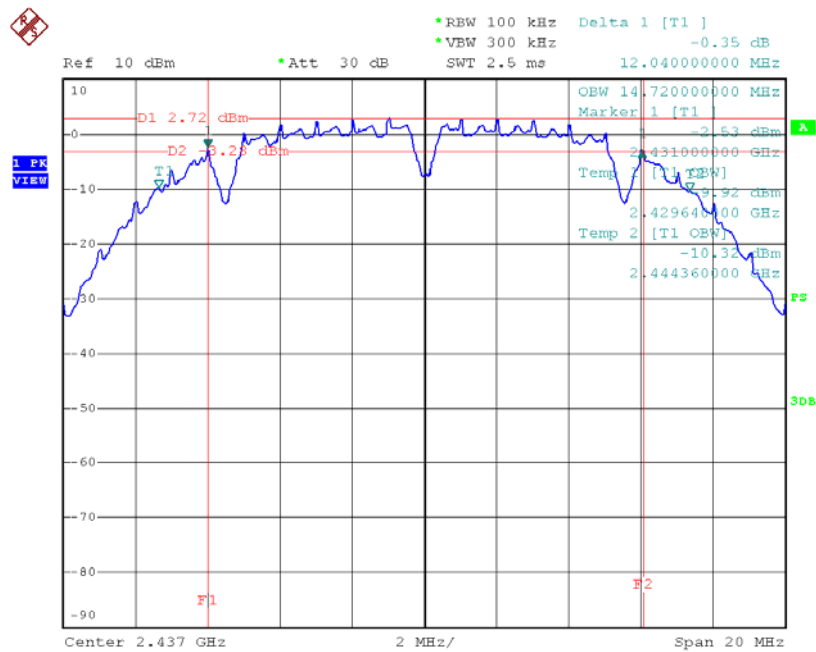

Date: 23.AUG.2012 11:19:42

2462 MHz

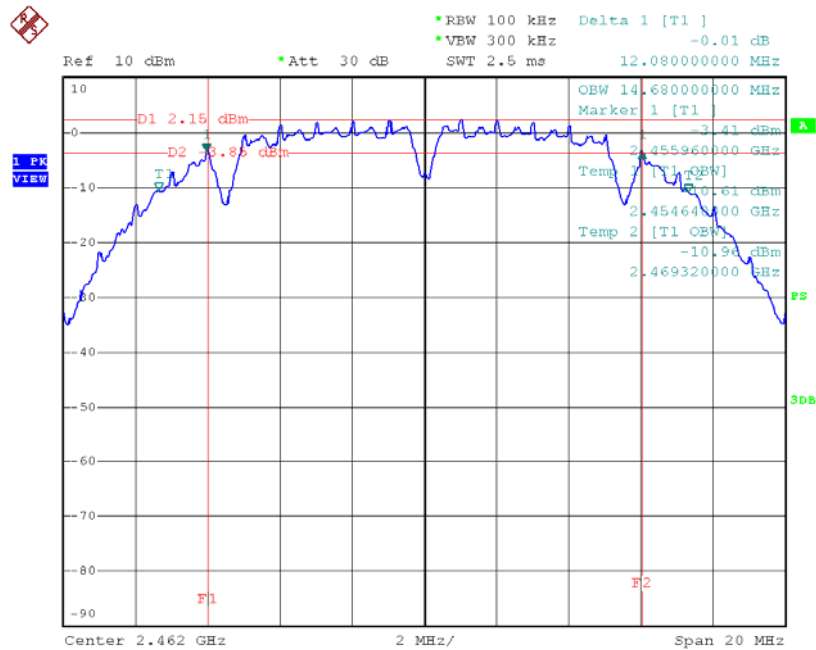

Date: 23.AUG.2012 11:18:00

802.11g			
Channel frequency (MHz)	6dB Bandwidth (MHz)	99% Bandwidth (MHz)	Limit
2412	16.44	16.40	>=500 kHz
2437	16.44	16.40	>=500 kHz
2462	16.52	16.36	>=500 kHz

2412 MHz

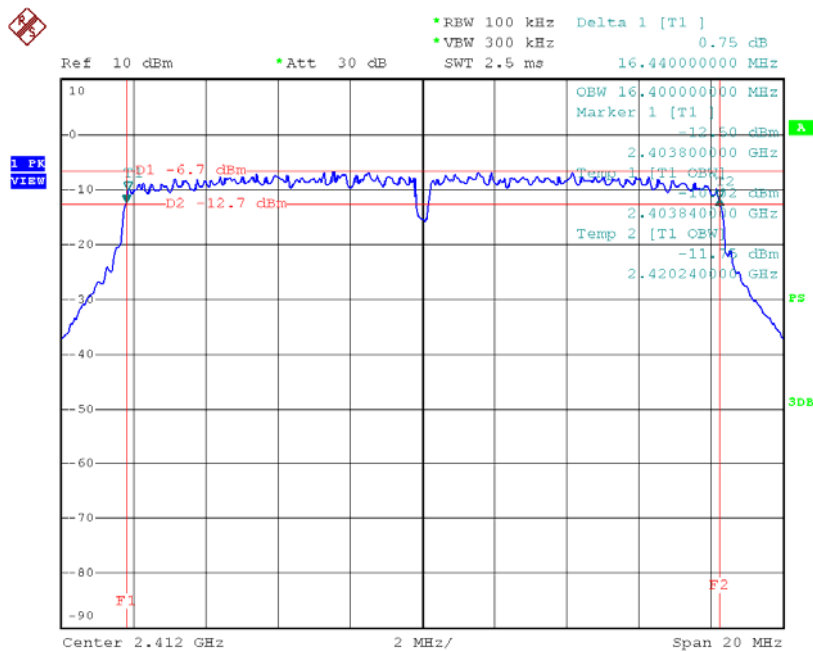

Date: 23.AUG.2012 11:24:01

2437 MHz

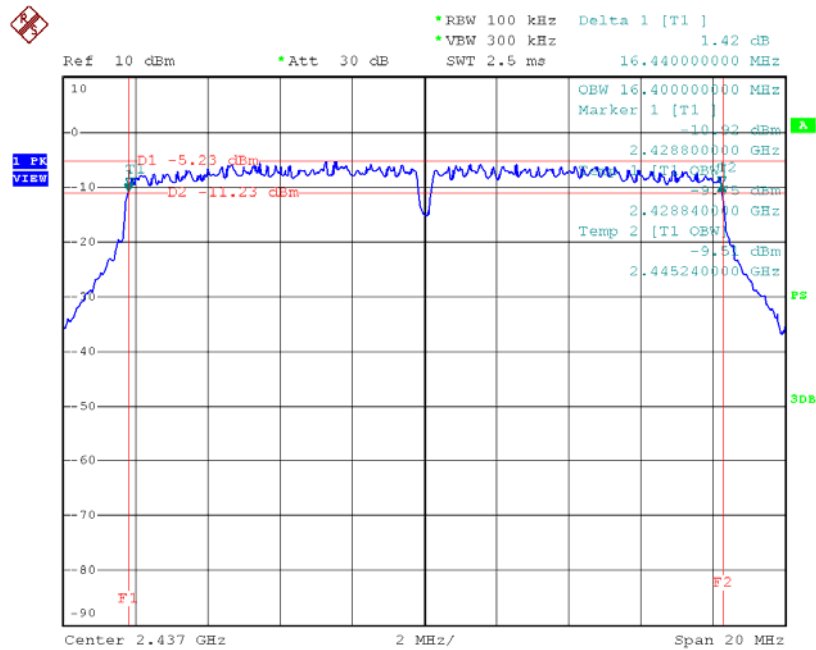

Date: 23.AUG.2012 11:27:10

2462 MHz

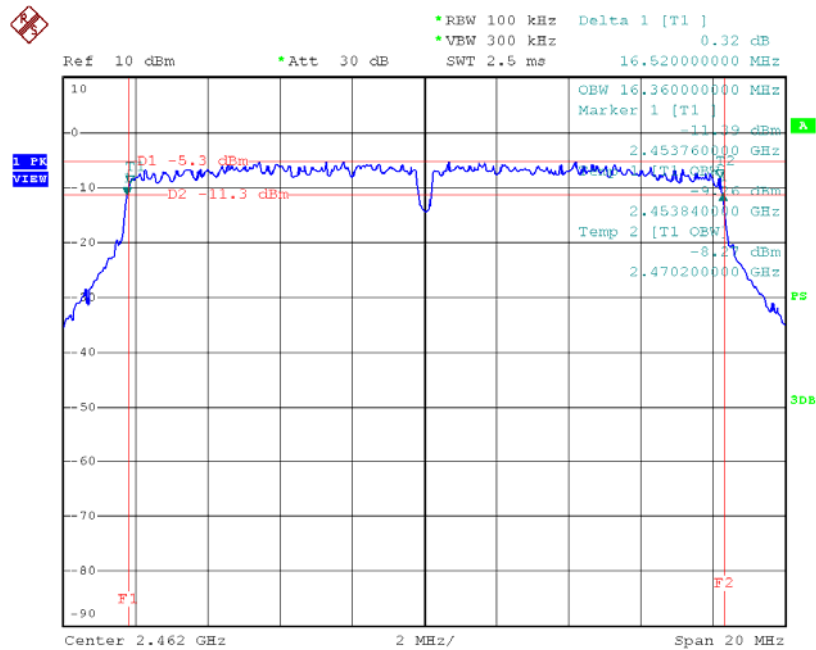

Date: 23.AUG.2012 11:29:18

802.11n(HT20)			
Channel frequency (MHz)	6dB Bandwidth (MHz)	99% Bandwidth (MHz)	Limit
2412	17.56	17.52	>=500 kHz
2437	17.60	17.52	>=500 kHz
2462	17.56	17.52	>=500 kHz

2412 MHz

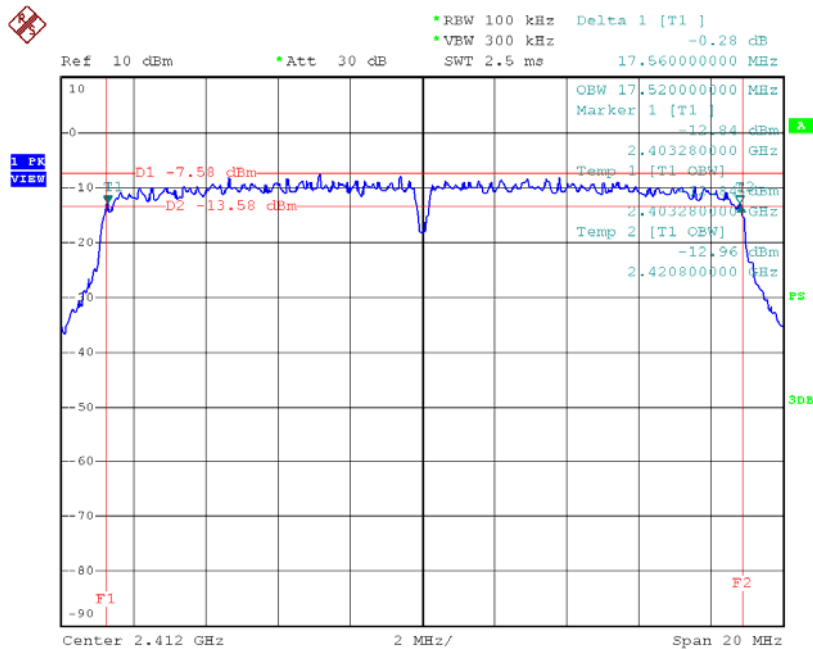

Date: 23.AUG.2012 11:36:29

2437 MHz

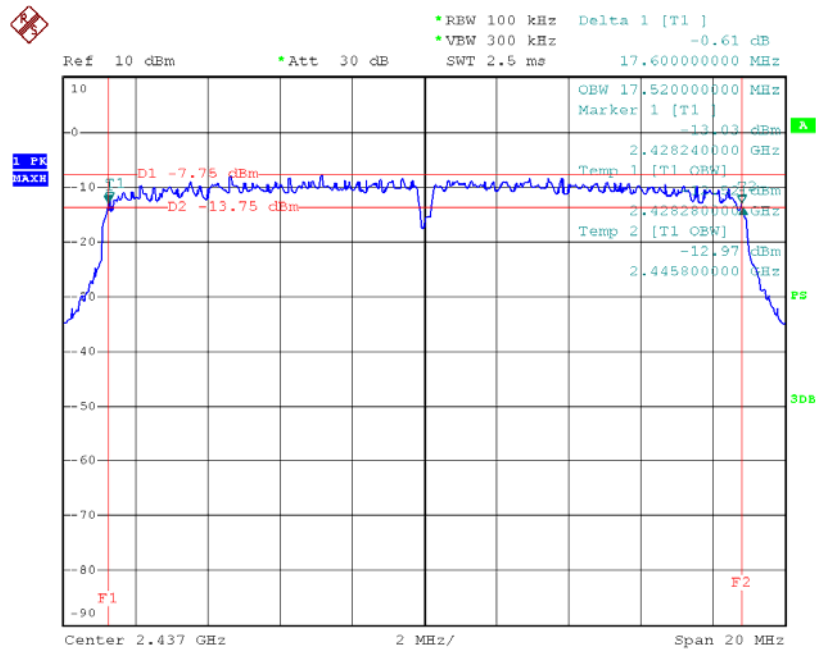

Date: 23.AUG.2012 11:35:06

2462 MHz

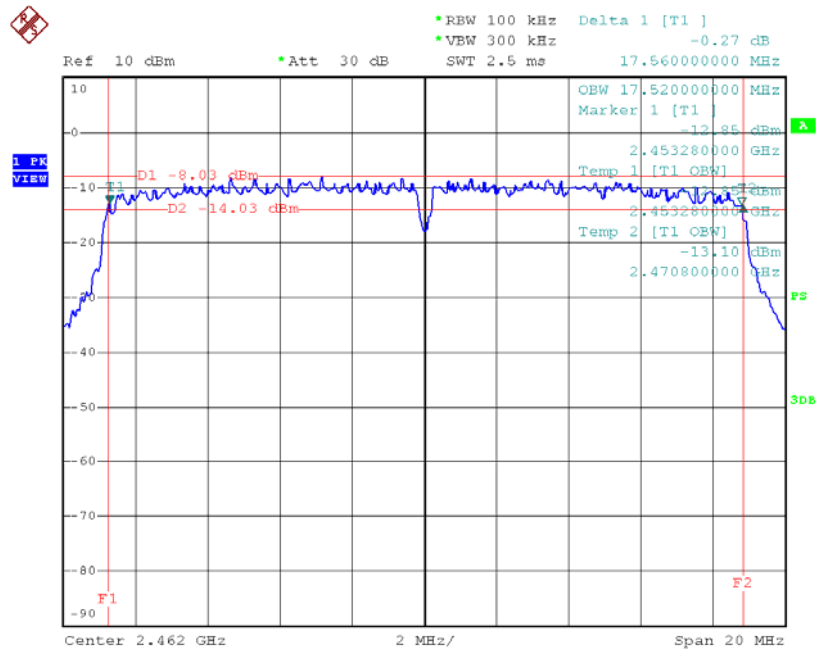

Date: 23.AUG.2012 11:33:24

802.11n(HT40)			
Channel frequency (MHz)	6dB Bandwidth (MHz)	99% Bandwidth (MHz)	Limit
2422	35.76	35.76	>=500 kHz
2437	35.72	35.76	>=500 kHz
2452	36.00	35.76	>=500 kHz

2422 MHz

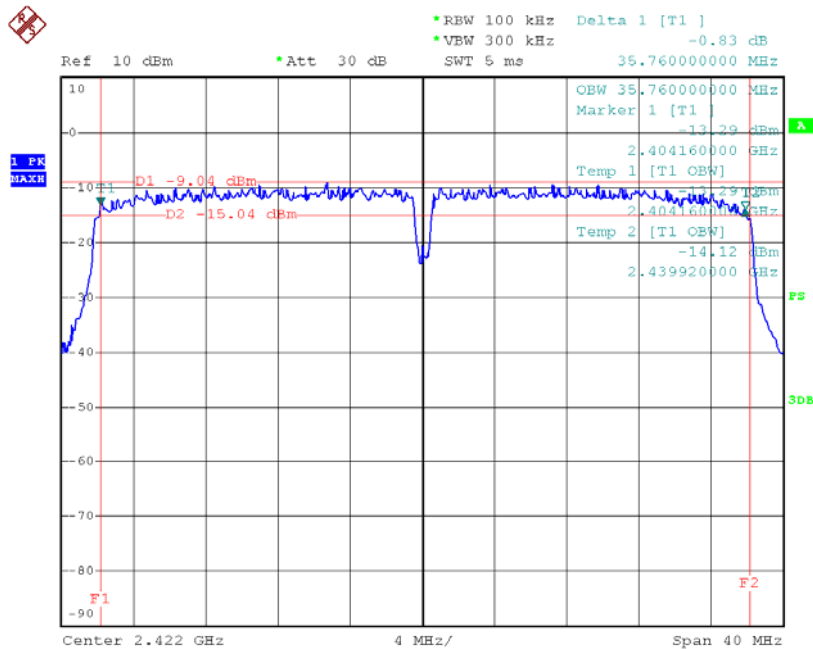

Date: 23.AUG.2012 11:50:11

2437 MHz

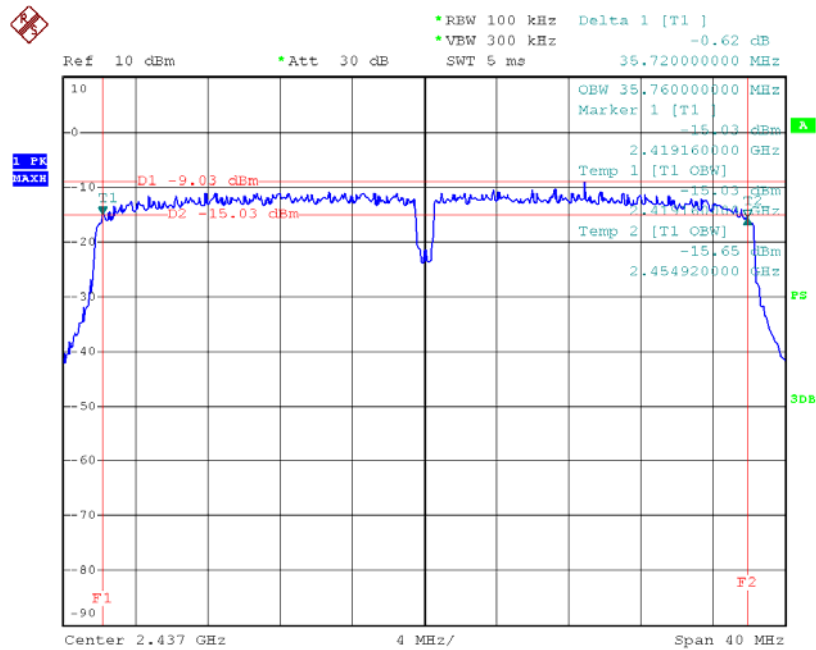

Date: 23.AUG.2012 11:53:07

2452 MHz

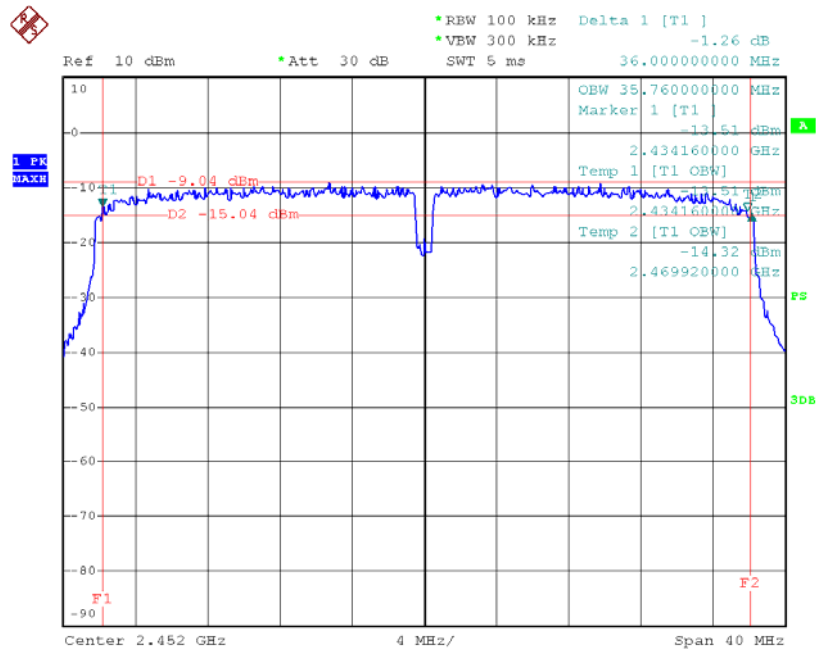

Date: 23.AUG.2012 11:56:18

7. Peak Output Power Test

7.1 Test Standard and Limit

- 9.1.1 Test Standard
FCC Part 15.247 (b)
- 9.1.2 Test Limit

FCC Part 15 Subpart C(15.247)		
Test Item	Limit	Frequency Range(MHz)
Peak Output Power	1 Watt or 30 dBm	2400~2483.5

7.2 Test Setup

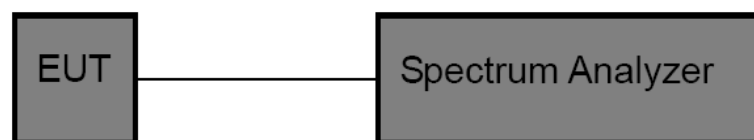

7.3 Test Procedure

The EUT was directly connected to the Spectrum Analyzer and antenna output port as show in the block diagram above.

7.4 EUT Operating Condition

The EUT was set to continuously transmitting in the max power during the test.

7.5 Test Equipment

Description	Manufacturer	Model No.	Serial No.	Cal. Date	Cal. Date
EMI Test Receiver	Rohde& Schwarz	ESCI	101122	2012-04-11	2013-04-10

7.6 Test Data

801.11b Mode			
Test Channel	Frequency (MHz)	Peak Output Power (dBm)	Limit (dBm)
CH01	2412	17.21	30
CH 06	2437	17.57	30
CH11	2462	17.93	30

2412 MHz

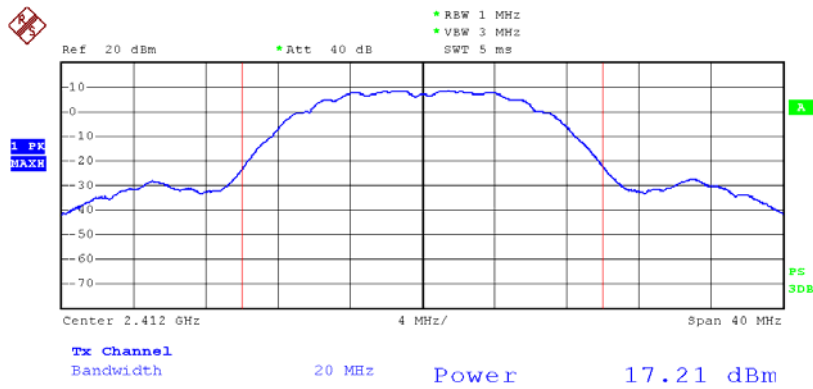

Date: 14.AUG.2012 15:31:21

2437 MHz

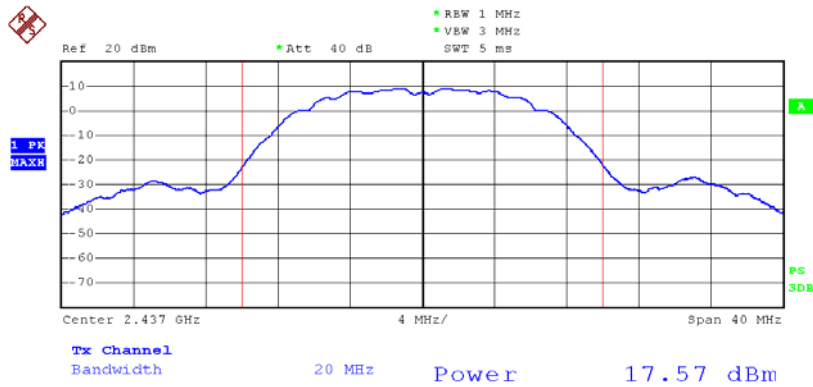

Date: 14.AUG.2012 15:45:20

2462 MHz

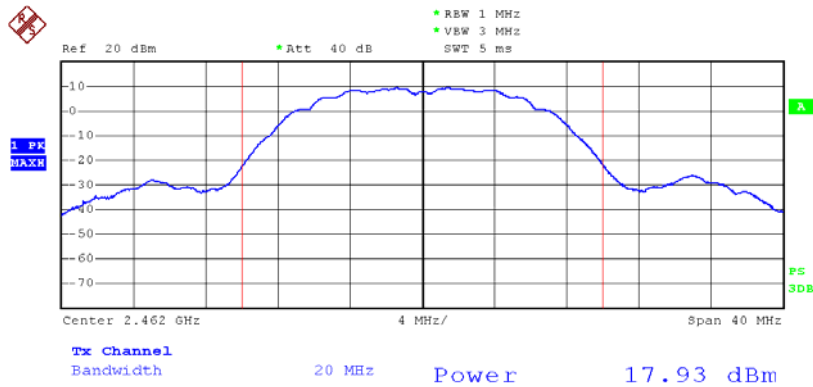

Date: 14.AUG.2012 15:51:02

801.11g Mode			
Test Channel	Frequency (MHz)	Peak Output Power (dBm)	Limit (dBm)
CH01	2412	14.82	30
CH 06	2437	14.98	30
CH11	2462	14.36	30

2412 MHz

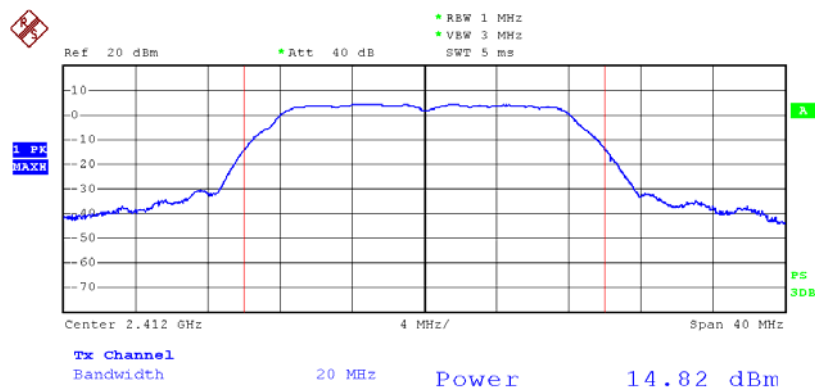

Date: 14.AUG.2012 16:03:33

2437 MHz

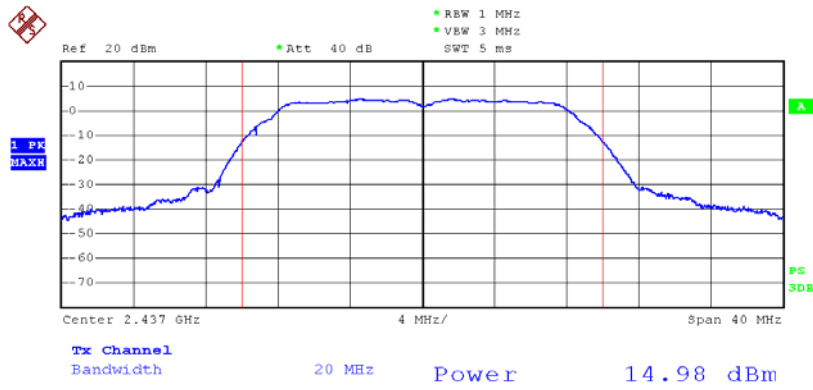

Date: 14.AUG.2012 16:16:21

2462 MHz

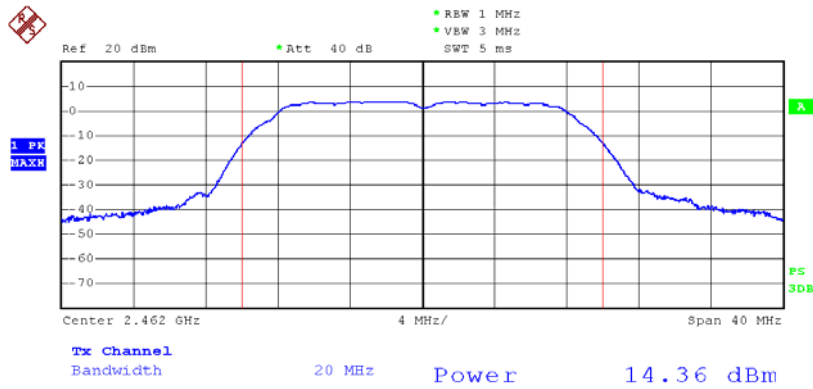

Date: 14.AUG.2012 16:25:40

801.11n(HT20) Mode			
Test Channel	Frequency (MHz)	Peak Output Power (dBm)	Limit (dBm)
CH01	2412	13.99	30
CH 06	2437	13.47	30
CH11	2462	13.51	30

2412 MHz

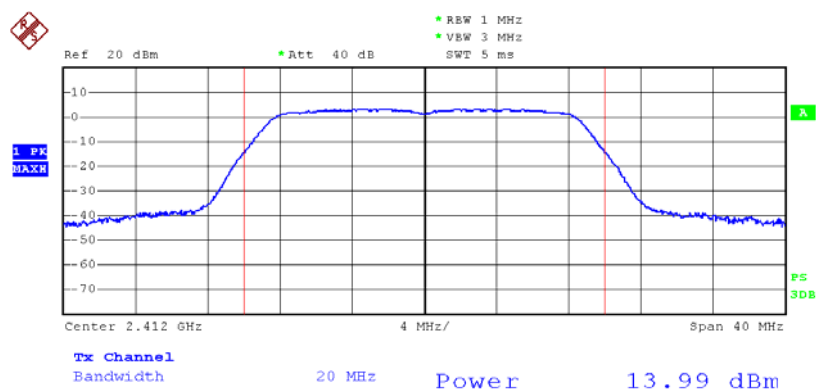

Date: 14.AUG.2012 17:07:41

2437 MHz

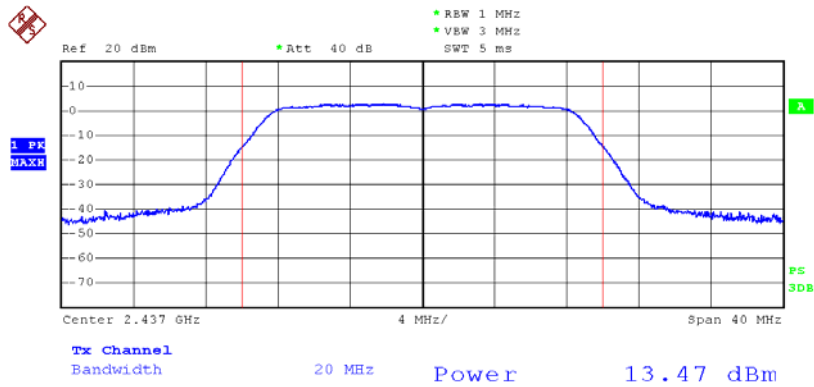

Date: 14.AUG.2012 16:59:40

2462 MHz

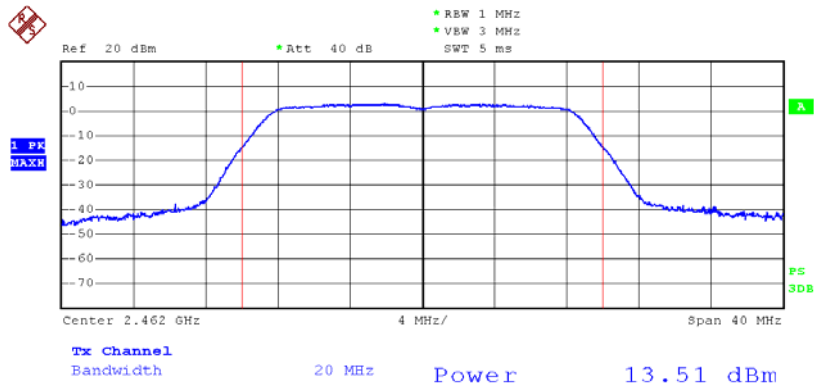

Date: 14.AUG.2012 16:40:50

801.11n(HT40) Mode			
Test Channel	Frequency (MHz)	Peak Output Power (dBm)	Limit (dBm)
CH03	2422	13.27	30
CH 06	2437	13.37	30
CH09	2452	13.25	30

2422 MHz

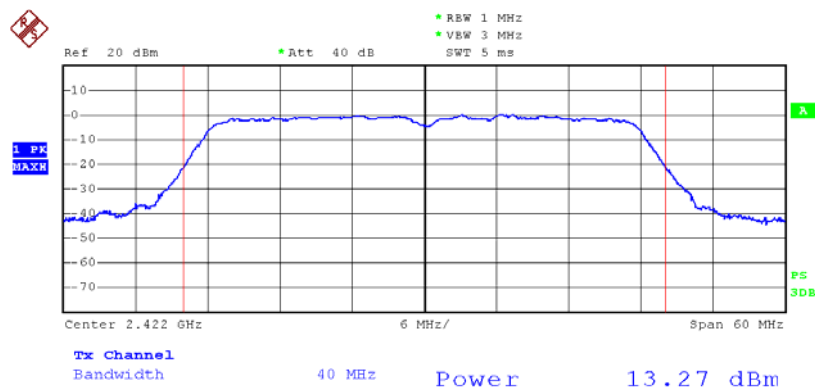

Date: 14.AUG.2012 17:20:28

2437 MHz

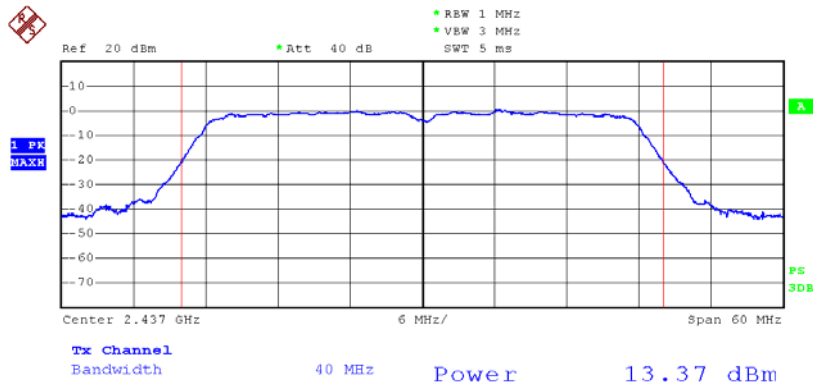

Date: 14.AUG.2012 17:36:06

2452 MHz

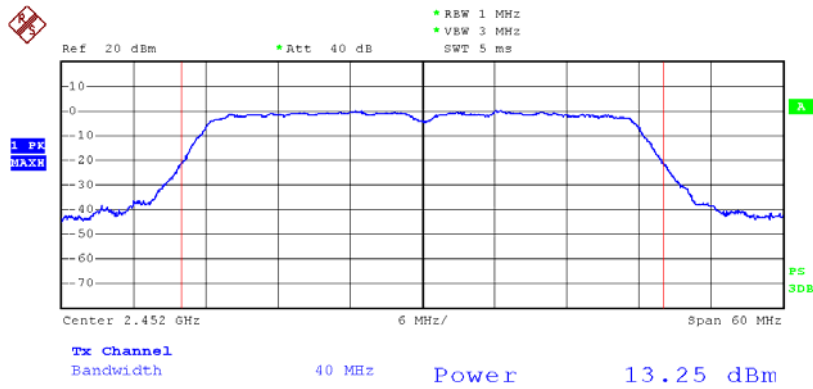

Date: 14.AUG.2012 17:42:55

8. Power Spectral Density Test

8.1 Test Standard and Limit

8.1.1 Test Standard

FCC Part 15.247 (e)

8.1.2 Test Limit

FCC Part 15 Subpart C(15.247)		
Test Item	Limit	Frequency Range(MHz)
Power Spectral Density	8dBm(in any 3 kHz)	2400~2483.5

8.2 Test Setup

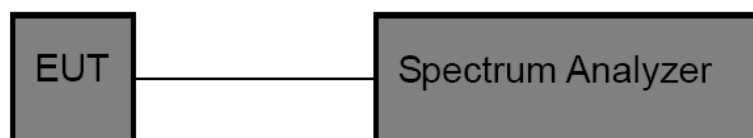

8.3 Test Procedure

- (1) The EUT was directly connected to the spectrum analyzer and antenna output port as show in the block diagram above.
- (2) Measure the spectral power density the spectrum analyzer was set to Resolution Bandwidth=100 kHz, and Video Bandwidth \geq 300 kHz, Detector: Peak, Span to 5%~30% greater than EBW, Sweep time auto.
- (3) Scale the observed power level to an equivalent value in 3 kHz by adjusting (reducing) the measured power by a BWCF=-15.2 dB.

8.4 EUT Operating Condition

The EUT was set to continuously transmitting in each mode and low, middle and high channel for the test.

8.5 Test Equipment

Description	Manufacturer	Model No.	Serial No.	Cal. Date	Cal. Date
Spectrum Analyzer	ROHDE& SCHWARZ	FSEA20	DE25181	2012-08-07	2013-08-06

8.6 Test Data

801.11b Mode				
Test Channel	Frequency (MHz)	Power Level (100 kHz)	Power Density (3 kHz/dBm)	Limit (dBm)
CH 01	2412	2.52	-17.72	8
CH 06	2437	2.55	-17.75	8
CH 11	2462	2.05	-17.25	8

Note: Power Density=Power Level-15.2

2412 MHz

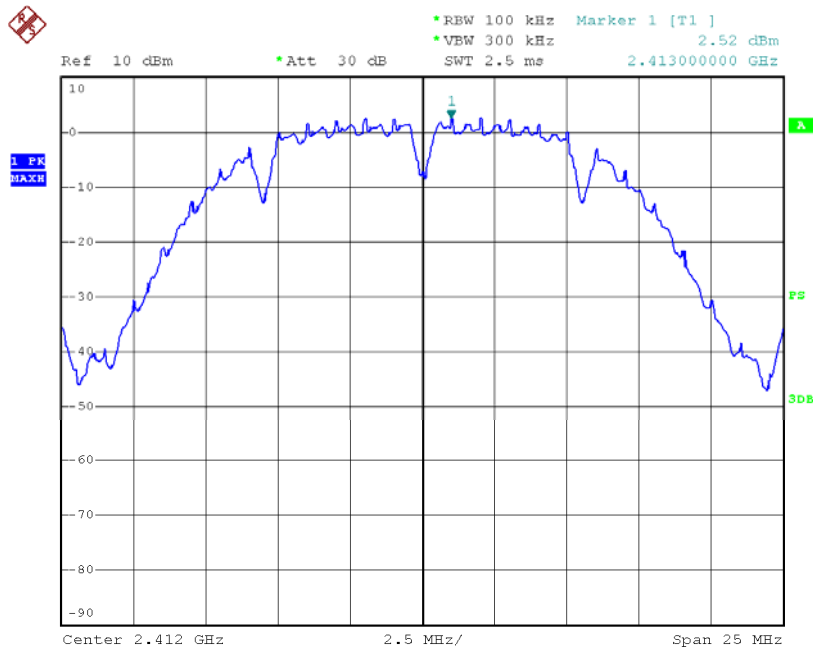

Date: 23.AUG.2012 11:15:07

2437 MHz

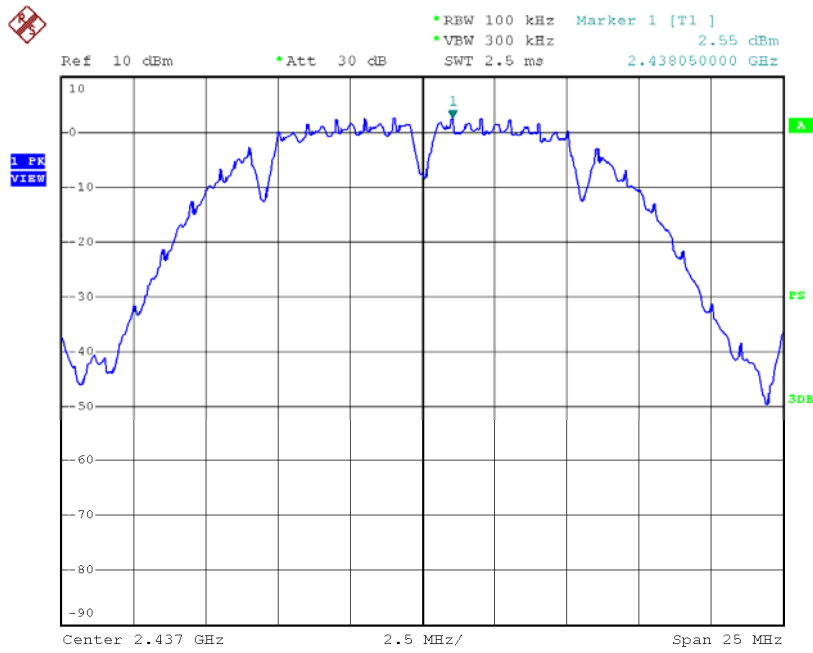

Date: 23.AUG.2012 11:16:10

2462 MHz

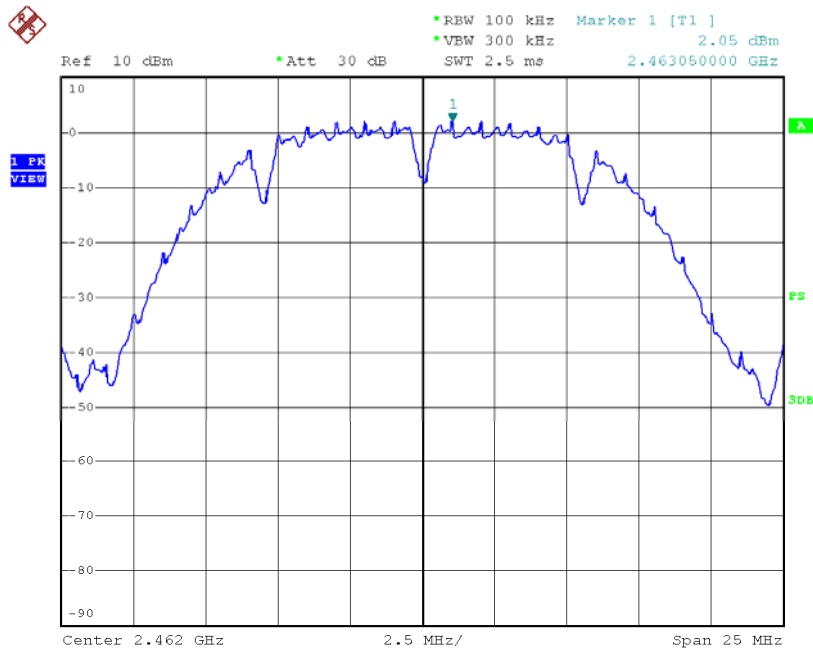

Date: 23.AUG.2012 11:16:58

801.11g Mode				
Test Channel	Frequency (MHz)	Power Level (100 kHz)	Power Density (3 kHz/dBm)	Limit (dBm)
CH 01	2412	-6.02	-21.22	8
CH 06	2437	-6.45	-21.65	8
CH 11	2462	-6.06	-21.26	8

Note: Power Density=Power Level-15.2

2412 MHz

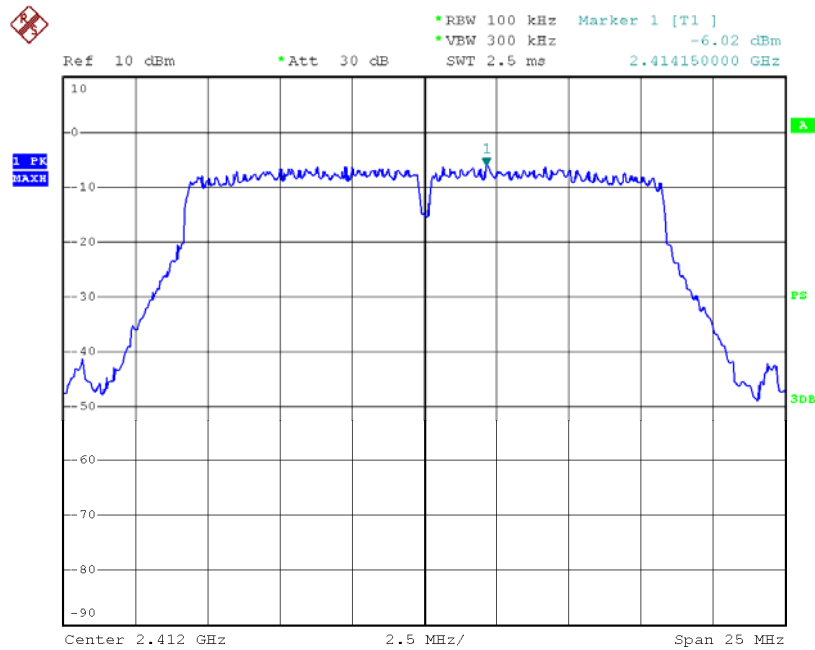

Date: 23.AUG.2012 11:45:47

2437 MHz

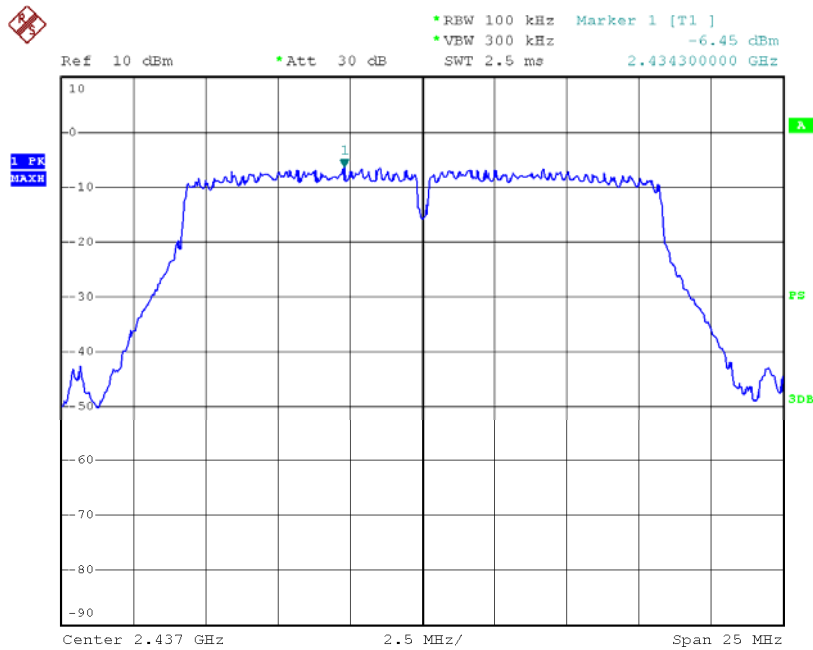

Date: 23.AUG.2012 11:44:50

2462 MHz

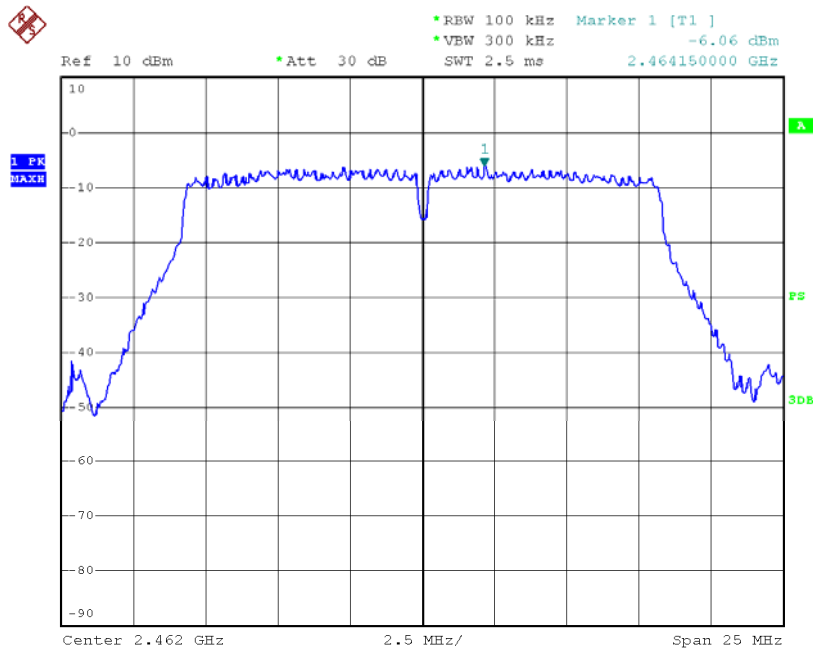

Date: 23.AUG.2012 11:43:44

801.11n(HT20) Mode				
Test Channel	Frequency (MHz)	Power Level (100 kHz)	Power Density (3 kHz/dBm)	Limit (dBm)
CH 01	2412	-7.54	-22.74	8
CH 06	2437	-7.53	-22.73	8
CH 11	2462	-7.73	-22.93	8

Note: Power Density=Power Level-15.2

2412 MHz

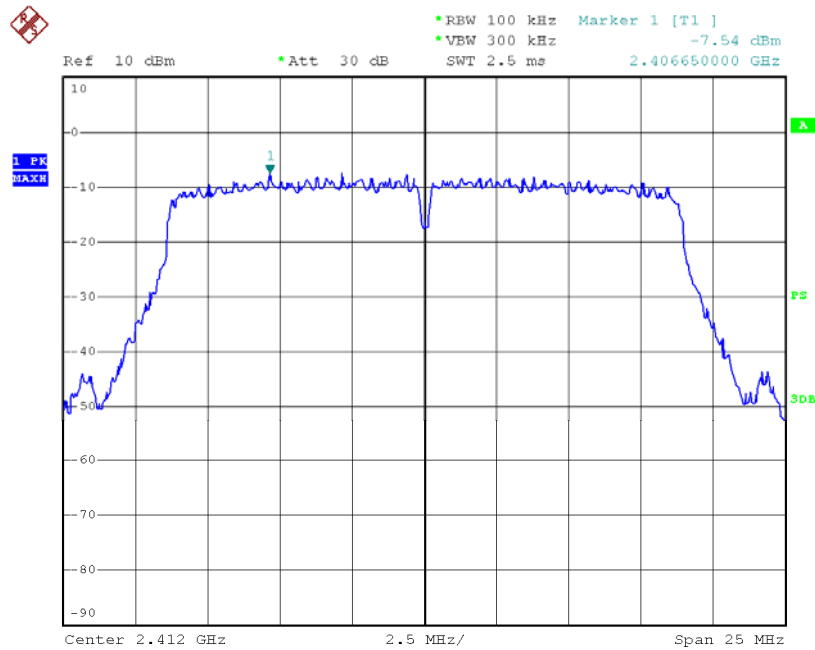

Date: 23.AUG.2012 11:37:17

2437 MHz

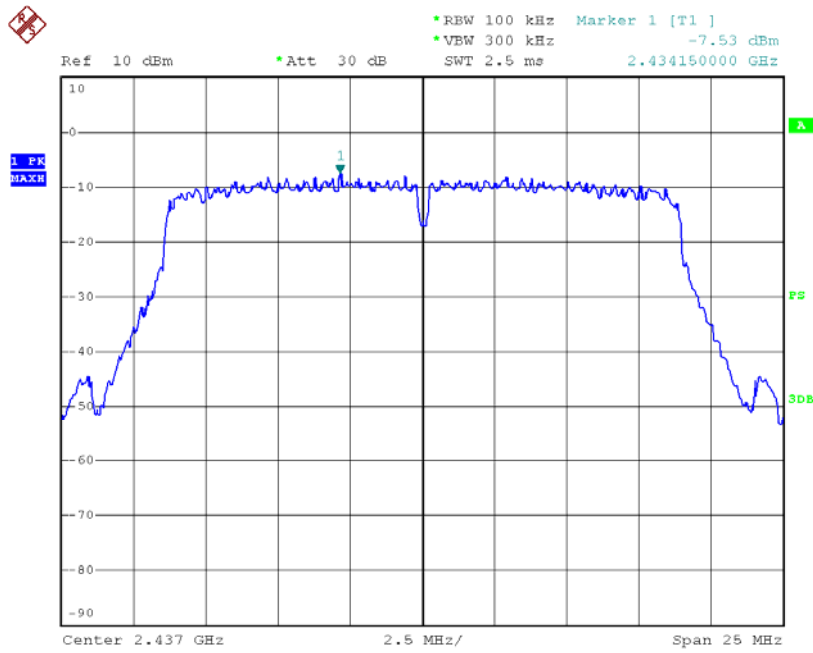

Date: 23.AUG.2012 11:38:41

2462 MHz

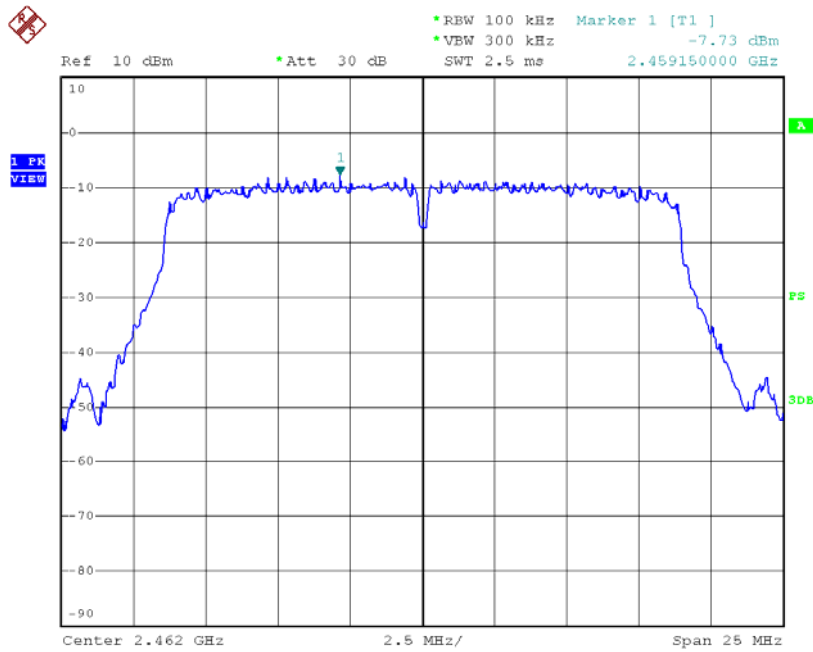

Date: 23.AUG.2012 11:40:55

801.11n(HT40) Mode				
Test Channel	Frequency (MHz)	Power Level (100 kHz)	Power Density (3 kHz/dBm)	Limit (dBm)
CH 03	2422	-10.43	-25.63	8
CH 06	2437	-9.03	-24.23	8
CH 09	2452	-9.47	-24.67	8

Note: Power Density=Power Level-15.2

2422 MHz

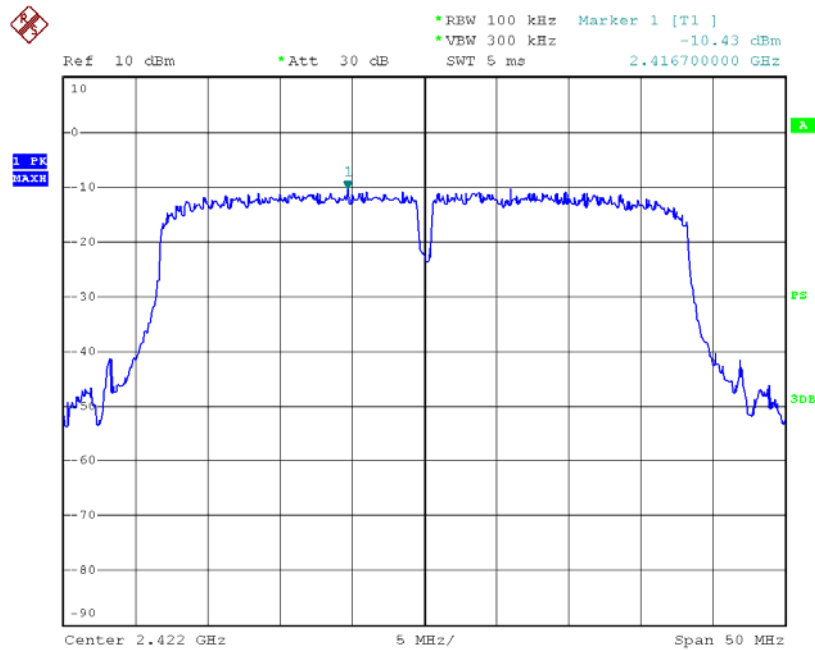

Date: 23.AUG.2012 11:48:09

2437 MHz

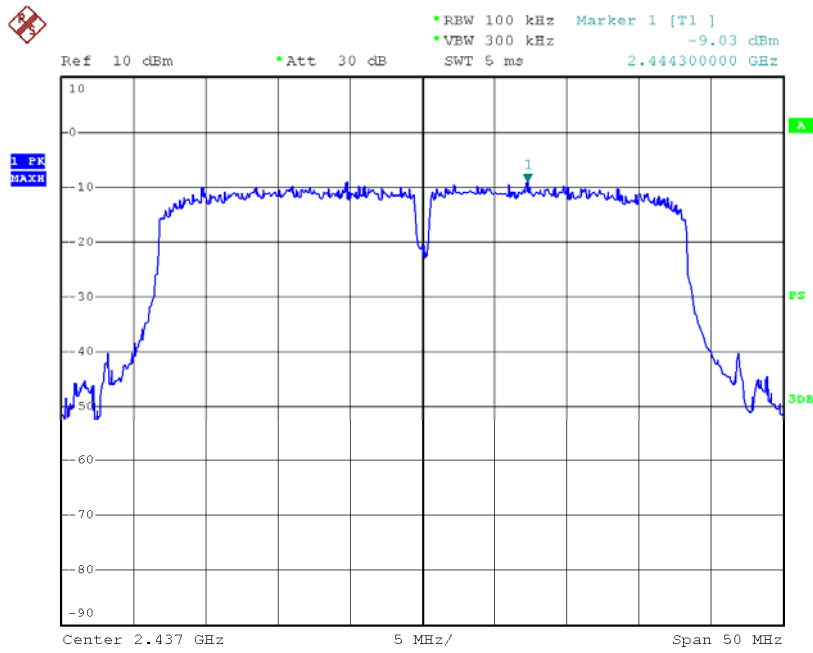

Date: 23.AUG.2012 11:53:45

2452 MHz

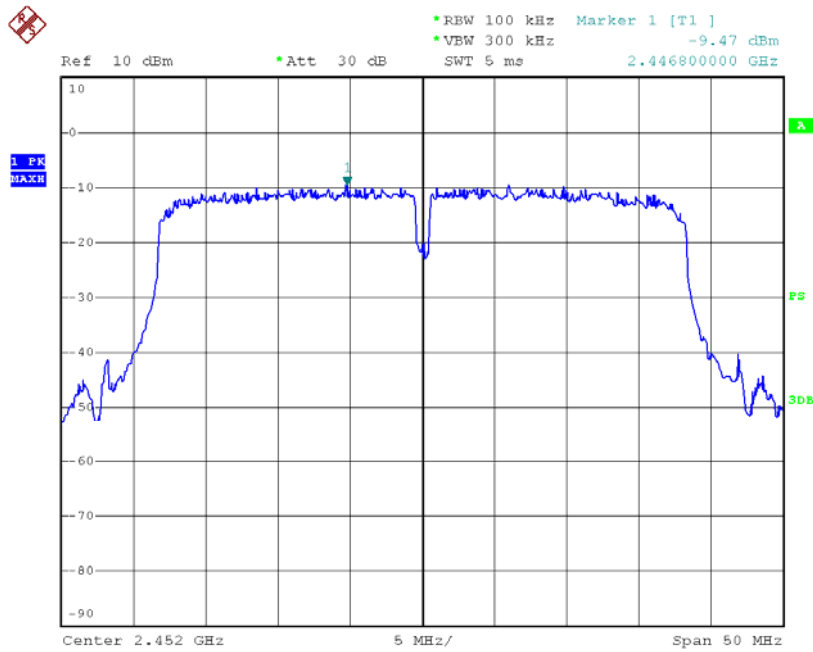

Date: 23.AUG.2012 11:55:14

9. Antenna Conducted Spurious Emission

9.1 Test Standard and Limit

10.1.1 Test Standard

FCC Part 15.247 (c)

10.1.2 Test Limit

In any 100 kHz bandwidth outside the frequency band in which the spread spectrum or digitally modulated intentional radiator is operating, the radio frequency power that is produced by the intentional radiator shall be at least 20 dB below that in the 100 kHz bandwidth within the band that contains the highest level of the desired power. In case the emission fall within the restricted band specified on 15.205(a), then the 15.209(a) limit in the table below has to be followed.

Frequencies (MHz)	Field Strength (microvolt/meter)	Measurement Distance (meters)
0.009~0.490	2400/F(KHz)	300
0.490~1.705	24000/F(KHz)	30
1.705~30.0	30	30
30~88	100	3
88~216	150	3
216~960	200	3
Above~960	500	3

(2)If the peak output power procedure is used to measure the fundamental emission power to demonstrate compliance to 15.247(b)(3) requirements, then the peak conducted output power measured within any 100 kHz outside the authorized frequency band shall be attenuated by at least 20 dB relative to the maximum measured in-band peak PSD level.

9.2 Test Setup

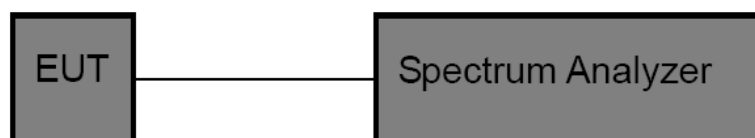

9.3 Test Procedure

- (1) The EUT was directly connected to the spectrum analyzer and antenna output port as show in the block diagram above.

(2) Spectrum Setting:

RBW=100 KHz, VBW=300 KHz.

Frequency range: from 30MHz to 26.5 GHz.

9.4 EUT Operating Condition

The EUT was set to continuously transmitting in the max power during the test.

9.5 Test Equipment

Description	Manufacturer	Model No.	Serial No.	Cal. Date	Cal. Date
Spectrum Analyzer	ROHDE& SCHWARZ	FSEA20	DE25181	2012-08-07	2013-08-06

9.6 Test Data

Unwanted Emission Level of Non-Restricted Frequency Bands

801.11b Mode				
Test Channel	Max. Emission Level (dBm)	Power Density (dBm)	Limit (dBm)	Result
CH 01	-38.57	-17.72	-37.72	Compliance
CH 06	-39.73	-17.75	-37.75	Compliance
CH 11	-38.91	-17.25	-37.25	Compliance

801.11g Mode				
Test Channel	Max. Emission Level (dBm)	Power Density (dBm)	Limit (dBm)	Result
CH 01	-53.99	-21.22	-41.22	Compliance
CH 06	-53.62	-21.65	-41.65	Compliance
CH 11	-54.58	-21.26	-41.26	Compliance

801.11n(HT20) Mode				
Test Channel	Max. Emission Level (dBm)	Power Density (dBm)	Limit (dBm)	Result
CH 01	-53.94	-22.74	-42.74	Compliance
CH 06	-53.05	-22.73	-42.73	Compliance
CH 11	-53.49	-22.93	-42.93	Compliance

801.11n(HT40) Mode				
Test Channel	Max. Emission Level (dBm)	Power Density (dBm)	Limit (dBm)	Result
CH 01	-54.10	-25.63	-45.63	Compliance
CH 06	-53.80	-24.23	-44.23	Compliance
CH 11	-54.03	-24.67	-44.67	Compliance

802.11b Mode TX CH 01 2412MHz

Above 1 GHz

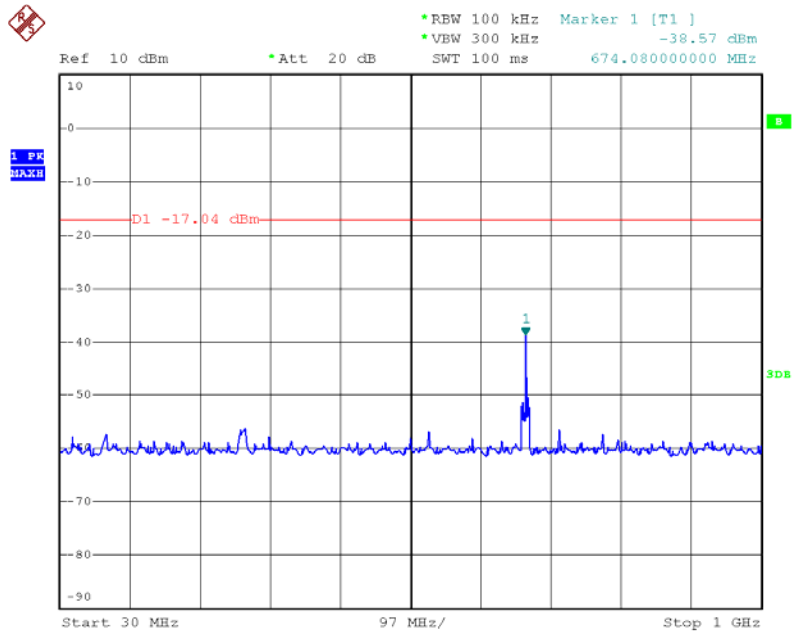

Date: 18.AUG.2012 15:10:35

Bellow 1 GHz

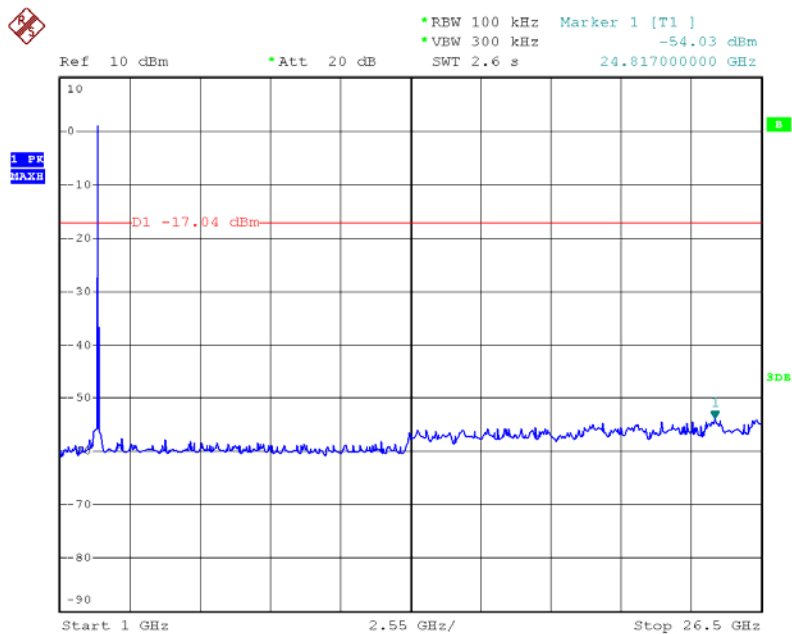

Date: 18.AUG.2012 15:11:28

802.11b Mode

TX CH 06 2437MHz

Above 1 GHz

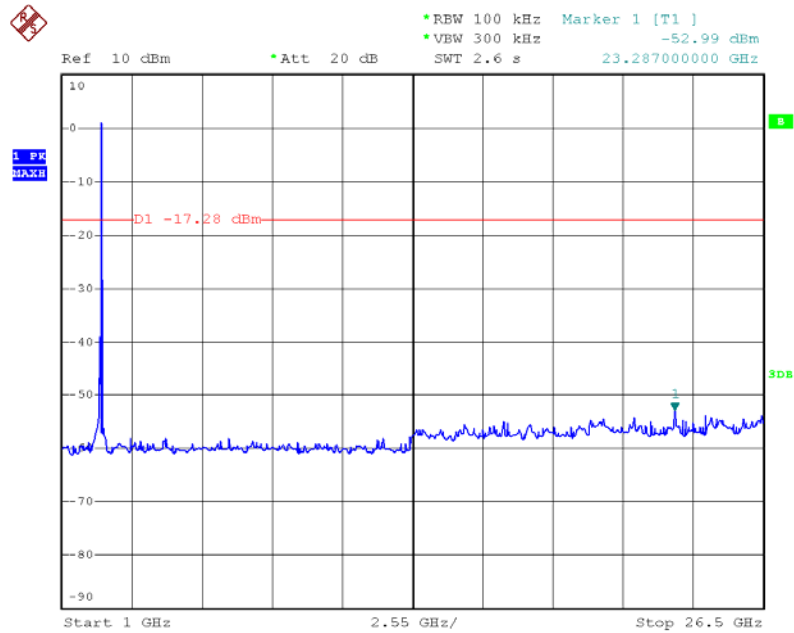

Date: 18.AUG.2012 15:11:58

Bellow 1 GHz

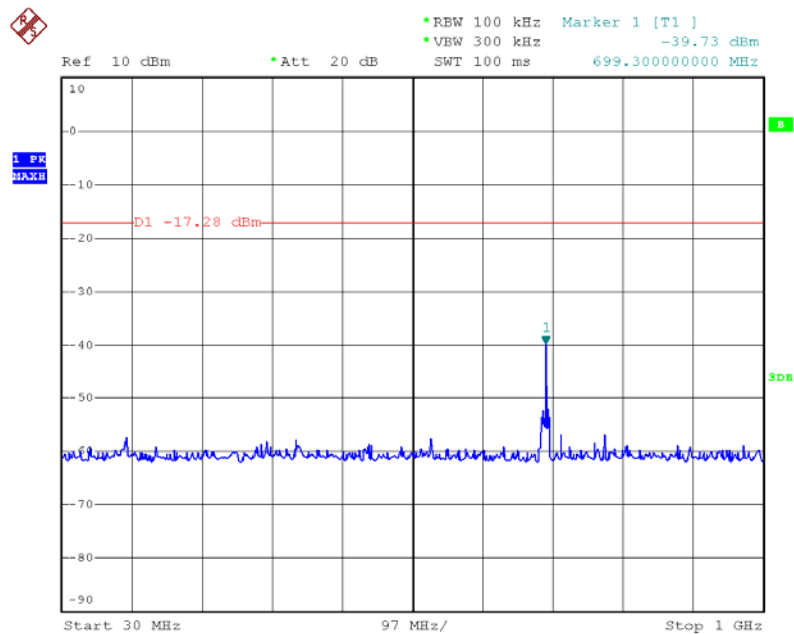

Date: 18.AUG.2012 15:12:12

802.11b Mode

TX CH 11 2462MHz

Above 1 GHz

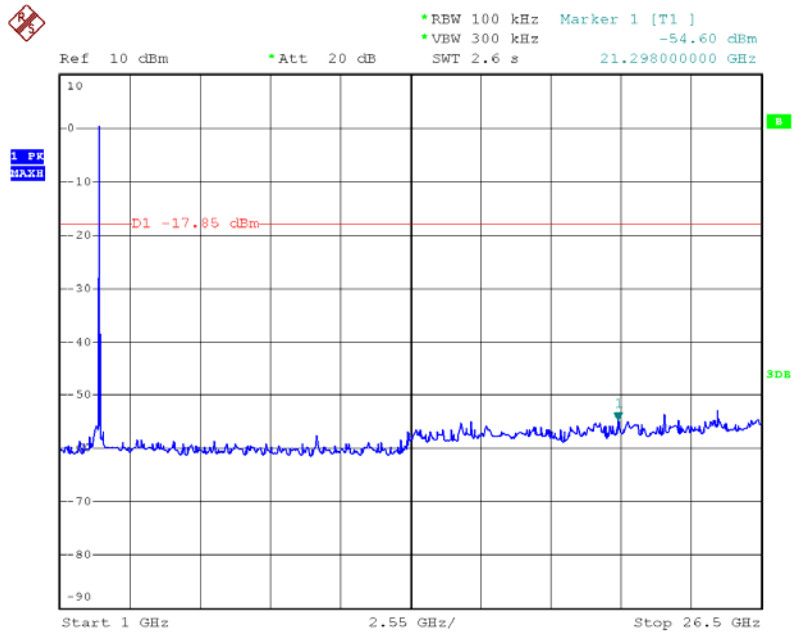

Date: 18.AUG.2012 15:13:06

Bellow 1 GHz

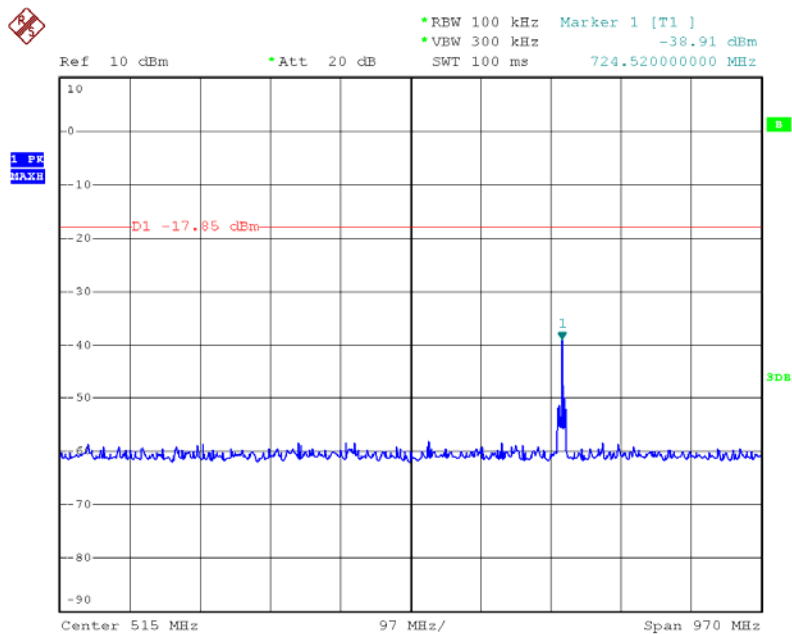

Date: 18.AUG.2012 15:12:50

802.11g Mode TX CH 01 2412MHz

Above 1 GHz

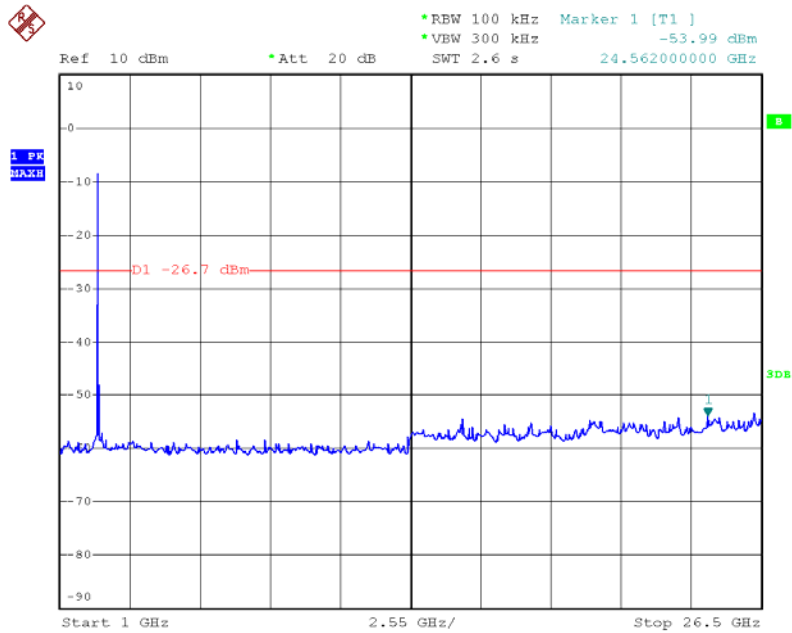

Date: 18.AUG.2012 15:17:17

Bellow 1 GHz

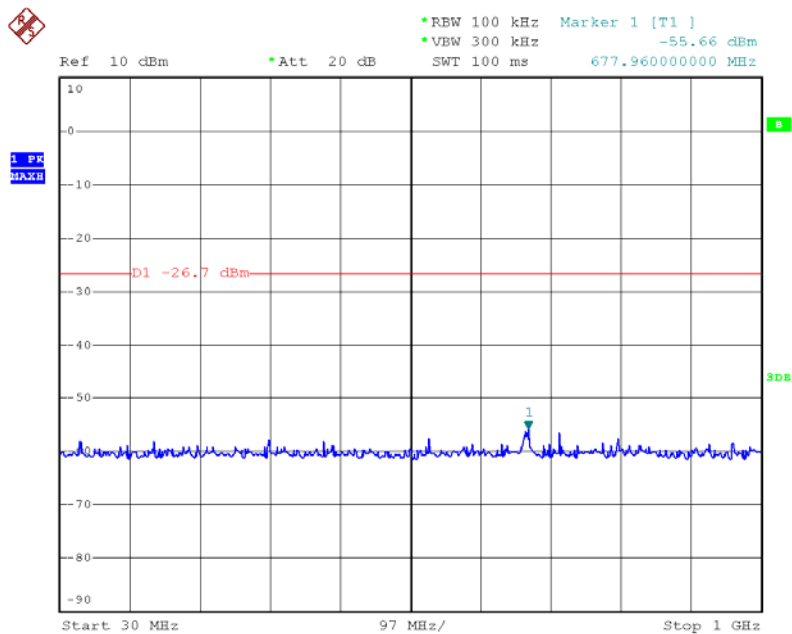

Date: 18.AUG.2012 15:17:01

802.11g Mode

TX CH 06 2437MHz

Above 1 GHz

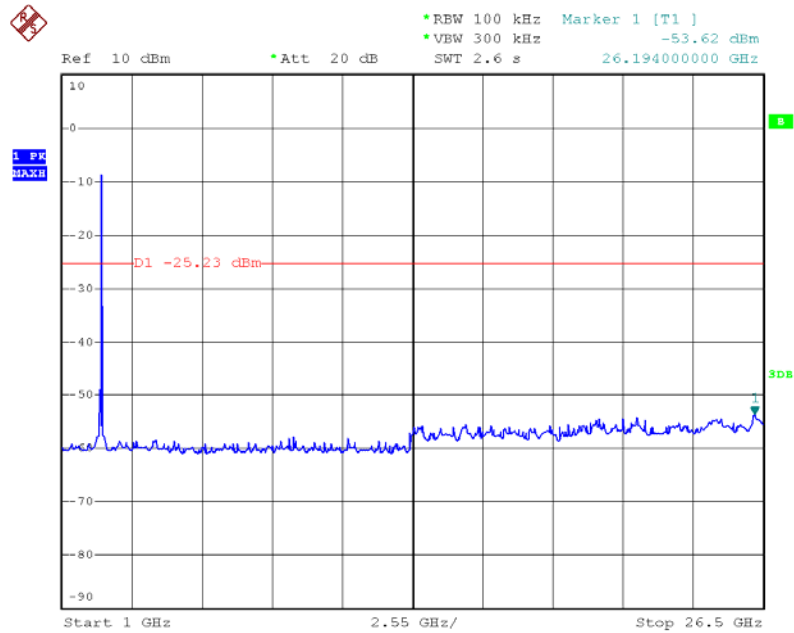

Date: 18.AUG.2012 15:17:50

Bellow 1 GHz

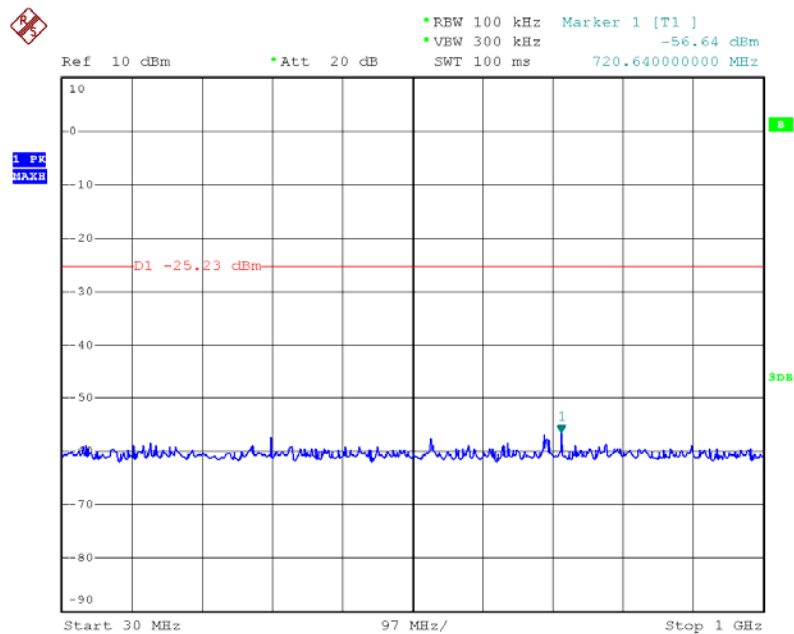

Date: 18.AUG.2012 15:18:09

802.11g Mode

TX CH 11 2462MHz

Above 1 GHz

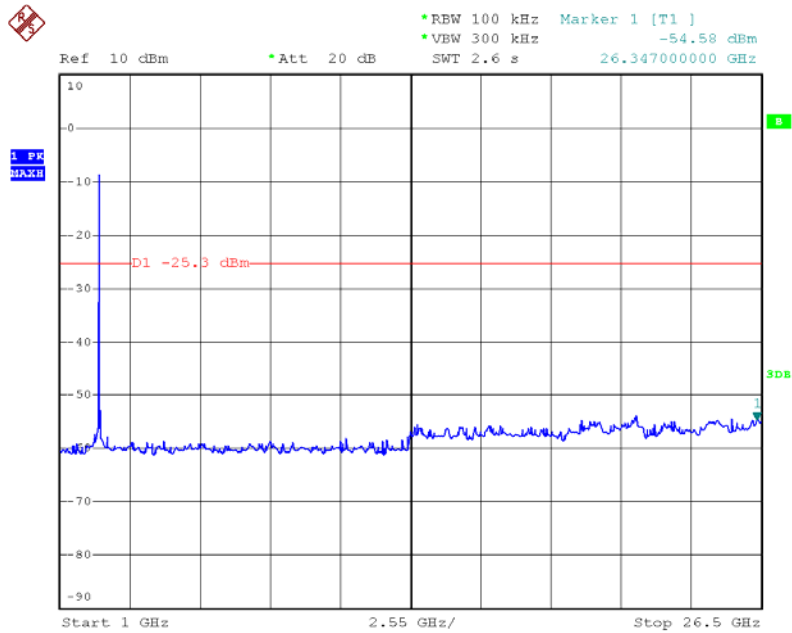

Date: 18.AUG.2012 15:19:13

Bellow 1 GHz

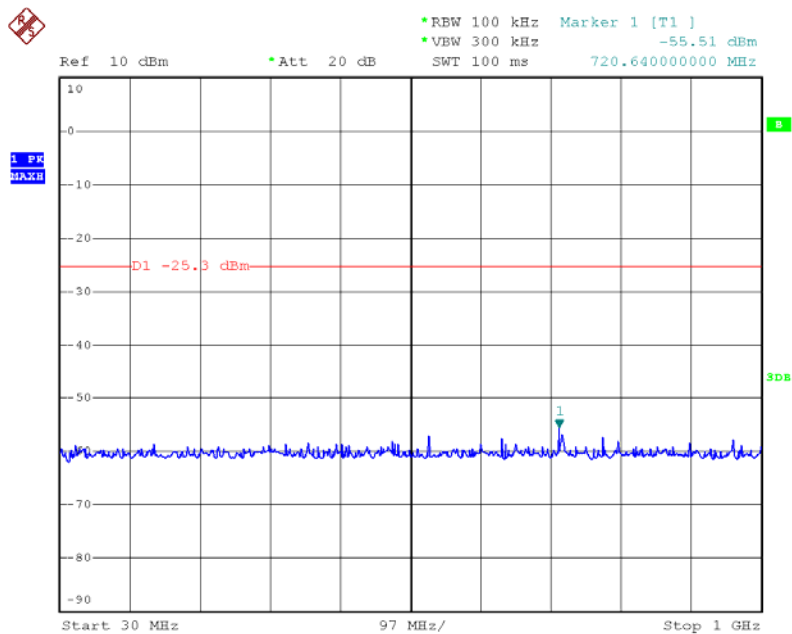

Date: 18.AUG.2012 15:18:52

802.11n (HT20) Mode TX CH 01 2412MHz

Above 1 GHz

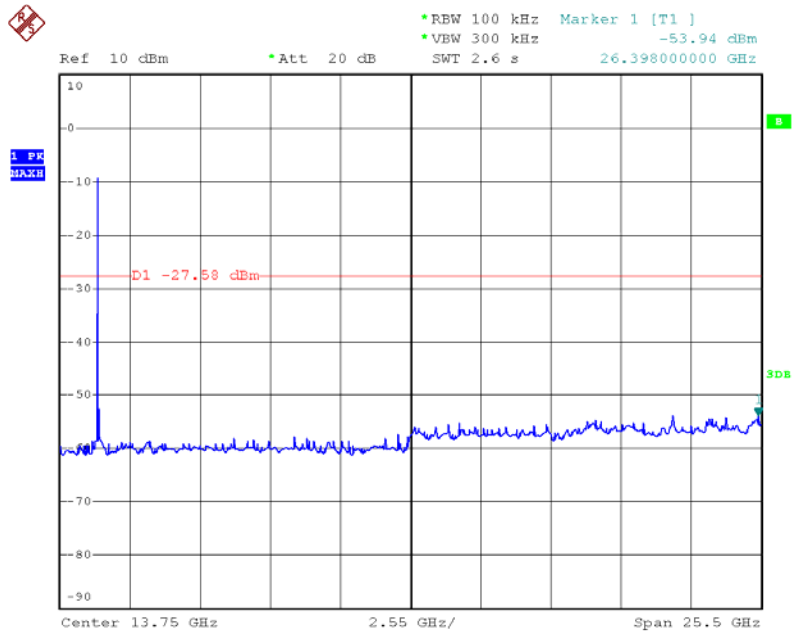

Date: 18.AUG.2012 15:20:24

Bellow 1 GHz

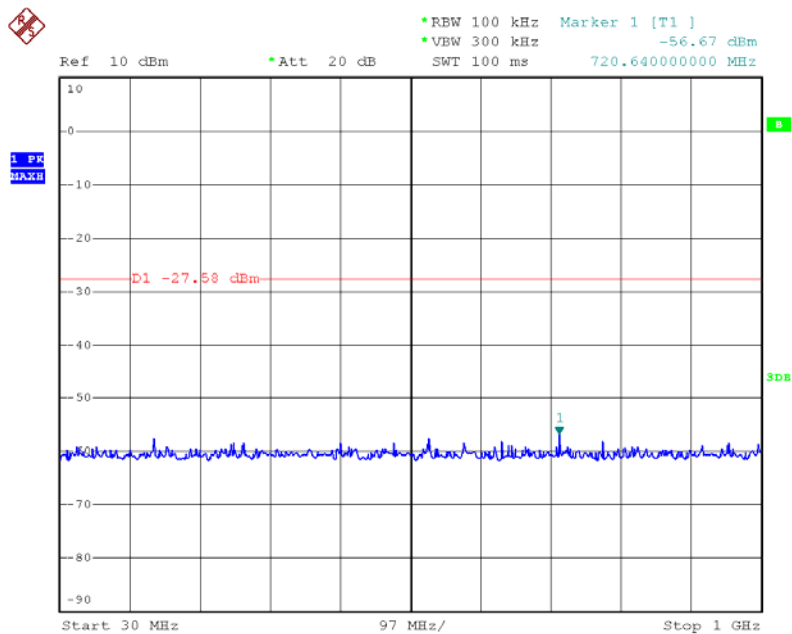

Date: 18.AUG.2012 15:21:06

802.11n (HT20) Mode

TX CH 06 2437MHz

Above 1 GHz

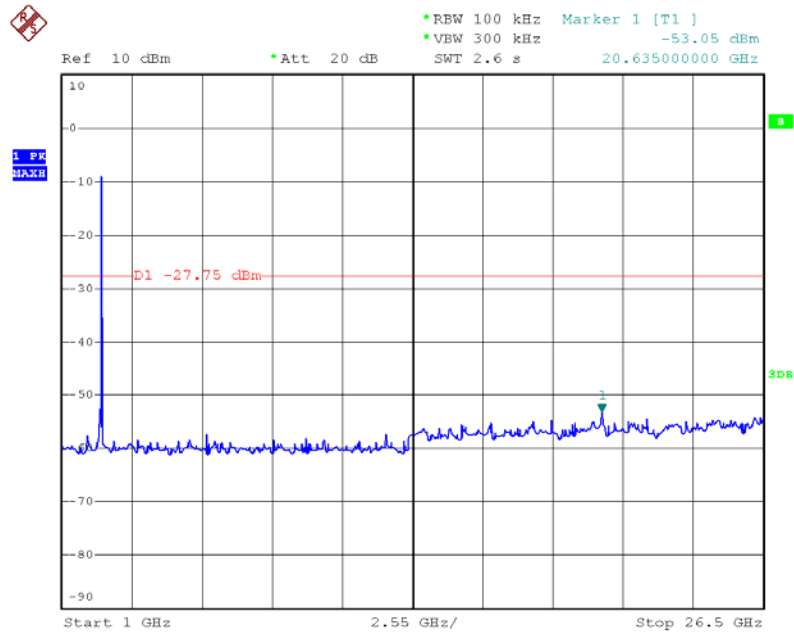

Date: 18.AUG.2012 15:22:05

Bellow 1 GHz

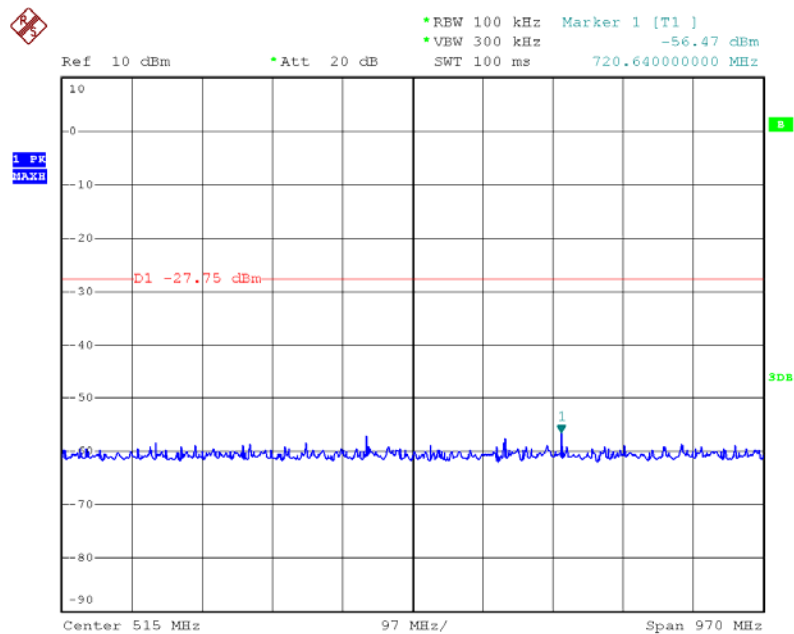

Date: 18.AUG.2012 15:21:44

802.11n(HT20) Mode

TX CH 11 2462MHz

Above 1 GHz

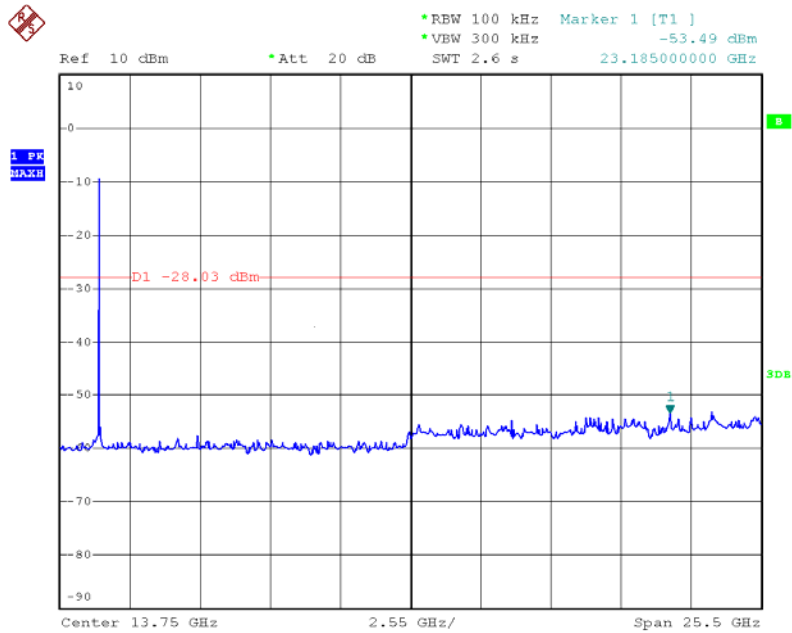

Date: 18.AUG.2012 15:22:50

Bellow 1 GHz

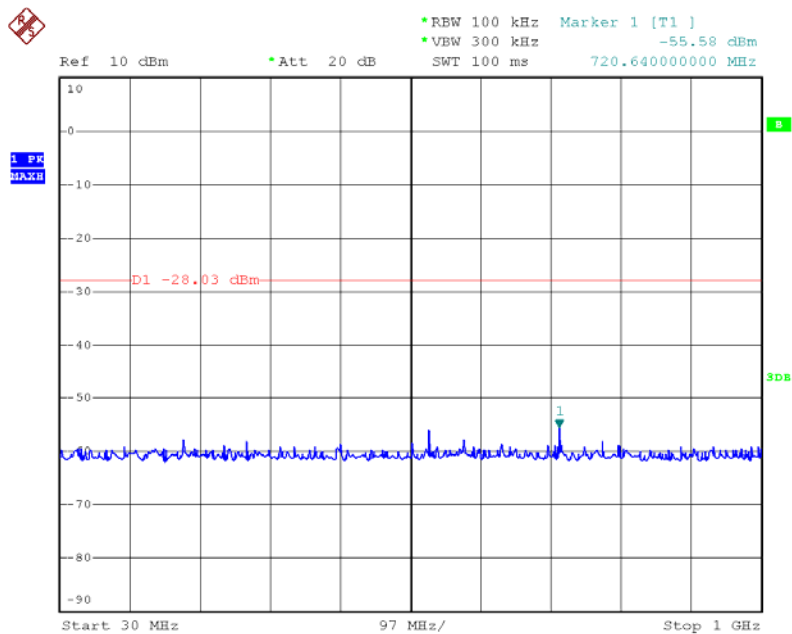

Date: 18.AUG.2012 15:23:20

802.11n (HT40) Mode TX CH 01 2422MHz

Above 1 GHz

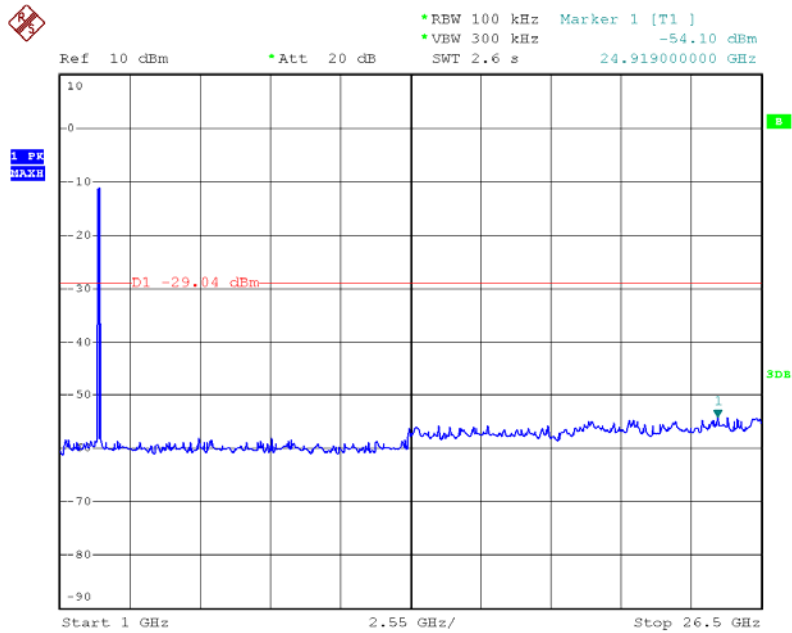

Date: 18.AUG.2012 15:26:31

Bellow 1 GHz

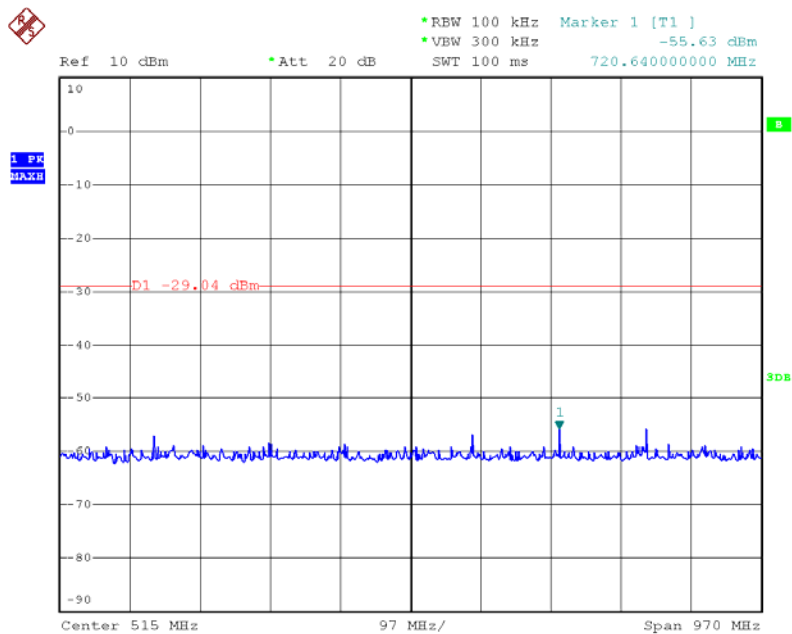

Date: 18.AUG.2012 15:25:48

802.11n (HT40) Mode TX CH 06 2437MHz

Above 1 GHz

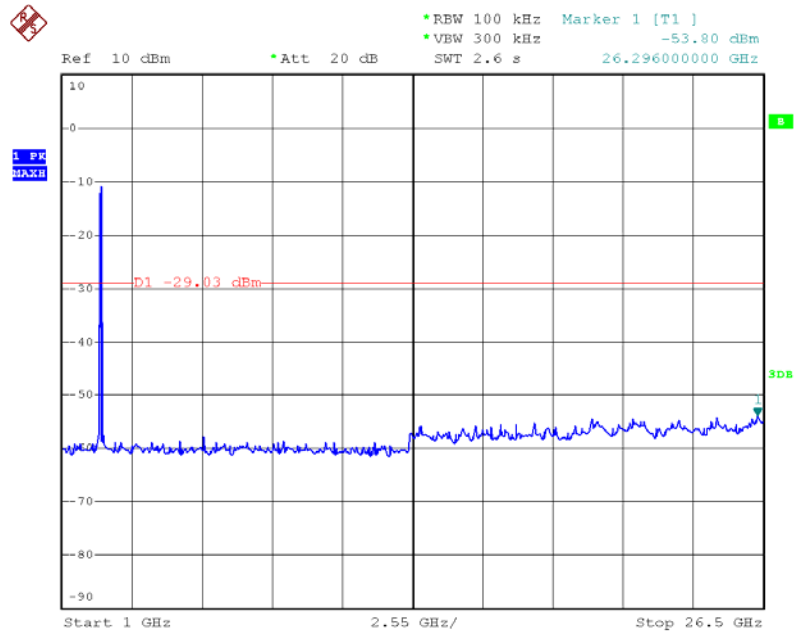

Date: 18.AUG.2012 15:27:04

Bellow 1 GHz

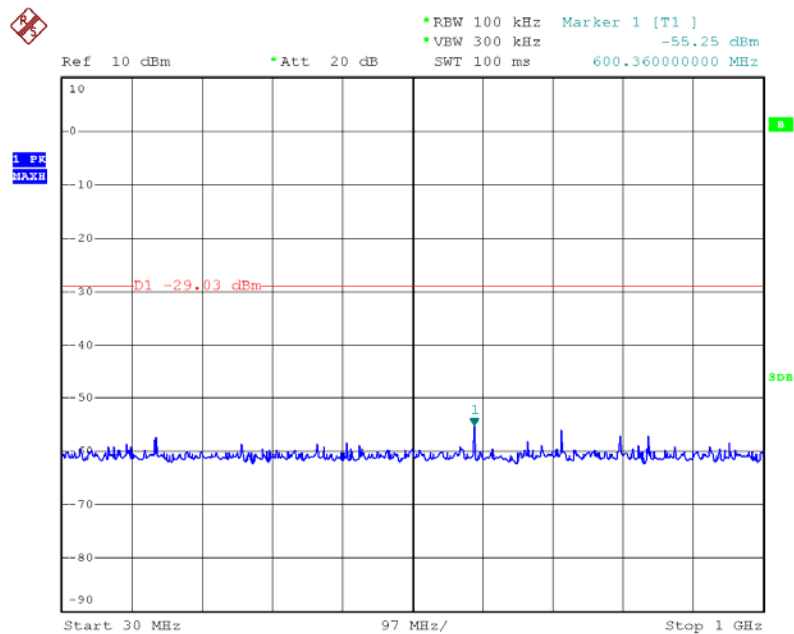

Date: 18.AUG.2012 15:27:19

802.11n (HT40) Mode

TX CH 11 2452MHz

Above 1 GHz

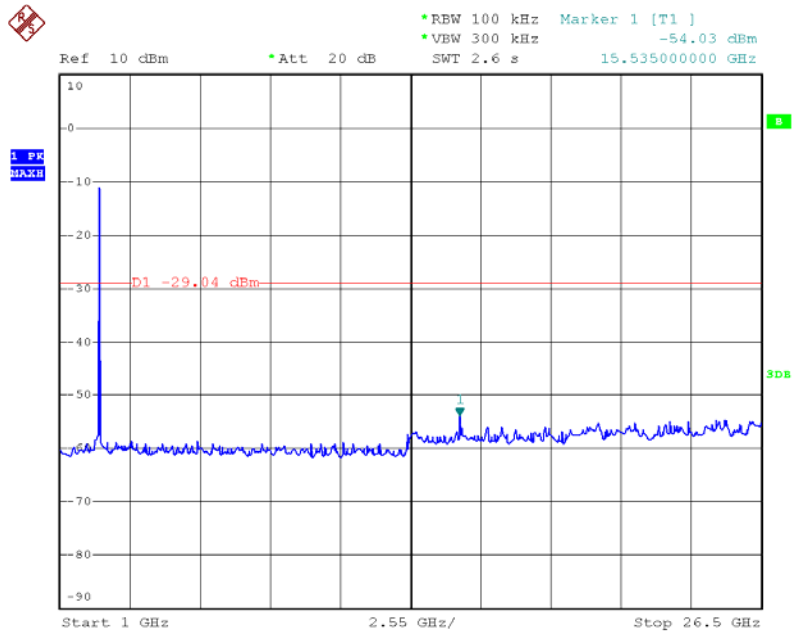

Date: 18.AUG.2012 15:28:05

Bellow 1 GHz

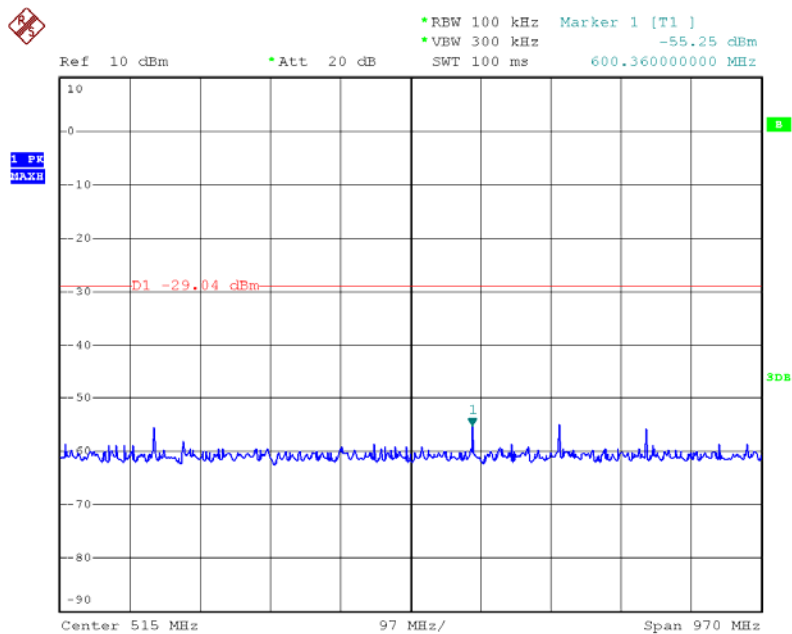

Date: 18.AUG.2012 15:27:51

10. Antenna Requirement

10.1 Standard Requirement

11.1.1 Standard

FCC Part 15.203

11.1.2 Requirement

An intentional radiator shall be designed to ensure that no antenna other than that furnished by the responsible party shall be used with the device. The use of a permanently attached antenna or of an antenna that uses a unique coupling to the intentional radiator shall be considered sufficient to comply with the provisions of this Section. The manufacturer may design the unit so that a broken antenna can be replaced by the user, but the use of a standard antenna jack or electrical connector is prohibited.

10.2 Antenna Connected Construction

The directional gains of the antenna used for transmitting is 1 Bi, and the antenna de-signed with permanent attachment and no consideration of replacement. Please see the EUT photo for details.

10.2 Result

The EUT antenna is a Printed Antenna. It complies with the standard requirement.