

B

7

6

5

4

3

2

1

PROPRIETARY NOTICE

THIS DOCUMENT AND THE INFORMATION DISCLOSED HEREIN ARE PROPRIETARY DATA OF ACSS, LLC. NEITHER THIS DOCUMENT NOR THE INFORMATION CONTAINED HEREIN SHALL BE REPRODUCED, USED, OR DISCLOSED TO OTHERS WITHOUT THE WRITTEN AUTHORIZATION OF ACSS, LLC.

NOTICE

FREEDOM OF INFORMATION ACT (5 USC 552) AND DISCLOSURE OF CONFIDENTIAL INFORMATION GENERALLY (18 USC 1905). THIS DOCUMENT IS BEING FURNISHED IN CONFIDENCE BY ACSS, LLC. THE INFORMATION DISCLOSED HEREIN FALLS WITHIN EXEMPTION (b) (4) OF 5 USC 552 AND THE PROHIBITIONS OF 18 USC 1905.

CHG. NO.	REV.	REVISION DESCRIPTION	DATE
008430	-	INITIAL RELEASE	04-02-05
008580	A	UPDATE SH 2, 7 AND 11. PL AFFECTED.	05-05-05
008672	B	UPDATE SH 1, 2, 3, 6, 35 AND 47. PL AFFECTED.	08-29-05
008958	C	UPDATE SH 35, 47 AND 63. PL AFFECTED.	09-14-05
009036	D	UPDATE SH 1 AND 94. PL AFFECTED.	10-18-05

TABLE 1 BUSWIRE DATA

CCA SIDE	COND NO.	ITEM NO.	FROM CIRCUIT POINT	TO CIRCUIT POINT
TOP	601	704	U30-32 (PAD)	U30-30 (PAD)

NOTES:

1. ASSEMBLE PER ITEM 701 (M7012784).

2. THIS ASSEMBLY INCLUDES COMPONENTS WHICH ARE SUBJECT TO DAMAGE BY ELECTROSTATIC CHARGES; THEREFORE, ALL COMPONENTS SHALL BE HANDLED IN ACCORDANCE WITH GUIDELINES FOR ELECTROSTATIC DISCHARGE CONTROL.

3. COMPONENT LEAD PROTRUSION SHALL BE .060 MAXIMUM. BARE COPPER PERMISSIBLE ON COMPONENT LEADS AT TRIMMED SURFACES.

4. MAXIMUM COMPONENT HEIGHT ON TOP SIDE SHALL BE .550. MAXIMUM COMPONENT HEIGHT ON BOTTOM SIDE SHALL BE .070.

5. SQUARE PADS, WHEN PRESENT, ON PRINTING WIRING BOARD INDICATE PIN 1.

CONFORMAL COAT CCA PER ITEM 702. EXCEPT AREAS NOTED.

SHADED COMPONENTS ARE NOT INSTALLED.

SECURE C178 AND C180 TO PWB, ITEM 1, USING ITEM 703.

INSTALL BUSWIRES PER TABLE 1, LEFT OR RIGHT, TOP OR BOTTOM, AS VIEWED FROM INDICATED SIDE.

REVISION STATUS OF PARTS LIST SHALL BE THE SAME AS THE BASIC DRAWING NUMBER. SEE SEPARATE PARTS LIST.

UNLESS OTHERWISE SPECIFIED, DIMENSIONS ARE IN INCHES; TOLERANCES: ANGLES ± - 2 PL DEC ± - 3 PL DEC ± -		THIRD ANGLE PROJECTION	OPERATIONAL NOTE
INTERPRET DIMENSIONS AND TOLERANCES PER ASME Y14.5M-1994		FOR REFERENCE	 CIRCUIT CARD ASSEMBLY - PROCESSOR
		ORIGINAL C. D.	
		PRODUCT LINE NO.	
		AWIPS ANALYSIS EB	
		REF. DWG. REF. SPEC.	
9003000-55	9003000-55001	STOCK CODE	DRAWING NO.
NEXT ASSY	END ITEM	E1WYD3	9003020-0031D
APPLICATION		SCALE NONE	SHEET 1 OF 09

9003020-0031

B

7

6

5

4

3

2

1

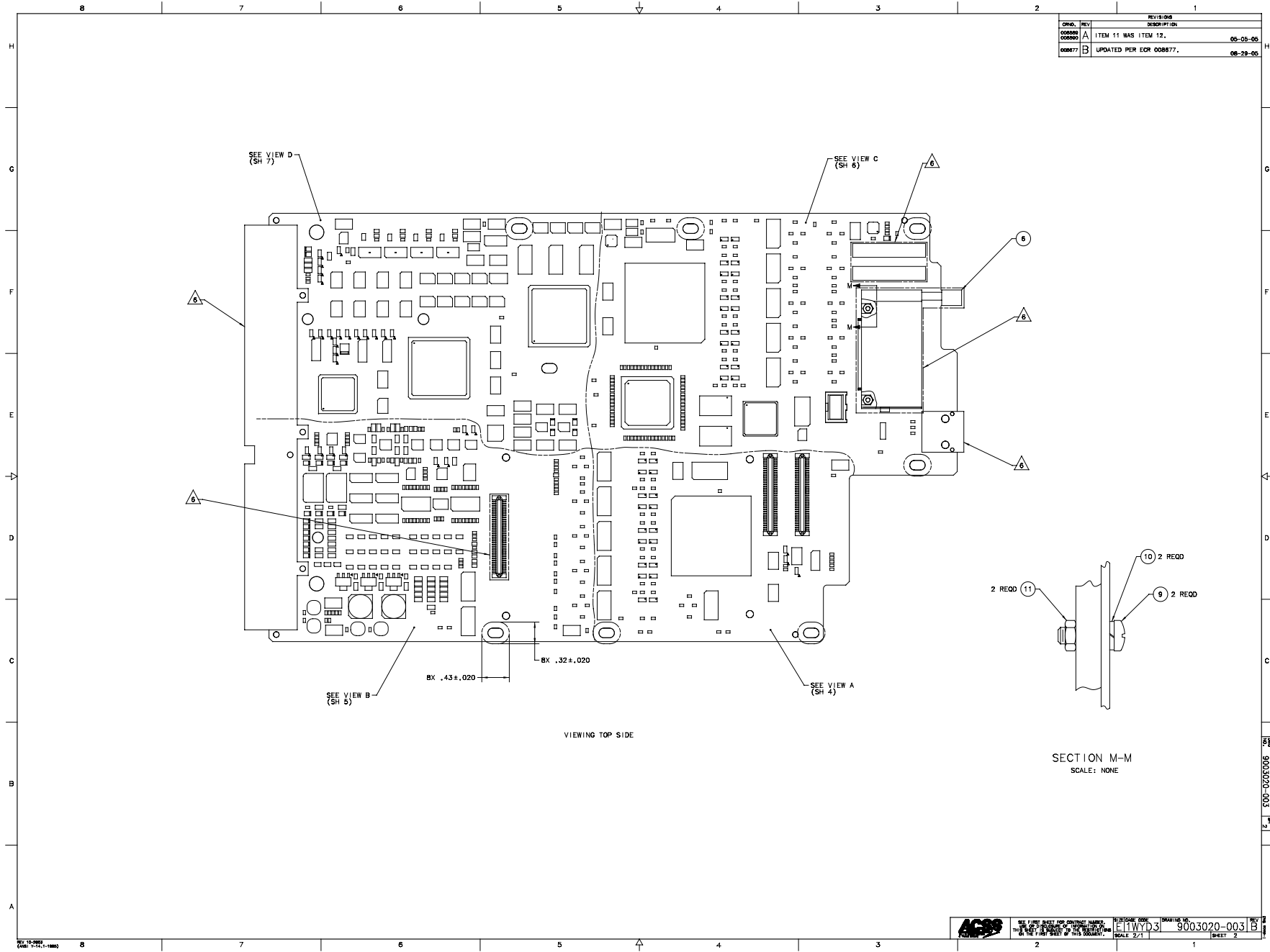

NO.	REV.	DESCRIPTION	DATE
00866	A	ITEM 11 WAS ITEM 12.	05-05-05
00867	B	UPDATED PER ECR 008677.	06-29-05

SECTION M-M
SCALE: NONE

VIEWING TOP SIDE

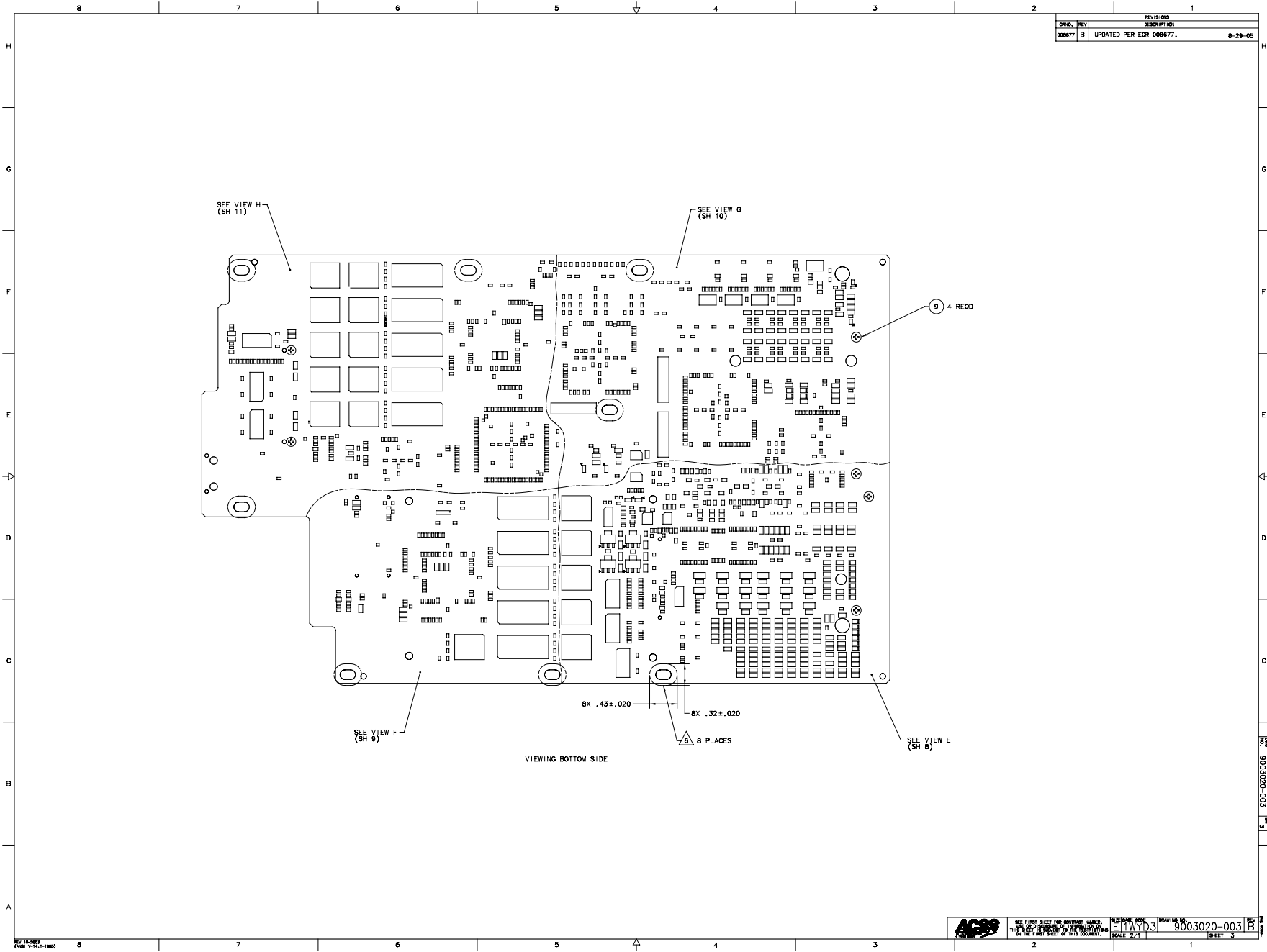

NO.	REV.	DESCRIPTION	DATE
008677	B	UPDATED PER ECR 008677.	8-29-05

 SEE FIRST SHEET FOR CONTRACT NUMBER
 THE FIRST SHEET OF THIS DRAWING IS THE TITLE SHEET
 THIS SHEET IS ONE OF THE RESULTS OF THE DESIGN PROCESS
 SCALE 2/1
 DRAWING NO. 9003020-003
 SHEET 3

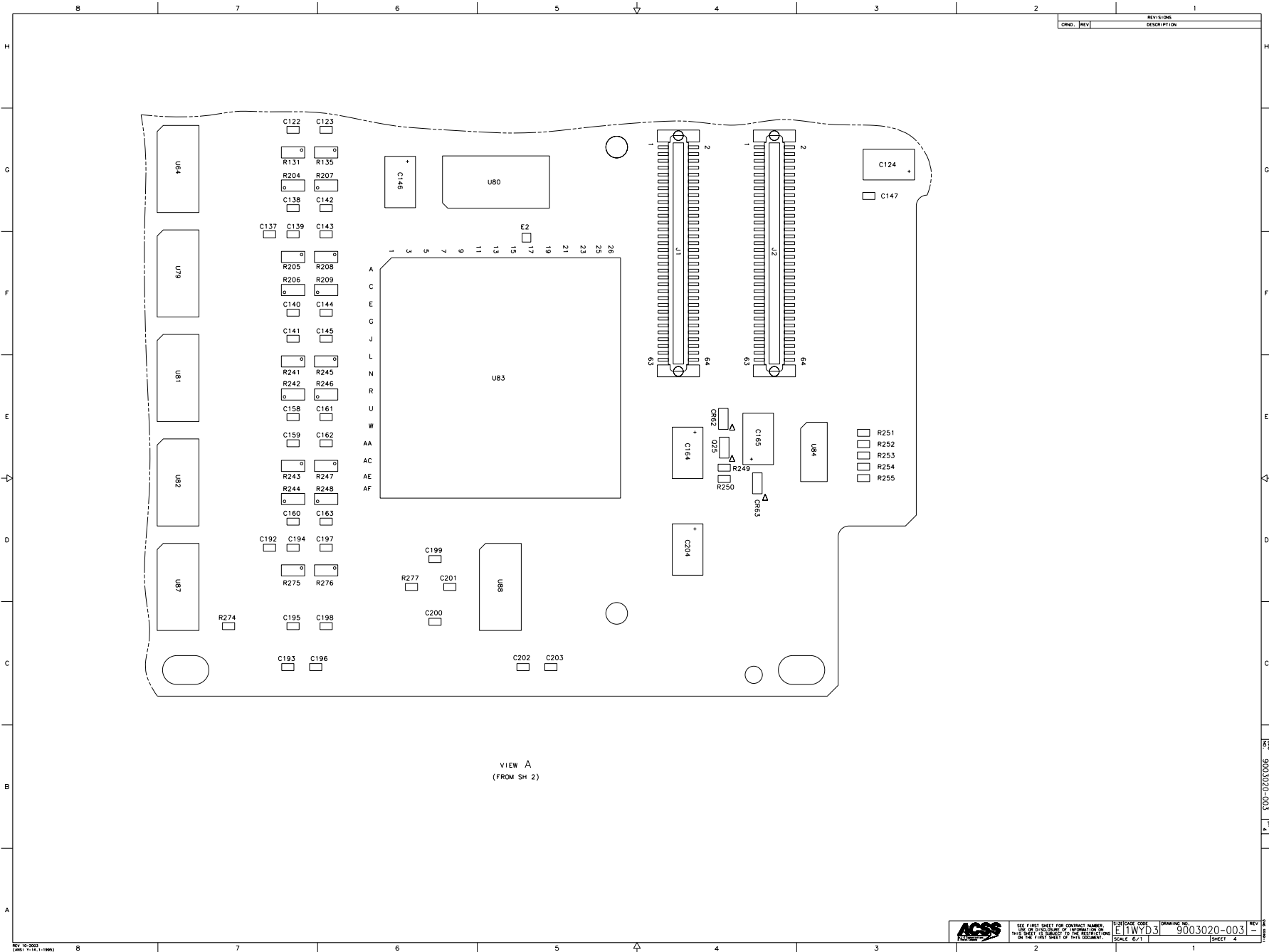

REVISIONS	
CRNO.	DESCRIPTION

A
C
E
G
J
L
N
R
U
W
AA
AC
AE
AF

VIEW A
(FROM SH 2)

9003020-003

	<small>SEE FIRST SHEET FOR DRAWING NUMBER</small> <small>NUMBER OF REVISIONS TO BE IMPLEMENTED</small> <small>ON THE FIRST SHEET OF THIS DOCUMENT</small>	<small>PROJECT CODE</small> E11WYD3	<small>DRAWING NO.</small> 9003020-003	<small>REV.</small> 4
	<small>SCALE: 6/21</small>	<small>SHEET</small> 4	<small>DATE</small> 11/11/2003	<small>BY</small>

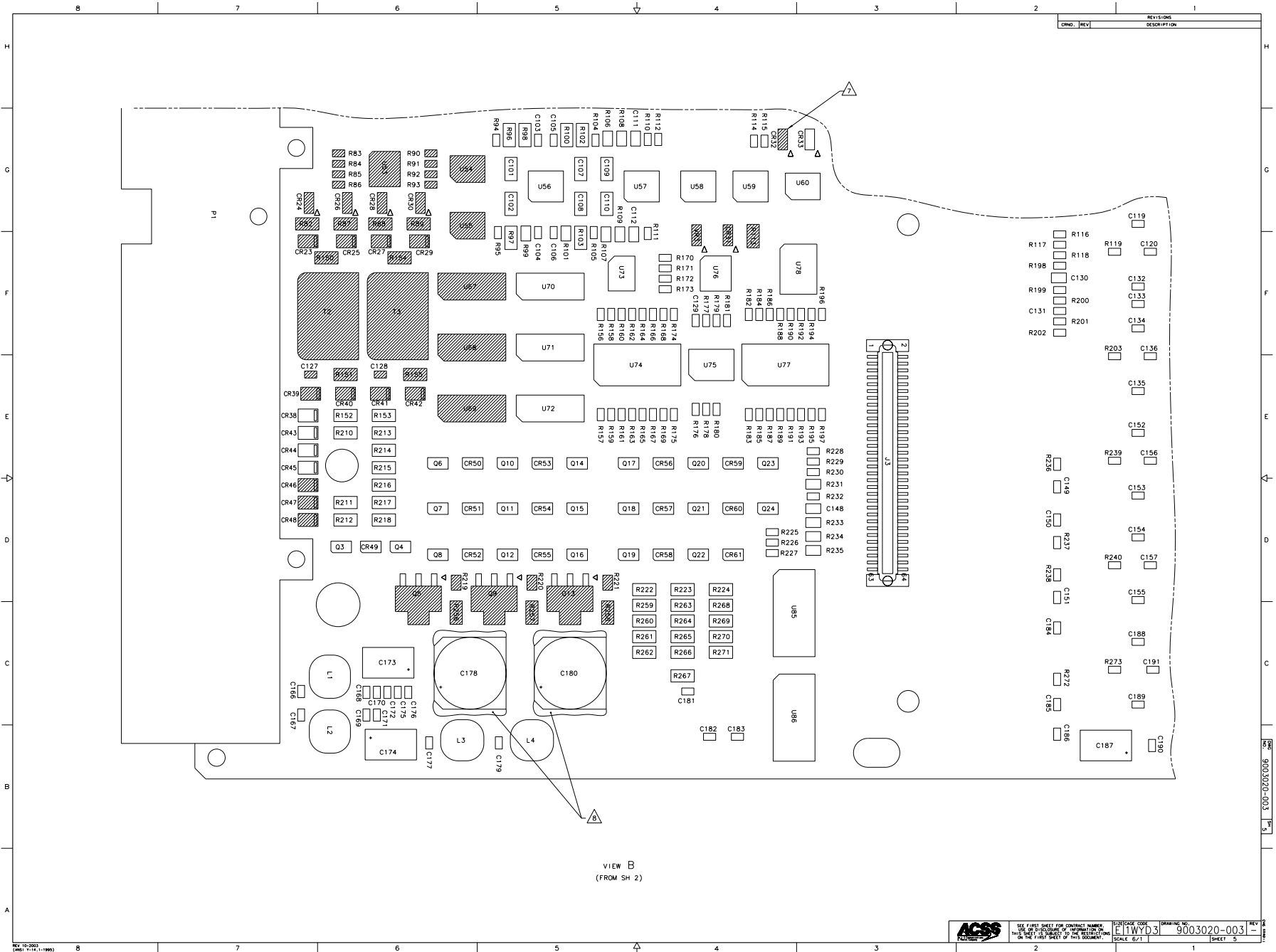

VIEW B
(FROM SH 2)

NO.	REV.	DESCRIPTION
000677	B	SHADED R15.

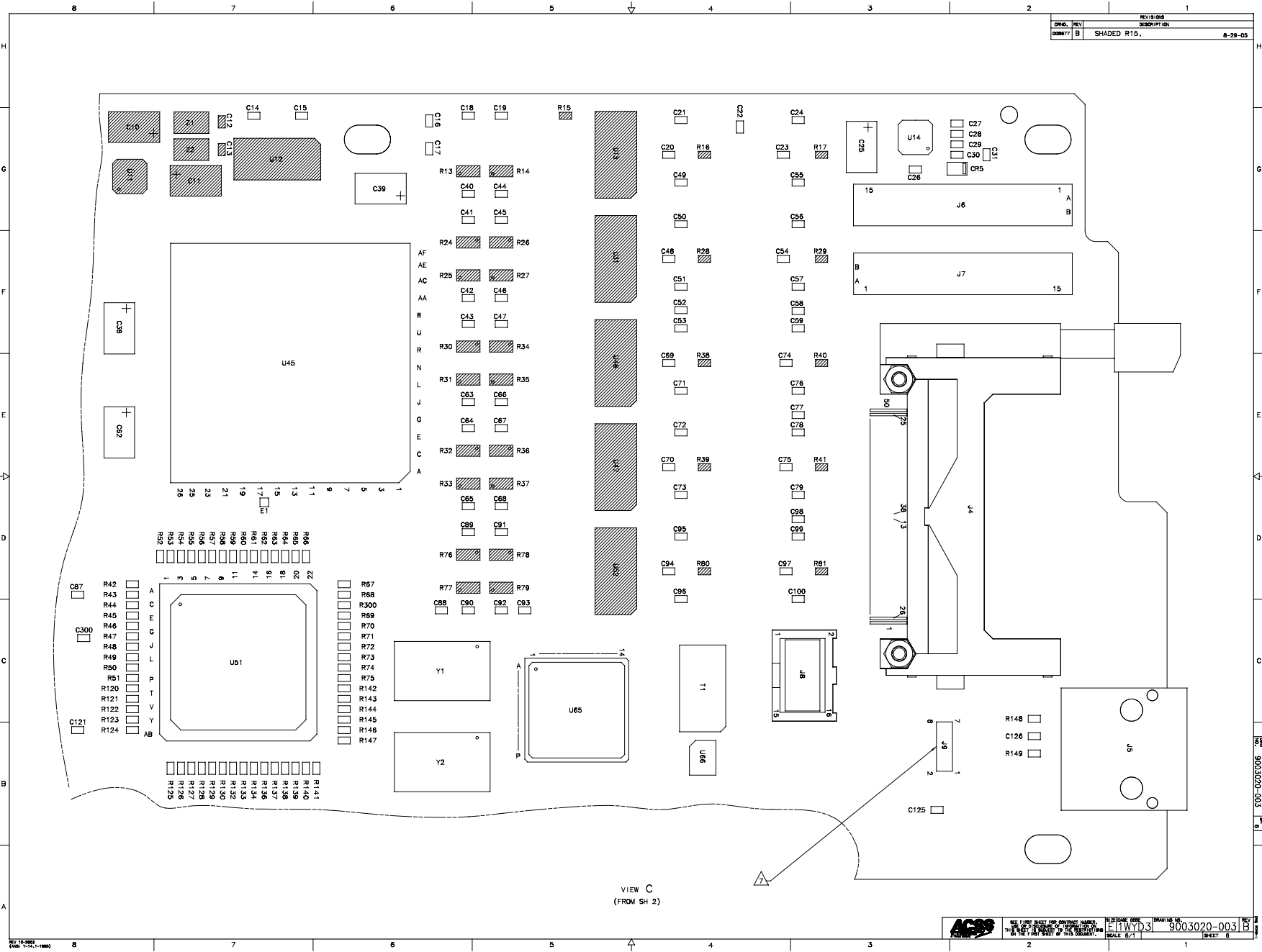

VIEW C
(FROM SH 2)

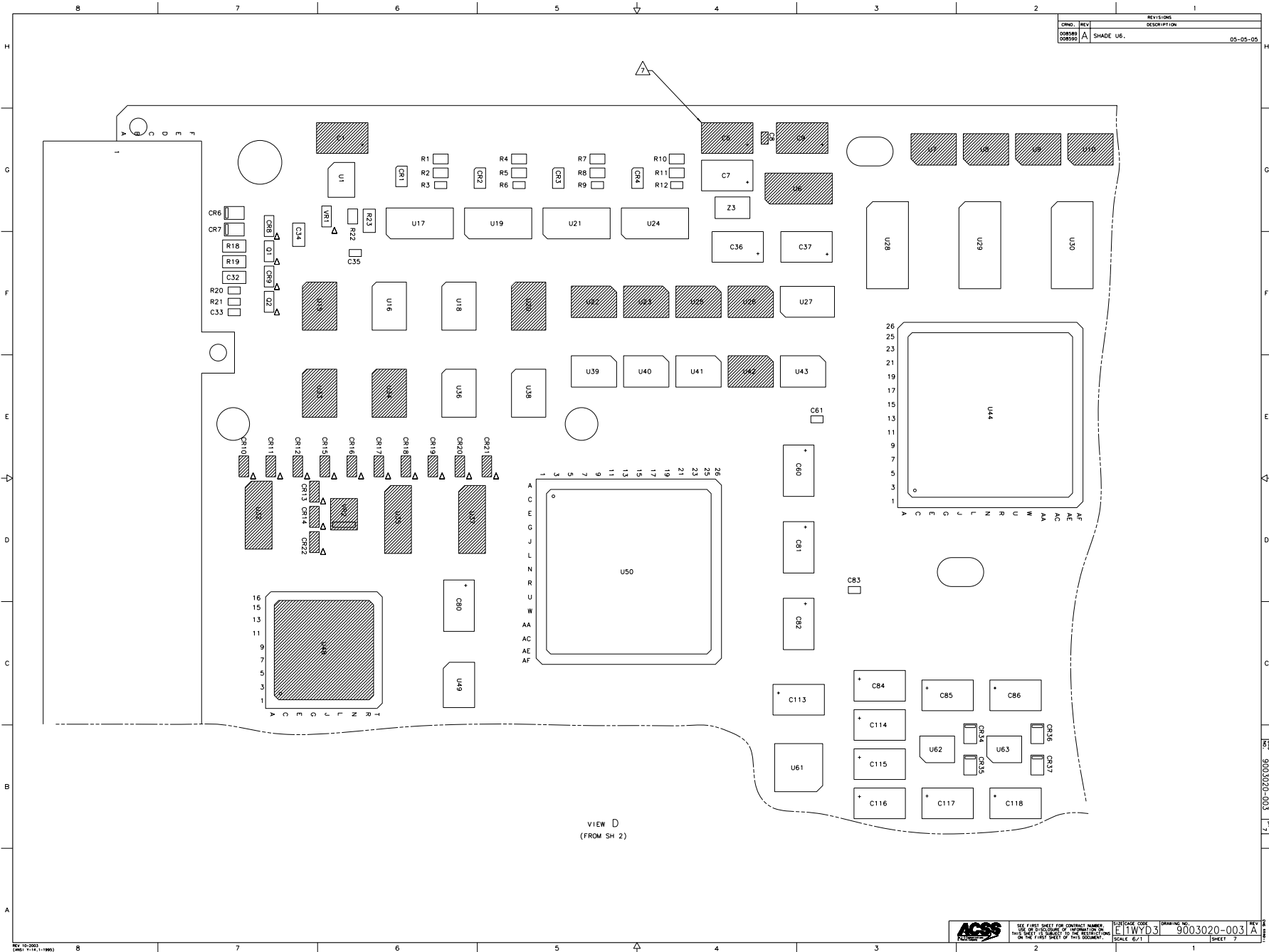

REVISIONS		DATE
NO.	REV.	DESCRIPTION
1	A	SHADE U6.

VIEW D
(FROM SH 2)

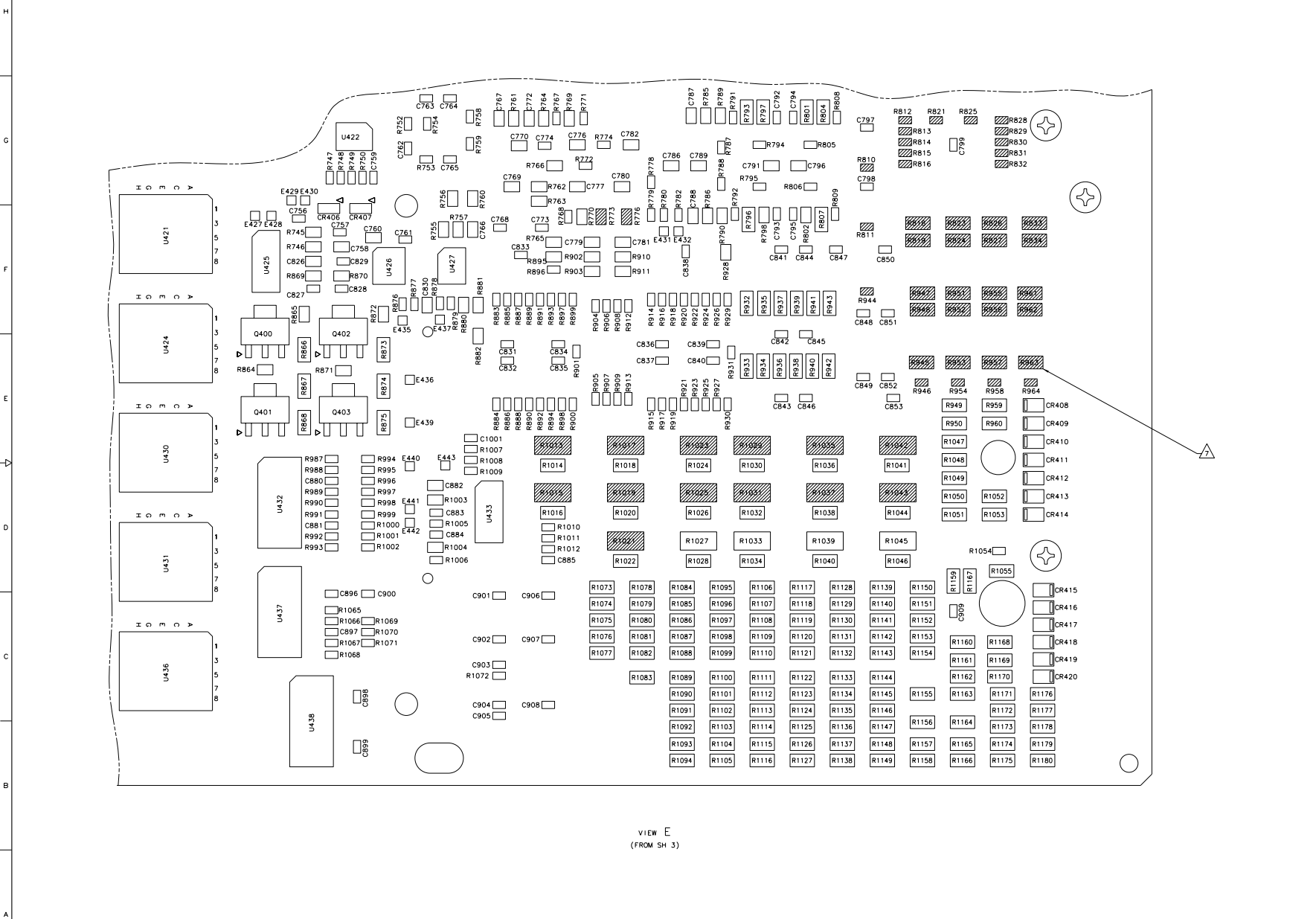

VIEW E
(FROM SH 3)

NO.	REV.	REVISIONS DESCRIPTION
00000		
00000	A	UNSHADE R701.

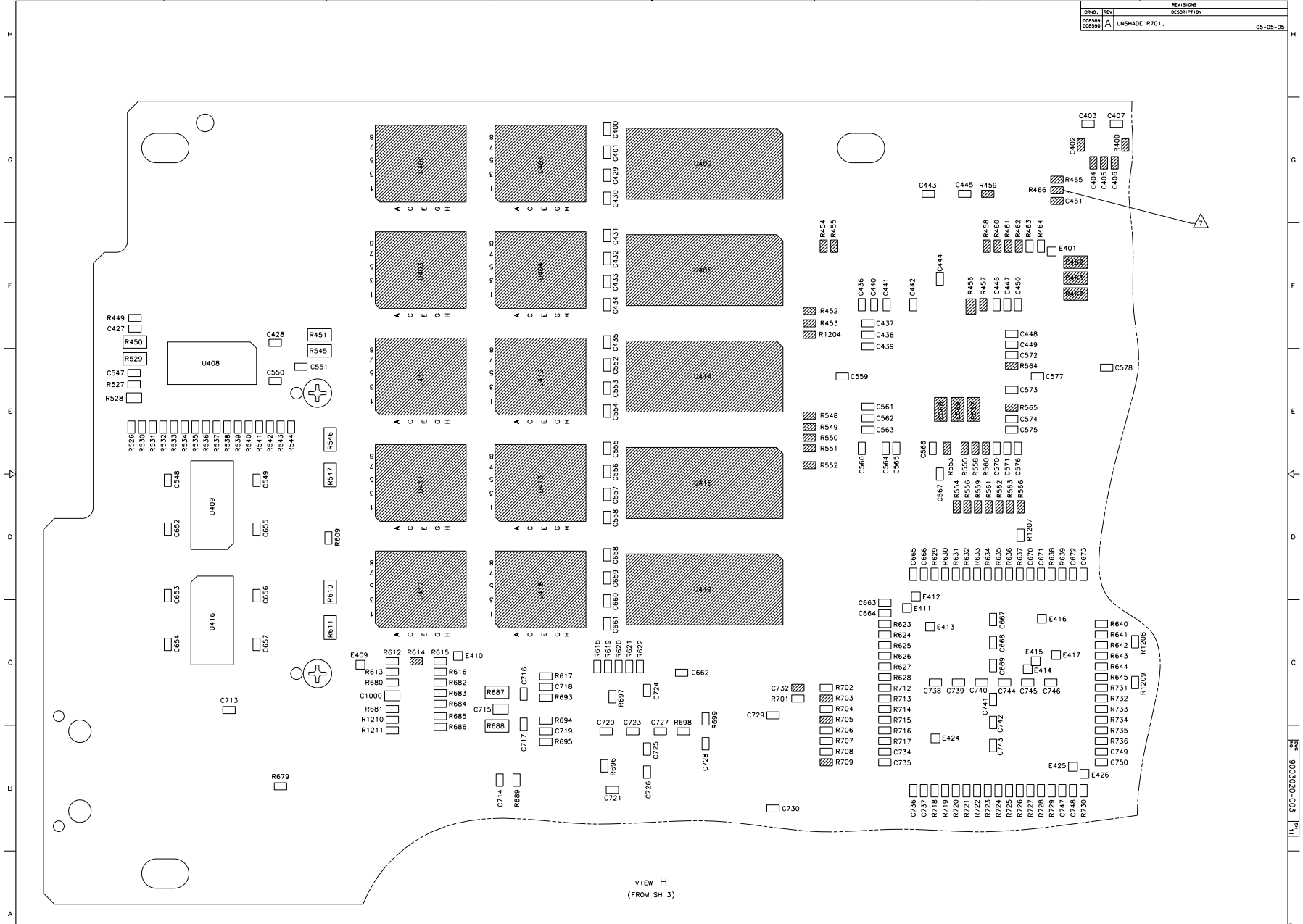

VIEW H
(FROM SH 3)

 SITE PLAN SHEET FOR PROJECT NUMBER
 9003020-003
 DRAWING NO. 9003020-003
 SCALE 6/21 SHEET 11

REVISIONS	
REV	DESCRIPTION

THIS PAGE INTENTIONALLY LEFT BLANK

D

D

C

C

B

B

A

A

COMPUTER GENERATED

ACSS	<small>SEE FIRST SHEET FOR CONTRACT NUMBER. USE OR DISCLOSURE OF INFORMATION ON THIS SHEET IS SUBJECT TO THE RESTRICTIONS ON THE FIRST SHEET OF THIS DOCUMENT.</small>	SIZE	CAGE CODE	DWG. NO.	REV
		D	1WYD3	9003020-003	-

REVISIONS	
REV	DESCRIPTION

THIS PAGE INTENTIONALLY LEFT BLANK

D

D

C

C

B

B

A

A

COMPUTER GENERATED

ACSS	<small>SEE FIRST SHEET FOR CONTRACT NUMBER. USE OR DISCLOSURE OF INFORMATION ON THIS SHEET IS SUBJECT TO THE RESTRICTIONS ON THE FIRST SHEET OF THIS DOCUMENT.</small>	SIZE	CAGE CODE	DWG. NO.	REV
		D	1WYD3	9003020-003	-

REVISIONS	
REV	DESCRIPTION

THIS PAGE INTENTIONALLY LEFT BLANK

D

D

C

C

B

B

A

A

COMPUTER GENERATED

ACSS	<small>SEE FIRST SHEET FOR CONTRACT NUMBER. USE OR DISCLOSURE OF INFORMATION ON THIS SHEET IS SUBJECT TO THE RESTRICTIONS ON THE FIRST SHEET OF THIS DOCUMENT.</small>	SIZE	CAGE CODE	DWG. NO.	REV
		D	1WYD3	9003020-003	-
SCALE: NONE		SHEET 14			

DWG. NO.	9003020-003	SH.	15	REV.	-
REVISIONS					
REV.	DESCRIPTION				

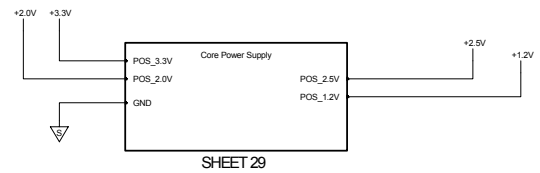
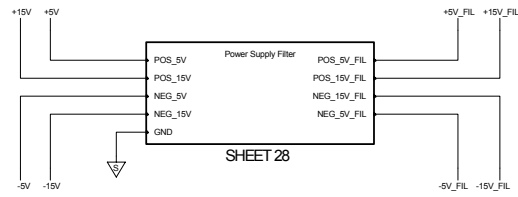

POWER SUPPLY & FILTERS - TOP VIEW
 COMMON PROCESSOR ASSEMBLY - TOP
 SHEET NO. 1 OF 13

COMPUTER GENERATED

ACSS	SEE FIRST SHEET FOR CONTRACT NUMBER. USE OR DISCLOSURE OF INFORMATION ON THIS SHEET IS SUBJECT TO THE RESTRICTIONS ON THE FIRST SHEET OF THIS DOCUMENT.	SIZE	CAGE CODE	DWG. NO.	REV.
		D	1WYD3	9003020-003	-
SCALE: NONE		SHEET 15			

REVISIONS	
REV	DESCRIPTION

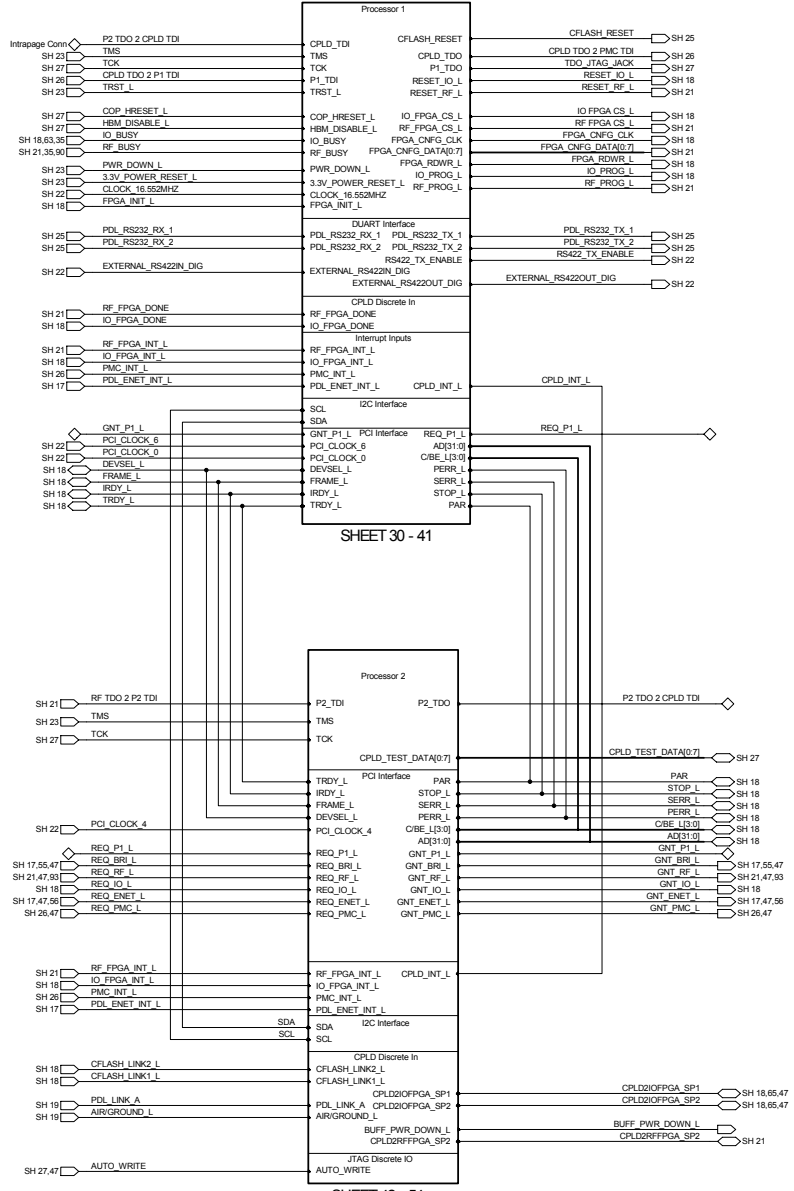

PROCESSOR 1 AND 2 - TOP VIEW
 COMMON PROCESSOR ASSEMBLY - TOP
 SHEET NO. 2 OF 13

COMPUTER GENERATED

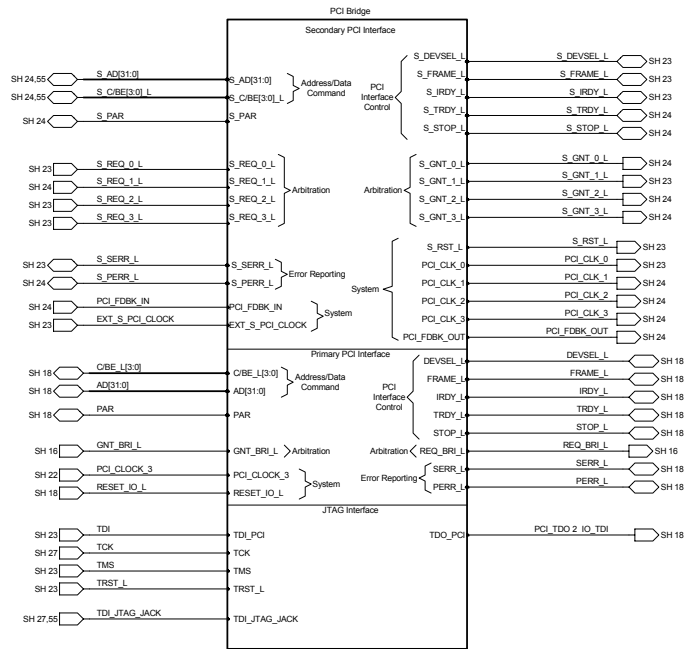

SHEET 55

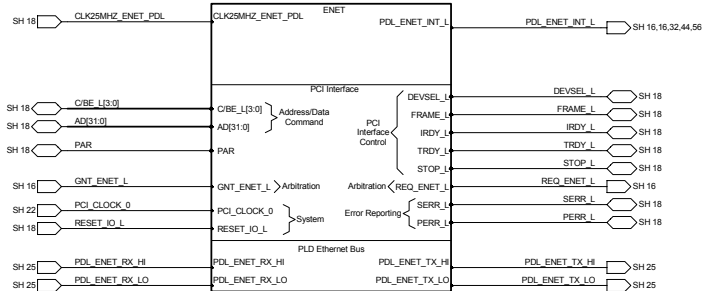

SHEET 56 - 57

PCI BRIDGE & ETHERNET - TOP VIEW
COMMON PROCESSOR ASSEMBLY - TOP
SHEET NO. 3 OF 13

COMPUTER GENERATED

ACSS

SEE FIRST SHEET FOR CONTRACT NUMBER. USE OR DISCLOSURE OF INFORMATION ON THIS SHEET IS SUBJECT TO THE RESTRICTIONS ON THE FIRST SHEET OF THIS DOCUMENT.

SIZE: D 1WYD3

DWG NO. 9003020-003

REV -

SCALE: NONE

SHEET 17

REVISIONS	
REV	DESCRIPTION

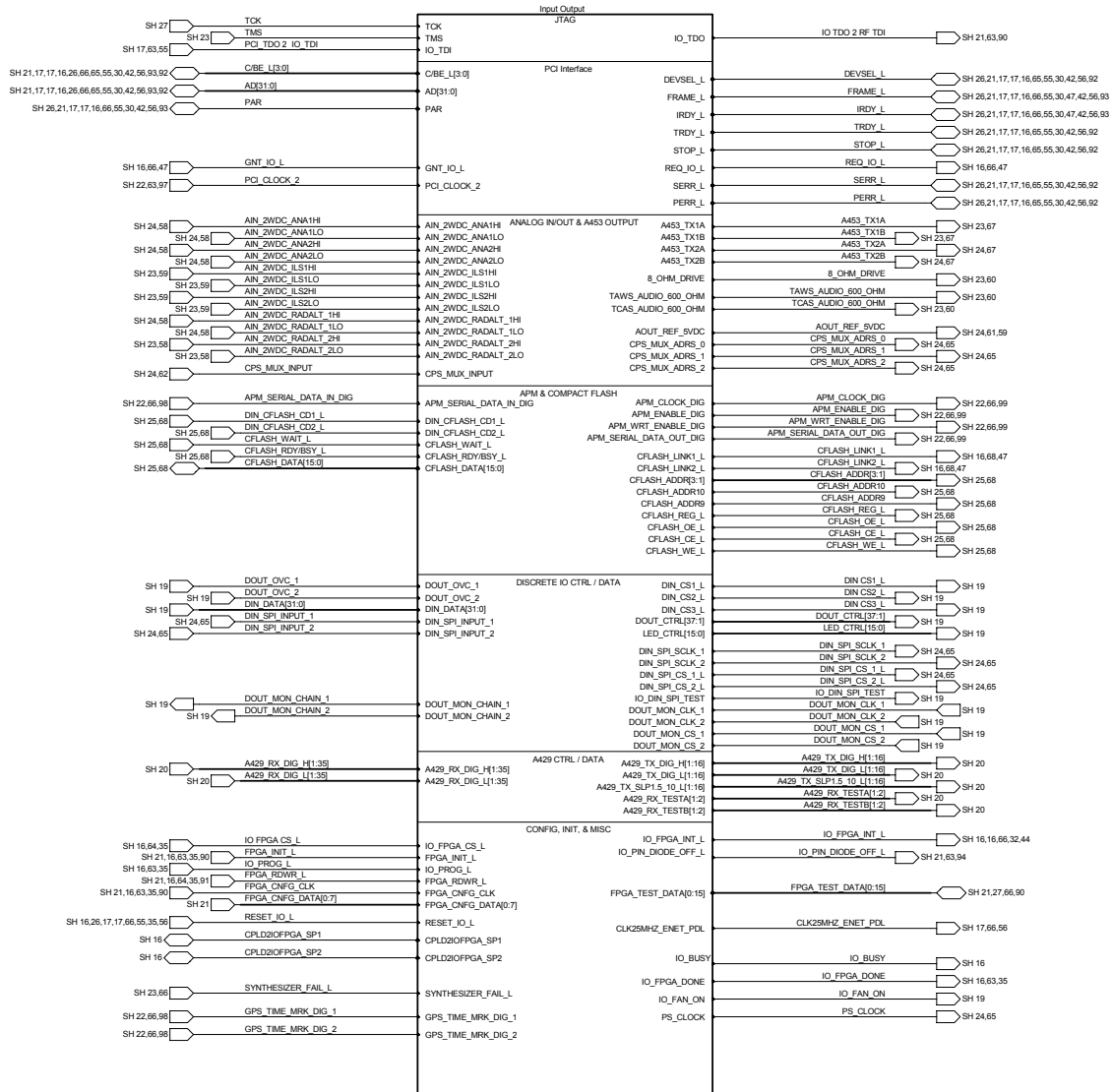

SHEET 58 - 68

ANALOG IN, APM, COMPACT FLASH
DIGITAL AUDIO & A453 - TOP VIEW
COMMON PROCESSOR ASSEMBLY - TOP
SHEET NO. 4 OF 13

COMPUTER GENERATED

ACSS	SEE FIRST SHEET FOR CONTRACT NUMBER. USE OR DISCLOSURE OF INFORMATION ON THIS SHEET IS SUBJECT TO THE RESTRICTIONS ON THE FIRST SHEET OF THIS DOCUMENT.	SIZE: D	CAGE CODE: 1WYD3	DWG NO: 9003020-003	REV: -
	SCALE: NONE	SHEET 18		SHEET 18	

REV	DESCRIPTION

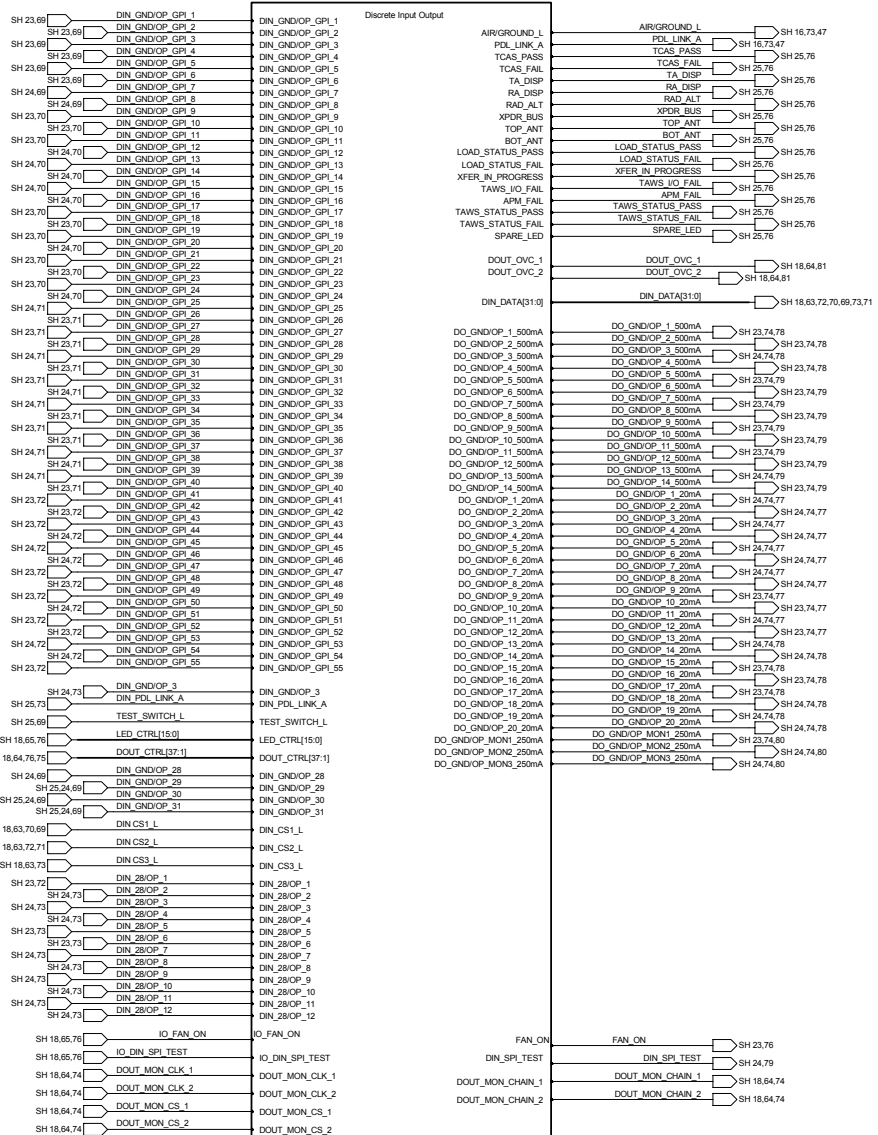

DISCRETE INPUT/OUTPUT - TOP VIEW
 COMMON PROCESSOR ASSEMBLY - TOP
 SHEET NO. 4 OF 13

COMPUTER GENERATED

ACSS	SEE FIRST SHEET FOR CONTRACT NUMBER. USE OR DISCLOSURE OF INFORMATION ON THIS SHEET IS SUBJECT TO THE RESTRICTIONS ON THE FIRST SHEET OF THIS DOCUMENT.	SIZE D	CAGE CODE 1WYD3	DWG. NO. 9003020-003	REV -
	SCALE: NONE	SHEET 19		SHEET 19	

REVISIONS	
REV	DESCRIPTION

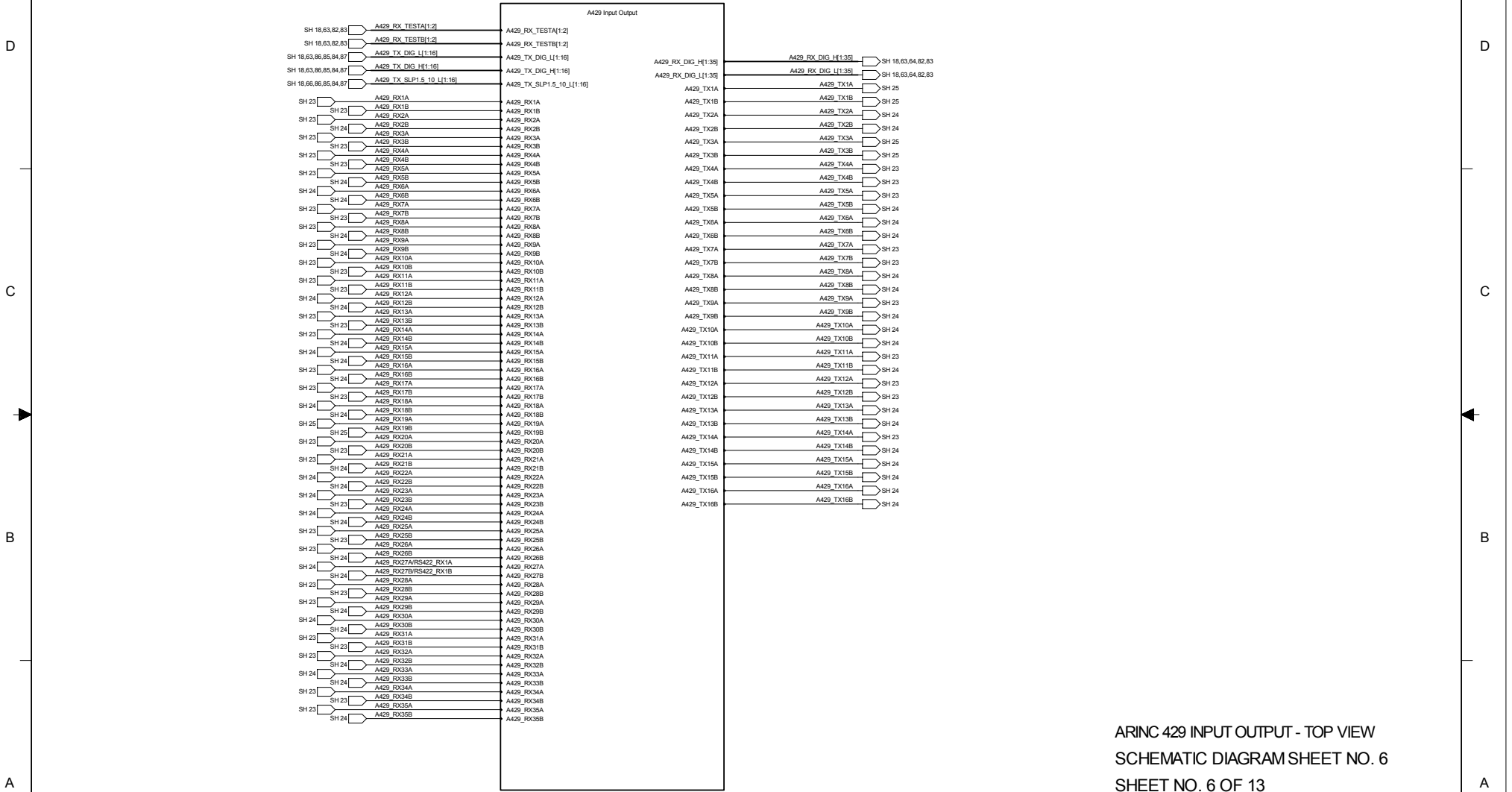

SHEET 82 - 87

ARINC 429 INPUT OUTPUT - TOP VIEW
 SCHEMATIC DIAGRAM SHEET NO. 6
 SHEET NO. 6 OF 13

COMPUTER GENERATED

ACSS	SEE FIRST SHEET FOR CONTRACT NUMBER. USE OR DISCLOSURE OF INFORMATION ON THIS SHEET IS SUBJECT TO THE RESTRICTIONS ON THE FIRST SHEET OF THIS DOCUMENT.	SIZE D	CAGE CODE 1WYD3	DWG NO. 9003020-003	REV -
	SCALE: NONE	SHEET 20			

REVISONS	
REV	DESCRIPTION

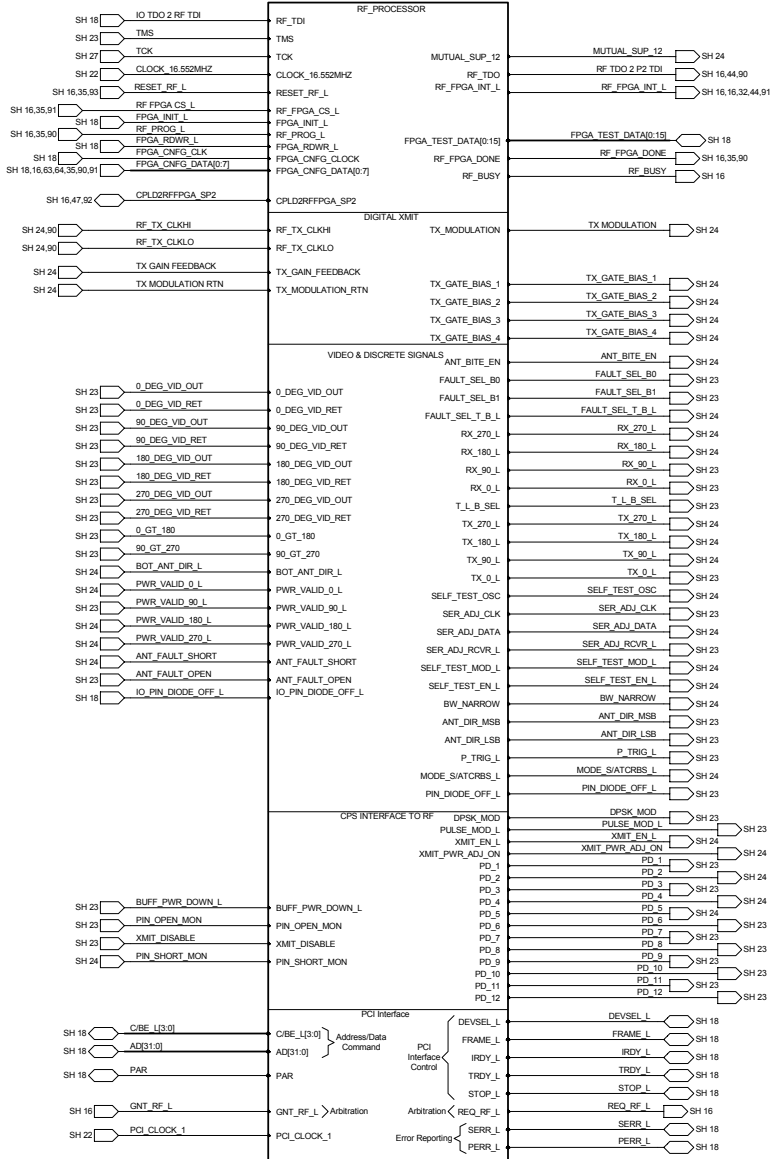

SHEET 88 - 96

RF INTERFACE - TOP VIEW
 COMMON PROCESSOR ASSEMBLY - TOP
 SHEET NO. 7 OF 13

COMPUTER GENERATED

DWG. NO.	9003020-003	SH. 22	REV. 1
		REVISIONS	
REV.	DESCRIPTION		

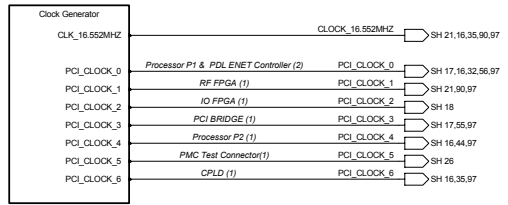

SHEET 97

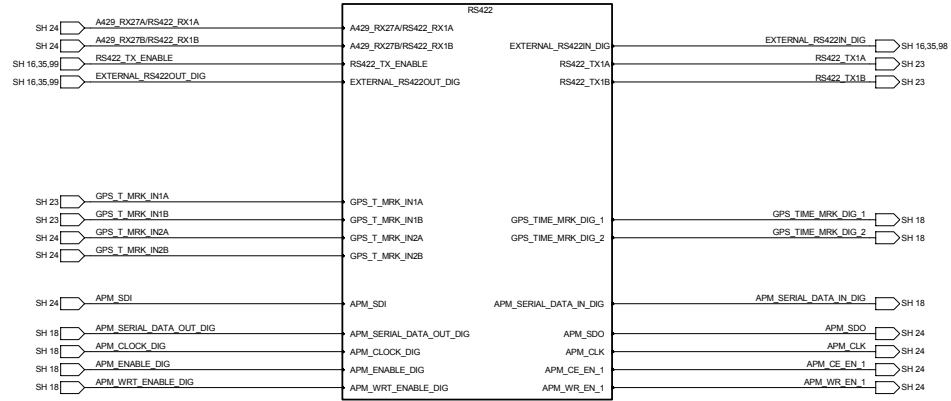

SHEET 98 - 99

CLOCK GENERATION & RS422 TX/RX - TOP VIEW
 COMMON PROCESSOR ASSEMBLY - TOP
 SHEET NO. 8 OF 13

COMPUTER GENERATED

ACSS	SEE FIRST SHEET FOR CONTRACT NUMBER. USE OR DISCLOSURE OF INFORMATION ON THIS SHEET IS SUBJECT TO THE RESTRICTIONS ON THE FIRST SHEET OF THIS DOCUMENT.	SIZE	CAGE CODE	DWG. NO.	REV.
		D	1WYD3	9003020-003	-
SCALE: NONE		SHEET 22			

REV	DESCRIPTION

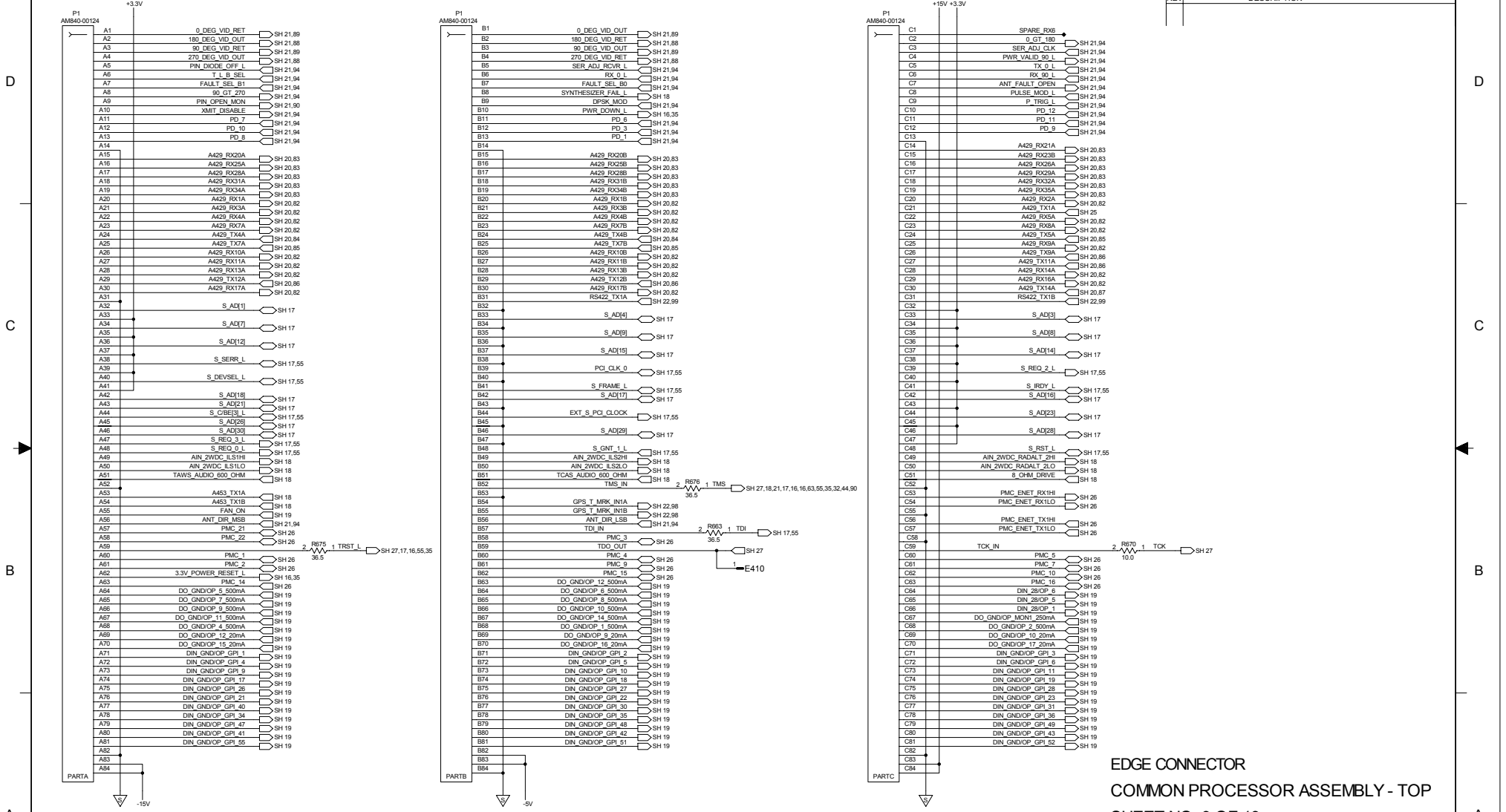

EDGE CONNECTOR
 COMMON PROCESSOR ASSEMBLY - TOP
 SHEET NO. 9 OF 13

COMPUTER GENERATED

ACSS	SEE FIRST SHEET FOR CONTRACT NUMBER. USE OR DISCLOSURE OF INFORMATION ON THIS SHEET IS SUBJECT TO THE RESTRICTIONS ON THE FIRST SHEET OF THIS DOCUMENT.	SIZE D	CAGE CODE 1WYD3	DWG NO. 9003020-003	REV -
	SCALE: NONE		SHEET 23		

REVISONS	
REV	DESCRIPTION

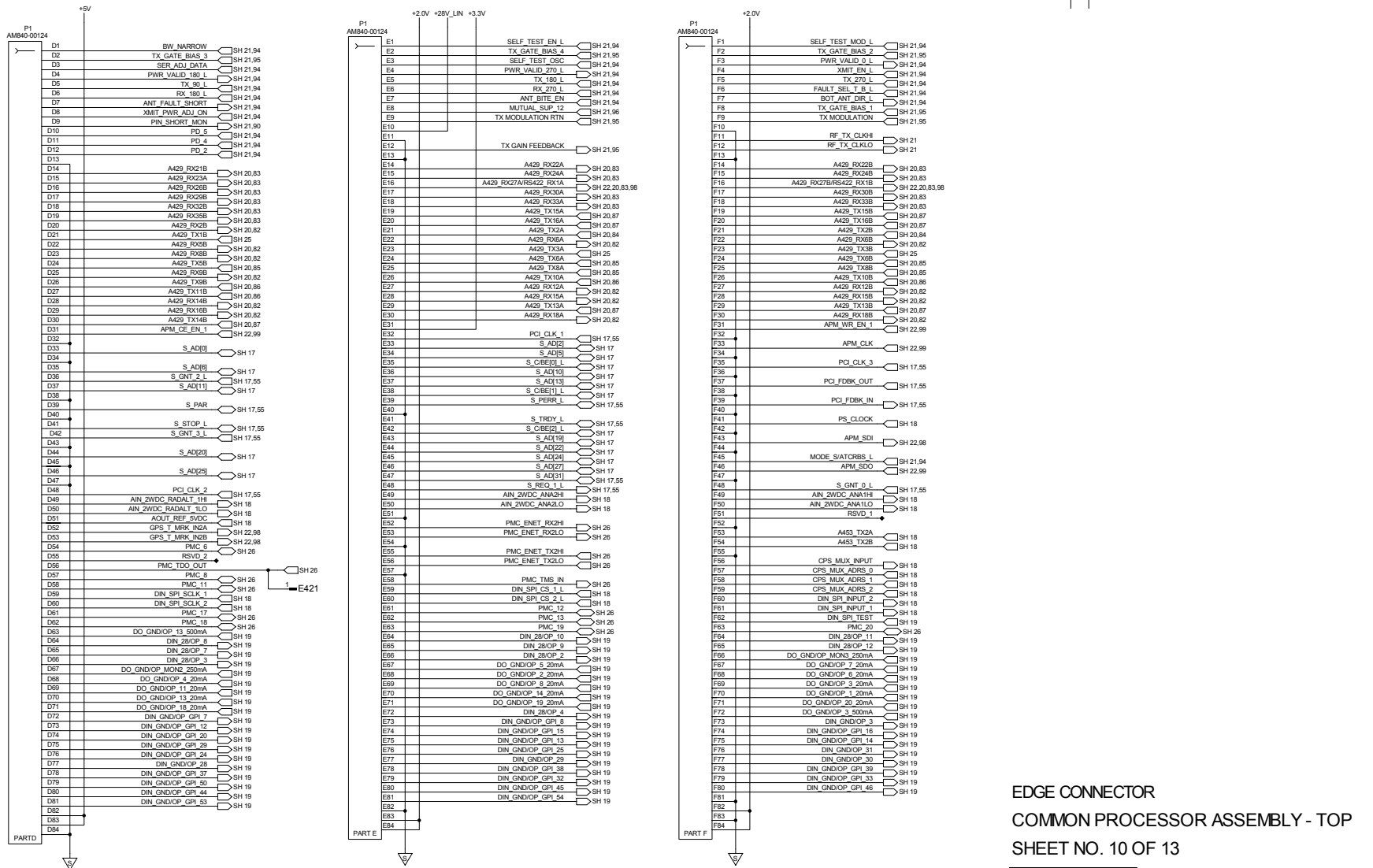

EDGE CONNECTOR
 COMMON PROCESSOR ASSEMBLY - TOP
 SHEET NO. 10 OF 13

COMPUTER GENERATED

ACSS	SEE FIRST SHEET FOR CONTRACT NUMBER, USE OR DISCLOSURE OF INFORMATION ON THIS SHEET IS SUBJECT TO THE RESTRICTIONS ON THE FIRST SHEET OF THIS DOCUMENT.	SIZE: D	CAGE CODE: 1WYD3	DWG NO.: 9003020-003	REV: -
	SCALE: NONE	SHEET 24			

REVISIONS	
REV	DESCRIPTION

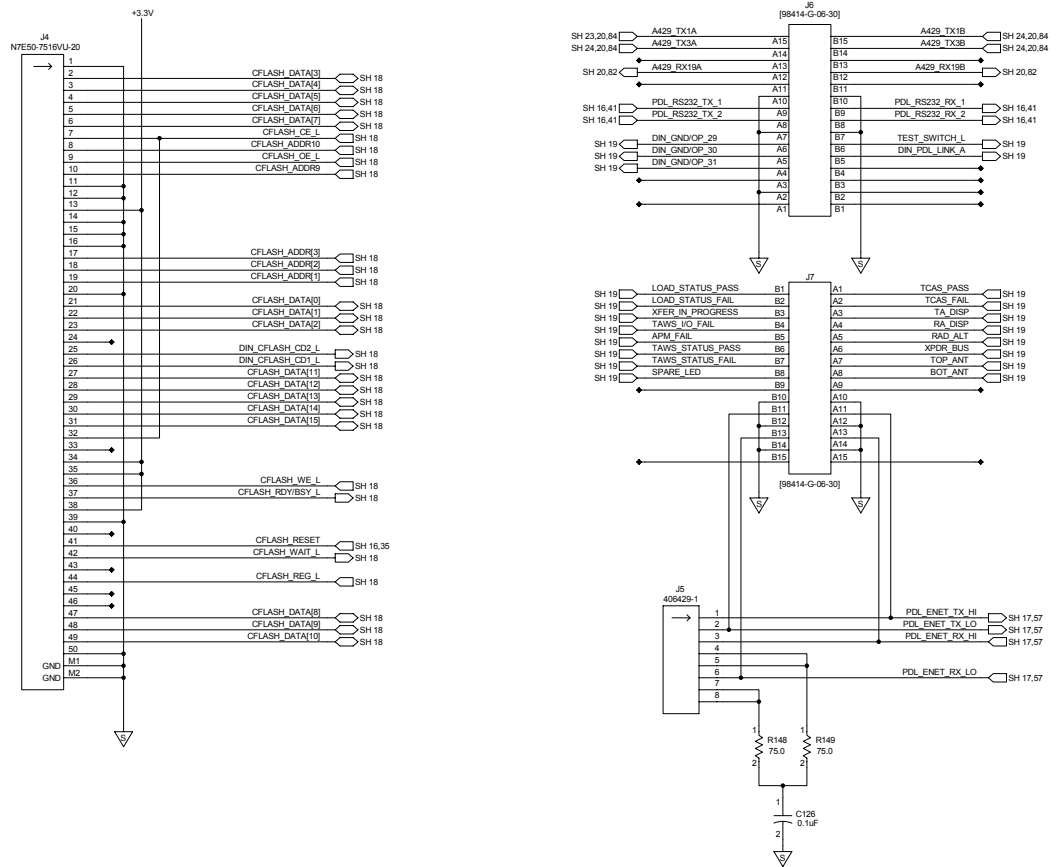

COMPACT FLASH, ETHERNET, & PDL
CONNECTORS
COMMON PROCESSOR ASSEMBLY - TOP
SHEET NO. 11 OF 13

COMPUTER GENERATED

REVISONS	
REV	DESCRIPTION

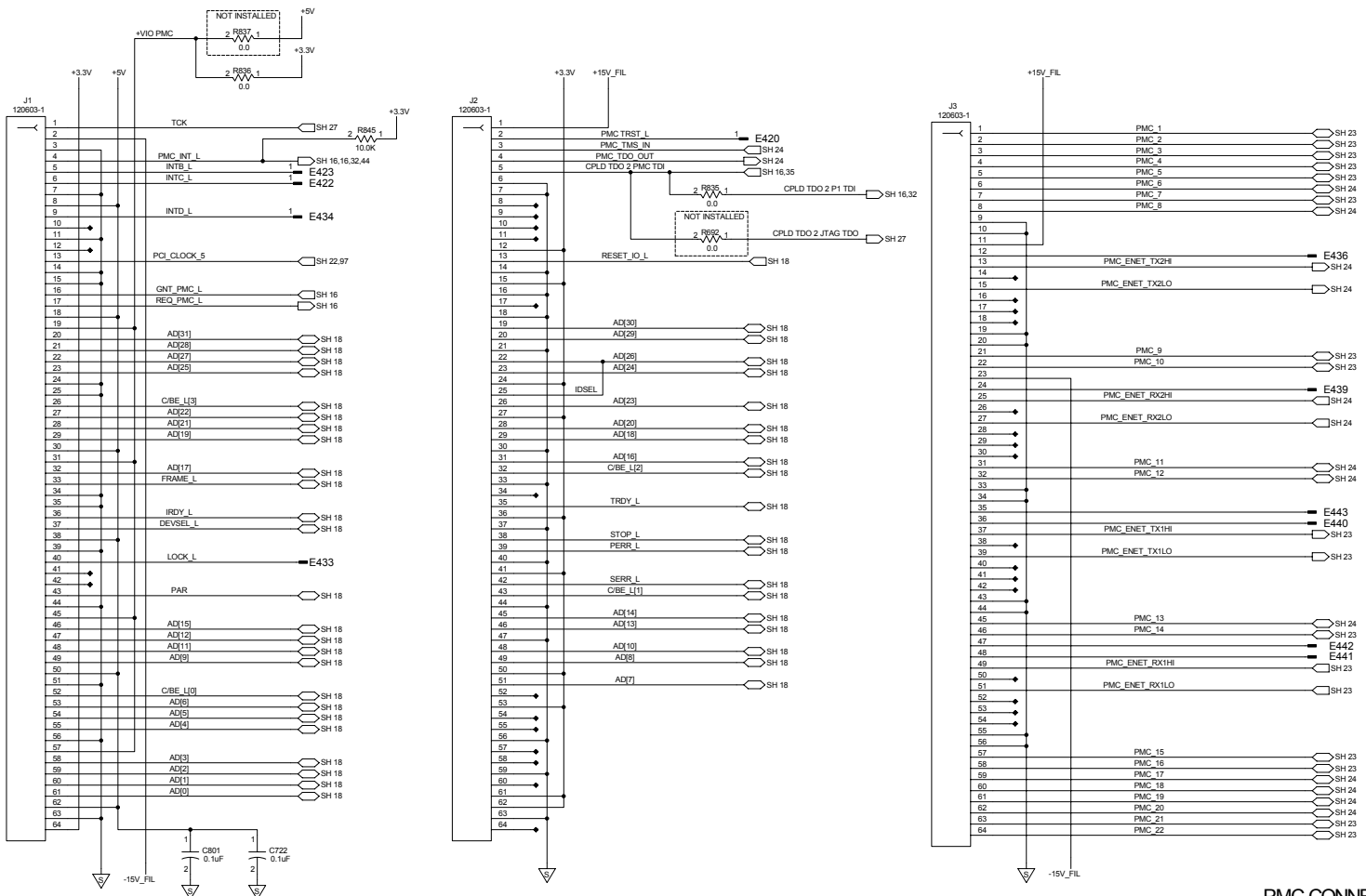

PMC CONNECTORS
 COMMON PROCESSOR ASSEMBLY - TOP
 SHEET NO. 12 OF 13

COMPUTER GENERATED

DWG. NO.	9003020-003	SHEET	27	REV	
REVISIONS					
REV	DESCRIPTION				

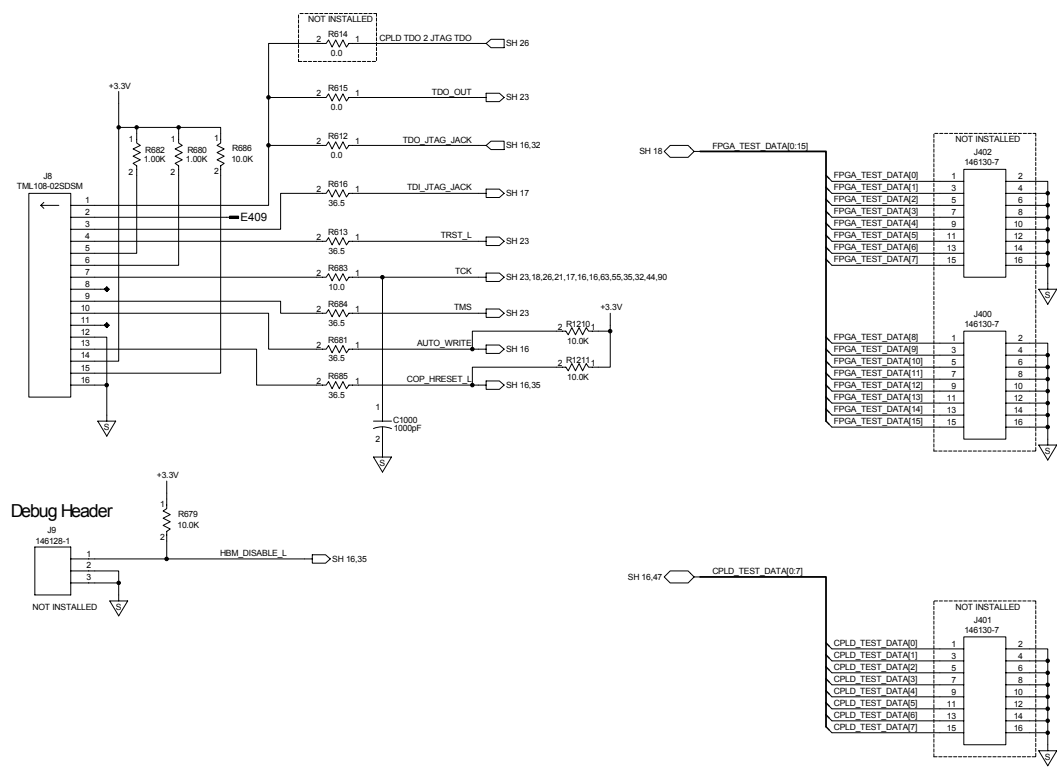

TEST, PROGRAMMING & DEBUG CONNECTORS
COMMON PROCESSOR ASSEMBLY - TOP
SHEET NO. 13 OF 13

COMPUTER GENERATED

ACSS	SEE FIRST SHEET FOR CONTRACT NUMBER. USE OR DISCLOSURE OF INFORMATION ON THIS SHEET IS SUBJECT TO THE RESTRICTIONS ON THE FIRST SHEET OF THIS DOCUMENT.		SIZE	D	CAGE CODE	1WYD3	DWG. NO.	9003020-003	REV	-
	SCALE: NONE		SHEET		27					

REVISIONS	
REV	DESCRIPTION

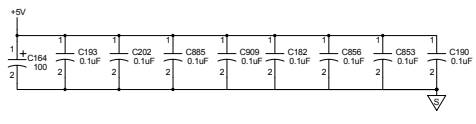
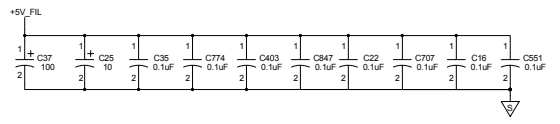
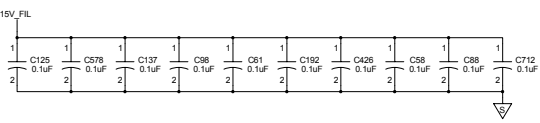
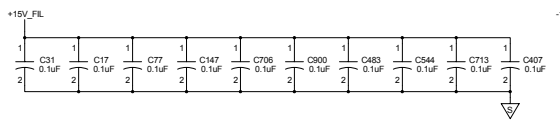
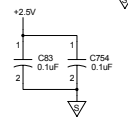
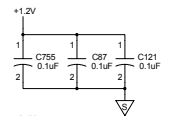
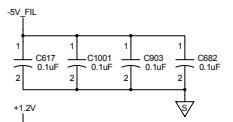
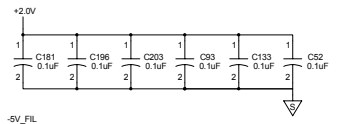
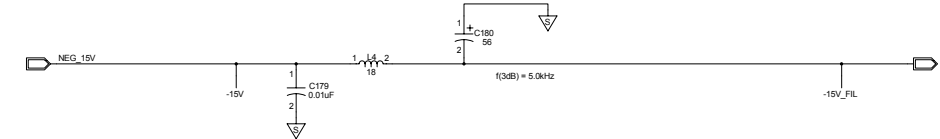
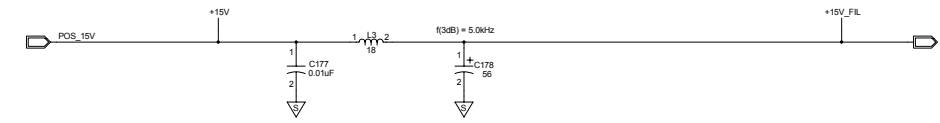
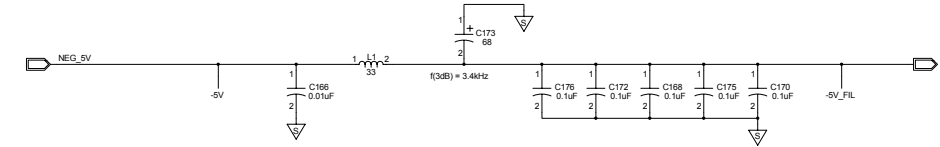
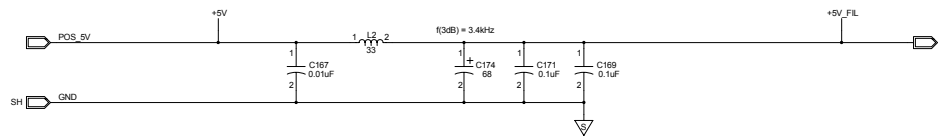

POWER SUPPLY FILTER
DECOUPLING CAPACITORS
SHEET NO. 1 OF 1

COMPUTER GENERATED

ACSS	SEE FIRST SHEET FOR CONTRACT NUMBER. USE OR DISCLOSURE OF INFORMATION ON THIS SHEET IS SUBJECT TO THE RESTRICTIONS ON THE FIRST SHEET OF THIS DOCUMENT.	SIZE	CAGE CODE	DWG. NO.	REV
		D	1WYD3	9003020-003	-
SCALE: NONE		SHEET		28	

REVISIONS	
REV	DESCRIPTION

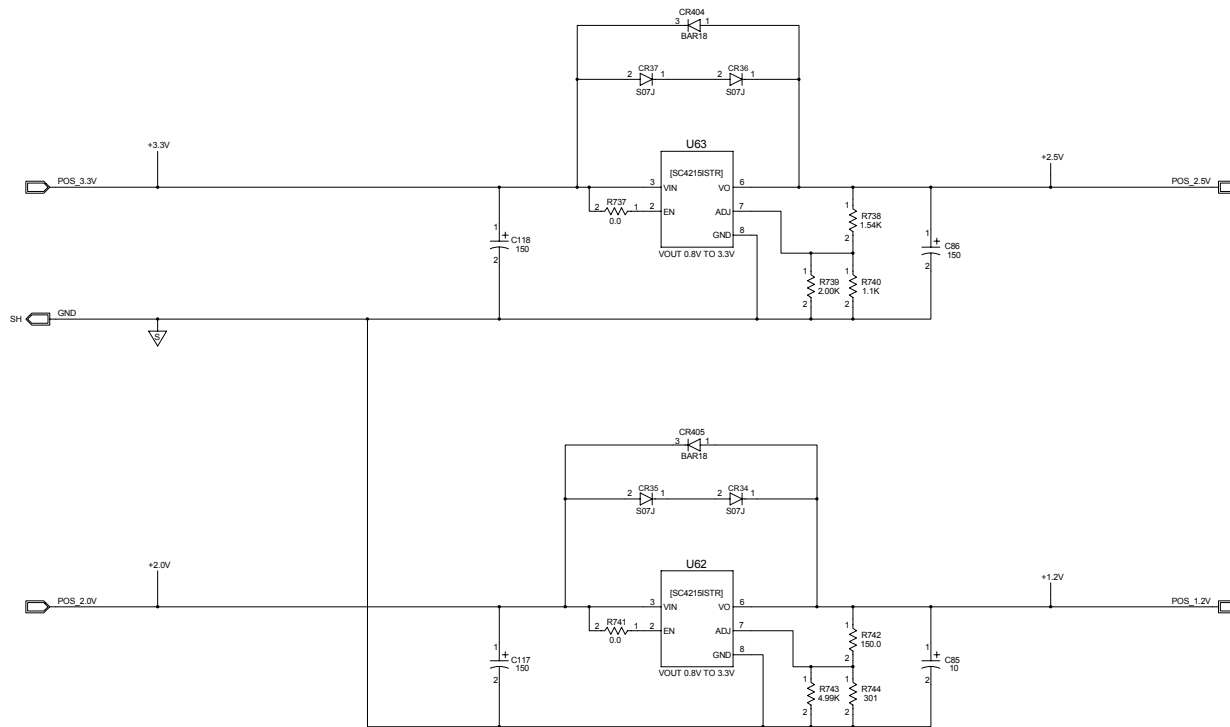

CORE POWER SUPPLY
SHEET NO. 1 OF 1

COMPUTER GENERATED

REVISIONS	
REV	DESCRIPTION

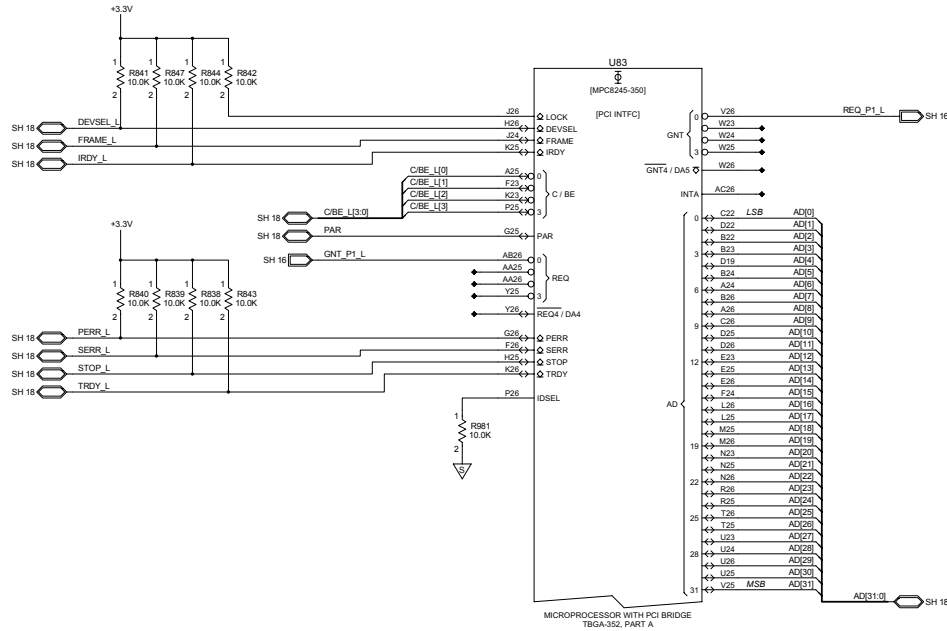

Note:
When external arbiter is used REQ0 becomes the PCI GNT input pin and GNT0 becomes the PCI REQ output pin.

P1 PROCESSOR - MPC8245
PCI INTERFACE
SHEET NO. 1 OF 12

COMPUTER GENERATED

ACSS	SEE FIRST SHEET FOR CONTRACT NUMBER. USE OR DISCLOSURE OF INFORMATION ON THIS SHEET IS SUBJECT TO THE RESTRICTIONS ON THE FIRST SHEET OF THIS DOCUMENT.	SIZE: D	CAGE CODE: 1WYD3	DWG. NO.: 9003020-003	REV: -
	SCALE: NONE	SHEET: 30			

REVISIONS	
REV	DESCRIPTION

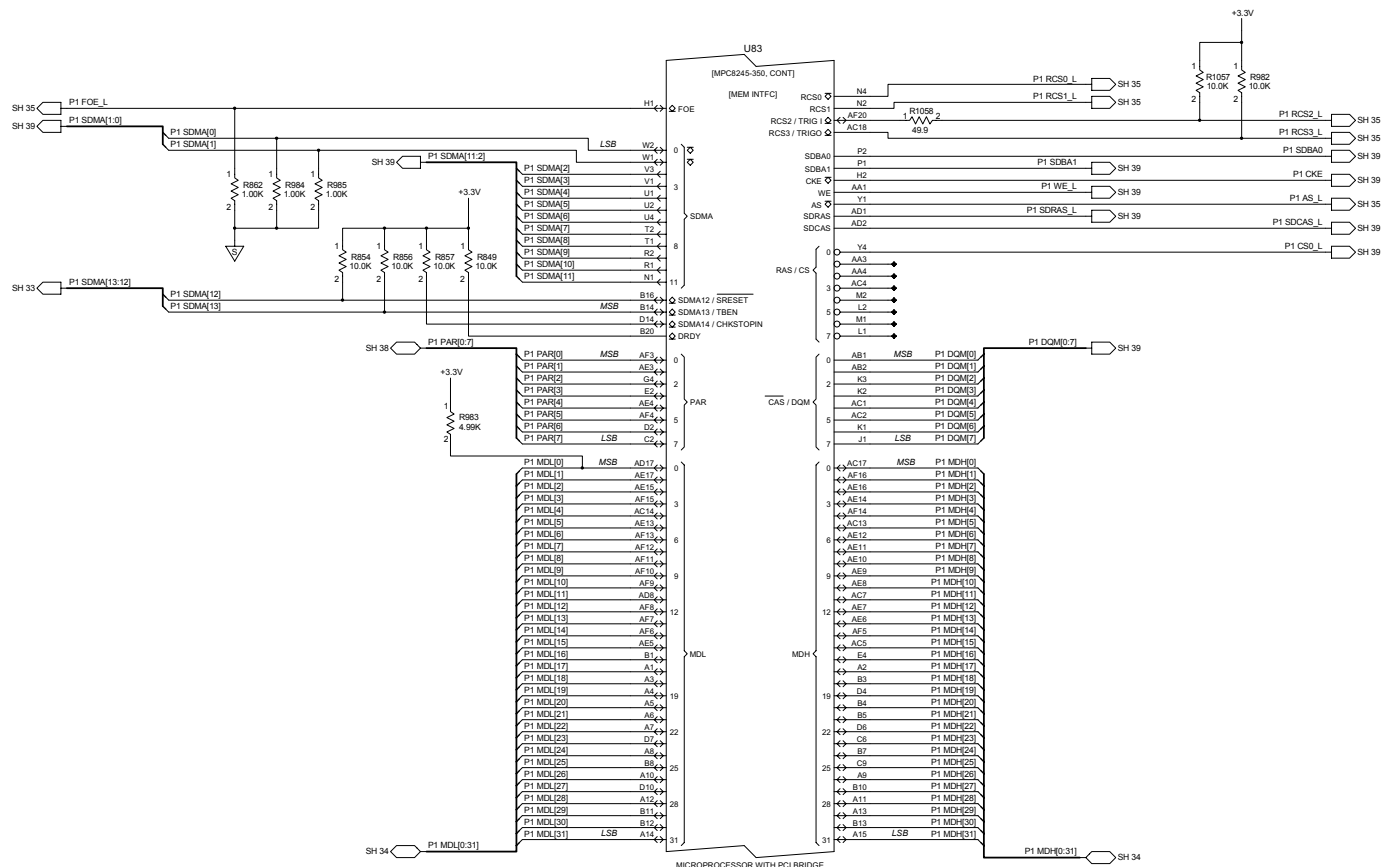

P1 PROCESSOR - MPC8245
 MEMORY INTERFACE
 SHEET NO. 2 OF 12

COMPUTER GENERATED

REVISIONS	
REV	DESCRIPTION

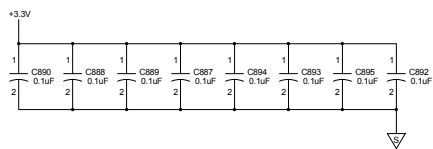
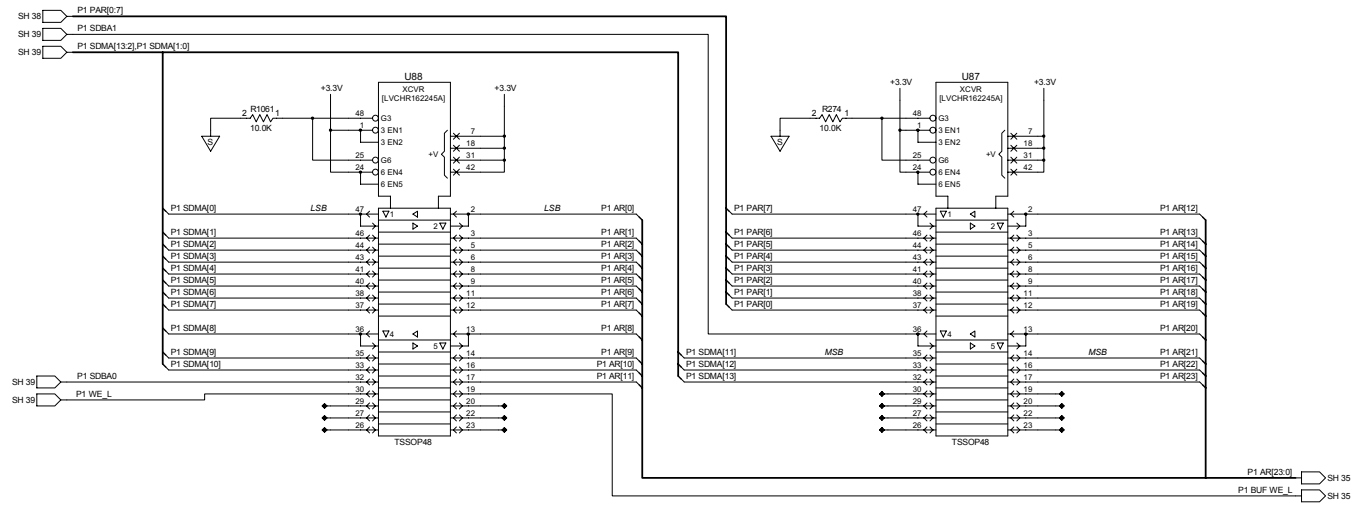

P1 PROCESSOR - ADDRESS BUS BUFFERS
SHEET NO. 4 OF 12

COMPUTER GENERATED

REVISONS	
REV	DESCRIPTION

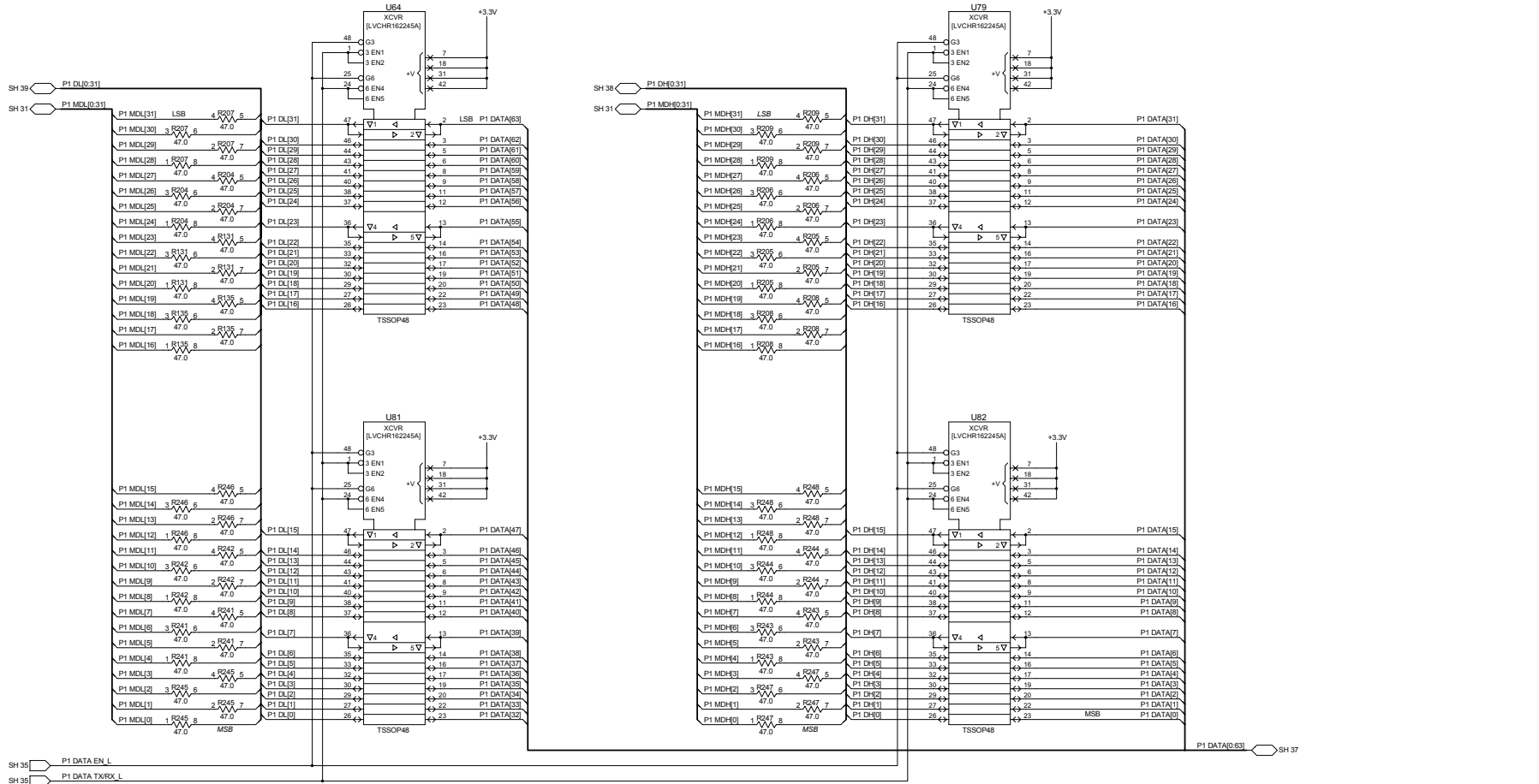

SH 35 P1 DATA EN L
SH 35 P1 DATA TXRX L

P1 PROCESSOR - DATA BUS BUFFERS
SHEET NO. 5 OF 12

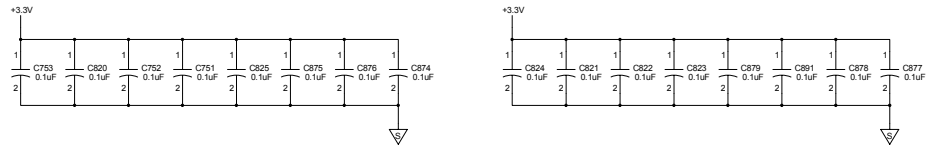

COMPUTER GENERATED

ACSS	SEE FIRST SHEET FOR CONTRACT NUMBER. USE OR DISCLOSURE OF INFORMATION ON THIS SHEET IS SUBJECT TO THE RESTRICTIONS ON THE FIRST SHEET OF THIS DOCUMENT.	SIZE: D	CAGE CODE: 1WYD3	DWG. NO.: 9003020-003	REV: -
	SCALE: NONE	SHEET 34			

REVISIONS			
CRNO.	REV.	DESCRIPTION	
008589	A	Change U51 to part number 9000621-003.	05-05-05
008677	B	Change U51 to part number 9000621-004.	08-29-05
008969	C	Change U51 to part number 9000621-005.	09-14-05

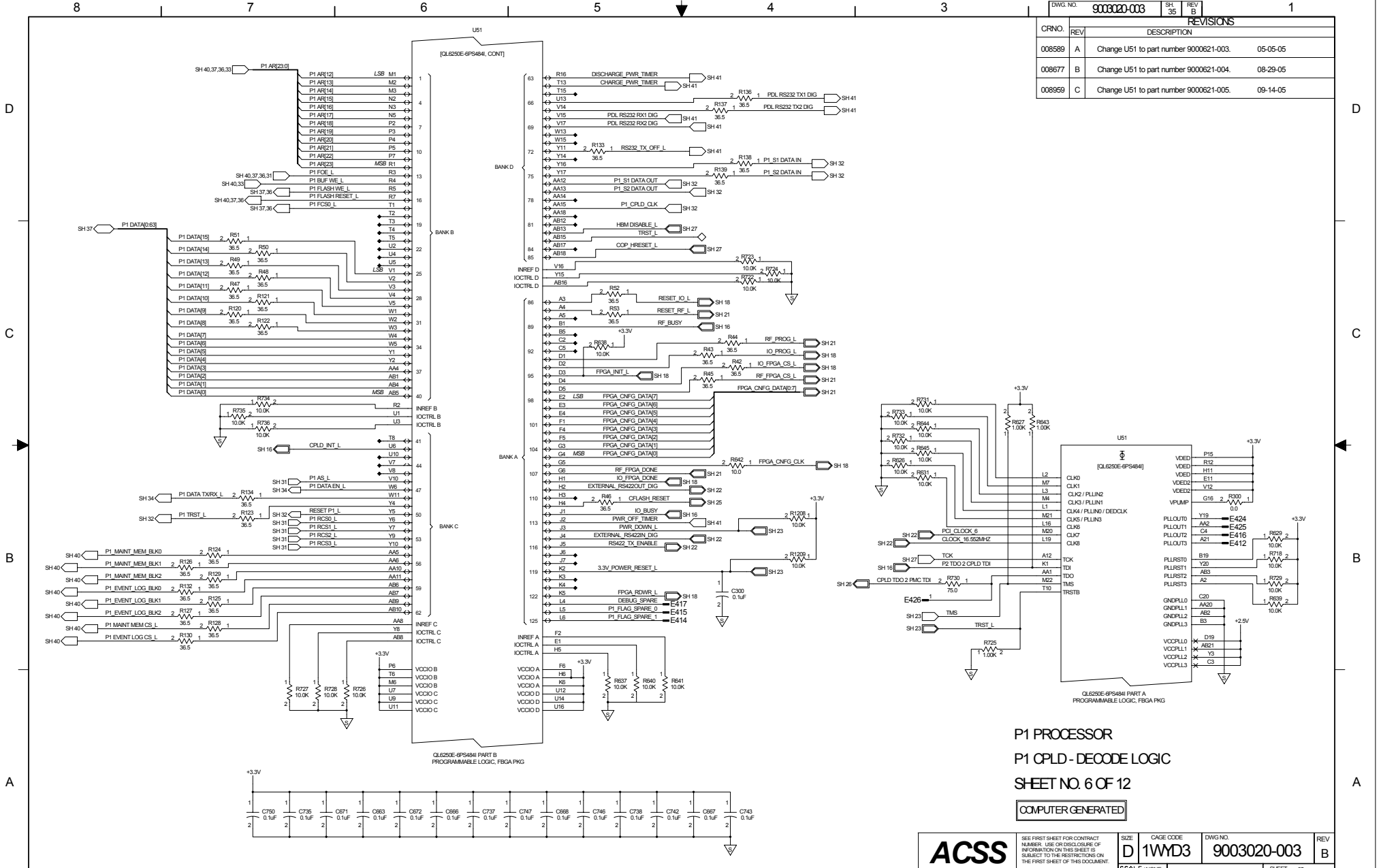

P1 PROCESSOR
P1 CPLD - DECODE LOGIC
SHEET NO. 6 OF 12

COMPUTER GENERATED

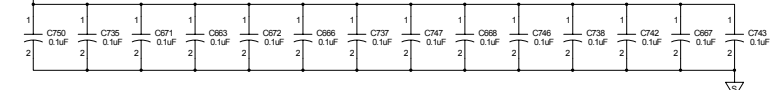

REVISONS	
REV	DESCRIPTION

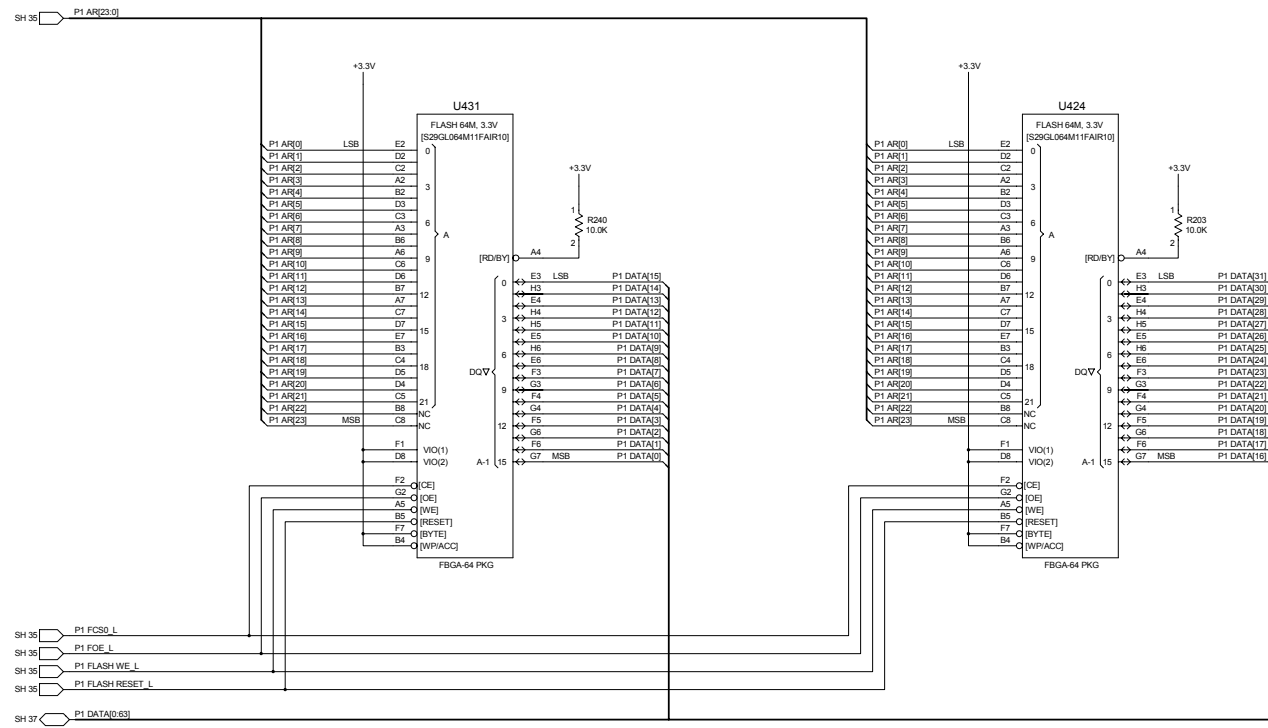

P1 PROCESSOR
P1 FLASH MEMORY - BANK 1 (1 OF 2)
64M BYTES
SHEET NO. 7 OF 12

COMPUTER GENERATED

REVISIONS	
REV	DESCRIPTION

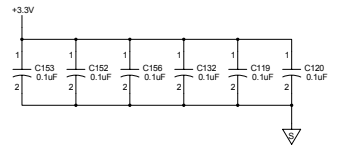
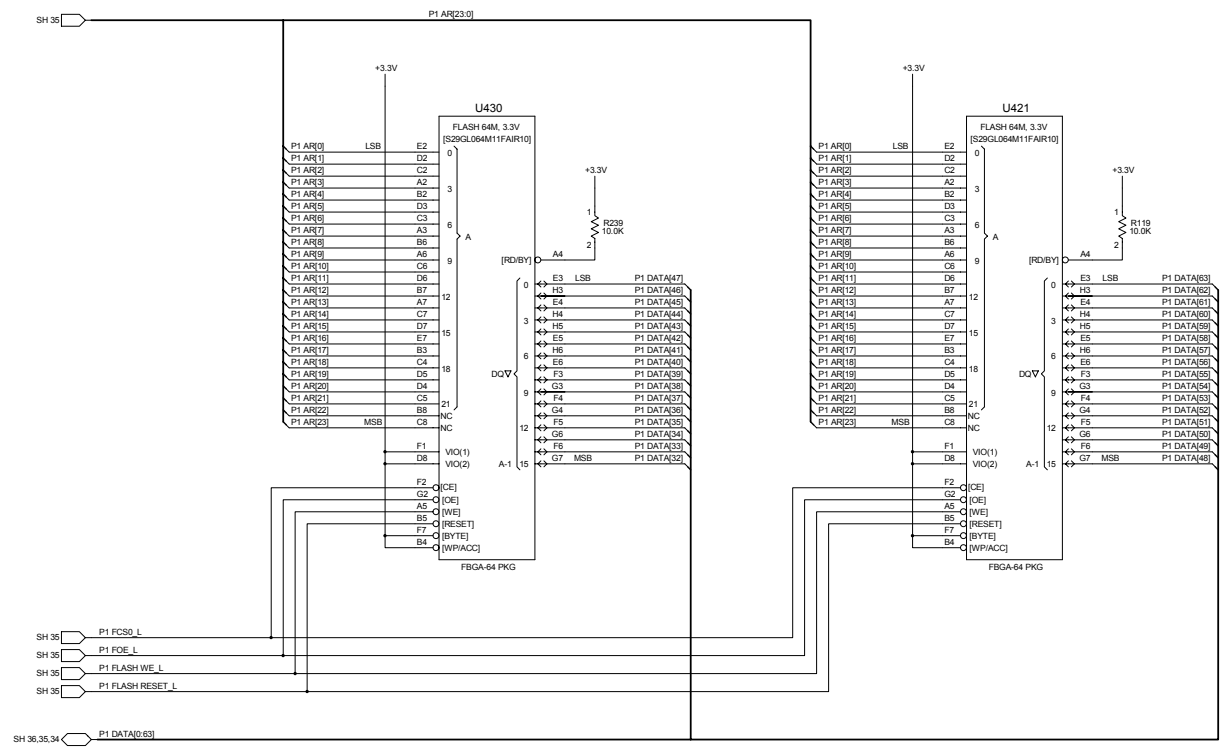

P1 PROCESSOR
P1 FLASH MEMORY - BANK 1 (2 OF 2)
SHEET NO. 8 OF 12

COMPUTER GENERATED

ACSS	SEE FIRST SHEET FOR CONTRACT NUMBER. USE OR DISCLOSURE OF INFORMATION ON THIS SHEET IS SUBJECT TO THE RESTRICTIONS ON THE FIRST SHEET OF THIS DOCUMENT.	SIZE: D	CAGE CODE: 1WYD3	DWG. NO.: 9003020-003	REV: -
	SCALE: NONE	SHEET: 37			

REVISIONS	
REV	DESCRIPTION

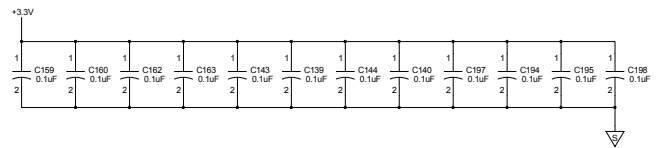
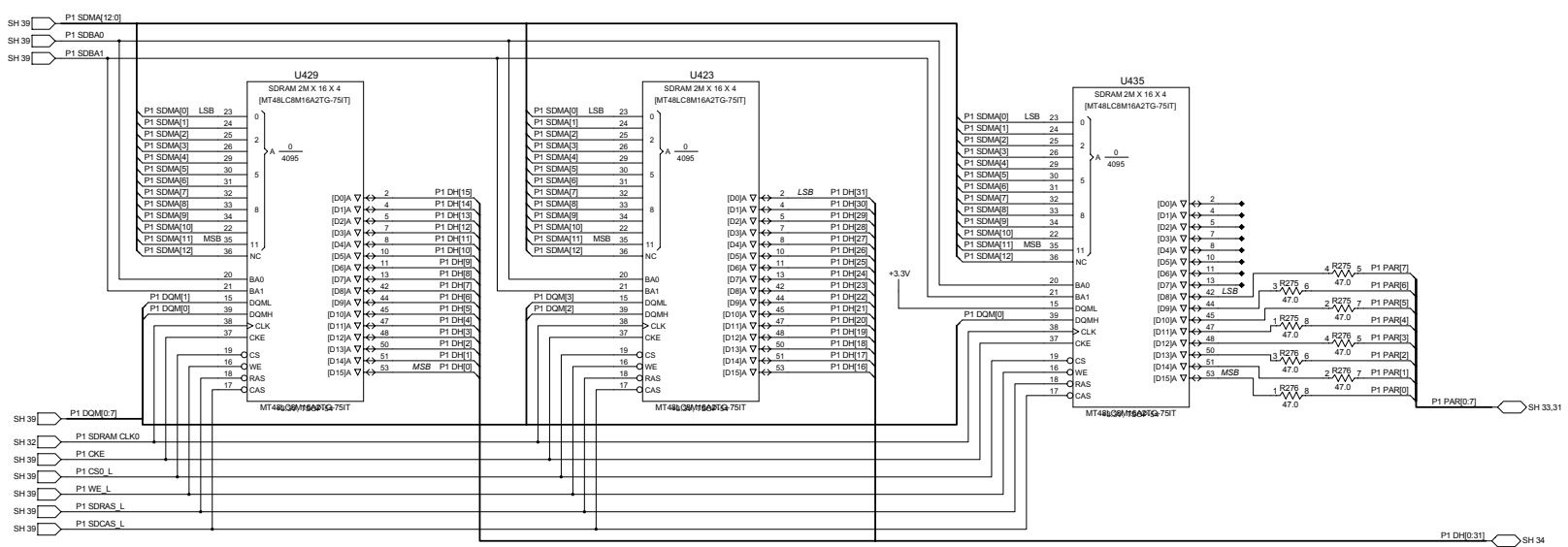

P1 PROCESSOR
P1 SDRAM MEMORY - 64M BYTES (1 OF 2)
P1 SDRAM ECC - 16M BYTES
SHEET NO. 9 OF 12

COMPUTER GENERATED

REVISIONS	
REV	DESCRIPTION

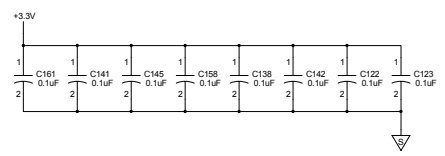
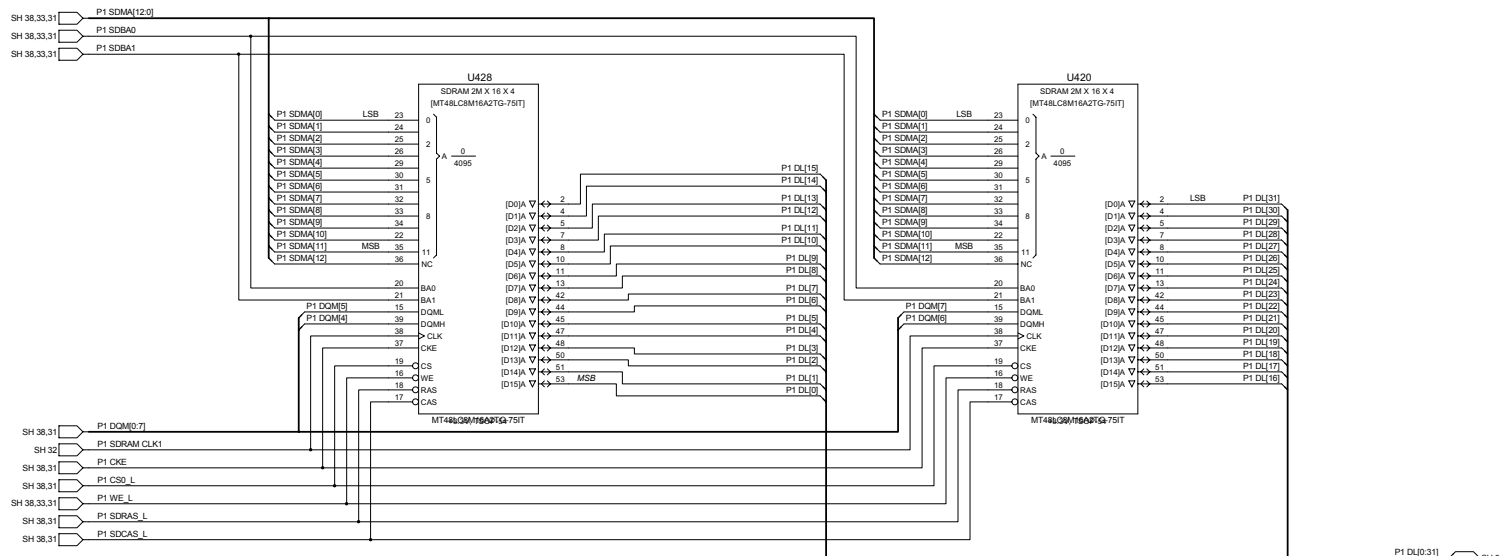

P1 PROCESSOR
P1 SDRAM MEMORY - 64M BYTES (2 OF 2)
SHEET NO. 10 OF 12

COMPUTER GENERATED

DWG. NO.	9003020-003	SH.	40	REV.	
REVISIONS					
REV.	DESCRIPTION				

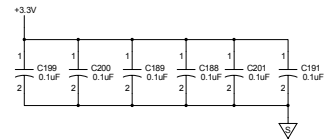
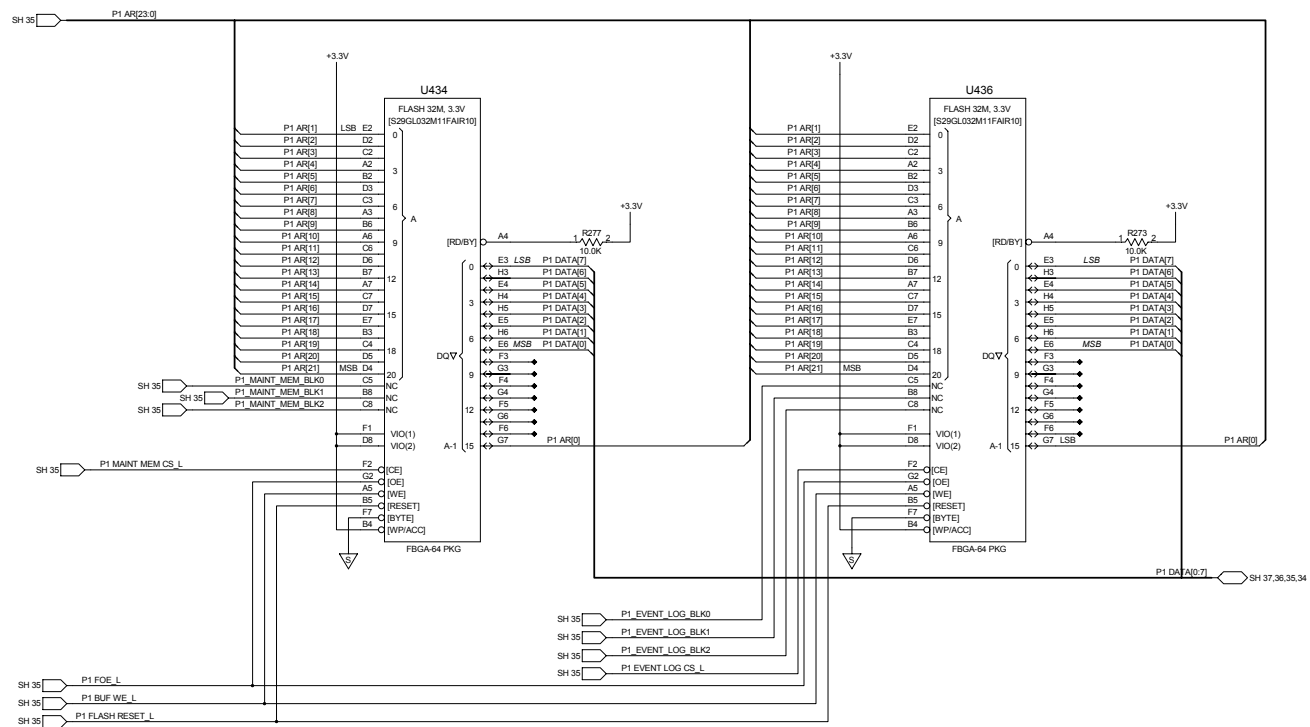

P1 PROCESSOR
P1 MAINTENANCE MEMORY - 4M BYTES FLASH
P1 EVENT LOG MEMORY - 4M BYTES FLASH
SHEET NO. 11 OF 12

COMPUTER GENERATED

ACSS	SEE FIRST SHEET FOR CONTRACT NUMBER. USE OR DISCLOSURE OF INFORMATION ON THIS SHEET IS SUBJECT TO THE RESTRICTIONS ON THE FIRST SHEET OF THIS DOCUMENT.	SIZE	D	CAGE CODE	1WYD3	DWG. NO.	9003020-003	REV.	-
	SCALE	NONE				SHEET		40	