

# Measurement Report

**FCC ID:P6XSBX-166LHGE-5**This report concerns (check one) :  Original Grant  Class II Change

Issued Date : Oct. 11, 2006

Project No. : 0602056C

Equipment : Safe@Office/VPN-1 Edge

Model No. : SBXD-166LHGE-5; SBX-166LHGE-5

Applicant : SofaWare Technology Ltd.

3 Hilazon St, Ramat-Gan, 52522, Israel

**Tested by:**

Neutron Engineering Inc. EMC Laboratory

**Data of Test:**

Feb. 16, 2006 ~ Mar. 02, 2006

Testing Engineer :

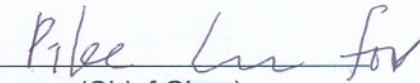
  
(Chief Chau)

Technical Manager :

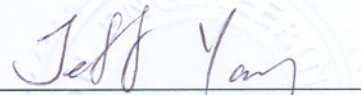
  
(Jeff Yang)

Authorized Signatory :

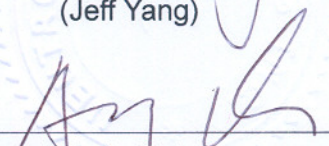
  
(Andy Chiu)**NEUTRON ENGINEERING INC.**No. 132-1, Lane 329, Sec. 2, Palain Rd.,  
Shijr City, Taipei, Taiwan

TEL : (02) 2646-5426 FAX : (02) 2646-6815



**Declaration**

**Neutron** represents to the client that testing is done in accordance with standard procedures as applicable and that test instruments used has been calibrated with the standards traceable to National Measurement Laboratory., or National Institute of Standards and Technology (**NIST**) of **U.S.A.**

**Neutron's** reports apply only to the specific samples tested under conditions. It is manufacture's responsibility to ensure that additional production units of this model are manufactured with the identical electrical and mechanical components. **Neutron** shall have no liability for any declarations, inferences or generalizations drawn by the client or others from **Neutron** issued reports.

**Neutron's** reports must not be used by the client to claim product endorsement by the authorities or any agency of the Government.

This report is the confidential property of the client. As a mutual protection to the clients, the public and **Neutron-self**, extracts from the test report shall not be reproduced except in full with **Neutron's** authorized written approval.

**Neutron's** laboratory quality assurance procedures are in compliance with the **ISO Guide 17025** requirements, and accredited by the conformity assessment authorities listed in this test report.

**Limitation**

For the use of the authority's logo is limited unless the Test Standard(s)/Scope(s)/Item(s) mentioned in this test report is (are) included in the conformity assessment authorities acceptance respective.

Table of Contents	Page
<b>1 . General Information</b>	<b>5</b>
1.1 Applicant / Manufacturer	5
1.2 Factory	5
1.3 Equipment Under Tested	5
1.4 OEM Brand/Model	5
1.5 Model Difference	5
1.6 Product Descriptions	6
1.7 Connecting I/O Port(s)	6
1.8 Power Supplied	6
1.9 Products Covered	6
1.10 Description of Test Mode(s)	6
1.11 EUT Modifications	6
1.12 Summary of Test Results	7
<b>2 . RFI Emissions Measurement</b>	<b>8</b>
2.1 Test Facility	8
2.2 Standard Compliance	8
2.3 Test Methodology	8
2.4 Deviations from Standard Test Method	8
2.5 Sample(s) Tested	8
2.6 Measurement Instruments	8
2.7 Measurement Uncertainty	9
2.8 Tested System Set-Up/Configuration Details	9
2.9 EUT Operating Conditions	13
<b>3 . Justification</b>	<b>14</b>
3.1 Limitations	14
3.1.1 Power Line Conducted Emission	14
3.1.2 Radiated Emission Limits	14
3.2 Measurement Justification	15
3.2.1 Conducted Emission	15
3.2.2 Radiated Emission	15
3.3 Measurement Data	15
Table 4 Conducted Emission Data	16
Table 5 Radiated Emission Data	20

**Table of Contents**

**Page**

**Attachment**

24

Attachment - A

25

Attachment - B

30

**1. General Information**

1.1 Applicant / Manufacturer

Name : SofaWare Technology Ltd.  
 Address : 3 Hilazon St, Ramat-Gan, 52522, Israel

1.2 Factory

Name : Turbocomm  
 Address : No. 369. Sec. 3. Chun Cheng East Road. Wu Chuan Tsun. Ta Yuan Hsiang, Tao Yuan Hsien 337. Taiwan.

1.3 Equipment Under Tested

Name : Safe@Office/VPN-1 Edge  
 Trade Name : SofaWare  
 Model No. : SBXD-166LHGE-5; SBX-166LHGE-5

1.4 OEM Brand/Model (if applicable)

OEM Brand(s)/Model(s) except the basic model in sub-clause 1.3 is (are) the follows:  
 OEM Brand/Model : Check Point / SBXD-166LHGE-5; SBX-166LHGE-5  
 NOKIA / IP60\UTM appliance base

1.5 Model Difference (Series, Versions, if any)

Except the basic model no. (model designation of the sample tested in this test report), additional model no. covered is(are) :

1. There are three models based on similar electrical circuit except the difference of list below:

Function Model No.:	ADSL	USB	Router
SBXD-166LHGE-5	○	○	○
SBX-166LHGE-5	X	X	○
IP60\UTM appliance base	X	X	○

All the above models were tested and used for final testing and collecting test data included in this report.

2. The EUT include some component parts and they are put on similar position except the difference of manufactory and Model.

Component	Manufactory	Model
<b>Transformer (U17)</b>	DELTA	LFE8505
	MINGSTAR	TM1701MN
	MINGTEK	HN16012SG
<b>Power Inductor</b>	SUPER WORLD	PDB3316101MZF
	SUPER WORLD	PDB3340101MZF

All the above component parts were tested, and the model: TM1701MN & PDB3340101MZF were found to be the worst case during the pr-scanning test. These component parts of the worst case were used for final testing and collecting test data included in this report.

**1.6 Product Descriptions (Application/Features/Specification)**

The EUT is a Safe@Office/VPN-1 Edge.

Based on the application, features, or specification exhibited in User's Manual, the EUT is considered as an ITE/Computing Device. More details of EUT technical specification, please refer to the User's Manual

**1.7 Connecting I/O Port(s)**

Please refer to the User's Manual

**1.8 Power Supplied**

Power Source : AC Mains.

Power Cord : Permanently connected, non-shielded type.

Power Rating : AC I/P 120V, 60Hz, 19.3W / AC O/P 9V, 1.5A or DC O/P 12V, 1.5A

**1.9 Products Covered (if applicable)**

The sample tested including the following sub-system/module/accessory:

Sub-system/ Module/ Accessory	Model/Type No.	Model difference
AC Adaptor	AA-091A5BN	
AC Adaptor	AA-091A5D	There are six models based on similar electrical circuit except the difference of model designation.
AC Adaptor	AA-091A5E	
AC Adaptor	AA-091A5	
AC Adaptor	AA-091A5J	
AC Adaptor	AA-091A5P	
DC Adaptor	SYS1308-2412W2E	
DC Adaptor	SYS1308-2412W2A	
DC Adaptor	SYS1308-2412W3U	
DC Adaptor	SYS1308-2412W2C	
DC Adaptor	SYS1308-2412W2	

All the above power adapters were tested, and the model: AA-091A5, was found to be the worst case during the pr-scanning test. This power adapter of the worst case was used for final testing and collecting test data included in this report.

**1.10 Description of Test Mode(s)**

To investigate the maximum EMI emission characteristics generates from EUT, the test system was pre-scanning tested base on the consideration of following EUT operation mode or test configuration mode which possible have effect on EMI emission level. Each of these EUT operation mode(s) or test configuration mode(s) mentioned above was evaluated respectively.

Mode 1 : 10 to 10 MbPs

Mode 2 : 100 to 100 MbPs

The EUT system operated Mode 2, mentioned above was found to be the worst case during the pre-scanning test.

This operation mode was used for final testing and collecting test data included in this report.

**1.11 EUT Modifications (if applicable)**

No any modification required for the EUT to comply with the standards.

## 1.12 Summary of Test Results

Test procedures according to the technical standards:

<b>EMC Emission</b>				
Standard	Test Item	Limit	Judgment	Remark
FCC Part15, Subpart B CISPR 22:1997+A1: 2000	Conducted Emission	Class B	PASS	
	Radiated Emission	Class B	PASS	

## NOTE:

(1) "N/A" denotes test is not applicable in this Test Report

**2. RFI Emissions Measurement**

2.1 Test Facility

The test facilities used to collect the test data in this report is C01/OS02 at the location of No.132-1, Lane 329, Sec. 2, Palain Road, Shijr City, Taipei, Taiwan.

2.2 Standard Compliance

The test data contained in this report relate only to the item(s) listed below:

Limitation Class B

FCC Part15, Subpart B / CISPR 22:1997+A1: 2000

2.3 Test Methodology

Both conducted and radiated tests were performed during the max. EMI emission evaluation.

Antenna to EUT distance is 10 m.

Test procedures according to the technical standards:

FCC Part15, Subpart B / CISPR 22:1997+A1: 2000

2.4 Deviations from Standard Test Method

N/A

2.5 Sample(s) Tested

The representative sample tested in this reports is(are): SBXD-166LHGE-5; SBX-166LHGE-5

Test results in this test report relate only to the sample(s) tested.

The EUT has been tested according to the following environmental condition:

Input Power	120Vac/ 60Hz
Environmental Conditions	Please refer to the measurement data.

2.6 Measurement Instruments

Valid measurement instruments used in this report refer to **Table-1** enclosed.



**2.7 Measurement Uncertainty**

The reported uncertainty of measurement  $y \pm U$ , where expanded uncertainty  $U$  is based on a standard uncertainty multiplied by a coverage factor of  $k=2$ , providing a level of confidence of approximately **95 %**.

A. Conducted Measurement :5.05dB

B. Radiated Measurement :

Test Site	Method	Measurement Frequency Range	Ant. H / V	U , (dB)	NOTE
OS-01	ANSI	30MHz ~ 200MHz	H	4.59	
		30MHz ~ 200MHz	V	4.80	
		200MHz ~ 1,000MHz	H	4.47	
		200MHz ~ 1,000MHz	V	5.03	
OS-01	VCCI	30MHz ~ 200MHz	H	4.59	Only for VCCI Report
		30MHz ~ 200MHz	V	4.48	Only for VCCI Report
		200MHz ~ 1,000MHz	H	4.47	Only for VCCI Report
		200MHz ~ 1,000MHz	V	4.73	Only for VCCI Report
OS-02	ANSI	30MHz ~ 200MHz	H	4.34	
		30MHz ~ 200MHz	V	5.15	
		200MHz ~ 1,000MHz	H	5.28	
		200MHz ~ 1,000MHz	V	4.53	
OS-02	VCCI	30MHz ~ 200MHz	H	4.34	Only for VCCI Report
		30MHz ~ 200MHz	V	4.77	Only for VCCI Report
		200MHz ~ 1,000MHz	H	4.91	Only for VCCI Report
		200MHz ~ 1,000MHz	V	4.53	Only for VCCI Report

**2.8 Tested System Set-Up/Configuration Details**

The system was configured for testing in a typical fashion (as a user would normally use) or in-accordance with the operating configuration specified in the user's manual. A Block Diagram (please refer to the Diagram - 1) and Photos (please refer to the attachment - **A**) showing the set-up/configuration of system tested. In addition, **Table-2** and **Table-3** provide a detail of all equipment items and cables information used in the system tested.

Table 1 Measurement Instruments List

Item	Instruments	Mfr/Brand	Model/Type No.	Serial No.	Calibrated Date	Next Cali. Date	Note
1	LISN	EMCO	3825/2	9605-2539	2005-10-03	2006-10-02	
2	LISN	Rolf Heine	NNB-2/16Z	98083	2005-08-02	2006-08-01	
3	LISN	Rolf Heine	NNB-2/16Z	98053	2005-12-20	2006-12-19	✓
4	4L-V-LISN	Rolf Heine	NNB-4/63TL	02/10040	2005-04-08	2006-04-07	
5	LISN	EMCO	3816/2	00042991	2006-01-11	2007-01-10	
6	LISN	EMCO	3816/2	00042990	2006-01-11	2007-01-10	
7	LISN	EMCO	4825/2	00028234	2005-10-25	2006-10-24	
8	LISN	Rolf Heine	LN-KFZ-200	02/10000	2006-03-28	2006-03-27	
9	LISN	Schwarzbeck	NNBM 8126D	137	2005-10-21	2006-10-20	
10	ISN	SCHAFFNER	ISN T400	16017	2005-04-01	2007-03-31	
11	Pulse Limiter	Electro-Metrics	EM-7600	112644	2005-11-30	2006-11-29	✓
12	50Ω Terminator	N/A	N/A	N/A	2005-05-12	2007-05-11	
13	Test Cable	N/A	C01	N/A	2005-11-30	2006-11-29	✓
14	Test Cable	N/A	SR03_C	N/A	2005-10-01	2006-09-30	
15	Test Cable	N/A	CISPR 14	N/A	2005-10-03	2006-10-02	
16	Log-Bicon Antenna	MESS-ELEKTRONIK	VULB 9160	3058	2005-11-30	2006-11-29	✓
17	Log-Bicon Antenna	MESS-ELEKTRONIK	VULB 9160	3177	2005-02-07	2007-02-06	
18	Log-Bicon Antenna	MESS-ELEKTRONIK	VULB 9161	4022	2005-08-17	2006-08-16	
19	Test Cable	N/A	10M_OS01	N/A	2005-11-30	2006-11-29	
20	Test Cable	N/A	OS01-1/-2	N/A	2005-11-30	2006-11-29	
21	Test Cable	N/A	10M_OS02	N/A	2005-11-30	2006-11-29	✓
22	Test Cable	N/A	OS02-1/-2/-3	N/A	2005-11-30	2006-11-29	✓
23	RF Switch	Anritsu	MP59B	M65982	2005-11-30	2006-11-29	
24	Pre-Amplifier	Anritsu	MH648A	M09961	2005-11-30	2006-11-29	✓
25	Spectrum Analyzer	ADVAN TEST	R3261C	81720298	2005-09-15	2006-09-14	
26	Spectrum Analyzer	ADVAN TEST	R3132	81700025	2006-02-22	2007-02-21	
27	Spectrum Analyzer	HP	8591EM	3536A00681010	2005-06-30	2006-06-29	
28	EMI Test Receiver	R&S	ESCI	100082	2005-02-02	2007-02-01	
29	EMI Test Receiver	R&S	ESCI	100080	2005-01-10	2007-01-09	
30	Test Receiver	MEB	SMV41	130	2005-11-23	2006-11-22	
31	Test Receiver	PMM	PMM 9000	4310J01002	2006-02-24	2007-02-23	
32	Horn Antenna	EMCO	3115	9605-4803	2005-06-10	2006-06-09	✓
33	Absorbing Clamp	Schwarzbeck	MDS-21	03195	2005-06-17	2006-06-16	✓
34	Voltage Probe	R&S	ESH2-Z3	841.800/023	2005-09-13	2006-09-12	
35	Antenna Mast	Chance Most	CMTB-1.5	N/A	N/A	N/A	
36	Turn Table	Chance Most	CMTB-1.5	N/A	N/A	N/A	
37	Loop Ant	EMCO	6502	00042960	2005-01-14	2008-01-13	

Remark :

(1)" ✓" indicates the instrument used in Test Report.

(2)" N/A" denotes No Model No. / Serial No. and No Calibration specified.

### Diagram - 1

#### Block diagram showing the configuration of system tested

Model No.: SBXD-166LHGE-5

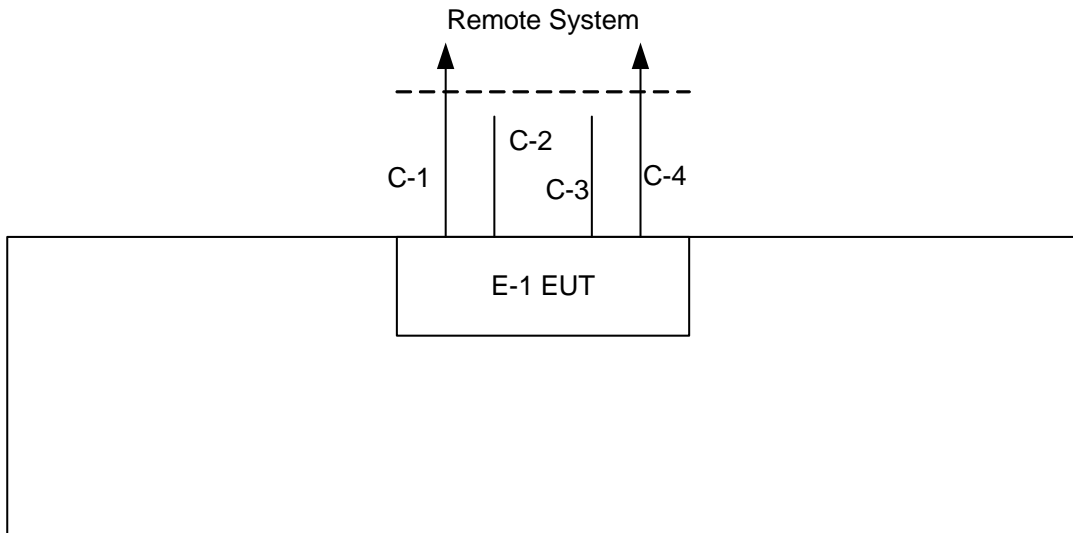

Model No.: SBX-166LHGE-5

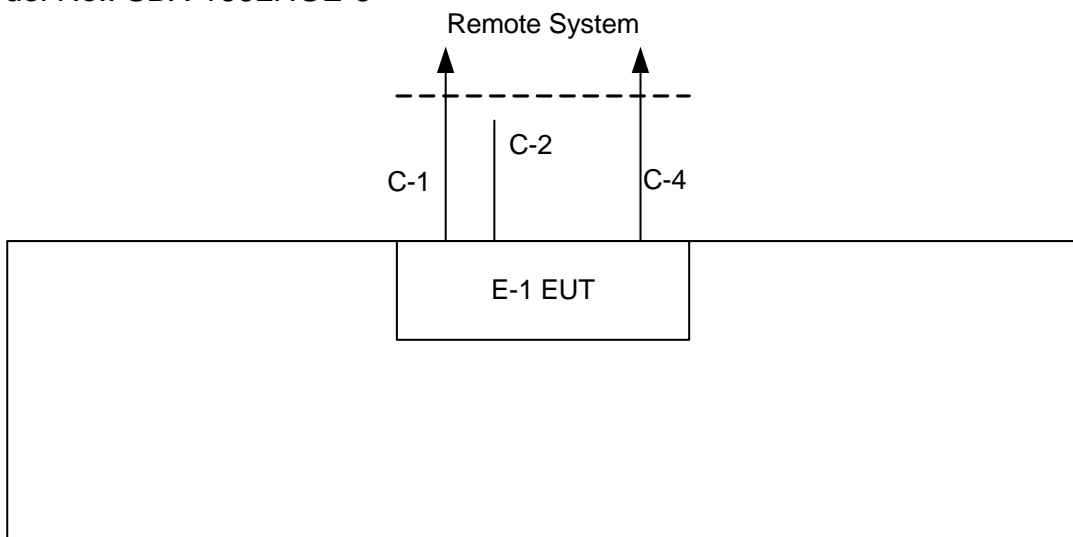

- C-1 RJ-45 Cable X3
- C-2 RJ-45 Cable X2
- C-3 Data Cable X2
- C-4 RJ-11 Cable



## 2.9 EUT Operating Conditions

- (a) Both conducted and radiated testing were performed during the max. EMI emission evaluation.
- (b) The system was configured for testing in a typical fashion (as a customer would normally use it). The EUT was connected to support equipment-remote personal computer. Peripherals of remote PC, such as monitor, keyboard, modem, and printer were contained in this system in order to comply with the CISPR22 Rules requirement. The PC operated in the default 1280 x 1024 VGA Graphic mode. This operating condition was tested and used to collect the included data.
- (c) The EUT exercise program used during radiated and/or conducted emission measurement was designed to exercise the various system components in a manner similar to a typical use. The program contained on a PC hard disk and is auto-starting on power-up. Once loaded, the program sequentially exercises each system component in turn. The sequence used is:  
EUT send/ receive data to/ from remote system.

**3. Justification**

3.1 Limitations

3.1.1 Power Line Conducted Emission (Frequency Range 150KHz-30MHz)

Measurement Frequency Range (MHz)	Mains Terminal Class A Limits (dBuV)		Mains Terminals Class B Limits (dBuV)		Note CISPR FCC Std.
	QP Mode	AV Mode	QP Mode	AV Mode	
	0.15 - 0.50	79.00	66.00	66 - 56 *	
0.50 - 5.00	73.00	60.00	56.00	46.00	CISPR
5.00 - 30.0	73.00	60.00	60.00	50.00	CISPR
0.15 - 0.50	79.00	66.00	66 - 56 *	56 - 46 *	FCC
0.50 - 5.00	73.00	60.00	56.00	46.00	FCC
5.00 - 30.0	73.00	60.00	60.00	50.00	FCC

Notes:

- (1). The tighter limit applies at the band edges.
- (2). The limit of " \* " marked band means the limitation decreases linearly with the logarithm of the frequency in the range.

3.1.2 Radiated Emission Limits (Frequency Range 30MHz-1000MHz)

Measurement Frequency Range (MHz)	Quasi-Peak Mode Class A Limits (dBuV/m)		Quasi-Peak Mode Class B Limits (dBuV/m)		Note CISPR FCC Std.
	10m	30m	10m	3m	
	30.00 -230.00	40.00	30.00	30.00	
230.0 -1000.0	47.00	37.00	37.00	47.00	CISPR
30.00 - 88.00	39.00	N/A	30.00	40.00	FCC
88.00 - 216.0	43.50	N/A	33.50	43.50	FCC
216.0 -960.0	46.00	N/A	36.00	46.00	FCC
above 960.0	49.50	N/A	46.00	54.00	FCC

Notes:

- (1). The tighter limit applies at the band edges.
- (2). Emission level (dBuV/m)=20log Emission level (uV/m).
- (3). A measuring distance of 10m is a primary used. However, either 3m or 10m (instead of 10m) distance may be allowed. If the distance is 3m, add 10dB to the QP-limit above. If the distance is 10m, subtract 10dB from the QP-limit above.

### 3.2 Measurement Justification

#### 3.2.1 Conducted Emission

The initial step in collecting conducted emission data is a spectrum analyzer peak detector mode pre-scanning the measurement frequency range. Significant peaks are then marked and these signals are then Quasi Peak detector mode and Average detector mode re-measured.

Data of **Table - 4.** lists the significant emission frequencies, measured levels, limits and safe margins. All readings are Peak Mode measured unless otherwise stated as QP or AV in column of " Remark ".

If the Peak Mode measured value lower than both QP Mode and AV Mode Limit, EUT shall be deemed to compliance with both QP & AV Limits and then no additional QP Mode or AV Mode measurement performed.

If additional QP or AV Mode measurement needed, and if the QP Mode measured value compliance with the QP Mode Limit and lower than AV Mode Limit, the EUT shall be deemed to meet both QP & AV Limits and then only QP Mode was measured, but AV Mode was not performed ◦

#### 3.2.2 Radiated Emission

The initial step in collecting conducted emission data is a spectrum analyzer peak detector mode pre-scanning the measurement frequency range. Significant peaks are then marked and then Quasi Peak detector mode re-measured.

Data of **Table - 5.** lists the significant emission frequencies, measured levels, limits and safe margins. All readings are Peak Mode measured unless otherwise stated as QP in column of " Remark ".

If the Peak Mode measured value compliance with and lower than Quasi Peak Mode Limit, the EUT shall be deemed to meet QP Limits and then no additional QP Mode measurement performed.

### 3.3 Measurement Data

Table - 4. Conducted Emission Data

Table - 5. Radiated Emission Data

**Table 4 Conducted Emission Data**EUT : Safe@Office/VPN-1 Edge Model/Type No. : SBXD-166LHGE-5Temperature : 24 °C Relative Humidity : 60 % Pressure : 1021 hPa

Special Notes : (EUT Operation Mode or Test Configuration Mode, if applicable)

Mode 2

**Minimum passing margin is -17.93dB at 23.21MHz**

Freq. (MHz)	Terminal L/N	Measured(dBuV)		Limits(dBuV)		Safe Margins (dBuV) Note	
		QP-Mode	AV-Mode	QP-Mode	AV-Mode		
0.15	Line	38.28	*	65.78	55.78	-27.50	(QP)
2.13	Line	26.33	*	56.00	46.00	-29.67	(QP)
5.07	Line	27.47	*	60.00	50.00	-32.53	(QP)
17.71	Line	36.11	*	60.00	50.00	-23.89	(QP)
23.21	Line	42.07	*	60.00	50.00	-17.93	(QP)
26.71	Line	37.31	*	60.00	50.00	-22.69	(QP)
0.16	Neutral	37.28	*	65.46	55.46	-28.18	(QP)
2.17	Neutral	27.52	*	56.00	46.00	-28.48	(QP)
7.46	Neutral	29.03	*	60.00	50.00	-30.97	(QP)
18.29	Neutral	34.97	*	60.00	50.00	-25.03	(QP)
23.18	Neutral	38.72	*	60.00	50.00	-21.28	(QP)
26.57	Neutral	37.34	*	60.00	50.00	-22.66	(QP)

## Remark :

- (1) Reading in which marked as QP means measurements by using are Quasi-Peak Mode with Detector BW=9KHz ; SPA setting in RBW=10KHz,VBW =10KHz, Swp. Time = 0.3 sec./MHz ◦ Reading in which marked as AV means measurements by using are Average Mode with instrument setting in RBW=1MHz,VBW=10Hz, Swp. Time =0.3 sec./MHz ◦
- (2) All readings are QP Mode value unless otherwise stated AVG in column of 『Note』 . If the QP Mode Measured value compliance with the QP Limits and lower than AVG Limits, the EUT shall be deemed to meet both QP & AVG Limits and then only QP Mode was measured, but AVG Mode didn't perform ◦ In this case, a " \* " marked in AVG Mode column of Interference Voltage Measured ◦
- (3) Measuring frequency range from 150KHz to 30MHz ◦



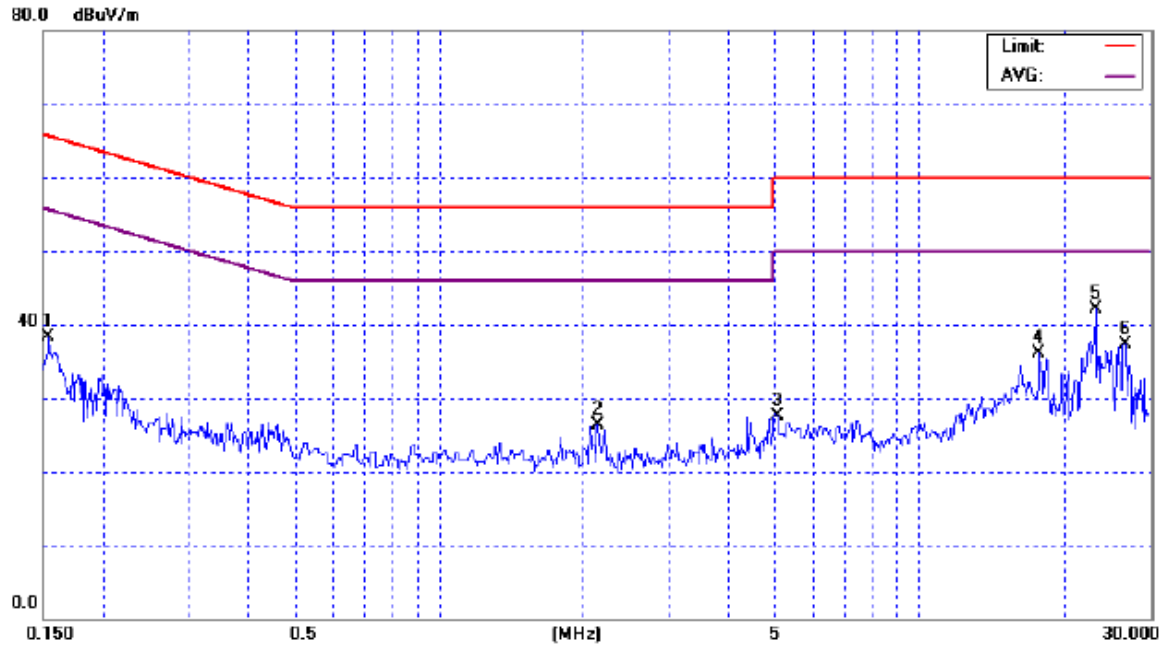

Site SR03

Phase: **L1**

Temperature: 24 °C

Limit: CISPR22 Class B Conduction(QP)

Power: AC 110V/60Hz

Humidity: 60 %

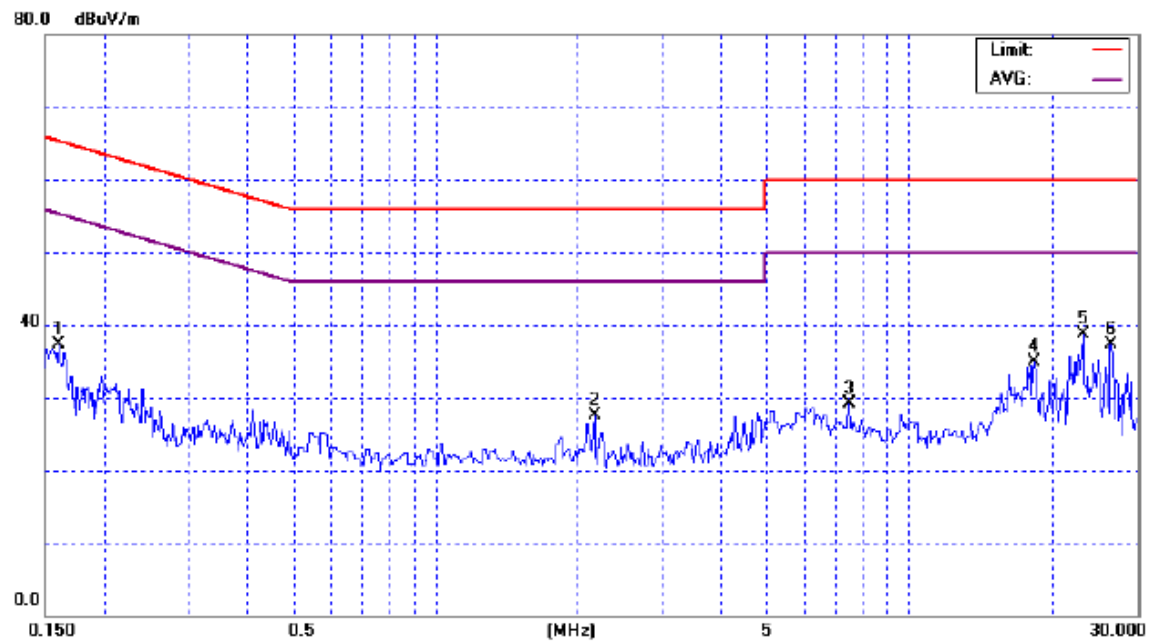

Site SR03

Phase: **N**

Temperature: 24 °C

Limit: CISPR22 Class B Conduction(QP)

Power: AC 110V/60Hz

Humidity: 60 %

**Table 4 Conducted Emission Data**EUT : Safe@Office/VPN-1 Edge Model/Type No. : SBX-166LHGE-5Temperature : 24 °C Relative Humidity : 60 % Pressure : 1021 hPa

Special Notes : (EUT Operation Mode or Test Configuration Mode, if applicable)

Mode 2

**Minimum passing margin is -17.53dB at 23.21MHz**

Freq. (MHz)	Terminal L/N	Measured(dBuV)		Limits(dBuV)		Safe Margins	
		QP-Mode	AV-Mode	QP-Mode	AV-Mode	(dBuV)	Note
0.15	Line	37.88	*	65.97	55.97	-28.09	(QP)
0.28	Line	29.29	*	60.68	50.68	-31.39	(QP)
5.86	Line	27.52	*	60.00	50.00	-32.48	(QP)
18.29	Line	36.94	*	60.00	50.00	-23.06	(QP)
23.21	Line	42.47	*	60.00	50.00	-17.53	(QP)
27.29	Line	37.94	*	60.00	50.00	-22.06	(QP)
0.15	Neutral	36.28	*	65.94	55.94	-29.66	(QP)
6.04	Neutral	29.13	*	60.00	50.00	-30.87	(QP)
9.54	Neutral	28.43	*	60.00	50.00	-31.57	(QP)
18.29	Neutral	39.37	*	60.00	50.00	-20.63	(QP)
23.21	Neutral	39.52	*	60.00	50.00	-20.48	(QP)
26.57	Neutral	36.94	*	60.00	50.00	-23.06	(QP)

## Remark :

- (1) Reading in which marked as QP means measurements by using are Quasi-Peak Mode with Detector BW=9KHz ; SPA setting in RBW=10KHz,VBW =10KHz, Swp. Time = 0.3 sec./MHz ◦ Reading in which marked as AV means measurements by using are Average Mode with instrument setting in RBW=1MHz,VBW=10Hz, Swp. Time =0.3 sec./MHz ◦
- (2) All readings are QP Mode value unless otherwise stated AVG in column of 『Note』 . If the QP Mode Measured value compliance with the QP Limits and lower than AVG Limits, the EUT shall be deemed to meet both QP & AVG Limits and then only QP Mode was measured, but AVG Mode didn't perform ◦ In this case, a " \* " marked in AVG Mode column of Interference Voltage Measured ◦
- (3) Measuring frequency range from 150KHz to 30MHz ◦

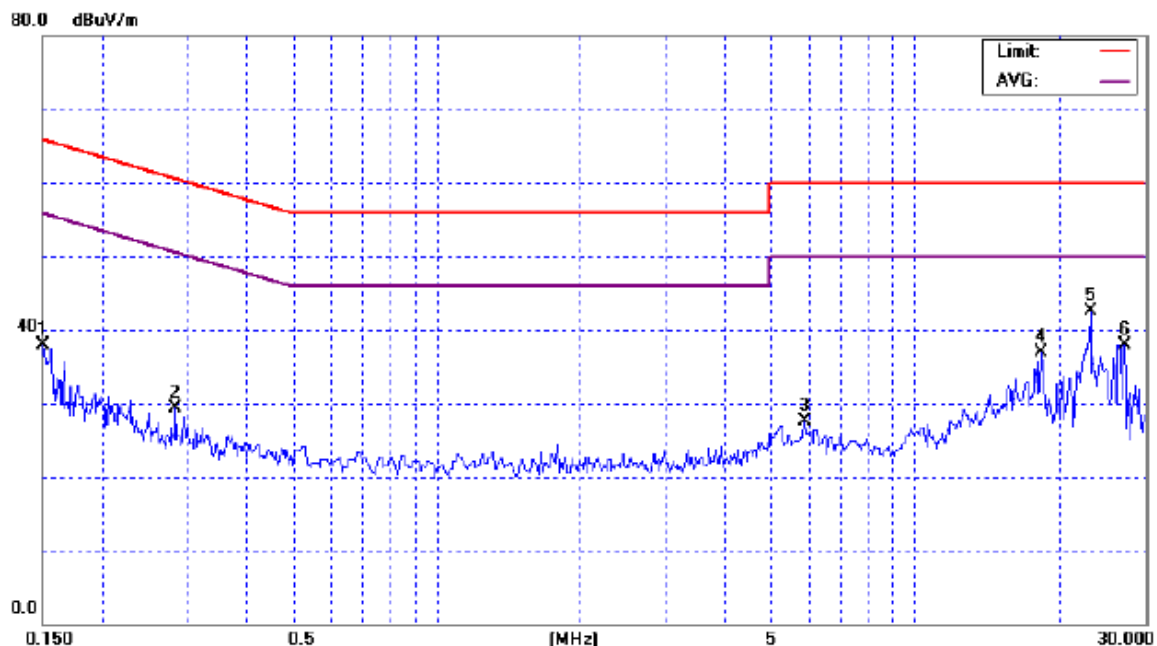

Site SR03

Phase: **L1**

Temperature: 24 °C

Limit: CISPR22 Class B Conduction(QP)

Power: AC 110V/60Hz

Humidity: 60 %

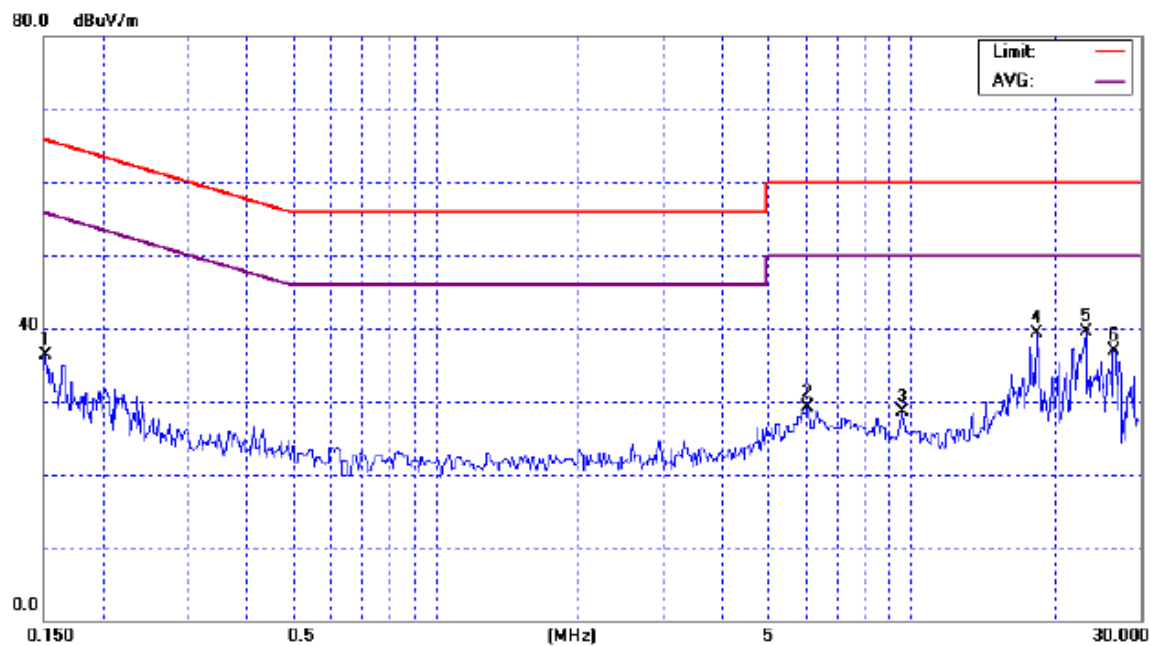

Site SR03

Phase: **N**

Temperature: 24 °C

Limit: CISPR22 Class B Conduction(QP)

Power: AC 110V/60Hz

Humidity: 60 %

Table 5 Radiated Emission Data

EUT : Safe@Office/VPN-1 Edge Model/Type No. : SBXD-166LHGE-5

Temperature : 18 °C Relative Humidity : 80 % Pressure : 1032 hPa

Special Notes : (EUT Operation Mode or Test Configuration Mode, if applicable)

Mode 2

**Minimum passing margin is -3.16dB at 875.00MHz**

Freq. (MHz)	Ant. H/V	Reading(RA) (dBuV)	Corr.Factor(CF) (dB)	Measured(FS) (dBuV/m)	Limits(QP) (dBuV/m)	Safe Margins (dBuV/m)	Note
33.45	H	41.23	- 18.47	22.76	30.00	- 7.24	QP
34.03	V	40.23	- 18.40	21.83	30.00	- 8.17	QP
55.40	V	42.00	- 17.61	24.39	30.00	- 5.61	QP
55.52	H	39.41	- 17.62	21.79	30.00	- 8.21	QP
65.42	V	41.15	- 18.22	22.93	30.00	- 7.07	QP
365.41	H	40.03	- 13.59	26.44	37.00	- 10.56	QP
624.99	V	36.41	- 7.53	28.88	37.00	- 8.12	QP
800.03	H	37.23	- 4.41	32.82	37.00	- 4.18	QP
800.21	V	36.03	- 4.41	31.62	37.00	- 5.38	QP
875.00	V	36.41	- 3.58	32.83	37.00	- 4.17	QP
875.00	H	37.42	- 3.58	33.84	37.00	- 3.16	QP
900.12	V	34.73	- 3.20	31.53	37.00	- 5.47	QP
993.28	H	30.76	- 1.51	29.25	37.00	- 7.75	QP

Remark :

- (1) Reading in which marked as QP or Peak means measurements by using are Quasi-Peak Mode or Peak Mode with Detector BW=120KHz ; SPA setting in RBW=120KHz, VBW =120KHz, Swp. Time = 0.3 sec./MHz ◦
- (2) All readings are Peak unless otherwise stated QP in column of 『Note』 . Peak denotes that the Peak reading compliance with the QP Limits and then QP Mode measurement didn't perform ◦
- (3) Measuring frequency range from 30MHz to 1000MHz ◦
- (4) If the peak scan value lower limit more than 20dB, then this signal data does not how in table ◦

Vertical

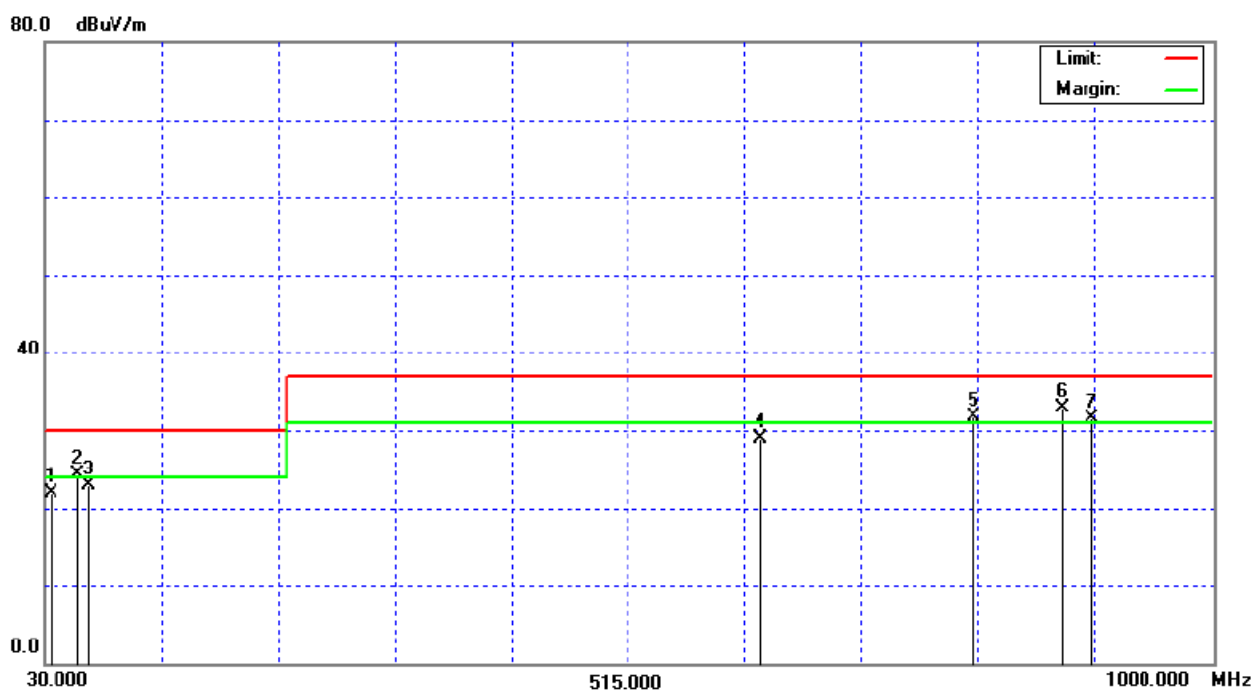

Horizontal

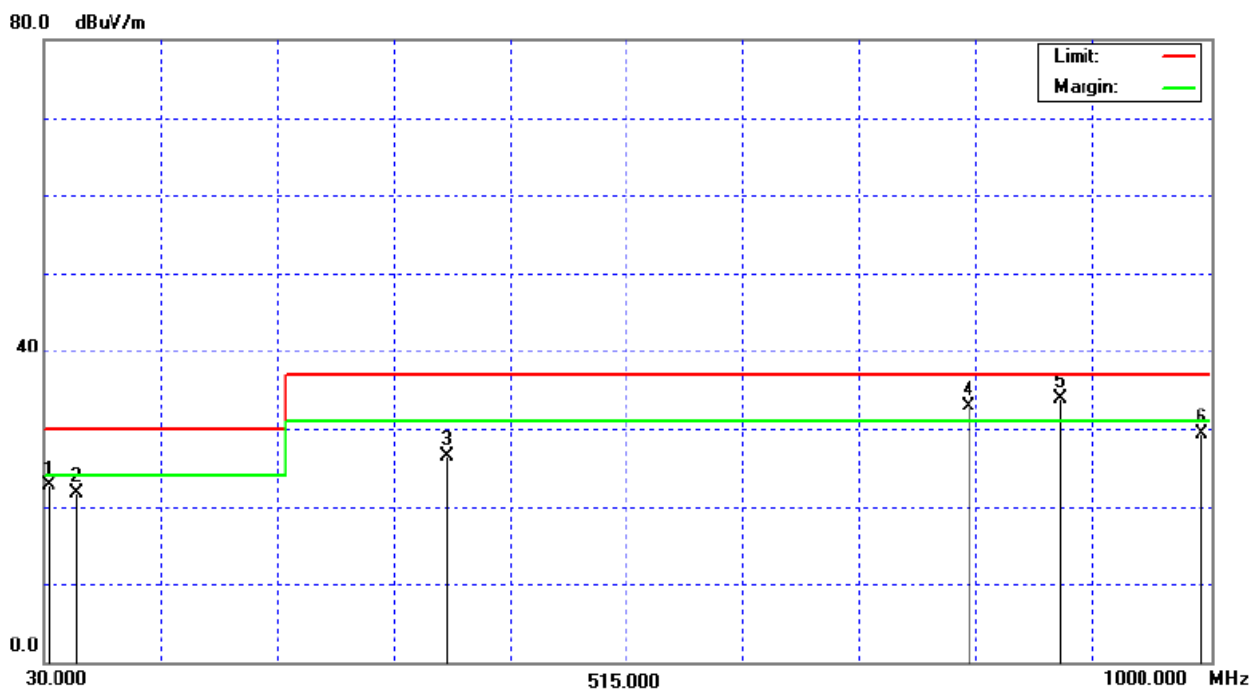

Table 5 Radiated Emission Data

EUT : Safe@Office/VPN-1 Edge Model/Type No. : SBX-166LHGE-5  
 Temperature : 23 °C Relative Humidity : 54 % Pressure : 1020 hPa  
 Special Notes : (EUT Operation Mode or Test Configuration Mode, if applicable)

Mode 2

**Minimum passing margin is -3.06dB at 875.40MHz**

Freq. (MHz)	Ant. H/V	Reading(RA) (dBuV)	Corr.Factor(CF) (dB)	Measured(FS) (dBuV/m)	Limits(QP) (dBuV/m)	Safe Margins (dBuV/m)	Note
30.34	H	43.20	- 18.81	24.39	30.00	- 5.61	(QP)
43.15	V	37.87	- 17.66	20.21	30.00	- 9.79	(QP)
55.78	H	41.77	- 17.62	24.15	30.00	- 5.85	(QP)
58.03	V	44.03	- 17.67	26.36	30.00	- 3.64	(QP)
66.02	V	43.86	- 18.27	25.59	30.00	- 4.41	(QP)
250.03	V	45.11	- 16.58	28.53	37.00	- 8.47	(QP)
250.20	H	44.64	- 16.57	28.07	37.00	- 8.93	(QP)
799.89	V	34.57	- 4.41	30.16	37.00	- 6.84	(QP)
800.10	H	35.23	- 4.41	30.82	37.00	- 6.18	(QP)
874.89	V	36.88	- 3.58	33.30	37.00	- 3.70	(QP)
875.40	H	37.52	- 3.58	33.94	37.00	- 3.06	(QP)
999.98	H	32.76	- 1.41	31.35	37.00	- 5.65	(QP)

Remark :

- (1) Reading in which marked as QP or Peak means measurements by using are Quasi-Peak Mode or Peak Mode with Detector BW=120KHz ; SPA setting in RBW=120KHz, VBW =120KHz, Swp. Time = 0.3 sec./MHz ◦
- (2) All readings are Peak unless otherwise stated QP in column of 『Note』 . Peak denotes that the Peak reading compliance with the QP Limits and then QP Mode measurement didn't perform ◦
- (3) Measuring frequency range from 30MHz to 1000MHz ◦
- (4) If the peak scan value lower limit more than 20dB, then this signal data does not how in table ◦

### Vertical

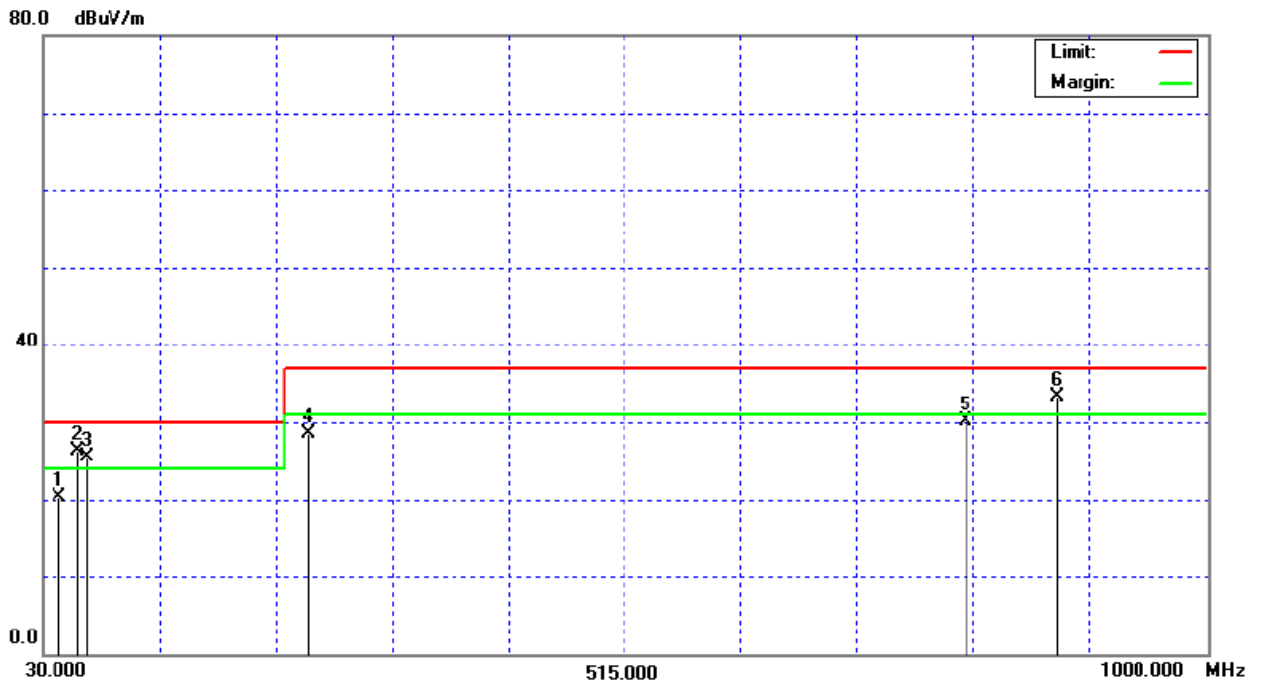

### Horizontal

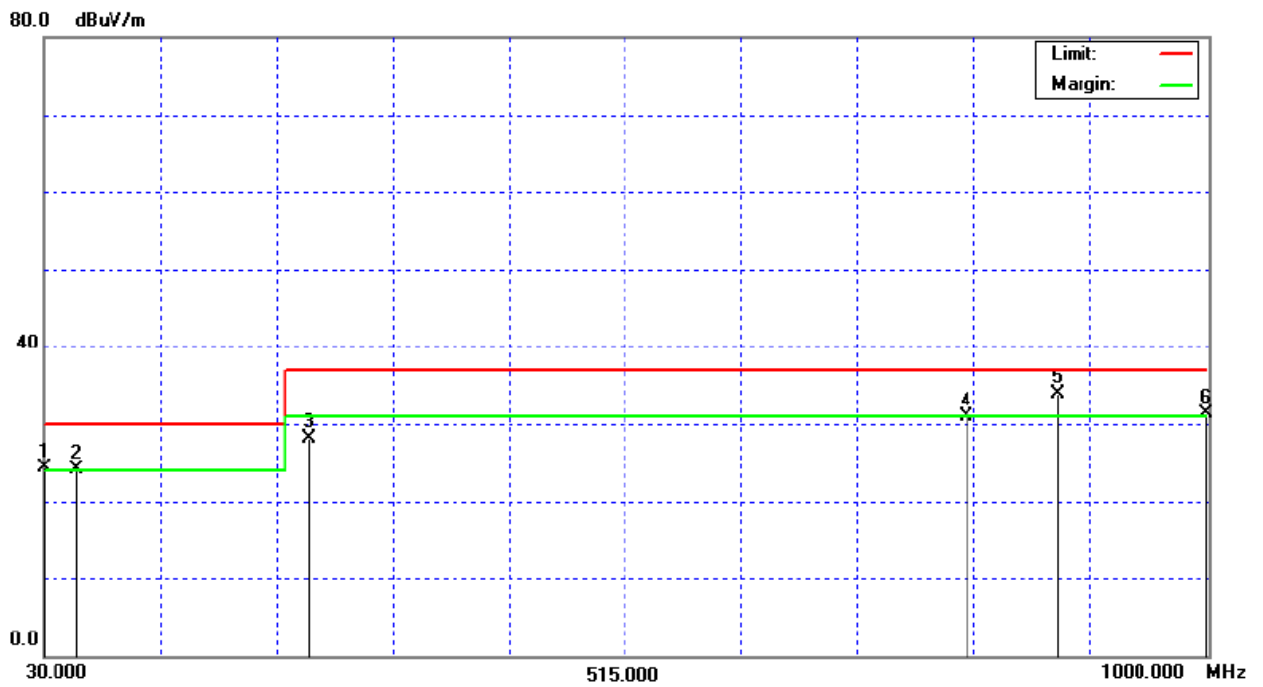

# Attachment

## Table Contents

- A. EUT Test Photos
- B. Product Labeling