

ALIEN TECHNOLOGY®

HARDWARE SETUP GUIDE

8001467-000 Revision B



ALIEN®

ALR-9640

Legal Notices

Copyright © 2004 Alien Technology Corporation. All rights reserved.

Alien Technology Corporation has intellectual property rights relating to technology embodied in the products described in this document, including without limitation certain patents or patent pending applications in the U.S. or other countries.

This document and the products to which it pertains are distributed under licenses restricting their use, copying, distribution and decompilation. No part of this product documentation may be reproduced in any form or by any means without the prior written consent of Alien Technology Corporation and its licensors, if any. Third party software is copyrighted and licensed from Licensors. Alien, Alien Technology, the Alien logo, Nanoblock, Fluidic Self Assembly, FSA, Alien RFID Gateway, Gen2Ready, Nanoscanner and other graphics, logos, and service names used in this document are trademarks of Alien Technology Corporation in the U.S. and other countries. All other trademarks are the property of their respective owners. U.S. Government approval required when exporting the product described in this documentation.

Federal Acquisitions: Commercial Software -- Government Users Subject to Standard License Terms and Conditions. U.S. Government: If this Software is being acquired by or on behalf of the U.S. Government or by a U.S. Government prime contractor or subcontractor (at any tier), then the Government's rights in the Software and accompanying documentation shall be only as set forth in this license; this is in accordance with 48 C.F.R. 227.7201 through 227.7202-4 (for Department of Defense (DoD) acquisitions) and with 48 C.F.R. 2.101 and 12.212 (for non-DoD acquisitions).

DOCUMENTATION IS PROVIDED "AS IS" AND ALL EXPRESS OR IMPLIED CONDITIONS, REPRESENTATIONS AND WARRANTIES, INCLUDING ANY IMPLIED WARRANTY OF MERCHANTABILITY, FITNESS FOR A PARTICULAR PURPOSE OR NON-INFRINGEMENT ARE HEREBY DISCLAIMED, EXCEPT TO THE EXTENT THAT SUCH DISCLAIMERS ARE HELD TO BE LEGALLY INVALID.

FCC Compliance

This equipment has been tested and found to comply with the limits for Class A digital device, pursuant to Part 15 of the FCC Rules. These limits are designed to provide reasonable protection against harmful interference when the equipment is operated in a commercial environment. This equipment generates, uses and can radiate radio frequency energy and, if not installed and used in accordance with instruction manual, may cause harmful interference with radio communications. Operation of this equipment in a residential area is likely to cause harmful interference in which case the user will be required to correct the interference at his own expense.

Any change or modification to this product voids the user's authority to operate per FCC Part 15 Subpart A. Section 15.21 regulations.

Industry Canada Compliance

Operation is subject to the following two conditions: (1) this device may not cause interference and (2) this device must accept any interference, including interference that may cause undesired operation of the device. This device has been designed to operate with an antenna having a maximum gain of 6dBi. Antenna having a higher gain is strictly prohibited per regulations of Industry Canada. The required antenna impedance is 50 ohms. To reduce potential radio interference to other users, the antenna type and its gain should be so chosen that the equivalent isotropically radiated power (EIRP) is not more than that required for successful communication.

Caution

To meet FCC and Industry Canada RF Exposure guidelines the reader antennas shall be positioned so that personnel in the area for prolonged periods may safely remain at least 23 cm (9 in) in an uncontrolled environment from the antenna's surface. See FCC OET Bulletin 56 "Hazards of radio frequency and electromagnetic fields" and Bulletin 65 "Human exposure to radio frequency electromagnetic fields. The antennas shall not be co-located with other transmitting devices.

Alien Technology®

Hardware Setup Guide

ALR-9640

8001467-000 Revision A



Table of Contents

CHAPTER 1 INTRODUCTION	1
Audience	1
RFID Reader Overview	1
Class 1 NanoBlock Tags.....	2
Requirements.....	2
Specifications	3
RFID Reader.....	3
Mechanical.....	4
RS-232 Port Pinouts	5
RS232 Connector (Female) – Looking at Reader	5
IO Port Connector Pinouts.....	5
I/O Port Connector (Male) – Looking at Reader	5
Reader Schematics	6
CHAPTER 2 READER HARDWARE INSTALLATION AND OPERATION	7
Receiving the RFID Reader	7
Reader I/O Panel.....	8
Diagnostic LEDs	8
Diagnostic LEDs	8
System Assembly and Bench Test	9
Bench Test Configuration	10
Bench Test Procedure.....	11
Installation	12
Requirements	12
Hardware Installation Procedure	13
System Operation: Software Control	14
Reader Interface Guide	14
Demonstration Software Guide	14

(This page intentionally left blank)

CHAPTER 1

Introduction

This *Hardware Setup Guide* provides instructions for installing and operating the ALR-9640 readers.

This document is designed for use by RFID system integrators and software developer - those who wish to develop software products and extended systems that take full advantage of the RFID Reader's capabilities.

For an overview of RFID technology and a glossary of terms, please refer to the *RFID Primer* included with your RFID Reader Developer's Kit.

For an overview of the communication interfaces to the Readers, please refer to the *Reader Interface Guide* included with your RFID Reader Developer's Kit.

Audience

For the purposes of this document, we assume the readers of the *Hardware Setup Guide*:

- are competent PC users
- have minimal previous knowledge of radio-frequency identification technology
- are experienced in software development and/or hardware systems integration

RFID Reader Overview

The Alien RFID reader is designed to read and program Class I NanoBlock tags (see below) and issue event reports to a host computer system. The host computer can be locally connected to the reader via RS-232, or at a remote network location.

The RFID Reader is delivered with the following components and accessories:

- One ARL-9640 RFID Reader
- One RS-232 serial cable (for host computer)
- One power supply
- Documentation on CD-ROM

Class 1 NanoBlock Tags

The ALR-9640 RFID readers are designed to read and program Alien's Class 1 RFID Tags.

These tags comply with the MIT AutoID Center's open specification for RFID.

Class I tags are "passive" devices. That is, they do not have an onboard power source. They are powered by the RF energy transmitted by the reader.

They communicate with the Reader by means of "Backscatter Modulation". That is, they do not actually transmit anything; they merely change their reflective characteristics in a systematic way and reflect RF energy back to the reader. An analogy to this is the way you can use a mirror to transmit information by reflecting light from the Sun.

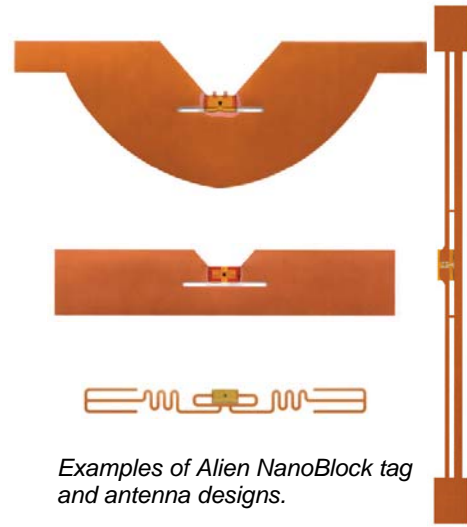

Requirements

To interface with the RFID Reader you will need the following:

- a PC running Windows 98 or higher, with CD-ROM drive and an available RS-232 serial port
- standard 120 VAC power
- host software (Alien demo software or your own custom software)
- RFID Tags (AIDC Class 1 compliant)
- standard power cord (desired length) with grounded, 3-pronged plugs

Specifications

Specifications for key components of the ARL-9640 RFID Reader system are provided in the tables below:

RFID Reader

Name	Alien RFID Reader
Part Number	ALR-9640
Architecture	Point-to-multipoint reader network
Frequency	902.8 MHz – 927.6 MHz
Hopping Channels	63
Channel Spacing	400 KHz
Channel Dwell Time	< 0.4 Seconds
RF Transmitter	< 30 dBm
Antenna	Dual switching 6dBi Linear Antenna
Modulation Method	On Off Keying (OOK)
20 db Modulation Bandwidth	< 400 KHz
RF Receiver	2 Channels
Power Consumption	25 Watts (120 VAC at 500 mW)
Communications Interface	RS-232, LAN TCP/IP
Inputs/Outputs	4 logic I/O, com port, LAN, power
Dimensions	(L) 11.45in (29 cm) x (W) 8.50 in (21 cm) x (D) 1.45 in (3.68 cm)
Weight	Approximately 1.8 lb (0.82 Kg)
Operating Temperature	+32 °F to +122°F (0°C to +50°C)

Mechanical

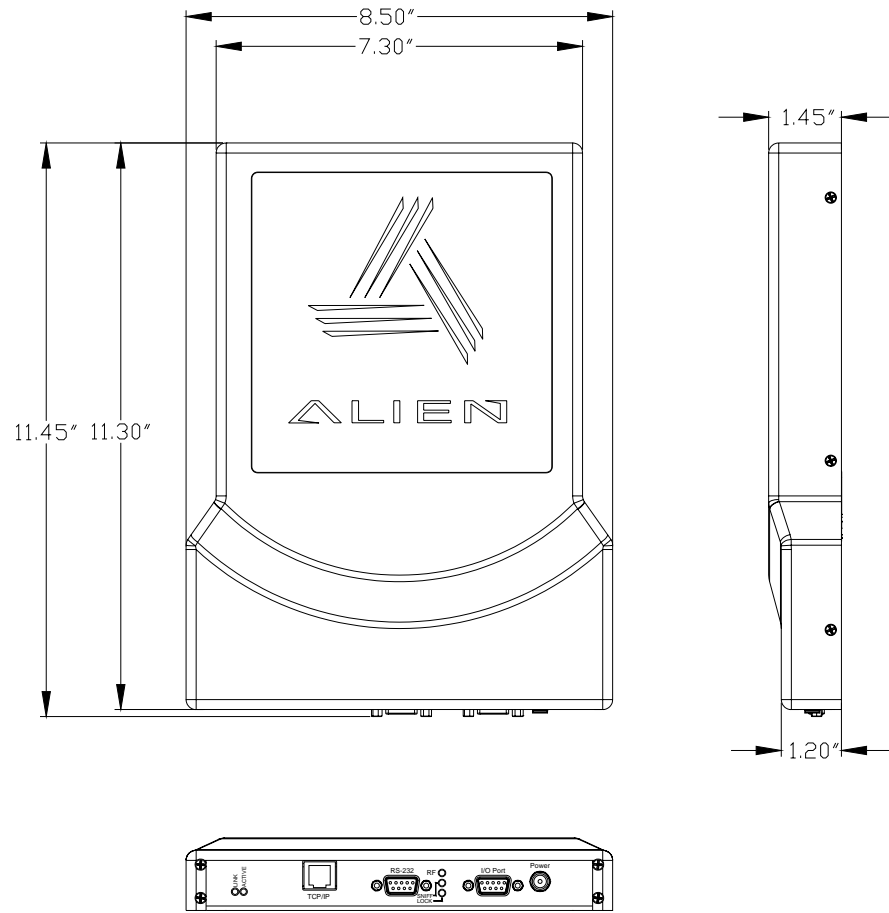

Tolerance: xx = ± 0.10"

Figure 1 - Outline Drawing of the ALR-9640

RS-232 Port Pinouts

RS-232 Connector (Female DB-9F)	
Pin 1	DCD Connected to Pin 6
Pin 2	TR1 Transmit Data (Output)
Pin 3	RC1 Receive Data (Input)
Pin 4	DTR Connected to Pin 6
Pin 5	Ground
Pin 6	DSR Connected to Pin 4
Pin 7	RTS Connected to Pin 8
Pin 8	CTS Connected to Pin 7
Pin 9	Not Connected

RS232 CONNECTOR (FEMALE) – LOOKING AT READER

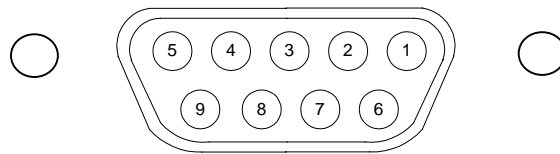

IO Port Connector Pinouts

I/O Port Connector (Male DB-9M)	
Pin 1	Output 0
Pin 2	Output 2
Pin 3	Input 0
Pin 4	Input 2
Pin 5	Ground
Pin 6	Output 1
Pin 7	Output 3
Pin 8	Input 1
Pin 9	Input 3

I/O PORT CONNECTOR (MALE) – LOOKING AT READER

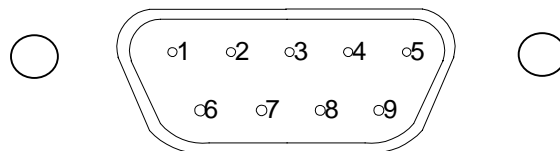

Reader Block Diagram

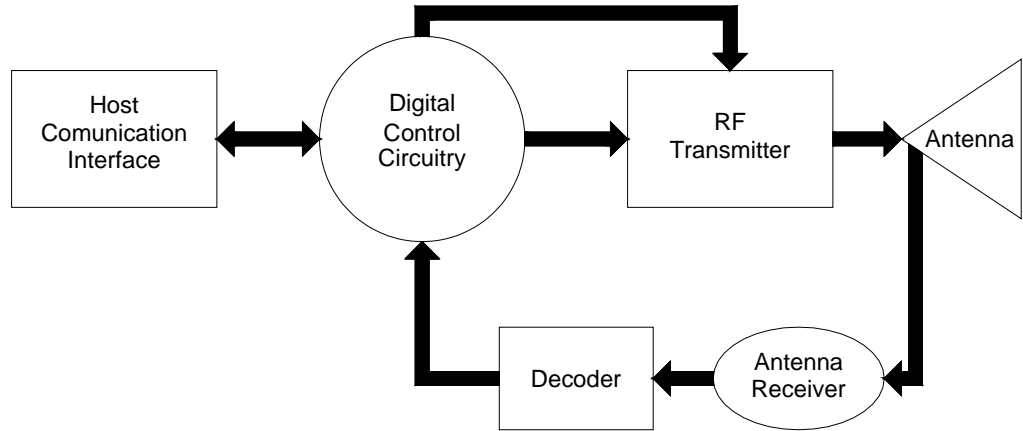

Figure 2 - System Architecture for the ALR-9640 Reader

CHAPTER 2

Reader Hardware Installation and Operation

This chapter describes the RFID Reader and provides installation and operation information.

Receiving the RFID Reader

Your RFID Reader Developer's Kit is shipped with the items listed below. Please verify the contents of your received shipment before assembling.

- RFID Reader with integrated antennas
- RS-232 reader-to-PC cable
- Reader power supply and cables.
- CD-ROM containing demonstration software, user guides and documentation

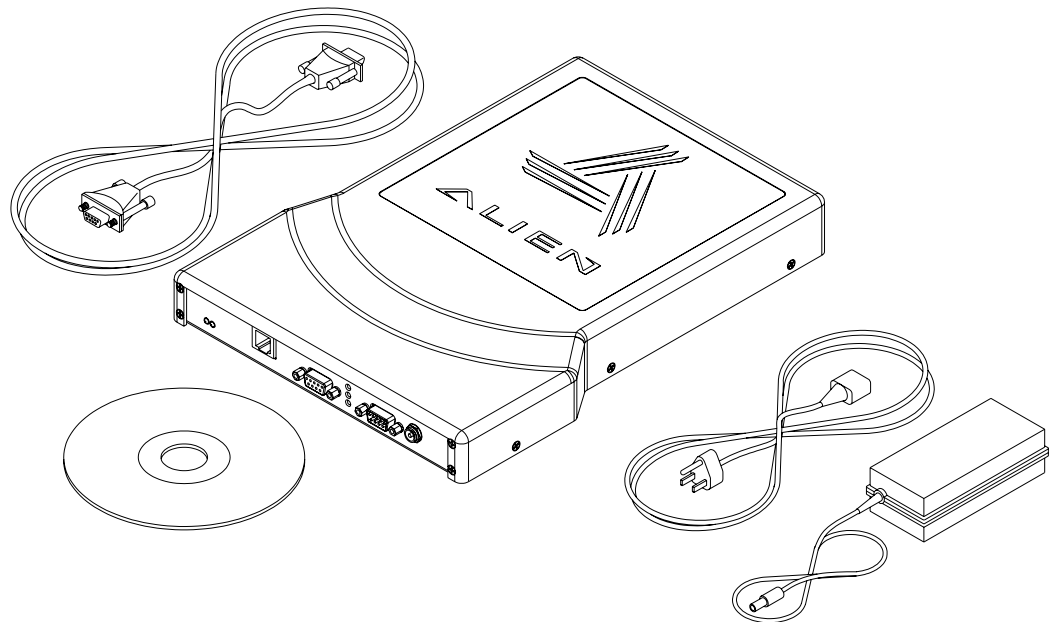

Figure 3 - ALR-9640

Reader I/O Panel

The I/O panel (shown below) houses the following:

- Power connector
- 9-pin D male I/O connector
- 3 Diagnostic LEDs (RF Power, Sniff and Lock)
- 9-pin D female RS-232 serial port
- LAN TCP/IP port
- network activity LEDs

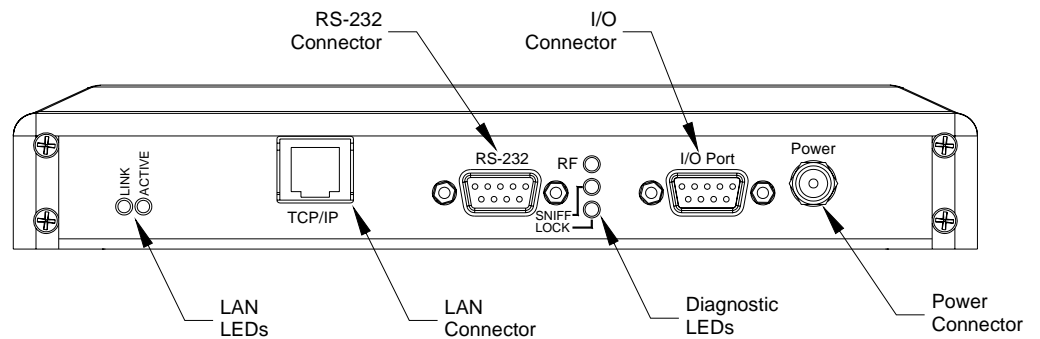

Figure 4 - Reader Connections and LEDs

Diagnostic LEDs

The diagnostic LEDs provide external indication of various conditions:

- **RF On (red)** - indicates that RF is being emitted by the reader
- **Sniff (yellow)** - indicates a tag signal has been detected, though it may not yet be strong enough to complete a transaction
- **Lock (green)** - indicates a tag has been read

System Assembly and Bench Test

Assembling the RFID Reader system is easy. We recommend you set up the system and verify its operation in a bench test configuration (shown below) before installing it in a production setting.

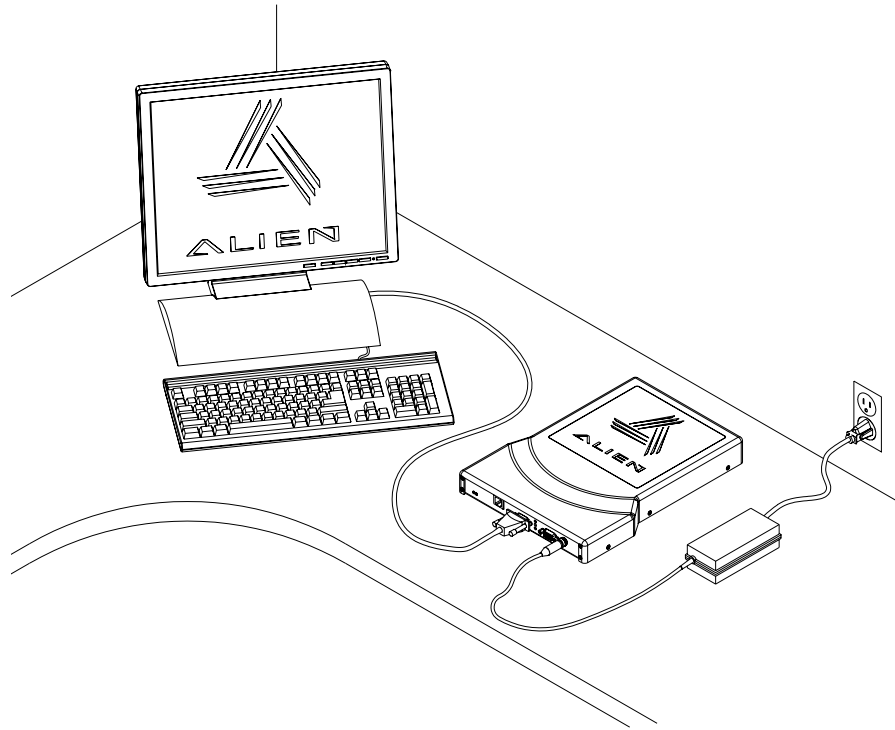

Figure 6 - Typical Bench Test Setup

CAUTION: To meet FCC and Industry Canada RF Exposure guidelines the reader antennas shall be positioned so that personnel in the area for prolonged periods may safely remain at least 23 cm (9 in) in an uncontrolled environment from the antenna's surface. See FCC OET Bulletin 56 "Hazards of radio frequency and electromagnetic fields" and Bulletin 65 "Human exposure to radio frequency electromagnetic fields. The antennas shall not be co-located with other transmitting devices.

Bench Test Configuration

1. Situate the Reader on a tabletop. Ensure the following conditions:

- Two standard 120 VAC outlets are available nearby (one for the reader, one for the PC if needed).

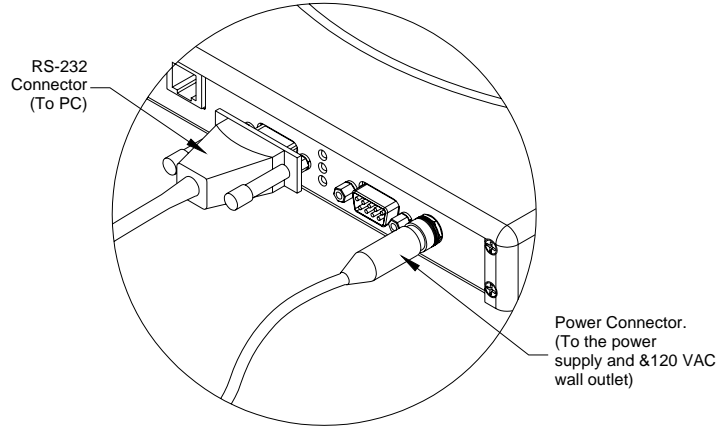

Figure 7 - RS-232 and Power Connections

- Sufficient space is available on the tabletop for the PC, reader and antenna.

2. Connect the RS-232 cable to the reader.

- Align the male cable connector so that its shape and pins match the shape and holes of the female DB-9 RS-232 port.

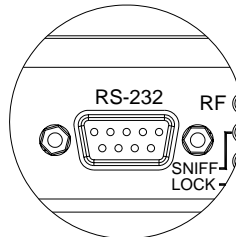

Figure 8 - RS-232 Connector

- Push the aligned connector into the port.
- Finger-tighten the screws to secure the cable/connector to the reader.

3. Connect the RS-232 cable to the serial port on the PC.

4. Connect the power supply to the reader.

- Using the thin cable attached to power supply, push the connector into the port until it is securely seated. Do not plug the power supply into the wall outlet yet.

5. **Plug power cord into power supply.**
 - Use the female end of a standard 3-pronged power cord.
6. **Plug the power supply cable into the wall outlet and verify power.**
 - The LEDs will illuminate when power is on.
7. **Plug in the PC (if necessary) and turn it on.**
8. **Launch the desired host software application.**
 - You may use Alien's demo system software or custom software developed per the reader-host protocol for your specific application.

You are now ready to bench test or demonstrate the RFID Reader system.

Bench Test Procedure

1. **Access an operational mode suitable for bench testing.**
 - Select a mode that will allow multiple consecutive reads of a single tag.
 - Refer to the applicable software application user guide for specific instructions.
2. **Position the reader to you can see the LEDs.**
 - You may also want to position the PC so you can view the monitor simultaneously for later tests.
3. **Move a tag slowly into the antenna's range.**
 - Begin with the tag well outside the expected range (~15-20 ft) and move it toward the antenna while observing the LEDs.
4. **Verify the Lock LED illuminates when the tag is inside the read window.**
 - Lock is the green LED.
5. **Verify the host receives the tag data.**
 - Refer to indications specified in applicable user guide to verify the tag was read successfully.
6. **If bench test conditions are verified, proceed to installation.**

NOTE: To perform a hard reboot of the system, simply cycle power on the reader.

Installation

This section provides guidance for configuring components in your RFID system. You should consider the overall design of your specific system before permanently mounting the equipment.

Installation involves all the same connection steps required for bench test. However, instead of situating equipment on a tabletop, the reader and its accessories are mounted in your application environment.

Requirements

Before installing your RFID Reader system, you will need the following:

- a PC running Windows 98 or higher, with CD-ROM drive (for demo system software) and one available RS-232 serial port
- standard 120 VAC power for the reader and PC
- host software
- additional RS-232 cables or antenna coax cables needed to accommodate routing requirements
- standard grounded, three-pronged power cord of desired length
- mounting hardware suitable for the surface to which equipment is to be attached (e.g., wood screws, moly-bolts, brackets, etc.)

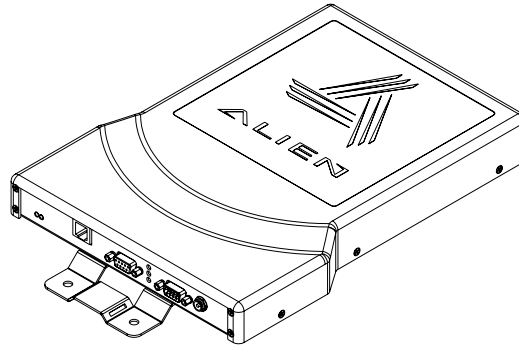

Figure 9 - View of the Reader showing optional mounting kit 0500126-001

Hardware Installation Procedure

1. Select mounting position for ALR-9640

CAUTION: To meet FCC and Industry Canada RF Exposure guidelines the reader antennas shall be positioned so that personnel in the area for prolonged periods may safely remain at least 23 cm (9 in) in an uncontrolled environment from the antenna's surface. See FCC OET Bulletin 56 "Hazards of radio frequency and electromagnetic fields" and Bulletin 65 "Human exposure to radio frequency electromagnetic fields. The antennas shall not be co-located with other transmitting devices.

- Mount the ARL-9640 at the periphery of the desired read window (either overhead or at the side), so that the position of the most distant tag passing through the window is no farther from the antenna than the maximum range specified for your system design.
- Position the ARL-9640 at a height approximately midway between the highest and lowest expected tag position. (For example, a pallet tag may be the lowest tag position to be read, while the top-most case on a fully stacked pallet may represent your highest tag position.)
- Be sure power is available at the selected reader location.

2. Select location for host PC.

- Situate the host PC within 50 ft of the reader in a safe location away from vehicular and foot traffic.

3. Connect reader power.

- Push the power supply connector into the reader port.
- Plug the female end of the power cord into the power supply.
- Plug the male end of the power cord into the 120 VAC outlet.

4. Connect reader to host PC.

- Align the RS-232 connector with the corresponding serial port on the reader and push the connector onto the pins. Finger-tighten the screws to secure the cable to the reader.
- Align and connect the other end of the RS-232 with the serial port on the PC.

5. Connect power to the PC.

System Operation: Software Control

ARL-9640 is controlled from software running on a host system that communicates with the reader using a text-based protocol. All applications use this protocol to communicate with the reader.

You may operate the ARL-9640 from your own application code using this interface, use the example code provided on the CD or use the Alien RFID Gateway application - a demonstration program also included on the CD.

For details, refer to either the *Reader Interface Guide* or the *Demonstration Software Guide* described briefly below.

Reader Interface Guide

The text-based interface mentioned above is described in detail in the *Reader Interface Guide*. Using this interface, the reader can be configured to read tags when queried or after one of a variety of event triggers (e.g., a rising edge on one of the I/O pins, or a timer).

Tag data acquired in response to these triggers can be transmitted to the host in a number of formats (e.g., terse, text, XML or custom) and under a number of conditions (e.g., on a new tag being observed, or a tag disappearing from view).

If you are a software developer, the *Reader Interface Guide* provides the information you will need to connect to the reader from a host computer, communicate with it, and customize its performance.

Demonstration Software Guide

The *Demonstration Software Guide* describes the installation and operation of the Alien RFID Gateway Application.

The Alien RFID Gateway Application is a useful demonstration program that allows users to explore the reader's functionality and build customizable demos with a user-friendly interface.

Using the Gateway, the various operating modes of the reader can be controlled and custom interactive demos can be constructed using sounds, images, and text.