

# FCC ID TEST REPORT

According to

**FCC Part 15 Subpart C, Intentional Radiators**

**EUT Type PRESENTER**

**Transmitter (TX) 1) Model No.: PRESENTER**

**2) FCC ID: P5A002**

**Applicant Name: ARESON TECHNOLOGY CORP.**

**Address See the General Information for details.**

Test Date : 2004/12/15

Issued Date : JAN. 21, 2005

Test Engineer : HADES HUANG

NVLAP Signature : Peter Kao

Peter Kao / Director

- The test report shall not be reproduced except in full, without the written approval of the "PEP"
- The report must not be used by the client to claim product endorsement by NVLAP or any agency of the United States government.
- This report is applicable only for EUT Model which described in page 4 .
- The testing result in this report are traceable to national or international standard .

**PEP TESTING LABORATORY**

*12-3Fl, No. 27-1, Lane 169, Kang-Ning St., Hsi-Chih,*

*Taipei Hsien, Taiwan, R. O. C.*

*Tel : 886-2-26922097 Fax : 886-2-26956236*

## Table of Contents

1.	GENERAL INFORMATION	3
2.	PRODUCT INFORMATION	4
3.	EUT DESCRIPTION AND TEST METHODS	5
4.	MODIFICATION(S)	6
5.	TEST SOFTWARE USED	6
6.	SUPPORT EQUIPMENT USED	7
7.	DESCRIPTION FIELD STRENGTH OF FUNDAMENTAL AND HARMONICS TEST	8
8.	DESCRIPTION OF CONDUCTED EMISSIONS TEST	10
9.	DESCRIPTION OF RADIATED EMISSIONS TEST	11
10.	FIELD STRENGTH OF FUNDAMENTAL AND HARMONICS TEST SETUP PHOTOS	14
11.	FIELD STRENGTH OF FUNDAMENTAL AND HARMONICS TEST DATA	15
12.	CONDUCTED EMISSIONS TEST SETUP PHOTOS	16
13.	CONDUCTED EMISSIONS TEST DATA	16
14.	RADIATED EMISSIONS TEST SETUP PHOTOS	17
15.	RADIATED EMISSIONS TEST DATA	18
16.	LIST OF MEASURED INSTRUMENTS	20
17.	FCC ID LABEL SAMPLE	21
18.	INFORMATION TO THE USER	22
19.	EUT EXTERNAL PHOTOS	23
20.	EUT INTERNAL PHOTOS	24

## 1. General Information

Measurement of electromagnetic emissions (EME) of radio frequency devices including intentional and/or unintentional radiators for compliance with the technical rules and regulations of the Federal Communications Commission under FCC Part 2 and 15.

**Applicant Name/Address: ARESON TECHNOLOGY CORP.**

**12F, NO. 111-6, HSING-DE RD., SAN CHUNG, TAIPEI  
HSIEN, TAIWAN, R. O. C.**

**Contact Person: ERIC CHUNG / SENIOR MANAGER**

**Phone No.: 886-2-29954995 Fax No.: 886-2-29954990**

**Manufacturer Name/Address: ARESTECH INT'L CORP. (CHINA)  
SHA-WU, TANG-XIA, DONG-GUAN, GUAN-DONG,  
CHINA**

◇ Regulation: FCC Part 2 and 15

◇ Limitation: Part 15, Section 15.249, 15.207 and 15.209

◇ Test Procedure: ANSI C63.4-1992

◇ Place of Test: PEP Testing Laboratory

12-3Fl, No. 27-1, Lane 169, Kang-Ning St., Hsi-Chih,  
Taipei Hsien, Taiwan, R. O. C.

TEL : 886-2-26922097 FAX : 886-2-26956236

## 2. Product Information

- a. **EUT Type:** PRESENTER
- b. **Transmitter Model:** PRESENTER
- c. **TX FCC ID:** P5A002
- d. **TX Channel No. :** One
- e. **TX Working Freq. :** 2471 MHz
- f. **TX Modulation :** FSK
- g. **TX Crystal / Osc. :** 4 MHz, 10 MHz, 18.432 MHz
- h. **TX Port(s) :** N/A
- i. **TX Transmitting Power :** DC 3V
- j. **TX Power Supply :** AAA \* 2 Batteries
- k. **TX Case :** ABS
- l. **EUT Condition :**  Prototype  Engineering  Production
- m. **EUT Received Date :** DEC. 15, 2004

### **3. EUT Description and Test Methods**

- (A) The EUT is PRESENTER, FCC ID: P5A002, model PRESENTER. The EUT that comes with a trace ball and five function buttons is optical wireless mouse. DC 3V from two rechargeable batteries (size AAA, DC1.5V) is required to operate EUT. The radio frequency of EUT is 2471MHz. For more detail information about the EUT, please refer to the user's manual.
  
- (B) Test Method: According to the major function designed, the EUT placement on test table was arranged alone to proceed with test. The test was carried out on EUT operational condition of Tx-On mode: continuous transmission state. The worst-case test result of each test mode was recorded and provided in this report.
  
- (C) At the frequencies where the peak values of the emission exceeded the quasi-peak limit, the emissions were also measured with the quasi-peak detectors. The average detector also measured the emission either (A) quasi-peak values were under quasi-peak limit but exceeded average limit, or (B) peak values were under quasi-peak limit but exceeded average limit.

## **4. Modification(s):**

N/A

## **5. Test Software Used**

N/A

## 6. Support Equipment Used

N/A

## 7. Description Field Strength of Fundamental and Harmonics Test

### 7.1 Field Strength of Fundamental and Harmonics Test

Field Strength of Fundamental and Harmonics Test were made outdoors at 3-meter test range using horn antenna. The test equipment was placed on a wooden bench situated on a 1.5x1 meter area adjacent to the measurement area. Sufficient time for the EUT, support equipment, and test equipment was allowed in order for them to warm up to their normal operating condition. The detector function was set to peak and average value, the bandwidth of the receiver was set to 1000MHz.

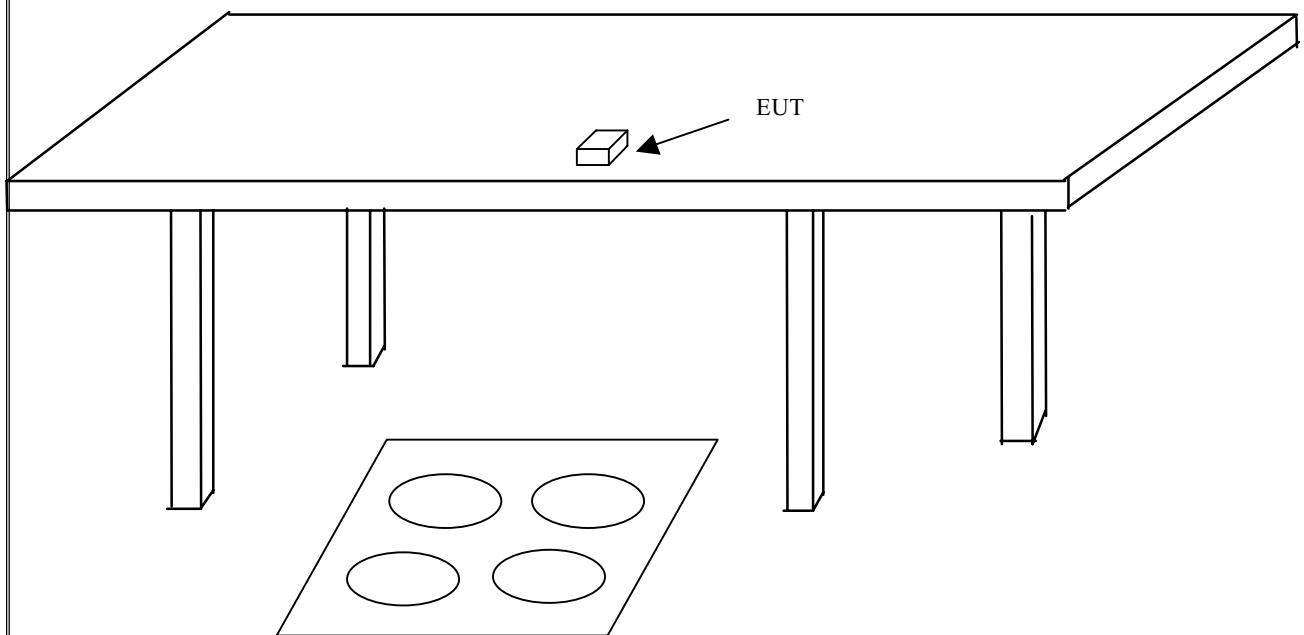
The turntable containing the system was rotated; the antenna height was varied 1 to 4 meters and stopped at the azimuth or height producing the maximum emission.

### 7.2 Field Strength of Fundamental and Harmonics Limits

Fundamental Frequency	Fundamental		Harmonics	
	( mV/m )	( dB $\mu$ V/m )	( $\mu$ V/m )	( dB $\mu$ V/m )
902-928MHz	50	94	500	54
2400-2483.5MHz	50	94	500	54
5725-5875MHz	50	94	500	54
24.0-24.25GHz	250	108	2500	68



### 7.3 Test Configuration



## 8. Description of Conducted Emissions Test

### 8.1 Conducted Emissions

A 1m x1.5m wooden table 80 cm high is placed 40cm away from the vertical wall. Two AMN are bonded to the grounding plane. The EUT is powered from the designated AMN and the support equipment is powered from another designated AMN. Powers to the AMN are filtered by a high-current high insertion loss power line filters. All electrical cables are shielded by braided tinned copper zipper tubing with inner diameter of 1/2". All interconnecting cables more than 1 meter were shortened by non-inductive bundling (serpentine fashion) to a 1-meter length.

Sufficient time for the EUT, support equipment, and test equipment was allowed in order for them to warm up to their normal operating condition. The RF output of the AMN was connected to the spectrum analyzer to determine the frequency producing the maximum EME from the EUT.

The spectrum was scanned from 150kHz to 30 MHz with 1.5 sec sweep time. The frequency producing the maximum level was re-examined using Quasi-Peak adapter. The detector function was set to CISPR quasi-peak mode. The bandwidth of the receiver was set to 10kHz. The EUT, support equipment, and interconnecting cables were re-arranged and manipulated to maximize each EME emission. Each emission was maximized by: switching power lines; varying the mode of operation or resolution; clock or data exchange speed; scrolling H pattern to the EUT and/or support equipment, and powering the monitor from the floor mounted outlet box and the computer aux AC outlet, if applicable; whichever determined the worst-case emission.

### 8.2 Conducted Emissions Limits

Frequency	Maximum RF Line Voltage dB(uV)			
	Class A		Class B	
MHz	QUASI-PEAK	AVERAGE	QUASI-PEAK	AVERAGE
0.15 - 0.50	79	66	66-56	56-46
0.50 - 5.0	73	60	56	46
5.0 - 30	73	60	60	50

Remarks : In the above table, the tighter limit applies at the band edges.

## **9. Description of Radiated Emissions Test**

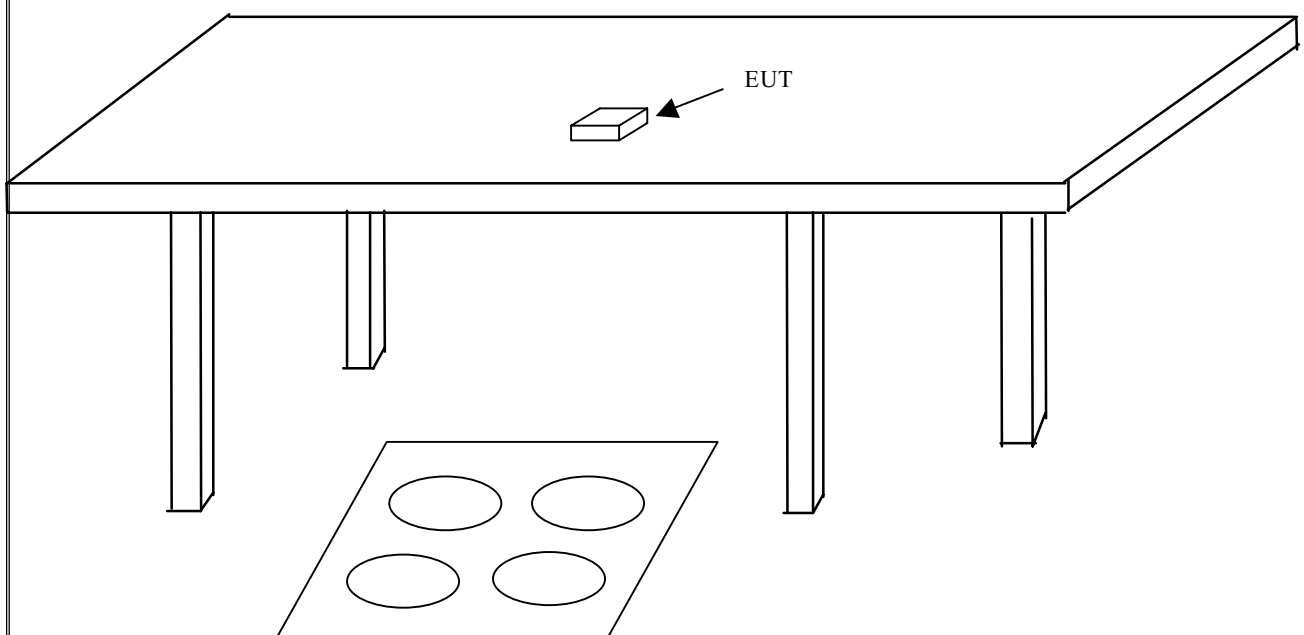
### **9.1 Radiated Emissions**

Preliminary measurements were made indoors chamber at 3 meter using broadband antennas, broadband amplifier, and spectrum analyzer to determine the frequency producing the maximum EME. Appropriate precaution was taken to ensure that all EME from the EUT were maximized and investigated. The system configuration, clock speed, mode of operation or video resolution, turntable azimuth with respect to the antenna were noted for each frequency found. The spectrum was scanned from 30 to 1000 MHz using logbicon antenna. Above 1GHz, linearly polarized double ridge horn antenna was used.

Final measurements were made outdoors at 3-meter test range using logbicon antenna and horn antenna. The test equipment was placed on a wooden bench situated on a 1.5x1 meter area adjacent to the measurement area. Sufficient time for the EUT, support equipment, and test equipment was allowed in order for them to warm up to their normal operating condition. Each frequency found during pre-scan measurements was re-examined and investigated using Quasi-Peak and Average Adapter. 30MHz-1GHz, the detector function was set to CISPR quasi-peak mode and the bandwidth of the receiver was set to 120kHz. Above 1GHz, the detector function was set to peak and average value, the bandwidth of the receiver was set to 1000MHz.

The turntable containing the system was rotated; the antenna height was varied 1 to 4 meters and stopped at the azimuth or height producing the maximum emission. Each emission was maximized by: varying mode of operation or resolution; clock or data exchange speed; scrolling H pattern to the EUT and/or support equipment, and powering the monitor from the floor mounted outlet box and the computer aux AC outlet , if applicable; and changing the polarity of the antenna, whichever determined the worst-case emission. Photographs of the worst-case emission can be seen in radiated emission test photo.

## 9.2 Test Configuration



### **9.3 Radiated Emission Limits**

Limits for radiated disturbance of  
Class B ITE or Intentional Radiator  
At a measuring distance of 3 m

Frequency MHz	Field Strength dB $\mu$ V/m or uV/m	
30 to 88	40	100
88 to 216	43.5	150
216 to 960	46	200
Above 960	56	500

**NOTES**

- 1 The lower limit shall apply at the transition frequency.
- 2 Additional provisions may be required for cases where interference occurs.

## 10. Field Strength of Fundamental and Harmonics Test Setup Photos

< FRONT VIEW >



< REAR VIEW >



# 11. Field Strength of Fundamental and Harmonics Test Data

**Model No.** : PRESENTER  
**Temperature** : 28° C                      **Humidity** : 54 %  
**Memo** : TX ON MODE

**Antenna polarization : HORIZONTAL ; Test distance : 3m ;**

Freq. (MHz)	Level (dBuV/m)	Over Limit (dB)	Limit Line (dBuV/m)	Detector	Remark
2471.070	76.35	-37.65	114	Peak	Fundamental
2470.870	75.76	-18.24	94	Average	Fundamental
4942.000	56.46	-17.54	74	Peak	Harmonic
4943.000	48.93	- 5.07	54	Average	Harmonic
7414.000	48.49	-25.51	74	Peak	Harmonic
7411.000	40.71	-13.29	54	Average	Harmonic

**Antenna polarization : VERTICAL ; Test distance : 3m ;**

Freq. (MHz)	Level (dBuV/m)	Over Limit (dB)	Limit Line (dBuV/m)	Detector	Remark
2470.700	78.41	-35.59	114	Peak	Fundamental
2470.900	77.82	-16.18	94	Average	Fundamental
4942.000	58.82	-15.18	74	Peak	Harmonic
4942.000	52.33	- 1.67	54	Average	Harmonic
7411.000	48.59	-25.41	74	Peak	Harmonic
7411.000	40.72	-13.28	54	Average	Harmonic

## **12. Conducted Emissions Test Setup Photos**

N/A

## **13. Conducted Emissions Test Data**

The EUT is supplied by DC power source from batteries. The conducted powerline test is not applicable to EUT.



FCC ID: P5A002

## 14. Radiated Emissions Test Setup Photos

< FRONT VIEW >



< REAR VIEW >



## 15. Radiated Emissions Test Data

### 15.1 Field Strength of Fundamental and Harmonics Test Data

**Model No.** : PRESENTER  
**Frequency range** : 30MHz to 1GHz **Detector** : Quasi-Peak Value  
**Temperature** : 28° C **Humidity** : 55 %  
**Memo** : TX ON MODE

**Antenna polarization** : HORIZONTAL ; **Test distance** : 3m ;

Freq. (MHz)	Level (dBuV/m)	Over Limit (dB)	Limit Line (dBuV/m)	Read Level (dBuV)	Antenna Factor (dB)	Cable Loss (dB)	Preamp Factor (dB)	Azimuth (°angle)	Antenna High(m)
75.090	27.28	-12.72	40.00	27.87	6.15	1.11	7.85	302.0	4.0
104.790	28.03	-15.47	43.50	27.23	10.73	1.27	11.20	198.0	4.0
200.370	23.85	-19.65	43.50	28.17	8.77	1.93	15.02	18.0	4.0
258.420	26.28	-19.72	46.00	27.24	13.04	2.28	16.28	279.0	3.5
542.900	39.81	- 6.19	46.00	35.24	18.63	3.18	17.24	311.0	3.0
825.700	37.44	- 8.56	46.00	28.23	20.33	4.08	15.20	208.0	3.5
976.200	34.49	-19.51	54.00	26.68	20.89	4.59	17.67	208.0	3.5

Note :

1. Level = Read Level + Probe Factor + Cable Loss – Preamp Factor
2. Over Limit = Level – Limit Line

**Model No.** : PRESENTER  
**Frequency range** : 30MHz to 1GHz **Detector** : Quasi-Peak Value  
**Temperature** : 28° C **Humidity** : 55 %  
**Memo** : TX ON MODE

**Antenna polarization** : VERTICAL ; **Test distance** : 3m ;

Freq. (MHz)	Level (dBuV/m)	Over Limit (dB)	Limit Line (dBuV/m)	Read Level (dBuV)	Antenna Factor (dB)	Cable Loss (dB)	Preamp Factor (dB)	Azimuth (° angle)	Antenna High(m)
71.850	28.38	-11.62	40.00	26.68	5.65	1.09	5.04	142.0	1.0
122.340	30.37	-13.13	43.50	27.79	11.37	1.43	10.22	217.0	1.0
189.300	36.11	- 7.39	43.50	41.77	8.53	1.81	16.00	114.0	1.0
500.900	33.43	-12.57	46.00	28.22	17.30	3.01	15.10	215.0	1.5
566.700	34.36	-11.64	46.00	27.35	18.73	3.28	15.00	315.0	1.5
830.600	36.93	- 9.07	46.00	28.44	20.36	4.09	15.96	73.0	2.5

Note :

1. Level = Read Level + Antenna Factor + Cable Loss – Preamp Factor
2. Over Limit = Level – Limit Line

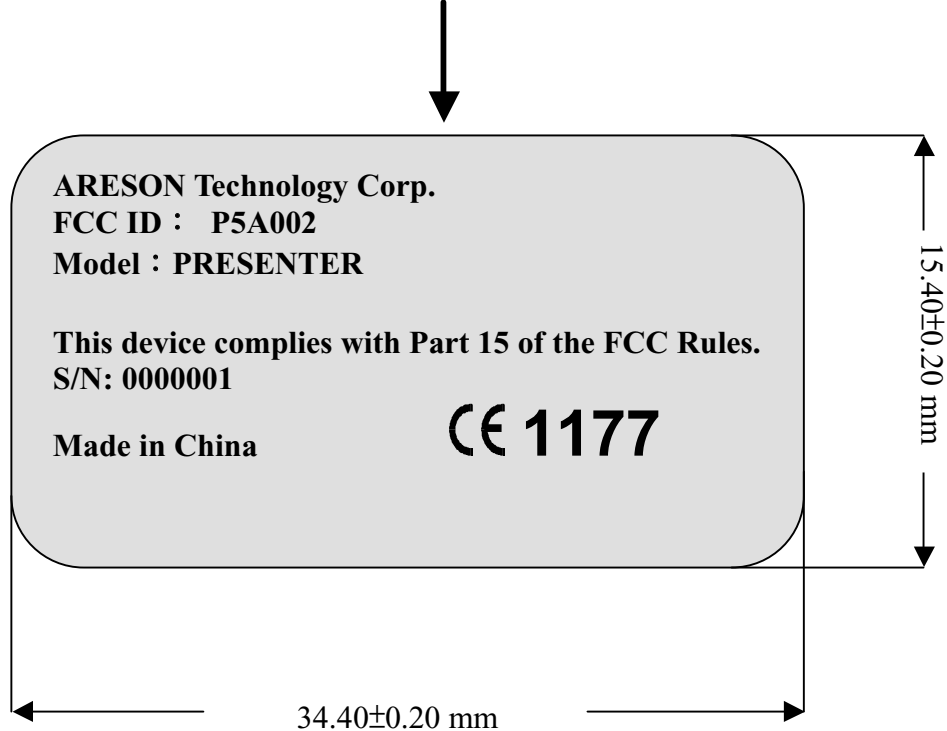
## 16. List of Measured Instruments

Test Mode	Instrument	Model No.	Serial No.	Next Cal. Date	Cal. Interval
<b>Radiation (OP No.3)</b>	R & S Receiver	ESBI	845658/003	July 27, 2005	1Year
	Schaffner Pre-Amp.	CPA-9232	1012	Aug. 19, 2005	1Year
	SCJWARZBECL Antenna	VULB9161	D-69250	May 19, 2005	1Year
	COM-Power Horn Ant.	AH-118 (1GHz~18GHz)	10095	May 25, 2005	1Year
	RF Cable	No.2	N/A	Feb. 19, 2005	1Year
	SCHWARZBECK Precision Dipole Ant.	VHAP (30MHz~1GHz)	970+971 953+954	June 26, 2006	3Year
	R & S Signal Generator	SMY01	829846/038	Feb. 16, 2005	2Year
<b>Radiation</b>	R & S Receiver	ESVS30	863342/012	May 20, 2005	1Year
	R&S Spectrum	FSP7 (9K-7GHz)	830180/006	June 28, 2005	1Year
	R&S Spectrum	FSP30 (9K-30GHz)	100157	Aug, 27, 2005	1Year
	COM-Power Horn Ant.	AH-118 (1G-18GHz)	10056	May. 21, 2005	2Year
	EMCO ANTENNA	3142B (26M-2GHz)	9904-1307	Aug. 25, 2005	1Year
	Schaffner Antenna	CBL6112B (30M-2GHz)	2655	July 27, 2005	1Year
	Anritsu Pre-Amp.	MH648A	M15080	Apr. 10, 2005	1Year
	MITEQ Pre-amplifier	JS4-00101800 (1G-18GHz)	513015	Nov. 26, 2007	3 Year
	Schmidt DC Power	EPS-3030SD (DC 0-30V)	E010001	Sep. 05, 2005	2 year
	Giant Force Humidity Chamber	GTH-225-20-S	MAB0103 -001	Feb. 28, 2005	1 year

## 17. FCC ID Label Sample

The sample label shown below shall be permanently affixed at a conspicuous location on the device, instruction manual or pamphlet supplied to the user and be readily visible to the purchaser at the time of purchase. However, when the device is so small wherein placement of the label with specified statement is not practicable, only the trade name, model number, and the FCC logo must be displayed on the device per Section §15.19 (b)(2).

### EUT Label



## **18. Information To The User**

For a Class B digital device or peripheral, the instructions furnished the user shall include the following or similar statement, placed in a prominent location in the text of the manual:

### Federal Communications Commission (FCC) Statement

This equipment has been tested and found to comply with the limits for a Class B digital device, pursuant to Part 15 of the FCC Rules. These limits are designed to provide reasonable protection against harmful interference in a residential installation. This equipment generates, uses and can radiate radio frequency energy and, if not installed and used in accordance with the instruction, may cause harmful interference to radio communications. However, there is no guarantee that interference will not occur in a particular installation. If this equipment does cause harmful interference to radio or television reception, which can be determined by turning the equipment off and on, the user is encouraged to try to correct the interference by one or more of the following measures :

- Reorient or relocate the receiving antenna.
- Increase the separation between the equipment and receiver .
- Connect the equipment into an outlet on a circuit different from that to which the receiver is connected .
- Consult the dealer or an experienced radio / TV technician for help .

## 19. EUT External Photos

PHOTO. 1. EUT (TX) FRONT VIEW



PHOTO. 2. EUT (TX) REAR VIEW

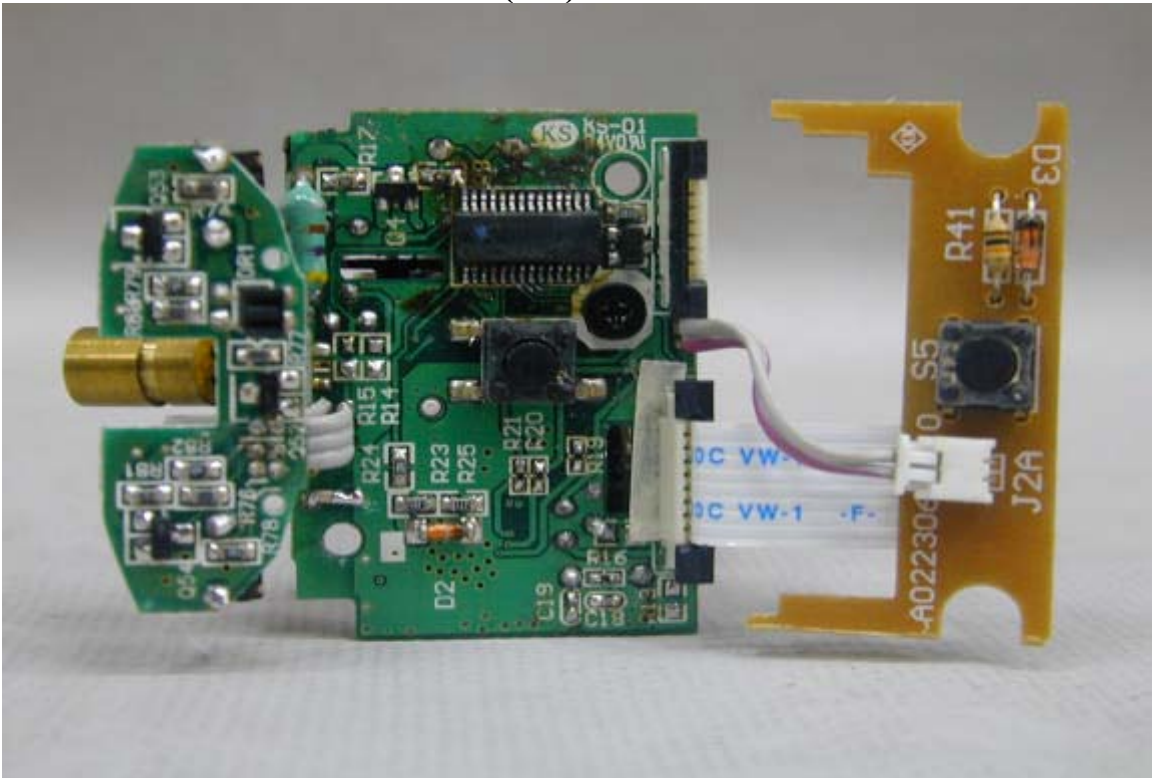


## 20. EUT Internal Photos

PHOTO. 3. EUT (TX) INSIDE VIEW

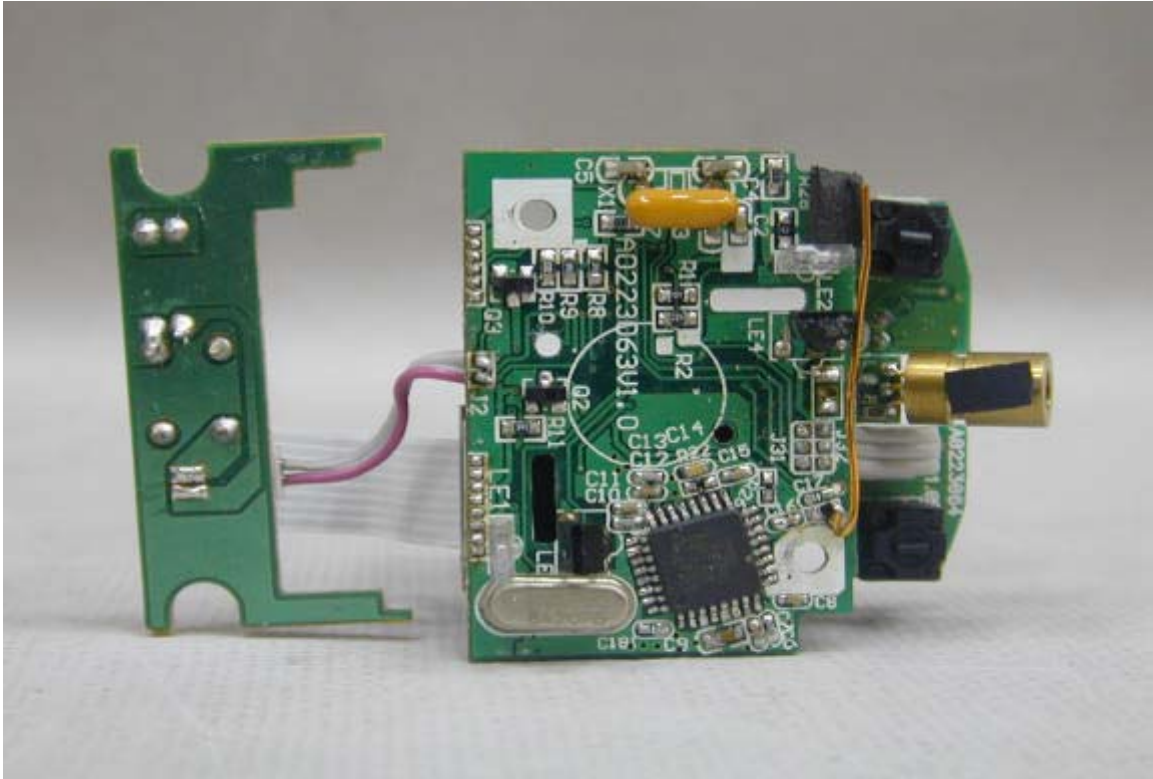


PHOTO. 4. EUT (TX) COMPONENT SIDE VIEW





**PHOTO. 5. EUT (TX) COMPONENT SIDE VIEW**



**PHOTO. 6. EUT (TX) COMPONENT SIDE VIEW**



FCC ID: P5A002

PHOTO. 7. EUT (TX) SOLDERING SIDE VIEW



PHOTO. 8. EUT (TX) SOLDERING SIDE VIEW

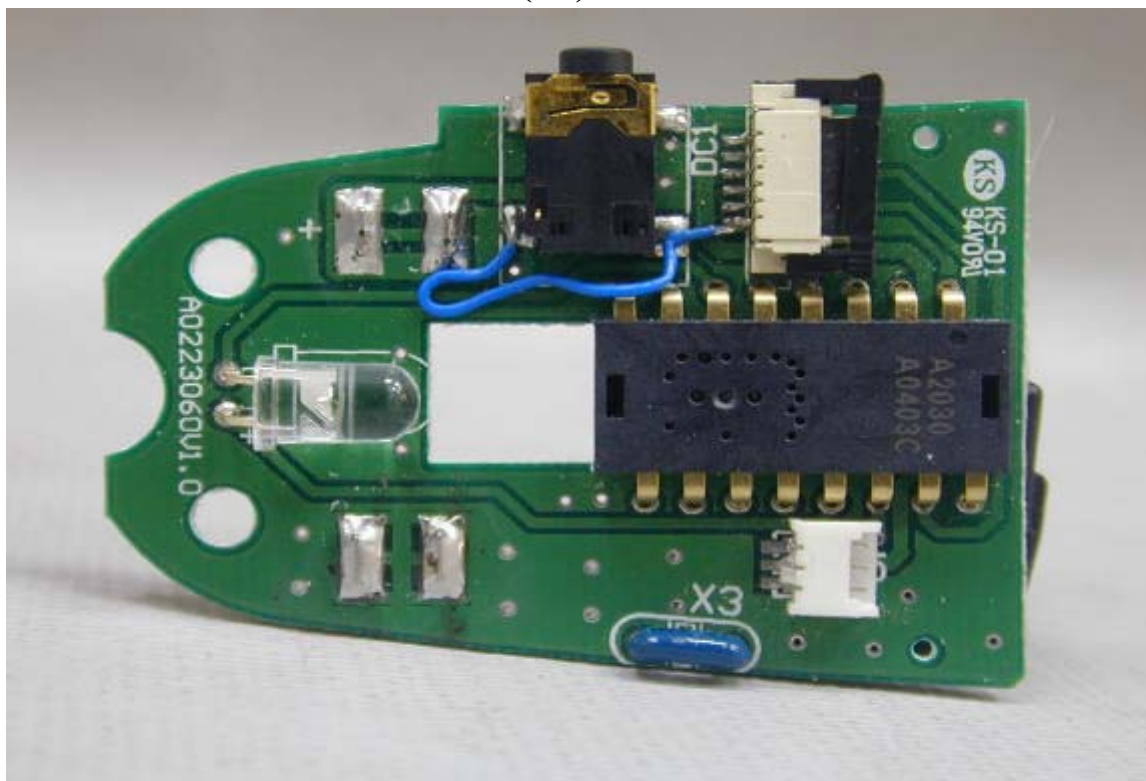


PHOTO. 9. EUT (TX) SOLDERING SIDE VIEW

