

Title		
STT-700T-MAIN		
Size	Document Number	Rev
A3	ETHERNET	0.1
Date:	Monday, April 19, 2010	Sheet 4 of 12

LCD BACK LIGHT

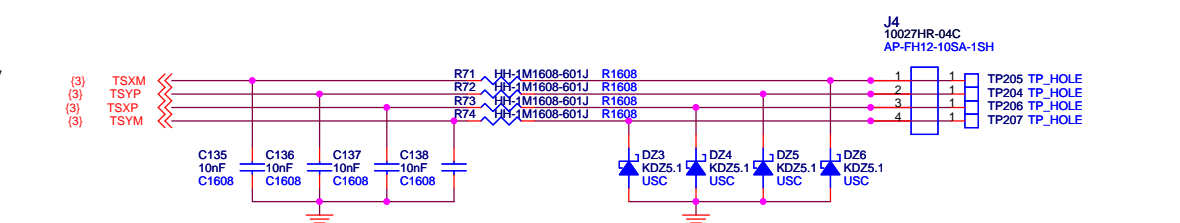

Title			STT-700T-MAIN
Size	Document Number	7" LCD	
A3		Rev	0.1
Date:	Monday, April 19, 2010	Sheet	6 of 12

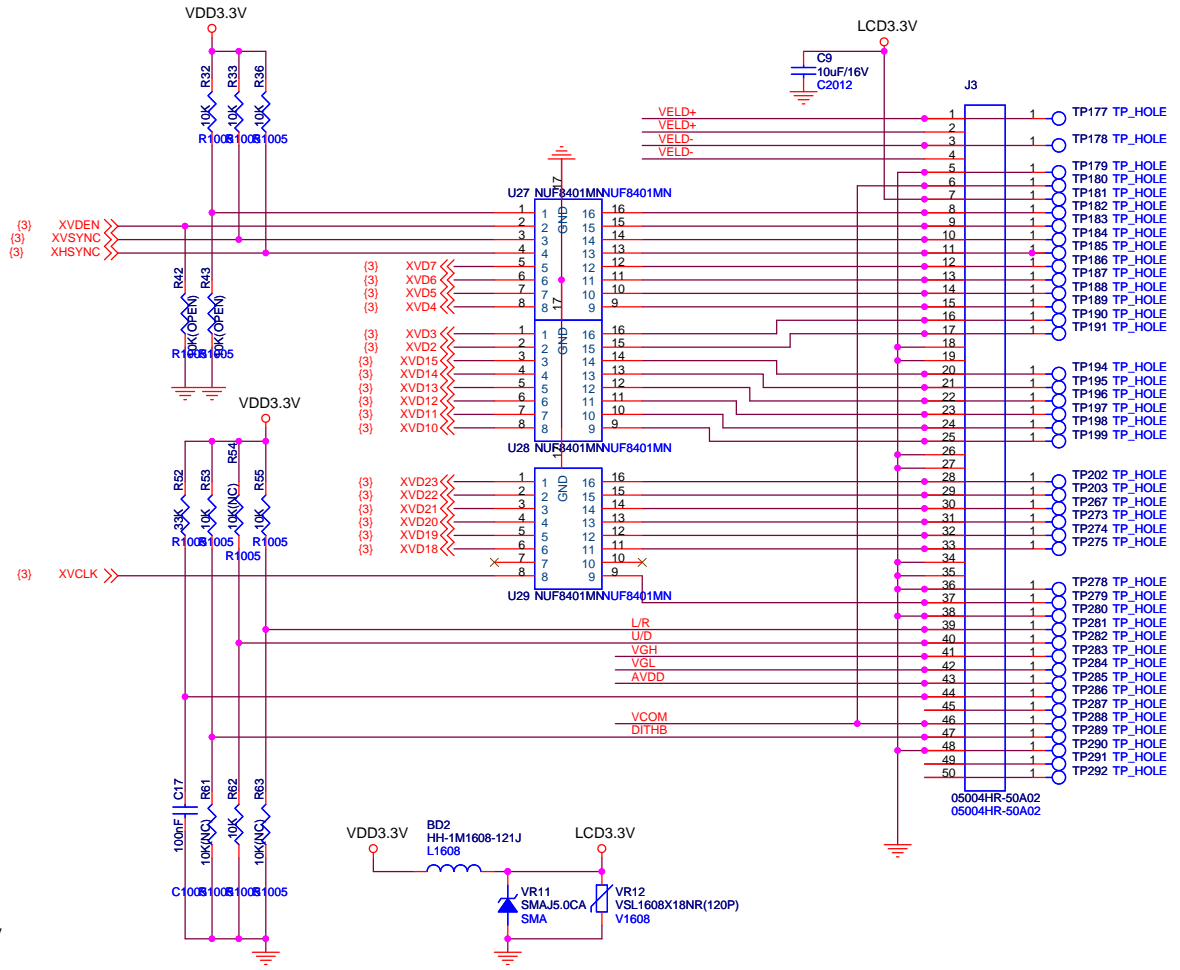
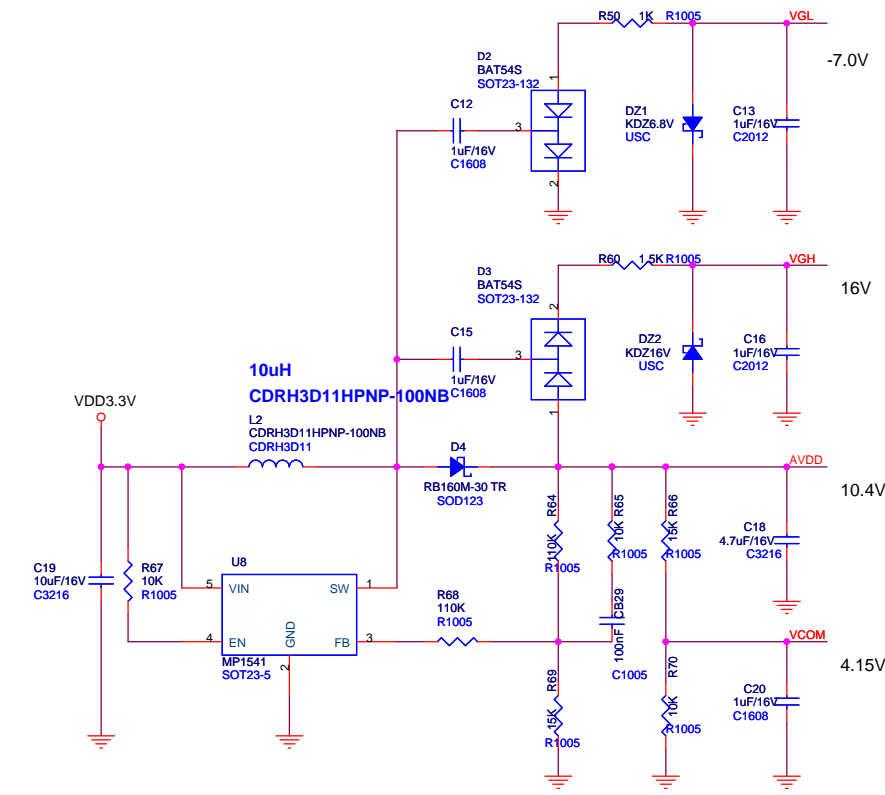
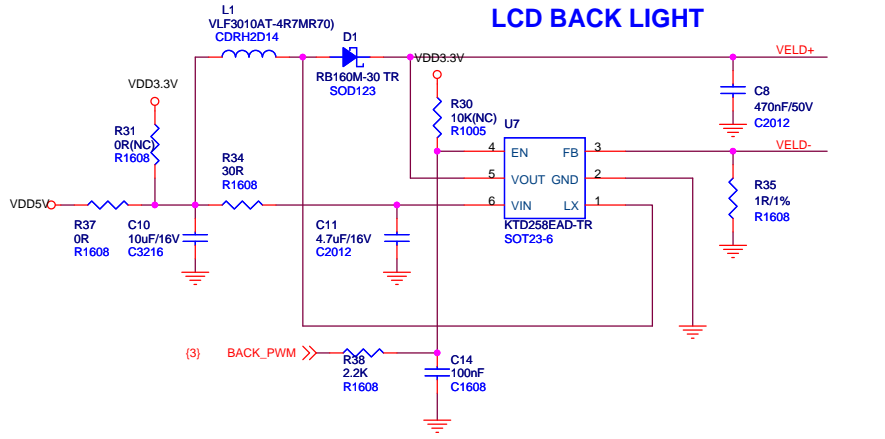
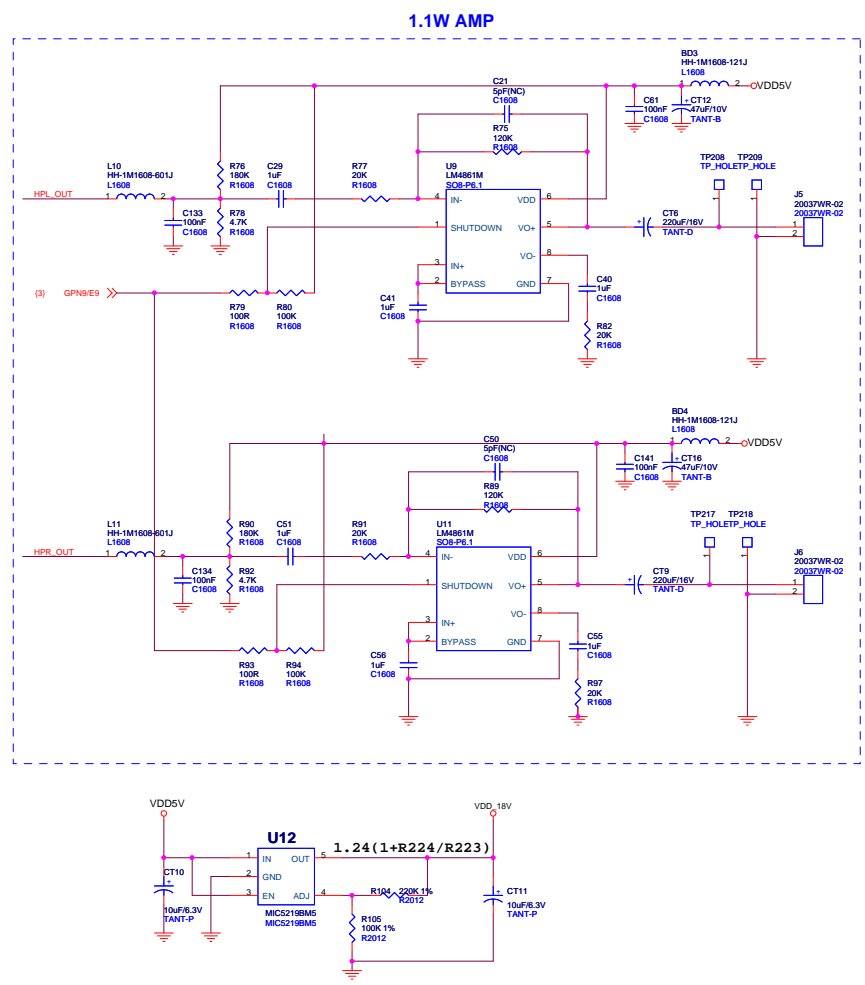
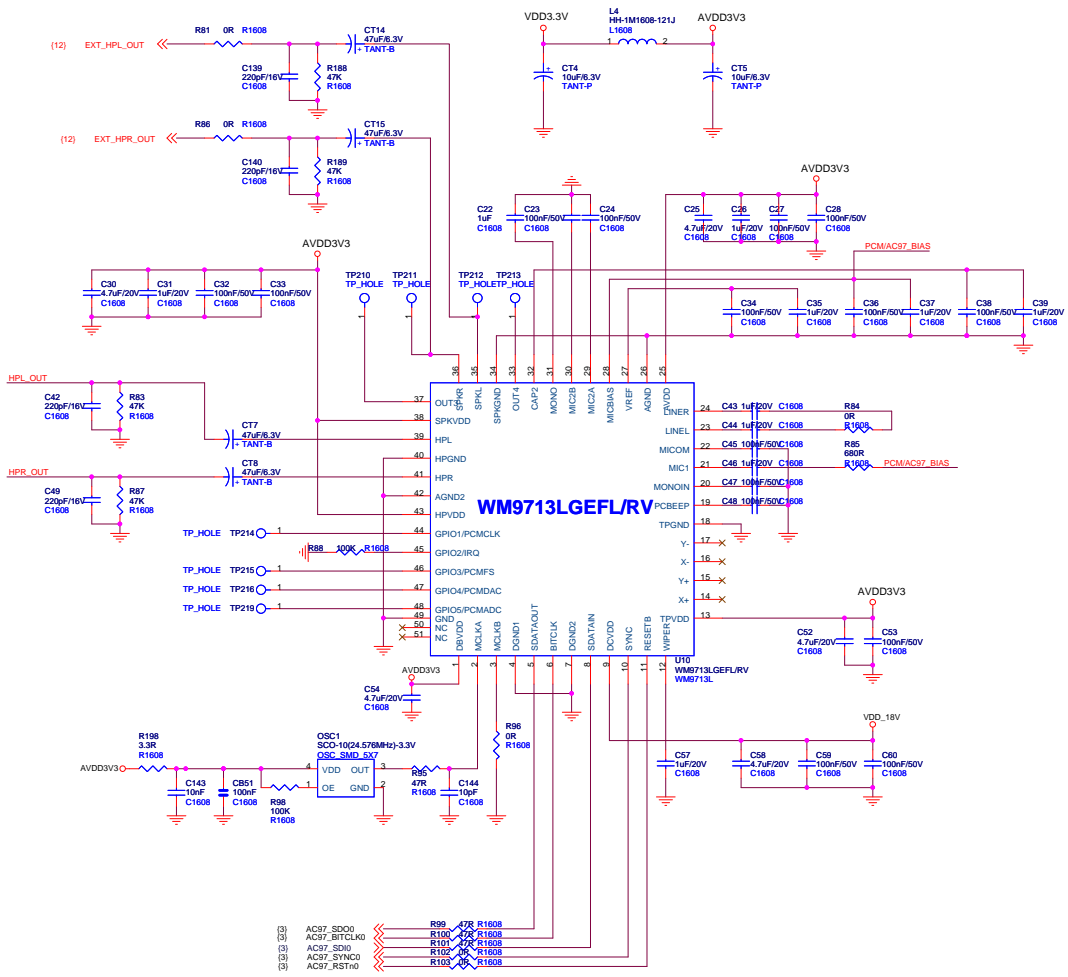

File		
STT-700T-MAIN		
Size	Document Number	Rev
A2	SOUND	0.1
Date:	Monday, April 19, 2010	Sheet 7 of 12

WIFI/BLEUETOOTH

SD CARD

SDDATA & CLK path must be same length and route

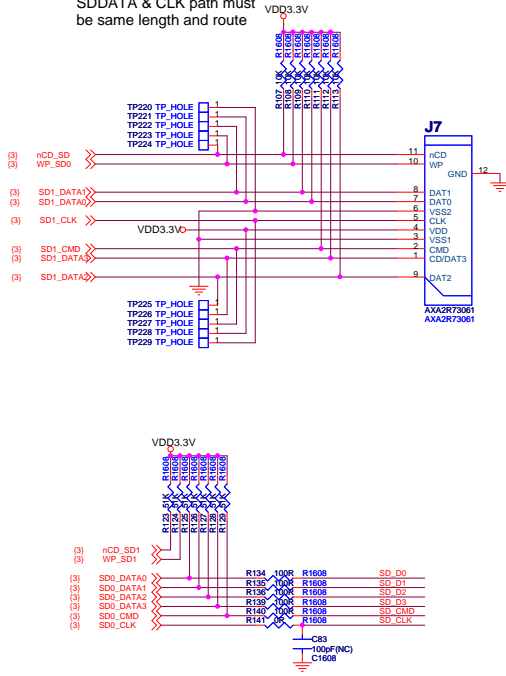

POWER

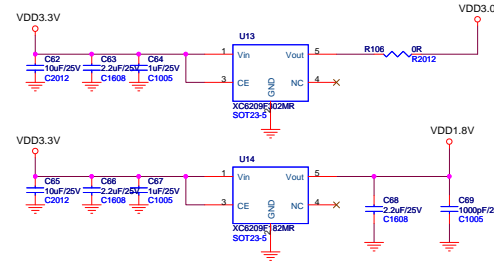

Bluetooth UART

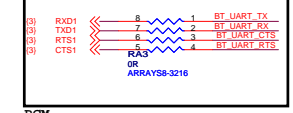

PCM

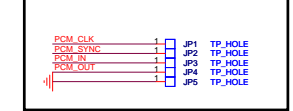

WLAN Host Interface Select

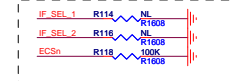

Oscillator Freq. Select

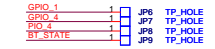
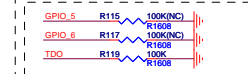

Frequency	GPIO5	GPIO6	TDO
26MHz	100K	100K	NC
40MHz	NC	NC	100K
19.2MHz	100K	NC	100K

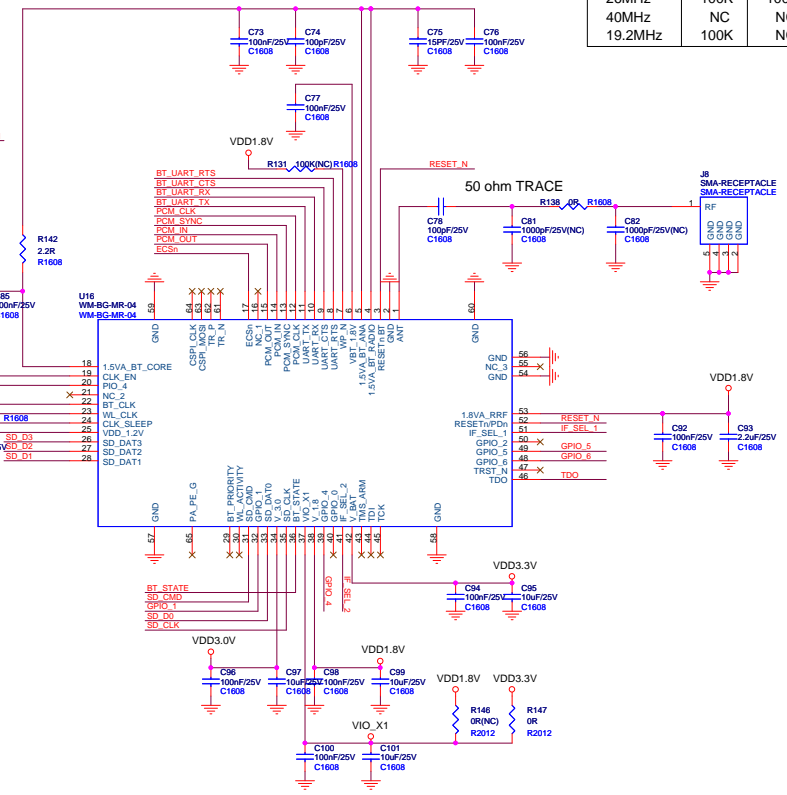
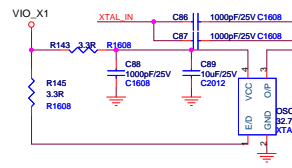
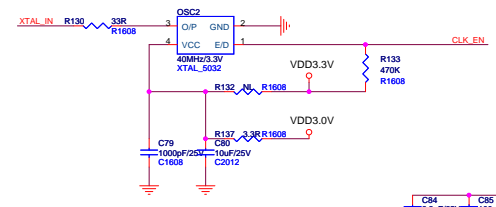
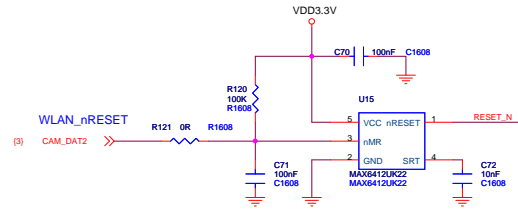

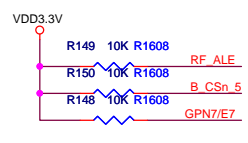
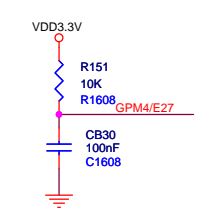
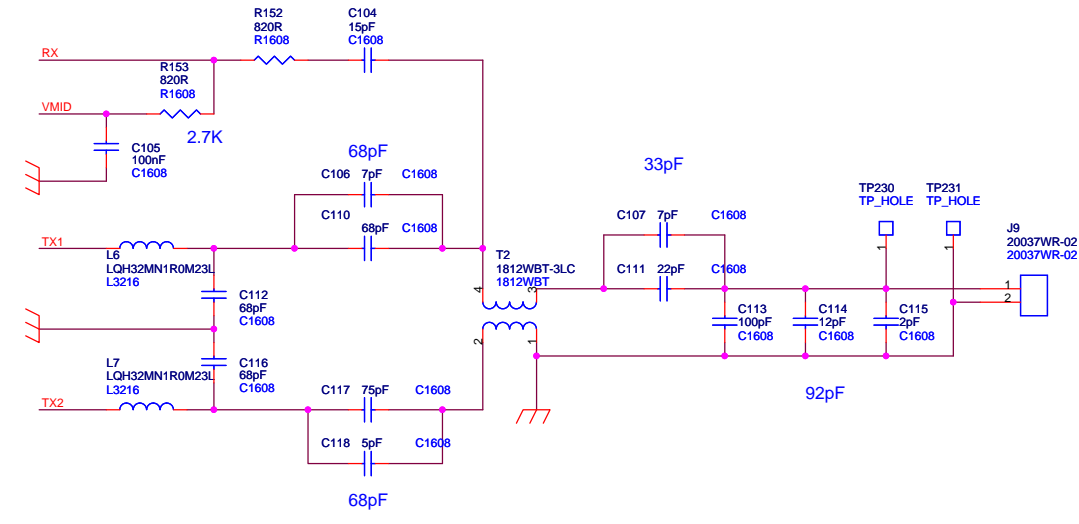
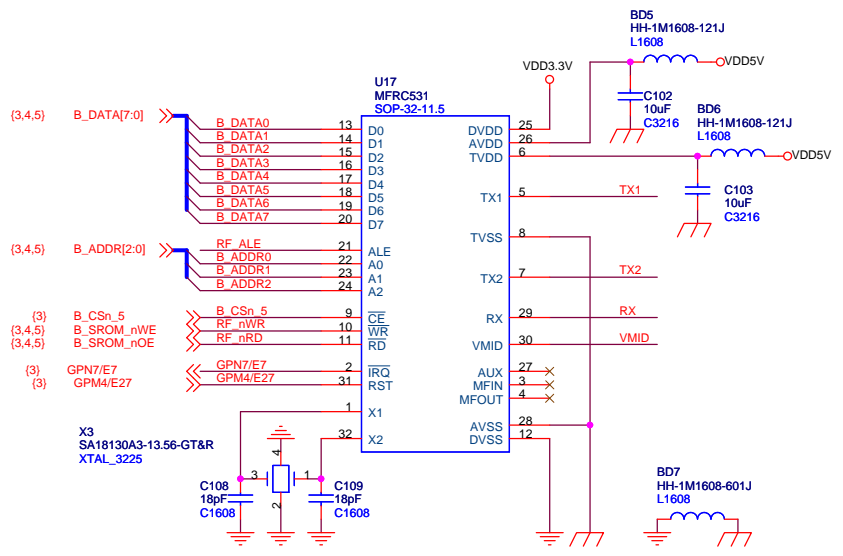

Title		
STT-700T-MAIN		
Size	Document Number	Rev
A3	RC531	0.1
Date:	Monday, April 19, 2010	Sheet 9 of 12

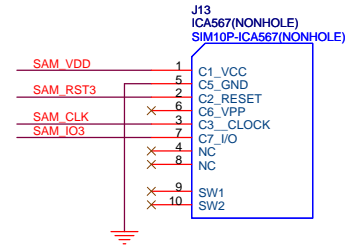
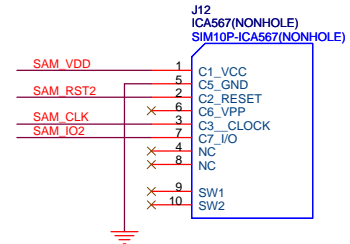
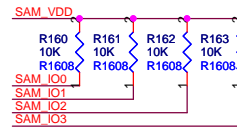
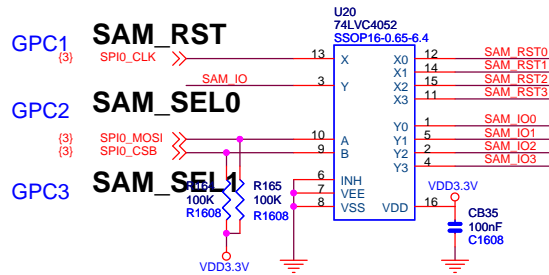
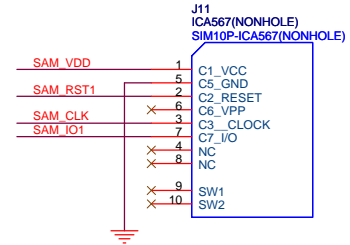
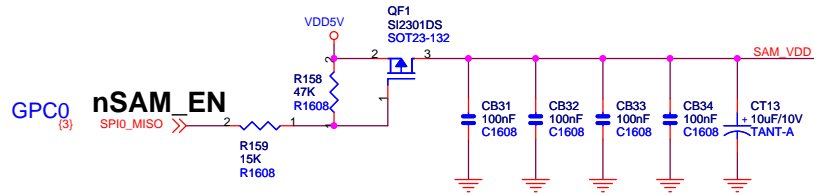
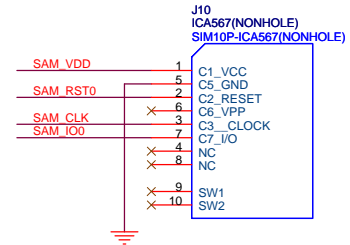
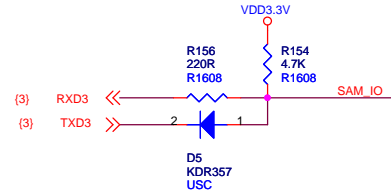
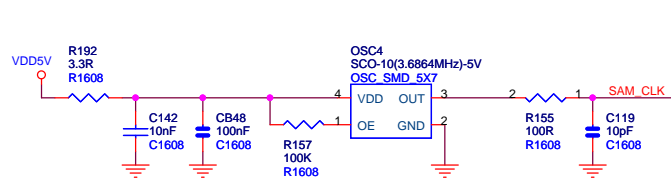

Title		
STT-700T-MAIN		
Size	Document Number	Rev
A3	4SIM	0.1
Date:	Monday, April 19, 2010	Sheet 10 of 12

MS HEAD 1

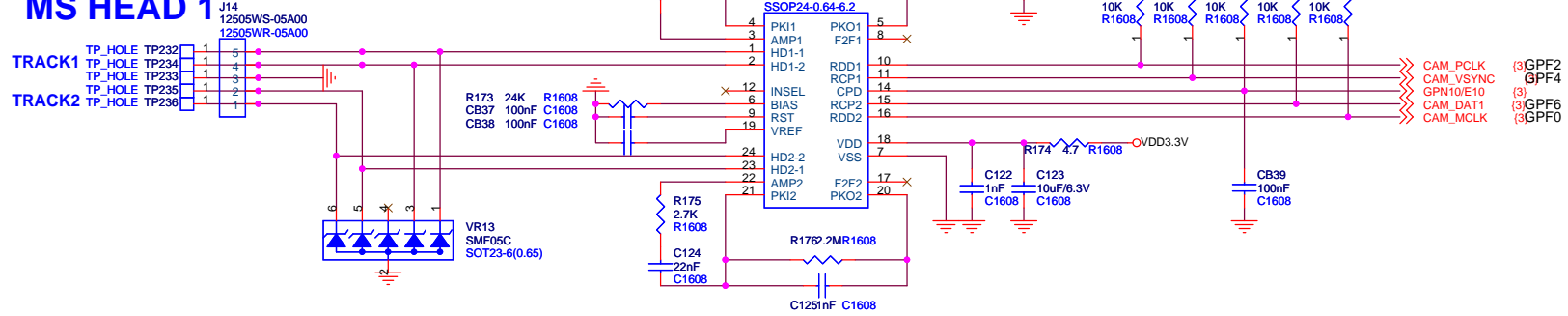

MS HEAD 2

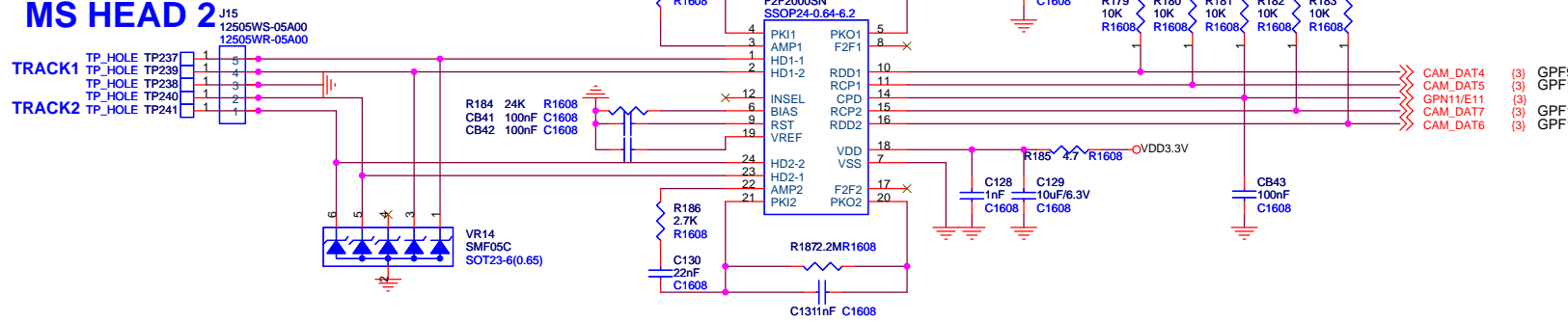

Title		
STT-700T-MAIN		
Size	Document Number	Rev
A3	MSR-12	0.1
Date:	Monday, April 19, 2010	Sheet 11 of 12

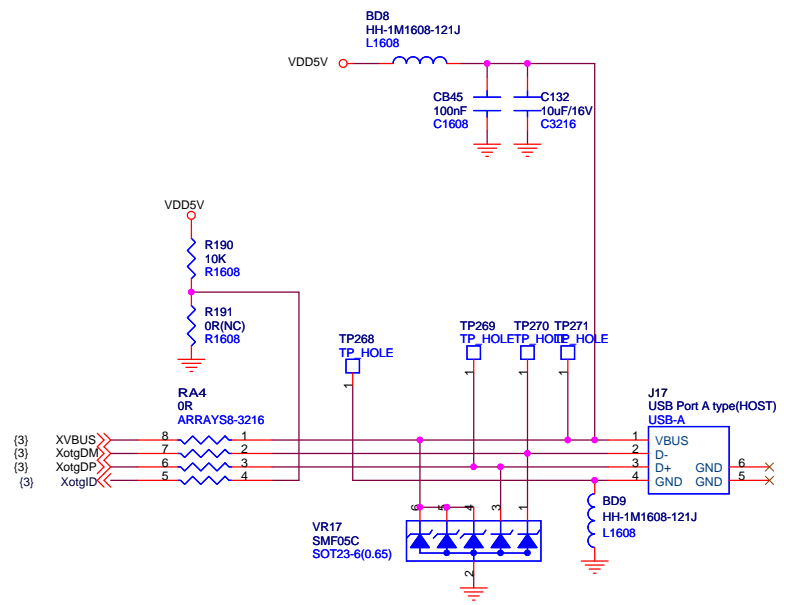
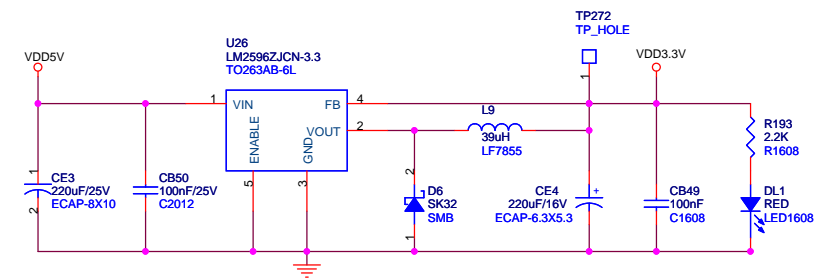
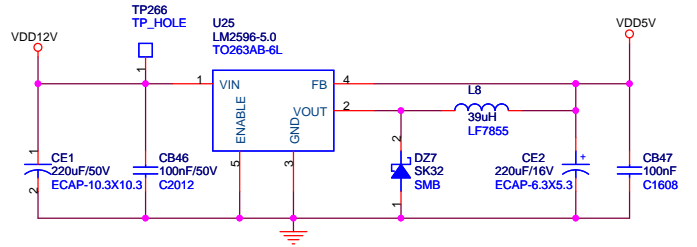
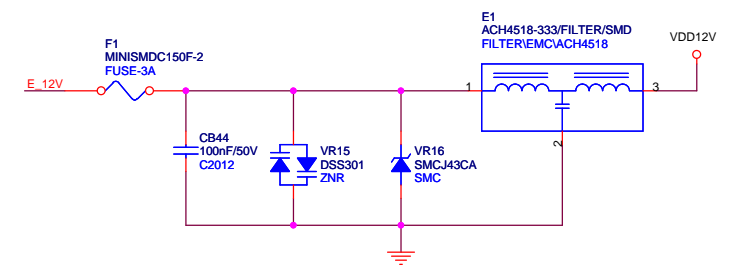
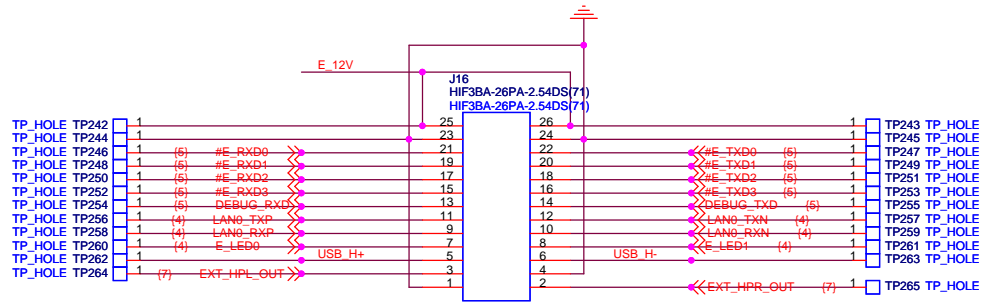

**USB-HOST
(FOR CDMA)**

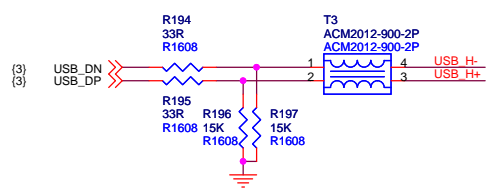

**USB-HOST
(FOR MEMORY)**

Title			STT-700T-MAIN
Size	Document Number	POWER	
A3		Rev	0.1
Date:	Monday, April 19, 2010	Sheet	12 of 12

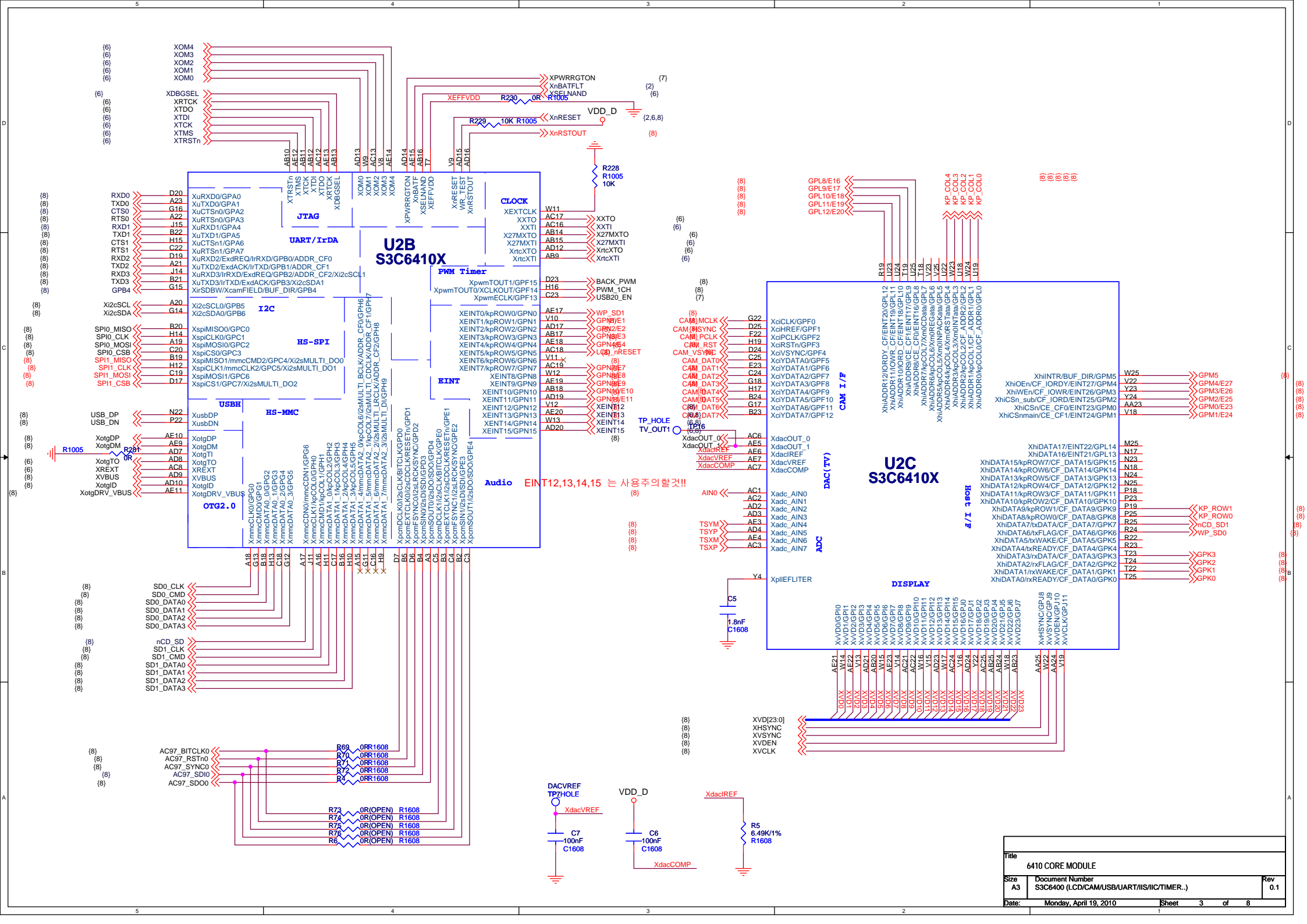

Title		
6410 CORE MODULE		
Size	Document Number	Rev
A3	S3C6400 (LCD/CAM/USB/UART/IIS/IC/TIMER..)	0.1
Date:	Monday, April 19, 2010	Sheet 3 of 8

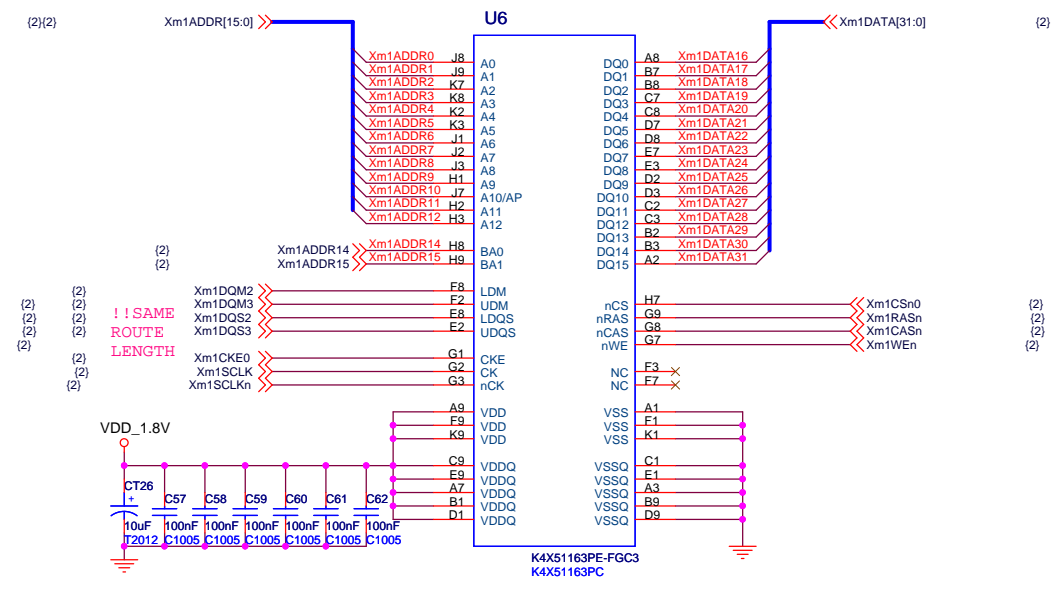
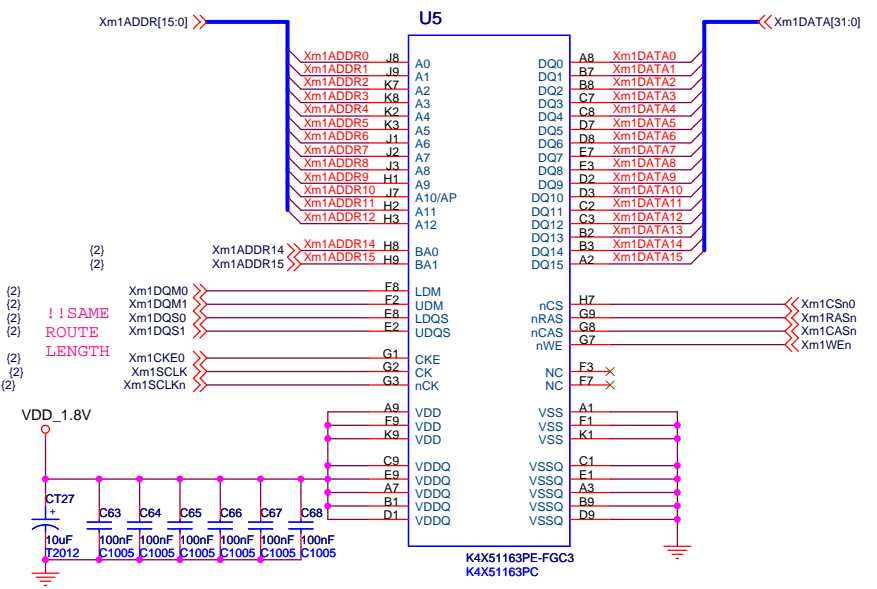

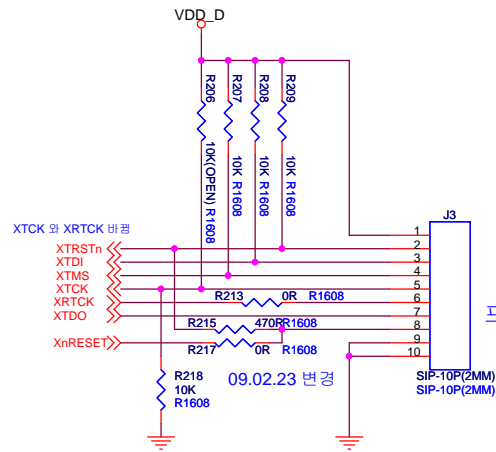
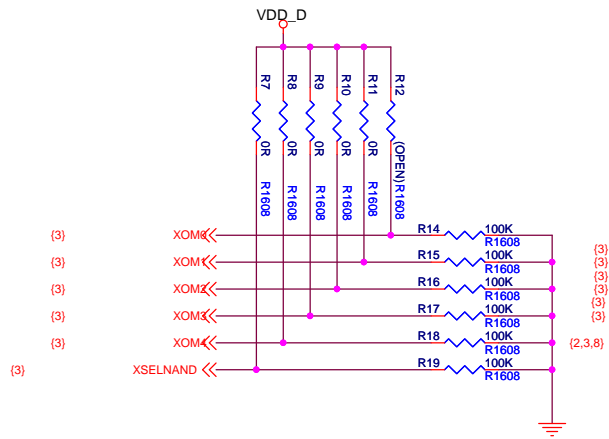

fundamental
Oscillator
tolerance +-100ppm
peak jitter 100ps
duty cycle
40/60-60/40
swing 3.3V

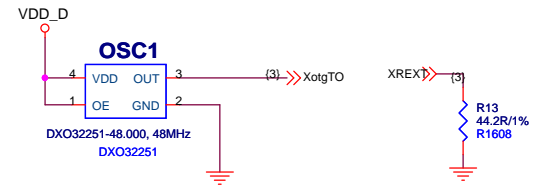

For USB Clock

프린터포트 JTAG연결시 XRTCK 풀다운

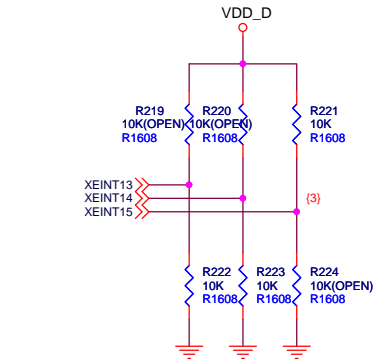

프린터포트 JTAG연결시 풀업

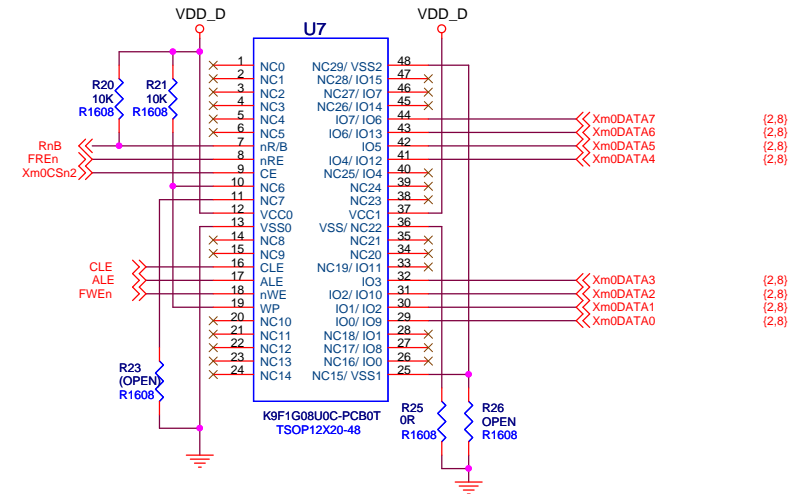
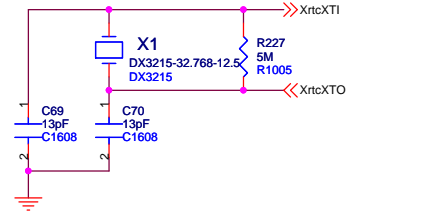
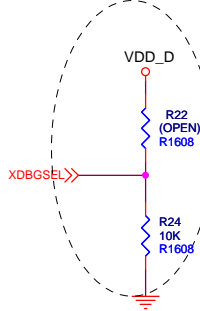

FROM Booting	Page	Address	XEINT15	XEINT14	XEINT13
SD/MMC CH0		0	0	0	0
OneNand	512	3	0	1	0
		4	0	1	1
	2048	4	1	0	0
Nand		5	1	0	1
	4096	5	1	1	0
SD/MMC CH1		1	1	1	1

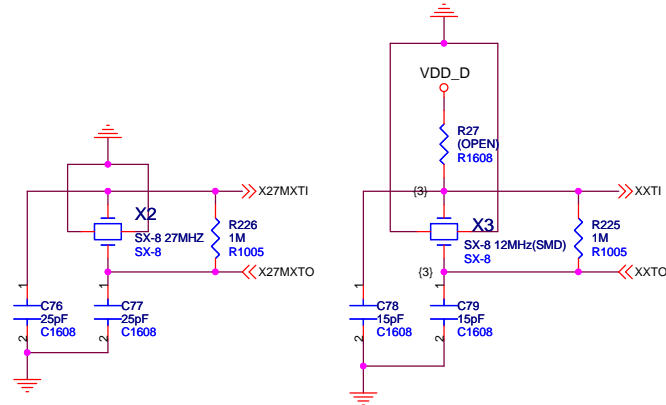

Clocks

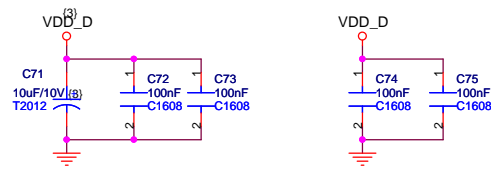

Title		
6410 CORE MODULE		
Size	Document Number	Rev
A3	MEMORY(NAND)JTAG/CLK	0.1
Date:	Monday, April 19, 2010	Sheet 6 of 8

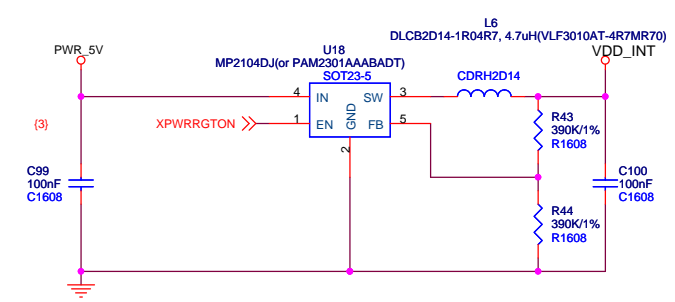
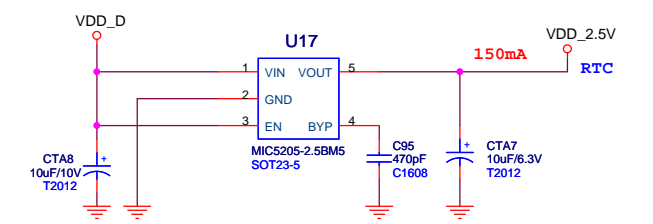
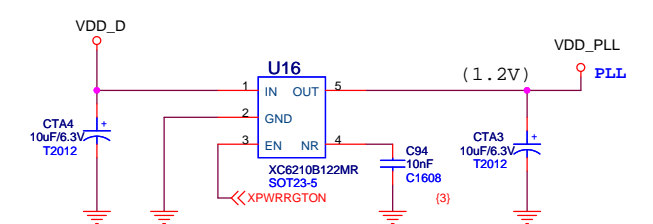
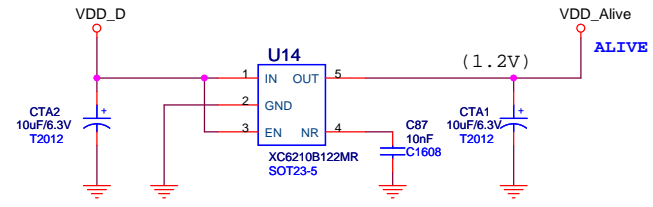
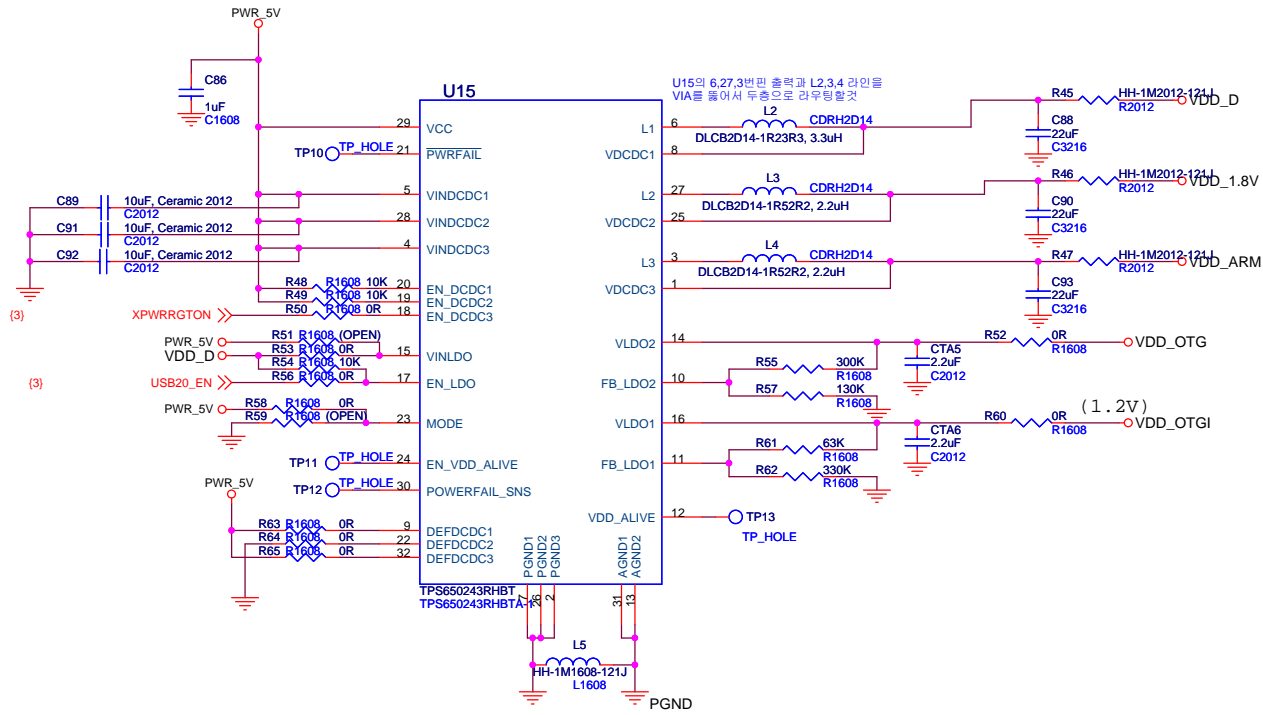

Title		
6410 CORE MODULE		
Size	Document Number	Rev
A3	TI POWER	0.1
Date:	Monday, April 19, 2010	Sheet 7 of 8

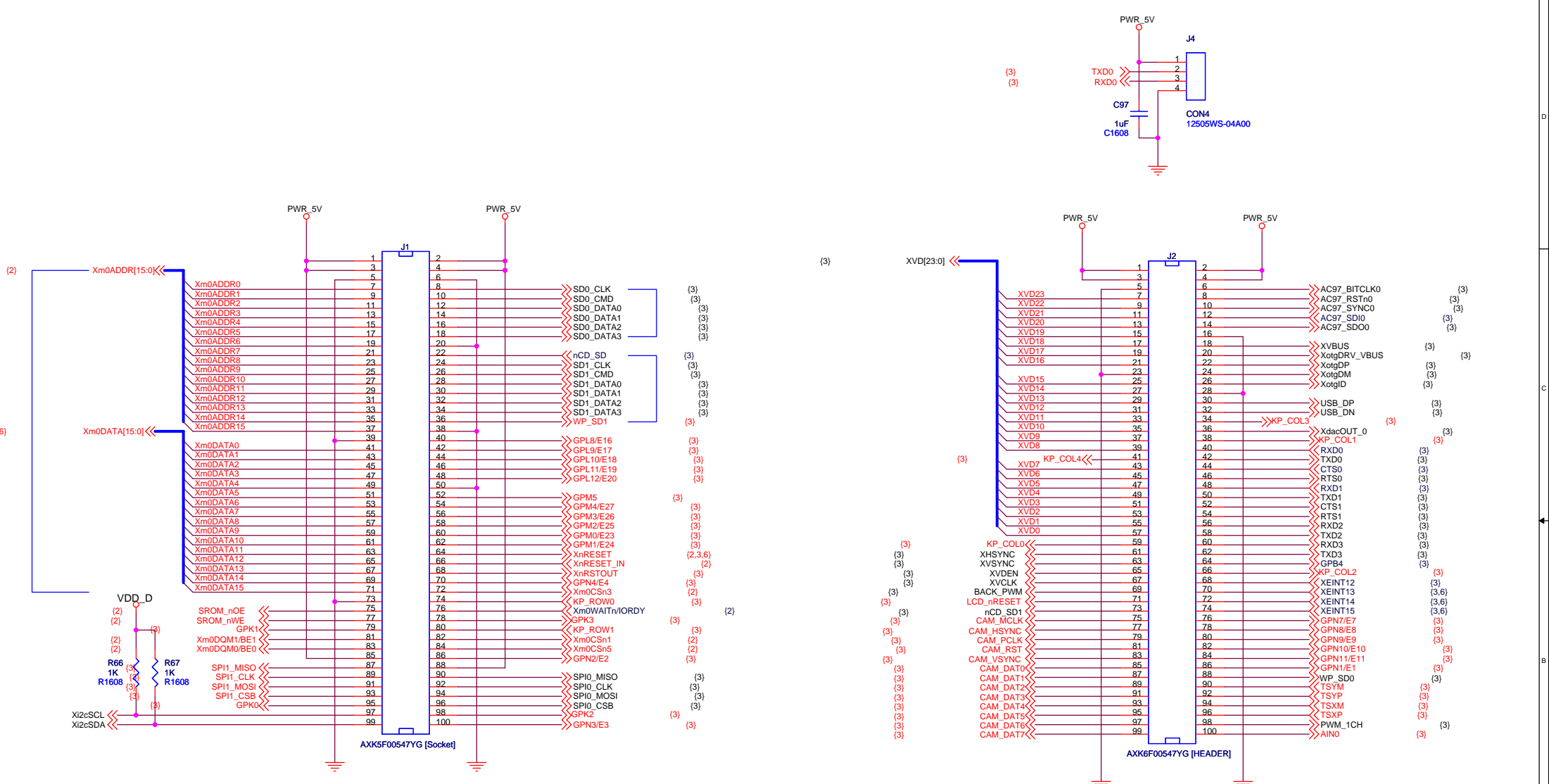

BASE BOARD
AXK6F00547YG [HEADER]

BASE BOARD
AXK5F00547YG [Socket]

Title		
6410 CORE MODULE		
Size	Document Number	Rev
A3	B TO B Connector	0.1
Date:	Monday, April 19, 2010	Sheet 8 of 8

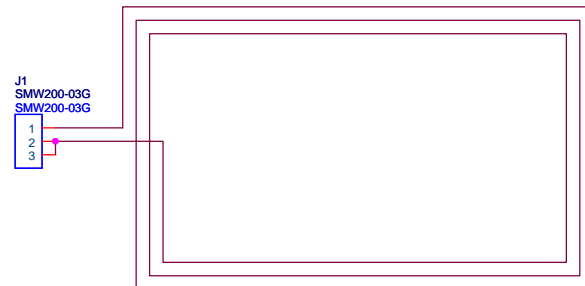
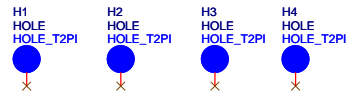

MODEL NAME	STT-700T-ANT	
DWG NO.	STT-700-ANT-X1	
DESCRIPTION	ANTENNA	Sheet 2 / 2
Date:	Monday, April 19, 2010	Size : A3