

Project No.: TM-2405000397P
Report No.: TMWK2405001767KR

FCC ID: P4Q-N702
IC: 2420C-N702

Page: 1 / 26
Rev.: 04

RADIO TEST REPORT

FCC 47 CFR PART 15 SUBPART C (CLASS II PERMISSIVE CHANGE) INDUSTRY CANADA RSS-247 (CLASS I PERMISSIVE CHANGE)

Test Standard	FCC Part 15.247 RSS-247 issue 3 and RSS-GEN issue 5
Product name	Connected Digital Recorder
Brand Name	MiTAC, Mio, MAGELLAN, Navman, SMARTER AI, Webfleet, Azuga
Model No.	N702, N702B, CAMPro US, SafetyCam Pro
Test Result	Pass
Statements of Conformity	Determination of compliance is based on the results of the compliance measurement, not taking into account measurement instrumentation uncertainty.

The test Result was tested by Compliance Certification Services Inc. The test data, data evaluation, test procedures, and equipment configurations shown in this report were given in ANSI C63.10: 2013 and compliance standards.

The test results of this report relate only to the tested sample (EUT) identified in this report.

The test Report of full or partial shall not copy. Without written approval of Compliance Certification Services Inc. (Wugu Laboratory)

Approved by:

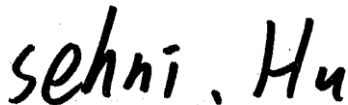

Sehni Hu
Supervisor

Unless otherwise stated the results shown in this test report refer only to the sample(s) tested and such sample(s) are retained for 90 days only.

除非另有說明，此報告結果僅對測試之樣品負責，同時此樣品僅保留90天。本報告未經本公司書面許可，不可部份複製。

This document is issued by the Company subject to its General Conditions of Service printed overleaf, available on request or accessible at <http://www.sgs.com.tw/Terms-and-Conditions> and, for electronic format documents, subject to Terms and Conditions for Electronic Documents at <http://www.sgs.com.tw/Terms-and-Conditions>. Attention is drawn to the limitation of liability, indemnification and jurisdiction issues defined therein. Any holder of this document is advised that information contained hereon reflects the Company's findings at the time of its intervention only and within the limits of client's instruction, if any. The Company's sole responsibility is to its Client and this document does not exonerate parties to a transaction from exercising all their rights and obligations under the transaction documents. This document cannot be reproduced, except in full, without prior written approval of the Company. Any unauthorized alteration, forgery or falsification of the content or appearance of this document is unlawful and offenders may be prosecuted to the fullest extent of the law.

Revision History

Rev.	Issue Date	Revisions	Effect Page	Revised By
00	July 31, 2024	Initial Issue	ALL	Peggy Tsai
01	August 14, 2024	See the following Note Rev. (01)	P. 4, 7, 8, 11, 13, 19, 21, 24, 25, A-2	Peggy Tsai
02	August 26, 2024	See the following Note Rev. (02)	P.5	Peggy Tsai
03	August 27, 2024	See the following Note Rev. (03)	P.4, 5, 13	Peggy Tsai
04	August 28, 2024	See the following Note Rev. (04)	P.1, 6	Peggy Tsai

Note:

Rev. (01)

1. Modify date of test in section 1.1.
2. Modify measurement uncertainty in section 1.4.
3. Modify facilities and test location in section 1.5.
4. Modify instrument calibration in section 1.6.
5. Modify note in section 2.
6. Modify the worst mode of measurement in section 3.2.
7. Modify radiation bandedge and spurious emission in section 4.2.
8. Modify appendix-A test photo.

Rev. (02)

1. Add Class IV Permissive Change in section 1.1.

Rev. (03)

1. Modify PMN and Class II Permissive Change in section 1.1.
2. Modify Remark in section 3.2.

Rev. (04)

1. Add Class I Permissive Change in section 1.1.

Table of contents

1.	GENERAL INFORMATION	4
1.1	EUT INFORMATION	4
1.2	EUT CHANNEL INFORMATION	7
1.3	ANTENNA INFORMATION	7
1.4	MEASUREMENT UNCERTAINTY.....	8
1.5	FACILITIES AND TEST LOCATION	8
1.6	INSTRUMENT CALIBRATION	9
1.7	SUPPORT AND EUT ACCESSORIES EQUIPMENT	10
1.8	TEST SETUP DIAGRAM.....	11
1.9	TEST PROGRAM	11
1.10	TEST METHODOLOGY AND APPLIED STANDARDS	11
2.	TEST SUMMARY	12
3.	DESCRIPTION OF TEST MODES.....	13
3.1	THE WORST MODE OF OPERATING CONDITION	13
3.2	THE WORST MODE OF MEASUREMENT	14
4.	TEST RESULT	15
4.1	OUTPUT POWER MEASUREMENT	15
4.2	RADIATION BANDEDGE AND SPURIOUS EMISSION	18
APPENDIX A - PHOTOGRAPHS OF EUT		

1. GENERAL INFORMATION

1.1 EUT INFORMATION

FCC Applicant	Mitac Digital Technology Corporation 4F., No. 1, R&D Road 2, Hsinchu Science Park, Hsinchu 30076 Taiwan
FCC Manufacturer	MITAC COMPUTER (KUNSHAN) CO., LTD. No. 269, 2nd Avenue, District A, Comprehensive Free Trade Zone, Kunshan, Jiangsu, P.R. China
IC Applicant	MiTAC Digital Technology Corporation 4F., No. 1, R&D Road 2, Hsinchu Science Park, Hsinchu 30076 Taiwan
IC Manufacturer	MITAC COMPUTER (KUNSHAN) CO., LTD. No. 269, 2nd Rd, Export Processing Zone Changjiang South Road Kushan, Jiangsu China (Peoples Republic Of)
Equipment	Connected Digital Recorder
Model Name	N702, N702B, CAMPro US, SafetyCam Pro
Model Discrepancy	Difference of the those model number / trademarks (list on this report) are just for marketing purpose only.
Brand Name	MiTAC, Mio, MAGELLAN, Navman, SMARTER AI, Webfleet, Azuga
Received Date	May 31, 2024
Date of Test	July 3 ~ August 13, 2024
Power Supply	Power from power supply. (DC 12~24V)
PMN	Connected Digital Recorder
EUT Serial #	HDR2CE00
HW Version	R03
SW Version	R01

<p>Class II Permissive Change</p>	<p>This is to request for a Re-Assessment (Modification) of the Model Name: N702, FCC ID: P4Q-N702.</p> <p>1. The intention of this application is due to volume of speaker is not loud enough, therefore MiTAC modify speaker to large dimension to increase better experience.</p> <p>MiTAC also add new model and trade mark list as below</p> <table border="1" data-bbox="550 611 1426 712"> <tr> <td data-bbox="550 611 778 678">Brand Name</td> <td data-bbox="778 611 1426 678">MiTAC, Mio, MAGELLAN, Navman, SMARTER AI, Webfleet, Azuga</td> </tr> <tr> <td data-bbox="550 678 778 712">Added Models</td> <td data-bbox="778 678 1426 712">N702, N702B, CAMPro US, SafetyCam Pro</td> </tr> </table> <p>All models are electrically identical (Include: circuitry, components, layout, antenna type and gain, enclosure), different model names are for marketing purpose only.</p> <p>2. Adding the following accessories and cables.</p> <ul style="list-style-type: none"> (1) A60 Camera (2) Panic button (3) AE-CM30HB (TVI camera) (4) AE-CH11A (TVI camera) (5) ODB Transfer Cable (6) Open wire power cable (7) 12V TVI cable (8) OBDII power cable for 12V TVI cable (9) Hardwire power cable for 12V TVI cable (10) Clean installation V.2 cable (11) A60 Power cable (12) Mini USB Relay <p>3. Update HW version to R03.</p>	Brand Name	MiTAC, Mio, MAGELLAN, Navman, SMARTER AI, Webfleet, Azuga	Added Models	N702, N702B, CAMPro US, SafetyCam Pro
	Brand Name	MiTAC, Mio, MAGELLAN, Navman, SMARTER AI, Webfleet, Azuga			
Added Models	N702, N702B, CAMPro US, SafetyCam Pro				

<p>Class I Permissive Change</p>	<p>This is to request for a Re-Assessment (Modification) of the Model Name: N702, IC Certification No: 2420C-N702.</p> <p>1. The intention of this application is due to volume of speaker is not loud enough, therefore MiTAC modify speaker to large dimension to increase better experience.</p> <p>MiTAC also add new model and trade mark list as below</p> <table border="1" style="width: 100%;"> <tr> <td style="width: 30%;">Brand Name</td> <td>MiTAC, Mio, MAGELLAN, Navman, SMARTER AI, Webfleet, Azuga</td> </tr> <tr> <td>Added Models</td> <td>N702, N702B, CAMPro US, SafetyCam Pro</td> </tr> </table> <p>All models are electrically identical (Include: circuitry, components, layout, antenna type and gain, enclosure), different model names are for marketing purpose only.</p> <p>2. Adding the following accessories and cables.</p> <ul style="list-style-type: none"> (1) A60 Camera (2) Panic button (3) AE-CM30HB (TVI camera) (4) AE-CH11A (TVI camera) (5) ODB Transfer Cable (6) Open wire power cable (7) 12V TVI cable (8) OBDII power cable for 12V TVI cable (9) Hardwire power cable for 12V TVI cable (10) Clean installation V.2 cable (11) A60 Power cable (12) Mini USB Relay <p>3. Update HW version to R03.</p>	Brand Name	MiTAC, Mio, MAGELLAN, Navman, SMARTER AI, Webfleet, Azuga	Added Models	N702, N702B, CAMPro US, SafetyCam Pro
	Brand Name	MiTAC, Mio, MAGELLAN, Navman, SMARTER AI, Webfleet, Azuga			
	Added Models	N702, N702B, CAMPro US, SafetyCam Pro			

Remark:

1. For more details, please refer to the User's manual of the EUT.
2. Disclaimer: Antenna information is provided by the applicant, test results of this report are applicable to the sample EUT received.
3. Disclaimer: Variant information between/among model numbers / trademarks is provided by the applicant, test results of this report are applicable to the sample EUT received of main test model name.

1.2 EUT CHANNEL INFORMATION

Frequency Range	2402MHz-2480MHz
Modulation Type	GFSK for BLE 1 Mbps
Number of channels	40 Channels

Remark:

Refer as ANSI C63.10: 2013 clause 5.6.1 Table 4 and RSS-GEN Table 1 for test channels

Number of frequencies to be tested		
Frequency range in which device operates	Number of frequencies	Location in frequency range of operation
<input type="checkbox"/> 1 MHz or less	1	Middle
<input type="checkbox"/> 1 MHz to 10 MHz	2	1 near top and 1 near bottom
<input checked="" type="checkbox"/> More than 10 MHz	3	1 near top, 1 near middle, and 1 near bottom

1.3 ANTENNA INFORMATION

Antenna Specification	<input type="checkbox"/> PIFA <input type="checkbox"/> PCB <input checked="" type="checkbox"/> Dipole <input type="checkbox"/> Coils
Antenna Gain	Gain: 4.2 dBi
Antenna connector	I-PEX

Notes:

1.The antenna(s) of the EUT are permanently attached and there are no provisions for connection to an external antenna. So the EUT complies with the requirements of §15.203 and RSS-Gen 6.8.

Report No.: TMWK2405001767KR

1.4 MEASUREMENT UNCERTAINTY

PARAMETER	UNCERTAINTY
RF output power (Power Meter + Power sensor)	± 0.243 dB
Radiated Emission_9kHz-30MHz	± 3.761 dB
Radiated Emission_30MHz-200MHz	± 3.473 dB
Radiated Emission_200MHz-1GHz	± 3.946 dB
Radiated Emission_1GHz-6GHz	± 4.797 dB

Remark:

- 1.This uncertainty represents an expanded uncertainty expressed at approximately the 95% confidence level using a coverage factor of k=2
2. ISO/IEC 17025 requires that an estimate of the measurement uncertainties associated with the emissions test results be included in the report.

1.5 FACILITIES AND TEST LOCATION

All measurement facilities used to collect the measurement data are located at No.11, Wugong 6th Rd., Wugu Dist., New Taipei City, Taiwan.

CAB identifier: TW1309

Test site	Test Engineer	Remark
Radiation	Ray Li, Tony Chao	-
RF Conducted	David Lee	-

Remark: The lab has been recognized as the FCC accredited lab. under the KDB 974614 D01 and is listed in the FCC public Access Link (PAL) database, FCC Registration No. :444940, the FCC Designation No.:TW1309

Report No.: TMWK2405001767KR

1.6 INSTRUMENT CALIBRATION

Conducted FCC/IC/NCC (All)					
Name of Equipment	Manufacturer	Model	Serial Number	Calibration Date	Calibration Due
Power Supply	GWINSTEK	SPS-3610	GPE880163	2023-11-16	2024-11-15
Power Sensor	Anritsu	MA2411B	1726104	2024-04-16	2025-04-15
Power Sensor	Anritsu	MA2411B	1726107	2024-04-16	2025-04-15
Power Meter	Anritsu	ML2496A	1804001	2024-04-16	2025-04-15
Signal Analyzer	KEYSIGHT	N9030B	MY62291089	2023-10-13	2024-10-12
Software	Radio Test Software Ver. 21				

966A Radiated					
Name of Equipment	Manufacturer	Model	Serial Number	Calibration Date	Calibration Due
Signal Analyzer	KEYSIGHT	N9010A	MY52220817	2024-03-15	2025-03-14
Thermo-Hygro Meter	WISEWIND	1206	D07	2023-12-07	2024-12-06
Active Loop Antenna	SCHWARZBECK	FMZB 1513-60	1513-60-028	2023-12-13	2024-12-12
Bi-Log Antenna	Sunol Sciences	JB1	A052609	2024-02-02	2025-02-01
Preamplifier	EMEC	EM330	060609	2024-02-21	2025-02-20
Cable	Huber+Suhner	104PEA	20995+21000+182330	2024-02-21	2025-02-20
Horn Antenna	ETC	MCTD 1209	DRH13M02003	2023-12-28	2024-12-27
Preamplifier	HP	8449B	3008A00965	2023-12-22	2024-12-21
Cable	EMCI	EMC101G	221213+221011+221012	2023-10-17	2024-10-16
Turn Table	CCS	CC-T-1F	N/A	N.C.R	N.C.R
Controller	CCS	CC-C-1F	N/A	N.C.R	N.C.R
Antenna Tower	CCS	CC-A-1F	N/A	N.C.R	N.C.R
Software	e3 V9-210616c				

Remark:

1. Each piece of equipment is scheduled for calibration once a year.
2. N.C.R. = No Calibration Required.

Report No.: TMWK2405001767KR

1.7 SUPPORT AND EUT ACCESSORIES EQUIPMENT

EUT Accessories Equipment						
No.	Equipment	Brand	Model	Series No.	FCC ID	IC
	N/A					

Support Equipment (Conducted)						
No.	Equipment	Brand	Model	Series No.	FCC ID	IC
1	NB(B)	Lenovo	T470	N/A	N/A	N/A
2	Mini USB	RS Pro	2369084	N/A	N/A	N/A
3	DC Power Cable	MISUMI	MCR3S-RE	N/A	N/A	N/A
A	Main entry cable	N/A	N/A	N/A	N/A	N/A

Support Equipment (RSE)						
No.	Equipment	Brand	Model	Series No.	FCC ID	IC
1	NB(D)	Lenovo	ThinkPad X260	N/A	N/A	N/A
2	Adapter	Lenovo	ADLX45DLC3A	N/A	N/A	N/A
3	Power Supply	ABM	9603D	D011314	N/A	N/A
4	Cable TypeA to TypeC	Silicon-Power	SP BOOST LINK LK10AC	N/A	N/A	N/A
5	DC Cable	MISUMI	MCR3S-RE	N/A	N/A	N/A
A	Micro SD Card	SP	N/A	N/A	N/A	N/A
B	Micro SD Card	SP	N/A	N/A	N/A	N/A
C	12V TVI cable	N/A	N/A	N/A	N/A	N/A
D	OBDII power cable for 12V TVI cable	N/A	N/A	N/A	N/A	N/A
E	Panic button	N/A	Panic button	N/A	N/A	N/A
F	ODB Transfer Cable	N/A	ODB Transfer Cable	N/A	N/A	N/A
G	AE-CH11A (TVI camera)	N/A	AE-CH11A	N/A	N/A	N/A
H	AE-CM30HB (TVI camera)	N/A	AE-CM30HB	N/A	N/A	N/A

1.8 TEST SETUP DIAGRAM

RSE:

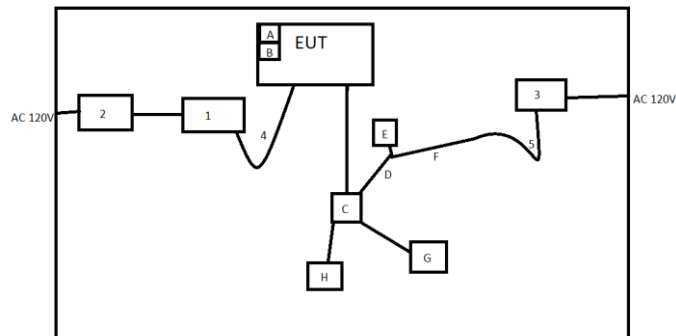

1.9 TEST PROGRAM

The EUT connection corresponds to the surrounding fixture control board. This EUT uses "QRCT4" software to set the frequency, modulation, and power to allow the sample to continuously transmit (including frequency hopping mode).

1.10 TEST METHODOLOGY AND APPLIED STANDARDS

The test methodology, setups and results comply with all requirements in accordance with ANSI C63.10:2013, FCC Part 2, FCC Part 15.247, KDB 558074, RSS-247 Issue 3 and RSS-GEN Issue 5

2. TEST SUMMARY

FCC Standard Section	IC Standard Section	Report Section	Test Item	Result
15.203	RSS-Gen 6.8	1.3	Antenna Requirement	Pass
15.247(b)(3)	RSS-247(5.4)(d)	4.2	Output Power Measurement	Verify
15.247(d) 15.209 15.205	RSS-GEN 8.9, 8.10	4.3	Radiation Spurious Emission	Pass

Verify: Verify RF power and confirm it does not exceed Tune power.

Note: For new changes, adding accessories and replacing speakers do not modify the RF part, so the original RF performance and characteristics are not affected. Therefore, the maximum power mode is selected for verification power. In this mode, the radiation is evaluated 30MHz to 6GHz. For other projects, refer to the original ID. Bring products into compliance.

Report No.: TMWK2405001767KR

3. DESCRIPTION OF TEST MODES

3.1 THE WORST MODE OF OPERATING CONDITION

Operation mode	BLE Mode (1Mbps)
Test Channel Frequencies	1.Lowest Channel : 2402MHz 2.Middle Channel : 2442MHz 3.Highest Channel : 2480MHz

Remark:

1. EUT pre-scanned data rate of output power for each mode, the worst data rate were recorded in this report.

Report No.: TMWK2405001767KR

3.2 THE WORST MODE OF MEASUREMENT

Radiated Emission Measurement Below 1G	
Test Condition	Radiated Emission Below 1G
Power supply Mode	Mode 1: EUT power by Power supply (SD+12V TVI cable+OBDII power cable for 12V TVI cable+ Panic button +ODB Transfer Cable+AE-CH11A (TVI camera)+ AE-CM30HB (TVI camera))
	Mode2: EUT power by Power supply (SD+12V TVI cable+ Hardwire power cabel for 12V TVI cable+ Panic button +ODB Transfer Cable+AE-CH11A (TVI camera)+ AE-CM30HB (TVI camera))
	Mode 3: EUT power by Power supply (SD+Mini USB Relay+A60 Camera+ A60 power cable+ Open wire power cable+ Panic button)
	Mode 4: EUT power by Power supply (SD+Mini USB Relay+A60 Camera+ A60 power cable+ Clean installation V.2 cable + ODB Transfer Cable + Panic button)
Worst Mode	<input checked="" type="checkbox"/> Mode 1 <input type="checkbox"/> Mode 2 <input type="checkbox"/> Mode 3 <input type="checkbox"/> Mode 4

Radiated Emission Measurement Above 1G	
Test Condition	Radiated Emission Above 1G
Power supply Mode	Mode 1: EUT power by Power supply (SD+12V TVI cable+OBDII power cable for 12V TVI cable+ Panic button +ODB Transfer Cable+AE-CH11A (TVI camera)+ AE-CM30HB (TVI camera))
Worst Mode	<input checked="" type="checkbox"/> Mode 1 <input type="checkbox"/> Mode 2 <input type="checkbox"/> Mode 3 <input type="checkbox"/> Mode 4

Remark:

1. The worst mode was record in this test report.
2. EUT pre-scanned in three axis ,X,Y, Z and two polarity, for radiated measurement. The worst case(Y-Plane) were recorded in this report
3. The device supports 12V or 24V. The original ID has been fully evaluated as 12V as the worst mode. In this accessory combination, 12V is used as the worst mode evaluation.
4. Variations between models/brands are evaluated by laboratories and the test results reported here apply to the worst model: N702B.

Report No.: TMWK2405001767KR

4. TEST RESULT

4.1 OUTPUT POWER MEASUREMENT

4.1.1 Test Limit

According to §15.247(b)(3) and RSS-247 section 5.4(d)

Peak output power :

FCC

For systems using digital modulation in the 902-928 MHz, 2400-2483.5 MHz, and 5725-5850 MHz bands: 1 Watt.

IC

For DTSs employing digital modulation techniques operating in the bands 902-928 MHz and 2400-2483.5 MHz, the maximum peak conducted output power shall not exceed 1 W. The e.i.r.p. shall not exceed 4 W, except as provided in section 5.4(e), base on the use of antennas with directional gain not exceed 6 dBi If transmitting antennas of directional gain greater than 6dBi are used the peak output power the conducted output power from the intentional radiator shall be reduced by the amount in dB that the directional gain of the antenna exceeds 6 dBi. In case of point-to-point operation, the limit has to be reduced by 1dB for every 3 dB that the directional gain of the antenna exceeds 6 dBi.

Limit	<input checked="" type="checkbox"/> Antenna not exceed 6 dBi : 30dBm <input type="checkbox"/> Antenna with DG greater than 6 dBi [Limit = 30 – (DG – 6)] <input type="checkbox"/> Point-to-point operation
-------	---

Average output power : For reporting purposes only.

4.1.2 Test Procedure

Test method Refer as KDB 558074 D01 and ANSI C63.10:2013.

1. The EUT RF output connected to the power meter by RF cable.
2. Setting maximum power transmit of EUT.
3. The path loss was compensated to the results for each measurement.
4. Measure and record the result of Peak output power and Average output power. in the test report.

4.1.3 Test Setup

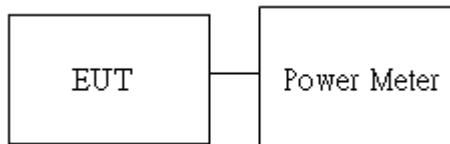

Report No.: TMWK2405001767KR

4.1.4 Test Result

Temperature: 23.6°C Test date: July 3, 2024
Humidity: 55% RH Tested by: David Lee

Peak & Average output power :

BLE 1M mode:

CH	Frequency (MHz)	Peak Output Power (dBm)	Required Limit (dBm)
Low	2402	0.17	30
Mid	2442	-0.80	30
High	2480	0.46	30
CH	Frequency (MHz)	Avg. Output Power (dBm)	Required Limit (dBm)
Low	2402	0.01	30
Mid	2442	-0.94	30
High	2480	0.34	30

***Note:**

1. Measured by power meter, cable loss dB + Duty cycle factor has been offsetted to the power meter for Avg. power and cable loss has been offsetted for Peak power measurement.

EIRP power :

EIRP BLE 1M mode

CH	Frequency (MHz)	Avg. Output Power (dBm)	Antenna Gain (dBi)	EIRP (dBm)	Limit
Low	2402	0.01	4.20	4.21	4W= 36 dBm
Mid	2442	-0.94	4.20	3.26	4W= 36 dBm
High	2480	0.34	4.20	4.54	4W= 36 dBm

*** Note:** EIRP = Average Power + Gain

Report No.: TMWK2405001767KR

4.2 RADIATION BANDEDGE AND SPURIOUS EMISSION

4.2.1 Test Limit

FCC according to §15.247(d), §15.209 and §15.205,

In any 100 kHz bandwidth outside the authorized frequency band, all harmonic and spurious must be least 20 dB below the highest emission level with the authorized frequency band. Radiation emission which fall in the restricted bands must also follow the FCC section 15.209 as below limit in table.

Below 30 MHz

Frequency	Field Strength (microvolts/m)	Magnetic H-Field (microamperes/m)	Measurement Distance (metres)
9-490 kHz	2,400/F (F in kHz)	2,400/F (F in kHz)	300
490-1,705 kHz	24,000/F (F in kHz)	24,000/F (F in kHz)	30
1.705-30 MHz	30	N/A	30

Above 30 MHz

Frequency (MHz)	Field Strength microvolts/m at 3 metres (watts, e.i.r.p.)	
	Transmitters	Receivers
30-88	100 (3 nW)	100 (3 nW)
88-216	150 (6.8 nW)	150 (6.8 nW)
216-960	200 (12 nW)	200 (12 nW)
Above 960	500 (75 nW)	500 (75 nW)

Remark:

Although these tests were performed other than open area test site, adequate comparison measurements were confirmed against 30 m open area test site. Therefore sufficient tests were made to demonstrate that the alternative site produces results that correlate with the ones of tests made in an open field based on KDB 414788.

Report No.: TMWK2405001767KR

IC according to RSS-247 section 5.5, RSS-Gen, Section 8.9 and 8.10

RSS-Gen Table 3 and Table 5 – General Field Strength Limits for Transmitters and Receivers at Frequencies Above 30 MHz ^(Note)

Frequency (MHz)	Field Strength microvolts/m at 3 metres (watts, e.i.r.p.)	
	Transmitters	Receivers
30-88	100 (3 nW)	100 (3 nW)
88-216	150 (6.8 nW)	150 (6.8 nW)
216-960	200 (12 nW)	200 (12 nW)
Above 960	500 (75 nW)	500 (75 nW)

Note: Measurements for compliance with the limits in table 3 may be performed at distances other than 3 metres, in accordance with Section 6.6.

RSS-Gen Table 6: General Field Strength Limits for Transmitters at Frequencies Below 30 MHz (Transmit)

Frequency	Magnetic field strength (H-Field) ($\mu\text{A/m}$)	Measurement Distance (m)
9-490 kHz ^{Note}	6.37/F (F in kHz)	300
490-1,705 kHz	63.7/F (F in kHz)	30
1.705-30 MHz	0.08	30

Note: The emission limits for the ranges 9-90 kHz and 110-490 kHz are based on measurements employing a linear average detector.

Report No.: TMWK2405001767KR

4.2.2 Test Procedure

1. The EUT is placed on a turntable, Above 1 GHz is 1.5m and below 1 GHz is 0.8m above ground plane. The EUT Configured un accordance with ANSI C63.10: 2013, and the EUT set in a continuous mode.
2. The turntable shall be rotated for 360 degrees to determine the position of maximum emission level. And EUT is set 3m away from the receiving antenna, which is scanned from 1m to 4m above the ground plane to find out the highest emissions. Measurement are made polarized in both the vertical and the horizontal positions with antenna.
3. Span shall wide enough to full capture the emission measured. The SA from 9KHz to 1GHz set to the max power channels with the EUT transmit.
4. No emission found between lowest internal used/generated frequency to 30MHz (9KHz~30MHz).

Radiated emission below 30MHz is measured in a 9m*6m*6m semi-ane choic chamber, the measurements correspond to those obtained at an open-field test site. There is a comparison data of both open-field test site and semi-Anechoic chamber, and the result came out very similar.

5. The SA setting following :

(1) Below 30MHz :

(1.1) 9KHz-490KHz : RBW=200Hz / VBW=1kHz / Sweep=AUTO

(1.2) 490KHz-30MHz : RBW=10kHz / VBW=30kHz / Sweep=AUTO

(2) 30MHz to 1GHz : RBW = 100kHz, VBW \geq 3*RBW, Sweep = Auto,

Detector = Peak, Trace = Max hold.

(3) Above 1G :

(2.1) For Peak measurement : RBW = 1MHz, VBW \geq 3 RBW, Sweep = Auto,
Detector = Peak, Trace = Max hold.

(2.2) For Average measurement : RBW = 1MHz, VBW

·If Duty Cycle \geq 98%, VBW=10Hz.

·If Duty Cycle < 98%, VBW \geq 1/T.

6. Data result :

Actual FS=Spectrum Reading Level + Factor

Margin=Actual FS- Limit

4.2.3 Test Setup

9kHz ~ 30MHz

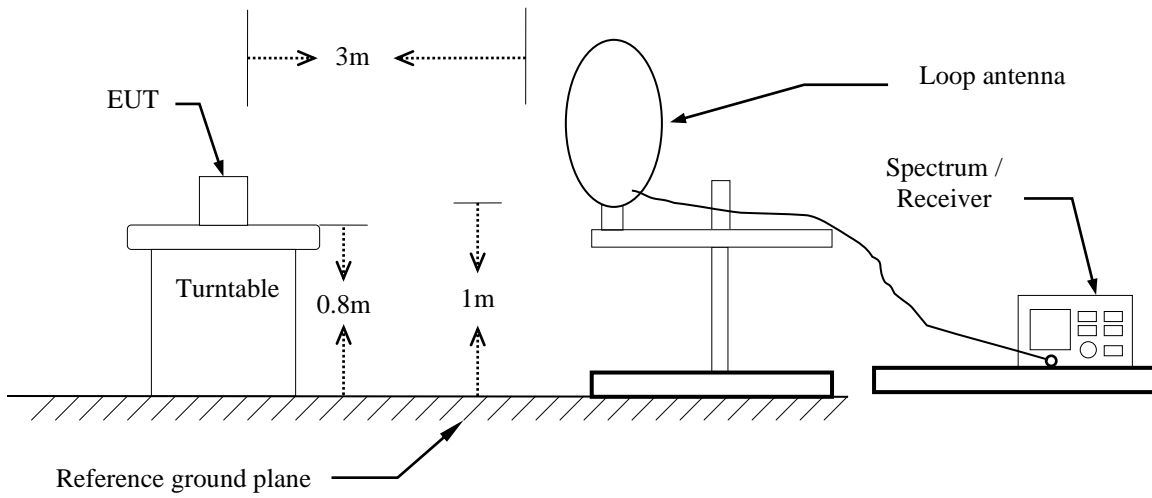

30MHz ~ 1GHz

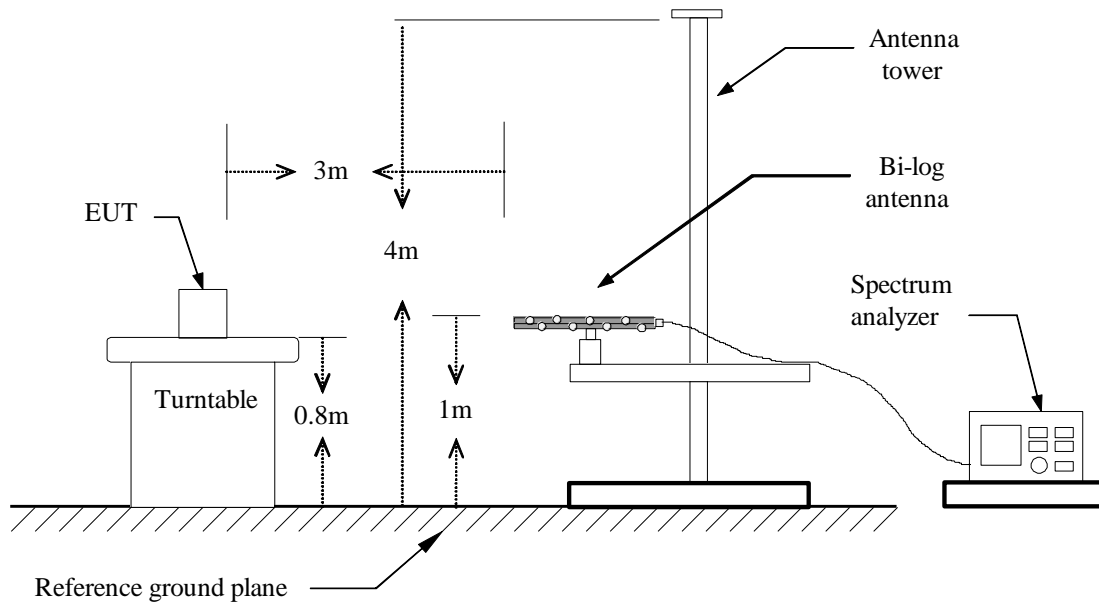

Above 1 GHz

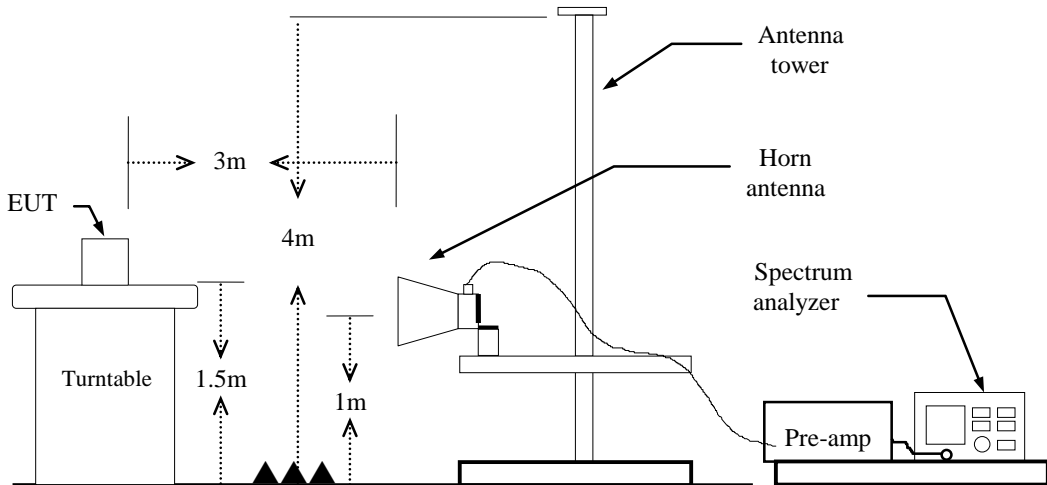

Report No.: TMWK2405001767KR

4.2.4 Test Result

Project No	:TM-2405000397P	Test Date	:2024-07-12
Operation Band	:BLE 1M	Temp./Humi.	:23.9/55
Frequency	:2442 MHz	Antenna Pol.	:VERTICAL
Operation Mode	:TX	Engineer	:Ray.Li
EUT Pol	:E1	Test Chamber	: 966A
Setting	:		

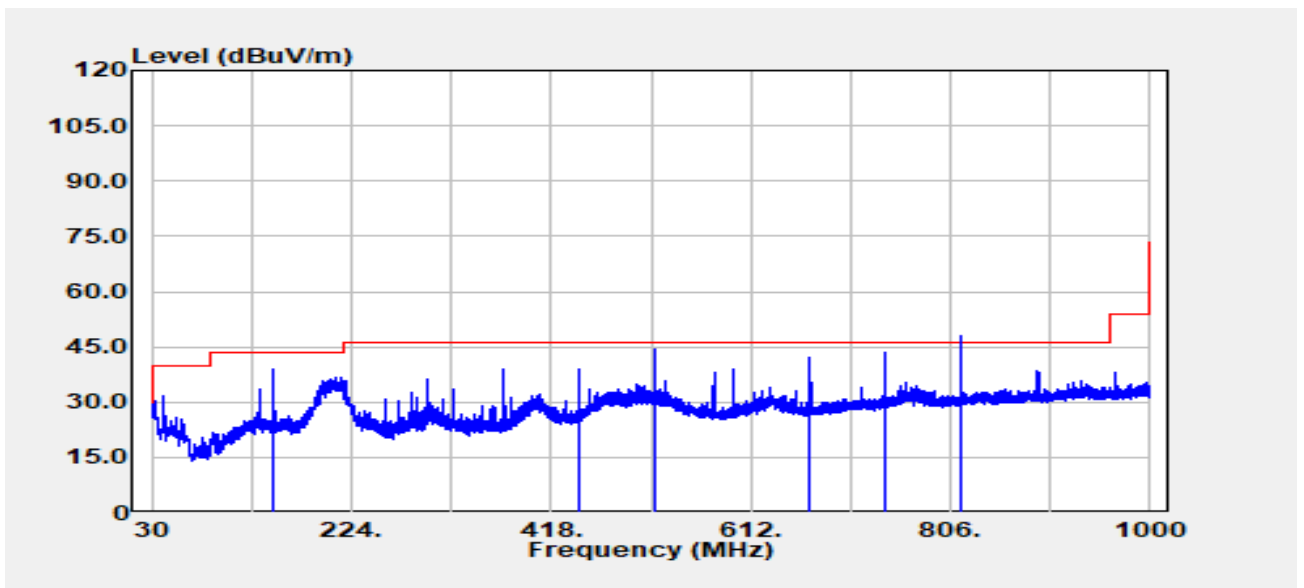

Freq. MHz	Detector Mode PK/QP/AV	Spectrum Read Level dB μ V	Factor dB	Actual FS dB μ V/m	Limit dB μ V/m	Margin dB
148.50	Peak	49.17	-10.43	38.74	43.50	-4.76
445.50	Peak	43.24	-4.27	38.97	46.00	-7.03
519.80	Peak	47.17	-2.75	44.43	46.00	-1.57
668.30	Peak	42.57	-0.32	42.24	46.00	-3.76
742.50	Peak	42.42	1.17	43.59	46.00	-2.41
816.80	QP	43.22	2.54	45.76	46.00	-0.24

Report No.: TMWK2405001767KR

Project No :TM-2405000397P
 Operation Band :BLE 1M
 Frequency :2442 MHz
 Operation Mode :TX
 EUT Pol :E1
 Setting :

Test Date :2024-07-12
 Temp./Humi. :23.9/55
 Antenna Pol. :HORIZONTAL
 Engineer :Ray.Li
 Test Chamber : 966A

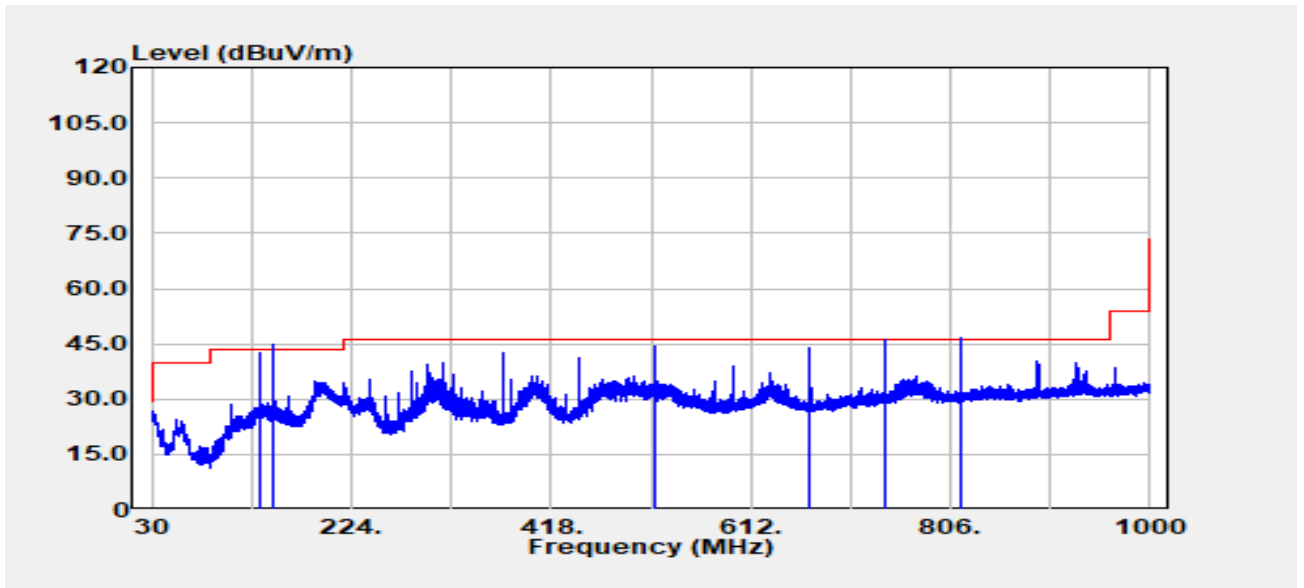

Freq. MHz	Detector Mode PK/QP/AV	Spectrum Read Level dBuV	Factor dB	Actual FS dBuV/m	Limit dBuV/m	Margin dB
135.00	Peak	51.62	-9.14	42.48	43.50	-1.02
148.50	QP	53.35	-10.43	42.92	43.50	-0.58
519.80	Peak	47.25	-2.75	44.50	46.00	-1.50
668.30	Peak	44.41	-0.32	44.09	46.00	-1.91
742.50	QP	43.02	1.17	44.19	46.00	-1.81
816.80	QP	42.12	2.54	44.66	46.00	-1.34

Report No.: TMWK2405001767KR

Project No	:TM-2405000397P	Test Date	:2024-08-13
Operation Band	:BLE_1M	Temp./Humi.	:24.6/57
Frequency	:2442 MHz	Antenna Pol.	:VERTICAL
Operation Mode	:TX	Engineer	:Tony.Chao
EUT Pol	:E1	Test Chamber	: 966A
Setting	:		

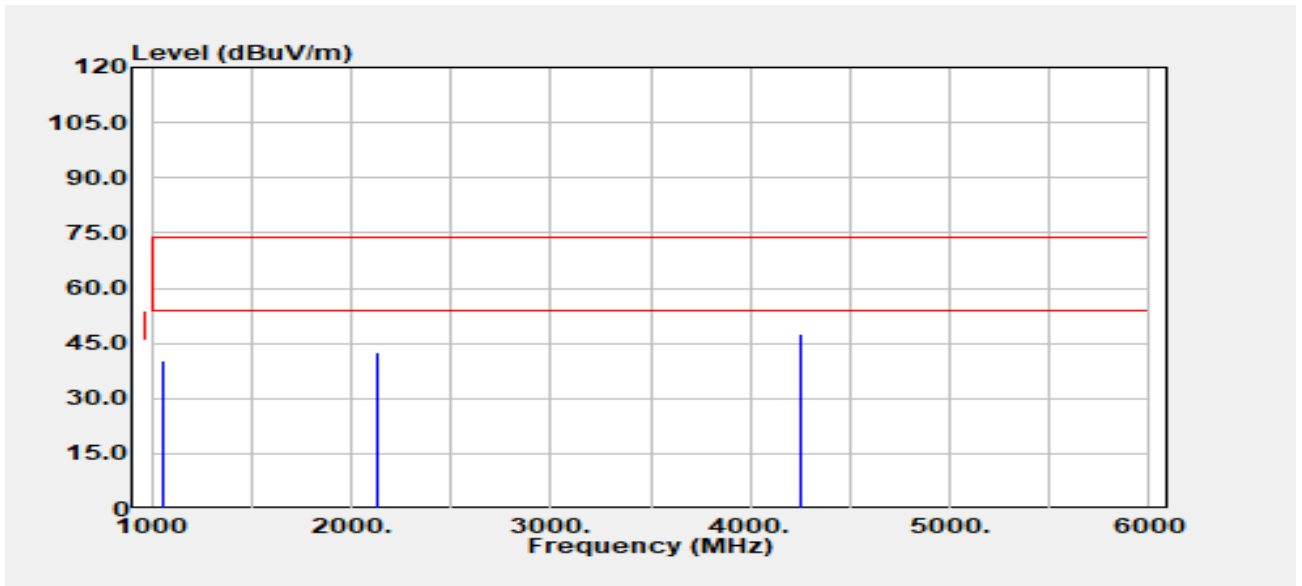

Freq. MHz	Detector Mode PK/QP/AV	Spectrum Read Level dBuV	Factor dB	Actual FS dBuV/m	Limit dBuV/m	Margin dB
1063.24	Peak	49.54	-9.34	40.20	74.00	-33.80
2132.94	Peak	45.21	-2.60	42.62	74.00	-31.38
4247.06	Peak	46.52	1.23	47.75	74.00	-26.25

Report No.: TMWK2405001767KR

Project No :TM-2405000397P
 Operation Band :BLE_1M
 Frequency :2442 MHz
 Operation Mode :TX
 EUT Pol :E1
 Setting :

Test Date :2024-08-13
 Temp./Humi. :24.6/57
 Antenna Pol. :HORIZONTAL
 Engineer :Tony.Chao
 Test Chamber : 966A

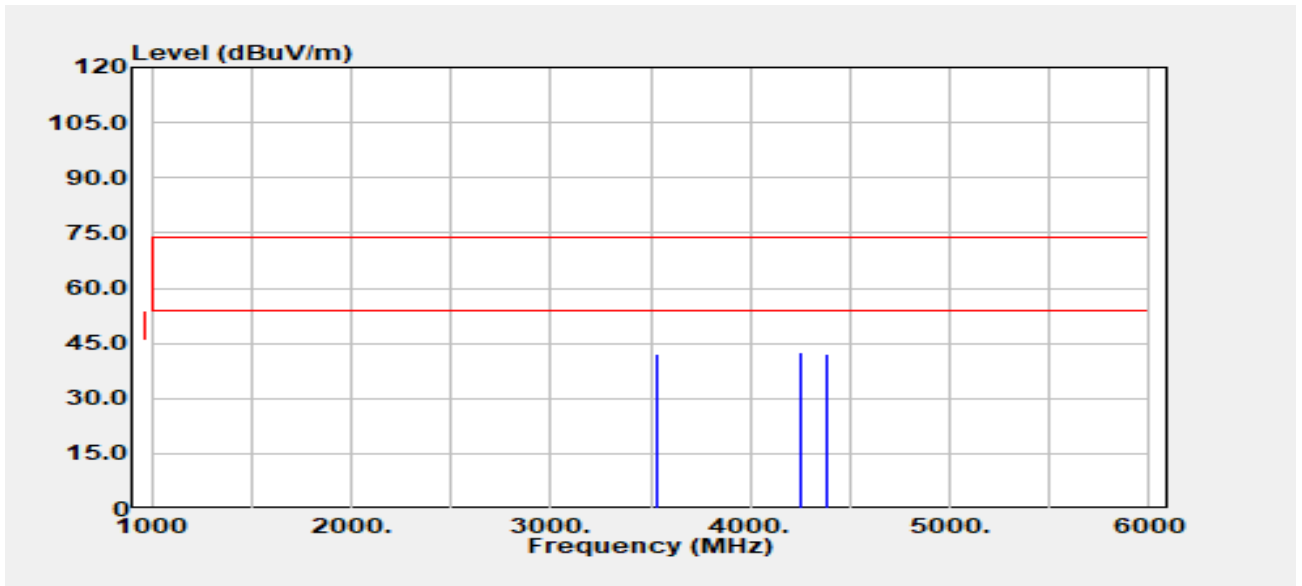

Freq. MHz	Detector Mode PK/QP/AV	Spectrum Read Level dBuV	Factor dB	Actual FS dBuV/m	Limit dBuV/m	Margin dB
3532.06	Peak	42.90	-0.78	42.13	74.00	-31.87
4253.24	Peak	41.27	1.26	42.53	74.00	-31.47
4385.88	Peak	40.19	2.00	42.19	74.00	-31.81

--End of Test Report--