



FCC/IC TEST REPORT

According to
CFR47 §15.247&RSS-247 Issue 2

Applicant : Mitac Digital Technology Corporation
Address : No. 200, Wen Hwa 2nd Rd., Kuei Shan Dist. 33383 Taoyuan City, TAIWAN
Manufacturer : Mitac Computer (Kunshan) Co., Ltd.
Address : No. 269, 2nd Avenue, District A, Comprehensive Free Trade Zone, 215300
Kunshan, Jiangsu, PEOPLES REPUBLIC OF CHINA
Equipment : Tablet
Model No. : N642
FCC ID : P4Q-N642-M1005
IC : 2420C-N642-M1005
Test Period : July 25, 2019~August 15, 2019

- The test result refers exclusively to the test presented test model / sample.
- Without written approval of **Cerpass Technology (Suzhou) Co., Ltd.**, the test report shall not be reproduced except in full.
- The test report must not be used by the clients to claim product certification approval by any agency of the Government.

I **HEREBY** CERTIFY THAT :

The measurements shown in this test report were made in accordance with the procedures given in **ANSI C63.10 – 2013 & FCC Part15.247 & RSS-247 Issue 2** and the energy emitted by this equipment was **passed**.

Approved by:

Miro Chueh
EMC/RF Manager

Laboratory Accreditation:

Cerpass Technology Corporation Test Laboratory



TAF LAB Code: 1439

Cerpass Technology (SuZhou) Co., Ltd.



A2LA LAB Code: 4981.01



Contents

1. Test Configuration of Equipment under Test	5
1.1 Feature of Equipment under Test.....	5
1.2 Description of Antenna.....	5
1.3 Working Frequencies	6
1.4 Power Parameter Value	7
1.5 The Worst Transmission Mode	8
1.6 Duty Cycle.....	9
1.7 Test Manner	10
2. Technical Test	11
2.1 Summary of Test Result.....	11
2.2 General Information of Test.....	12
2.3 Measuring Equipment.....	13
2.4 Measurement Uncertainty.....	14
3. AC Conducted Emission Measurement	15
3.1 Test Limit.....	15
3.2 Test Standard	15
3.3 Test Procedures	15
3.4 Test Setup Layout	16
3.5 Test Result	17
4. Radiated Emission Measurement	25
4.1 Test Limit.....	25
4.2 Test Standard	25
4.3 Test Procedures.....	26
4.4 Test Setup Layout.....	27
4.5 Test Result	29
5. 6dB Bandwidth Measurement	39
5.1 Test Limit.....	39
5.2 Test Standard	39
5.3 Test Procedures	39
5.4 Test Setup Layout	39
5.5 Test Result	40
6. Conducted Output Power Measurement	41
6.1 Test Limit.....	41
6.2 Test Standard	41
6.3 Test Procedures	41
6.4 Test Setup Layout	41
6.5 Test Result	42
7. Power Spectral Density Measurement	43
7.1 Test Limit.....	43
7.2 Test Standard	43
7.3 Test Procedures	43
7.4 Test Setup Layout	43



7.5 Test Result	44
8. Conducted Band Edge and Out-of-Band Emissions Measurement	45
8.1 Test Limit	45
8.2 Test Standard	45
8.3 Test Procedures	46
8.4 Test Setup Layout	46
8.5 Test Result	47
9. Radiated Emission Band Edge Measurement	50
9.1 Test Limit	50
9.2 Test Standard	50
9.3 Test Procedure	50
9.4 Test Setup Layout	51
9.5 Test Result	52



History of this Test Report

Report No.	Version	Issue Date	Description
SEFB1907033-A	Rev 01	Aug. 16, 2019	Original



1. Test Configuration of Equipment under Test

1.1 Feature of Equipment under Test

EUT Type	Tablet	
Model Name	N642	
Wireless Module	Qualcomm WCN3660B	
TX Frequency Range	2.4GHz: 2400MHz ~ 2483.5MHz	
Number of Channel	2.4GHz BT-BDR(GFSK): 79, BT-EDR(Pi/4 DQPSK): 79, BT-EDR(8DPSK): 79 BT-LE(GFSK): 40 802.11b/g, 802.11n-HT20 : 13 802.11n-HT40: 9	
Type of Modulation	BT-BDR(GFSK), BT-EDR(Pi/4 DQPSK), BT-EDR(8DPSK) for FHSS BT-LE (GFSK) for DTS DBPSK, DQPSK, CCK for DSSS in 802.11b mode BPSK, QPSK, 16-QAM, 64-QAM for OFDM in 802.11g/n mode	
Data Rate	BT-BDR(GFSK): 1Mbps, BT-EDR(Pi/4 DQPSK): 2Mbps, BT-EDR(8DPSK) : 3Mbps, BT-LE(GFSK): 1Mbps 802.11b: up to 11Mbps, 802.11g: up to 54Mbps, 802.11n: up to MCS7	
Antenna Type	IFA	
Antenna Peak Gain	2.4~2.4835GHz: 4.35dBi	
Device Category	Portable	
RF Exposure Environment	General Population/ Uncontrolled	
Power supply1	Model:	CVW120200
	Input:	100-240V~1.2A 50-60Hz 0.75A
	Output:	DC 12V --2.0A
Power supply2	Model:	POE-GTI-3556ND4
	Input:	100-240V
	Output:	DC 56V--0.625A

1.2 Description of Antenna

Manufacturer	Model	Specification
Awan	MIC-N642 Locking WIFI	IFA Antenna for WIFI 802.11 a/b/g application



1.3 Working Frequencies

Bluetooth Working Frequency of Each Channel: (For V4.2)							
Channel	Frequency	Channel	Frequency	Channel	Frequency	Channel	Frequency
00	2402 MHz	01	2404 MHz	02	2406 MHz	03	2408 MHz
04	2410 MHz	05	2412 MHz	06	2414 MHz	07	2416 MHz
08	2418 MHz	09	2420 MHz	10	2422 MHz	11	2424 MHz
12	2426 MHz	13	2428 MHz	14	2430 MHz	15	2432 MHz
16	2434 MHz	17	2436 MHz	18	2438 MHz	19	2440 MHz
20	2442 MHz	21	2444 MHz	22	2446 MHz	23	2448 MHz
24	2450 MHz	25	2452 MHz	26	2454 MHz	27	2456 MHz
28	2458 MHz	29	2460 MHz	30	2462 MHz	31	2464 MHz
32	2466 MHz	33	2468 MHz	34	2470 MHz	35	2472 MHz
36	2474 MHz	37	2476 MHz	38	2478 MHz	39	2480 MHz



1.4 Power Parameter Value

Mode	Frequency (MHz)	Power Setting
BLE	2402	Default
	2440	Default
	2480	Default



1.5 The Worst Transmission Mode

Test Mode
Mode 1: Transmit by BLE(GFSK) 1Mbps



1.6 Duty Cycle

Test Item	Duty cycle
-----------	------------

Mode	Frequency (MHz)	Measurement (%)
BLE	2440	62.90

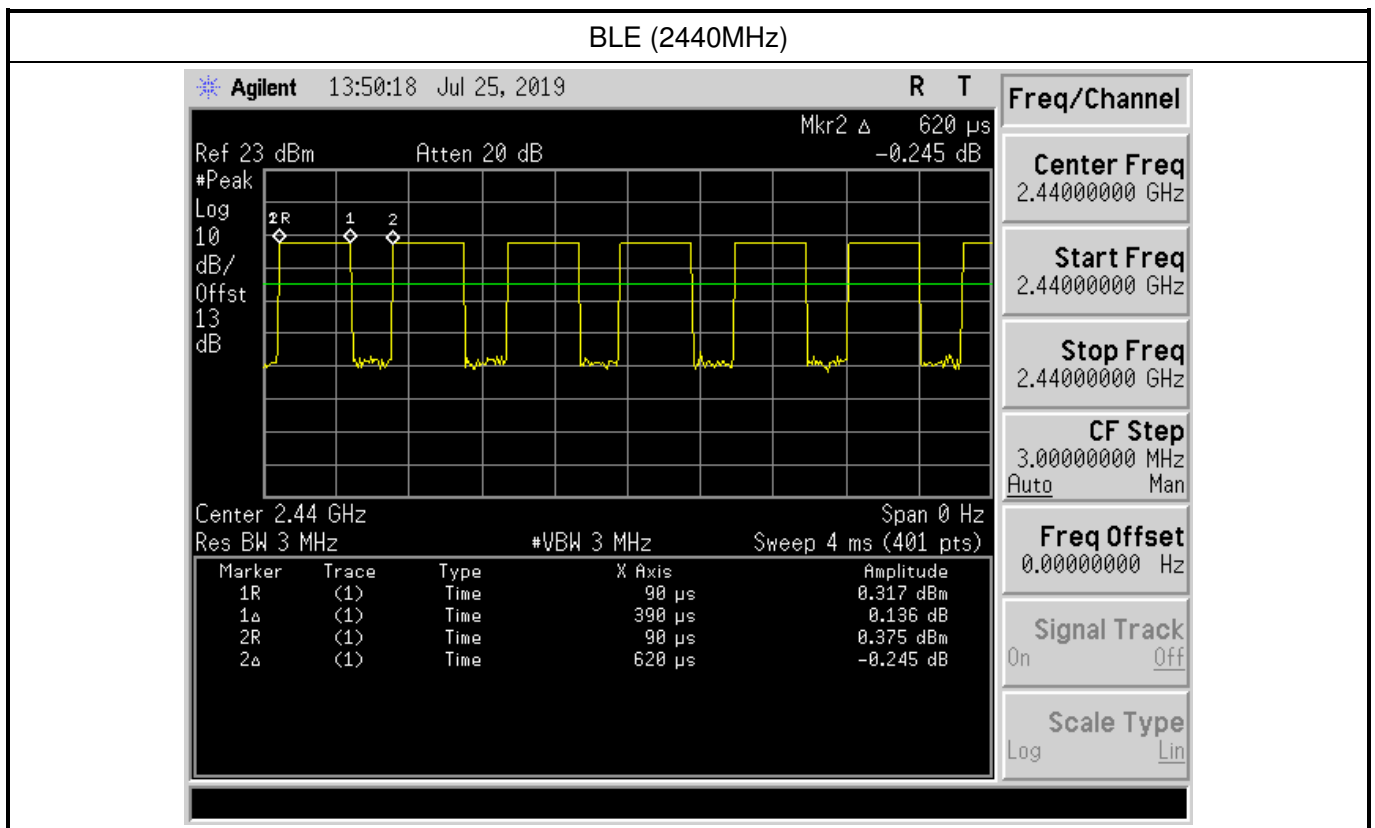



1.7 Test Manner

Test Manner	
a	Setup the EUT and simulators according to ANSI C63.10
b	Turn on the power of equipment.
c	Access the test software, set the test mode and test channel, then start to test.

Note: Regards to the frequency band operation: the lowest, middle and highest frequency of channel were selected to perform the test, then shown on this report.



2. Technical Test

2.1 Summary of Test Result

- No deviations from the test standards
 Deviations from the test standards as below description:

FCC/IC Part Section(s)	Test Description	Test Result
FCC CFR Title 47 Part 15 Subpart C: 2019 Section 15.207 RSS-Gen Issue 4 November 2014 Section 8.8	Conducted Emission	Compliance
FCC CFR Title 47 Part 15 Subpart C: 2019 Section 15.209 RSS-Gen Issue 4 November 2014 Section 8.9	Radiated Emission	Compliance
FCC CFR Title 47 Part 15 Subpart C: 2019 Section 15.247(d) RSS-247 Issue 2 February 2017 Section 5.5	RF Antenna Conducted Spurious	Compliance
FCC CFR Title 47 Part 15 Subpart C: 2019 15.247(d) RSS-247 Issue 2 February 2017 Section 5.5	Radiated Emission Band Edge	Compliance
FCC CFR Title 47 Part 15 Subpart C: 2019 15.215(c)	Operation Frequency Range of 20dB Bandwidth	Compliance
FCC CFR Title 47 Part 15 Subpart C: 2019 Section 15.247(a)(2) RSS-247 Issue 2 February 2017 Section 5.2(a)	Occupied Bandwidth	Compliance
FCC CFR Title 47 Part 15 Subpart C: 2019 Section 15.247(b)(3) RSS-247 Issue 2 February 2017 Section 5.4(d)	Output Power	Compliance
FCC CFR Title 47 Part 15 Subpart C: 2019 Section 15.247(e) RSS-247 Issue 2 February 2017 Section 5.2(b)	Power Spectral Density	Compliance



2.2 General Information of Test

<input type="checkbox"/>	Test Site	Cerpess Technology Corporation Test Laboratory Address: No.10, Ln. 2, Lianfu St., Luzhu Dist., Taoyuan City 33848, Taiwan (R.O.C.) Tel:+886-3-3226-888 Fax:+886-3-3226-881 Address: No.68-1, Shihbachongsi, Shihding Township, New Taipei City 223, Taiwan, R.O.C. Tel: +886-2-2663-8582
	TAF	1439
	FCC	TW1079, TW1061
	IC	4934E-1, 4934E-2
	VCCI	T-2205 for Telecommunication Test C-4663 for Conducted emission test R-4399, R-4218 for Radiated emission test G-812, G-813 for radiated disturbance above 1GHz
<input checked="" type="checkbox"/>	Test Site	Cerpess Technology (Suzhou) Co.,Ltd Address: No.66,Tangzhuang Road, Suzhou Industrial Park, Jiangsu 215006, China Tel: +86-512-6917-5888 Fax: +86-512-6917-5666
	CNAS	L5515
	FCC	CN1243
	A2LA	4981.01
	IC	7290A-1, 7290A-2
	VCCI	T-1945 for Telecommunication Test C-12919 for Conducted emission test R-12670 for Radiated emission test G-227 for radiated disturbance above 1GHz



2.3 Measuring Equipment

Instrument/Ancillary	Manufacturer	Model No.	Serial No.	Calibration Date	Due Date.
EMI Test Receiver	R&S	ESCI	101183	2019.06.28	2020.06.27
Preamplifier	HP	8447F	3113A05915	2019.02.25	2020.02.24
Preamplifier	FIELD	AFS44-00101800 -25-10P-44	1579008	2018.10.14	2019.10.13
Bilog Antenna	Sunol Science	JB1	A072414-1	2019.06.26	2020.06.26
Spectrum Analyzer	Agilent	N9010A	MY45118947	2018.10.11	2019.10.10
Temperature/ Humidity Meter	mingle	ETH529	N/A	2019.02.25	2020.02.24
Spectrum Analyzer	R&S	FSP40	100047	2019.03.07	2020.03.06
PREAMPLIFIER	AGILENT	8449B	3008A01954	2019.03.05	2020.03.04
HORN ANTENNA	EMCO	3115	31589	2019.03.09	2020.03.08
HIGH PASS FILTER	HP	84300-80038	002	2019.03.05	2020.03.04
SERIES POWER METER	ANRITSU	ML2495A	1224005	2019.03.05	2020.03.04
POWER SENSOR	ANRITSU	MA2411B	1207295	2019.03.05	2020.03.04
Bluetooth Tester	R&S	CBT	101133	2019.03.12	2020.03.11



2.4 Measurement Uncertainty

ISO/IEC 17025 requires that an estimate of the measurement uncertainties associated with the emissions test results be included in the report. The measurement uncertainties given below are based on a 95% confidence level (based on a coverage factor (k=2)).

RF Conducted Measurement

Test Item	Uncertainty	Limit	
Radio Frequency	$\pm 8.7 \times 10^{-7}$	$\pm 1 \times 10^{-5}$	
RF output power, conducted	$\pm 0.63 \text{ dB}$	$\pm 1.5 \text{ dB}$	
Power density, conducted	$\pm 1.21 \text{ dB}$	$\pm 3 \text{ dB}$	
Unwanted emissions, conducted	30-1000MHz	$\pm 0.51 \text{ dB}$	$\pm 3 \text{ dB}$
	1-25GHz	$\pm 0.67 \text{ dB}$	$\pm 3 \text{ dB}$
All emissions, radiated	30-1000MHz	$\pm 2.28 \text{ dB}$	$\pm 6 \text{ dB}$
	1-25GHz	$\pm 2.59 \text{ dB}$	$\pm 6 \text{ dB}$
Temperature	$\pm 0.8^\circ \text{C}$	$\pm 1^\circ \text{C}$	
Humidity	$\pm 3\%$	$\pm 5\%$	
DC and low frequency voltages	$\pm 3\%$	$\pm 3\%$	

AC Conducted Measurement

Measurement	Frequency	Uncertainty
Conducted emissions(LINE)	9KHz-30MHz	+/- 0.7738 dB
Conducted emissions(NEUTRAL)	9KHz-30MHz	+/- 0.7886 dB
Conducted emissions(10Mbps)	150KHz-30MHz	+/- 1.3013dB
Conducted emissions(100Mbps)	150KHz-30MHz	+/- 1.3197 dB
Conducted emissions(1000Mbps)	150KHz-30MHz	+/- 1.2987 dB

Radiated Measurement

Measurement	Polarity	Frequency	Uncertainty
Radiated emissions	Horizontal	below 1GHz	+/- 3.8936 dB
	Vertical	below 1GHz	+/- 3.8928 dB
	Horizontal	above 1GHz	+/- 5.18858dB
	Vertical	above 1GHz	+/- 5.18928 dB



3. AC Conducted Emission Measurement

3.1 Test Limit

Conducted Emissions were measured from 150 kHz to 30 MHz with a bandwidth of 9 KHz on the 120 VAC power and return leads of the EUT according to the methods defined in ANSI C63.10-2013 Section 6.2. The EUT was placed on a nonmetallic stand in a shielded room 0.8 meters above the ground plane as shown in section 6.2.2. The interface cables and equipment positioning were varied within limits of reasonable applications to determine the position produced maximum conducted emissions.

FCC Part 15 Subpart C Paragraph 15.207 Limits		
Frequency (MHz)	Quasi Peak (dB μ V)	Average (dB μ V)
0.15 – 0.5	66-56*	56-46*
0.5 – 5.0	56	46
5.0 – 30.0	60	50

*Decreases with the logarithm of the frequency.

3.2 Test Standard

Tested according to ANSI C63.10: 2013 Section 6.2 for compliance to FCC 47CFR 15.247 Part15.207 (a) requirements.

3.3 Test Procedures

The EUT was placed on a platform of nominal size, 1 m by 1.5 m, raised 80 cm above the conducting ground plane. The vertical conducting plane was located 40 cm to the rear of the EUT. All other surfaces of EUT were at least 80 cm from any other grounded conducting surface. The EUT and simulators are connected to the main power through a line impedance stabilization network (LISN). The LISN provides a 50 ohm /50uH coupling impedance for the measuring equipment. The peripheral devices are also connected to the main power through a LISN. (Please refer to the block diagram of the test setup and photographs) Each current-carrying conductor of the EUT power cord, except the ground (safety) conductor, was individually connected through a LISN to the input power source.

The excess length of the power cord between the EUT and the LISN receptacle were folded back and forth at the center of the lead to form a bundle not exceeding 40 cm in length.

Conducted emissions were investigated over the frequency range from 0.15MHz to 30MHz using a receiver bandwidth of 9 kHz.



3.4 Test Setup Layout

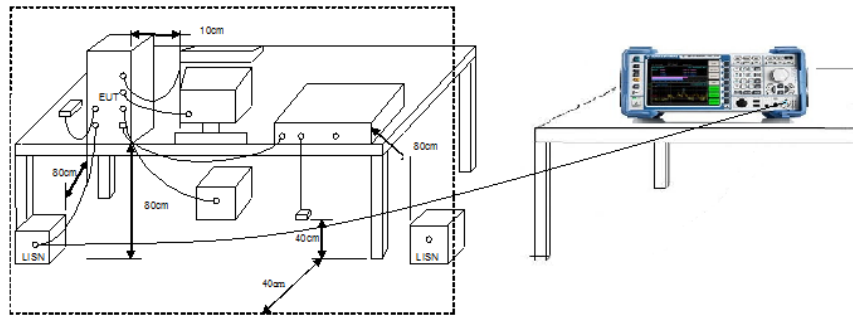



3.5 Test Result

Test Standard:	FCC_ClassB_QP	Probe:	L1
Test item:	Conduction Emission	Test Time:	2019/8/139:52:13
Applicant:	Mitac Digital Technology Company	Power Rating:	AC 120V/60Hz
Product:	Tablet	Temp.(C)/Hum.(%)/Air p.(hpa):	26(°C)/60%/1000hpa
Model No.:	N642	Test Engineer:	Chris
Test Mode:	BLE		
Remark:	Adapter Power		

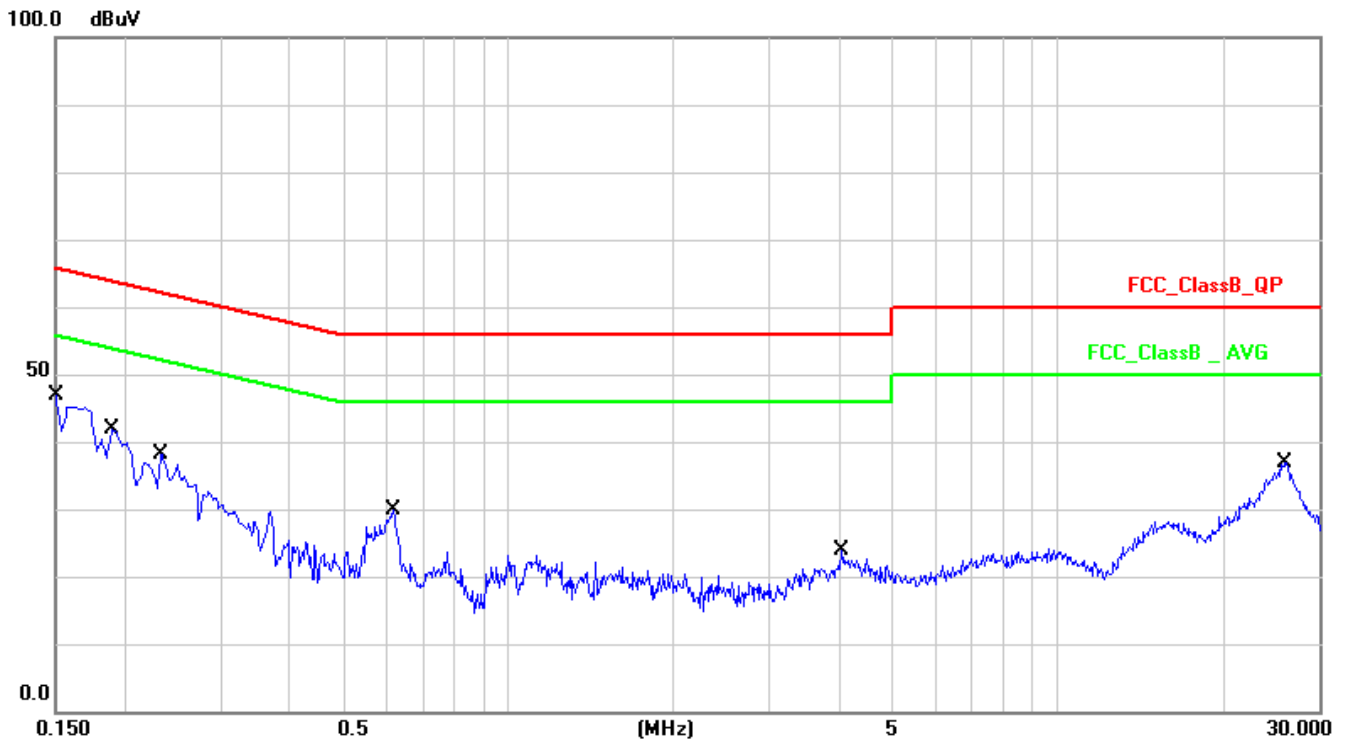

No.	Frequency (MHz)	Factor (dB)	Reading (dBuV)	Level (dBuV)	Limit (dBuV)	Margin (dB)	Detector
1	0.1499	10.15	-5.75	4.40	66.00	-61.60	QP
2	0.1499	10.15	-13.05	-2.90	56.00	-58.90	AVG
3	0.1900	10.13	28.38	38.51	64.03	-25.52	QP
4	0.1900	10.13	9.92	20.05	54.03	-33.98	AVG
5	0.2340	10.13	23.52	33.65	62.30	-28.65	QP
6	0.2340	10.13	7.26	17.39	52.30	-34.91	AVG
7	0.6180	10.15	16.90	27.05	56.00	-28.95	QP
8	0.6180	10.15	8.30	18.45	46.00	-27.55	AVG
9	4.0579	10.23	6.82	17.05	56.00	-38.95	QP
10	4.0579	10.23	1.15	11.38	46.00	-34.62	AVG
11	26.0860	10.45	20.49	30.94	60.00	-29.06	QP



12	26.0860	10.45	10.29	20.74	50.00	-29.26	AVG
----	---------	-------	-------	-------	-------	--------	-----

Note: Level = Reading + Factor

Margin = Level – Limit

Factor = (LISN or ISN or PLC or current probe) Factor + Cable Loss + Attenuator



Test Standard:	FCC_ClassB_QP	Probe:	N
Test item:	Conduction Emission	Test Time:	2019/8/139:48:41
Applicant:	Mitac Digital Technology Company	Power Rating:	AC 120V/60Hz
Product:	Tablet	Temp.(C)/Hum.(%)/Air p.(hpa):	26(°C)/60%/1000hpa
Model No.:	N642	Test Engineer:	Chris
Test Mode:	BLE		
Remark:	Adapter Power		

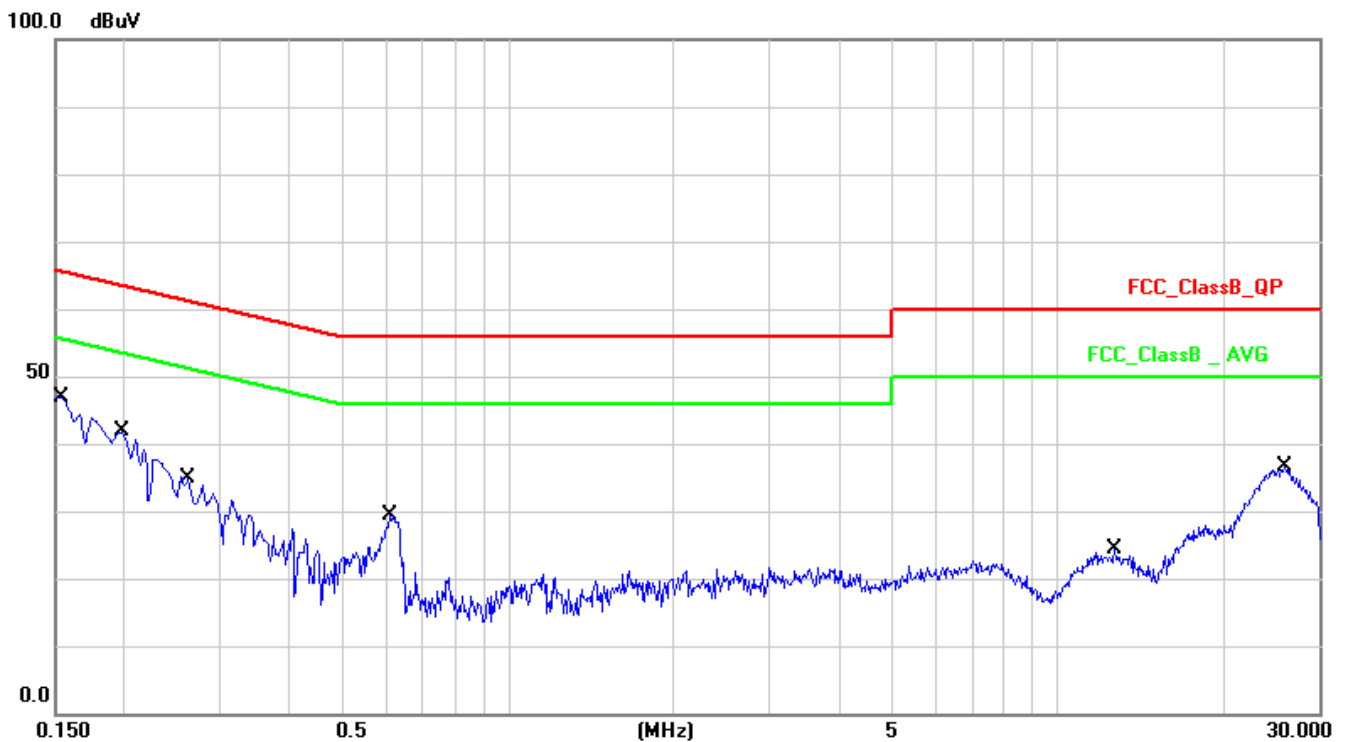

No.	Frequency (MHz)	Factor (dB)	Reading (dBuV)	Level (dBuV)	Limit (dBuV)	Margin (dB)	Detector
1	0.1539	10.15	33.22	43.37	65.78	-22.41	QP
2	0.1539	10.15	13.60	23.75	55.78	-32.03	AVG
3	0.1980	10.14	27.61	37.75	63.69	-25.94	QP
4	0.1980	10.14	9.78	19.92	53.69	-33.77	AVG
5	0.2620	10.14	21.74	31.88	61.36	-29.48	QP
6	0.2620	10.14	5.81	15.95	51.36	-35.41	AVG
7	0.6100	10.16	16.14	26.30	56.00	-29.70	QP
8	0.6100	10.16	8.42	18.58	46.00	-27.42	AVG
9	12.7580	10.44	7.97	18.41	60.00	-41.59	QP
10	12.7580	10.44	2.57	13.01	50.00	-36.99	AVG



11	25.9860	10.35	20.50	30.85	60.00	-29.15	QP
12	25.9860	10.35	11.24	21.59	50.00	-28.41	AVG

Note: Level = Reading + Factor

Margin = Level – Limit

Factor = (LISN or ISN or PLC or current probe) Factor + Cable Loss + Attenuator



Test Standard:	FCC_ClassB_QP	Probe:	L1
Test item:	Conduction Emission	Test Time:	2019/8/1311:09:34
Applicant:	Mitac Digital Technology Company	Power Rating:	AC 120V/60Hz
Product:	Tablet	Temp.(C)/Hum.(/Air p.(hpa):	26(°C)/60%/1000hpa
Model No.:	N642	Test Engineer:	Chris
Test Mode:	BLE		
Remark:	POE Power		

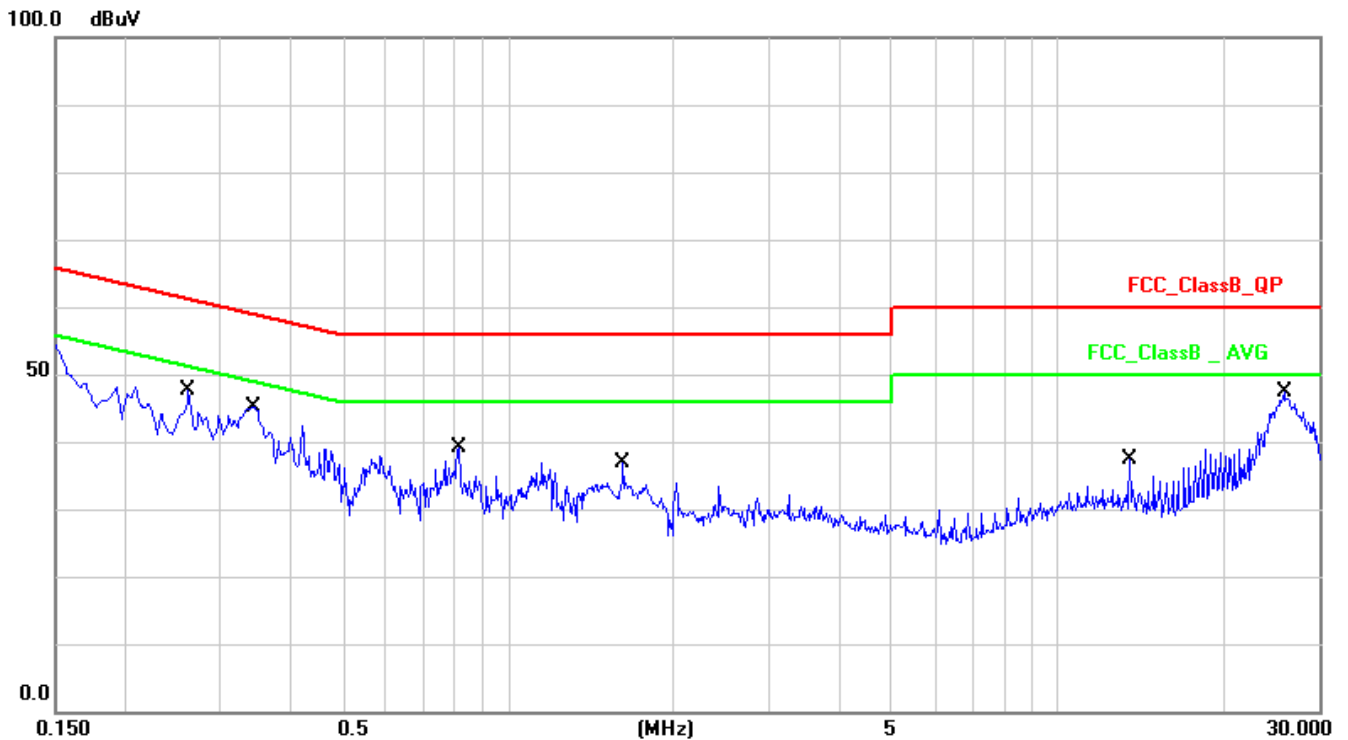

No.	Frequency (MHz)	Factor (dB)	Reading (dBuV)	Level (dBuV)	Limit (dBuV)	Margin (dB)	Detector
1	0.2620	10.14	28.77	38.91	61.36	-22.45	QP
2	0.2620	10.14	19.94	30.08	51.36	-21.28	AVG
3	0.3460	10.14	33.57	43.71	59.06	-15.35	QP
4	0.3460	10.14	26.24	36.38	49.06	-12.68	AVG
5	0.8139	10.16	26.53	36.69	56.00	-19.31	QP
6	0.8139	10.16	20.53	30.69	46.00	-15.31	AVG
7	1.6220	10.18	22.64	32.82	56.00	-23.18	QP
8	1.6220	10.18	18.29	28.47	46.00	-17.53	AVG
9	13.6220	10.49	18.25	28.74	60.00	-31.26	QP
10	13.6220	10.49	9.38	19.87	50.00	-30.13	AVG
11	25.9100	10.45	31.39	41.84	60.00	-18.16	QP



12	25.9100	10.45	25.47	35.92	50.00	-14.08	AVG
----	---------	-------	-------	-------	-------	--------	-----

Note: Level = Reading + Factor

Margin = Level – Limit

Factor = (LISN or ISN or PLC or current probe) Factor + Cable Loss + Attenuator



Test Standard:	FCC_ClassB_QP	Probe:	N
Test item:	Conduction Emission	Test Time:	2019/8/1311:06:51
Applicant:	Mitac Digital Technology Company	Power Rating:	AC 120V/60Hz
Product:	Tablet	Temp.(C)/Hum.(/Air p.(hpa):	26(°C)/60%/1000hpa
Model No.:	N642	Test Engineer:	Chris
Test Mode:	BLE		
Remark:	POE Power		

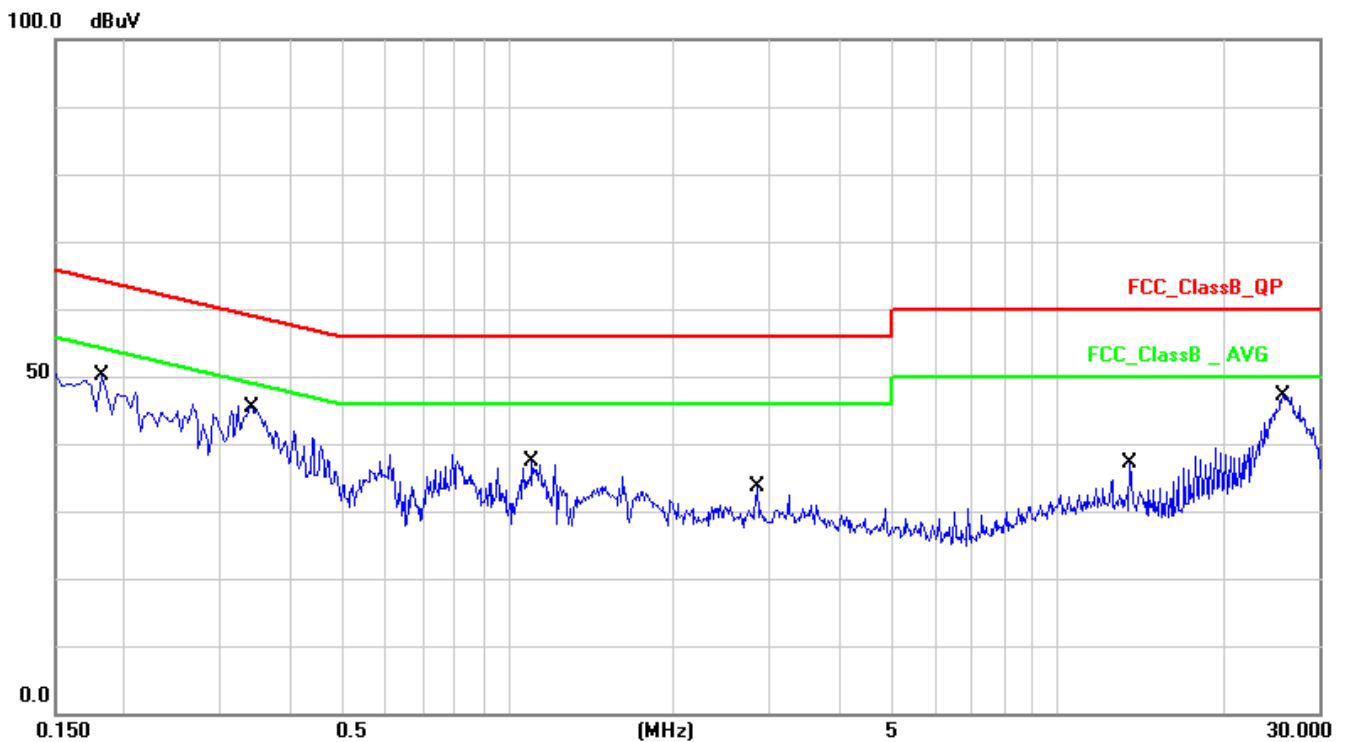

No.	Frequency (MHz)	Factor (dB)	Reading (dBuV)	Level (dBuV)	Limit (dBuV)	Margin (dB)	Detector
1	0.1819	10.14	33.32	43.46	64.39	-20.93	QP
2	0.1819	10.14	15.61	25.75	54.39	-28.64	AVG
3	0.3420	10.14	33.48	43.62	59.15	-15.53	QP
4	0.3420	10.14	26.14	36.28	49.15	-12.87	AVG
5	1.1100	10.19	22.52	32.71	56.00	-23.29	QP
6	1.1100	10.19	14.43	24.62	46.00	-21.38	AVG
7	2.8420	10.22	20.99	31.21	56.00	-24.79	QP
8	2.8420	10.22	16.70	26.92	46.00	-19.08	AVG
9	13.6140	10.49	20.79	31.28	60.00	-28.72	QP
10	13.6140	10.49	9.88	20.37	50.00	-29.63	AVG



11	25.8460	10.36	31.30	41.66	60.00	-18.34	QP
12	25.8460	10.36	25.31	35.67	50.00	-14.33	AVG

Note: Level = Reading + Factor

Margin = Level – Limit

Factor = (LISN or ISN or PLC or current probe) Factor + Cable Loss + Attenuator



4. Radiated Emission Measurement

4.1 Test Limit

In any 100kHz bandwidth outside the frequency band in which the spread spectrum or digitally modulated intentional radiator is operating, the radio frequency power that is produced by the intentional radiator shall be at least 20dB below that in the 100kHz bandwidth within the band that contains the highest level of the desired power, based on either an RF conducted or a radiated measurement. If the transmitter measurement is based on the maximum conducted output power, the attenuation required under this paragraph shall be 30dB instead of 20dB. In addition, radiated emissions which fall in section 15.205(a) the restricted bands must also comply with the radiated emission limit specified in section 15.209(a).

FCC Part 15 Subpart C Paragraph 15.209		
FREQUENCIES (MHz)	FIELD STRENGTH (micro volts/meter)	MEASUREMENT DISTANCE (meters)
0.009~0.490	2400/F(kHz)	300
0.490~1.705	24000/F(kHz)	30
1.705~30.0	30	30
30~88	100	3
88~216	150	3
216~960	200	3
Above 960	500	3

Note 1: The lower limit shall apply at the transition frequency.

Note 2: Distance refers to the distance in meters between the measuring instrument Antenna and the closed point of any part of the device or system.

Note 3: E field strength (dBuV/m) = 20 log E field strength (uV/m)

Note 4: **Except as provided in paragraph (g), fundamental emissions from intentional radiators operating under this section shall not be located in the frequency bands 54-72 MHz, 76-88 MHz, 174-216 MHz or 470-806 MHz. However, operation within these frequency bands is permitted under other sections of this part, e.g., §§15.231 and 15.241.

4.2 Test Standard

KDB 558074 D01v05r02 - Section 8.5 & Section 8.6



4.3 Test Procedures

Quasi-Peak Field Strength Measurements:

The specifications for measurements using the CISPR quasi-peak detector can be found in Publication 16 of the International Special Committee on Radio Frequency Interference (CISPR) of the International Electrotechnical Commission.

As an alternative to CISPR quasi-peak measurement, compliance can be demonstrated to the applicable emission limits using a peak detector.

Peak Field Strength Measurements:

Analyzer center frequency was set to the frequency of the radiated spurious emission of interest

1. RBW=As specified in Table 1
2. VBW=3×RBW
3. Detector=Peak
4. Trace mode=Max hold
5. Sweep time=Auto couple
6. Allow the trace to stabilize

Table 1-RBW as a function of frequency

Frequency	RBW
9 ~ 150kHz	200 ~ 300Hz
0.15 ~ 30MHz	9 ~ 10kHz
30 ~ 1000MHz	100 ~ 120kHz
> 1000MHz	1MHz

AVE Field Strength Measurements:

Analyzer center frequency was set to the frequency of the radiated spurious emission of interest

1. RBW= 1MHz
2. VBW≥1/T
3. Detector=Peak
4. Trace mode=Max hold
5. Sweep time=Auto couple
6. Allow max hold to run for at least 50 times(1/duty cycle) trace

Do as an alternative, the instrument may be set to linear detector mode. Ensure that video filtering is applied in linear voltage domain (rather than in a log or dB domain). Some instruments require linear display mode in order to accomplish this. Others have a setting for Average-VBW Type, which can be set to "Voltage" regardless of the display mode



4.4 Test Setup Layout

9kHz~30MHz Test Setup

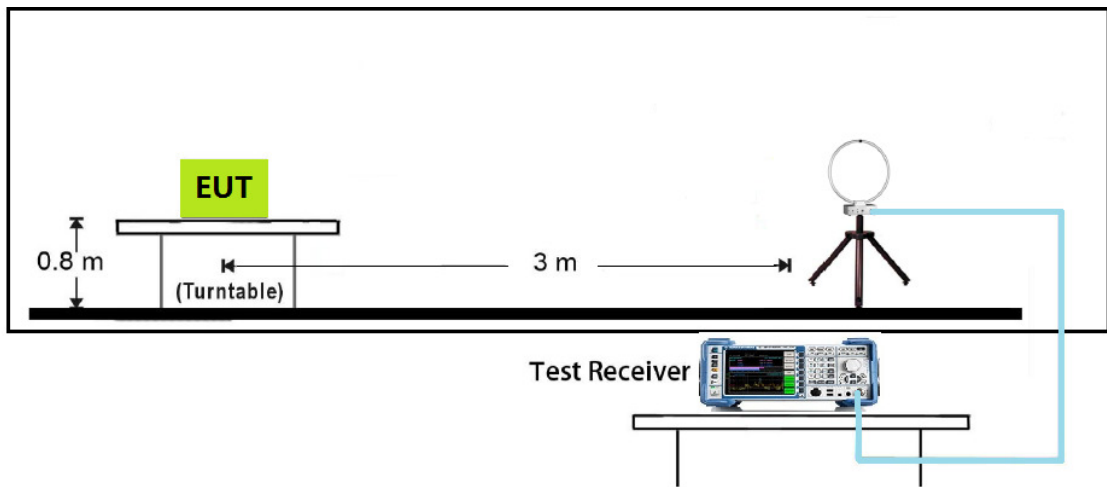

30MHz~1GHz Test Setup

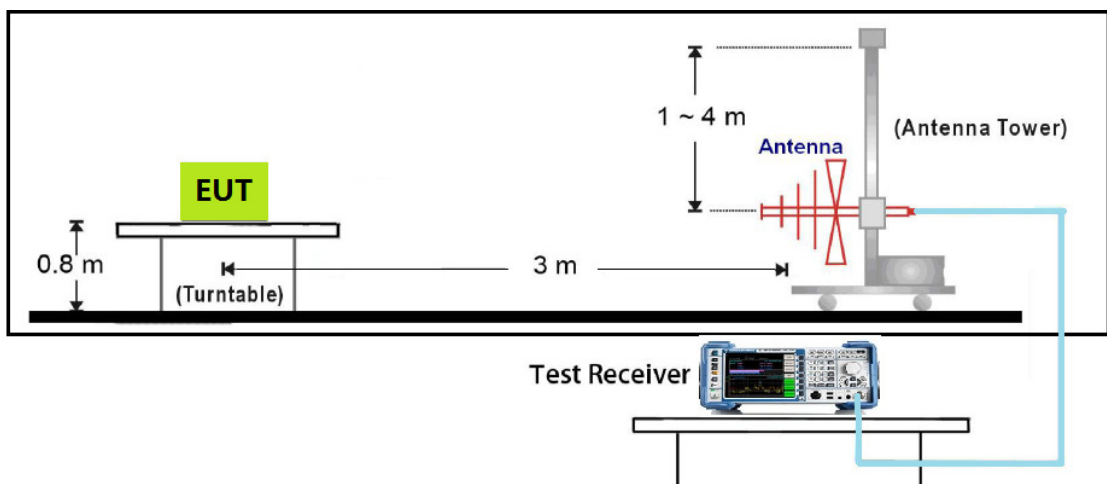



1GHz~18GHz Test Setup

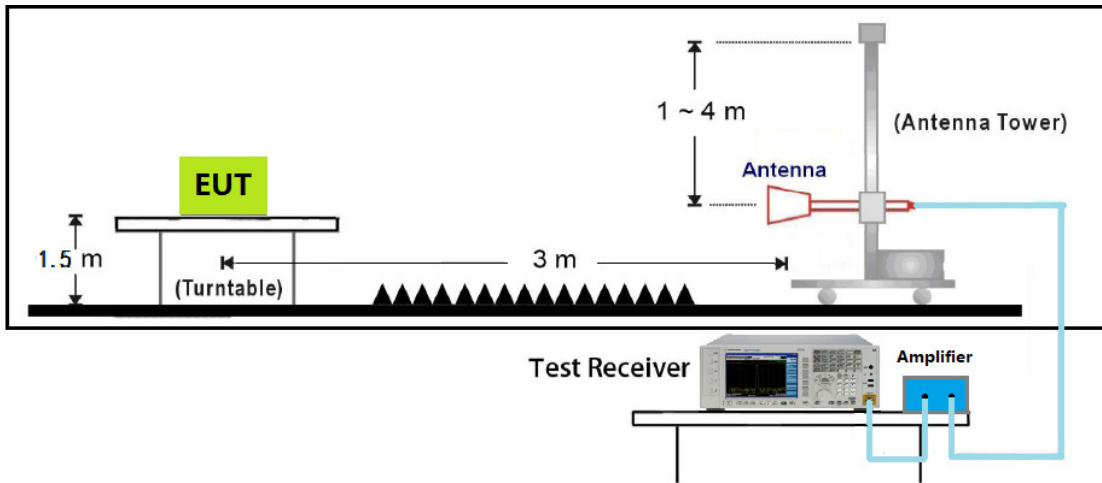

18GHz~40GHz Test Setup

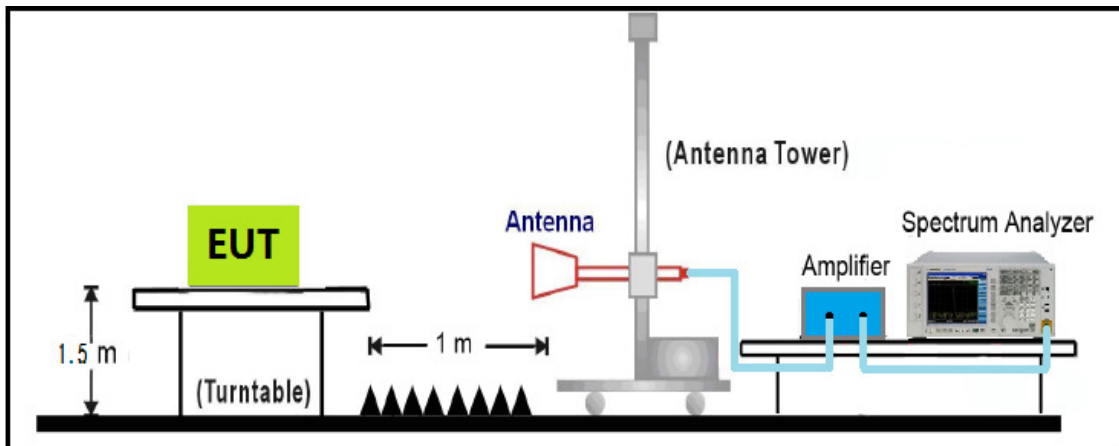



4.5 Test Result

The worst case of Radiated Emission below 1GHz:

Test Distance:	3M		
Test Standard:	FCC Class B 3M Radiation	Ant. Polarization:	Horizontal
Test item:	Radiation Emission	Test Time:	2019-8-1516:24:24
Applicant:	Mitac Digital Technology Company	Power Rating:	AC 120V/60Hz
Product:	Tablet	Temp.(C)/Hum.(%)/Air p.(hpa):	26(°C)/60%/983hpa
Model No.:	N642	Test Engineer:	Chris
Test Mode:	BLE		
Remark:	Adapter Power		

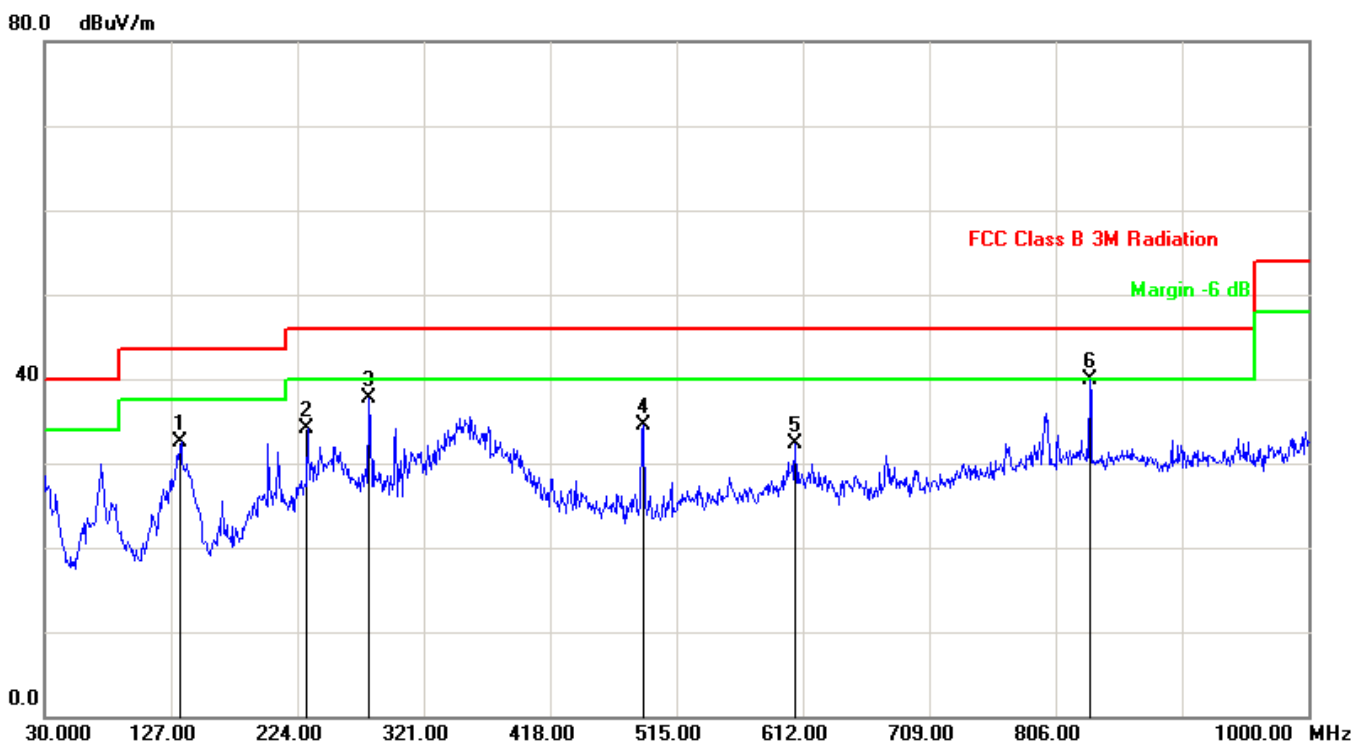

No.	Frequency (MHz)	Factor (dB/m)	Reading (dBuV)	Level (dBuV/m)	Limit (dBuV/m)	Margin (dB)	Det.
1	134.7598	-12.05	44.56	32.51	43.50	-10.99	peak
2	231.7598	-10.96	44.98	34.02	46.00	-11.98	peak
3	279.2900	-8.29	46.03	37.74	46.00	-8.26	peak
4	489.7798	-5.49	39.93	34.44	46.00	-11.56	peak
5	606.1798	-3.67	35.99	32.32	46.00	-13.68	peak
6	832.1900	2.21	37.68	39.89	46.00	-6.11	peak

Note: Measure Level (dB μ V/m) = Reading Level (dB μ V) + Factor (dB)

Factor (dB) = Cable Loss (dB) + Antenna Factor (dB/m) - Pre_Amplifier Gain (dB)



Test Distance:	3M		
Test Standard:	FCC Class B 3M Radiation	Ant. Polarization:	Vertical
Test item:	Radiation Emission	Test Time:	2019-8-1516:19:42
Applicant:	Mitac Digital Technology Company	Power Rating:	AC 120V/60Hz
Product:	Tablet	Temp.(C)/Hum.(/Air p.(hpa):	26(°C)/60%/983hpa
Model No.:	N642	Test Engineer:	Chris
Test Mode:	BLE		
Remark:	Adapter Power		

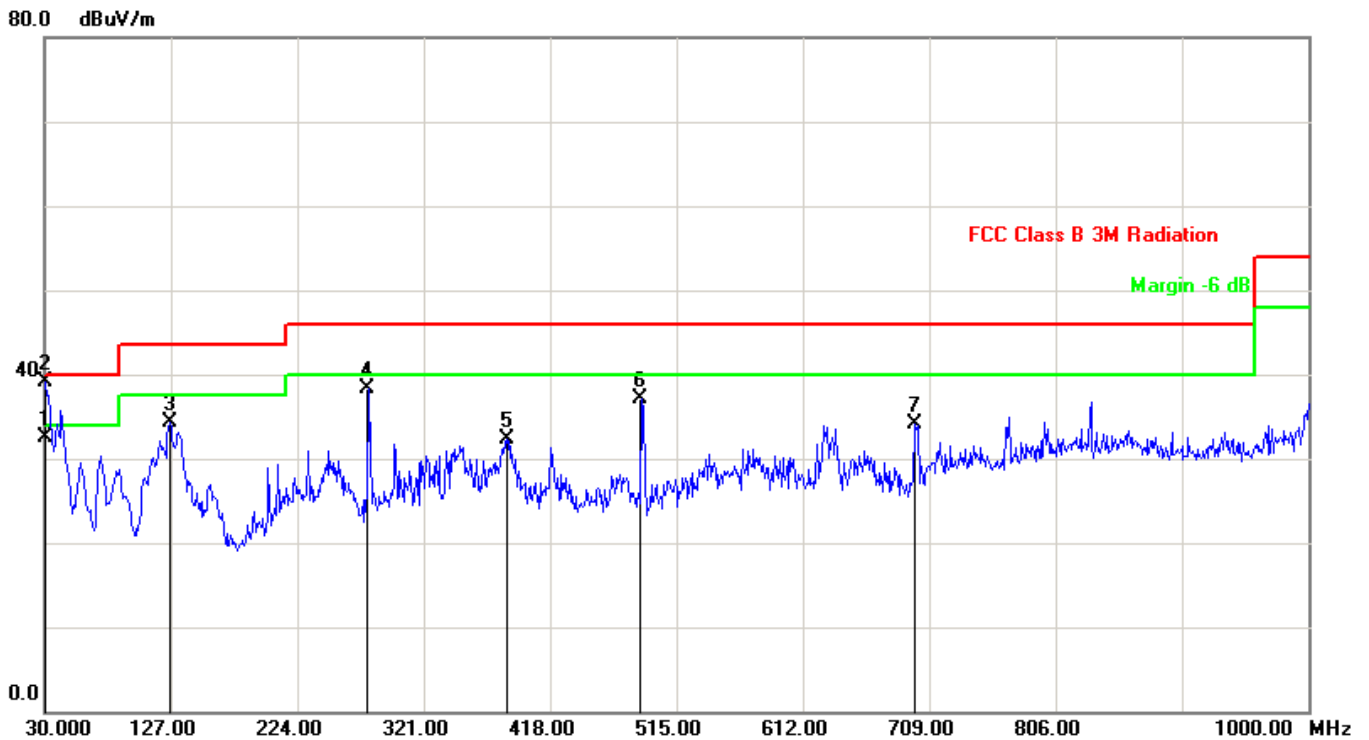

No.	Frequency (MHz)	Factor (dB/m)	Reading (dBuV)	Level (dBuV/m)	Limit (dBuV/m)	Margin (dB)	Det.
1	30.1400	-4.31	36.89	32.58	40.00	-7.42	QP
2	30.9698	-4.67	43.73	39.06	40.00	-0.94	peak
3	126.0300	-12.13	46.39	34.26	43.50	-9.24	peak
4	278.3199	-8.38	46.75	38.37	46.00	-7.63	peak
5	385.0199	-7.32	39.65	32.33	46.00	-13.67	peak
6	487.8399	-5.49	42.64	37.15	46.00	-8.85	peak
7	697.3600	-2.09	36.10	34.01	46.00	-11.99	peak

Note: Measure Level (dBuV/m) = Reading Level (dBuV) + Factor (dB)

Factor (dB) = Cable Loss (dB) + Antenna Factor (dB/m) - Pre_Amplifier Gain (dB)



Test Distance:	3M		
Test Standard:	FCC Class B 3M Radiation	Ant. Polarization:	Horizontal
Test item:	Radiation Emission	Test Time:	2019-8-1520:21:06
Applicant:	Mitac Digital Technology Company	Power Rating:	AC 120V/60Hz
Product:	Tablet	Temp.(C)/Hum.(%)/Air p.(hpa):	26(°C)/60%/983hpa
Model No.:	N642	Test Engineer:	Chris
Test Mode:	BLE		
Remark:	POE Power		

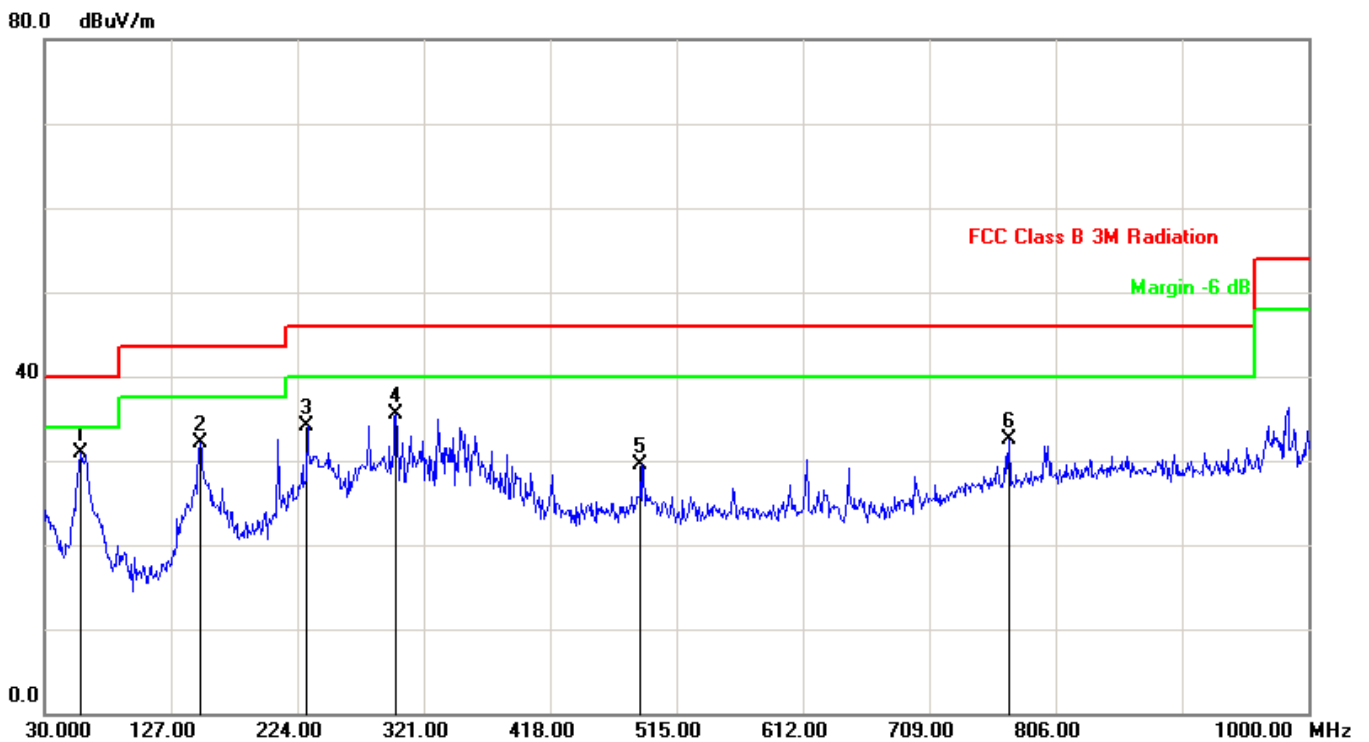

No.	Frequency (MHz)	Factor (dB/m)	Reading (dBuV)	Level (dBuV/m)	Limit (dBuV/m)	Margin (dB)	Det.
1	58.1300	-14.55	45.53	30.98	40.00	-9.02	peak
2	149.3100	-12.52	44.67	32.15	43.50	-11.35	peak
3	231.7598	-10.96	45.10	34.14	46.00	-11.86	peak
4	299.6600	-7.85	43.35	35.50	46.00	-10.50	peak
5	487.8399	-5.49	35.01	29.52	46.00	-16.48	peak
6	770.1100	1.42	31.01	32.43	46.00	-13.57	peak

Note: Measure Level (dBμV/m) = Reading Level (dBμV) + Factor (dB)

Factor (dB) = Cable Loss (dB) + Antenna Factor (dB/m) - Pre_Amplifier Gain (dB)



Test Distance:	3M		
Test Standard:	FCC Class B 3M Radiation	Ant. Polarization:	Vertical
Test item:	Radiation Emission	Test Time:	2019-8-1520:23:19
Applicant:	Mitac Digital Technology Company	Power Rating:	AC 120V/60Hz
Product:	Tablet	Temp.(C)/Hum.(/Air p.(hpa):	26(°C)/60%/983hpa
Model No.:	N642	Test Engineer:	Chris
Test Mode:	BLE		
Remark:	POE Power		

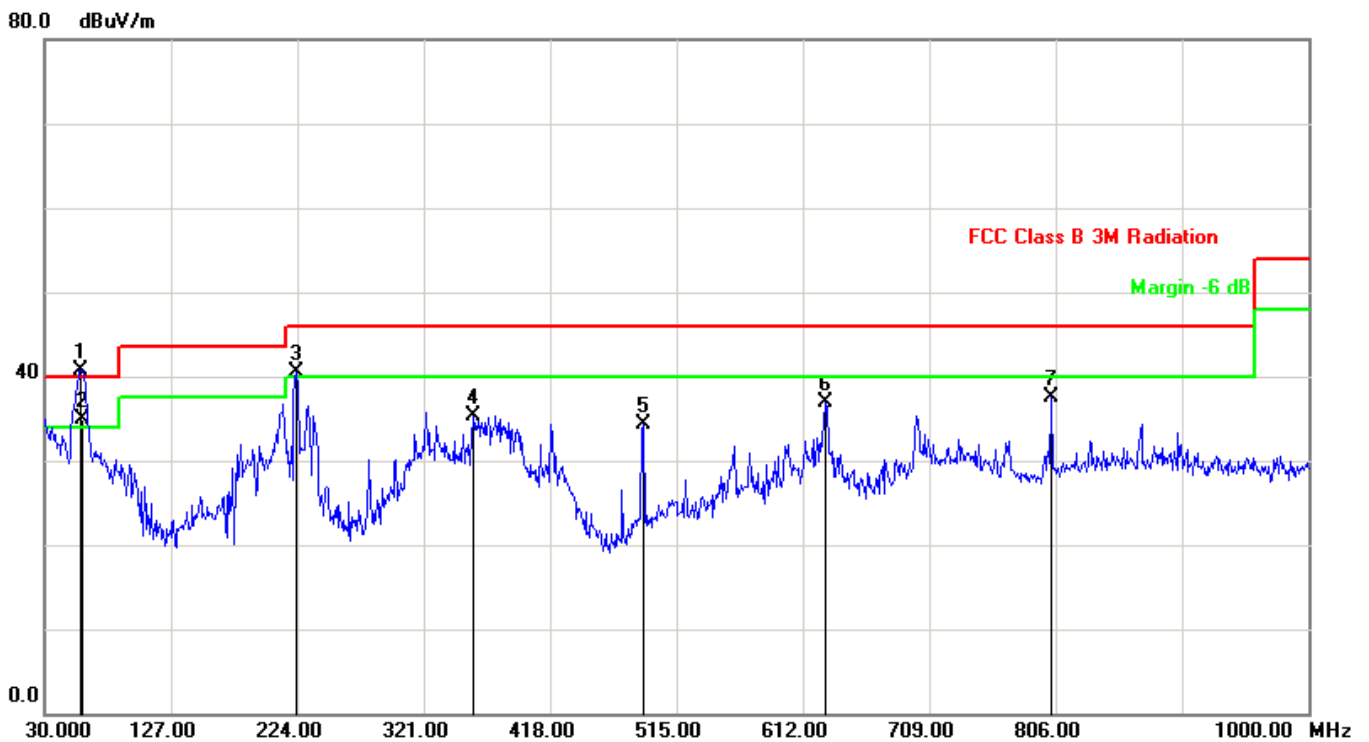

No.	Frequency (MHz)	Factor (dB/m)	Reading (dBuV)	Level (dBuV/m)	Limit (dBuV/m)	Margin (dB)	Det.
1	57.5599	-12.25	53.00	40.75	40.00	0.75	peak
2	58.6600	-12.43	47.24	34.81	40.00	-5.19	QP
3	223.0300	-12.15	52.70	40.55	46.00	-5.45	peak
4	358.8299	-6.83	42.08	35.25	46.00	-10.75	peak
5	489.7798	-5.54	39.92	34.38	46.00	-11.62	peak
6	629.4600	-1.63	38.58	36.95	46.00	-9.05	peak
7	803.0900	0.83	36.63	37.46	46.00	-8.54	peak

Note: Measure Level (dBuV/m) = Reading Level (dBuV) + Factor (dB)

Factor (dB) = Cable Loss (dB) + Antenna Factor (dB/m) - Pre_Amplifier Gain (dB)

**Radiated Emission above 1GHz:**

Test Distance:	3M		
Test Standard:	FCC Class B Above 1G 3M Radiation PK	Ant. Polarization:	Horizontal
Test item:	Radiation Emission	Test Time:	2019-8-619:47:06
Applicant:	Mitac Digital Technology Company	Power Rating:	AC 120V/60Hz
Product:	Tablet	Temp.(C)/Hum.(%)/Air p.(hpa):	26(°C)/60%/983hpa
Model No.:	N642	Test Engineer:	Chris
Test Mode:	BT4.0-LE 2402MHz		
Remark:	POE Power		

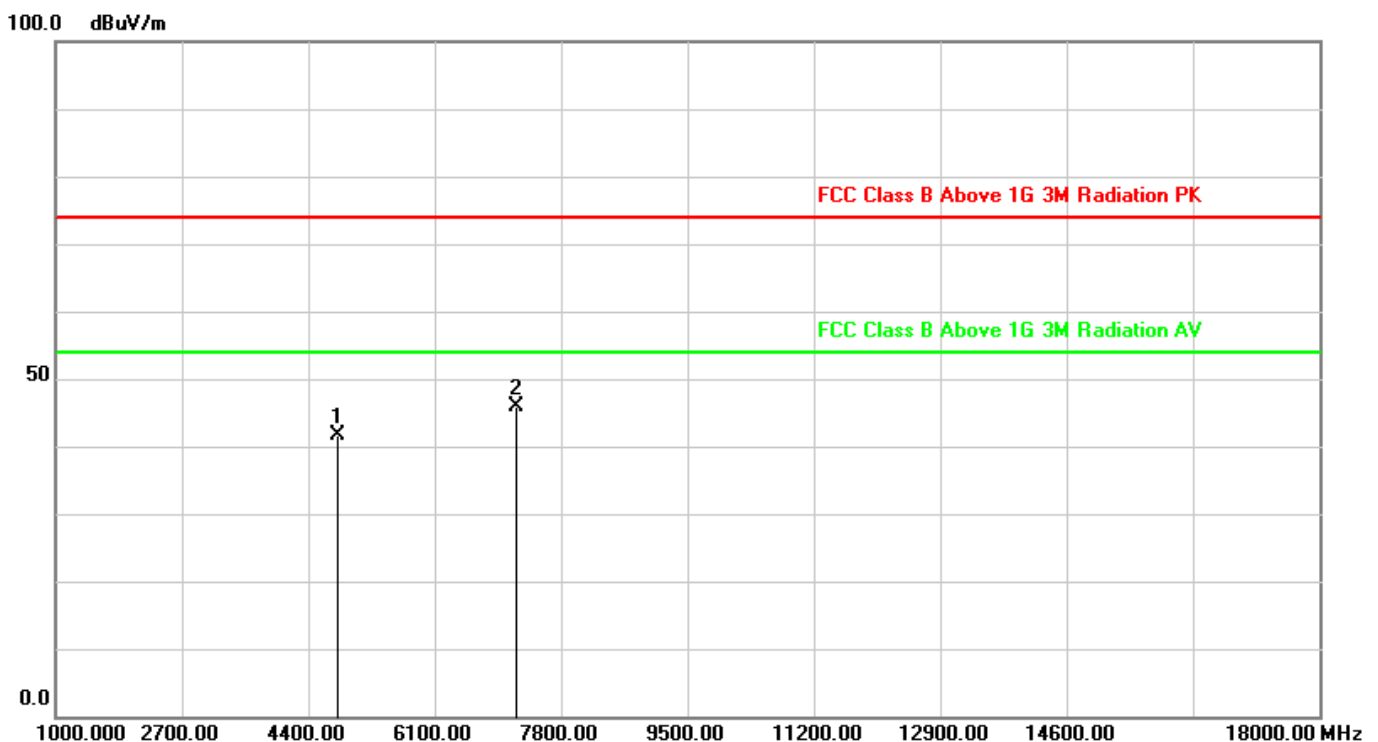

No.	Frequency (MHz)	Factor (dB/m)	Reading (dBuV)	Level (dBuV/m)	Limit (dBuV/m)	Margin (dB)	Det.
1	4804.000	3.28	38.38	41.66	74.00	-32.34	peak
2	7206.000	8.19	37.58	45.77	74.00	-28.23	peak

Note: 1. All Readings below 1GHz are Quasi-Peak, above are performed with peak and/or AVG measurements as necessary.

2. Measurement Level = Reading Level + Correct Factor.

3. The test trace is same as the ambient noise (the test frequency range: 9kHz~30MHz, 18GHz~40GHz), therefore no data appear in the report.

4. This limit applies for using average detector, if the test result on peak is lower than average limit, then average measurement needn't be performed.



Test Distance:	3M		
Test Standard:	FCC Class B Above 1G 3M	Ant. Polarization:	Vertical
	Radiation PK		
Test item:	Radiation Emission	Test Time:	2019-8-619:50:12
Applicant:	Mitac Digital Technology Company	Power Rating:	AC 120V/60Hz
Product:	Tablet	Temp.(C)/Hum.(%)/Air p.(hpa):	26(°C)/60%/983hpa
Model No.:	N642	Test Engineer:	Chris
Test Mode:	BT4.0-LE 2402MHz		
Remark:	POE Power		

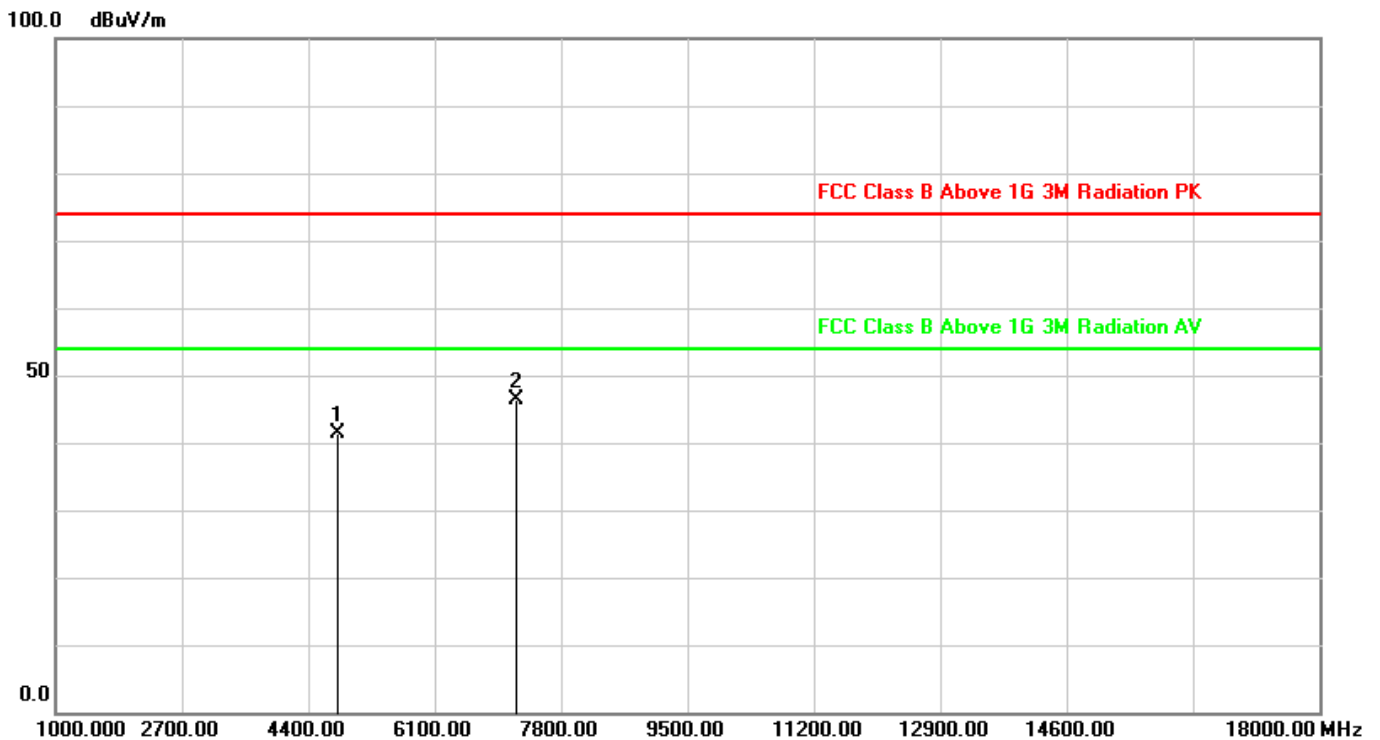

No.	Frequency (MHz)	Factor (dB/m)	Reading (dBuV)	Level (dBuV/m)	Limit (dBuV/m)	Margin (dB)	Det.
1	4804.000	3.28	38.11	41.39	74.00	-32.61	peak
2	7206.000	8.19	38.26	46.45	74.00	-27.55	peak

Note: 1. All Readings below 1GHz are Quasi-Peak, above are performed with peak and/or AVG measurements as necessary.

2. Measurement Level = Reading Level + Correct Factor.

3. The test trace is same as the ambient noise (the test frequency range: 9kHz~30MHz, 18GHz~40GHz), therefore no data appear in the report.

4. This limit applies for using average detector, if the test result on peak is lower than average limit, then average measurement needn't be performed.



Test Distance:	3M		
Test Standard:	FCC Class B Above 1G 3M	Ant. Polarization:	Horizontal
	Radiation PK		
Test item:	Radiation Emission	Test Time:	2019-8-619:53:03
Applicant:	Mitac Digital Technology Company	Power Rating:	AC 120V/60Hz
Product:	Tablet	Temp.(C)/Hum.(%)/Air p.(hpa):	26(°C)/60%/983hpa
Model No.:	N642	Test Engineer:	Chris
Test Mode:	BT4.0-LE 2440MHz		
Remark:	POE Power		

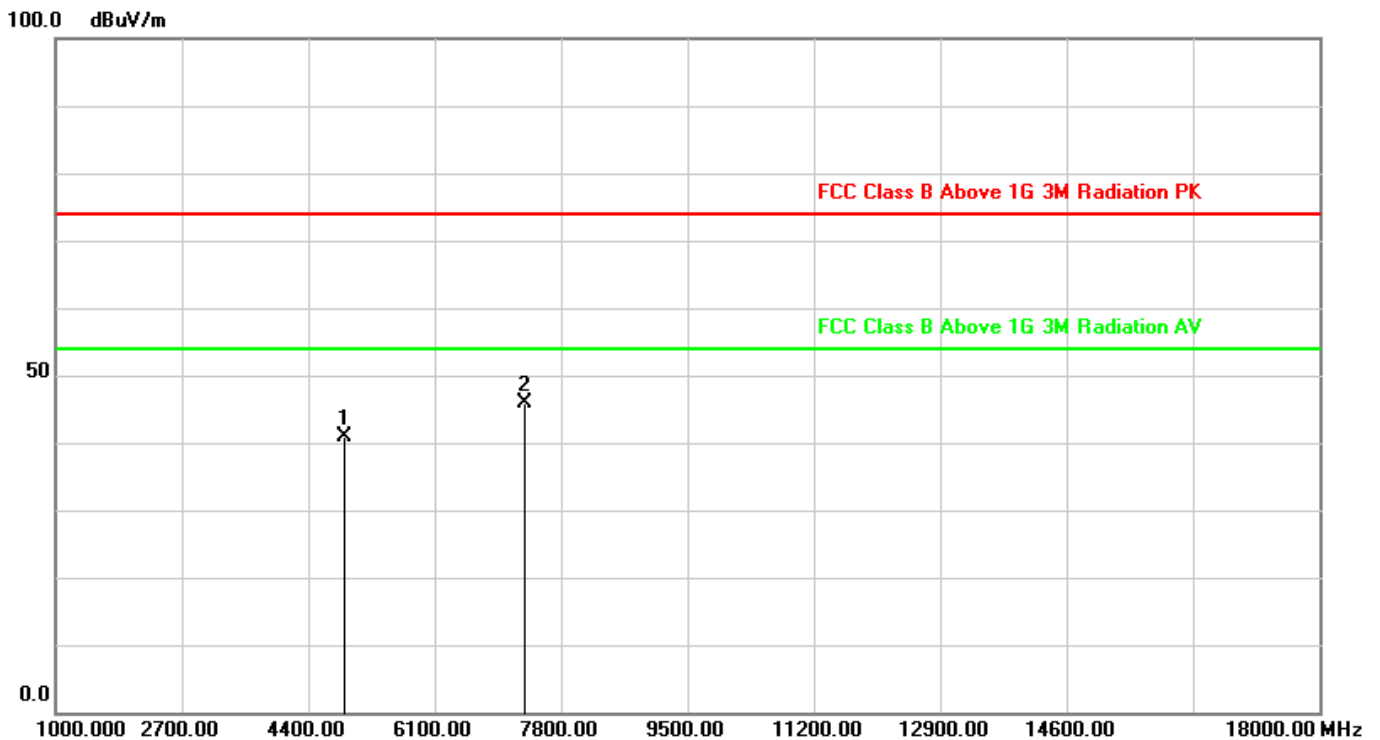

No.	Frequency (MHz)	Factor (dB/m)	Reading (dBuV)	Level (dBuV/m)	Limit (dBuV/m)	Margin (dB)	Det.
1	4880.000	3.43	37.34	40.77	74.00	-33.23	peak
2	7320.000	8.27	37.62	45.89	74.00	-28.11	peak

Note: 1. All Readings below 1GHz are Quasi-Peak, above are performed with peak and/or AVG measurements as necessary.

2. Measurement Level = Reading Level + Correct Factor.

3. The test trace is same as the ambient noise (the test frequency range: 9kHz~30MHz, 18GHz~40GHz), therefore no data appear in the report.

4. This limit applies for using average detector, if the test result on peak is lower than average limit, then average measurement needn't be performed.



Test Distance:	3M		
Test Standard:	FCC Class B Above 1G 3M	Ant. Polarization:	Vertical
	Radiation PK		
Test item:	Radiation Emission	Test Time:	2019-8-619:54:27
Applicant:	Mitac Digital Technology Company	Power Rating:	AC 120V/60Hz
Product:	Tablet	Temp.(C)/Hum.(%)/Air p.(hpa):	26(°C)/60%/983hpa
Model No.:	N642	Test Engineer:	Chris
Test Mode:	BT4.0-LE 2440MHz		
Remark:	POE Power		

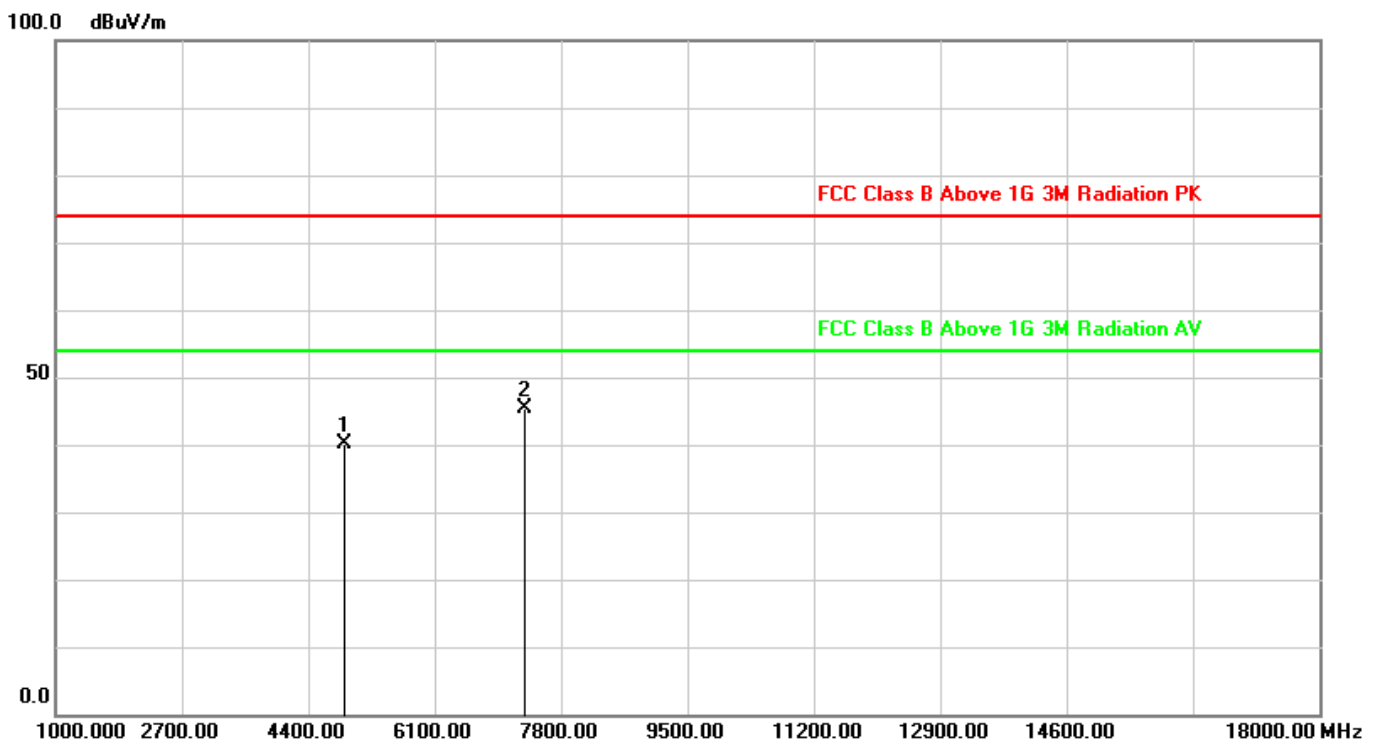

No.	Frequency (MHz)	Factor (dB/m)	Reading (dBuV)	Level (dBuV/m)	Limit (dBuV/m)	Margin (dB)	Det.
1	4880.000	3.43	36.77	40.20	74.00	-33.80	peak
2	7320.000	8.27	37.19	45.46	74.00	-28.54	peak

Note: 1. All Readings below 1GHz are Quasi-Peak, above are performed with peak and/or AVG measurements as necessary.

2. Measurement Level = Reading Level + Correct Factor.

3. The test trace is same as the ambient noise (the test frequency range: 9kHz~30MHz, 18GHz~40GHz), therefore no data appear in the report.

4. This limit applies for using average detector, if the test result on peak is lower than average limit, then average measurement needn't be performed.



Test Distance:	3M		
Test Standard:	FCC Class B Above 1G 3M	Ant. Polarization:	Horizontal
	Radiation PK		
Test item:	Radiation Emission	Test Time:	2019-8-619:58:20
Applicant:	Mitac Digital Technology Company	Power Rating:	AC 120V/60Hz
Product:	Tablet	Temp.(C)/Hum.(%)/Air p.(hpa):	26(°C)/60%/983hpa
Model No.:	N642	Test Engineer:	Chris
Test Mode:	BT4.0-LE 2480MHz		
Remark:	POE Power		

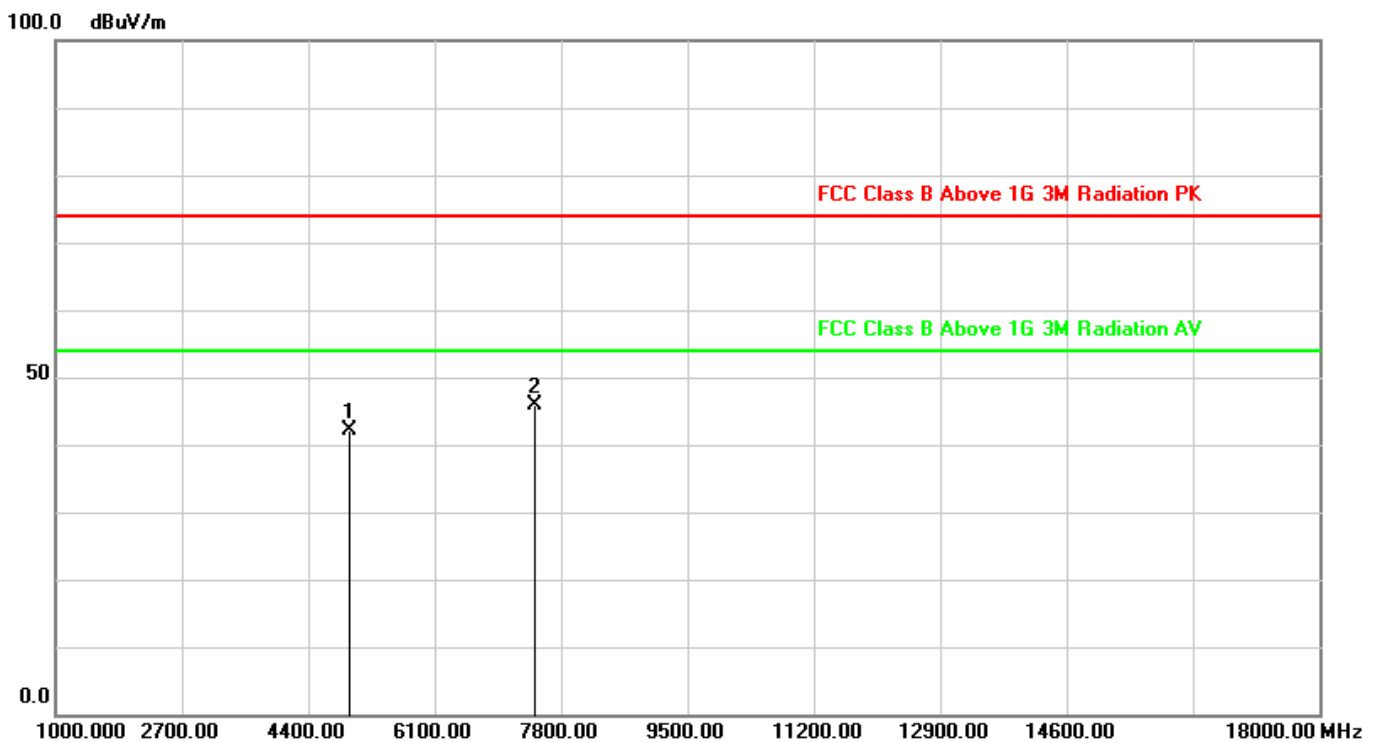

No.	Frequency (MHz)	Factor (dB/m)	Reading (dBuV)	Level (dBuV/m)	Limit (dBuV/m)	Margin (dB)	Det.
1	4960.000	3.59	38.58	42.17	74.00	-31.83	peak
2	7440.000	8.36	37.48	45.84	74.00	-28.16	peak

Note: 1. All Readings below 1GHz are Quasi-Peak, above are performed with peak and/or AVG measurements as necessary.

2. Measurement Level = Reading Level + Correct Factor.

3. The test trace is same as the ambient noise (the test frequency range: 9kHz~30MHz, 18GHz~40GHz), therefore no data appear in the report.

4. This limit applies for using average detector, if the test result on peak is lower than average limit, then average measurement needn't be performed.



Test Distance:	3M		
Test Standard:	FCC Class B Above 1G 3M	Ant. Polarization:	Vertical
	Radiation PK		
Test item:	Radiation Emission	Test Time:	2019-8-619:59:44
Applicant:	Mitac Digital Technology Company	Power Rating:	AC 120V/60Hz
Product:	Tablet	Temp.(C)/Hum.(%)/Air p.(hpa):	26(°C)/60%/983hpa
Model No.:	N642	Test Engineer:	Chris
Test Mode:	BT4.0-LE 2480MHz		
Remark:	POE Power		

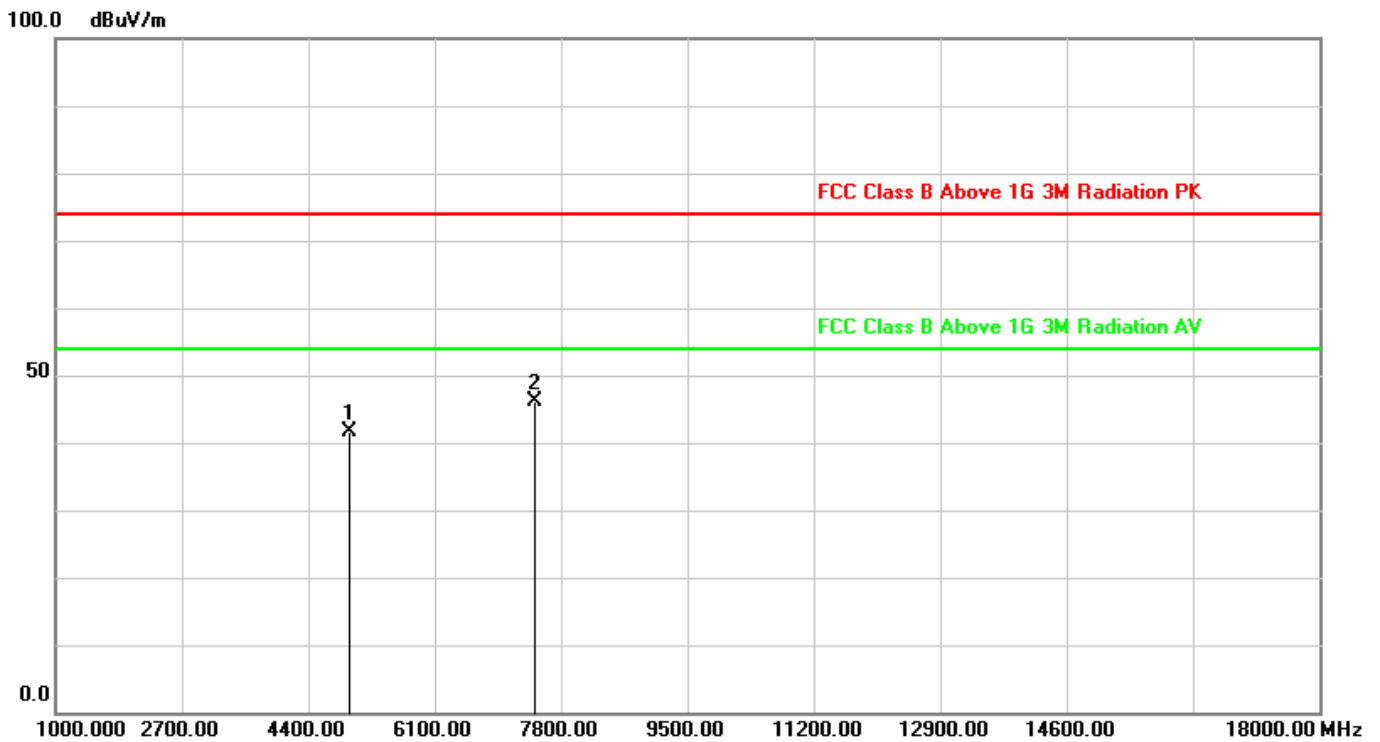

No.	Frequency (MHz)	Factor (dB/m)	Reading (dBuV)	Level (dBuV/m)	Limit (dBuV/m)	Margin (dB)	Det.
1	4960.000	3.59	37.94	41.53	74.00	-32.47	peak
2	7440.000	8.36	37.78	46.14	74.00	-27.86	peak

Note: 1. All Readings below 1GHz are Quasi-Peak, above are performed with peak and/or AVG measurements as necessary.

2. Measurement Level = Reading Level + Correct Factor.

3. The test trace is same as the ambient noise (the test frequency range: 9kHz~30MHz, 18GHz~40GHz), therefore no data appear in the report.

4. This limit applies for using average detector, if the test result on peak is lower than average limit, then average measurement needn't be performed.



5. 6dB Bandwidth Measurement

5.1 Test Limit

According to FCC part15.247 - Section (a)(2), the minimum 6dB bandwidth shall be at least 500 kHz.

5.2 Test Standard

KDB 558074 D01v05r02– Section 8.2

5.3 Test Procedures

1. Set RBW=100KHz
2. VBW \geq 3 \times RBW
3. Detector=Peak
4. Trace mode=Max hold
5. Sweep time=Auto couple
6. Allow the trace to stabilize
7. The Spectrum's automatic bandwidth measurement capability was used to perform the 6dB bandwidth measurement. The "X" dB bandwidth parameter was set to X = 6. The bandwidth measurement was not influenced by any intermediate power nulls in the fundamental emission.

5.4 Test Setup Layout

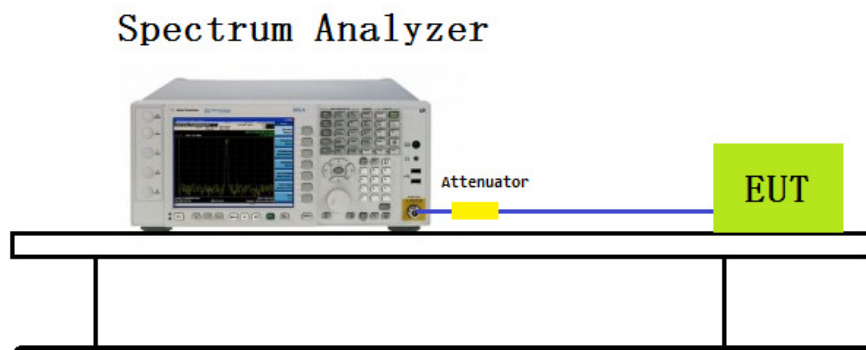



5.5 Test Result

Test Item	6dB Bandwidth Measurement
Test Engineer:	Chris
Test Date	2019-07-25
Test Mode	Transmitting by BLE

Channel No.	Frequency (MHz)	6dB Bandwidth (kHz)	Limit (kHz)	Result
0	2402	738.337	500	Pass
19	2440	740.886	500	Pass
39	2480	742.730	500	Pass

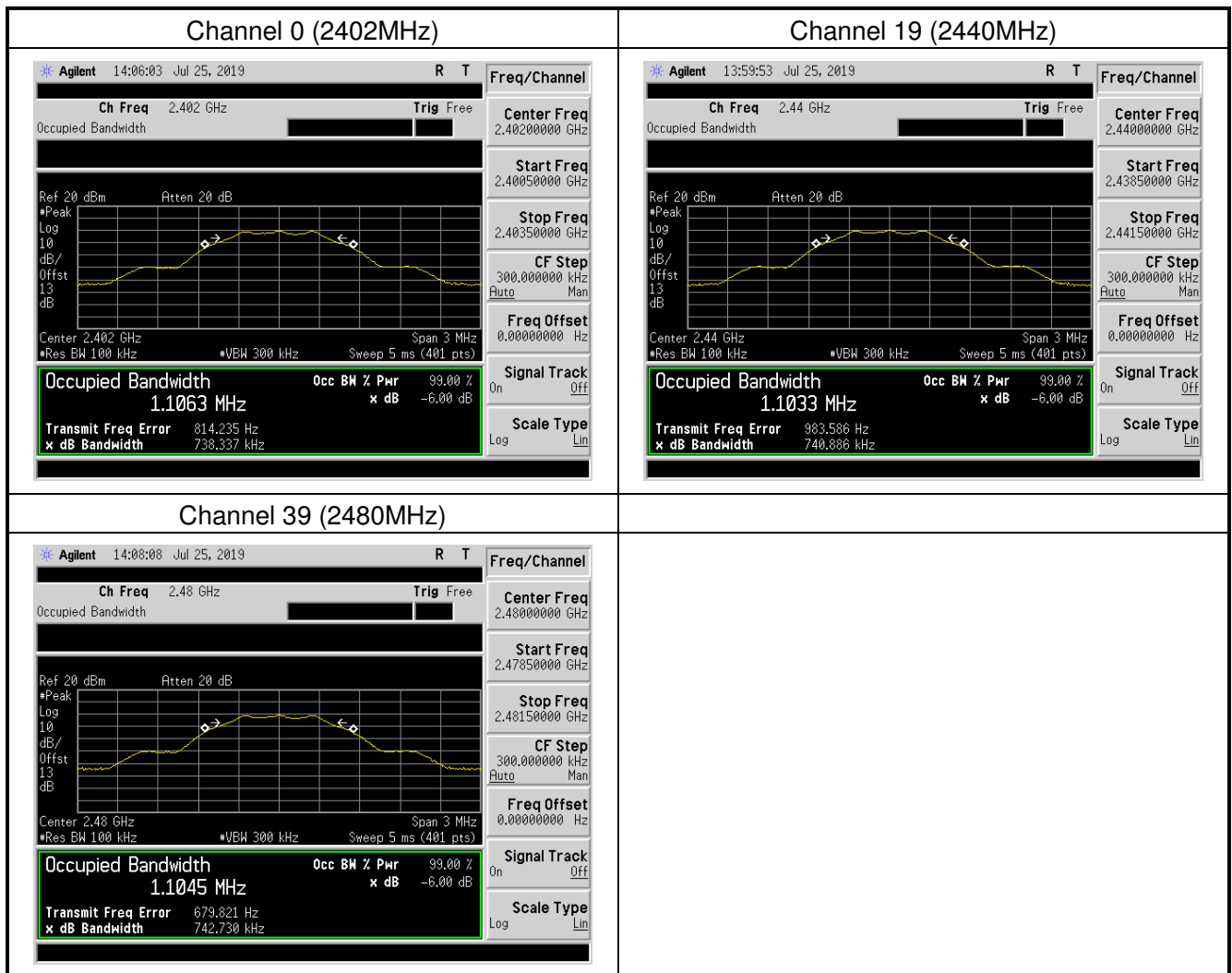



6. Conducted Output Power Measurement

6.1 Test Limit

According to FCC part15.247 (b) (3), for systems using digital modulation in the 902-928 MHz, 2400-2483.5 MHz, and 5725-5850MHz bands: 1 Watt. As an alternative to a peak power measurement, compliance with the one Watt limit can be based on a measurement of the maximum conducted output power. Maximum Conducted Output Power is defined as the total transmit power delivered to all antennas and antenna elements averaged across all symbols in the signaling alphabet when the transmitter is operating at its maximum power control level. Power must be summed across all antennas and antenna elements. The average must not include any time intervals during which the transmitter is off or is transmitting at a reduced power level. If multiple modes of operation are possible (e.g., alternative modulation methods), the maximum conducted output power is the highest total transmit power occurring in any mode.

Per RSS247 Issue 2 Section 5.4(d), for DTSs employing digital modulation techniques operating in the bands 902-928 MHz and 2400-2483.5 MHz, the maximum peak conducted output power shall not exceed 1W.

6.2 Test Standard

KDB 558074 D01v05r02 - Section 9.3.1.3 & Section 9.3.2.3

6.3 Test Procedures

Out power measurements were performed only when the EUT was transmitting at its maximum power control level using a broadband power meter with a pulse sensor. The pulse sensor employs a VBW = 50MHz so this method was only used for signals whose DTS bandwidth was less than or equal to 50MHz.

6.4 Test Setup Layout

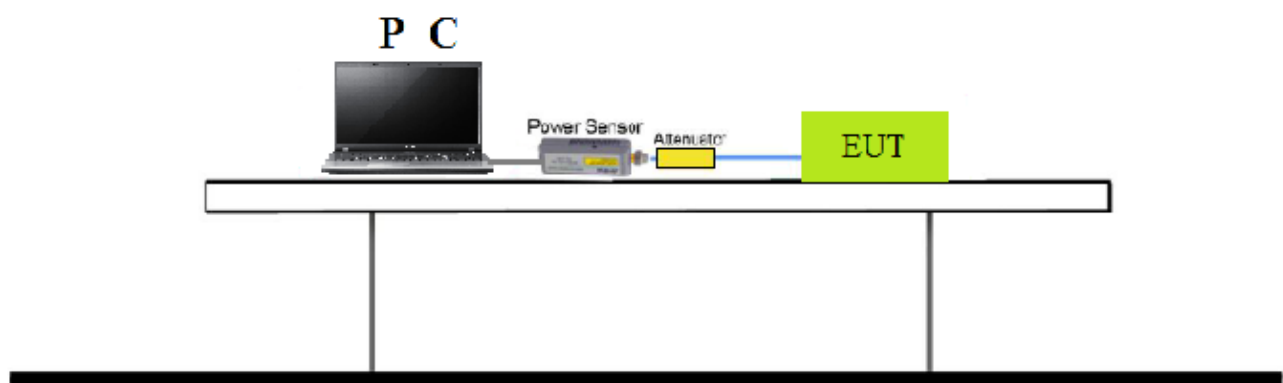



6.5 Test Result

Test Item	Conducted Output Power Measurement
Test Engineer:	Chris
Test Date	2019-07-27
Test Mode	Transmitting by BLE

Test Mode	Data Rate (Mbps)	Channel No.	Freq. (MHz)	Peak Power (dBm)	Limit (dBm)	Result
BLE	1	0	2402	-0.462	≤ 30	Pass
BLE	1	19	2440	0.154	≤ 30	Pass
BLE	1	39	2480	-0.743	≤ 30	Pass

Test Mode	Data Rate (Mbps)	Channel No.	Freq. (MHz)	Avg. Power (dBm)	Limit (dBm)	Result
BLE	1	0	2402	-2.919	≤ 30	Pass
BLE	1	19	2440	-2.381	≤ 30	Pass
BLE	1	39	2480	-3.222	≤ 30	Pass



7. Power Spectral Density Measurement

7.1 Test Limit

According to FCC part15.247 - Section (e), for digitally modulated systems, the power spectral density conducted from the intentional radiator to the antenna shall not be greater than 8 dBm in any 3 kHz band during any time interval of continuous transmission. This power spectral density shall be determined in accordance with the provisions of paragraph (b) of this section. The same method of determining the conducted output power shall be used to determine the power spectral density.

7.2 Test Standard

KDB 558074 D01v05r02- Section 8.4

7.3 Test Procedures

1. Set RBW=3kHz
2. Set RBW=10kHz
3. Span = 1.5 times the DTS channel bandwidth
4. Detector=Peak
5. Trace mode=Max hold
6. Sweep time=Auto couple
7. Allow the trace to stabilize
8. Analyzer was set to the center frequency of the DTS channel under investigation.

7.4 Test Setup Layout

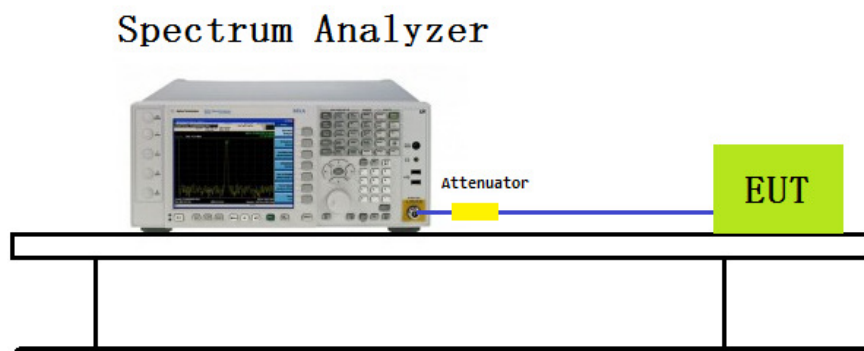



7.5 Test Result

Test Item	Power Spectral Density Measurement
Test Engineer:	Chris
Test Date	2019-07-25
Test Mode	Transmitting by BLE

Test Mode	Channel No.	Frequency(MHz)	Power Spectral Density (dBm/3kHz)	Limit (dBm/3kHz)	Result
BLE	0	2402	-14.64	8	Pass
	19	2440	-14.13	8	Pass
	39	2480	-14.97	8	Pass

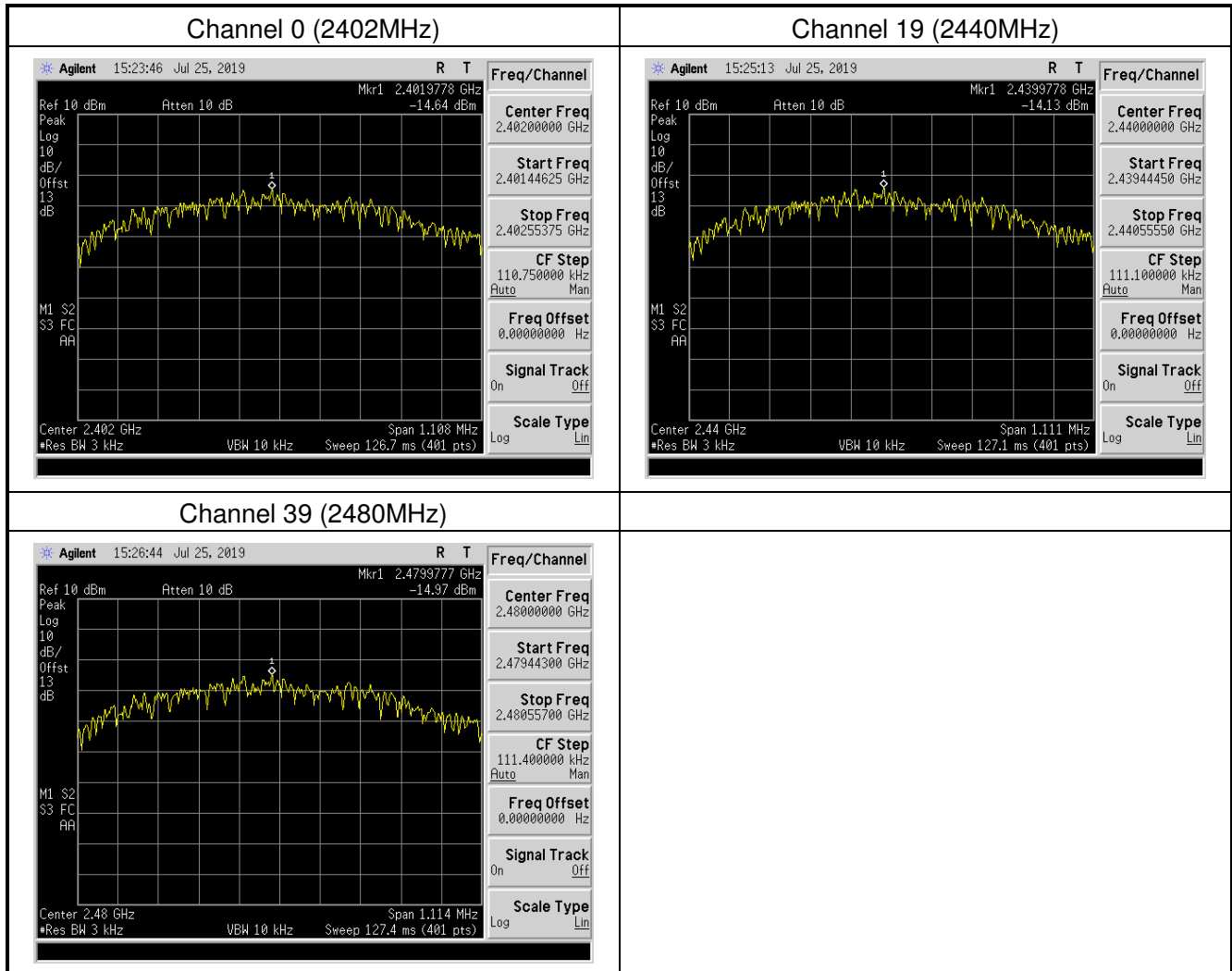



8. Conducted Band Edge and Out-of-Band Emissions Measurement

8.1 Test Limit

According to FCC part 15.247(d) , in any 100 kHz bandwidth outside the frequency band in which the spread spectrum or digitally modulated intentional radiator is operating, the radio frequency power that is produced by the intentional radiator shall be at least 20 dB below that in the 100 kHz bandwidth within the band that contains the highest level of the desired power, based on either an RF conducted or a radiated measurement, provided the transmitter demonstrates compliance with the peak conducted or a radiated measurement, provided the transmitter demonstrates compliance with the peak conducted power limits. If the transmitter complies with the conducted power limits based on the use of RMS averaging over a time interval, the attenuation required under this paragraph shall be 30 dB instead of 20 dB. Attenuation below the general limits specified in Section 15.209(a) of FCC part 15 is not required.

8.2 Test Standard

KDB 558074 D01v05r02 - Section 8.6 & Section 8.7



8.3 Test Procedures

Reference level measurement:

1. Set the RBW = 100 kHz
2. Set the VBW $\geq 3 \times$ RBW
3. Set the span to ≥ 1.5 times the DTS bandwidth
4. Detector = peak
5. Trace mode = max hold
6. Sweep time = auto couple
7. Allow trace to fully stabilize
8. Set instrument center frequency to DTS channel center frequency

Emission level measurement:

1. RBW = 100kHz
2. VBW = 300kHz
3. Detector = Peak
4. Trace mode = max hold
5. Sweep time = auto couple
6. The trace was allowed to stabilize
7. Set the center frequency and span to encompass frequency range to be measured

8.4 Test Setup Layout

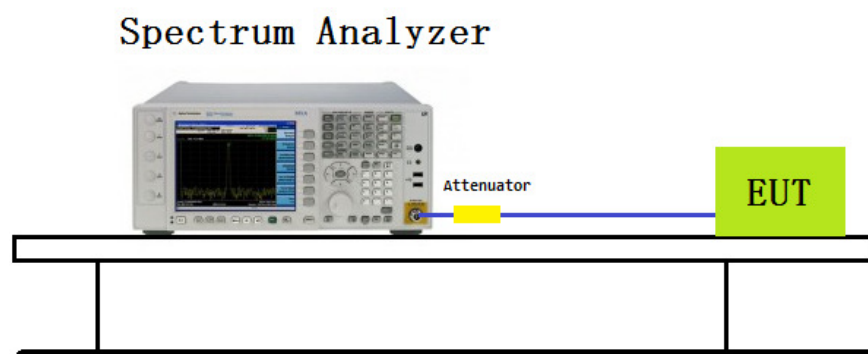



8.5 Test Result

Test Item	Conducted Band Edge and Out-of-Band Emissions Measurement
Test Engineer:	Chris
Test Date	2019-07-25
Test Mode	Transmitting by BLE

Test Mode	Channel No.	Frequency (MHz)	Limit	Result
BLE	0	2402	20dBc	Pass
	19	2440	20dBc	Pass
	39	2480	20dBc	Pass



Mode 1: Transmit by BLE (2402MHz)

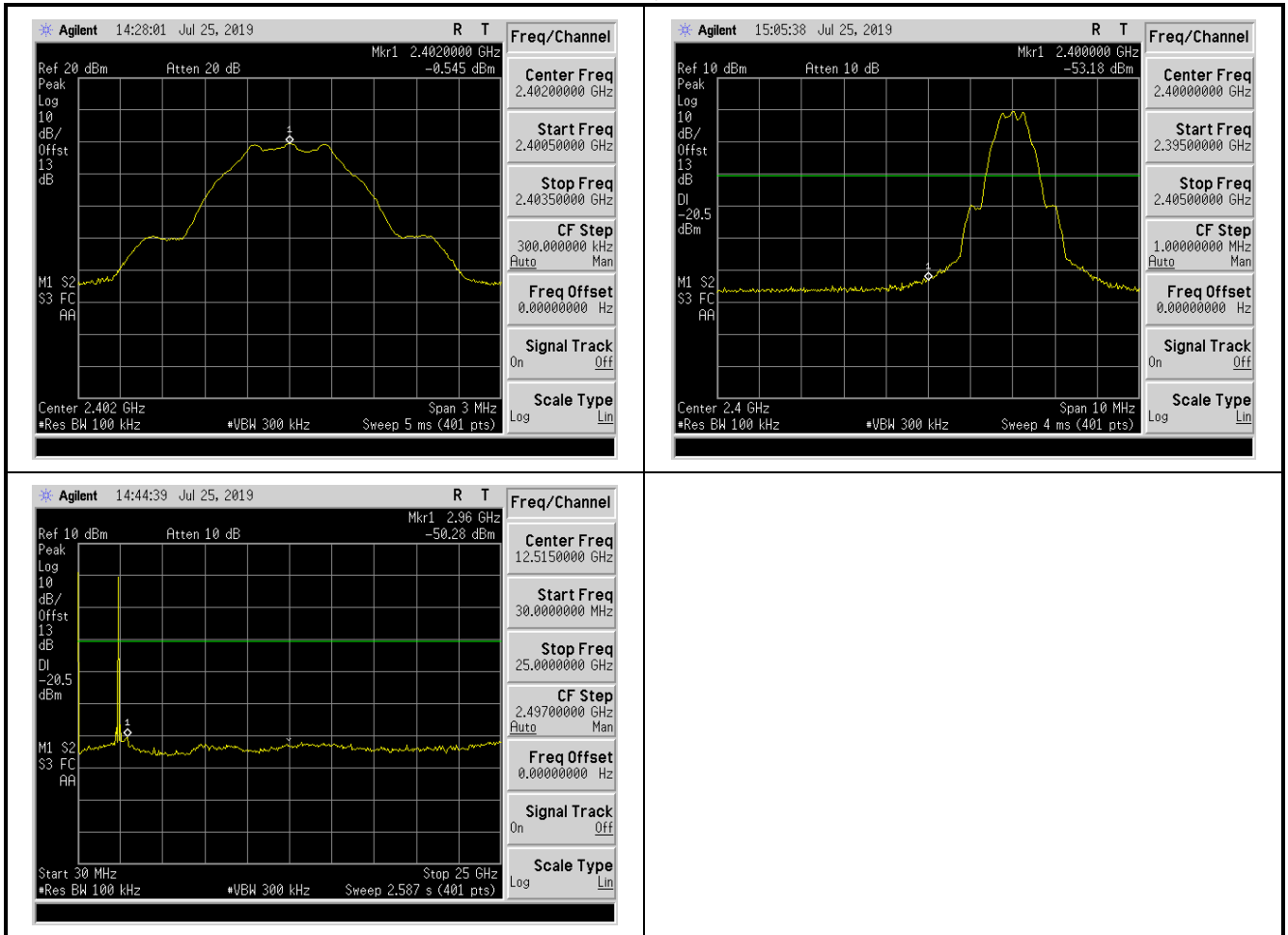

Mode 1: Transmit by BLE (2440MHz)

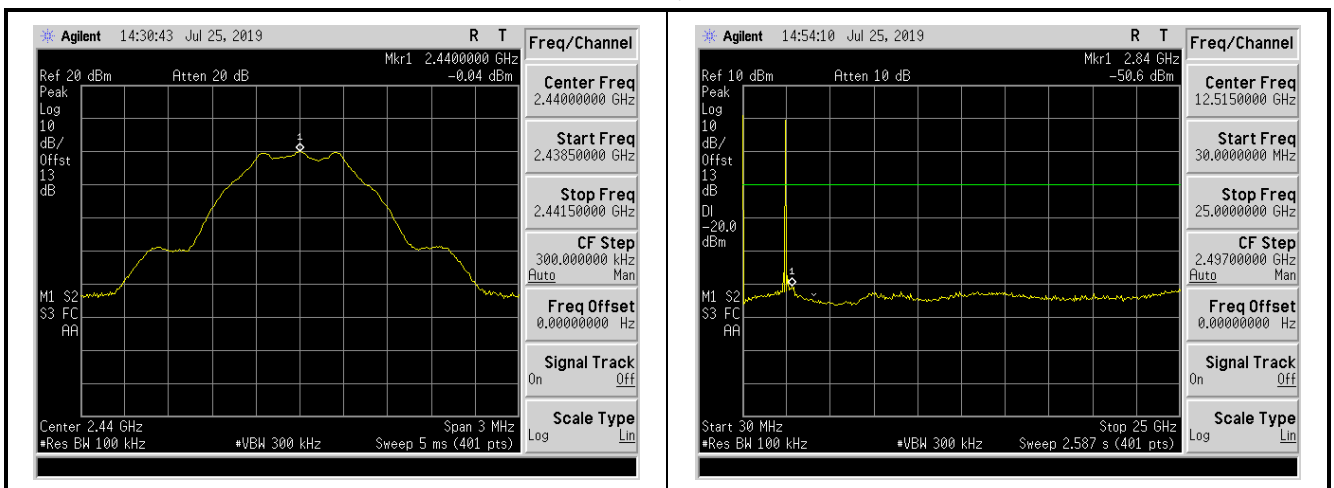



Mode 1: Transmit by BLE (2480MHz)

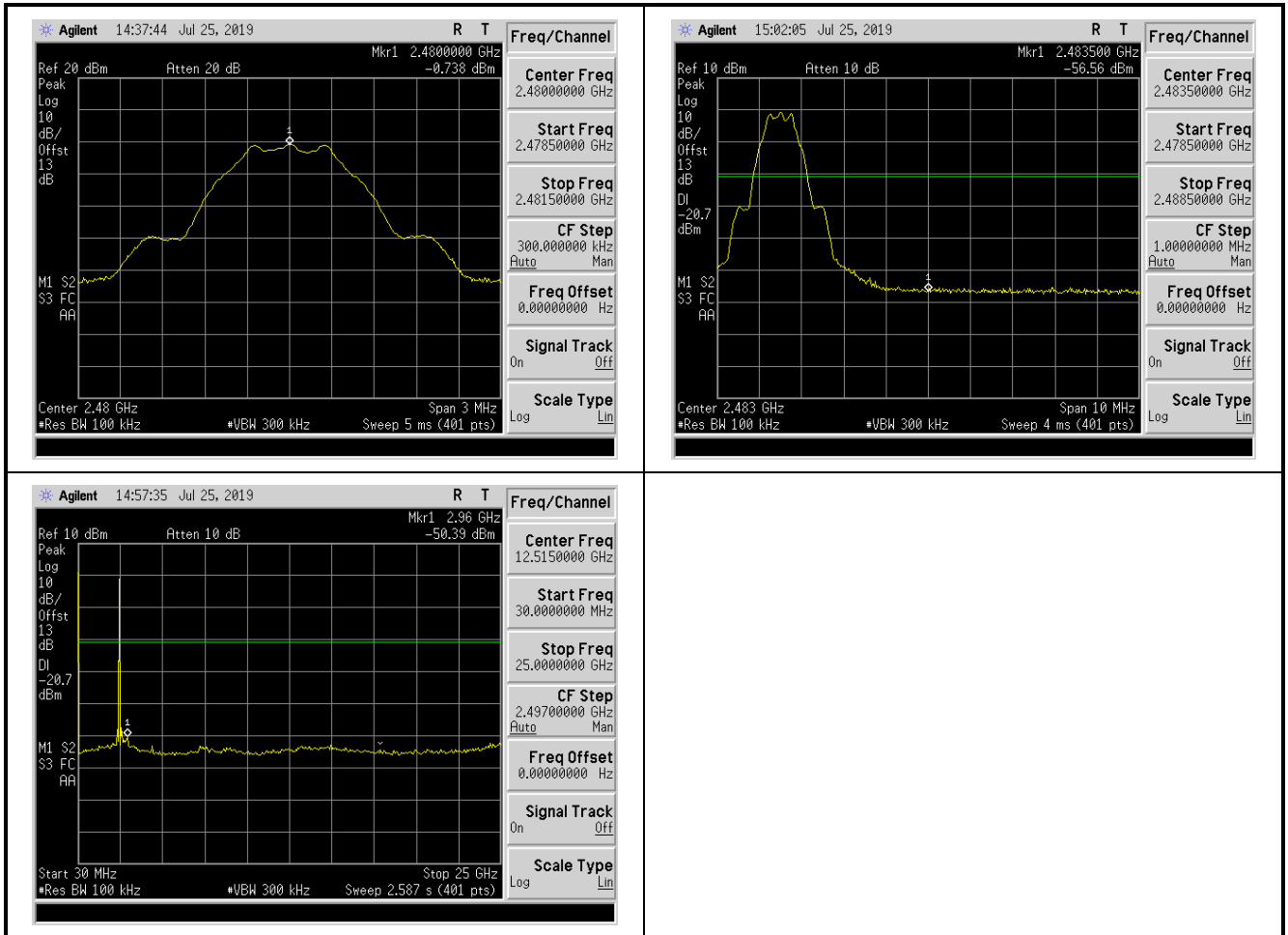



9. Radiated Emission Band Edge Measurement

9.1 Test Limit

Radiated emissions which fall in the restricted bands, as defined in Section 15.205(a) of FCC part 15, must also comply with the radiated emission limits specified in Section 15.209(a) of FCC part 15.

9.2 Test Standard

ANSI C63.10-2013 Section 6.10.5

9.3 Test Procedure

Peak Field Strength Measurements:

Analyzer center frequen was set to the frequency of the radiated spurious emission of interest

7. RBW=As specified in Table 1
8. VBW=3×RBW
9. Detector=Peak
10. Trace mode=Max hold
11. Sweep time=Auto couple
12. Allow the trace to stabilize

Table 1-RBW as a function of frequency

Frequency	RBW
9 ~ 150kHz	200 ~ 300Hz
0.15 ~ 30MHz	9 ~ 10kHz
30 ~ 1000MHz	100 ~ 120kHz
> 1000MHz	1MHz



AVE Field Strength Measurements:

Analyzer center frequency was set to the frequency of the radiated spurious emission of interest

7. RBW= 1MHz
8. VBW \geq 1/T
9. Detector=Peak
10. Trace mode=Max hold
11. Sweep time=Auto couple
12. Allow max hold to run for at least 50 times(1/duty cycle) trace

Do as an alternative, the instrument may be set to linear detector mode. Ensure that video filtering is applied in linear voltage domain (rather than in a log or dB domain). Some instruments require linear display mode in order to accomplish this. Others have a setting for Average-VBW Type, which can be set to "Voltage" regardless of the display mode

9.4 Test Setup Layout

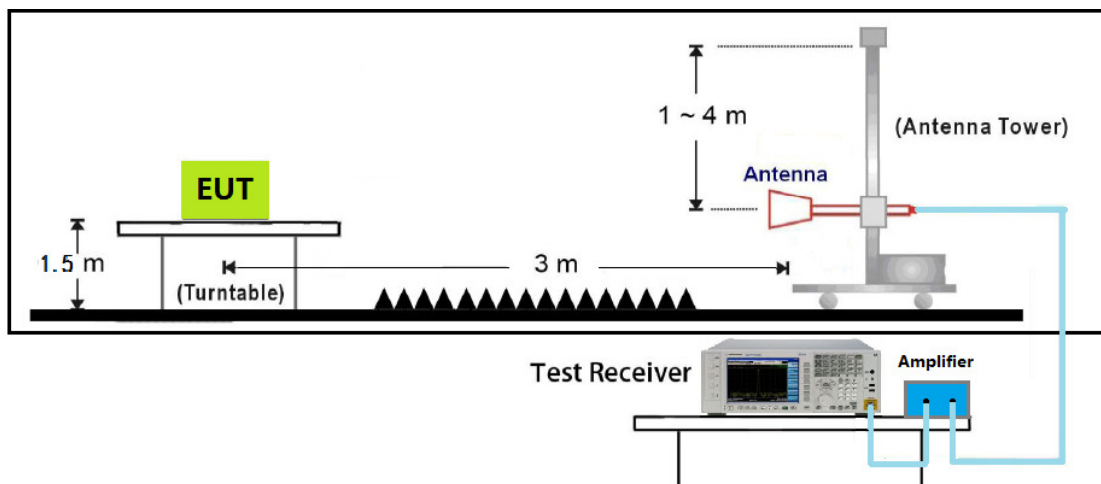



9.5 Test Result

Engineer: Chris	
Site: AC102	Time: 2019/07/30 - 22:32
Limit: FCC_Part15.209_RE(3m)	Margin: 0
Probe: N/A	Polarity: Horizontal
EUT: Tablet	Power: AC 120V/60Hz
Note: BLE 2402MHz	

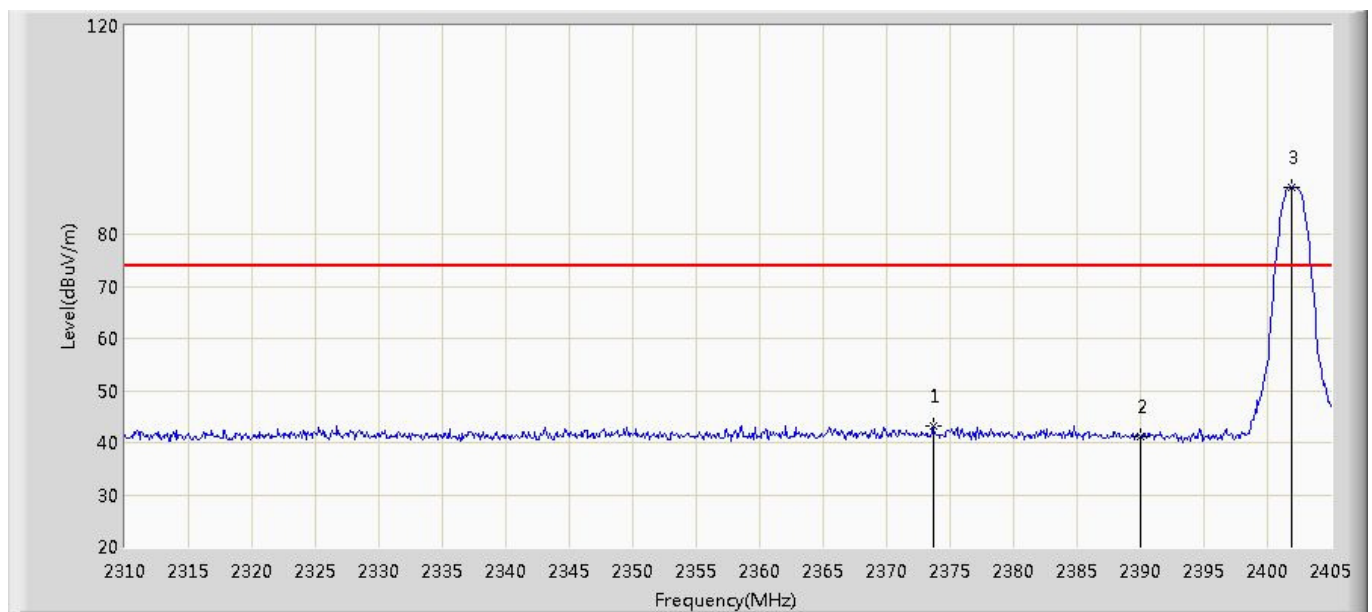

N o	Mar k	Frequency (MHz)	Measure Level (dBuV/m)	Reading Level (dBuV)	Over Limit (dB)	Limit (dBuV/m)	Factor (dB)	Type
1		2373.650	43.208	44.946	-30.792	74.000	-1.738	PK
2		2390.000	41.122	42.799	-32.878	74.000	-1.677	PK
3	*	2401.960	88.962	90.595	N/A	N/A	-1.633	PK

Note:

1. All Readings below 1GHz are Quasi-Peak, above are performed with peak and/or average measurements as necessary.
2. " * ", means this data is the worst emission level.
3. Measurement Level = Reading Level + Factor(Probe+Cable-Amp).



Engineer: Chris	
Site: AC102	Time: 2019/07/30 - 22:36
Limit: FCC_Part15.209_RE(3m)	Margin: 0
Probe: N/A	Polarity: Horizontal
EUT: Tablet	Power: AC 120V/60Hz
Note: BLE 2402MHz	

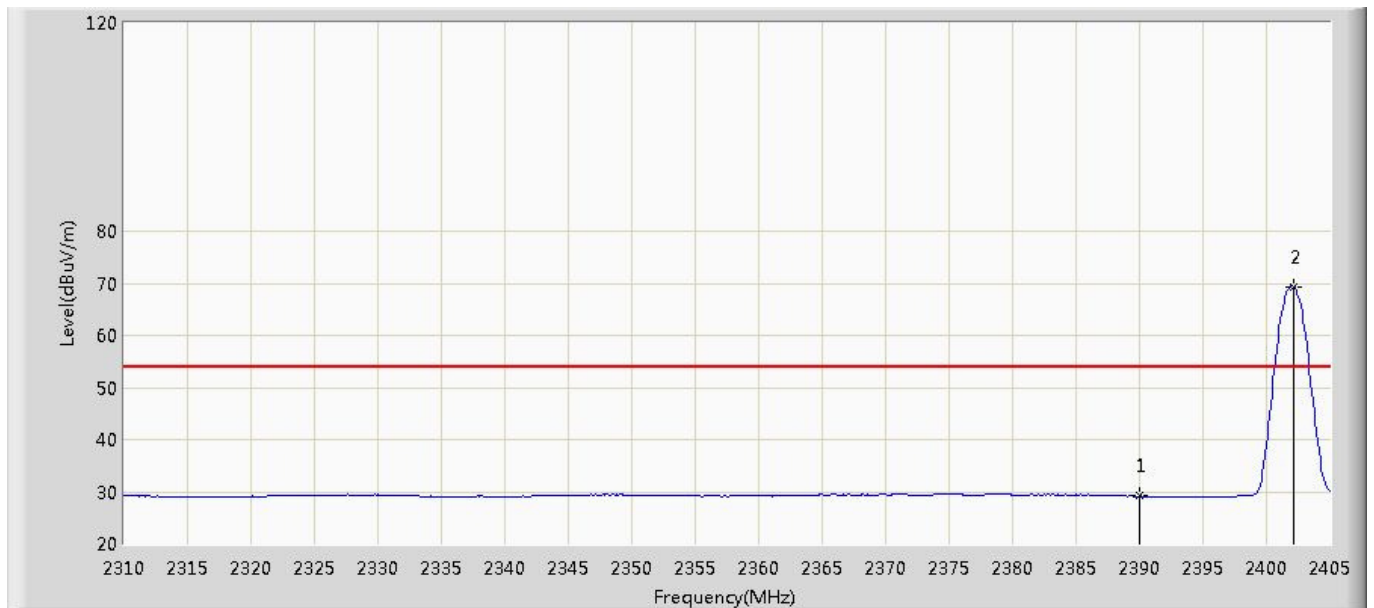

N	Mar	Frequency (MHz)	Measure Level (dBuV/m)	Reading Level (dBuV)	Over Limit (dB)	Limit (dBuV/m)	Factor (dB)	Type
1		2390.000	29.142	30.819	-24.858	54.000	-1.677	AV
2	*	2402.150	69.385	71.017	N/A	N/A	-1.632	AV

Note:

1. All Readings below 1GHz are Quasi-Peak, above are performed with peak and/or average measurements as necessary.
2. " * ", means this data is the worst emission level.
3. Measurement Level = Reading Level + Factor(Probe+Cable-Amp).



Engineer: Chris	
Site: AC102	Time: 2019/07/30 - 22:38
Limit: FCC_Part15.209_RE(3m)	Margin: 0
Probe: N/A	Polarity: Vertical
EUT: Tablet	Power: AC 120V/60Hz
Note: BLE 2402MHz	

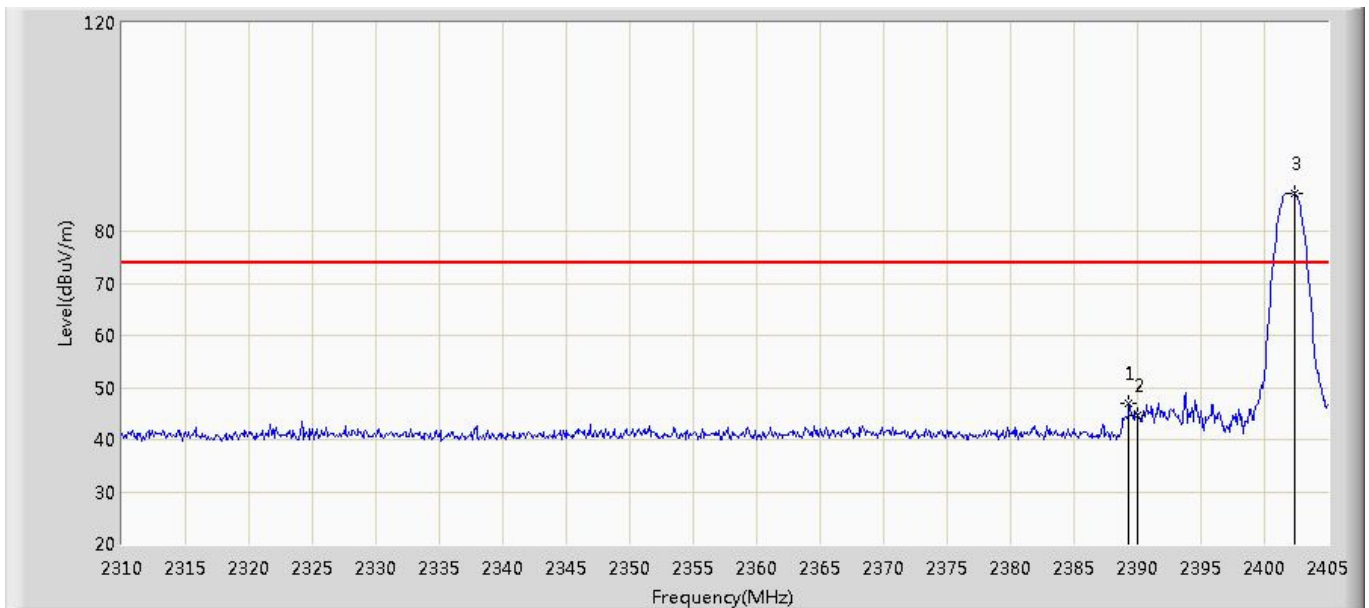

N o	Mar k	Frequency (MHz)	Measure Level (dBuV/m)	Reading Level (dBuV)	Over Limit (dB)	Limit (dBuV/m)	Factor (dB)	Type
1		2389.325	47.006	48.685	-26.994	74.000	-1.679	PK
2		2390.000	44.734	46.411	-29.266	74.000	-1.677	PK
3	*	2402.435	87.270	88.901	N/A	N/A	-1.631	PK

Note:

1. All Readings below 1GHz are Quasi-Peak, above are performed with peak and/or average measurements as necessary.
2. " * ", means this data is the worst emission level.
3. Measurement Level = Reading Level + Factor(Probe+Cable-Amp).



Engineer: Chris	
Site: AC102	Time: 2019/07/30 - 22:40
Limit: FCC_Part15.209_RE(3m)	Margin: 0
Probe: N/A	Polarity: Vertical
EUT: Tablet	Power: AC 120V/60Hz
Note: BLE 2402MHz	

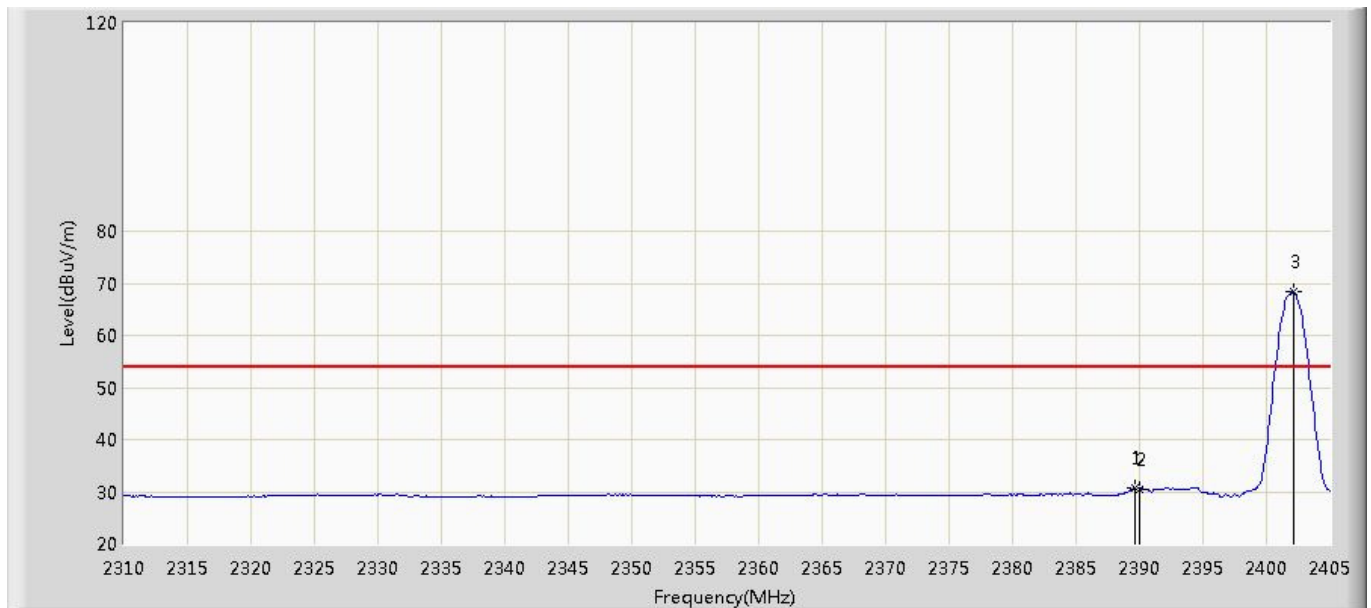

N	Mar	Frequency (MHz)	Measure Level (dBuV/m)	Reading Level (dBuV)	Over Limit (dB)	Limit (dBuV/m)	Factor (dB)	Type
1		2389.610	30.785	32.463	-23.215	54.000	-1.678	AV
2		2390.000	30.517	32.194	-23.483	54.000	-1.677	AV
3	*	2402.150	68.299	69.931	N/A	N/A	-1.632	AV

Note:

1. All Readings below 1GHz are Quasi-Peak, above are performed with peak and/or average measurements as necessary.
2. " * ", means this data is the worst emission level.
3. Measurement Level = Reading Level + Factor(Probe+Cable-Amp).



Engineer: Chris	
Site: AC102	Time: 2019/07/30 - 22:43
Limit: FCC_Part15.209_RE(3m)	Margin: 0
Probe: N/A	Polarity: Horizontal
EUT: Tablet	Power: AC 120V/60Hz
Note: BLE 2480MHz	

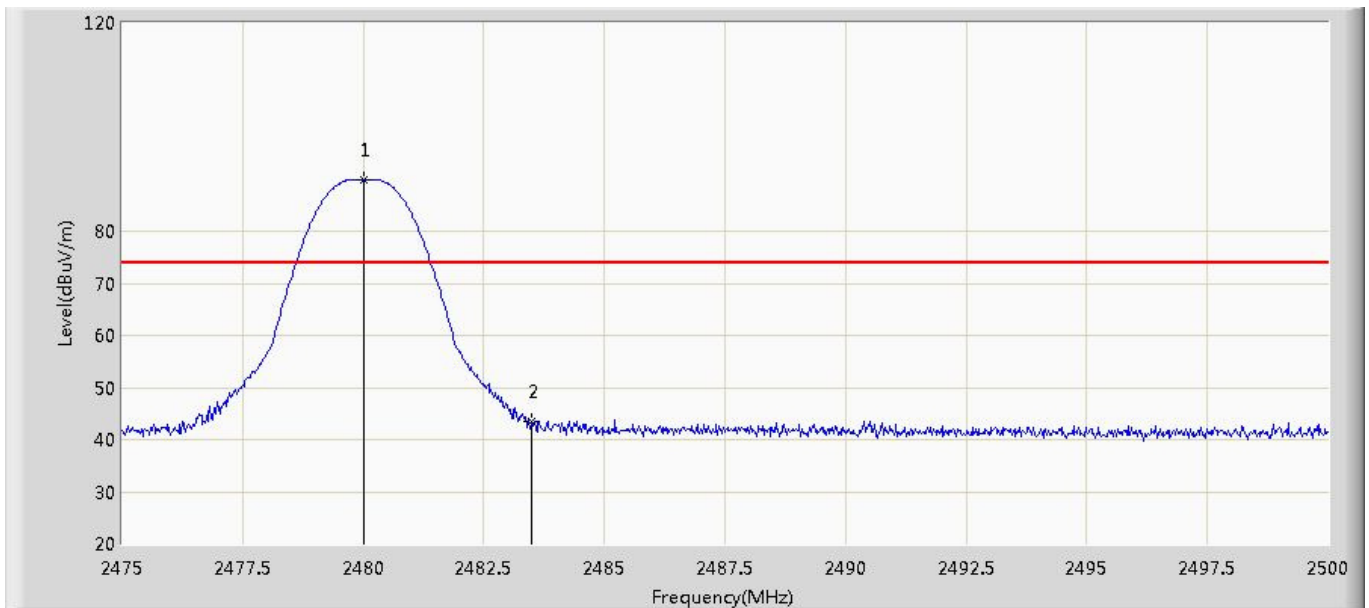

N	Mar	Frequency (MHz)	Measure Level (dBuV/m)	Reading Level (dBuV)	Over Limit (dB)	Limit (dBuV/m)	Factor (dB)	Type
1	*	2480.000	89.838	91.182	N/A	N/A	-1.344	PK
2		2483.500	43.591	44.922	-30.409	74.000	-1.331	PK

Note:

1. All Readings below 1GHz are Quasi-Peak, above are performed with peak and/or average measurements as necessary.
2. " * ", means this data is the worst emission level.
3. Measurement Level = Reading Level + Factor(Probe+Cable-Amp).



Engineer: Chris	
Site: AC102	Time: 2019/07/30 - 22:45
Limit: FCC_Part15.209_RE(3m)	Margin: 0
Probe: N/A	Polarity: Horizontal
EUT: Tablet	Power: AC 120V/60Hz
Note: BLE 2480MHz	



N	Mar	Frequency (MHz)	Measure Level (dBuV/m)	Reading Level (dBuV)	Over Limit (dB)	Limit (dBuV/m)	Factor (dB)	Type
1	*	2480.000	70.262	71.606	N/A	N/A	-1.344	AV
2		2483.500	30.474	31.805	-23.526	54.000	-1.331	AV

Note:

1. All Readings below 1GHz are Quasi-Peak, above are performed with peak and/or average measurements as necessary.
2. " * ", means this data is the worst emission level.
3. Measurement Level = Reading Level + Factor(Probe+Cable-Amp).



Engineer: Chris	
Site: AC102	Time: 2019/07/30 - 22:45
Limit: FCC_Part15.209_RE(3m)	Margin: 0
Probe: N/A	Polarity: Vertical
EUT: Tablet	Power: AC 120V/60Hz
Note: BLE 2480MHz	

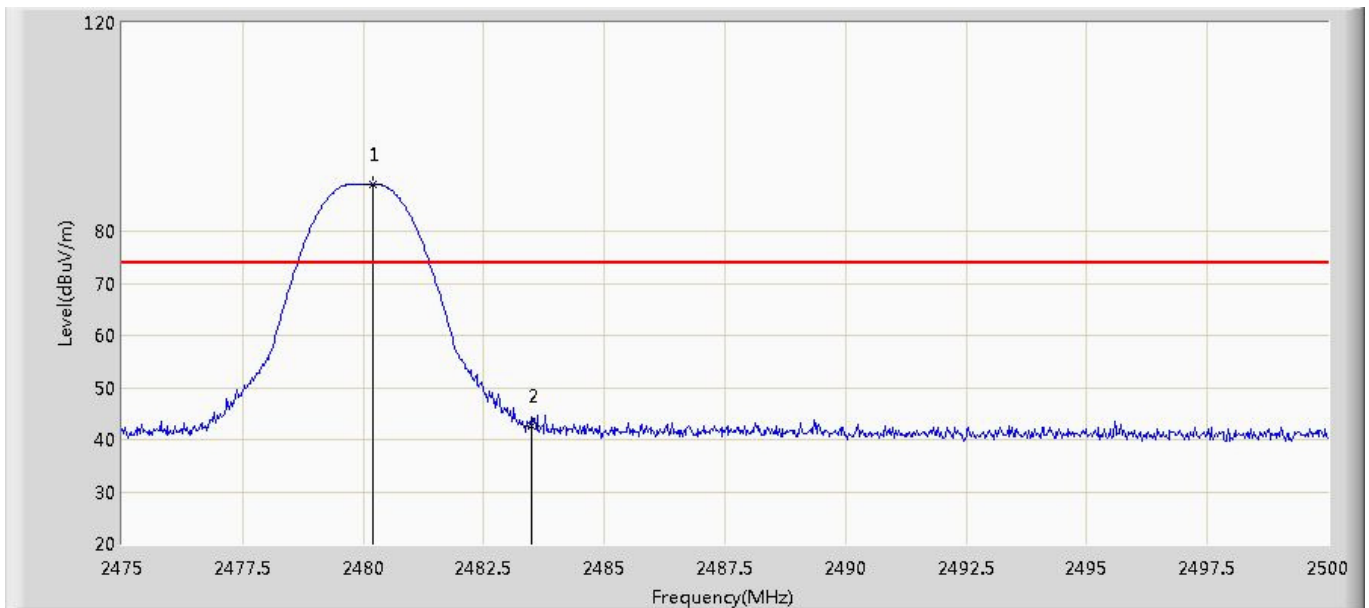

N	Mar	Frequency (MHz)	Measure Level (dBuV/m)	Reading Level (dBuV)	Over Limit (dB)	Limit (dBuV/m)	Factor (dB)	Type
1	*	2480.200	89.039	90.382	N/A	N/A	-1.343	PK
2		2483.500	42.560	43.891	-31.440	74.000	-1.331	PK

Note:

1. All Readings below 1GHz are Quasi-Peak, above are performed with peak and/or average measurements as necessary.
2. " * ", means this data is the worst emission level.
3. Measurement Level = Reading Level + Factor(Probe+Cable-Amp).



Engineer: Chris	
Site: AC102	Time: 2019/07/30 - 22:47
Limit: FCC_Part15.209_RE(3m)	Margin: 0
Probe:	Polarity: Vertical
EUT: Tablet	Power: AC 120V/60Hz
Note: BLE 2480MHz	

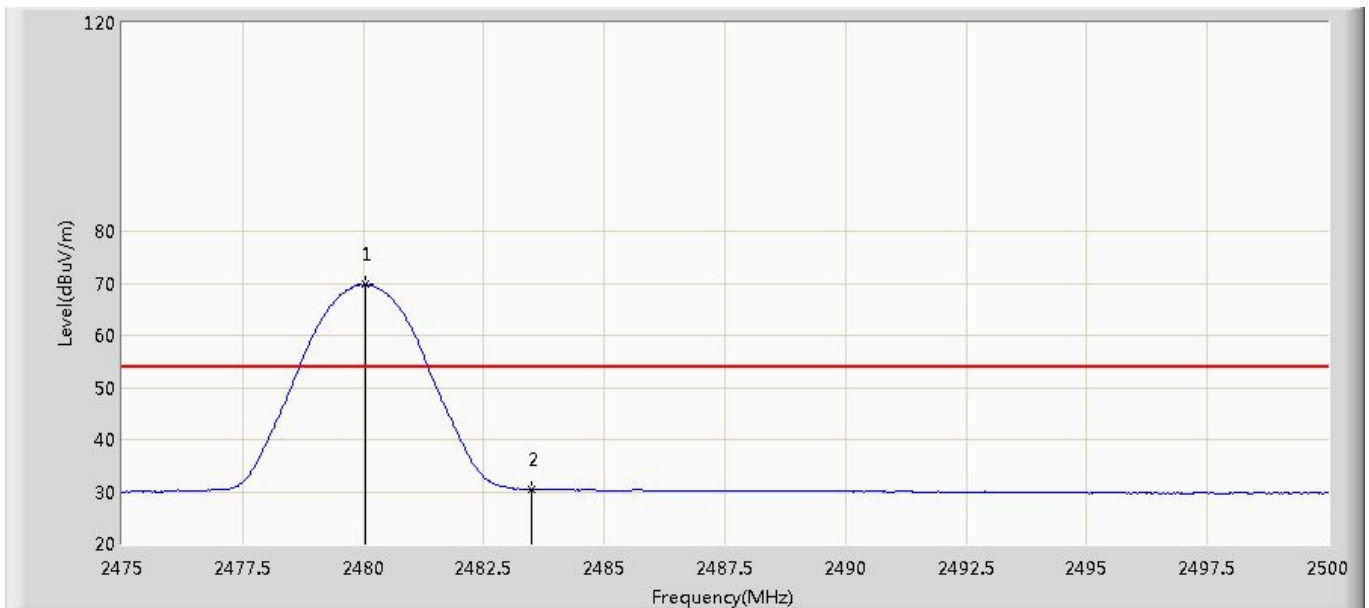

N	Mar	Frequency (MHz)	Measure Level (dBuV/m)	Reading Level (dBuV)	Over Limit (dB)	Limit (dBuV/m)	Factor (dB)	Type
1	*	2480.050	69.719	71.062	N/A	N/A	-1.343	AV
2		2483.500	30.513	31.844	-23.487	54.000	-1.331	AV

Note:

1. All Readings below 1GHz are Quasi-Peak, above are performed with peak and/or average measurements as necessary.
2. " * ", means this data is the worst emission level.
3. Measurement Level = Reading Level + Factor(Probe+Cable-Amp).

***** END OF REPORT *****