

FCC Test Report

Report No.: RF150618C15-3

FCC ID: P4Q-N496N

Test Model: N496N

Received Date: Jun. 18, 2015

Test Date: Jun. 26, 2015 ~ Aug. 20, 2015

Issued Date: Aug. 24, 2015

Applicant: MITAC International Corp.

Address: Building B, No. 209, Sec. 1, Nan Gang Rd., Nan Gang Dist., Taipei 11568, Taiwan, R.O.C.

Issued By: Bureau Veritas Consumer Products Services (H.K.) Ltd., Taoyuan Branch

Lab Address: No. 47-2, 14th Ling, Chia Pau Vil., Lin Kou Dist., New Taipei City, Taiwan (R.O.C)

Test Location (1): No. 19, Hwa Ya 2nd Rd, Wen Hwa Tsuen, Kwei Shan Hsiang, Taoyuan Hsien 333, Taiwan, R.O.C.



This report is for your exclusive use. Any copying or replication of this report to or for any other person or entity, or use of our name or trademark, is permitted only with our prior written permission. This report sets forth our findings solely with respect to the test samples identified herein. The results set forth in this report are not indicative or representative of the quality or characteristics of the lot from which a test sample was taken or any similar or identical product unless specifically and expressly noted. Our report includes all of the tests requested by you and the results thereof based upon the information that you provided to us. You have 60 days from date of issuance of this report to notify us of any material error or omission caused by our negligence, provided, however, that such notice shall be in writing and shall specifically address the issue you wish to raise. A failure to raise such issue within the prescribed time shall constitute your unqualified acceptance of the completeness of this report, the tests conducted and the correctness of the report contents. Unless specific mention, the uncertainty of measurement has been explicitly taken into account to declare the compliance or non-compliance to the specification. The report must not be used by the client to claim product certification, approval, or endorsement by TAF or any government agencies.

Table of Contents

Release Control Record	4
1 Certificate of Conformity	5
2 Summary of Test Results	6
2.1 Measurement Uncertainty.....	6
2.2 Modification Record	6
3 General Information	7
3.1 General Description of EUT.....	7
3.2 Description of Test Modes.....	9
3.2.1 Test Mode Applicability and Tested Channel Detail.....	11
3.3 Duty Cycle of Test Signal.....	13
3.4 Description of Support Units.....	17
3.4.1 Configuration of System under Test	17
3.5 General Description of Applied Standards.....	17
4 Test Types and Results	18
4.1 Radiated Emission and Bandedge Measurement	18
4.1.1 Limits of Radiated Emission and Bandedge Measurement	18
4.1.2 Limits of Unwanted Emission Out of The Restricted Bands.....	18
4.1.3 Test Instruments	19
4.1.4 Test Procedures.....	20
4.1.5 Deviation from Test Standard	20
4.1.6 Test Set Up	21
4.1.7 EUT Operating Conditions.....	21
4.1.8 Test Results	22
4.2 Conducted Emission Measurement.....	67
4.2.1 Limits of Conducted Emission Measurement	67
4.2.2 Test Instruments	67
4.2.3 Test Procedures.....	68
4.2.4 Deviation from Test Standard	68
4.2.5 Test Setup.....	68
4.2.6 EUT Operating Conditions.....	68
4.2.7 Test Results	69
4.3 Transmit Power Measurement.....	73
4.3.1 Limits of Transmit Power Measurement	73
4.3.2 Test Setup.....	73
4.3.3 Test Instruments	74
4.3.4 Test Procedure	74
4.3.5 Deviation from Test Standard	74
4.3.6 EUT Operating Conditions.....	74
4.3.7 Test Result	75
4.4 Peak Power Spectral Density Measurement.....	80
4.4.1 Limits of Peak Power Spectral Density Measurement	80
4.4.2 Test Setup.....	80
4.4.3 Test Instruments	80
4.4.4 Test Procedures.....	81
4.4.5 Deviation from Test Standard	81
4.4.6 EUT Operating Conditions.....	81
4.4.7 Test Results	82
4.5 Frequency Stability	87
4.5.1 Limit of Frequency Stability Measurement	87
4.5.2 Test Setup.....	87
4.5.3 Test Instruments	87
4.5.4 Test Procedure	87
4.5.5 Deviation from Test Standard	87



4.5.6 EUT Operating Condition	87
4.5.7 Test Results	88
4.6 6dB Bandwidth Measurement.....	89
4.6.1 Limits of 6dB Bandwidth Measurement.....	89
4.6.2 Test Setup.....	89
4.6.3 Test Instruments	89
4.6.4 Test Procedure	89
4.6.5 Deviation from Test Standard	89
4.6.6 EUT Operating Condition	89
4.6.7 Test Results	90
5 Pictures of Test Arrangements	92
Appendix – Information on the Testing Laboratories	93



A D T

Release Control Record

Issue No.	Description	Date Issued
RF150618C15-3	Original Release	Aug. 24, 2015



1 Certificate of Conformity

Product: Tablet

Brand: MITAC, Mio, MAGELLAN, NAVMAN, MioCARE, MioWORK

Test Model: N496N

Sample Status: Production Unit

Applicant: MITAC International Corp.

Test Date: Jun. 26, 2015 ~ Aug. 20, 2015

Standards: 47 CFR FCC Part 15, Subpart E (Section 15.407)
ANSI C63.10:2013

The above equipment has been tested by **Bureau Veritas Consumer Products Services (H.K.) Ltd., Taoyuan Branch**, and found compliance with the requirement of the above standards. The test record, data evaluation & Equipment Under Test (EUT) configurations represented herein are true and accurate accounts of the measurements of the sample's EMC characteristics under the conditions specified in this report.

Prepared by : _____

Vera Huang

Date: _____

Aug. 24, 2015

Vera Huang / Specialist

Approved by : _____

Kay Wu

Date: _____

Aug. 24, 2015

Kay Wu / Supervisor

2 Summary of Test Results

47 CFR FCC Part 15, Subpart E (SECTION 15.407)			
FCC Clause	Test Item	Result	Remarks
15.407(b)(6)	AC Power Conducted Emissions	PASS	Meet the requirement of limit. Minimum passing margin is -8.04dB at 0.19717MHz.
15.407(b)(1/2/3/4/6)	Radiated Emissions & Band Edge Measurement	PASS	Meet the requirement of limit. Minimum passing margin is -2.01dB at 5470MHz.
15.407(a)(1/2/3)	Max Average Transmit Power	PASS	Meet the requirement of limit.
15.407(a)(1/2/3)	Peak Power Spectral Density	PASS	Meet the requirement of limit.
15.407(e)	6dB bandwidth	PASS	Meet the requirement of limit. (U-NII-3 Band only)
15.407(g)	Frequency Stability	PASS	Meet the requirement of limit.
15.203	Antenna Requirement	PASS	No antenna connector is used.

2.1 Measurement Uncertainty

Where relevant, the following measurement uncertainty levels have been estimated for tests performed on the EUT as specified in CISPR 16-4-2:

Measurement	Frequency	Expanded Uncertainty (k=2) (±)
Conducted Emissions at mains ports	150kHz ~ 30MHz	2.44 dB
Radiated Emissions up to 1 GHz	30MHz ~ 200MHz	2.93 dB
	200MHz ~ 1000MHz	2.95 dB
Radiated Emissions above 1 GHz	1GHz ~ 18GHz	2.26 dB
	18GHz ~ 40GHz	1.94 dB

2.2 Modification Record

There were no modifications required for compliance.

3 General Information

3.1 General Description of EUT

Product	Tablet
Brand	MiTAC, Mio, MAGELLAN, NAVMAN, MioCARE, MioWORK
Test Model	N496N
Power Supply Rating	5.0Vdc (adapter or host equipment) 3.7Vdc (Li-ion battery)
Modulation Type	64QAM, 16QAM, QPSK, BPSK
Modulation Technology	OFDM
Transfer Rate	802.11a: 54.0/ 48.0/ 36.0/ 24.0/ 18.0/ 12.0/ 9.0/ 6.0Mbps 802.11n: up to MCS7
Operating Frequency	5180 ~ 5240MHz, 5260 ~ 5320MHz, 5500 ~ 5700MHz, 5745 ~ 5825MHz
Number of Channel	5180 ~ 5240MHz: 4 for 802.11a, 802.11n (20MHz) 2 for 802.11n (40MHz) 5260 ~ 5320MHz: 4 for 802.11a, 802.11n (20MHz) 2 for 802.11n (40MHz) 5500 ~ 5700MHz: 8 for 802.11a, 802.11n (20MHz) 3 for 802.11n (40MHz) 5745 ~ 5825MHz: 5 for 802.11a, 802.11n (20MHz) 2 for 802.11n (40MHz)
Output Power	40.93mW for 5180 ~ 5240MHz 38.28mW for 5260 ~ 5320MHz 33.42mW for 5500 ~ 5700MHz 30.97mW for 5745 ~ 5825MHz
Antenna Type	PIFA antenna with 2.5dBi gain (5180 ~ 5240MHz) PIFA antenna with 2.5dBi gain (5260 ~ 5320MHz) PIFA antenna with 0.6dBi gain (5500 ~ 5700MHz) PIFA antenna with 0.8dBi gain (5745 ~ 5825MHz)
Antenna Connector	{ antenna connector }
Accessory Device	Refer to Note as below
Data Cable Supplied	Refer to Note as below

Note:

1. The EUT provides one completed transmitter and one receiver.

Modulation Mode	Tx Function
802.11a	1TX
802.11n (20MHz)	1TX
802.11n (40MHz)	1TX

2. The EUT contains following accessory devices.

Product	Brand	Model	Description
Adapter	TPT	MIL050200I	I/P: 100-240Vac, 50/60Hz, 0.6A O/P: 5Vdc, 2A
Battery	TianYu	N496	3.7Vdc, 4000mAh
USB Cable	EMINENCE	N/A	0.9m cable
WLAN, BT Module	Jorjin	WG7833-B0	--

3. There are 2 configurations for the EUT which listed as below.

Main Sample (A): Ulmo Pro advance_fleet

2nd Sample (B): Ulmo Pro regular

4. The above EUT information is declared by manufacturer and for more detailed features description, please refer to the manufacturer's specifications or user's manual.

3.2 Description of Test Modes

FOR 5180 ~ 5240MHz

4 channels are provided for 802.11a, 802.11n (20MHz):

Channel	Frequency	Channel	Frequency
36	5180 MHz	44	5220 MHz
40	5200 MHz	48	5240 MHz

2 channels are provided for 802.11n (40MHz):

Channel	Frequency	Channel	Frequency
38	5190 MHz	46	5230 MHz

FOR 5260 ~ 5320MHz

4 channels are provided for 802.11a, 802.11n (20MHz):

Channel	Frequency	Channel	Frequency
52	5260 MHz	60	5300 MHz
56	5280 MHz	64	5320 MHz

2 channels are provided for 802.11n (40MHz):

Channel	Frequency	Channel	Frequency
54	5270 MHz	62	5310 MHz

FOR 5500 ~ 5700MHz

11 channels are provided for 802.11a, 802.11n (20MHz):

Channel	Frequency	Channel	Frequency
100	5500 MHz	124	5620 MHz
104	5520 MHz	128	5640 MHz
108	5540 MHz	132	5660 MHz
112	5560 MHz	136	5680 MHz
116	5580 MHz	140	5700 MHz
120	5600 MHz		

5 channels are provided for 802.11n (40MHz):

Channel	Frequency	Channel	Frequency
102	5510 MHz	126	5630 MHz
110	5550 MHz	134	5670 MHz
118	5590 MHz		

FOR 5745 ~ 5825MHz:

5 channels are provided for 802.11a, 802.11n (20MHz):

Channel	Frequency	Channel	Frequency
149	5745MHz	161	5805MHz
153	5765MHz	165	5825MHz
157	5785MHz		

2 channels are provided for 802.11n (40MHz):

Channel	Frequency	Channel	Frequency
151	5755MHz	159	5795MHz

3.2.1 Test Mode Applicability and Tested Channel Detail

EUT Configure Mode	Applicable To				Description
	RE \geq 1G	RE $<$ 1G	PLC	APCM	
A	√	√	√	√	Sample A
B	√	√	√	-	Sample B

Where **RE \geq 1G**: Radiated Emission above 1GHz **RE $<$ 1G**: Radiated Emission below 1GHz
PLC: Power Line Conducted Emission **APCM**: Antenna Port Conducted Measurement

NOTE:

- The EUT had been pre-tested on the positioned of each 3 axis. The worst case was found when positioned on **X-plane** for 5180-5240MHz, 5260-5320MHz, 5745-5825MHz, and **Y-plane** for 5500-5700MHz.
- "-" means no effect.

Radiated Emission Test (Above 1GHz):

- Pre-Scan has been conducted to determine the worst-case mode from all possible combinations between available modulations, data rates and antenna ports (if EUT with antenna diversity architecture).
- Following channel(s) was (were) selected for the final test as listed below.

EUT Configure Mode	Mode	Frequency Band (MHz)	Available Channel	Tested Channel	Modulation Technology	Modulation Type	Data Rate (Mbps)
A	802.11a	5180-5240	36 to 48	36, 40, 48	OFDM	BPSK	6.0
	802.11n (20MHz)		36 to 48	36, 40, 48	OFDM	BPSK	MCS0
	802.11n (40MHz)		38 to 46	38, 46	OFDM	BPSK	MCS0
	802.11a	5260-5320	52 to 64	52, 60, 64	OFDM	BPSK	6.0
	802.11n (20MHz)		52 to 64	52, 60, 64	OFDM	BPSK	MCS0
	802.11n (40MHz)		54 to 62	54, 62	OFDM	BPSK	MCS0
	802.11a	5500-5700	100 to 140	100, 116, 140	OFDM	BPSK	6.0
	802.11n (20MHz)		100 to 140	100, 116, 140	OFDM	BPSK	MCS0
	802.11n (40MHz)		102 to 134	102, 110, 134	OFDM	BPSK	MCS0
	802.11a	5745-5825	149 to 165	149, 157, 165	OFDM	BPSK	6.0
802.11n (20MHz)	149 to 165		149, 157, 165	OFDM	BPSK	MCS0	
802.11n (40MHz)	151 to 159		151, 159	OFDM	BPSK	MCS0	
B	802.11n (40MHz)	5180-5240	38 to 46	38	OFDM	BPSK	6.0
	802.11n (40MHz)	5260-5320	54 to 62	62	OFDM	BPSK	6.0
	802.11n (40MHz)	5500-5700	102 to 134	102	OFDM	BPSK	6.0
	802.11n (40MHz)	5745-5825	151 to 159	151	OFDM	BPSK	6.0

Radiated Emission Test (Below 1GHz):

- Pre-Scan has been conducted to determine the worst-case mode from all possible combinations between available modulations, data rates and antenna ports (if EUT with antenna diversity architecture).
- Following channel(s) was (were) selected for the final test as listed below.

EUT Configure Mode	Mode	Frequency Band (MHz)	Available Channel	Tested Channel	Modulation Technology	Modulation Type	Data Rate (Mbps)
A, B	802.11n (40MHz)	5180-5240	38 to 46	38	OFDM	BPSK	6.0
	802.11n (40MHz)	5260-5320	54 to 62	62	OFDM	BPSK	6.0
	802.11n (40MHz)	5500-5700	102 to 134	102	OFDM	BPSK	6.0
	802.11n (40MHz)	5745-5825	151 to 159	151	OFDM	BPSK	6.0

Power Line Conducted Emission Test:

- Pre-Scan has been conducted to determine the worst-case mode from all possible combinations between available modulations, data rates and antenna ports (if EUT with antenna diversity architecture).
- Following channel(s) was (were) selected for the final test as listed below.

EUT Configure Mode	Mode	Frequency Band (MHz)	Available Channel	Tested Channel	Modulation Technology	Modulation Type	Data Rate (Mbps)
A, B	802.11n (40MHz)	5500-5700	102 to 134	102	OFDM	BPSK	6.0

Antenna Port Conducted Measurement:

- This item includes all test value of each mode, but only includes spectrum plot of worst value of each mode.
- Pre-Scan has been conducted to determine the worst-case mode from all possible combinations between available modulations, data rates and antenna ports (if EUT with antenna diversity architecture).
- Following channel(s) was (were) selected for the final test as listed below.

EUT Configure Mode	Mode	Frequency Band (MHz)	Available Channel	Tested Channel	Modulation Technology	Modulation Type	Data Rate (Mbps)
A	802.11a	5180-5240	36 to 48	36, 40, 48	OFDM	BPSK	6.0
	802.11n (20MHz)		36 to 48	36, 40, 48	OFDM	BPSK	MCS0
	802.11n (40MHz)		38 to 46	38, 46	OFDM	BPSK	MCS0
	802.11a	5260-5320	52 to 64	52, 60, 64	OFDM	BPSK	6.0
	802.11n (20MHz)		52 to 64	52, 60, 64	OFDM	BPSK	MCS0
	802.11n (40MHz)		54 to 62	54, 62	OFDM	BPSK	MCS0
	802.11a	5500-5700	100 to 140	100, 116, 140	OFDM	BPSK	6.0
	802.11n (20MHz)		100 to 140	100, 116, 140	OFDM	BPSK	MCS0
	802.11n (40MHz)		102 to 134	102, 110, 134	OFDM	BPSK	MCS0
	802.11a	5745-5825	149 to 165	149, 157, 165	OFDM	BPSK	6.0
	802.11n (20MHz)		149 to 165	149, 157, 165	OFDM	BPSK	MCS0
	802.11n (40MHz)		151 to 159	151, 159	OFDM	BPSK	MCS0

Test Condition:

Applicable To	Environmental Conditions	Input Power	Tested by
RE \geq 1G	25deg. C, 65%RH	120Vac, 60Hz	Anson Lin
RE<1G	25deg. C, 65%RH	120Vac, 60Hz	Anson Lin
PLC	25deg. C, 68%RH	120Vac, 60Hz	Toby Tian
APCM	25deg. C, 68%RH	3.7Vdc	Carlos Chen

3.3 Duty Cycle of Test Signal

MODULATION TYPE: BPSK

Duty cycle of test signal is < 98%, duty factor is required.

802.11a: Duty cycle = $1.390/1.680 = 0.827$, Duty factor = $10 * \log(1/0.827) = 0.82$

802.11n (20MHz): Duty cycle = $1.300/1.590 = 0.818$, Duty factor = $10 * \log(1/0.818) = 0.87$

802.11n (40MHz): Duty cycle = $605.00/905.00 = 0.669$, Duty factor = $10 * \log(1/0.669) = 1.75$



MODULATION TYPE: QPSK

Duty cycle of test signal is < 98%, duty factor is required.

802.11a: Duty cycle = $690.00/975.00 = 0.708$, Duty factor = $10 * \log(1/0.708) = 1.50$

802.11n (20MHz): Duty cycle = $660.00/940.00 = 0.702$, Duty factor = $10 * \log(1/0.702) = 1.54$

802.11n (40MHz): Duty cycle = $295.00/605.00 = 0.488$, Duty factor = $10 * \log(1/0.488) = 3.12$



MODULATION TYPE: 16QAM

Duty cycle of test signal is < 98%, duty factor is required.

802.11a: Duty cycle = 350.00/630.00 = 0.556, Duty factor = $10 * \log(1/0.556) = 2.55$

802.11n (20MHz): Duty cycle = 330.00/615.00 = 0.537, Duty factor = $10 * \log(1/0.537) = 2.70$

802.11n (40MHz): Duty cycle = 175.00/445.00 = 0.393, Duty factor = $10 * \log(1/0.393) = 4.06$



MODULATION TYPE: 64QAM

Duty cycle of test signal is < 98%, duty factor is required.

802.11a: Duty cycle = 175.00/450.00 = 0.389, Duty factor = $10 * \log(1/0.389) = 4.10$

802.11n (20MHz): Duty cycle = 180.00/450.00 = 0.400, Duty factor = $10 * \log(1/0.400) = 3.98$

802.11n (40MHz): Duty cycle = 65.00/365.00 = 0.178, Duty factor = $10 * \log(1/0.178) = 7.50$



3.4 Description of Support Units

The EUT has been tested as an independent unit together with other necessary accessories or support units. The following support units or accessories were used to form a representative test configuration during the tests.

No.	Product	Brand	Model No.	Serial No.	FCC ID
A.	Earphone	N/A	N/A	N/A	N/A

Note:

- All power cords of the above support units are non-shielded (1.8m).

No.	Signal Cable Description Of The Above Support Units
1.	N/A

Note:

- All power cords of the above support units are non-shielded (1.8m).

3.4.1 Configuration of System under Test

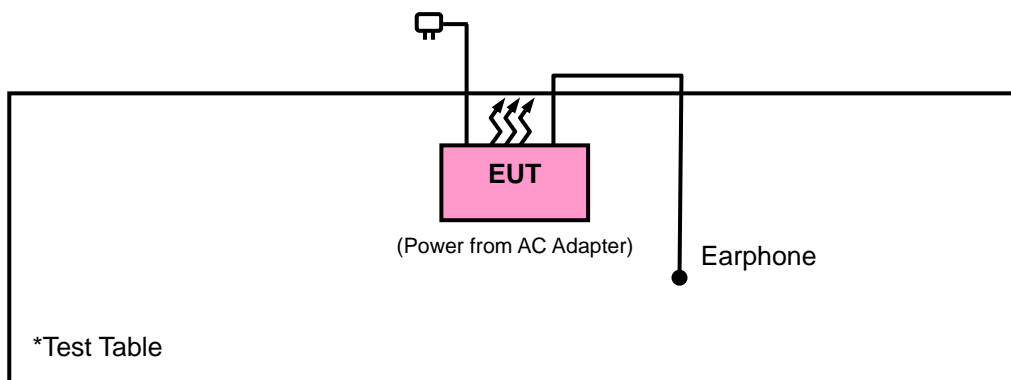

3.5 General Description of Applied Standards

The EUT is a RF Product. According to the specifications of the manufacturer, it must comply with the requirements of the following standards:

FCC Part 15, Subpart E (15.407)

789033 D02 General UNII Test Procedures New Rules v01

644545 D01 Guidance for IEEE 802 11ac v01r02

ANSI C63.10-2013

All test items have been performed and recorded as per the above standards.

NOTE: The EUT has been verified to comply with the requirements of FCC Part 15, Subpart B, Class B (DoC). The test report has been issued separately.

4 Test Types and Results

4.1 Radiated Emission and Bandedge Measurement

4.1.1 Limits of Radiated Emission and Bandedge Measurement

Radiated emissions which fall in the restricted bands must comply with the radiated emission limits specified as below table. Other emissions shall be at least 20dB below the highest level of the desired power:

Frequencies (MHz)	Field Strength (microvolts/meter)	Measurement Distance (meters)
0.009 ~ 0.490	2400/F(kHz)	300
0.490 ~ 1.705	24000/F(kHz)	30
1.705 ~ 30.0	30	30
30 ~ 88	100	3
88 ~ 216	150	3
216 ~ 960	200	3
Above 960	500	3

NOTE:

1. The lower limit shall apply at the transition frequencies.
2. Emission level (dBuV/m) = 20 log Emission level (uV/m).
3. For frequencies above 1000MHz, the field strength limits are based on average detector, however, the peak field strength of any emission shall not exceed the maximum permitted average limits, specified above by more than 20dB under any condition of modulation.

4.1.2 Limits of Unwanted Emission Out of The Restricted Bands

Applicable To	Limit	
789033 D02 General UNII Test Procedures New Rules v01	Field Strength AT 3m	
	PK:74 (dBµV/m)	AV:54 (dBµV/m)
Applicable To	EIRP Limit	Equivalent Field Strength At 3m
15.407(b)(1)	PK:-27 (dBm/MHz)	PK:68.2(dBµV/m)
15.407(b)(2)		
15.407(b)(3)		
15.407(b)(4)	PK:-27 (dBm/MHz) ^{*1} PK:-17 (dBm/MHz) ^{*2}	PK: 68.2(dBµV/m) ^{*1} PK:78.2 (dBµV/m) ^{*2}

NOTE: ^{*1} beyond 10MHz of the band edge ^{*2} within 10 MHz of band edge

The following formula is used to convert the equipment isotropic radiated power (eirp) to field strength:

$$E = \frac{1000000\sqrt{30P}}{3} \mu\text{V/m, where P is the eirp (Watts).}$$

4.1.3 Test Instruments

Description & Manufacturer	Model No.	Serial No.	Date of Calibration	Due Date of Calibration
Test Receiver Agilent	N9038A	MY51210203	Jan. 21, 2015	Jan. 21, 2016
Spectrum Analyzer Agilent	N9010A	MY52220314	Sep. 03, 2014	Sep. 02, 2015
Spectrum Analyzer ROHDE & SCHWARZ	FSU43	101261	Dec. 10, 2014	Dec. 09, 2015
BILOG Antenna SCHWARZBECK	VULB9168	9168-472	Feb. 04, 2015	Feb. 04, 2016
HORN Antenna SCHWARZBECK	BBHA 9120 D	9120D-969	Feb. 09, 2015	Feb. 09, 2016
HORN Antenna SCHWARZBECK	BBHA 9170	9170-480	Feb. 04, 2015	Feb. 04, 2016
Loop Antenna R&S	HFH2-Z2	100070	Mar. 06, 2014	Mar. 05, 2016
Preamplifier EMCI	EMC 012645	980115	Dec. 12, 2014	Dec. 11, 2015
Preamplifier EMCI	EMC 184045	980116	Jan. 09, 2015	Jan. 08, 2016
Preamplifier EMCI	EMC 330H	980112	Dec. 27, 2014	Dec. 26, 2015
Power Meter Anritsu	ML2495A	1232002	Sep. 17, 2014	Sep. 16, 2015
Power Sensor Anritsu	MA2411B	1207325	Sep. 17, 2014	Sep. 16, 2015
RF signal cable HUBER+SUHNNER	SUCOFLEX 104	309219/4 2950114	Oct. 18, 2014	Oct. 17, 2015
RF signal cable HUBER+SUHNNER	SUCOFLEX 104	250130/4	Oct. 18, 2014	Oct. 17, 2015
RF Coaxial Cable Worken	8D-FB	Cable-Ch10-01	Nov. 07, 2014	Nov. 06, 2015
Software BV ADT	E3 6.120103	NA	NA	NA
Antenna Tower MF	MFA-440H	NA	NA	NA
Turn Table MF	MFT-201SS	NA	NA	NA
Antenna Tower & Turn Table Controller MF	MF-7802	NA	NA	NA

- Note: 1. The calibration interval of the above test instruments is 12 months and the calibrations are traceable to NML/ROC and NIST/USA.
2. The calibration interval of the loop antenna is 24 months and the calibrations are traceable to NML/ROC and NIST/USA.
3. The test was performed in HwaYa Chamber 10.
4. The horn antenna and HP preamplifier (model: 8449B) are used only for the measurement of emission frequency above 1GHz if tested.
5. The FCC Site Registration No. is 690701.
6. The IC Site Registration No. is IC7450F-10.

4.1.4 Test Procedures

- a. The EUT was placed on the top of a rotating table 0.8 meters (for below 1GHz) / 1.5 meters (for above 1GHz) above the ground at 3 meter chamber room for test. The table was rotated 360 degrees to determine the position of the highest radiation.
- b. The EUT was set 3 meters away from the interference-receiving antenna, which was mounted on the top of a variable-height antenna tower.
- c. The height of antenna is varied from one meter to four meters above the ground to determine the maximum value of the field strength. Both horizontal and vertical polarizations of the antenna are set to make the measurement.
- d. For each suspected emission, the EUT was arranged to its worst case and then the antenna was tuned to heights from 1 meter to 4 meters and the rotatable table was turned from 0 degrees to 360 degrees to find the maximum reading.
- e. The test-receiver system was set to quasi-peak detect function and specified bandwidth with maximum hold mode when the test frequency is below 1 GHz.
- f. The test-receiver system was set to peak and average detect function and specified bandwidth with maximum hold mode when the test frequency is above 1 GHz. If the peak reading value also meets average limit, measurement with the average detector is unnecessary.

Note:

1. The resolution bandwidth and video bandwidth of test receiver/spectrum analyzer is 120kHz for Quasi-peak detection (QP) at frequency below 1GHz.
2. The resolution bandwidth of test receiver/spectrum analyzer is 1 MHz and the video bandwidth is 3 MHz for Peak detection (PK) at frequency above 1GHz.
3. The resolution bandwidth of test receiver/spectrum analyzer is 1MHz and the video bandwidth is 3MHz for RMS Average (Duty cycle < 98%) for Average detection (AV) at frequency above 1GHz, then the measurement results was added to a correction factor ($10 \log(1/\text{duty cycle})$).
4. The resolution bandwidth of test receiver/spectrum analyzer is 1MHz and the video bandwidth is 10Hz (Duty cycle $\geq 98\%$) for Average detection (AV) at frequency above 1GHz.
5. All modes of operation were investigated and the worst-case emissions are reported.

4.1.5 Deviation from Test Standard

No deviation.

4.1.6 Test Set Up

<Frequency Range below 1GHz>

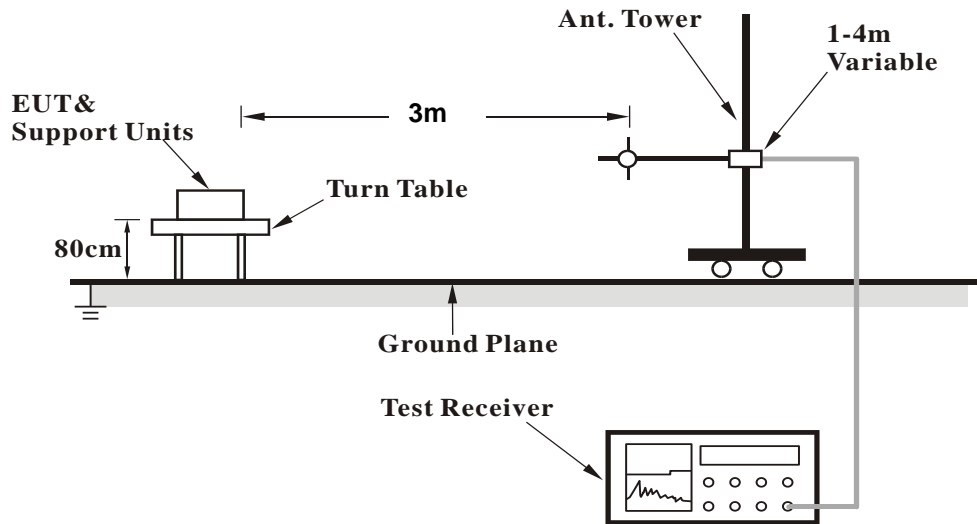

<Frequency Range above 1GHz>

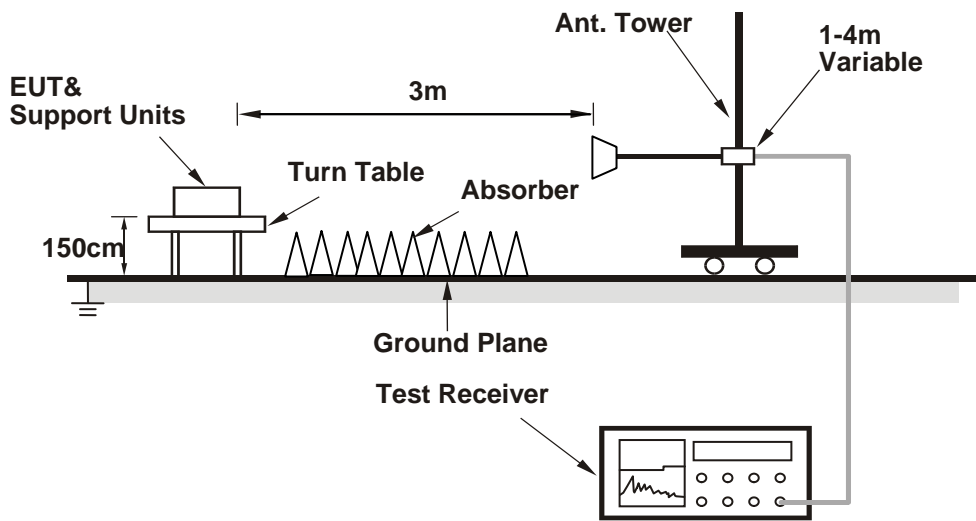

For the actual test configuration, please refer to the attached file (Test Setup Photo).

4.1.7 EUT Operating Conditions

- Placed the EUT on a testing table.
- Use the software to control the EUT under transmission condition continuously at specific channel frequency.

4.1.8 Test Results

Mode A

ABOVE 1GHz DATA :

802.11a

EUT TEST CONDITION		MEASUREMENT DETAIL	
CHANNEL	Channel 36	FREQUENCY RANGE	1GHz ~ 40GHz
INPUT POWER	120Vac, 60 Hz	DETECTOR FUNCTION	Peak (PK) Average (AV)
ENVIRONMENTAL CONDITIONS	25deg. C, 65%RH	TESTED BY	Anson Lin

ANTENNA POLARITY & TEST DISTANCE: HORIZONTAL AT 3 M										
FREQ. (MHz)	EMISSION LEVEL (dBuV/m)	READ LEVEL (dBuV)	LIMIT (dBuV/m)	MARGIN (dB)	ANTENNA FACTOR (dB/m)	CABLE LOSS (dB)	PREAMP FACTOR (dB)	ANTENNA HEIGHT (cm)	TABLE ANGLE (Degree)	REMARK
5150	49.72	49.52	54	-4.28	31.32	6.2	37.32	193	16	Average
5150	68.67	68.47	74	-5.33	31.32	6.2	37.32	193	16	Peak
5180	96.59	96.36			31.35	6.22	37.34	193	16	Average
5180	106.28	106.05			31.35	6.22	37.34	193	16	Peak
5352	38.28	37.69	54	-15.72	31.48	6.29	37.18	193	16	Average
5352	60.1	59.51	74	-13.9	31.48	6.29	37.18	193	16	Peak

ANTENNA POLARITY & TEST DISTANCE: VERTICAL AT 3 M										
FREQ. (MHz)	EMISSION LEVEL (dBuV/m)	READ LEVEL (dBuV)	LIMIT (dBuV/m)	MARGIN (dB)	ANTENNA FACTOR (dB/m)	CABLE LOSS (dB)	PREAMP FACTOR (dB)	ANTENNA HEIGHT (cm)	TABLE ANGLE (Degree)	REMARK
5142	46.62	46.4	54	-7.38	31.32	6.2	37.3	100	206	Average
5142	63.38	63.16	74	-10.62	31.32	6.2	37.3	100	206	Peak
5180	93.65	93.42			31.35	6.22	37.34	100	206	Average
5180	103.35	103.12			31.35	6.22	37.34	100	206	Peak
5400	38.23	37.57	54	-15.77	31.52	6.32	37.18	100	206	Average
5400	60.39	59.73	74	-13.61	31.52	6.32	37.18	100	206	Peak

REMARKS:

- Emission Level = Read Level + Antenna Factor + Cable Loss - Preamp Factor
Margin value = Emission level – Limit value
- 5180MHz: Fundamental frequency.



A D T

EUT TEST CONDITION		MEASUREMENT DETAIL	
CHANNEL	Channel 44	FREQUENCY RANGE	1GHz ~ 40GHz
INPUT POWER	120Vac, 60 Hz	DETECTOR FUNCTION	Peak (PK) Average (AV)
ENVIRONMENTAL CONDITIONS	25deg. C, 65%RH	TESTED BY	Anson Lin

ANTENNA POLARITY & TEST DISTANCE: HORIZONTAL AT 3 M										
FREQ. (MHz)	EMISSION LEVEL (dBuV/m)	READ LEVEL (dBuV)	LIMIT (dBuV/m)	MARGIN (dB)	ANTENNA FACTOR (dB/m)	CABLE LOSS (dB)	PREAMP FACTOR (dB)	ANTENNA HEIGHT (cm)	TABLE ANGLE (Degree)	REMARK
5022	39.82	39.68	54	-14.18	31.23	6.15	37.24	141	16	Average
5022	60.52	60.38	74	-13.48	31.23	6.15	37.24	141	16	Peak
5220	97.08	96.83			31.37	6.24	37.36	141	16	Average
5220	106.62	106.37			31.37	6.24	37.36	141	16	Peak
5408	38.25	37.59	54	-15.75	31.52	6.32	37.18	141	16	Average
5408	60.52	59.86	74	-13.48	31.52	6.32	37.18	141	16	Peak
ANTENNA POLARITY & TEST DISTANCE: VERTICAL AT 3 M										
FREQ. (MHz)	EMISSION LEVEL (dBuV/m)	READ LEVEL (dBuV)	LIMIT (dBuV/m)	MARGIN (dB)	ANTENNA FACTOR (dB/m)	CABLE LOSS (dB)	PREAMP FACTOR (dB)	ANTENNA HEIGHT (cm)	TABLE ANGLE (Degree)	REMARK
5084	38.27	38.1	54	-15.73	31.27	6.17	37.27	100	210	Average
5084	59.57	59.4	74	-14.43	31.27	6.17	37.27	100	210	Peak
5220	94.21	93.96			31.37	6.24	37.36	100	210	Average
5220	103.5	103.25			31.37	6.24	37.36	100	210	Peak
5406	38.25	37.59	54	-15.75	31.52	6.32	37.18	100	210	Average
5406	60.79	60.13	74	-13.21	31.52	6.32	37.18	100	210	Peak

REMARKS:

- Emission Level = Read Level + Antenna Factor + Cable Loss - Preamp Factor
Margin value = Emission level – Limit value
- 5220MHz: Fundamental frequency.

EUT TEST CONDITION		MEASUREMENT DETAIL	
CHANNEL	Channel 48	FREQUENCY RANGE	1GHz ~ 40GHz
INPUT POWER	120Vac, 60 Hz	DETECTOR FUNCTION	Peak (PK) Average (AV)
ENVIRONMENTAL CONDITIONS	25deg. C, 65%RH	TESTED BY	Anson Lin

ANTENNA POLARITY & TEST DISTANCE: HORIZONTAL AT 3 M										
FREQ. (MHz)	EMISSION LEVEL (dBuV/m)	READ LEVEL (dBuV)	LIMIT (dBuV/m)	MARGIN (dB)	ANTENNA FACTOR (dB/m)	CABLE LOSS (dB)	PREAMP FACTOR (dB)	ANTENNA HEIGHT (cm)	TABLE ANGLE (Degree)	REMARK
5142	40.28	40.06	54	-13.72	31.32	6.2	37.3	140	16	Average
5142	60.19	59.97	74	-13.81	31.32	6.2	37.3	140	16	Peak
5240	97.07	96.75			31.39	6.25	37.32	140	16	Average
5240	106.5	106.18			31.39	6.25	37.32	140	16	Peak
5368	38.42	37.8	54	-15.58	31.49	6.31	37.18	140	16	Average
5368	60.28	59.66	74	-13.72	31.49	6.31	37.18	140	16	Peak
ANTENNA POLARITY & TEST DISTANCE: VERTICAL AT 3 M										
FREQ. (MHz)	EMISSION LEVEL (dBuV/m)	READ LEVEL (dBuV)	LIMIT (dBuV/m)	MARGIN (dB)	ANTENNA FACTOR (dB/m)	CABLE LOSS (dB)	PREAMP FACTOR (dB)	ANTENNA HEIGHT (cm)	TABLE ANGLE (Degree)	REMARK
5132	38.84	38.63	54	-15.16	31.31	6.2	37.3	100	206	Average
5132	60.02	59.81	74	-13.98	31.31	6.2	37.3	100	206	Peak
5240	94.27	93.95			31.39	6.25	37.32	100	206	Average
5240	103.78	103.46			31.39	6.25	37.32	100	206	Peak
5386	38.09	37.45	54	-15.91	31.51	6.31	37.18	100	206	Average
5386	61.52	60.88	74	-12.48	31.51	6.31	37.18	100	206	Peak

REMARKS:

- Emission Level = Read Level + Antenna Factor + Cable Loss - Preamp Factor
Margin value = Emission level – Limit value
- 5240MHz: Fundamental frequency.



A D T

EUT TEST CONDITION		MEASUREMENT DETAIL	
CHANNEL	Channel 52	FREQUENCY RANGE	1GHz ~ 40GHz
INPUT POWER	120Vac, 60 Hz	DETECTOR FUNCTION	Peak (PK) Average (AV)
ENVIRONMENTAL CONDITIONS	25deg. C, 65%RH	TESTED BY	Anson Lin

ANTENNA POLARITY & TEST DISTANCE: HORIZONTAL AT 3 M										
FREQ. (MHz)	EMISSION LEVEL (dBuV/m)	READ LEVEL (dBuV)	LIMIT (dBuV/m)	MARGIN (dB)	ANTENNA FACTOR (dB/m)	CABLE LOSS (dB)	PREAMP FACTOR (dB)	ANTENNA HEIGHT (cm)	TABLE ANGLE (Degree)	REMARK
5038	39.08	38.93	54	-14.92	31.24	6.15	37.24	168	14	Average
5038	59.37	59.22	74	-14.63	31.24	6.15	37.24	168	14	Peak
5260	95.23	94.84			31.41	6.25	37.27	168	14	Average
5260	104.31	103.92			31.41	6.25	37.27	168	14	Peak
5378	38.44	37.8	54	-15.56	31.51	6.31	37.18	168	14	Average
5378	60.74	60.1	74	-13.26	31.51	6.31	37.18	168	14	Peak

ANTENNA POLARITY & TEST DISTANCE: VERTICAL AT 3 M										
FREQ. (MHz)	EMISSION LEVEL (dBuV/m)	READ LEVEL (dBuV)	LIMIT (dBuV/m)	MARGIN (dB)	ANTENNA FACTOR (dB/m)	CABLE LOSS (dB)	PREAMP FACTOR (dB)	ANTENNA HEIGHT (cm)	TABLE ANGLE (Degree)	REMARK
5054	37.89	37.73	54	-16.11	31.24	6.17	37.25	100	346	Average
5054	60.32	60.16	74	-13.68	31.24	6.17	37.25	100	346	Peak
5260	93.42	93.03			31.41	6.25	37.27	100	346	Average
5260	103.02	102.63			31.41	6.25	37.27	100	346	Peak
5374	38.55	37.93	54	-15.45	31.49	6.31	37.18	100	346	Average
5374	59.75	59.13	74	-14.25	31.49	6.31	37.18	100	346	Peak

REMARKS:

- Emission Level = Read Level + Antenna Factor + Cable Loss - Preamp Factor
Margin value = Emission level – Limit value
- 5260MHz: Fundamental frequency.



A D T

EUT TEST CONDITION		MEASUREMENT DETAIL	
CHANNEL	Channel 60	FREQUENCY RANGE	1GHz ~ 40GHz
INPUT POWER	120Vac, 60 Hz	DETECTOR FUNCTION	Peak (PK) Average (AV)
ENVIRONMENTAL CONDITIONS	25deg. C, 65%RH	TESTED BY	Anson Lin

ANTENNA POLARITY & TEST DISTANCE: HORIZONTAL AT 3 M										
FREQ. (MHz)	EMISSION LEVEL (dBuV/m)	READ LEVEL (dBuV)	LIMIT (dBuV/m)	MARGIN (dB)	ANTENNA FACTOR (dB/m)	CABLE LOSS (dB)	PREAMP FACTOR (dB)	ANTENNA HEIGHT (cm)	TABLE ANGLE (Degree)	REMARK
5112	39.05	38.85	54	-14.95	31.29	6.19	37.28	173	7	Average
5112	59.74	59.54	74	-14.26	31.29	6.19	37.28	173	7	Peak
5300	95.82	95.3			31.44	6.27	37.19	173	7	Average
5300	104.87	104.35			31.44	6.27	37.19	173	7	Peak
5362	39.16	38.54	54	-14.84	31.49	6.31	37.18	173	7	Average
5362	60.05	59.43	74	-13.95	31.49	6.31	37.18	173	7	Peak
ANTENNA POLARITY & TEST DISTANCE: VERTICAL AT 3 M										
FREQ. (MHz)	EMISSION LEVEL (dBuV/m)	READ LEVEL (dBuV)	LIMIT (dBuV/m)	MARGIN (dB)	ANTENNA FACTOR (dB/m)	CABLE LOSS (dB)	PREAMP FACTOR (dB)	ANTENNA HEIGHT (cm)	TABLE ANGLE (Degree)	REMARK
5076	37.97	37.8	54	-16.03	31.27	6.17	37.27	108	342	Average
5076	60.15	59.98	74	-13.85	31.27	6.17	37.27	108	342	Peak
5300	94.28	93.76			31.44	6.27	37.19	108	342	Average
5300	103.73	103.21			31.44	6.27	37.19	108	342	Peak
5418	38.54	37.87	54	-15.46	31.53	6.32	37.18	108	342	Average
5418	59.64	58.97	74	-14.36	31.53	6.32	37.18	108	342	Peak

REMARKS:

- Emission Level = Read Level + Antenna Factor + Cable Loss - Preamp Factor
Margin value = Emission level – Limit value
- 5300MHz: Fundamental frequency.

EUT TEST CONDITION		MEASUREMENT DETAIL	
CHANNEL	Channel 64	FREQUENCY RANGE	1GHz ~ 40GHz
INPUT POWER	120Vac, 60 Hz	DETECTOR FUNCTION	Peak (PK) Average (AV)
ENVIRONMENTAL CONDITIONS	25deg. C, 65%RH	TESTED BY	Anson Lin

ANTENNA POLARITY & TEST DISTANCE: HORIZONTAL AT 3 M										
FREQ. (MHz)	EMISSION LEVEL (dBuV/m)	READ LEVEL (dBuV)	LIMIT (dBuV/m)	MARGIN (dB)	ANTENNA FACTOR (dB/m)	CABLE LOSS (dB)	PREAMP FACTOR (dB)	ANTENNA HEIGHT (cm)	TABLE ANGLE (Degree)	REMARK
5142	38.16	37.94	54	-15.84	31.32	6.2	37.3	195	8	Average
5142	60.6	60.38	74	-13.4	31.32	6.2	37.3	195	8	Peak
5320	95.25	94.7			31.45	6.29	37.19	195	8	Average
5320	104.63	104.08			31.45	6.29	37.19	195	8	Peak
5348	43.35	42.76	54	-10.65	31.48	6.29	37.18	195	8	Average
5348	64.6	64.01	74	-9.4	31.48	6.29	37.18	195	8	Peak
ANTENNA POLARITY & TEST DISTANCE: VERTICAL AT 3 M										
FREQ. (MHz)	EMISSION LEVEL (dBuV/m)	READ LEVEL (dBuV)	LIMIT (dBuV/m)	MARGIN (dB)	ANTENNA FACTOR (dB/m)	CABLE LOSS (dB)	PREAMP FACTOR (dB)	ANTENNA HEIGHT (cm)	TABLE ANGLE (Degree)	REMARK
5090	37.82	37.62	54	-16.18	31.28	6.19	37.27	108	341	Average
5090	60.76	60.56	74	-13.24	31.28	6.19	37.27	108	341	Peak
5320	94.26	93.71			31.45	6.29	37.19	108	341	Average
5320	103.72	103.17			31.45	6.29	37.19	108	341	Peak
5350	42.54	41.95	54	-11.46	31.48	6.29	37.18	108	341	Average
5350	62.45	61.86	74	-11.55	31.48	6.29	37.18	108	341	Peak

REMARKS:

- Emission Level = Read Level + Antenna Factor + Cable Loss - Preamp Factor
Margin value = Emission level – Limit value
- 5320MHz: Fundamental frequency.

EUT TEST CONDITION		MEASUREMENT DETAIL	
CHANNEL	Channel 100	FREQUENCY RANGE	1GHz ~ 40GHz
INPUT POWER	120Vac, 60 Hz	DETECTOR FUNCTION	Peak (PK) Average (AV)
ENVIRONMENTAL CONDITIONS	25deg. C, 65%RH	TESTED BY	Anson Lin

ANTENNA POLARITY & TEST DISTANCE: HORIZONTAL AT 3 M										
FREQ. (MHz)	EMISSION LEVEL (dBuV/m)	READ LEVEL (dBuV)	LIMIT (dBuV/m)	MARGIN (dB)	ANTENNA FACTOR (dB/m)	CABLE LOSS (dB)	PREAMP FACTOR (dB)	ANTENNA HEIGHT (cm)	TABLE ANGLE (Degree)	REMARK
5392	42.33	41.69	54	-11.67	31.51	6.31	37.18	121	148	Average
5392	60.69	60.05	74	-13.31	31.51	6.31	37.18	121	148	Peak
5470	61.57	60.74	68.2	-6.63	31.57	6.34	37.08	121	148	Peak
5500	91.07	90.14			31.6	6.36	37.03	121	148	Average
5500	100.53	99.6			31.6	6.36	37.03	121	148	Peak
5725	60.2	58.92	68.2	-8	31.96	6.75	37.43	121	148	Peak
ANTENNA POLARITY & TEST DISTANCE: VERTICAL AT 3 M										
FREQ. (MHz)	EMISSION LEVEL (dBuV/m)	READ LEVEL (dBuV)	LIMIT (dBuV/m)	MARGIN (dB)	ANTENNA FACTOR (dB/m)	CABLE LOSS (dB)	PREAMP FACTOR (dB)	ANTENNA HEIGHT (cm)	TABLE ANGLE (Degree)	REMARK
5458	48.48	47.66	54	-5.52	31.56	6.34	37.08	198	350	Average
5458	62.91	62.09	74	-11.09	31.56	6.34	37.08	198	350	Peak
5470	65.62	64.79	68.2	-2.58	31.57	6.34	37.08	198	350	Peak
5500	97.98	97.05			31.6	6.36	37.03	198	350	Average
5500	107.71	106.78			31.6	6.36	37.03	198	350	Peak
5725	59.96	58.68	68.2	-8.24	31.96	6.75	37.43	198	350	Peak

REMARKS:

- Emission Level = Read Level + Antenna Factor + Cable Loss - Preamp Factor
Margin value = Emission level – Limit value
- 5500MHz: Fundamental frequency.
- 5470MHz & 5725MHz: Out of restricted band

EUT TEST CONDITION		MEASUREMENT DETAIL	
CHANNEL	Channel 116	FREQUENCY RANGE	1GHz ~ 40GHz
INPUT POWER	120Vac, 60 Hz	DETECTOR FUNCTION	Peak (PK) Average (AV)
ENVIRONMENTAL CONDITIONS	25deg. C, 65%RH	TESTED BY	Anson Lin

ANTENNA POLARITY & TEST DISTANCE: HORIZONTAL AT 3 M										
FREQ. (MHz)	EMISSION LEVEL (dBuV/m)	READ LEVEL (dBuV)	LIMIT (dBuV/m)	MARGIN (dB)	ANTENNA FACTOR (dB/m)	CABLE LOSS (dB)	PREAMP FACTOR (dB)	ANTENNA HEIGHT (cm)	TABLE ANGLE (Degree)	REMARK
5370	38.15	37.53	54	-15.85	31.49	6.31	37.18	115	148	Average
5370	60.48	59.86	74	-13.52	31.49	6.31	37.18	115	148	Peak
5470	59.85	59.02	68.2	-8.35	31.57	6.34	37.08	115	148	Peak
5580	89.83	88.79			31.71	6.49	37.16	115	148	Average
5580	100.42	99.38			31.71	6.49	37.16	115	148	Peak
5725	60.1	58.82	68.2	-8.1	31.96	6.75	37.43	115	148	Peak
ANTENNA POLARITY & TEST DISTANCE: VERTICAL AT 3 M										
FREQ. (MHz)	EMISSION LEVEL (dBuV/m)	READ LEVEL (dBuV)	LIMIT (dBuV/m)	MARGIN (dB)	ANTENNA FACTOR (dB/m)	CABLE LOSS (dB)	PREAMP FACTOR (dB)	ANTENNA HEIGHT (cm)	TABLE ANGLE (Degree)	REMARK
5414	38.38	37.71	54	-15.62	31.53	6.32	37.18	203	351	Average
5414	61.69	61.02	74	-12.31	31.53	6.32	37.18	203	351	Peak
5470	61.11	60.28	68.2	-7.09	31.57	6.34	37.08	203	351	Peak
5580	97.16	96.12			31.71	6.49	37.16	203	351	Average
5580	107.05	106.01			31.71	6.49	37.16	203	351	Peak
5725	60.58	59.3	68.2	-7.62	31.96	6.75	37.43	203	351	Peak

REMARKS:

- Emission Level = Read Level + Antenna Factor + Cable Loss - Preamp Factor
Margin value = Emission level – Limit value
- 5580MHz: Fundamental frequency.
- 5470MHz & 5725MHz: Out of restricted band



EUT TEST CONDITION		MEASUREMENT DETAIL	
CHANNEL	Channel 140	FREQUENCY RANGE	1GHz ~ 40GHz
INPUT POWER	120Vac, 60 Hz	DETECTOR FUNCTION	Peak (PK) Average (AV)
ENVIRONMENTAL CONDITIONS	25deg. C, 65%RH	TESTED BY	Anson Lin

ANTENNA POLARITY & TEST DISTANCE: HORIZONTAL AT 3 M										
FREQ. (MHz)	EMISSION LEVEL (dBuV/m)	READ LEVEL (dBuV)	LIMIT (dBuV/m)	MARGIN (dB)	ANTENNA FACTOR (dB/m)	CABLE LOSS (dB)	PREAMP FACTOR (dB)	ANTENNA HEIGHT (cm)	TABLE ANGLE (Degree)	REMARK
5382	38.11	37.47	54	-15.89	31.51	6.31	37.18	103	75	Average
5382	60.11	59.47	74	-13.89	31.51	6.31	37.18	103	75	Peak
5470	60.17	59.34	68.2	-8.03	31.57	6.34	37.08	103	75	Peak
5700	90.67	89.48			31.9	6.69	37.4	103	75	Average
5700	100.09	98.9			31.9	6.69	37.4	103	75	Peak
5725	62.6	61.32	68.2	-5.6	31.96	6.75	37.43	103	75	Peak
ANTENNA POLARITY & TEST DISTANCE: VERTICAL AT 3 M										
FREQ. (MHz)	EMISSION LEVEL (dBuV/m)	READ LEVEL (dBuV)	LIMIT (dBuV/m)	MARGIN (dB)	ANTENNA FACTOR (dB/m)	CABLE LOSS (dB)	PREAMP FACTOR (dB)	ANTENNA HEIGHT (cm)	TABLE ANGLE (Degree)	REMARK
5420	38.43	37.76	54	-15.57	31.53	6.32	37.18	198	351	Average
5420	60.6	59.93	74	-13.4	31.53	6.32	37.18	198	351	Peak
5470	59.9	59.07	68.2	-8.3	31.57	6.34	37.08	198	351	Peak
5700	97.1	95.91			31.9	6.69	37.4	198	351	Average
5700	107.72	106.53			31.9	6.69	37.4	198	351	Peak
5725	66.1	64.82	68.2	-2.1	31.96	6.75	37.43	198	351	Peak

REMARKS:

- Emission Level = Read Level + Antenna Factor + Cable Loss - Preamp Factor
Margin value = Emission level – Limit value
- 5700MHz: Fundamental frequency.
- 5470MHz & 5725MHz: Out of restricted band

EUT TEST CONDITION		MEASUREMENT DETAIL	
CHANNEL	Channel 149	FREQUENCY RANGE	1GHz ~ 40GHz
INPUT POWER	120Vac, 60 Hz	DETECTOR FUNCTION	Peak (PK) Average (AV)
ENVIRONMENTAL CONDITIONS	25deg. C, 65%RH	TESTED BY	Anson Lin

ANTENNA POLARITY & TEST DISTANCE: HORIZONTAL AT 3 M										
FREQ. (MHz)	EMISSION LEVEL (dBuV/m)	READ LEVEL (dBuV)	LIMIT (dBuV/m)	MARGIN (dB)	ANTENNA FACTOR (dB/m)	CABLE LOSS (dB)	PREAMP FACTOR (dB)	ANTENNA HEIGHT (cm)	TABLE ANGLE (Degree)	REMARK
5714	64.04	62.85	68.2	-4.16	31.93	6.69	37.43	178	15	Peak
5725	75.18	73.9	78.2	-3.02	31.96	6.75	37.43	178	15	Peak
5745	99.62	98.35			31.99	6.75	37.47	178	15	Average
5745	108.95	107.68			31.99	6.75	37.47	178	15	Peak
5850	59.29	57.77	78.2	-18.91	32.15	6.88	37.51	178	15	Peak
5861	60.43	58.8	68.2	-7.77	32.18	6.95	37.5	178	15	Peak
ANTENNA POLARITY & TEST DISTANCE: VERTICAL AT 3 M										
FREQ. (MHz)	EMISSION LEVEL (dBuV/m)	READ LEVEL (dBuV)	LIMIT (dBuV/m)	MARGIN (dB)	ANTENNA FACTOR (dB/m)	CABLE LOSS (dB)	PREAMP FACTOR (dB)	ANTENNA HEIGHT (cm)	TABLE ANGLE (Degree)	REMARK
5714	63.26	62.07	68.2	-4.94	31.93	6.69	37.43	191	46	Peak
5725	72.05	70.77	78.2	-6.15	31.96	6.75	37.43	191	46	Peak
5745	97.35	96.08			31.99	6.75	37.47	191	46	Average
5745	106.42	105.15			31.99	6.75	37.47	191	46	Peak
5850	60.3	58.78	78.2	-17.9	32.15	6.88	37.51	191	46	Peak
5861	59.3	57.67	68.2	-8.9	32.18	6.95	37.5	191	46	Peak

REMARKS:

- Emission Level = Read Level + Antenna Factor + Cable Loss - Preamp Factor
Margin value = Emission level – Limit value
- 5745MHz: Fundamental frequency.
- 5714MHz & 5725MHz & 5850MHz & 5861MHz: Out of restricted band

EUT TEST CONDITION		MEASUREMENT DETAIL	
CHANNEL	Channel 157	FREQUENCY RANGE	1GHz ~ 40GHz
INPUT POWER	120Vac, 60 Hz	DETECTOR FUNCTION	Peak (PK) Average (AV)
ENVIRONMENTAL CONDITIONS	25deg. C, 65%RH	TESTED BY	Anson Lin

ANTENNA POLARITY & TEST DISTANCE: HORIZONTAL AT 3 M										
FREQ. (MHz)	EMISSION LEVEL (dBuV/m)	READ LEVEL (dBuV)	LIMIT (dBuV/m)	MARGIN (dB)	ANTENNA FACTOR (dB/m)	CABLE LOSS (dB)	PREAMP FACTOR (dB)	ANTENNA HEIGHT (cm)	TABLE ANGLE (Degree)	REMARK
5714	59.96	58.77	68.2	-8.24	31.93	6.69	37.43	177	13	Peak
5725	59.31	58.03	78.2	-18.89	31.96	6.75	37.43	177	13	Peak
5785	100.08	98.76			32.04	6.82	37.54	177	13	Average
5785	109.69	108.37			32.04	6.82	37.54	177	13	Peak
5850	60.7	59.18	78.2	-17.5	32.15	6.88	37.51	177	13	Peak
5861	60.23	58.6	68.2	-7.97	32.18	6.95	37.5	177	13	Peak
ANTENNA POLARITY & TEST DISTANCE: VERTICAL AT 3 M										
FREQ. (MHz)	EMISSION LEVEL (dBuV/m)	READ LEVEL (dBuV)	LIMIT (dBuV/m)	MARGIN (dB)	ANTENNA FACTOR (dB/m)	CABLE LOSS (dB)	PREAMP FACTOR (dB)	ANTENNA HEIGHT (cm)	TABLE ANGLE (Degree)	REMARK
5714	59.77	58.58	68.2	-8.43	31.93	6.69	37.43	188	56	Peak
5725	59.9	58.62	78.2	-18.3	31.96	6.75	37.43	188	56	Peak
5785	97.72	96.4			32.04	6.82	37.54	188	56	Average
5785	106.77	105.45			32.04	6.82	37.54	188	56	Peak
5850	61.46	59.94	78.2	-16.74	32.15	6.88	37.51	188	56	Peak
5861	59.6	57.97	68.2	-8.6	32.18	6.95	37.5	188	56	Peak

REMARKS:

- Emission Level = Read Level + Antenna Factor + Cable Loss - Preamp Factor
Margin value = Emission level – Limit value
- 5785MHz: Fundamental frequency.
- 5714MHz & 5725MHz & 5850MHz & 5861MHz: Out of restricted band

EUT TEST CONDITION		MEASUREMENT DETAIL	
CHANNEL	Channel 165	FREQUENCY RANGE	1GHz ~ 40GHz
INPUT POWER	120Vac, 60 Hz	DETECTOR FUNCTION	Peak (PK) Average (AV)
ENVIRONMENTAL CONDITIONS	25deg. C, 65%RH	TESTED BY	Anson Lin

ANTENNA POLARITY & TEST DISTANCE: HORIZONTAL AT 3 M										
FREQ. (MHz)	EMISSION LEVEL (dBuV/m)	READ LEVEL (dBuV)	LIMIT (dBuV/m)	MARGIN (dB)	ANTENNA FACTOR (dB/m)	CABLE LOSS (dB)	PREAMP FACTOR (dB)	ANTENNA HEIGHT (cm)	TABLE ANGLE (Degree)	REMARK
5714	59.69	58.5	68.2	-8.51	31.93	6.69	37.43	174	4	Peak
5725	59.78	58.5	78.2	-18.42	31.96	6.75	37.43	174	4	Peak
5825	99.74	98.27			32.12	6.88	37.53	174	4	Average
5825	108.94	107.47			32.12	6.88	37.53	174	4	Peak
5850	69.31	67.79	78.2	-8.89	32.15	6.88	37.51	174	4	Peak
5861	63.48	61.85	68.2	-4.72	32.18	6.95	37.5	174	4	Peak
ANTENNA POLARITY & TEST DISTANCE: VERTICAL AT 3 M										
FREQ. (MHz)	EMISSION LEVEL (dBuV/m)	READ LEVEL (dBuV)	LIMIT (dBuV/m)	MARGIN (dB)	ANTENNA FACTOR (dB/m)	CABLE LOSS (dB)	PREAMP FACTOR (dB)	ANTENNA HEIGHT (cm)	TABLE ANGLE (Degree)	REMARK
5714	60.4	59.21	68.2	-7.8	31.93	6.69	37.43	204	37	Peak
5725	59.22	57.94	78.2	-18.98	31.96	6.75	37.43	204	37	Peak
5825	97.48	96.01			32.12	6.88	37.53	204	37	Average
5825	106.54	105.07			32.12	6.88	37.53	204	37	Peak
5850	65.9	64.38	78.2	-12.3	32.15	6.88	37.51	204	37	Peak
5861	61.39	59.76	68.2	-6.81	32.18	6.95	37.5	204	37	Peak

REMARKS:

- Emission Level = Read Level + Antenna Factor + Cable Loss - Preamp Factor
Margin value = Emission level – Limit value
- 5825MHz: Fundamental frequency.
- 5714MHz & 5725MHz & 5850MHz & 5861MHz: Out of restricted band

802.11n (20MHz)

EUT TEST CONDITION		MEASUREMENT DETAIL	
CHANNEL	Channel 36	FREQUENCY RANGE	1GHz ~ 40GHz
INPUT POWER	120Vac, 60 Hz	DETECTOR FUNCTION	Peak (PK) Average (AV)
ENVIRONMENTAL CONDITIONS	25deg. C, 65%RH	TESTED BY	Anson Lin

ANTENNA POLARITY & TEST DISTANCE: HORIZONTAL AT 3 M

FREQ. (MHz)	EMISSION LEVEL (dBuV/m)	READ LEVEL (dBuV)	LIMIT (dBuV/m)	MARGIN (dB)	ANTENNA FACTOR (dB/m)	CABLE LOSS (dB)	PREAMP FACTOR (dB)	ANTENNA HEIGHT (cm)	TABLE ANGLE (Degree)	REMARK
5148	51.64	51.44	54	-2.36	31.32	6.2	37.32	128	16	Average
5148	68.08	67.88	74	-5.92	31.32	6.2	37.32	128	16	Peak
5180	97.41	97.18			31.35	6.22	37.34	128	16	Average
5180	106.7	106.47			31.35	6.22	37.34	128	16	Peak
5438	38.51	37.75	54	-15.49	31.55	6.34	37.13	128	16	Average
5438	59.76	59	74	-14.24	31.55	6.34	37.13	128	16	Peak

ANTENNA POLARITY & TEST DISTANCE: VERTICAL AT 3 M

FREQ. (MHz)	EMISSION LEVEL (dBuV/m)	READ LEVEL (dBuV)	LIMIT (dBuV/m)	MARGIN (dB)	ANTENNA FACTOR (dB/m)	CABLE LOSS (dB)	PREAMP FACTOR (dB)	ANTENNA HEIGHT (cm)	TABLE ANGLE (Degree)	REMARK
5148	48.27	48.07	54	-5.73	31.32	6.2	37.32	100	204	Average
5148	64.83	64.63	74	-9.17	31.32	6.2	37.32	100	204	Peak
5180	93.92	93.69			31.35	6.22	37.34	100	204	Average
5180	103.69	103.46			31.35	6.22	37.34	100	204	Peak
5458	38.25	37.43	54	-15.75	31.56	6.34	37.08	100	204	Average
5458	60.65	59.83	74	-13.35	31.56	6.34	37.08	100	204	Peak

REMARKS:

- Emission Level = Read Level + Antenna Factor + Cable Loss - Preamp Factor
Margin value = Emission level – Limit value
- 5180MHz: Fundamental frequency.



EUT TEST CONDITION		MEASUREMENT DETAIL	
CHANNEL	Channel 44	FREQUENCY RANGE	1GHz ~ 40GHz
INPUT POWER	120Vac, 60 Hz	DETECTOR FUNCTION	Peak (PK) Average (AV)
ENVIRONMENTAL CONDITIONS	25deg. C, 65%RH	TESTED BY	Anson Lin

ANTENNA POLARITY & TEST DISTANCE: HORIZONTAL AT 3 M										
FREQ. (MHz)	EMISSION LEVEL (dBuV/m)	READ LEVEL (dBuV)	LIMIT (dBuV/m)	MARGIN (dB)	ANTENNA FACTOR (dB/m)	CABLE LOSS (dB)	PREAMP FACTOR (dB)	ANTENNA HEIGHT (cm)	TABLE ANGLE (Degree)	REMARK
5092	39.74	39.54	54	-14.26	31.28	6.19	37.27	171	15	Average
5092	60.77	60.57	74	-13.23	31.28	6.19	37.27	171	15	Peak
5220	97.22	96.97			31.37	6.24	37.36	171	15	Average
5220	106.65	106.4			31.37	6.24	37.36	171	15	Peak
5376	38.14	37.52	54	-15.86	31.49	6.31	37.18	171	15	Average
5376	60.77	60.15	74	-13.23	31.49	6.31	37.18	171	15	Peak

ANTENNA POLARITY & TEST DISTANCE: VERTICAL AT 3 M										
FREQ. (MHz)	EMISSION LEVEL (dBuV/m)	READ LEVEL (dBuV)	LIMIT (dBuV/m)	MARGIN (dB)	ANTENNA FACTOR (dB/m)	CABLE LOSS (dB)	PREAMP FACTOR (dB)	ANTENNA HEIGHT (cm)	TABLE ANGLE (Degree)	REMARK
5014	38.23	38.1	54	-15.77	31.21	6.15	37.23	119	143	Average
5014	60.04	59.91	74	-13.96	31.21	6.15	37.23	119	143	Peak
5220	94.51	94.26			31.37	6.24	37.36	119	143	Average
5220	103.37	103.12			31.37	6.24	37.36	119	143	Peak
5368	38.14	37.52	54	-15.86	31.49	6.31	37.18	119	143	Average
5368	62.3	61.68	74	-11.7	31.49	6.31	37.18	119	143	Peak

REMARKS:

- Emission Level = Read Level + Antenna Factor + Cable Loss - Preamp Factor
Margin value = Emission level – Limit value
- 5220MHz: Fundamental frequency.

EUT TEST CONDITION		MEASUREMENT DETAIL	
CHANNEL	Channel 48	FREQUENCY RANGE	1GHz ~ 40GHz
INPUT POWER	120Vac, 60 Hz	DETECTOR FUNCTION	Peak (PK) Average (AV)
ENVIRONMENTAL CONDITIONS	25deg. C, 65%RH	TESTED BY	Anson Lin

ANTENNA POLARITY & TEST DISTANCE: HORIZONTAL AT 3 M										
FREQ. (MHz)	EMISSION LEVEL (dBuV/m)	READ LEVEL (dBuV)	LIMIT (dBuV/m)	MARGIN (dB)	ANTENNA FACTOR (dB/m)	CABLE LOSS (dB)	PREAMP FACTOR (dB)	ANTENNA HEIGHT (cm)	TABLE ANGLE (Degree)	REMARK
5102	40.16	39.97	54	-13.84	31.28	6.19	37.28	182	16	Average
5102	59.89	59.7	74	-14.11	31.28	6.19	37.28	182	16	Peak
5240	96.92	96.6			31.39	6.25	37.32	182	16	Average
5240	106.29	105.97			31.39	6.25	37.32	182	16	Peak
5406	38.26	37.6	54	-15.74	31.52	6.32	37.18	182	16	Average
5406	60.32	59.66	74	-13.68	31.52	6.32	37.18	182	16	Peak
ANTENNA POLARITY & TEST DISTANCE: VERTICAL AT 3 M										
FREQ. (MHz)	EMISSION LEVEL (dBuV/m)	READ LEVEL (dBuV)	LIMIT (dBuV/m)	MARGIN (dB)	ANTENNA FACTOR (dB/m)	CABLE LOSS (dB)	PREAMP FACTOR (dB)	ANTENNA HEIGHT (cm)	TABLE ANGLE (Degree)	REMARK
5132	38.44	38.23	54	-15.56	31.31	6.2	37.3	113	148	Average
5132	61.05	60.84	74	-12.95	31.31	6.2	37.3	113	148	Peak
5240	93.71	93.39			31.39	6.25	37.32	113	148	Average
5240	103.39	103.07			31.39	6.25	37.32	113	148	Peak
5348	38.13	37.54	54	-15.87	31.48	6.29	37.18	113	148	Average
5348	61.76	61.17	74	-12.24	31.48	6.29	37.18	113	148	Peak

REMARKS:

- Emission Level = Read Level + Antenna Factor + Cable Loss - Preamp Factor
Margin value = Emission level – Limit value
- 5240MHz: Fundamental frequency.



EUT TEST CONDITION		MEASUREMENT DETAIL	
CHANNEL	Channel 52	FREQUENCY RANGE	1GHz ~ 40GHz
INPUT POWER	120Vac, 60 Hz	DETECTOR FUNCTION	Peak (PK) Average (AV)
ENVIRONMENTAL CONDITIONS	25deg. C, 65%RH	TESTED BY	Anson Lin

ANTENNA POLARITY & TEST DISTANCE: HORIZONTAL AT 3 M										
FREQ. (MHz)	EMISSION LEVEL (dBuV/m)	READ LEVEL (dBuV)	LIMIT (dBuV/m)	MARGIN (dB)	ANTENNA FACTOR (dB/m)	CABLE LOSS (dB)	PREAMP FACTOR (dB)	ANTENNA HEIGHT (cm)	TABLE ANGLE (Degree)	REMARK
5150	39.26	39.06	54	-14.74	31.32	6.2	37.32	156	8	Average
5150	60.04	59.84	74	-13.96	31.32	6.2	37.32	156	8	Peak
5260	96.64	96.25			31.41	6.25	37.27	156	8	Average
5260	105.78	105.39			31.41	6.25	37.27	156	8	Peak
5418	38.76	38.09	54	-15.24	31.53	6.32	37.18	156	8	Average
5418	60.46	59.79	74	-13.54	31.53	6.32	37.18	156	8	Peak
ANTENNA POLARITY & TEST DISTANCE: VERTICAL AT 3 M										
FREQ. (MHz)	EMISSION LEVEL (dBuV/m)	READ LEVEL (dBuV)	LIMIT (dBuV/m)	MARGIN (dB)	ANTENNA FACTOR (dB/m)	CABLE LOSS (dB)	PREAMP FACTOR (dB)	ANTENNA HEIGHT (cm)	TABLE ANGLE (Degree)	REMARK
5046	37.96	37.82	54	-16.04	31.24	6.15	37.25	102	341	Average
5046	59.22	59.08	74	-14.78	31.24	6.15	37.25	102	341	Peak
5260	94.08	93.69			31.41	6.25	37.27	102	341	Average
5260	103.14	102.75			31.41	6.25	37.27	102	341	Peak
5456	38.58	37.76	54	-15.42	31.56	6.34	37.08	102	341	Average
5456	59.9	59.08	74	-14.1	31.56	6.34	37.08	102	341	Peak

REMARKS:

- Emission Level = Read Level + Antenna Factor + Cable Loss - Preamp Factor
Margin value = Emission level – Limit value
- 5260MHz: Fundamental frequency.

EUT TEST CONDITION		MEASUREMENT DETAIL	
CHANNEL	Channel 60	FREQUENCY RANGE	1GHz ~ 40GHz
INPUT POWER	120Vac, 60 Hz	DETECTOR FUNCTION	Peak (PK) Average (AV)
ENVIRONMENTAL CONDITIONS	25deg. C, 65%RH	TESTED BY	Anson Lin

ANTENNA POLARITY & TEST DISTANCE: HORIZONTAL AT 3 M										
FREQ. (MHz)	EMISSION LEVEL (dBuV/m)	READ LEVEL (dBuV)	LIMIT (dBuV/m)	MARGIN (dB)	ANTENNA FACTOR (dB/m)	CABLE LOSS (dB)	PREAMP FACTOR (dB)	ANTENNA HEIGHT (cm)	TABLE ANGLE (Degree)	REMARK
5126	39.16	38.95	54	-14.84	31.31	6.2	37.3	161	7	Average
5126	60.52	60.31	74	-13.48	31.31	6.2	37.3	161	7	Peak
5300	96.05	95.53			31.44	6.27	37.19	161	7	Average
5300	105.35	104.83			31.44	6.27	37.19	161	7	Peak
5458	39.91	39.09	54	-14.09	31.56	6.34	37.08	161	7	Average
5458	60.48	59.66	74	-13.52	31.56	6.34	37.08	161	7	Peak
ANTENNA POLARITY & TEST DISTANCE: VERTICAL AT 3 M										
FREQ. (MHz)	EMISSION LEVEL (dBuV/m)	READ LEVEL (dBuV)	LIMIT (dBuV/m)	MARGIN (dB)	ANTENNA FACTOR (dB/m)	CABLE LOSS (dB)	PREAMP FACTOR (dB)	ANTENNA HEIGHT (cm)	TABLE ANGLE (Degree)	REMARK
5080	38.04	37.87	54	-15.96	31.27	6.17	37.27	101	344	Average
5080	59.39	59.22	74	-14.61	31.27	6.17	37.27	101	344	Peak
5300	94.09	93.57			31.44	6.27	37.19	101	344	Average
5300	103.51	102.99			31.44	6.27	37.19	101	344	Peak
5360	38.83	38.22	54	-15.17	31.48	6.31	37.18	101	344	Average
5360	59.58	58.97	74	-14.42	31.48	6.31	37.18	101	344	Peak

REMARKS:

- Emission Level = Read Level + Antenna Factor + Cable Loss - Preamp Factor
Margin value = Emission level – Limit value
- 5300MHz: Fundamental frequency.

EUT TEST CONDITION		MEASUREMENT DETAIL	
CHANNEL	Channel 64	FREQUENCY RANGE	1GHz ~ 40GHz
INPUT POWER	120Vac, 60 Hz	DETECTOR FUNCTION	Peak (PK) Average (AV)
ENVIRONMENTAL CONDITIONS	25deg. C, 65%RH	TESTED BY	Anson Lin

ANTENNA POLARITY & TEST DISTANCE: HORIZONTAL AT 3 M										
FREQ. (MHz)	EMISSION LEVEL (dBuV/m)	READ LEVEL (dBuV)	LIMIT (dBuV/m)	MARGIN (dB)	ANTENNA FACTOR (dB/m)	CABLE LOSS (dB)	PREAMP FACTOR (dB)	ANTENNA HEIGHT (cm)	TABLE ANGLE (Degree)	REMARK
5062	38.04	37.87	54	-15.96	31.25	6.17	37.25	153	7	Average
5062	60.23	60.06	74	-13.77	31.25	6.17	37.25	153	7	Peak
5320	95.45	94.9			31.45	6.29	37.19	153	7	Average
5320	105.13	104.58			31.45	6.29	37.19	153	7	Peak
5348	44.86	44.27	54	-9.14	31.48	6.29	37.18	153	7	Average
5348	63.52	62.93	74	-10.48	31.48	6.29	37.18	153	7	Peak
ANTENNA POLARITY & TEST DISTANCE: VERTICAL AT 3 M										
FREQ. (MHz)	EMISSION LEVEL (dBuV/m)	READ LEVEL (dBuV)	LIMIT (dBuV/m)	MARGIN (dB)	ANTENNA FACTOR (dB/m)	CABLE LOSS (dB)	PREAMP FACTOR (dB)	ANTENNA HEIGHT (cm)	TABLE ANGLE (Degree)	REMARK
5074	37.77	37.6	54	-16.23	31.27	6.17	37.27	100	342	Average
5074	60.2	60.03	74	-13.8	31.27	6.17	37.27	100	342	Peak
5320	94.53	93.98			31.45	6.29	37.19	100	342	Average
5320	104.12	103.57			31.45	6.29	37.19	100	342	Peak
5348	42.85	42.26	54	-11.15	31.48	6.29	37.18	100	342	Average
5348	61.4	60.81	74	-12.6	31.48	6.29	37.18	100	342	Peak

REMARKS:

- Emission Level = Read Level + Antenna Factor + Cable Loss - Preamp Factor
Margin value = Emission level – Limit value
- 5320MHz: Fundamental frequency.

EUT TEST CONDITION		MEASUREMENT DETAIL	
CHANNEL	Channel 100	FREQUENCY RANGE	1GHz ~ 40GHz
INPUT POWER	120Vac, 60 Hz	DETECTOR FUNCTION	Peak (PK) Average (AV)
ENVIRONMENTAL CONDITIONS	25deg. C, 65%RH	TESTED BY	Anson Lin

ANTENNA POLARITY & TEST DISTANCE: HORIZONTAL AT 3 M										
FREQ. (MHz)	EMISSION LEVEL (dBuV/m)	READ LEVEL (dBuV)	LIMIT (dBuV/m)	MARGIN (dB)	ANTENNA FACTOR (dB/m)	CABLE LOSS (dB)	PREAMP FACTOR (dB)	ANTENNA HEIGHT (cm)	TABLE ANGLE (Degree)	REMARK
5456	42.44	41.62	54	-11.56	31.56	6.34	37.08	120	149	Average
5456	59.57	58.75	74	-14.43	31.56	6.34	37.08	120	149	Peak
5470	61.6	60.77	68.2	-6.6	31.57	6.34	37.08	120	149	Peak
5500	90.44	89.51			31.6	6.36	37.03	120	149	Average
5500	100.13	99.2			31.6	6.36	37.03	120	149	Peak
5725	59.79	58.51	68.2	-8.41	31.96	6.75	37.43	120	149	Peak
ANTENNA POLARITY & TEST DISTANCE: VERTICAL AT 3 M										
FREQ. (MHz)	EMISSION LEVEL (dBuV/m)	READ LEVEL (dBuV)	LIMIT (dBuV/m)	MARGIN (dB)	ANTENNA FACTOR (dB/m)	CABLE LOSS (dB)	PREAMP FACTOR (dB)	ANTENNA HEIGHT (cm)	TABLE ANGLE (Degree)	REMARK
5460	47.74	46.92	54	-6.26	31.56	6.34	37.08	199	351	Average
5460	63.32	62.5	74	-10.68	31.56	6.34	37.08	199	351	Peak
5470	66.12	65.29	68.2	-2.08	31.57	6.34	37.08	199	351	Peak
5500	97.41	96.48			31.6	6.36	37.03	199	351	Average
5500	107.2	106.27			31.6	6.36	37.03	199	351	Peak
5725	59.67	58.39	68.2	-8.53	31.96	6.75	37.43	199	351	Peak

REMARKS:

- Emission Level = Read Level + Antenna Factor + Cable Loss - Preamp Factor
Margin value = Emission level – Limit value
- 5500MHz: Fundamental frequency.
- 5470MHz & 5725MHz: Out of restricted band

EUT TEST CONDITION		MEASUREMENT DETAIL	
CHANNEL	Channel 116	FREQUENCY RANGE	1GHz ~ 40GHz
INPUT POWER	120Vac, 60 Hz	DETECTOR FUNCTION	Peak (PK) Average (AV)
ENVIRONMENTAL CONDITIONS	25deg. C, 65%RH	TESTED BY	Anson Lin

ANTENNA POLARITY & TEST DISTANCE: HORIZONTAL AT 3 M										
FREQ. (MHz)	EMISSION LEVEL (dBuV/m)	READ LEVEL (dBuV)	LIMIT (dBuV/m)	MARGIN (dB)	ANTENNA FACTOR (dB/m)	CABLE LOSS (dB)	PREAMP FACTOR (dB)	ANTENNA HEIGHT (cm)	TABLE ANGLE (Degree)	REMARK
5406	38.18	37.52	54	-15.82	31.52	6.32	37.18	126	149	Average
5406	60.18	59.52	74	-13.82	31.52	6.32	37.18	126	149	Peak
5470	58.81	57.98	68.2	-9.39	31.57	6.34	37.08	126	149	Peak
5580	89.82	88.78			31.71	6.49	37.16	126	149	Average
5580	100.01	98.97			31.71	6.49	37.16	126	149	Peak
5725	59.6	58.32	68.2	-8.6	31.96	6.75	37.43	126	149	Peak
ANTENNA POLARITY & TEST DISTANCE: VERTICAL AT 3 M										
FREQ. (MHz)	EMISSION LEVEL (dBuV/m)	READ LEVEL (dBuV)	LIMIT (dBuV/m)	MARGIN (dB)	ANTENNA FACTOR (dB/m)	CABLE LOSS (dB)	PREAMP FACTOR (dB)	ANTENNA HEIGHT (cm)	TABLE ANGLE (Degree)	REMARK
5440	38.38	37.62	54	-15.62	31.55	6.34	37.13	212	350	Average
5440	60.99	60.23	74	-13.01	31.55	6.34	37.13	212	350	Peak
5470	59.75	58.92	68.2	-8.45	31.57	6.34	37.08	212	350	Peak
5580	96.64	95.6			31.71	6.49	37.16	212	350	Average
5580	107.45	106.41			31.71	6.49	37.16	212	350	Peak
5725	60.17	58.89	68.2	-8.03	31.96	6.75	37.43	212	350	Peak

REMARKS:

- Emission Level = Read Level + Antenna Factor + Cable Loss - Preamp Factor
Margin value = Emission level – Limit value
- 5580MHz: Fundamental frequency.
- 5470MHz & 5725MHz: Out of restricted band

EUT TEST CONDITION		MEASUREMENT DETAIL	
CHANNEL	Channel 140	FREQUENCY RANGE	1GHz ~ 40GHz
INPUT POWER	120Vac, 60 Hz	DETECTOR FUNCTION	Peak (PK) Average (AV)
ENVIRONMENTAL CONDITIONS	25deg. C, 65%RH	TESTED BY	Anson Lin

ANTENNA POLARITY & TEST DISTANCE: HORIZONTAL AT 3 M										
FREQ. (MHz)	EMISSION LEVEL (dBuV/m)	READ LEVEL (dBuV)	LIMIT (dBuV/m)	MARGIN (dB)	ANTENNA FACTOR (dB/m)	CABLE LOSS (dB)	PREAMP FACTOR (dB)	ANTENNA HEIGHT (cm)	TABLE ANGLE (Degree)	REMARK
5394	38.15	37.51	54	-15.85	31.51	6.31	37.18	112	151	Average
5394	60.55	59.91	74	-13.45	31.51	6.31	37.18	112	151	Peak
5470	59.49	58.66	68.2	-8.71	31.57	6.34	37.08	112	151	Peak
5700	90.85	89.66			31.9	6.69	37.4	112	151	Average
5700	100.73	99.54			31.9	6.69	37.4	112	151	Peak
5725	64.55	63.27	68.2	-3.65	31.96	6.75	37.43	112	151	Peak
ANTENNA POLARITY & TEST DISTANCE: VERTICAL AT 3 M										
FREQ. (MHz)	EMISSION LEVEL (dBuV/m)	READ LEVEL (dBuV)	LIMIT (dBuV/m)	MARGIN (dB)	ANTENNA FACTOR (dB/m)	CABLE LOSS (dB)	PREAMP FACTOR (dB)	ANTENNA HEIGHT (cm)	TABLE ANGLE (Degree)	REMARK
5420	38.28	37.61	54	-15.72	31.53	6.32	37.18	198	350	Average
5420	60.4	59.73	74	-13.6	31.53	6.32	37.18	198	350	Peak
5470	57.89	57.06	68.2	-10.31	31.57	6.34	37.08	198	350	Peak
5700	97	95.81			31.9	6.69	37.4	198	350	Average
5700	107.77	106.58			31.9	6.69	37.4	198	350	Peak
5725	66.05	64.77	68.2	-2.15	31.96	6.75	37.43	198	350	Peak

REMARKS:

- Emission Level = Read Level + Antenna Factor + Cable Loss - Preamp Factor
Margin value = Emission level – Limit value
- 5700MHz: Fundamental frequency.
- 5470MHz & 5725MHz: Out of restricted band



A D T

EUT TEST CONDITION		MEASUREMENT DETAIL	
CHANNEL	Channel 149	FREQUENCY RANGE	1GHz ~ 40GHz
INPUT POWER	120Vac, 60 Hz	DETECTOR FUNCTION	Peak (PK) Average (AV)
ENVIRONMENTAL CONDITIONS	25deg. C, 65%RH	TESTED BY	Anson Lin

ANTENNA POLARITY & TEST DISTANCE: HORIZONTAL AT 3 M										
FREQ. (MHz)	EMISSION LEVEL (dBuV/m)	READ LEVEL (dBuV)	LIMIT (dBuV/m)	MARGIN (dB)	ANTENNA FACTOR (dB/m)	CABLE LOSS (dB)	PREAMP FACTOR (dB)	ANTENNA HEIGHT (cm)	TABLE ANGLE (Degree)	REMARK
5714	64.11	62.92	68.2	-4.09	31.93	6.69	37.43	177	8	Peak
5725	75.64	74.36	78.2	-2.56	31.96	6.75	37.43	177	8	Peak
5745	99.46	98.19			31.99	6.75	37.47	177	8	Average
5745	108.98	107.71			31.99	6.75	37.47	177	8	Peak
5850	60.14	58.62	78.2	-18.06	32.15	6.88	37.51	177	8	Peak
5861	60.67	59.04	68.2	-7.53	32.18	6.95	37.5	177	8	Peak

ANTENNA POLARITY & TEST DISTANCE: VERTICAL AT 3 M										
FREQ. (MHz)	EMISSION LEVEL (dBuV/m)	READ LEVEL (dBuV)	LIMIT (dBuV/m)	MARGIN (dB)	ANTENNA FACTOR (dB/m)	CABLE LOSS (dB)	PREAMP FACTOR (dB)	ANTENNA HEIGHT (cm)	TABLE ANGLE (Degree)	REMARK
5714	61.86	60.67	68.2	-6.34	31.93	6.69	37.43	191	53	Peak
5725	73.01	71.73	78.2	-5.19	31.96	6.75	37.43	191	53	Peak
5745	97.45	96.18			31.99	6.75	37.47	191	53	Average
5745	106.59	105.32			31.99	6.75	37.47	191	53	Peak
5850	59.75	58.23	78.2	-18.45	32.15	6.88	37.51	191	53	Peak
5861	60.76	59.13	68.2	-7.44	32.18	6.95	37.5	191	53	Peak

REMARKS:

1. Emission Level = Read Level + Antenna Factor + Cable Loss - Preamp Factor
Margin value = Emission level – Limit value
2. 5745MHz: Fundamental frequency.
3. 5714MHz & 5725MHz & 5850MHz & 5861MHz: Out of restricted band



A D T

EUT TEST CONDITION		MEASUREMENT DETAIL	
CHANNEL	Channel 157	FREQUENCY RANGE	1GHz ~ 40GHz
INPUT POWER	120Vac, 60 Hz	DETECTOR FUNCTION	Peak (PK) Average (AV)
ENVIRONMENTAL CONDITIONS	25deg. C, 65%RH	TESTED BY	Anson Lin

ANTENNA POLARITY & TEST DISTANCE: HORIZONTAL AT 3 M										
FREQ. (MHz)	EMISSION LEVEL (dBuV/m)	READ LEVEL (dBuV)	LIMIT (dBuV/m)	MARGIN (dB)	ANTENNA FACTOR (dB/m)	CABLE LOSS (dB)	PREAMP FACTOR (dB)	ANTENNA HEIGHT (cm)	TABLE ANGLE (Degree)	REMARK
5714	60.44	59.25	68.2	-7.76	31.93	6.69	37.43	178	28	Peak
5725	60.88	59.6	78.2	-17.32	31.96	6.75	37.43	178	28	Peak
5785	100.18	98.86			32.04	6.82	37.54	178	28	Average
5785	109.52	108.2			32.04	6.82	37.54	178	28	Peak
5850	61.79	60.27	78.2	-16.41	32.15	6.88	37.51	178	28	Peak
5861	60.94	59.31	68.2	-7.26	32.18	6.95	37.5	178	28	Peak
ANTENNA POLARITY & TEST DISTANCE: VERTICAL AT 3 M										
FREQ. (MHz)	EMISSION LEVEL (dBuV/m)	READ LEVEL (dBuV)	LIMIT (dBuV/m)	MARGIN (dB)	ANTENNA FACTOR (dB/m)	CABLE LOSS (dB)	PREAMP FACTOR (dB)	ANTENNA HEIGHT (cm)	TABLE ANGLE (Degree)	REMARK
5714	60.19	59	68.2	-8.01	31.93	6.69	37.43	188	38	Peak
5725	59.78	58.5	78.2	-18.42	31.96	6.75	37.43	188	38	Peak
5785	97.58	96.26			32.04	6.82	37.54	188	38	Average
5785	106.79	105.47			32.04	6.82	37.54	188	38	Peak
5850	61.1	59.58	78.2	-17.1	32.15	6.88	37.51	188	38	Peak
5861	60.32	58.69	68.2	-7.88	32.18	6.95	37.5	188	38	Peak

REMARKS:

- Emission Level = Read Level + Antenna Factor + Cable Loss - Preamp Factor
Margin value = Emission level – Limit value
- 5785MHz: Fundamental frequency.
- 5714MHz & 5725MHz & 5850MHz & 5861MHz: Out of restricted band

EUT TEST CONDITION		MEASUREMENT DETAIL	
CHANNEL	Channel 165	FREQUENCY RANGE	1GHz ~ 40GHz
INPUT POWER	120Vac, 60 Hz	DETECTOR FUNCTION	Peak (PK) Average (AV)
ENVIRONMENTAL CONDITIONS	25deg. C, 65%RH	TESTED BY	Anson Lin

ANTENNA POLARITY & TEST DISTANCE: HORIZONTAL AT 3 M										
FREQ. (MHz)	EMISSION LEVEL (dBuV/m)	READ LEVEL (dBuV)	LIMIT (dBuV/m)	MARGIN (dB)	ANTENNA FACTOR (dB/m)	CABLE LOSS (dB)	PREAMP FACTOR (dB)	ANTENNA HEIGHT (cm)	TABLE ANGLE (Degree)	REMARK
5714	60.03	58.84	68.2	-8.17	31.93	6.69	37.43	174	20	Peak
5725	60.65	59.37	78.2	-17.55	31.96	6.75	37.43	174	20	Peak
5825	99.68	98.21			32.12	6.88	37.53	174	20	Average
5825	108.92	107.45			32.12	6.88	37.53	174	20	Peak
5850	69.91	68.39	78.2	-8.29	32.15	6.88	37.51	174	20	Peak
5861	65.51	63.88	68.2	-2.69	32.18	6.95	37.5	174	20	Peak
ANTENNA POLARITY & TEST DISTANCE: VERTICAL AT 3 M										
FREQ. (MHz)	EMISSION LEVEL (dBuV/m)	READ LEVEL (dBuV)	LIMIT (dBuV/m)	MARGIN (dB)	ANTENNA FACTOR (dB/m)	CABLE LOSS (dB)	PREAMP FACTOR (dB)	ANTENNA HEIGHT (cm)	TABLE ANGLE (Degree)	REMARK
5714	59.65	58.46	68.2	-8.55	31.93	6.69	37.43	206	40	Peak
5725	60.6	59.32	78.2	-17.6	31.96	6.75	37.43	206	40	Peak
5825	97.21	95.74			32.12	6.88	37.53	206	40	Average
5825	106.46	104.99			32.12	6.88	37.53	206	40	Peak
5850	69.8	68.28	78.2	-8.4	32.15	6.88	37.51	206	40	Peak
5861	61.93	60.3	68.2	-6.27	32.18	6.95	37.5	206	40	Peak

REMARKS:

- Emission Level = Read Level + Antenna Factor + Cable Loss - Preamp Factor
Margin value = Emission level – Limit value
- 5825MHz: Fundamental frequency.
- 5714MHz & 5725MHz & 5850MHz & 5861MHz: Out of restricted band

802.11n (40MHz)

EUT TEST CONDITION		MEASUREMENT DETAIL	
CHANNEL	Channel 38	FREQUENCY RANGE	1GHz ~ 40GHz
INPUT POWER	120Vac, 60 Hz	DETECTOR FUNCTION	Peak (PK) Average (AV)
ENVIRONMENTAL CONDITIONS	25deg. C, 65%RH	TESTED BY	Anson Lin

ANTENNA POLARITY & TEST DISTANCE: HORIZONTAL AT 3 M

FREQ. (MHz)	EMISSION LEVEL (dBuV/m)	READ LEVEL (dBuV)	LIMIT (dBuV/m)	MARGIN (dB)	ANTENNA FACTOR (dB/m)	CABLE LOSS (dB)	PREAMP FACTOR (dB)	ANTENNA HEIGHT (cm)	TABLE ANGLE (Degree)	REMARK
5150	51.77	51.57	54	-2.23	31.32	6.2	37.32	187	18	Average
5150	70.04	69.84	74	-3.96	31.32	6.2	37.32	187	18	Peak
5190	92.03	91.8			31.35	6.22	37.34	187	18	Average
5190	101.09	100.86			31.35	6.22	37.34	187	18	Peak
5408	38.6	37.94	54	-15.4	31.52	6.32	37.18	187	18	Average
5408	60.54	59.88	74	-13.46	31.52	6.32	37.18	187	18	Peak

ANTENNA POLARITY & TEST DISTANCE: VERTICAL AT 3 M

FREQ. (MHz)	EMISSION LEVEL (dBuV/m)	READ LEVEL (dBuV)	LIMIT (dBuV/m)	MARGIN (dB)	ANTENNA FACTOR (dB/m)	CABLE LOSS (dB)	PREAMP FACTOR (dB)	ANTENNA HEIGHT (cm)	TABLE ANGLE (Degree)	REMARK
5148	49.33	49.13	54	-4.67	31.32	6.2	37.32	100	144	Average
5148	67.52	67.32	74	-6.48	31.32	6.2	37.32	100	144	Peak
5190	89.62	89.39			31.35	6.22	37.34	100	144	Average
5190	98.66	98.43			31.35	6.22	37.34	100	144	Peak
5426	38.7	37.98	54	-15.3	31.53	6.32	37.13	100	144	Average
5426	61.61	60.89	74	-12.39	31.53	6.32	37.13	100	144	Peak

REMARKS:

- Emission Level = Read Level + Antenna Factor + Cable Loss - Preamp Factor
Margin value = Emission level – Limit value
- 5190MHz: Fundamental frequency.

EUT TEST CONDITION		MEASUREMENT DETAIL	
CHANNEL	Channel 46	FREQUENCY RANGE	1GHz ~ 40GHz
INPUT POWER	120Vac, 60 Hz	DETECTOR FUNCTION	Peak (PK) Average (AV)
ENVIRONMENTAL CONDITIONS	25deg. C, 65%RH	TESTED BY	Anson Lin

ANTENNA POLARITY & TEST DISTANCE: HORIZONTAL AT 3 M										
FREQ. (MHz)	EMISSION LEVEL (dBuV/m)	READ LEVEL (dBuV)	LIMIT (dBuV/m)	MARGIN (dB)	ANTENNA FACTOR (dB/m)	CABLE LOSS (dB)	PREAMP FACTOR (dB)	ANTENNA HEIGHT (cm)	TABLE ANGLE (Degree)	REMARK
5144	40.33	40.13	54	-13.67	31.32	6.2	37.32	153	15	Average
5144	59.84	59.64	74	-14.16	31.32	6.2	37.32	153	15	Peak
5226	92.14	91.83			31.39	6.24	37.32	153	15	Average
5226	101.02	100.71			31.39	6.24	37.32	153	15	Peak
5456	38.52	37.7	54	-15.48	31.56	6.34	37.08	153	15	Average
5456	59.56	58.74	74	-14.44	31.56	6.34	37.08	153	15	Peak
ANTENNA POLARITY & TEST DISTANCE: VERTICAL AT 3 M										
FREQ. (MHz)	EMISSION LEVEL (dBuV/m)	READ LEVEL (dBuV)	LIMIT (dBuV/m)	MARGIN (dB)	ANTENNA FACTOR (dB/m)	CABLE LOSS (dB)	PREAMP FACTOR (dB)	ANTENNA HEIGHT (cm)	TABLE ANGLE (Degree)	REMARK
5014	38.92	38.79	54	-15.08	31.21	6.15	37.23	134	143	Average
5014	60.58	60.45	74	-13.42	31.21	6.15	37.23	134	143	Peak
5230	89.44	89.13			31.39	6.24	37.32	134	143	Average
5230	97.78	97.47			31.39	6.24	37.32	134	143	Peak
5396	38.67	38.02	54	-15.33	31.52	6.31	37.18	134	143	Average
5396	59.84	59.19	74	-14.16	31.52	6.31	37.18	134	143	Peak

REMARKS:

- Emission Level = Read Level + Antenna Factor + Cable Loss - Preamp Factor
Margin value = Emission level – Limit value
- 5226MHz & 5230MHz: Fundamental frequency.



EUT TEST CONDITION		MEASUREMENT DETAIL	
CHANNEL	Channel 54	FREQUENCY RANGE	1GHz ~ 40GHz
INPUT POWER	120Vac, 60 Hz	DETECTOR FUNCTION	Peak (PK) Average (AV)
ENVIRONMENTAL CONDITIONS	25deg. C, 65%RH	TESTED BY	Anson Lin

ANTENNA POLARITY & TEST DISTANCE: HORIZONTAL AT 3 M										
FREQ. (MHz)	EMISSION LEVEL (dBuV/m)	READ LEVEL (dBuV)	LIMIT (dBuV/m)	MARGIN (dB)	ANTENNA FACTOR (dB/m)	CABLE LOSS (dB)	PREAMP FACTOR (dB)	ANTENNA HEIGHT (cm)	TABLE ANGLE (Degree)	REMARK
5022	39	38.86	54	-15	31.23	6.15	37.24	179	9	Average
5022	59.76	59.62	74	-14.24	31.23	6.15	37.24	179	9	Peak
5270	92.22	91.83			31.41	6.25	37.27	179	9	Average
5270	102.27	101.88			31.41	6.25	37.27	179	9	Peak
5448	39.08	38.31	54	-14.92	31.56	6.34	37.13	179	9	Average
5448	60.83	60.06	74	-13.17	31.56	6.34	37.13	179	9	Peak
ANTENNA POLARITY & TEST DISTANCE: VERTICAL AT 3 M										
FREQ. (MHz)	EMISSION LEVEL (dBuV/m)	READ LEVEL (dBuV)	LIMIT (dBuV/m)	MARGIN (dB)	ANTENNA FACTOR (dB/m)	CABLE LOSS (dB)	PREAMP FACTOR (dB)	ANTENNA HEIGHT (cm)	TABLE ANGLE (Degree)	REMARK
5032	38.15	38.01	54	-15.85	31.23	6.15	37.24	101	346	Average
5032	61.51	61.37	74	-12.49	31.23	6.15	37.24	101	346	Peak
5270	89.5	89.11			31.41	6.25	37.27	101	346	Average
5270	98.72	98.33			31.41	6.25	37.27	101	346	Peak
5412	38.58	37.91	54	-15.42	31.53	6.32	37.18	101	346	Average
5412	59.8	59.13	74	-14.2	31.53	6.32	37.18	101	346	Peak

REMARKS:

- Emission Level = Read Level + Antenna Factor + Cable Loss - Preamp Factor
Margin value = Emission level – Limit value
- 5270MHz: Fundamental frequency.



EUT TEST CONDITION		MEASUREMENT DETAIL	
CHANNEL	Channel 62	FREQUENCY RANGE	1GHz ~ 40GHz
INPUT POWER	120Vac, 60 Hz	DETECTOR FUNCTION	Peak (PK) Average (AV)
ENVIRONMENTAL CONDITIONS	25deg. C, 65%RH	TESTED BY	Anson Lin

ANTENNA POLARITY & TEST DISTANCE: HORIZONTAL AT 3 M										
FREQ. (MHz)	EMISSION LEVEL (dBuV/m)	READ LEVEL (dBuV)	LIMIT (dBuV/m)	MARGIN (dB)	ANTENNA FACTOR (dB/m)	CABLE LOSS (dB)	PREAMP FACTOR (dB)	ANTENNA HEIGHT (cm)	TABLE ANGLE (Degree)	REMARK
5122	38.46	38.28	54	-15.54	31.29	6.19	37.3	144	8	Average
5122	60.28	60.1	74	-13.72	31.29	6.19	37.3	144	8	Peak
5310	92.8	92.27			31.45	6.27	37.19	144	8	Average
5310	102.03	101.5			31.45	6.27	37.19	144	8	Peak
5352	51.33	50.74	54	-2.67	31.48	6.29	37.18	144	8	Average
5352	71.67	71.08	74	-2.33	31.48	6.29	37.18	144	8	Peak
ANTENNA POLARITY & TEST DISTANCE: VERTICAL AT 3 M										
FREQ. (MHz)	EMISSION LEVEL (dBuV/m)	READ LEVEL (dBuV)	LIMIT (dBuV/m)	MARGIN (dB)	ANTENNA FACTOR (dB/m)	CABLE LOSS (dB)	PREAMP FACTOR (dB)	ANTENNA HEIGHT (cm)	TABLE ANGLE (Degree)	REMARK
5050	38.42	38.28	54	-15.58	31.24	6.15	37.25	100	344	Average
5050	60.18	60.04	74	-13.82	31.24	6.15	37.25	100	344	Peak
5310	90.04	89.51			31.45	6.27	37.19	100	344	Average
5310	99.4	98.87			31.45	6.27	37.19	100	344	Peak
5350	49.73	49.14	54	-4.27	31.48	6.29	37.18	100	344	Average
5350	66.63	66.04	74	-7.37	31.48	6.29	37.18	100	344	Peak

REMARKS:

- Emission Level = Read Level + Antenna Factor + Cable Loss - Preamp Factor
Margin value = Emission level – Limit value
- 5310MHz: Fundamental frequency.

EUT TEST CONDITION		MEASUREMENT DETAIL	
CHANNEL	Channel 102	FREQUENCY RANGE	1GHz ~ 40GHz
INPUT POWER	120Vac, 60 Hz	DETECTOR FUNCTION	Peak (PK) Average (AV)
ENVIRONMENTAL CONDITIONS	25deg. C, 65%RH	TESTED BY	Anson Lin

ANTENNA POLARITY & TEST DISTANCE: HORIZONTAL AT 3 M										
FREQ. (MHz)	EMISSION LEVEL (dBuV/m)	READ LEVEL (dBuV)	LIMIT (dBuV/m)	MARGIN (dB)	ANTENNA FACTOR (dB/m)	CABLE LOSS (dB)	PREAMP FACTOR (dB)	ANTENNA HEIGHT (cm)	TABLE ANGLE (Degree)	REMARK
5350	41.4	40.81	54	-12.6	31.48	6.29	37.18	127	148	Average
5350	60.39	59.8	74	-13.61	31.48	6.29	37.18	127	148	Peak
5470	61.81	60.98	68.2	-6.39	31.57	6.34	37.08	127	148	Peak
5510	84.39	83.49			31.6	6.36	37.06	127	148	Average
5510	94.77	93.87			31.6	6.36	37.06	127	148	Peak
5725	60.11	58.83	68.2	-8.09	31.96	6.75	37.43	127	148	Peak
ANTENNA POLARITY & TEST DISTANCE: VERTICAL AT 3 M										
FREQ. (MHz)	EMISSION LEVEL (dBuV/m)	READ LEVEL (dBuV)	LIMIT (dBuV/m)	MARGIN (dB)	ANTENNA FACTOR (dB/m)	CABLE LOSS (dB)	PREAMP FACTOR (dB)	ANTENNA HEIGHT (cm)	TABLE ANGLE (Degree)	REMARK
5460	46.05	45.23	54	-7.95	31.56	6.34	37.08	214	50	Average
5460	66.37	65.55	74	-7.63	31.56	6.34	37.08	214	50	Peak
5470	66.19	65.36	68.2	-2.01	31.57	6.34	37.08	214	50	Peak
5510	91.61	90.71			31.6	6.36	37.06	214	50	Average
5510	101.36	100.46			31.6	6.36	37.06	214	50	Peak
5725	61.84	60.56	68.2	-6.36	31.96	6.75	37.43	214	50	Peak

REMARKS:

- Emission Level = Read Level + Antenna Factor + Cable Loss - Preamp Factor
Margin value = Emission level – Limit value
- 5510MHz: Fundamental frequency.
- 5470MHz & 5725MHz: Out of restricted band

EUT TEST CONDITION		MEASUREMENT DETAIL	
CHANNEL	Channel 110	FREQUENCY RANGE	1GHz ~ 40GHz
INPUT POWER	120Vac, 60 Hz	DETECTOR FUNCTION	Peak (PK) Average (AV)
ENVIRONMENTAL CONDITIONS	25deg. C, 65%RH	TESTED BY	Anson Lin

ANTENNA POLARITY & TEST DISTANCE: HORIZONTAL AT 3 M										
FREQ. (MHz)	EMISSION LEVEL (dBuV/m)	READ LEVEL (dBuV)	LIMIT (dBuV/m)	MARGIN (dB)	ANTENNA FACTOR (dB/m)	CABLE LOSS (dB)	PREAMP FACTOR (dB)	ANTENNA HEIGHT (cm)	TABLE ANGLE (Degree)	REMARK
5394	38.52	37.88	54	-15.48	31.51	6.31	37.18	127	152	Average
5394	60.09	59.45	74	-13.91	31.51	6.31	37.18	127	152	Peak
5470	60.36	59.53	68.2	-7.84	31.57	6.34	37.08	127	152	Peak
5550	84.34	83.33			31.68	6.42	37.09	127	152	Average
5550	94.68	93.67			31.68	6.42	37.09	127	152	Peak
5725	59.84	58.56	68.2	-8.36	31.96	6.75	37.43	127	152	Peak
ANTENNA POLARITY & TEST DISTANCE: VERTICAL AT 3 M										
FREQ. (MHz)	EMISSION LEVEL (dBuV/m)	READ LEVEL (dBuV)	LIMIT (dBuV/m)	MARGIN (dB)	ANTENNA FACTOR (dB/m)	CABLE LOSS (dB)	PREAMP FACTOR (dB)	ANTENNA HEIGHT (cm)	TABLE ANGLE (Degree)	REMARK
5444	39.2	38.44	54	-14.8	31.55	6.34	37.13	210	50	Average
5444	60.97	60.21	74	-13.03	31.55	6.34	37.13	210	50	Peak
5470	58.98	58.15	68.2	-9.22	31.57	6.34	37.08	210	50	Peak
5550	91.38	90.37			31.68	6.42	37.09	210	50	Average
5550	101.78	100.77			31.68	6.42	37.09	210	50	Peak
5725	59.15	57.87	68.2	-9.05	31.96	6.75	37.43	210	50	Peak

REMARKS:

- Emission Level = Read Level + Antenna Factor + Cable Loss - Preamp Factor
Margin value = Emission level – Limit value
- 5550MHz: Fundamental frequency.
- 5470MHz & 5725MHz: Out of restricted band



EUT TEST CONDITION		MEASUREMENT DETAIL	
CHANNEL	Channel 134	FREQUENCY RANGE	1GHz ~ 40GHz
INPUT POWER	120Vac, 60 Hz	DETECTOR FUNCTION	Peak (PK) Average (AV)
ENVIRONMENTAL CONDITIONS	25deg. C, 65%RH	TESTED BY	Anson Lin

ANTENNA POLARITY & TEST DISTANCE: HORIZONTAL AT 3 M										
FREQ. (MHz)	EMISSION LEVEL (dBuV/m)	READ LEVEL (dBuV)	LIMIT (dBuV/m)	MARGIN (dB)	ANTENNA FACTOR (dB/m)	CABLE LOSS (dB)	PREAMP FACTOR (dB)	ANTENNA HEIGHT (cm)	TABLE ANGLE (Degree)	REMARK
5460	38.7	37.88	54	-15.3	31.56	6.34	37.08	100	149	Average
5460	61.48	60.66	74	-12.52	31.56	6.34	37.08	100	149	Peak
5470	60.37	59.54	68.2	-7.83	31.57	6.34	37.08	100	149	Peak
5670	85.12	83.96			31.88	6.62	37.34	100	149	Average
5670	94.76	93.6			31.88	6.62	37.34	100	149	Peak
5725	60.55	59.27	68.2	-7.65	31.96	6.75	37.43	100	149	Peak
ANTENNA POLARITY & TEST DISTANCE: VERTICAL AT 3 M										
FREQ. (MHz)	EMISSION LEVEL (dBuV/m)	READ LEVEL (dBuV)	LIMIT (dBuV/m)	MARGIN (dB)	ANTENNA FACTOR (dB/m)	CABLE LOSS (dB)	PREAMP FACTOR (dB)	ANTENNA HEIGHT (cm)	TABLE ANGLE (Degree)	REMARK
5442	38.66	37.9	54	-15.34	31.55	6.34	37.13	200	347	Average
5442	60.63	59.87	74	-13.37	31.55	6.34	37.13	200	347	Peak
5470	58.11	57.28	68.2	-10.09	31.57	6.34	37.08	200	347	Peak
5670	91.56	90.4			31.88	6.62	37.34	200	347	Average
5670	100.81	99.65			31.88	6.62	37.34	200	347	Peak
5725	62.07	60.79	68.2	-6.13	31.96	6.75	37.43	200	347	Peak

REMARKS:

- Emission Level = Read Level + Antenna Factor + Cable Loss - Preamp Factor
Margin value = Emission level – Limit value
- 5670MHz: Fundamental frequency.
- 5470MHz & 5725MHz: Out of restricted band

EUT TEST CONDITION		MEASUREMENT DETAIL	
CHANNEL	Channel 151	FREQUENCY RANGE	1GHz ~ 40GHz
INPUT POWER	120Vac, 60 Hz	DETECTOR FUNCTION	Peak (PK) Average (AV)
ENVIRONMENTAL CONDITIONS	25deg. C, 65%RH	TESTED BY	Anson Lin

ANTENNA POLARITY & TEST DISTANCE: HORIZONTAL AT 3 M										
FREQ. (MHz)	EMISSION LEVEL (dBuV/m)	READ LEVEL (dBuV)	LIMIT (dBuV/m)	MARGIN (dB)	ANTENNA FACTOR (dB/m)	CABLE LOSS (dB)	PREAMP FACTOR (dB)	ANTENNA HEIGHT (cm)	TABLE ANGLE (Degree)	REMARK
5714	66.13	64.94	68.2	-2.07	31.93	6.69	37.43	176	6	Peak
5725	75.6	74.32	78.2	-2.6	31.96	6.75	37.43	176	6	Peak
5755	94.7	93.41			32.01	6.75	37.47	176	6	Average
5755	104.11	102.82			32.01	6.75	37.47	176	6	Peak
5850	60.62	59.1	78.2	-17.58	32.15	6.88	37.51	176	6	Peak
5861	60.37	58.74	68.2	-7.83	32.18	6.95	37.5	176	6	Peak
ANTENNA POLARITY & TEST DISTANCE: VERTICAL AT 3 M										
FREQ. (MHz)	EMISSION LEVEL (dBuV/m)	READ LEVEL (dBuV)	LIMIT (dBuV/m)	MARGIN (dB)	ANTENNA FACTOR (dB/m)	CABLE LOSS (dB)	PREAMP FACTOR (dB)	ANTENNA HEIGHT (cm)	TABLE ANGLE (Degree)	REMARK
5714	65.55	64.36	68.2	-2.65	31.93	6.69	37.43	208	49	Peak
5725	74.13	72.85	78.2	-4.07	31.96	6.75	37.43	208	49	Peak
5755	92.43	91.14			32.01	6.75	37.47	208	49	Average
5755	101.78	100.49			32.01	6.75	37.47	208	49	Peak
5850	59.68	58.16	78.2	-18.52	32.15	6.88	37.51	208	49	Peak
5861	60.32	58.69	68.2	-7.88	32.18	6.95	37.5	208	49	Peak

REMARKS:

- Emission Level = Read Level + Antenna Factor + Cable Loss - Preamp Factor
Margin value = Emission level – Limit value
- 5755MHz: Fundamental frequency.
- 5714MHz & 5725MHz & 5850MHz & 5861MHz: Out of restricted band



EUT TEST CONDITION		MEASUREMENT DETAIL	
CHANNEL	Channel 159	FREQUENCY RANGE	1GHz ~ 40GHz
INPUT POWER	120Vac, 60 Hz	DETECTOR FUNCTION	Peak (PK) Average (AV)
ENVIRONMENTAL CONDITIONS	25deg. C, 65%RH	TESTED BY	Anson Lin

ANTENNA POLARITY & TEST DISTANCE: HORIZONTAL AT 3 M										
FREQ. (MHz)	EMISSION LEVEL (dBuV/m)	READ LEVEL (dBuV)	LIMIT (dBuV/m)	MARGIN (dB)	ANTENNA FACTOR (dB/m)	CABLE LOSS (dB)	PREAMP FACTOR (dB)	ANTENNA HEIGHT (cm)	TABLE ANGLE (Degree)	REMARK
5714	61.19	60	68.2	-7.01	31.93	6.69	37.43	178	11	Peak
5725	62.75	61.47	78.2	-15.45	31.96	6.75	37.43	178	11	Peak
5795	94.94	93.59			32.07	6.82	37.54	178	11	Average
5795	104.2	102.85			32.07	6.82	37.54	178	11	Peak
5850	62.95	61.43	78.2	-15.25	32.15	6.88	37.51	178	11	Peak
5861	65.11	63.48	68.2	-3.09	32.18	6.95	37.5	178	11	Peak
ANTENNA POLARITY & TEST DISTANCE: VERTICAL AT 3 M										
FREQ. (MHz)	EMISSION LEVEL (dBuV/m)	READ LEVEL (dBuV)	LIMIT (dBuV/m)	MARGIN (dB)	ANTENNA FACTOR (dB/m)	CABLE LOSS (dB)	PREAMP FACTOR (dB)	ANTENNA HEIGHT (cm)	TABLE ANGLE (Degree)	REMARK
5714	60.31	59.12	68.2	-7.89	31.93	6.69	37.43	206	42	Peak
5725	61	59.72	78.2	-17.2	31.96	6.75	37.43	206	42	Peak
5795	92.77	91.42			32.07	6.82	37.54	206	42	Average
5795	101.92	100.57			32.07	6.82	37.54	206	42	Peak
5850	62.82	61.3	78.2	-15.38	32.15	6.88	37.51	206	42	Peak
5861	61.03	59.4	68.2	-7.17	32.18	6.95	37.5	206	42	Peak

REMARKS:

- Emission Level = Read Level + Antenna Factor + Cable Loss - Preamp Factor
Margin value = Emission level – Limit value
- 5795MHz: Fundamental frequency.
- 5714MHz & 5725MHz & 5850MHz & 5861MHz: Out of restricted band

9kHz ~ 30MHz DATA:

The amplitude of spurious emissions attenuated more than 20 dB below the permissible value need not be reported

30MHz ~ 1GHz WORST-CASE DATA:
802.11n (40MHz)

EUT TEST CONDITION		MEASUREMENT DETAIL	
CHANNEL	Channel 38	FREQUENCY RANGE	30MHz ~ 1GHz
INPUT POWER	120Vac, 60 Hz	DETECTOR FUNCTION	Peak (PK) Quasi-peak (QP)
ENVIRONMENTAL CONDITIONS	25deg. C, 65%RH	TESTED BY	Anson Lin

ANTENNA POLARITY & TEST DISTANCE: HORIZONTAL AT 3 M										
FREQ. (MHz)	EMISSION LEVEL (dBuV/m)	READ LEVEL (dBuV)	LIMIT (dBuV/m)	MARGIN (dB)	ANTENNA FACTOR (dB/m)	CABLE LOSS (dB)	PREAMP FACTOR (dB)	ANTENNA HEIGHT (cm)	TABLE ANGLE (Degree)	REMARK
89.67	23.26	45.96	43.5	-20.24	8.3	0.96	31.96	127	101	Peak
128.28	26.42	45.61	43.5	-17.08	11.55	1.14	31.88	108	34	Peak
136.11	26.12	44.64	43.5	-17.38	12.08	1.14	31.74	112	224	Peak
601.7	22.77	33.12	46	-23.23	19.62	2.26	32.23	131	176	Peak
715.8	23.74	31.91	46	-22.26	21.04	2.48	31.69	125	330	Peak
806.1	24.97	31.49	46	-21.03	22.3	2.62	31.44	117	347	Peak
ANTENNA POLARITY & TEST DISTANCE: VERTICAL AT 3 M										
FREQ. (MHz)	EMISSION LEVEL (dBuV/m)	READ LEVEL (dBuV)	LIMIT (dBuV/m)	MARGIN (dB)	ANTENNA FACTOR (dB/m)	CABLE LOSS (dB)	PREAMP FACTOR (dB)	ANTENNA HEIGHT (cm)	TABLE ANGLE (Degree)	REMARK
32.7	33.96	51.99	40	-6.04	12.47	0.59	31.09	117	166	Peak
40.8	33.44	50.26	40	-6.56	13.55	0.65	31.02	121	173	Peak
128.55	27.56	46.69	43.5	-15.94	11.61	1.14	31.88	112	128	Peak
685.7	23.26	32.03	46	-22.74	20.64	2.43	31.84	112	336	Peak
774.6	24.78	31.7	46	-21.22	21.87	2.57	31.36	119	50	Peak
863.5	26.1	32.29	46	-19.9	23.04	2.7	31.93	135	35	Peak

REMARKS: Emission Level = Read Level + Antenna Factor + Cable Loss - Preamp Factor

Margin value = Emission level – Limit value

802.11n (40MHz)

EUT TEST CONDITION		MEASUREMENT DETAIL	
CHANNEL	Channel 62	FREQUENCY RANGE	30MHz ~ 1GHz
INPUT POWER	120Vac, 60 Hz	DETECTOR FUNCTION	Peak (PK) Quasi-peak (QP)
ENVIRONMENTAL CONDITIONS	25deg. C, 65%RH	TESTED BY	Anson Lin

ANTENNA POLARITY & TEST DISTANCE: HORIZONTAL AT 3 M

FREQ. (MHz)	EMISSION LEVEL (dBuV/m)	READ LEVEL (dBuV)	LIMIT (dBuV/m)	MARGIN (dB)	ANTENNA FACTOR (dB/m)	CABLE LOSS (dB)	PREAMP FACTOR (dB)	ANTENNA HEIGHT (cm)	TABLE ANGLE (Degree)	REMARK
88.59	24.64	47.29	43.5	-18.86	8.27	0.95	31.87	105	329	Peak
128.01	26.61	45.8	43.5	-16.89	11.55	1.14	31.88	105	303	Peak
134.76	27.57	46.18	43.5	-15.93	12.01	1.14	31.76	139	98	Peak
611.5	21.92	31.99	46	-24.08	19.74	2.28	32.09	102	114	Peak
715.1	24.84	33.03	46	-21.16	21.03	2.48	31.7	125	35	Peak
797.7	24.89	31.51	46	-21.11	22.19	2.61	31.42	118	350	Peak

ANTENNA POLARITY & TEST DISTANCE: VERTICAL AT 3 M

FREQ. (MHz)	EMISSION LEVEL (dBuV/m)	READ LEVEL (dBuV)	LIMIT (dBuV/m)	MARGIN (dB)	ANTENNA FACTOR (dB/m)	CABLE LOSS (dB)	PREAMP FACTOR (dB)	ANTENNA HEIGHT (cm)	TABLE ANGLE (Degree)	REMARK
32.16	34.44	52.66	40	-5.56	12.3	0.59	31.11	102	249	Peak
40.26	31	47.82	40	-9	13.55	0.65	31.02	122	23	Peak
128.55	27.48	46.61	43.5	-16.02	11.61	1.14	31.88	107	199	Peak
595.4	23.13	33.58	46	-22.87	19.5	2.25	32.2	136	323	Peak
720.7	24.1	32.15	46	-21.9	21.11	2.49	31.65	109	285	Peak
780.2	25.51	32.42	46	-20.49	21.94	2.58	31.43	125	142	Peak

REMARKS: Emission Level = Read Level + Antenna Factor + Cable Loss - Preamp Factor

Margin value = Emission level – Limit value

802.11n (40MHz)

EUT TEST CONDITION		MEASUREMENT DETAIL	
CHANNEL	Channel 102	FREQUENCY RANGE	30MHz ~ 1GHz
INPUT POWER	120Vac, 60 Hz	DETECTOR FUNCTION	Peak (PK) Quasi-peak (QP)
ENVIRONMENTAL CONDITIONS	25deg. C, 65%RH	TESTED BY	Anson Lin

ANTENNA POLARITY & TEST DISTANCE: HORIZONTAL AT 3 M

FREQ. (MHz)	EMISSION LEVEL (dBuV/m)	READ LEVEL (dBuV)	LIMIT (dBuV/m)	MARGIN (dB)	ANTENNA FACTOR (dB/m)	CABLE LOSS (dB)	PREAMP FACTOR (dB)	ANTENNA HEIGHT (cm)	TABLE ANGLE (Degree)	REMARK
86.97	24.74	47.36	40	-15.26	8.25	0.95	31.82	106	94	Peak
129.36	27.74	46.87	43.5	-15.76	11.61	1.14	31.88	100	148	Peak
135.84	26.64	45.16	43.5	-16.86	12.08	1.14	31.74	136	90	Peak
533.1	21.86	33.33	46	-24.14	18.08	2.15	31.7	116	287	Peak
645.8	24.44	33.98	46	-21.56	20.16	2.35	32.05	119	22	Peak
764.8	25.13	32.21	46	-20.87	21.74	2.56	31.38	116	44	Peak

ANTENNA POLARITY & TEST DISTANCE: VERTICAL AT 3 M

FREQ. (MHz)	EMISSION LEVEL (dBuV/m)	READ LEVEL (dBuV)	LIMIT (dBuV/m)	MARGIN (dB)	ANTENNA FACTOR (dB/m)	CABLE LOSS (dB)	PREAMP FACTOR (dB)	ANTENNA HEIGHT (cm)	TABLE ANGLE (Degree)	REMARK
32.97	33.67	51.69	40	-6.33	12.47	0.6	31.09	125	286	Peak
41.07	31.17	47.99	40	-8.83	13.55	0.65	31.02	132	34	Peak
129.63	27.56	46.62	43.5	-15.94	11.68	1.14	31.88	125	227	Peak
582.1	21.6	32.3	46	-24.4	19.19	2.23	32.12	114	290	Peak
715.1	23.35	31.54	46	-22.65	21.03	2.48	31.7	101	142	Peak
813.8	26.14	32.62	46	-19.86	22.4	2.63	31.51	127	180	Peak

REMARKS: Emission Level = Read Level + Antenna Factor + Cable Loss - Preamp Factor

Margin value = Emission level – Limit value

802.11n (40MHz)

EUT TEST CONDITION		MEASUREMENT DETAIL	
CHANNEL	Channel 151	FREQUENCY RANGE	30MHz ~ 1GHz
INPUT POWER	120Vac, 60 Hz	DETECTOR FUNCTION	Peak (PK) Quasi-peak (QP)
ENVIRONMENTAL CONDITIONS	25deg. C, 65%RH	TESTED BY	Anson Lin

ANTENNA POLARITY & TEST DISTANCE: HORIZONTAL AT 3 M

FREQ. (MHz)	EMISSION LEVEL (dBuV/m)	READ LEVEL (dBuV)	LIMIT (dBuV/m)	MARGIN (dB)	ANTENNA FACTOR (dB/m)	CABLE LOSS (dB)	PREAMP FACTOR (dB)	ANTENNA HEIGHT (cm)	TABLE ANGLE (Degree)	REMARK
93.18	21.48	43.92	43.5	-22.02	8.53	0.99	31.96	127	345	Peak
128.28	26.74	45.93	43.5	-16.76	11.55	1.14	31.88	138	284	Peak
131.79	25.03	43.91	43.5	-18.47	11.81	1.14	31.83	139	43	Peak
608	22.47	32.6	46	-23.53	19.7	2.28	32.11	112	334	Peak
683.6	25.05	33.85	46	-20.95	20.62	2.42	31.84	120	120	Peak
750.8	24.34	31.59	46	-21.66	21.53	2.53	31.31	136	138	Peak

ANTENNA POLARITY & TEST DISTANCE: VERTICAL AT 3 M

FREQ. (MHz)	EMISSION LEVEL (dBuV/m)	READ LEVEL (dBuV)	LIMIT (dBuV/m)	MARGIN (dB)	ANTENNA FACTOR (dB/m)	CABLE LOSS (dB)	PREAMP FACTOR (dB)	ANTENNA HEIGHT (cm)	TABLE ANGLE (Degree)	REMARK
31.89	33.96	52.18	40	-6.04	12.3	0.59	31.11	119	212	Peak
128.82	27.98	47.11	43.5	-15.52	11.61	1.14	31.88	114	287	Peak
133.68	26.03	44.73	43.5	-17.47	11.94	1.14	31.78	100	264	Peak
639.5	22.71	32.4	46	-23.29	20.08	2.33	32.1	121	24	Peak
728.4	23.77	31.65	46	-22.23	21.22	2.5	31.6	117	314	Peak
783	25.36	32.21	46	-20.64	21.98	2.59	31.42	110	276	Peak

REMARKS: Emission Level = Read Level + Antenna Factor + Cable Loss - Preamp Factor

Margin value = Emission level – Limit value

Mode B
802.11n (40MHz)

EUT TEST CONDITION		MEASUREMENT DETAIL	
CHANNEL	Channel 38	FREQUENCY RANGE	1GHz ~ 40GHz
INPUT POWER	120Vac, 60 Hz	DETECTOR FUNCTION	Peak (PK) Average (AV)
ENVIRONMENTAL CONDITIONS	25deg. C, 65%RH	TESTED BY	Anson Lin

ANTENNA POLARITY & TEST DISTANCE: HORIZONTAL AT 3 M										
FREQ. (MHz)	EMISSION LEVEL (dBuV/m)	READ LEVEL (dBuV)	LIMIT (dBuV/m)	MARGIN (dB)	ANTENNA FACTOR (dB/m)	CABLE LOSS (dB)	PREAMP FACTOR (dB)	ANTENNA HEIGHT (cm)	TABLE ANGLE (Degree)	REMARK
5144	51.7	51.5	54	-2.3	31.32	6.2	37.32	151	9	Average
5144	69.05	68.85	74	-4.95	31.32	6.2	37.32	151	9	Peak
5190	91.8	91.57			31.35	6.22	37.34	151	9	Average
5190	100.91	100.68			31.35	6.22	37.34	151	9	Peak
5434	38.72	37.98	54	-15.28	31.55	6.32	37.13	151	9	Average
5434	60.01	59.27	74	-13.99	31.55	6.32	37.13	151	9	Peak

ANTENNA POLARITY & TEST DISTANCE: VERTICAL AT 3 M										
FREQ. (MHz)	EMISSION LEVEL (dBuV/m)	READ LEVEL (dBuV)	LIMIT (dBuV/m)	MARGIN (dB)	ANTENNA FACTOR (dB/m)	CABLE LOSS (dB)	PREAMP FACTOR (dB)	ANTENNA HEIGHT (cm)	TABLE ANGLE (Degree)	REMARK
5126	49.26	49.05	54	-4.74	31.31	6.2	37.3	107	134	Average
5126	64.65	64.44	74	-9.35	31.31	6.2	37.3	107	134	Peak
5190	88.78	88.55			31.35	6.22	37.34	107	134	Average
5190	97.76	97.53			31.35	6.22	37.34	107	134	Peak
5444	38.54	37.78	54	-15.46	31.55	6.34	37.13	107	134	Average
5444	60.92	60.16	74	-13.08	31.55	6.34	37.13	107	134	Peak

REMARKS:

- Emission Level = Read Level + Antenna Factor + Cable Loss - Preamp Factor
Margin value = Emission level – Limit value
- 5190MHz: Fundamental frequency.

EUT TEST CONDITION		MEASUREMENT DETAIL	
CHANNEL	Channel 62	FREQUENCY RANGE	1GHz ~ 40GHz
INPUT POWER	120Vac, 60 Hz	DETECTOR FUNCTION	Peak (PK) Average (AV)
ENVIRONMENTAL CONDITIONS	25deg. C, 65%RH	TESTED BY	Anson Lin

ANTENNA POLARITY & TEST DISTANCE: HORIZONTAL AT 3 M										
FREQ. (MHz)	EMISSION LEVEL (dBuV/m)	READ LEVEL (dBuV)	LIMIT (dBuV/m)	MARGIN (dB)	ANTENNA FACTOR (dB/m)	CABLE LOSS (dB)	PREAMP FACTOR (dB)	ANTENNA HEIGHT (cm)	TABLE ANGLE (Degree)	REMARK
5096	38.43	38.24	54	-15.57	31.28	6.19	37.28	150	6	Average
5096	60.53	60.34	74	-13.47	31.28	6.19	37.28	150	6	Peak
5310	92.79	92.26			31.45	6.27	37.19	150	6	Average
5310	101.89	101.36			31.45	6.27	37.19	150	6	Peak
5348	51.51	50.92	54	-2.49	31.48	6.29	37.18	150	6	Average
5348	70.25	69.66	74	-3.75	31.48	6.29	37.18	150	6	Peak
ANTENNA POLARITY & TEST DISTANCE: VERTICAL AT 3 M										
FREQ. (MHz)	EMISSION LEVEL (dBuV/m)	READ LEVEL (dBuV)	LIMIT (dBuV/m)	MARGIN (dB)	ANTENNA FACTOR (dB/m)	CABLE LOSS (dB)	PREAMP FACTOR (dB)	ANTENNA HEIGHT (cm)	TABLE ANGLE (Degree)	REMARK
5046	38.27	38.13	54	-15.73	31.24	6.15	37.25	136	139	Average
5046	60.42	60.28	74	-13.58	31.24	6.15	37.25	136	139	Peak
5310	89.96	89.43			31.45	6.27	37.19	136	139	Average
5310	98.71	98.18			31.45	6.27	37.19	136	139	Peak
5348	49.28	48.69	54	-4.72	31.48	6.29	37.18	136	139	Average
5348	68.23	67.64	74	-5.77	31.48	6.29	37.18	136	139	Peak

REMARKS:

- Emission Level = Read Level + Antenna Factor + Cable Loss - Preamp Factor
Margin value = Emission level – Limit value
- 5310MHz: Fundamental frequency.



A D T

EUT TEST CONDITION		MEASUREMENT DETAIL	
CHANNEL	Channel 102	FREQUENCY RANGE	1GHz ~ 40GHz
INPUT POWER	120Vac, 60 Hz	DETECTOR FUNCTION	Peak (PK) Average (AV)
ENVIRONMENTAL CONDITIONS	25deg. C, 65%RH	TESTED BY	Anson Lin

ANTENNA POLARITY & TEST DISTANCE: HORIZONTAL AT 3 M										
FREQ. (MHz)	EMISSION LEVEL (dBuV/m)	READ LEVEL (dBuV)	LIMIT (dBuV/m)	MARGIN (dB)	ANTENNA FACTOR (dB/m)	CABLE LOSS (dB)	PREAMP FACTOR (dB)	ANTENNA HEIGHT (cm)	TABLE ANGLE (Degree)	REMARK
5460	43.77	42.95	54	-10.23	31.56	6.34	37.08	198	239	Average
5460	61.78	60.96	74	-12.22	31.56	6.34	37.08	198	239	Peak
5470	62.66	61.83	68.2	-5.54	31.57	6.34	37.08	198	239	Peak
5510	89.26	88.36			31.6	6.36	37.06	198	239	Average
5510	98.24	97.34			31.6	6.36	37.06	198	239	Peak
5725	58.52	57.24	68.2	-9.68	31.96	6.75	37.43	198	239	Peak

ANTENNA POLARITY & TEST DISTANCE: VERTICAL AT 3 M										
FREQ. (MHz)	EMISSION LEVEL (dBuV/m)	READ LEVEL (dBuV)	LIMIT (dBuV/m)	MARGIN (dB)	ANTENNA FACTOR (dB/m)	CABLE LOSS (dB)	PREAMP FACTOR (dB)	ANTENNA HEIGHT (cm)	TABLE ANGLE (Degree)	REMARK
5460	45.41	44.59	54	-8.59	31.56	6.34	37.08	191	152	Average
5460	63.7	62.88	74	-10.3	31.56	6.34	37.08	191	152	Peak
5470	66.12	65.29	68.2	-2.08	31.57	6.34	37.08	191	152	Peak
5510	91.5	90.6			31.6	6.36	37.06	191	152	Average
5510	100.22	99.32			31.6	6.36	37.06	191	152	Peak
5725	59.55	58.27	68.2	-8.65	31.96	6.75	37.43	191	152	Peak

REMARKS:

1. Emission Level = Read Level + Antenna Factor + Cable Loss - Preamp Factor
Margin value = Emission level – Limit value
2. 5510MHz: Fundamental frequency.
3. 5470MHz & 5725MHz: Out of restricted band

EUT TEST CONDITION		MEASUREMENT DETAIL	
CHANNEL	Channel 151	FREQUENCY RANGE	1GHz ~ 40GHz
INPUT POWER	120Vac, 60 Hz	DETECTOR FUNCTION	Peak (PK) Average (AV)
ENVIRONMENTAL CONDITIONS	25deg. C, 65%RH	TESTED BY	Anson Lin

ANTENNA POLARITY & TEST DISTANCE: HORIZONTAL AT 3 M										
FREQ. (MHz)	EMISSION LEVEL (dBuV/m)	READ LEVEL (dBuV)	LIMIT (dBuV/m)	MARGIN (dB)	ANTENNA FACTOR (dB/m)	CABLE LOSS (dB)	PREAMP FACTOR (dB)	ANTENNA HEIGHT (cm)	TABLE ANGLE (Degree)	REMARK
5714	66.05	64.86	68.2	-2.15	31.93	6.69	37.43	162	356	Peak
5725	76.04	74.76	78.2	-2.16	31.96	6.75	37.43	162	356	Peak
5755	94.52	93.23			32.01	6.75	37.47	162	356	Average
5755	103.7	102.41			32.01	6.75	37.47	162	356	Peak
5850	60.4	58.88	78.2	-17.8	32.15	6.88	37.51	162	356	Peak
5861	60.33	58.7	68.2	-7.87	32.18	6.95	37.5	162	356	Peak
ANTENNA POLARITY & TEST DISTANCE: VERTICAL AT 3 M										
FREQ. (MHz)	EMISSION LEVEL (dBuV/m)	READ LEVEL (dBuV)	LIMIT (dBuV/m)	MARGIN (dB)	ANTENNA FACTOR (dB/m)	CABLE LOSS (dB)	PREAMP FACTOR (dB)	ANTENNA HEIGHT (cm)	TABLE ANGLE (Degree)	REMARK
5714	63.95	62.76	68.2	-4.25	31.93	6.69	37.43	167	226	Peak
5725	71.39	70.11	78.2	-6.81	31.96	6.75	37.43	167	226	Peak
5755	91.17	89.88			32.01	6.75	37.47	167	226	Average
5755	100.26	98.97			32.01	6.75	37.47	167	226	Peak
5850	59.44	57.92	78.2	-18.76	32.15	6.88	37.51	167	226	Peak
5861	60.83	59.2	68.2	-7.37	32.18	6.95	37.5	167	226	Peak

REMARKS:

- Emission Level = Read Level + Antenna Factor + Cable Loss - Preamp Factor
Margin value = Emission level – Limit value
- 5755MHz: Fundamental frequency.
- 5714MHz & 5725MHz & 5850MHz & 5861MHz: Out of restricted band

9kHz ~ 30MHz DATA:

The amplitude of spurious emissions attenuated more than 20 dB below the permissible value need not be reported

30MHz ~ 1GHz WORST-CASE DATA:
802.11n (40MHz)

EUT TEST CONDITION		MEASUREMENT DETAIL	
CHANNEL	Channel 38	FREQUENCY RANGE	30MHz ~ 1GHz
INPUT POWER	120Vac, 60 Hz	DETECTOR FUNCTION	Peak (PK) Quasi-peak (QP)
ENVIRONMENTAL CONDITIONS	25deg. C, 65%RH	TESTED BY	Anson Lin

ANTENNA POLARITY & TEST DISTANCE: HORIZONTAL AT 3 M										
FREQ. (MHz)	EMISSION LEVEL (dBuV/m)	READ LEVEL (dBuV)	LIMIT (dBuV/m)	MARGIN (dB)	ANTENNA FACTOR (dB/m)	CABLE LOSS (dB)	PREAMP FACTOR (dB)	ANTENNA HEIGHT (cm)	TABLE ANGLE (Degree)	REMARK
32.16	25.09	43.31	40	-14.91	12.3	0.59	31.11	123	282	Peak
72.39	27.77	48.61	40	-12.23	10.05	0.85	31.74	132	208	Peak
135.57	29.77	48.29	43.5	-13.73	12.08	1.14	31.74	126	254	Peak
319.6	20.03	36.81	46	-25.97	13.43	1.68	31.89	128	233	Peak
480.6	20.87	33.71	46	-25.13	16.95	2.05	31.84	106	270	Peak
568.1	22.62	33.62	46	-23.38	18.88	2.2	32.08	132	226	Peak
ANTENNA POLARITY & TEST DISTANCE: VERTICAL AT 3 M										
FREQ. (MHz)	EMISSION LEVEL (dBuV/m)	READ LEVEL (dBuV)	LIMIT (dBuV/m)	MARGIN (dB)	ANTENNA FACTOR (dB/m)	CABLE LOSS (dB)	PREAMP FACTOR (dB)	ANTENNA HEIGHT (cm)	TABLE ANGLE (Degree)	REMARK
32.43	34.67	52.7	40	-5.33	12.47	0.59	31.09	103	240	Peak
41.61	34.25	51.08	40	-5.75	13.56	0.66	31.05	138	219	Peak
65.64	32.77	52.32	40	-7.23	11.24	0.85	31.64	131	345	Peak
395.2	18.6	33.57	46	-27.4	15.21	1.9	32.08	139	145	Peak
515.6	23.61	35.39	46	-22.39	17.68	2.12	31.58	112	279	Peak
667.5	23.66	32.7	46	-22.34	20.42	2.39	31.85	140	221	Peak

REMARKS: Emission Level = Read Level + Antenna Factor + Cable Loss - Preamp Factor

Margin value = Emission level – Limit value

802.11n (40MHz)

EUT TEST CONDITION		MEASUREMENT DETAIL	
CHANNEL	Channel 62	FREQUENCY RANGE	30MHz ~ 1GHz
INPUT POWER	120Vac, 60 Hz	DETECTOR FUNCTION	Peak (PK) Quasi-peak (QP)
ENVIRONMENTAL CONDITIONS	25deg. C, 65%RH	TESTED BY	Anson Lin

ANTENNA POLARITY & TEST DISTANCE: HORIZONTAL AT 3 M

FREQ. (MHz)	EMISSION LEVEL (dBuV/m)	READ LEVEL (dBuV)	LIMIT (dBuV/m)	MARGIN (dB)	ANTENNA FACTOR (dB/m)	CABLE LOSS (dB)	PREAMP FACTOR (dB)	ANTENNA HEIGHT (cm)	TABLE ANGLE (Degree)	REMARK
32.7	25.38	43.41	40	-14.62	12.47	0.59	31.09	128	257	Peak
72.66	27.09	47.93	40	-12.91	10.05	0.85	31.74	123	124	Peak
134.76	29.57	48.18	43.5	-13.93	12.01	1.14	31.76	119	258	Peak
360.2	20.15	35.94	46	-25.85	14.38	1.8	31.97	137	301	Peak
507.9	21.46	33.44	46	-24.54	17.51	2.11	31.6	138	31	Peak
571.6	23.46	34.38	46	-22.54	18.95	2.21	32.08	128	30	Peak

ANTENNA POLARITY & TEST DISTANCE: VERTICAL AT 3 M

FREQ. (MHz)	EMISSION LEVEL (dBuV/m)	READ LEVEL (dBuV)	LIMIT (dBuV/m)	MARGIN (dB)	ANTENNA FACTOR (dB/m)	CABLE LOSS (dB)	PREAMP FACTOR (dB)	ANTENNA HEIGHT (cm)	TABLE ANGLE (Degree)	REMARK
32.7	34.36	52.39	40	-5.64	12.47	0.59	31.09	105	348	Peak
41.61	34.45	51.28	40	-5.55	13.56	0.66	31.05	120	208	Peak
65.37	32.56	51.95	40	-7.44	11.35	0.85	31.59	134	350	Peak
386.8	19.08	34.19	46	-26.92	15.03	1.87	32.01	112	115	Peak
519.1	23.05	34.75	46	-22.95	17.75	2.12	31.57	131	42	Peak
634.6	23.64	33.42	46	-22.36	20.02	2.32	32.12	103	38	Peak

REMARKS: Emission Level = Read Level + Antenna Factor + Cable Loss - Preamp Factor

Margin value = Emission level – Limit value

802.11n (40MHz)

EUT TEST CONDITION		MEASUREMENT DETAIL	
CHANNEL	Channel 102	FREQUENCY RANGE	30MHz ~ 1GHz
INPUT POWER	120Vac, 60 Hz	DETECTOR FUNCTION	Peak (PK) Quasi-peak (QP)
ENVIRONMENTAL CONDITIONS	25deg. C, 65%RH	TESTED BY	Anson Lin

ANTENNA POLARITY & TEST DISTANCE: HORIZONTAL AT 3 M

FREQ. (MHz)	EMISSION LEVEL (dBuV/m)	READ LEVEL (dBuV)	LIMIT (dBuV/m)	MARGIN (dB)	ANTENNA FACTOR (dB/m)	CABLE LOSS (dB)	PREAMP FACTOR (dB)	ANTENNA HEIGHT (cm)	TABLE ANGLE (Degree)	REMARK
41.07	24.39	41.21	40	-15.61	13.55	0.65	31.02	118	3	Peak
71.85	27.54	48.16	40	-12.46	10.29	0.85	31.76	116	325	Peak
135.84	29.48	48	43.5	-14.02	12.08	1.14	31.74	114	314	Peak
318.9	21.16	37.98	46	-24.84	13.4	1.68	31.9	126	212	Peak
489	21.2	33.81	46	-24.8	17.1	2.07	31.78	122	39	Peak
587	24.27	34.86	46	-21.73	19.3	2.24	32.13	119	41	Peak

ANTENNA POLARITY & TEST DISTANCE: VERTICAL AT 3 M

FREQ. (MHz)	EMISSION LEVEL (dBuV/m)	READ LEVEL (dBuV)	LIMIT (dBuV/m)	MARGIN (dB)	ANTENNA FACTOR (dB/m)	CABLE LOSS (dB)	PREAMP FACTOR (dB)	ANTENNA HEIGHT (cm)	TABLE ANGLE (Degree)	REMARK
32.43	33.66	51.69	40	-6.34	12.47	0.59	31.09	128	131	Peak
41.07	33.46	50.28	40	-6.54	13.55	0.65	31.02	101	194	Peak
64.83	31.54	50.94	40	-8.46	11.35	0.84	31.59	105	31	Peak
348.3	18.56	34.54	46	-27.44	14.1	1.76	31.84	129	191	Peak
514.2	23.67	35.49	46	-22.33	17.64	2.12	31.58	121	216	Peak
618.5	23.46	33.5	46	-22.54	19.83	2.29	32.16	130	240	Peak

REMARKS: Emission Level = Read Level + Antenna Factor + Cable Loss - Preamp Factor

Margin value = Emission level – Limit value

802.11n (40MHz)

EUT TEST CONDITION		MEASUREMENT DETAIL	
CHANNEL	Channel 151	FREQUENCY RANGE	30MHz ~ 1GHz
INPUT POWER	120Vac, 60 Hz	DETECTOR FUNCTION	Peak (PK) Quasi-peak (QP)
ENVIRONMENTAL CONDITIONS	25deg. C, 65%RH	TESTED BY	Anson Lin

ANTENNA POLARITY & TEST DISTANCE: HORIZONTAL AT 3 M

FREQ. (MHz)	EMISSION LEVEL (dBuV/m)	READ LEVEL (dBuV)	LIMIT (dBuV/m)	MARGIN (dB)	ANTENNA FACTOR (dB/m)	CABLE LOSS (dB)	PREAMP FACTOR (dB)	ANTENNA HEIGHT (cm)	TABLE ANGLE (Degree)	REMARK
41.61	24.79	41.62	40	-15.21	13.56	0.66	31.05	133	34	Peak
73.2	27.09	48.14	40	-12.91	9.81	0.85	31.71	135	275	Peak
136.38	29.42	47.85	43.5	-14.08	12.14	1.14	31.71	132	47	Peak
367.9	19.42	34.98	46	-26.58	14.56	1.81	31.93	130	66	Peak
508.6	21.33	33.31	46	-24.67	17.51	2.11	31.6	135	331	Peak
655.6	24.11	33.44	46	-21.89	20.28	2.37	31.98	103	136	Peak

ANTENNA POLARITY & TEST DISTANCE: VERTICAL AT 3 M

FREQ. (MHz)	EMISSION LEVEL (dBuV/m)	READ LEVEL (dBuV)	LIMIT (dBuV/m)	MARGIN (dB)	ANTENNA FACTOR (dB/m)	CABLE LOSS (dB)	PREAMP FACTOR (dB)	ANTENNA HEIGHT (cm)	TABLE ANGLE (Degree)	REMARK
32.7	34.2	52.23	40	-5.8	12.47	0.59	31.09	103	338	Peak
40.8	34.43	51.25	40	-5.57	13.55	0.65	31.02	101	115	Peak
65.1	32.93	52.32	40	-7.07	11.35	0.85	31.59	132	59	Peak
423.9	19.75	34.02	46	-26.25	15.81	1.95	32.03	132	239	Peak
523.3	23.4	35.03	46	-22.6	17.86	2.13	31.62	112	36	Peak
693.4	24.2	32.84	46	-21.8	20.74	2.44	31.82	111	13	Peak

REMARKS: Emission Level = Read Level + Antenna Factor + Cable Loss - Preamp Factor

Margin value = Emission level – Limit value

4.2 Conducted Emission Measurement

4.2.1 Limits of Conducted Emission Measurement

Frequency (MHz)	Conducted Limit (dBuV)	
	Quasi-peak	Average
0.15 - 0.5	66 - 56	56 - 46
0.50 - 5.0	56	46
5.0 - 30.0	60	50

Note: 1. The lower limit shall apply at the transition frequencies.

2. The limit decreases in line with the logarithm of the frequency in the range of 0.15 to 0.50MHz.

4.2.2 Test Instruments

Description & Manufacturer	Model No.	Serial No.	Date Of Calibration	Due Date Of Calibration
Test Receiver ROHDE & SCHWARZ	ESCI	100613	Nov. 11, 2014	Nov. 10, 2015
RF signal cable Woken	5D-FB	Cable-HYC01-01	Dec. 26, 2014	Dec. 25, 2015
LISN ROHDE & SCHWARZ (EUT)	ESH3-Z5	835239/001	Feb. 26, 2015	Feb. 25, 2016
LISN ROHDE & SCHWARZ (Peripheral)	ESH3-Z5	100311	Jul. 24, 2015	Jul. 23, 2016
Software ADT	BV ADT_Cond_ V7.3.7.3	NA	NA	NA

- Note:**
1. The calibration interval of the above test instruments is 12 months and the calibrations are traceable to NML/ROC and NIST/USA.
 2. The test was performed in HwaYa Shielded Room 1.
 3. The VCCI Site Registration No. is C-2040.

4.2.3 Test Procedures

- a. The EUT was placed 0.4 meters from the conducting wall of the shielded room with EUT being connected to the power mains through a line impedance stabilization network (LISN). Other support units were connected to the power mains through another LISN. The two LISNs provide 50 ohm/ 50uH of coupling impedance for the measuring instrument.
- b. Both lines of the power mains connected to the EUT were checked for maximum conducted interference.
- c. The frequency range from 150kHz to 30MHz was searched. Emission levels under (Limit - 20dB) was not recorded.

NOTE: All modes of operation were investigated and the worst-case emissions are reported.

4.2.4 Deviation from Test Standard

No deviation.

4.2.5 Test Setup

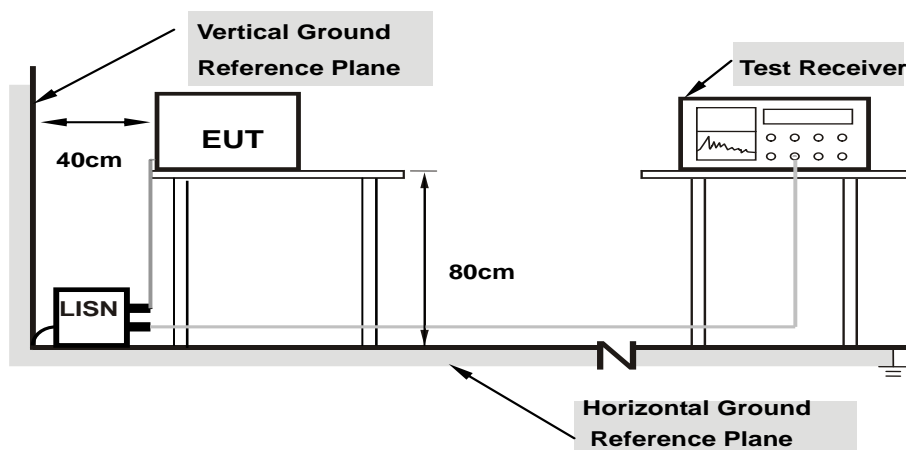

- Note:**
1. Support units were connected to second LISN.
 2. Both of LISNs (AMN) are 80 cm from EUT and at least 80 from other units and other metal planes

For the actual test configuration, please refer to the attached file (Test Setup Photo).

4.2.6 EUT Operating Conditions

Same as 4.1.6.

4.2.7 Test Results

Mode A

Frequency Range	150kHz ~ 30MHz	Detector Function & Resolution Bandwidth	Quasi-Peak (QP) / Average (AV), 9kHz
Input Power	120Vac, 60Hz	Environmental Conditions	25°C, 65%RH
Tested by	Toby Tian	Test Date	2015/8/12

Phase Of Power : Line (L)										
No	Frequency (MHz)	Correction Factor (dB)	Reading Value (dBuV)		Emission Level (dBuV)		Limit (dBuV)		Margin (dB)	
			Q.P.	AV.	Q.P.	AV.	Q.P.	AV.	Q.P.	AV.
1	0.16569	0.05	36.54	14.46	36.59	14.51	65.17	55.17	-28.58	-40.66
2	0.20838	0.06	53.03	34.53	53.09	34.59	63.27	53.27	-10.18	-18.68
3	0.26339	0.06	46.14	30.28	46.20	30.34	61.32	51.32	-15.12	-20.98
4	0.32204	0.06	41.49	27.09	41.55	27.15	59.65	49.65	-18.10	-22.50
5	0.40415	0.06	38.11	22.52	38.17	22.58	57.77	47.77	-19.60	-25.19
6	0.51448	0.06	34.14	19.77	34.20	19.83	56.00	46.00	-21.80	-26.17

Remarks:

1. Q.P. and AV. are abbreviations of quasi-peak and average individually.
2. The emission levels of other frequencies were very low against the limit.
3. Margin value = Emission level – Limit value
4. Correction factor = Insertion loss + Cable loss
5. Emission Level = Correction Factor + Reading Value

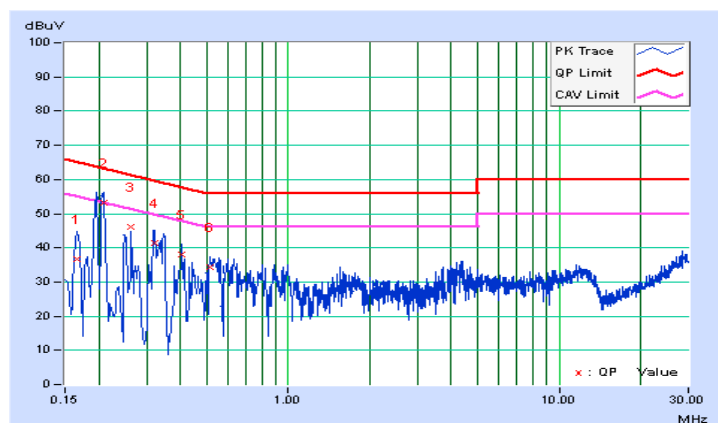

Frequency Range	150kHz ~ 30MHz	Detector Function & Resolution Bandwidth	Quasi-Peak (QP) / Average (AV), 9kHz
Input Power	120Vac, 60Hz	Environmental Conditions	25°C, 65%RH
Tested by	Toby Tian	Test Date	2015/8/12

Phase Of Power : Neutral (N)										
No	Frequency (MHz)	Correction Factor (dB)	Reading Value (dBuV)		Emission Level (dBuV)		Limit (dBuV)		Margin (dB)	
			Q.P.	AV.	Q.P.	AV.	Q.P.	AV.	Q.P.	AV.
1	0.15000	0.05	45.66	25.77	45.71	25.82	66.00	56.00	-20.29	-30.18
2	0.18508	0.05	53.91	33.49	53.96	33.54	64.25	54.25	-10.29	-20.71
3	0.25948	0.05	47.36	33.29	47.41	33.34	61.45	51.45	-14.04	-18.11
4	0.32595	0.06	40.97	25.78	41.03	25.84	59.55	49.55	-18.53	-23.72
5	0.39242	0.06	40.36	27.15	40.42	27.21	58.01	48.01	-17.59	-20.80
6	0.48626	0.06	35.75	18.60	35.81	18.66	56.23	46.23	-20.42	-27.57

Remarks:

1. Q.P. and AV. are abbreviations of quasi-peak and average individually.
2. The emission levels of other frequencies were very low against the limit.
3. Margin value = Emission level – Limit value
4. Correction factor = Insertion loss + Cable loss
5. Emission Level = Correction Factor + Reading Value

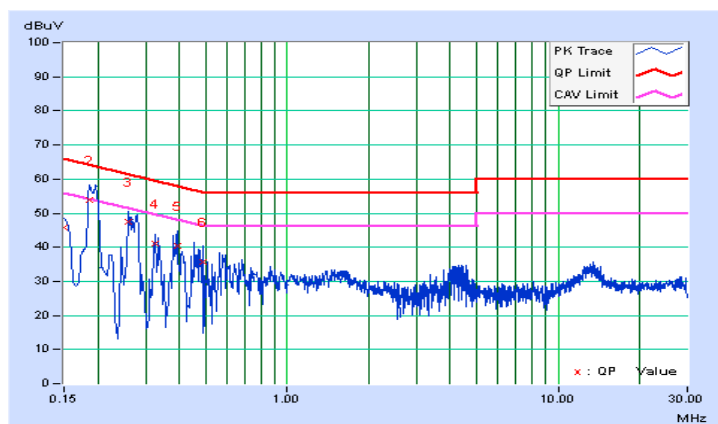

Mode B

Frequency Range	150kHz ~ 30MHz	Detector Function & Resolution Bandwidth	Quasi-Peak (QP) / Average (AV), 9kHz
Input Power	120Vac, 60Hz	Environmental Conditions	25°C, 65%RH
Tested by	Toby Tian	Test Date	2015/8/20

Phase Of Power : Line (L)										
No	Frequency (MHz)	Correction Factor (dB)	Reading Value (dBuV)		Emission Level (dBuV)		Limit (dBuV)		Margin (dB)	
			Q.P.	AV.	Q.P.	AV.	Q.P.	AV.	Q.P.	AV.
1	0.15391	0.05	41.89	29.10	41.94	29.15	65.79	55.79	-23.85	-26.64
2	0.19305	0.06	54.67	39.59	54.73	39.65	63.90	53.90	-9.18	-14.26
3	0.26695	0.06	45.50	30.26	45.56	30.32	61.21	51.21	-15.65	-20.89
4	0.37678	0.06	38.99	20.51	39.05	20.57	58.35	48.35	-19.30	-27.78
5	0.57228	0.07	35.26	20.89	35.33	20.96	56.00	46.00	-20.67	-25.04
6	4.23986	0.20	33.90	18.08	34.10	18.28	56.00	46.00	-21.90	-27.72

Remarks:

1. Q.P. and AV. are abbreviations of quasi-peak and average individually.
2. The emission levels of other frequencies were very low against the limit.
3. Margin value = Emission level – Limit value
4. Correction factor = Insertion loss + Cable loss
5. Emission Level = Correction Factor + Reading Value

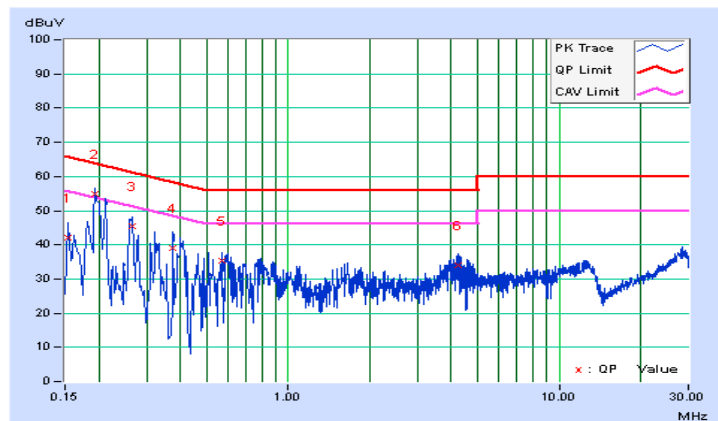

Frequency Range	150kHz ~ 30MHz	Detector Function & Resolution Bandwidth	Quasi-Peak (QP) / Average (AV), 9kHz
Input Power	120Vac, 60Hz	Environmental Conditions	25°C, 65%RH
Tested by	Toby Tian	Test Date	2015/8/20

Phase Of Power : Neutral (N)										
No	Frequency (MHz)	Correction Factor (dB)	Reading Value (dBuV)		Emission Level (dBuV)		Limit (dBuV)		Margin (dB)	
			Q.P.	AV.	Q.P.	AV.	Q.P.	AV.	Q.P.	AV.
1	0.15000	0.05	45.16	27.80	45.21	27.85	66.00	56.00	-20.79	-28.15
2	0.19717	0.05	55.64	42.53	55.69	42.58	63.73	53.73	-8.04	-11.15
3	0.25192	0.05	46.63	29.51	46.68	29.56	61.69	51.69	-15.01	-22.13
4	0.34926	0.06	39.69	21.61	39.75	21.67	58.98	48.98	-19.23	-27.31
5	0.46301	0.06	39.08	26.56	39.14	26.62	56.64	46.64	-17.50	-20.02
6	0.65044	0.07	34.69	19.81	34.76	19.88	56.00	46.00	-21.24	-26.12

Remarks:

1. Q.P. and AV. are abbreviations of quasi-peak and average individually.
2. The emission levels of other frequencies were very low against the limit.
3. Margin value = Emission level – Limit value
4. Correction factor = Insertion loss + Cable loss
5. Emission Level = Correction Factor + Reading Value

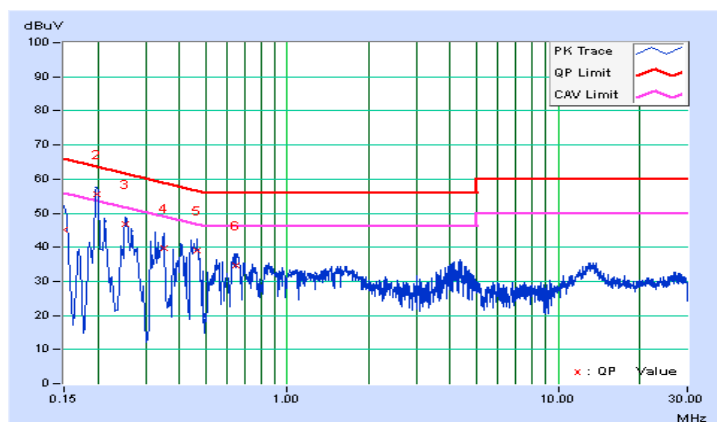

4.3 Transmit Power Measurement

4.3.1 Limits of Transmit Power Measurement

Operation Band	EUT Category		LIMIT
U-NII-1		Outdoor Access Point	1 Watt (30 dBm) (Max. e.i.r.p \leq 125mW(21 dBm) at any elevation angle above 30 degrees as measured from the horizon)
		Fixed point-to-point Access Point	1 Watt (30 dBm)
		Indoor Access Point	1 Watt (30 dBm)
	√	Mobile and Portable client device	250mW (24 dBm)
U-NII-2A		√	250mW (24 dBm) or 11 dBm+10 log B*
U-NII-2C		√	250mW (24 dBm) or 11 dBm+10 log B*
U-NII-3		√	1 Watt (30 dBm)

*B is the 26 dB emission bandwidth in megahertz

Per KDB 662911 Method of conducted output power measurement on IEEE 802.11 devices,

Array Gain = 0 dB (i.e., no array gain) for $N_{ANT} \leq 4$;

Array Gain = 0 dB (i.e., no array gain) for channel widths ≥ 40 MHz for any N_{ANT} ;

Array Gain = $5 \log(N_{ANT}/N_{SS})$ dB or 3 dB, whichever is less for 20-MHz channel widths with $N_{ANT} \geq 5$.

For power measurements on all other devices: Array Gain = $10 \log(N_{ANT}/N_{SS})$ dB.

4.3.2 Test Setup

FOR POWER OUTPUT MEASUREMENT

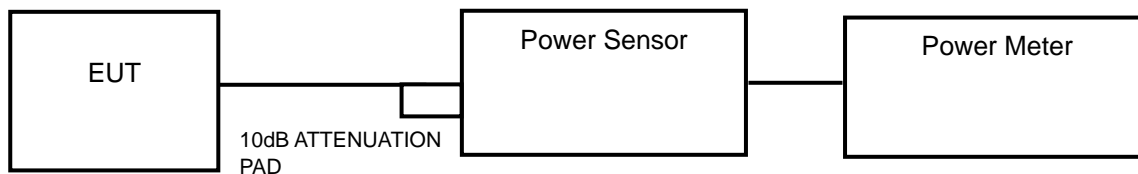

FOR 26dB BANDWIDTH

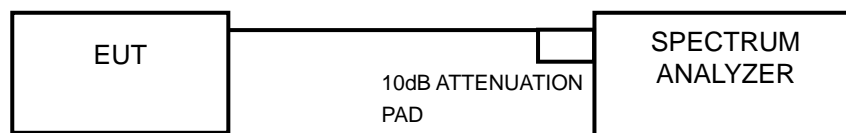

4.3.3 Test Instruments

Refer to section 4.1.2 to get information of above instrument.

4.3.4 Test Procedure

FOR AVERAGE POWER MEASUREMENT

Method PM is used to perform output power measurement, trigger and gating function of wide band power meter is enabled to measure max output power of TX on burst. Duty factor is not added to measured value.

FOR 26dB BANDWIDTH

- 1) Set RBW = approximately 1% of the emission bandwidth.
- 2) Set the VBW > RBW.
- 3) Detector = Peak.
- 4) Trace mode = max hold.
- 5) Measure the maximum width of the emission that is 26 dB down from the peak of the emission. Compare this with the RBW setting of the analyzer. Readjust RBW and repeat measurement as needed until the RBW/EBW ratio is approximately 1%.

4.3.5 Deviation from Test Standard

No deviation.

4.3.6 EUT Operating Conditions

The software provided by client to enable the EUT under transmission condition continuously at lowest, middle and highest channel frequencies individually.

4.3.7 Test Result

POWER OUTPUT:

802.11a

Channel	Frequency (MHz)	Maximum Conducted Power (mW)	Maximum Conducted Power (dBm)	Power Limit (dBm)	Pass / Fail
36	5180	39.90	16.01	30	Pass
44	5220	38.64	15.87	30	Pass
48	5240	37.24	15.71	30	Pass
52	5260	36.14	15.58	24	Pass
60	5300	34.59	15.39	24	Pass
64	5320	33.96	15.31	24	Pass
100	5500	32.58	15.13	24	Pass
116	5580	31.41	14.97	24	Pass
140	5700	30.06	14.78	24	Pass
149	5745	30.55	14.85	30	Pass
157	5785	30.83	14.89	30	Pass
165	5825	29.04	14.63	30	Pass

NOTE:

For U-NII-2A, U-NII-2C Band:

1. $11\text{dBm} + 10\log(40.90) = 27.12\text{ dBm} > 24\text{dBm}$.
2. $11\text{dBm} + 10\log(40.88) = 27.12\text{ dBm} > 24\text{dBm}$.
3. $11\text{dBm} + 10\log(39.40) = 26.95\text{ dBm} > 24\text{dBm}$.
4. $11\text{dBm} + 10\log(36.16) = 26.58\text{ dBm} > 24\text{dBm}$.
5. $11\text{dBm} + 10\log(37.37) = 26.73\text{ dBm} > 24\text{dBm}$.
6. $11\text{dBm} + 10\log(39.61) = 26.98\text{ dBm} > 24\text{dBm}$.

802.11n (20MHz)

Channel	Frequency (MHz)	Maximum Conducted Power (mW)	Maximum Conducted Power (dBm)	Power Limit (dBm)	Pass / Fail
36	5180	40.93	16.12	30	Pass
44	5220	39.26	15.94	30	Pass
48	5240	38.02	15.80	30	Pass
52	5260	38.28	15.83	24	Pass
60	5300	37.07	15.69	24	Pass
64	5320	37.41	15.73	24	Pass
100	5500	33.42	15.24	24	Pass
116	5580	31.70	15.01	24	Pass
140	5700	31.05	14.92	24	Pass
149	5745	30.76	14.88	30	Pass
157	5785	30.97	14.91	30	Pass
165	5825	29.79	14.74	30	Pass

NOTE:
For U-NII-2A, U-NII-2C Band:

1. $11\text{dBm} + 10\log(38.29) = 26.83\text{ dBm} > 24\text{dBm}$.
2. $11\text{dBm} + 10\log(41.52) = 27.18\text{ dBm} > 24\text{dBm}$.
3. $11\text{dBm} + 10\log(38.19) = 26.82\text{ dBm} > 24\text{dBm}$.
4. $11\text{dBm} + 10\log(37.76) = 26.77\text{ dBm} > 24\text{dBm}$.
5. $11\text{dBm} + 10\log(39.43) = 26.96\text{ dBm} > 24\text{dBm}$.
6. $11\text{dBm} + 10\log(40.64) = 27.09\text{ dBm} > 24\text{dBm}$.

802.11n (40MHz)

Channel	Frequency (MHz)	Maximum Conducted Power (mW)	Maximum Conducted Power (dBm)	Power Limit (dBm)	Pass / Fail
38	5190	24.83	13.95	30	Pass
46	5230	24.43	13.88	30	Pass
54	5270	25.41	14.05	24	Pass
62	5310	25.35	14.04	24	Pass
102	5510	20.04	13.02	24	Pass
110	5550	19.82	12.97	24	Pass
134	5670	19.23	12.84	24	Pass
151	5755	19.32	12.86	30	Pass
159	5795	19.77	12.96	30	Pass

NOTE:
For U-NII-2A, U-NII-2C Band:

1. $11\text{dBm} + 10\log(74.73) = 29.73\text{ dBm} > 24\text{dBm}$.
2. $11\text{dBm} + 10\log(75.15) = 29.76\text{ dBm} > 24\text{dBm}$.
3. $11\text{dBm} + 10\log(71.49) = 29.54\text{ dBm} > 24\text{dBm}$.
4. $11\text{dBm} + 10\log(71.14) = 29.52\text{ dBm} > 24\text{dBm}$.
5. $11\text{dBm} + 10\log(77.77) = 29.91\text{ dBm} > 24\text{dBm}$.

26dB BANDWIDTH:
802.11a

Channel	Frequency (MHz)	26dBc Bandwidth (MHz)	Pass / Fail
36	5180	38.82	Pass
44	5220	40.99	Pass
48	5240	39.55	Pass
52	5260	40.90	Pass
60	5300	40.88	Pass
64	5320	39.40	Pass
100	5500	36.16	Pass
116	5580	37.37	Pass
140	5700	39.61	Pass

802.11n (20MHz)

Channel	Frequency (MHz)	26dBc Bandwidth (MHz)	Pass / Fail
36	5180	37.74	Pass
44	5220	39.20	Pass
48	5240	41.35	Pass
52	5260	38.29	Pass
60	5300	41.52	Pass
64	5320	38.19	Pass
100	5500	37.76	Pass
116	5580	39.43	Pass
140	5700	40.64	Pass

802.11n (40MHz)

Channel	Frequency (MHz)	26dBc Bandwidth (MHz)	Pass / Fail
38	5190	74.18	Pass
46	5230	73.79	Pass
54	5270	74.73	Pass
62	5310	75.15	Pass
102	5510	71.49	Pass
110	5550	71.14	Pass
134	5670	77.77	Pass

Spectrum Plot of Worst Value

802.11a

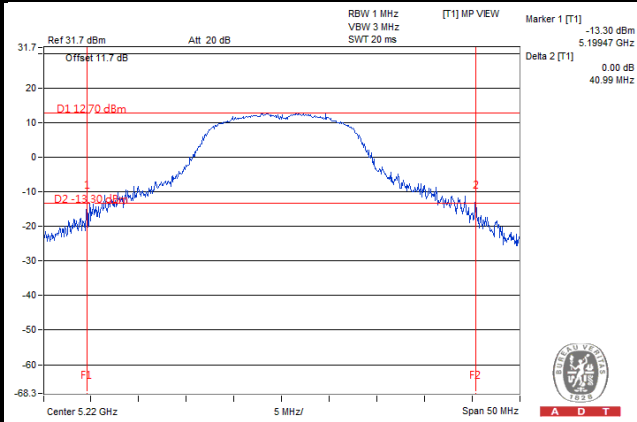

802.11n (20MHz)

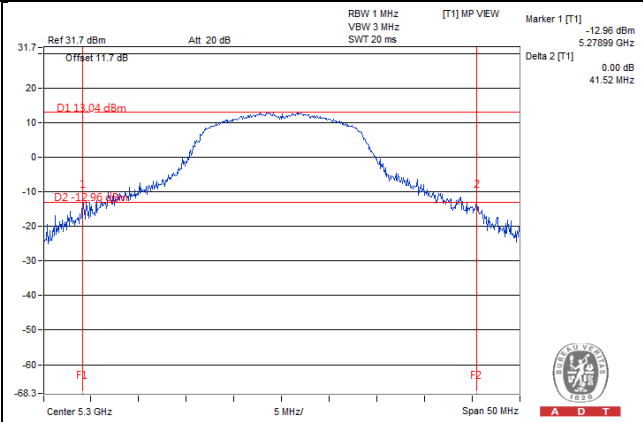

802.11n (40MHz)

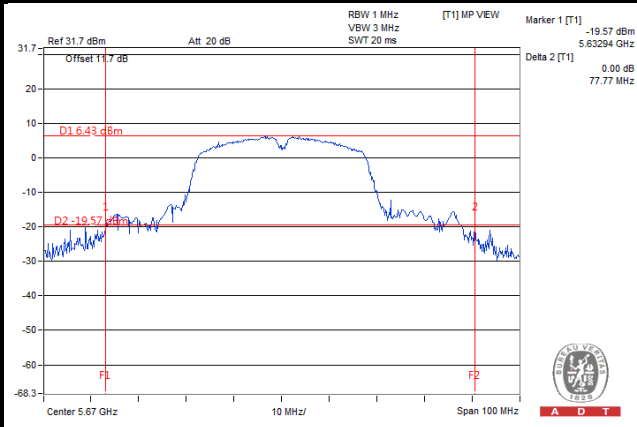

4.4 Peak Power Spectral Density Measurement

4.4.1 Limits of Peak Power Spectral Density Measurement

Operation Band	EUT Category		Limit
U-NII-1		Outdoor Access Point	17dBm/ MHz
		Fixed point-to-point Access Point	
		Indoor Access Point	
	√	Mobile and Portable client device	11dBm/ MHz
U-NII-2A	√		11dBm/ MHz
U-NII-2C	√		11dBm/ MHz
U-NII-3	√		30dBm/ 500MHz

4.4.2 Test Setup

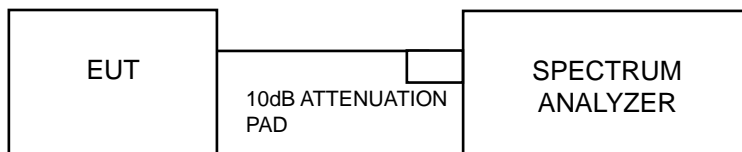

4.4.3 Test Instruments

Refer to section 4.1.3 to get information of above instrument.

4.4.4 Test Procedures

For U-NII-1, U-NII-2A, U-NII-2C band:

Using method SA-2

1. Set span to encompass the entire emission bandwidth (EBW) of the signal.
2. Set RBW = 1 MHz, Set VBW \geq 3 MHz, Detector = RMS
3. Sweep time = auto, trigger set to "free run".
4. Trace average at least 100 traces in power averaging mode.
5. Record the max value and add 10 log (1/duty cycle)

※For U-NII-3:

1. Set span to encompass the entire emission bandwidth (EBW) of the signal.
2. Set RBW = 300 kHz, Set VBW \geq 1 MHz, Detector = RMS
3. Use the peak marker function to determine the maximum power level in any 300 kHz band segment within the fundamental EBW.
4. Scale the observed power level to an equivalent value in 500 kHz by adjusting (reducing) the measured power by a bandwidth correction factor (BWCF) where $BWCF = 10\log(500\text{ kHz}/300\text{kHz})$
5. Sweep time = auto, trigger set to "free run".
6. Trace average at least 100 traces in power averaging mode.
7. Record the max value and add 10 log (1/duty cycle)

4.4.5 Deviation from Test Standard

No deviation.

4.4.6 EUT Operating Conditions

Same as Item 4.3.6.

4.4.7 Test Results

802.11a

Channel	Frequency (MHz)	PSD w/o Duty Factor (dBm)	Duty Factor	PSD with Duty Factor (dBm)	Maximum Limit (dBm)	Pass / Fail
36	5180	2.43	0.82	3.25	17	Pass
44	5220	3.52	0.82	4.34	17	Pass
48	5240	3.45	0.82	4.27	17	Pass
52	5260	3.42	0.82	4.24	11	Pass
60	5300	3.69	0.82	4.51	11	Pass
64	5320	3.60	0.82	4.42	11	Pass
100	5500	3.22	0.82	4.04	11	Pass
116	5580	2.67	0.82	3.49	11	Pass
140	5700	1.33	0.82	2.15	11	Pass

NOTE: Refer to section 3.3 for duty cycle spectrum plot.

802.11n (20MHz)

Channel	Frequency (MHz)	PSD w/o Duty Factor (dBm)	Duty Factor	PSD with Duty Factor (dBm)	Maximum Limit (dBm)	Pass / Fail
36	5180	3.18	0.87	4.05	17	Pass
44	5220	3.27	0.87	4.14	17	Pass
48	5240	3.21	0.87	4.08	17	Pass
52	5260	3.20	0.87	4.07	11	Pass
60	5300	3.50	0.87	4.37	11	Pass
64	5320	3.31	0.87	4.18	11	Pass
100	5500	2.93	0.87	3.80	11	Pass
116	5580	2.56	0.87	3.43	11	Pass
140	5700	1.63	0.87	2.50	11	Pass

NOTE: Refer to section 3.3 for duty cycle spectrum plot.

802.11n (40MHz)

Channel	Frequency (MHz)	PSD w/o Duty Factor (dBm)	Duty Factor	PSD with Duty Factor (dBm)	Maximum Limit (dBm)	Pass / Fail
38	5190	-2.87	1.75	-1.12	17	Pass
46	5230	-2.43	1.75	-0.68	17	Pass
54	5270	-1.82	1.75	-0.07	11	Pass
62	5310	-1.88	1.75	-0.13	11	Pass
102	5510	-3.06	1.75	-1.31	11	Pass
110	5550	-3.12	1.75	-1.37	11	Pass
134	5670	-4.01	1.75	-2.26	11	Pass

NOTE: Refer to section 3.3 for duty cycle spectrum plot.

Spectrum Plot of Worst Value

802.11a

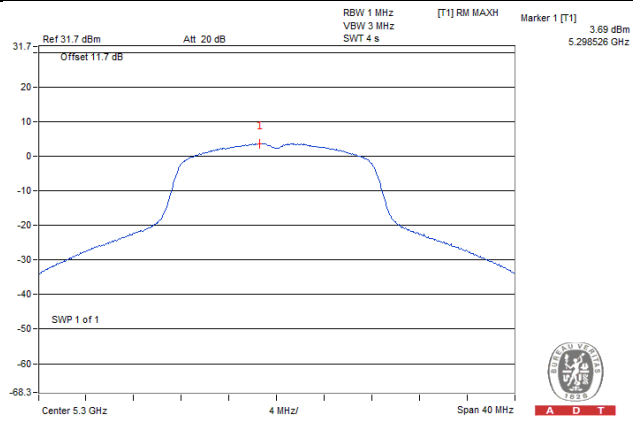

802.11n (20MHz)

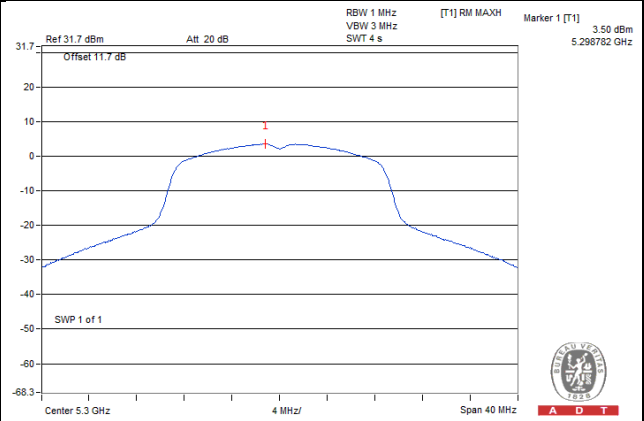

802.11n (40MHz)

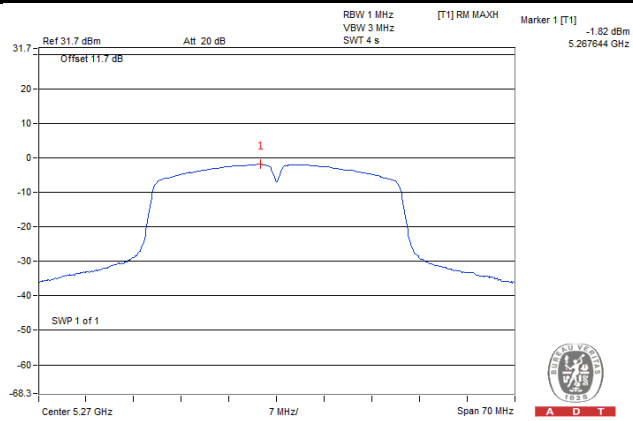

For U-NII-3 Band

802.11a

Channel	Frequency (MHz)	PSD w/o Duty Factor (dBm)	Duty Factor	PSD with Duty Factor (dBm)	Limit (dBm/500kHz)	Pass / Fail
149	5745	-1.67	0.82	-0.85	30	Pass
157	5785	-1.72	0.82	-0.90	30	Pass
165	5825	-1.26	0.82	-0.44	30	Pass

802.11n (20MHz)

Channel	Frequency (MHz)	PSD w/o Duty Factor (dBm)	Duty Factor	PSD with Duty Factor (dBm)	Limit (dBm/500kHz)	Pass / Fail
149	5745	-1.60	0.87	-0.73	30	Pass
157	5785	-2.25	0.87	-1.38	30	Pass
165	5825	-1.42	0.87	-0.55	30	Pass

802.11n (40MHz)

Channel	Frequency (MHz)	PSD w/o Duty Factor (dBm)	Duty Factor	PSD with Duty Factor (dBm)	Limit (dBm/500kHz)	Pass / Fail
151	5755	-7.79	1.75	-6.04	30	Pass
159	5795	-7.97	1.75	-6.22	30	Pass

Spectrum Plot of Worst Value

802.11a

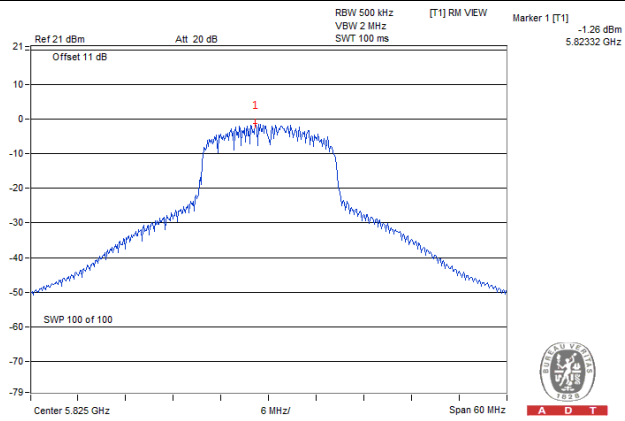

802.11n (20MHz)

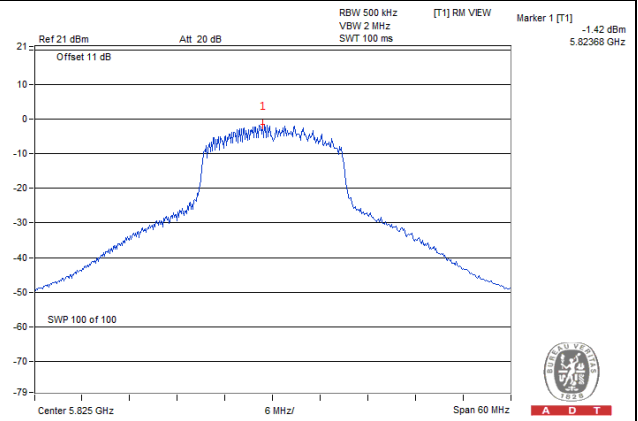

802.11n (40MHz)

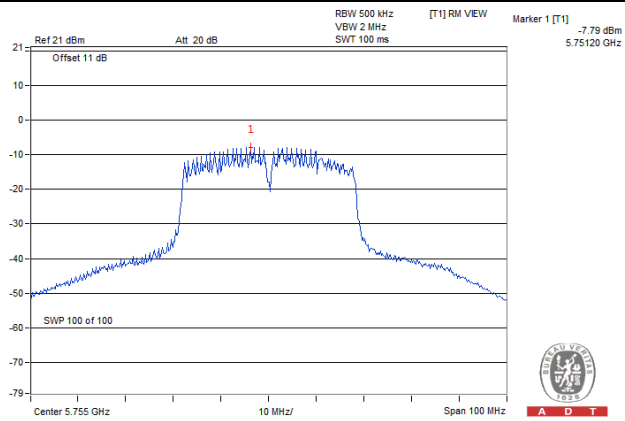

4.5 Frequency Stability

4.5.1 Limit of Frequency Stability Measurement

The frequency of the carrier signal shall be maintained within band of operation

4.5.2 Test Setup

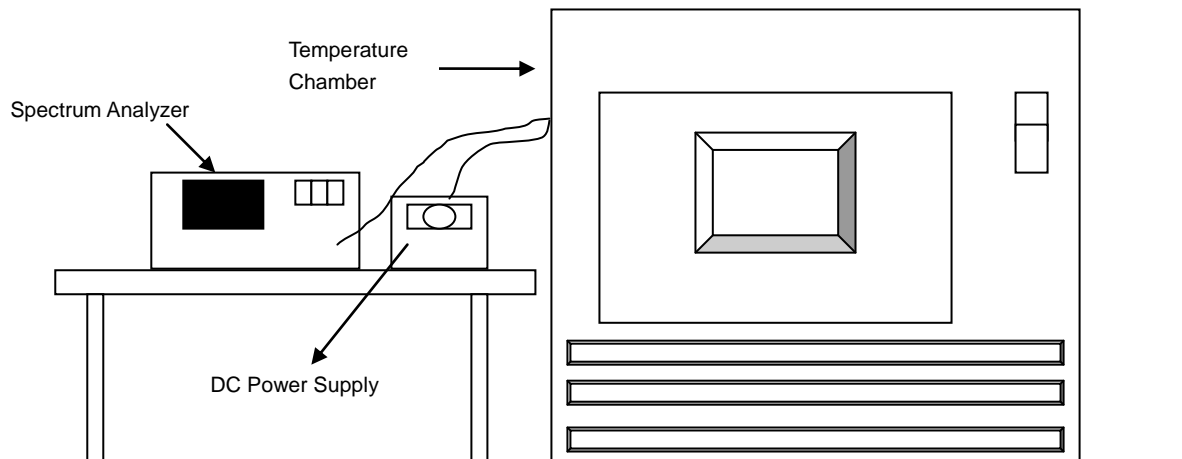

4.5.3 Test Instruments

Refer to section 4.1.3 to get information of above instrument.

4.5.4 Test Procedure

- a. To ensure emission at the band edge is maintained within the authorized band, those values shall be measured by radiation emissions at upper and lower frequency points, and finally compensated by frequency deviation as procedures below.
- b. The EUT was operated at the maximum output power, and connected to the spectrum analyzer, which is set to maximum hold function and peak detector. The peak value of the power envelope was measured and noted. The upper and lower frequency points were respectively measured relatively 10dB lower than the measured peak value.
- c. The frequency deviation was calculated by adding the upper frequency point and the lower frequency point divided by two. Those detailed values of frequency deviation are provided in table below.

4.5.5 Deviation from Test Standard

No deviation.

4.5.6 EUT Operating Condition

Set the EUT transmit at un-modulation mode to test frequency stability.

4.5.7 Test Results

Frequency Stability Versus Temp.									
Operating Frequency: 5320MHz									
Temp. (°C)	Power Supply (Vdc)	0 Minute		2 Minute		5 Minute		10 Minute	
		Measured Frequency (MHz)	Frequency Drift (%)	Measured Frequency (MHz)	Frequency Drift (%)	Measured Frequency (MHz)	Frequency Drift (%)	Measured Frequency (MHz)	Frequency Drift (%)
50	3.7	5320.015864	2.982	5320.016231	3.051	5320.016006	3.009	5320.015861	2.981
40	3.7	5320.015742	2.959	5320.015873	2.984	5320.016190	3.043	5320.016164	3.038
30	3.7	5320.017130	3.220	5320.017606	3.309	5320.017409	3.272	5320.016903	3.177
20	3.7	5320.018269	3.434	5320.018037	3.390	5320.018265	3.433	5320.018728	3.520
10	3.7	5320.019743	3.711	5320.019656	3.695	5320.019909	3.742	5320.020207	3.798
0	3.7	5320.017900	3.365	5320.018135	3.409	5320.017939	3.372	5320.018383	3.455
-10	3.7	5320.016533	3.108	5320.016563	3.113	5320.016919	3.180	5320.016781	3.154
-20	3.7	5320.015957	2.999	5320.016147	3.035	5320.016302	3.064	5320.015826	2.975
-30	3.7	5320.014836	2.789	5320.015230	2.863	5320.015262	2.869	5320.015359	2.887

Frequency Stability Versus Temp.									
Operating Frequency: 5320MHz									
Temp. (°C)	Power Supply (Vdc)	0 Minute		2 Minute		5 Minute		10 Minute	
		Measured Frequency (MHz)	Frequency Drift (%)	Measured Frequency (MHz)	Frequency Drift (%)	Measured Frequency (MHz)	Frequency Drift (%)	Measured Frequency (MHz)	Frequency Drift (%)
20	3.33	5320.017492	3.288	5320.017560	3.301	5320.017457	3.281	5320.017743	3.335
	3.7	5320.018269	3.434	5320.018037	3.390	5320.018265	3.433	5320.018728	3.520
	4.2	5320.019064	3.583	5320.018730	3.521	5320.018925	3.557	5320.019441	3.654

4.6 6dB Bandwidth Measurement

4.6.1 Limits of 6dB Bandwidth Measurement

The minimum of 6dB Bandwidth Measurement is 0.5MHz.

4.6.2 Test Setup

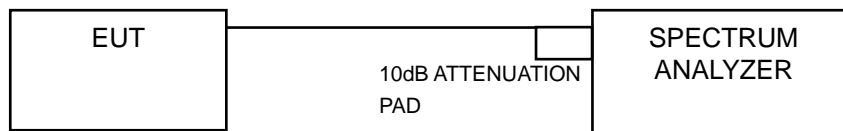

4.6.3 Test Instruments

Refer to section 4.1.3 to get information of above instrument.

4.6.4 Test Procedure

MEASUREMENT PROCEDURE REF

- Set resolution bandwidth (RBW) = 100kHz
- Set the video bandwidth (VBW) $\geq 3 \times$ RBW, Detector = Peak.
- Trace mode = max hold.
- Sweep = auto couple.
- Measure the maximum width of the emission that is constrained by the frequencies associated with the two amplitude points (upper and lower) that are attenuated by 6 dB relative to the maximum level measured in the fundamental emission

4.6.5 Deviation from Test Standard

No deviation.

4.6.6 EUT Operating Condition

The software provided by client to enable the EUT under transmission condition continuously at lowest, middle and highest channel frequencies individually.

4.6.7 Test Results

802.11a

Channel	Frequency (MHz)	6dB Bandwidth (MHz)	Minimum Limit (MHz)	Pass / Fail
149	5745	15.12	0.5	Pass
157	5785	15.13	0.5	Pass
165	5825	15.11	0.5	Pass

802.11n (20MHz)

Channel	Frequency (MHz)	6dB Bandwidth (MHz)	Minimum Limit (MHz)	Pass / Fail
149	5745	15.16	0.5	Pass
157	5785	15.12	0.5	Pass
165	5825	15.15	0.5	Pass

802.11n (40MHz)

Channel	Frequency (MHz)	6dB Bandwidth (MHz)	Minimum Limit (MHz)	Pass / Fail
151	5755	35.15	0.5	Pass
159	5795	33.93	0.5	Pass

Spectrum Plot of Worst Value

802.11a

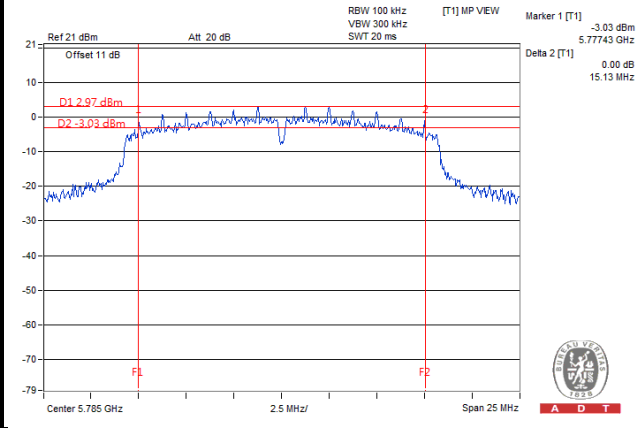

802.11n (20MHz)

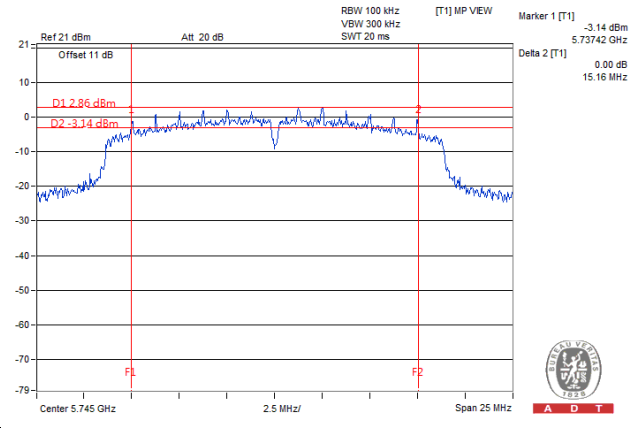

802.11n (40MHz)

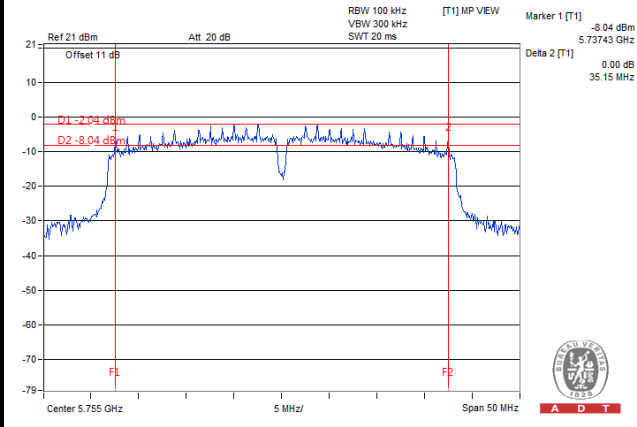

5 Pictures of Test Arrangements

Please refer to the attached file (Test Setup Photo).



A D T

Appendix – Information on the Testing Laboratories

We, Bureau Veritas Consumer Products Services (H.K.) Ltd., Taoyuan Branch, were founded in 1988 to provide our best service in EMC, Radio, Telecom and Safety consultation. Our laboratories are accredited and approved according to ISO/IEC 17025.

If you have any comments, please feel free to contact us at the following:

Linko EMC/RF Lab

Tel: 886-2-26052180

Fax: 886-2-26051924

Hsin Chu EMC/RF Lab/Telecom Lab

Tel: 886-3-5935343

Fax: 886-3-5935342

Hwa Ya EMC/RF/Safety

Tel: 886-3-3183232

Fax: 886-3-3270892

Email: service.adt@tw.bureauveritas.com**Web Site:** www.bureauveritas-adt.com

The address and road map of all our labs can be found in our web site also.

--- END ---