



# FCC RF Test Report

**APPLICANT** : MITAC International Corp  
**EQUIPMENT** : Tablet  
**BRAND NAME** : Mio, Mitac, Stryker  
**MODEL NAME** : N450(Device);N450 Cradle;N527(Battery Hold)  
**FCC ID** : P4Q-N450W  
**STANDARD** : FCC Part 15 Subpart C §15.247  
**CLASSIFICATION** : (DTS) Digital Transmission System

The product was received on Dec. 25, 2015 and testing was completed on Jan. 20, 2016. We, SPORTON INTERNATIONAL INC., would like to declare that the tested sample has been evaluated in accordance with the test procedures and has been in compliance with the applicable technical standards.

The test results in this report apply exclusively to the tested model / sample. Without written approval of SPORTON INTERNATIONAL INC., the test report shall not be reproduced except in full.

Reviewed by: Joseph Lin / Supervisor

Approved by: Jones Tsai / Manager



## **SPORTON INTERNATIONAL INC.**

**No. 52, Hwa Ya 1<sup>st</sup> Rd., Hwa Ya Technology Park, Kwei-Shan District, Tao Yuan City, Taiwan, R.O.C.**



# TABLE OF CONTENTS

**SUMMARY OF TEST RESULT ..... 4**

**1 GENERAL DESCRIPTION..... 5**

1.1 Applicant ..... 5

1.2 Manufacturer..... 5

1.3 Product Feature of Equipment Under Test..... 5

1.4 Product Specification of Equipment Under Test..... 5

1.5 Modification of EUT ..... 5

1.6 Testing Location ..... 6

1.7 Applicable Standards..... 6

**2 TEST CONFIGURATION OF EQUIPMENT UNDER TEST..... 7**

2.1 Descriptions of Test Mode ..... 7

2.2 Test Mode..... 8

2.3 Connection Diagram of Test System..... 9

2.4 Support Unit used in test configuration and system ..... 10

2.5 EUT Operation Test Setup ..... 10

2.6 Measurement Results Explanation Example..... 11

**3 TEST RESULT ..... 12**

3.1 6dB and 99% Bandwidth Measurement ..... 12

3.2 Peak Output Power Measurement ..... 17

3.3 Power Spectral Density Measurement ..... 18

3.4 Conducted Band Edges and Spurious Emission Measurement ..... 23

3.5 Radiated Band Edges and Spurious Emission Measurement ..... 32

3.6 AC Conducted Emission Measurement..... 37

3.7 Antenna Requirements ..... 41

**4 LIST OF MEASURING EQUIPMENT..... 42**

**5 UNCERTAINTY OF EVALUATION..... 44**

**APPENDIX A. CONDUCTED TEST RESULTS**

**APPENDIX B RADIATED TEST RESULTS**

**APPENDIX C RADIATED SPURIOUS EMISSION PLOTS**

**APPENDIX D SETUP PHOTOGRAPHS**



### REVISION HISTORY

REPORT NO.	VERSION	DESCRIPTION	ISSUED DATE
FR5D2503B	Rev. 01	Initial issue of report	Feb. 25, 2016



### SUMMARY OF TEST RESULT

Report Section	FCC Rule	Description	Limit	Result	Remark
3.1	15.247(a)(2)	6dB Bandwidth	$\geq 0.5\text{MHz}$	Pass	-
3.1	-	99% Bandwidth	-	Pass	-
3.2	15.247(b)(1)	Peak Output Power	$\leq 30\text{dBm}$	Pass	-
3.3	15.247(e)	Power Spectral Density	$\leq 8\text{dBm}/3\text{kHz}$	Pass	-
3.4	15.247(d)	Conducted Band Edges and Spurious Emission	$\leq 20\text{dBc}$	Pass	-
3.5	15.247(d)	Radiated Band Edges and Spurious Emission	15.209(a) & 15.247(d)	Pass	Under limit 7.57 dB at 47.82 MHz
3.6	15.207	AC Conducted Emission	15.207(a)	Pass	Under limit 7.00 dB at 0.454 MHz
3.7	15.203 & 15.247(b)	Antenna Requirement	N/A	Pass	-



# 1 General Description

## 1.1 Applicant

**MITAC International Corp**

Building B, No. 209, Sec.1, Nan Gang Rd., Nan Gang Dist., Taipei City 11568, Taiwan, R.O.C.

## 1.2 Manufacturer

**MITAC Computer (Kunshan) Co., Ltd.**

No. 269, 2nd Avenue, District A, Comprehensive Free Trade Zone, 300 Kunshan, China

## 1.3 Product Feature of Equipment Under Test

Product Feature	
Equipment	Tablet
Brand Name	Mio, Mitac, Stryker
Model Name	N450(Device);N450 Cradle;N527(Battery Hold)
FCC ID	P4Q-N450W
EUT supports Radios application	NFC WLAN 11a/b/g/n HT20/HT40 Bluetooth v4.0 EDR/LE
EUT Stage	Production Unit

**Remark:** The above EUT's information was declared by manufacturer. Please refer to the specifications or user's manual for more detailed description.

## 1.4 Product Specification of Equipment Under Test

Standards-related Product Specification	
Tx/Rx Frequency Range	2402 MHz ~ 2480 MHz
Number of Channels	40
Carrier Frequency of Each Channel	40 Channel(37 hopping + 3 advertising channel)
Maximum Output Power to Antenna	2.67 dBm (0.0018 W)
99% Occupied Bandwidth	1.04MHz
Antenna Type	PIFA Antenna type with gain 2.30 dBi
Type of Modulation	Bluetooth LE : GFSK

## 1.5 Modification of EUT

No modifications are made to the EUT during all test items.



### 1.6 Testing Location

Sporton Lab is accredited to ISO 17025 by Taiwan Accreditation Foundation (TAF code : 1190) and the FCC designation No. TW1022 under the FCC 2.948(e) by Mutual Recognition Agreement (MRA) in FCC Test.

<b>Test Site</b>	SPORTON INTERNATIONAL INC.		
<b>Test Site Location</b>	No. 52, Hwa Ya 1 <sup>st</sup> Rd., Hwa Ya Technology Park, Kwei-Shan District, Tao Yuan City, Taiwan, R.O.C. TEL: +886-3-327-3456 FAX: +886-3-328-4978		
<b>Test Site No.</b>	<b>Sporton Site No.</b>		
	TH05-HY	CO05-HY	03CH07-HY

**Note:** The test site complies with ANSI C63.4 2014 requirement.

### 1.7 Applicable Standards

According to the specifications of the manufacturer, the EUT must comply with the requirements of the following standards:

- ♦ FCC Part 15 Subpart C §15.247
- ♦ FCC KDB Publication No. 558074 D01 DTS Meas. Guidance v03r03
- ♦ ANSI C63.10-2013

**Remark:**

1. All test items were verified and recorded according to the standards and without any deviation during the test.
2. This EUT has also been tested and complied with the requirements of FCC Part 15, Subpart B, recorded in a separate test report.



## 2 Test Configuration of Equipment Under Test

### 2.1 Descriptions of Test Mode

The RF output power was recorded in the following table:

Channel	Frequency	Bluetooth 4.0 – LE RF Output Power	
		Data Rate / Modulation	
		GFSK	
		1Mbps	
Ch00	2402MHz	1.39 dBm	
Ch19	2440MHz	1.65 dBm	
Ch39	2480MHz	2.67 dBm	

- a. The EUT has been associated with peripherals and configuration operated in a manner tended to maximize its emission characteristics in a typical application. Frequency range investigated: conduction (150 kHz to 30 MHz), radiation (9 kHz to the 10th harmonic of the highest fundamental frequency or to 40 GHz, whichever is lower). Pre-scanned tests, X, Y, Z in three orthogonal panels to determine the final configuration (Z plane as worst plane) from all possible combinations.
  
- b. AC power line Conducted Emission was tested under maximum output power.



## 2.2 Test Mode

The following summary table is showing all test modes to demonstrate in compliance with the standard.

Summary table of Test Cases	
Test Item	Data Rate / Modulation
	Bluetooth 4.0 – LE / GFSK
Conducted TCs	Mode 1: Bluetooth Tx CH00_2402 MHz_1Mbps Mode 2: Bluetooth Tx CH19_2440 MHz_1Mbps Mode 3: Bluetooth Tx CH39_2480 MHz_1Mbps
Radiated TCs	Mode 1: Bluetooth Tx CH00_2402 MHz_1Mbps Mode 2: Bluetooth Tx CH19_2440 MHz_1Mbps Mode 3: Bluetooth Tx CH39_2480 MHz_1Mbps
AC Conducted Emission	Mode 1: WLAN (2.4GHz) Link + Bluetooth Link + Camera (Rear) + USB HDD + Adapter + Micro SD + Micro USB Cable ( Data Link with Notebook) + Battery + Earphone



## 2.3 Connection Diagram of Test System

<Bluetooth 4.0 – LE Tx Mode>

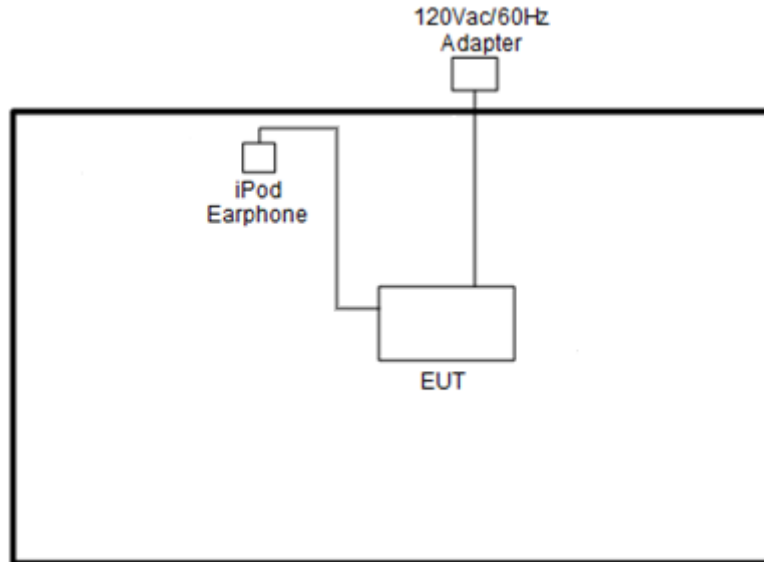

<AC Conducted Emission Mode>

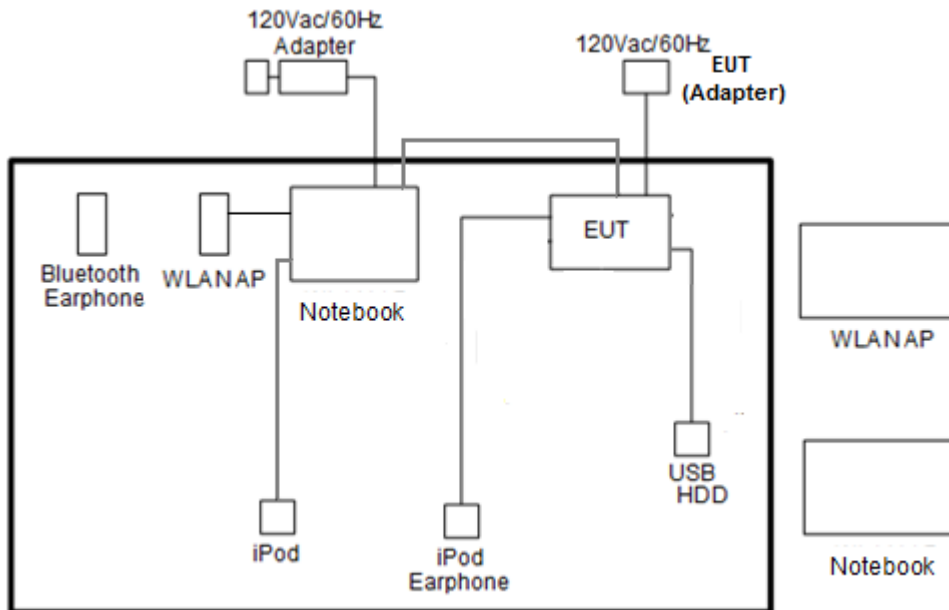



## 2.4 Support Unit used in test configuration and system

Item	Equipment	Trade Name	Model Name	FCC ID	Data Cable	Power Cord
1.	WLAN AP	D-Link	DIR-865L	KA2IR865LA1	N/A	Unshielded, 1.8 m
2.	Notebook	DELL	Latitude E6320	FCC DoC/ Contains FCC ID: QDS-BRCM1054	N/A	AC I/P: Unshielded, 1.2 m DC O/P: Shielded, 1.8 m
3.	Notebook	DELL	P20G	FCC DoC/ Contains FCC ID: QDS-BRCM1051	N/A	AC I/P: Unshielded, 1.2 m DC O/P: Shielded, 1.8 m
4.	Bluetooth Earphone	Sony Ericsson	MW600	PY7DDA-2029	N/A	N/A
5.	iPod	Apple	A1285	FCC DoC	Shielded, 1.0 m	N/A
6.	iPod Earphone	Apple	N/A	Verification	Unshielded, 1.0 m	N/A
7.	USB HDD	PQI	H568V	FCC DoC	Shielded, 0.45 m	N/A
8.	SD Card	SanDisk	MicroSD HC	FCC DoC	N/A	N/A

## 2.5 EUT Operation Test Setup

For Bluetooth function, programmed RF utility, “Putty” installed in the notebook make the EUT provide functions like channel selection and power level for continuous transmitting and receiving signals.



## 2.6 Measurement Results Explanation Example

For all conducted test items:

The offset level is set in the spectrum analyzer to compensate the RF cable loss and attenuator factor between EUT conducted output port and spectrum analyzer. With the offset compensation, the spectrum analyzer reading level is exactly the EUT RF output level.

Example :

The spectrum analyzer offset is derived from RF cable loss and attenuator factor.

*Offset = RF cable loss + attenuator factor.*

Following shows an offset computation example with cable loss 4.2 dB and 10dB attenuator.

$$\begin{aligned} \text{Offset(dB)} &= \text{RF cable loss(dB)} + \text{attenuator factor(dB)}. \\ &= 4.2 + 10 = 14.2 \text{ (dB)} \end{aligned}$$

### 3 Test Result

#### 3.1 6dB and 99% Bandwidth Measurement

##### 3.1.1 Limit of 6dB and 99% Bandwidth

The minimum 6 dB bandwidth shall be at least 500 kHz.

##### 3.1.2 Measuring Instruments

The section 4.0 of List of Measuring Equipment of this test report is used for test.

##### 3.1.3 Test Procedures

1. The testing follows FCC KDB Publication No. 558074 D01 DTS Meas. Guidance v03r03.
2. The RF output of EUT was connected to the spectrum analyzer by RF cable and attenuator. The path loss was compensated to the results for each measurement.
3. Set to the maximum power setting and enable the EUT transmit continuously.
4. Make the measurement with the spectrum analyzer's resolution bandwidth (RBW) = 100 kHz. Set the Video bandwidth (VBW) = 300 kHz. In order to make an accurate measurement. The 6 dB bandwidth must be greater than 500 kHz.
5. For 99% Bandwidth Measurement, the spectrum analyzer's resolution bandwidth (RBW) is set 30kHz and set the Video bandwidth (VBW) = 100kHz.
6. Measure and record the results in the test report.

##### 3.1.4 Test Setup

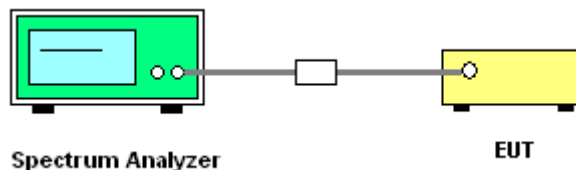



### 3.1.5 Test Result of 6dB Bandwidth

Test data refer to Appendix A.

6 dB Bandwidth Plot on Channel 00

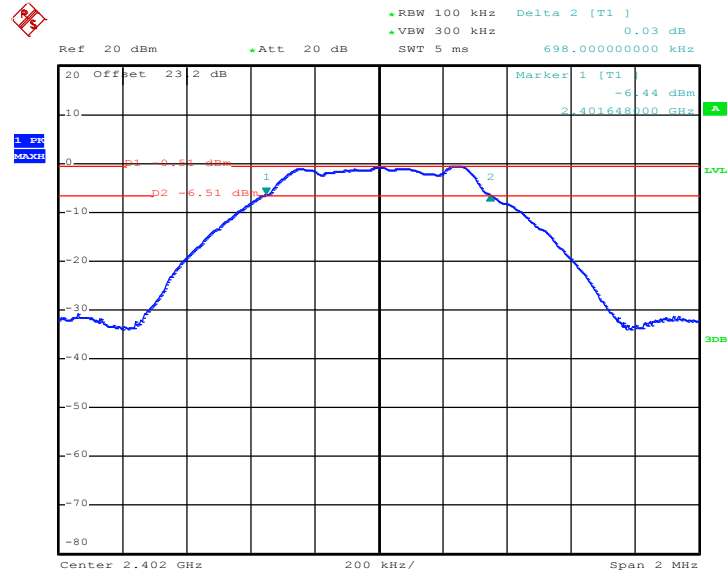

Date: 20.JAN.2016 14:25:39



6 dB Bandwidth Plot on Channel 19

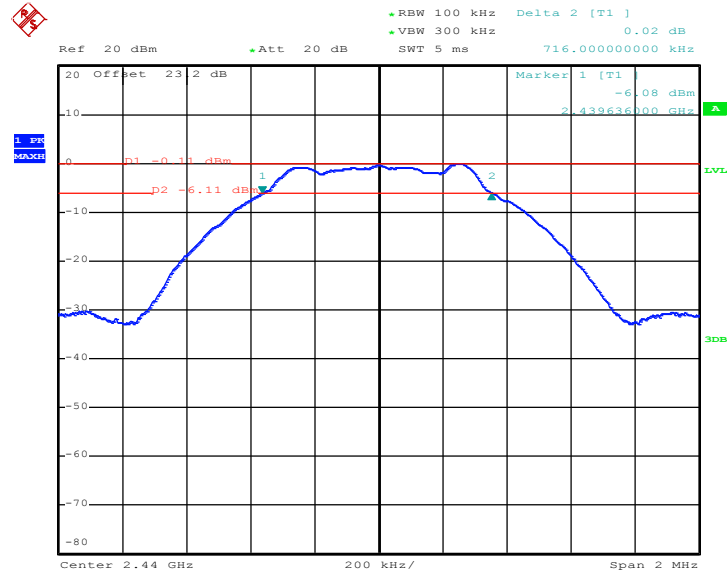

Date: 20.JAN.2016 14:22:23

6 dB Bandwidth Plot on Channel 39

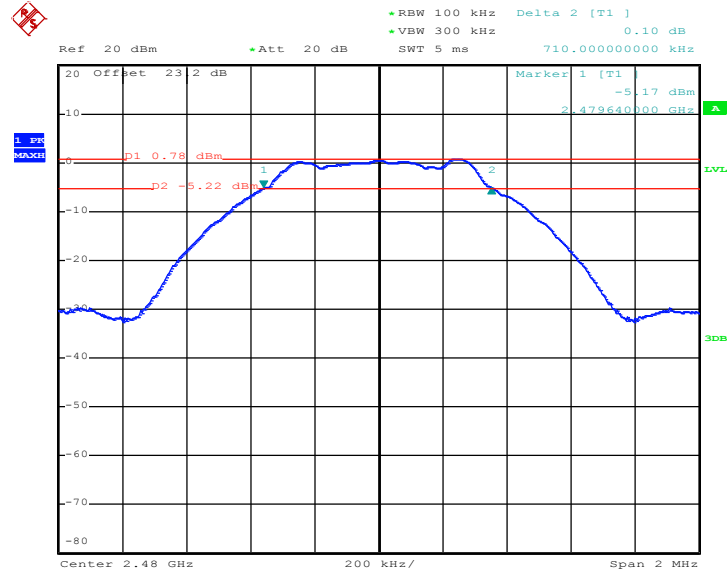

Date: 20.JAN.2016 14:34:27



### 3.1.6 Test Result of 99% Occupied Bandwidth

Test data refer to Appendix A.

99% Bandwidth Plot on Channel 00

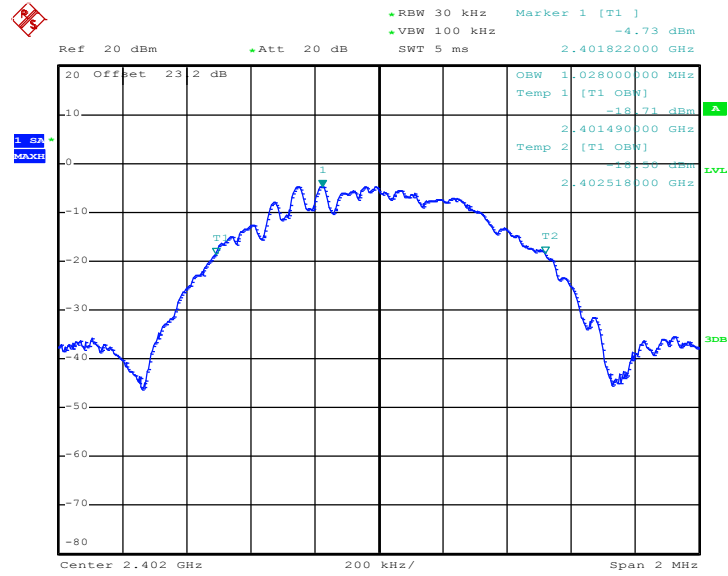

Date: 20.JAN.2016 14:26:06



99% Occupied Bandwidth Plot on Channel 19

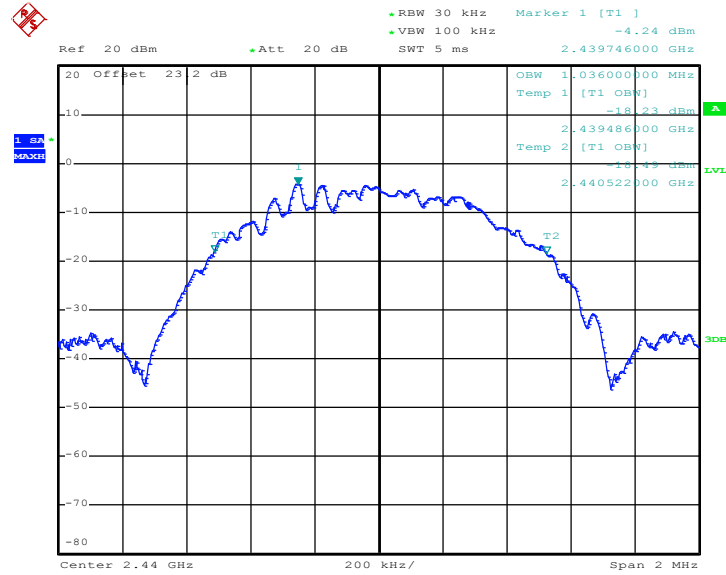

Date: 20.JAN.2016 14:22:59

99% Occupied Bandwidth Plot on Channel 39

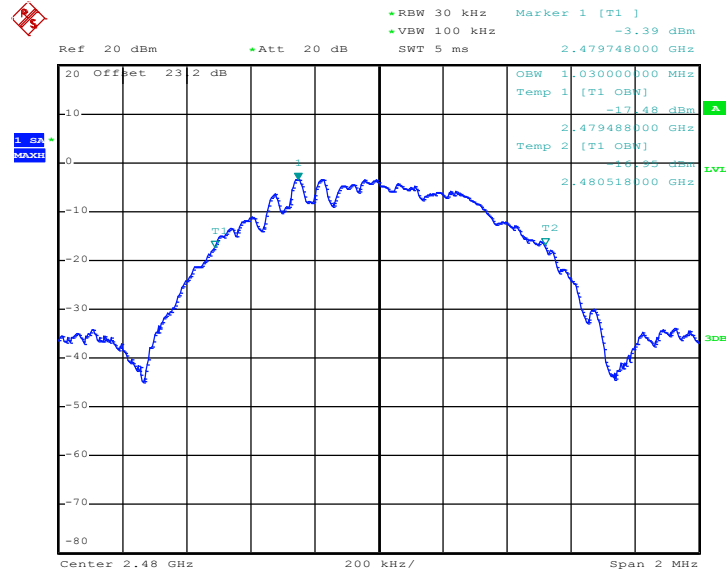

Date: 20.JAN.2016 14:34:51

Note: The occupied channel bandwidth is maintained within the band of operation for all of the modulations.



## 3.2 Peak Output Power Measurement

### 3.2.1 Limit of Peak Output Power

For systems using digital modulation in the 2400-2483.5MHz, the limit for peak output power is 30dBm. If transmitting antenna of directional gain greater than 6dBi is used, the peak output power from the intentional radiator shall be reduced below the above stated value by the amount in dB that the directional gain of the antenna exceeds 6 dBi. In case of point-to-point operation, the limit has to be reduced by 1dB for every 3dB that the directional gain of the antenna exceeds 6dBi.

### 3.2.2 Measuring Instruments

The section 4.0 of List of Measuring Equipment of this test report is used for test.

### 3.2.3 Test Procedures

1. The testing follows the Measurement Procedure of FCC KDB No. 558074 DTS D01 Meas. Guidance v03r03 section 9.1.2 PKPM1 Peak power meter method.
2. The RF output of EUT was connected to the power meter by RF cable and attenuator. The path loss was compensated to the results for each measurement.
3. Set to the maximum power setting and enable the EUT transmit continuously.
4. Measure the conducted output power and record the results in the test report.

### 3.2.4 Test Setup

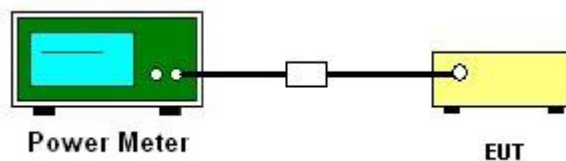

### 3.2.5 Test Result of Peak Output Power

Test data refers to Appendix A.

### 3.3 Power Spectral Density Measurement

#### 3.3.1 Limit of Power Spectral Density

The peak power spectral density shall not be greater than 8dBm in any 3kHz band at any time interval of continuous transmission.

#### 3.3.2 Measuring Instruments

The section 4.0 of List of Measuring Equipment of this test report is used for test.

#### 3.3.3 Test Procedures

1. The testing follows Measurement Procedure 10.2 Method PKPSD of FCC KDB Publication No. 558074 D01 DTS Meas. Guidance v03r03
2. The RF output of EUT was connected to the spectrum analyzer by RF cable and attenuator. The path loss was compensated to the results for each measurement.
3. Set to the maximum power setting and enable the EUT transmit continuously.
4. Make the measurement with the spectrum analyzer's resolution bandwidth (RBW) = 3 kHz. Video bandwidth VBW = 10 kHz In order to make an accurate measurement, set the span to 1.5 times DTS Channel Bandwidth. (6dB BW)
5. Detector = peak, Sweep time = auto couple, Trace mode = max hold, Allow trace to fully stabilize. Use the peak marker function to determine the maximum power level.
6. Measure and record the results in the test report.
7. The Measured power density (dBm)/ 100kHz is a reference level and used as 20dBc down limit line for Conducted Band Edges and Conducted Spurious Emission.

#### 3.3.4 Test Setup

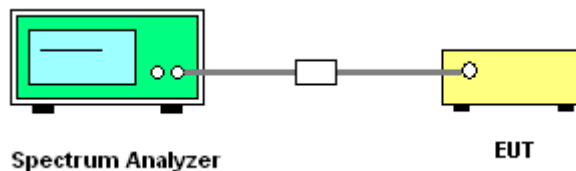



### 3.3.5 Test Result of Power Spectral Density

Test data refers to Appendix A.

### 3.3.6 Test Result of Power Spectral Density Plots (100kHz)

PSD 100kHz Plot on Channel 00

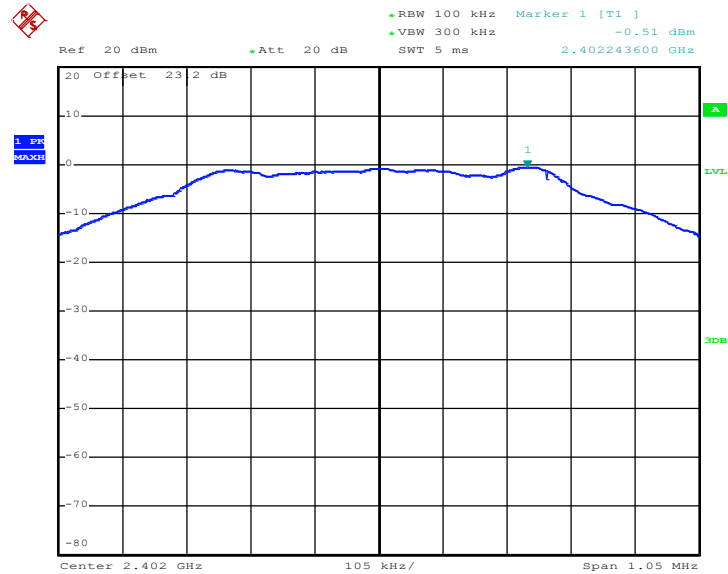

Date: 20.JAN.2016 14:27:01



PSD 100kHz Plot on Channel 19

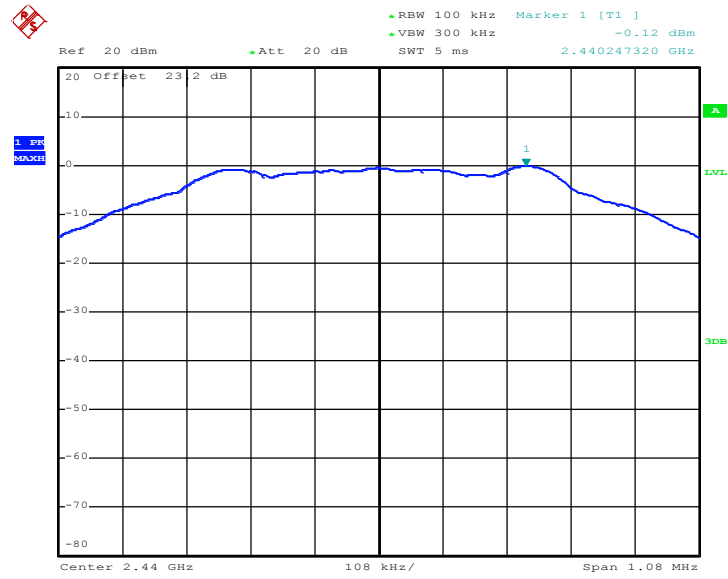

Date: 20.JAN.2016 14:23:42

PSD 100kHz Plot on Channel 39

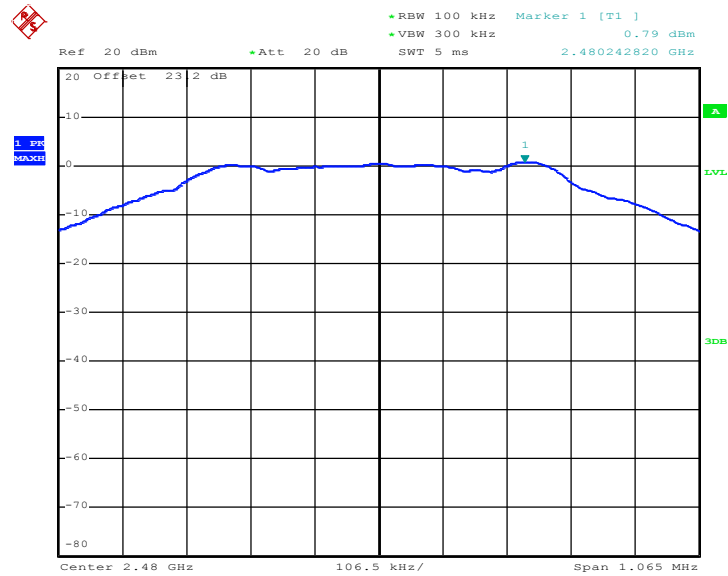

Date: 20.JAN.2016 14:36:25



### 3.3.7 Test Result of Power Spectral Density Plots (3kHz)

PSD 3kHz Plot on Channel 00

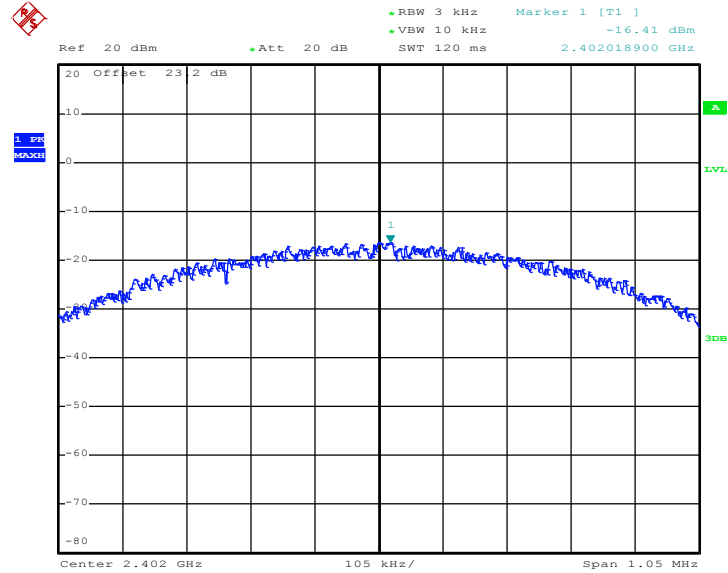

Date: 20.JAN.2016 14:26:38



PSD 3kHz Plot on Channel 19

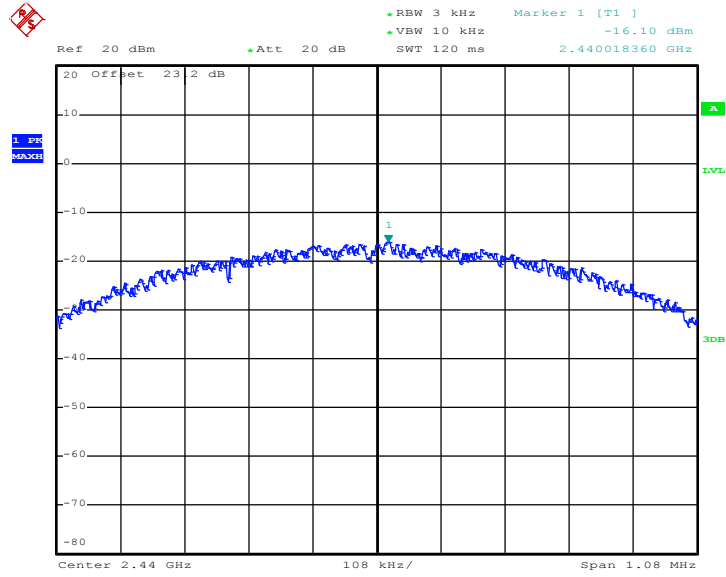

Date: 20.JAN.2016 14:23:18

PSD 3kHz Plot on Channel 39

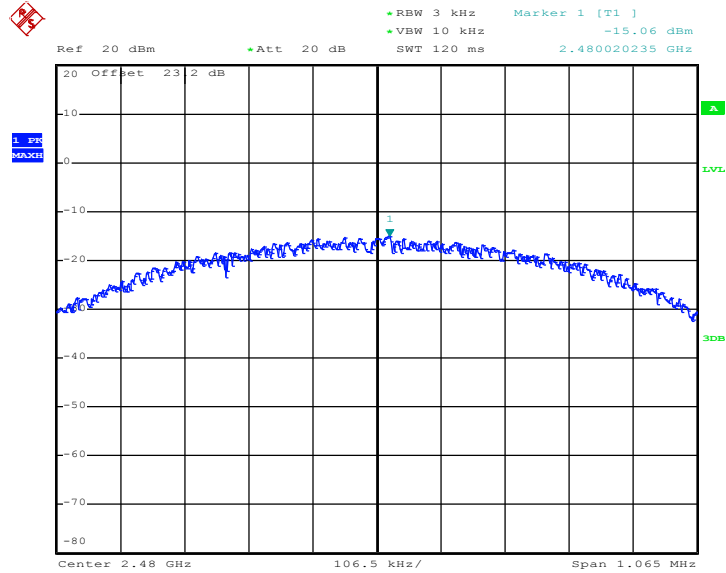

Date: 20.JAN.2016 14:35:39

## 3.4 Conducted Band Edges and Spurious Emission Measurement

### 3.4.1 Limit of Conducted Band Edges and Spurious Emission

All harmonics/spurious must be at least 20 dB down from the highest emission level within the authorized band.

### 3.4.2 Measuring Instruments

The section 4.0 of List of Measuring Equipment of this test report is used for test.

### 3.4.3 Test Procedure

1. The testing follows FCC KDB Publication No. 558074 D01 DTS Meas. Guidance v03r03.
2. The RF output of EUT was connected to the spectrum analyzer by RF cable and attenuator. The path loss was compensated to the results for each measurement.
3. Set to the maximum power setting and enable the EUT transmit continuously.
4. Set RBW = 100 kHz, VBW=300 kHz, Peak Detector. Unwanted Emissions measured in any 100 kHz bandwidth outside of the authorized frequency band shall be attenuated by at least 20 dB relative to the maximum in-band peak PSD level in 100 kHz when maximum peak conducted output power procedure is used. If the transmitter complies with the conducted power limits based on the use of RMS averaging over a time interval, the attenuation required under this paragraph shall be 30 dB instead of 20 dB per 15.247(d).
5. Measure and record the results in the test report.
6. The RF fundamental frequency should be excluded against the limit line in the operating frequency band.

### 3.4.4 Test Setup









High Band Edge Plot on Channel 39

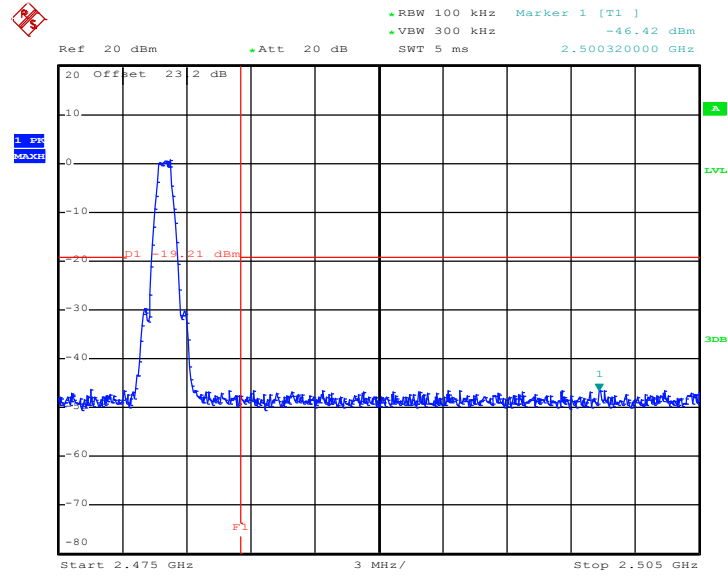

Date: 20.JAN.2016 14:37:17



### 3.4.6 Test Result of Conducted Spurious Emission Plots

#### Conducted Spurious Emission Plot on Bluetooth LE 1Mbps GFSK Channel 00

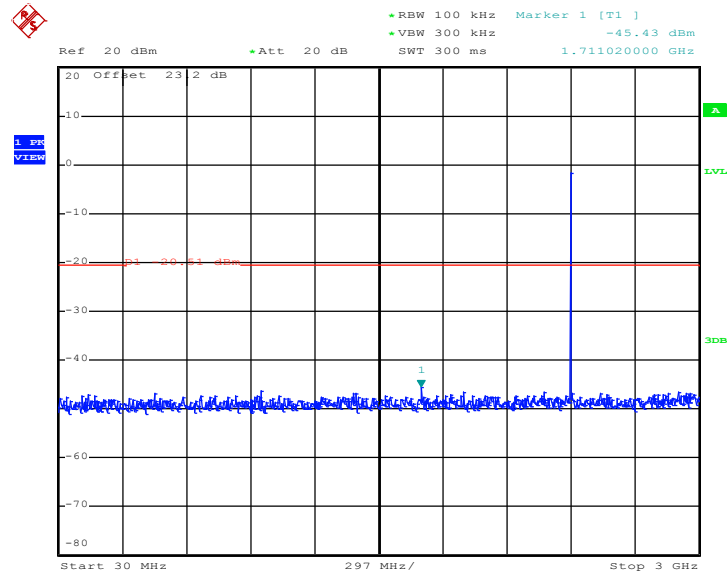

Date: 20.JAN.2016 14:32:01



Conducted Spurious Emission Plot on Bluetooth LE 1Mbps  
GFSK Channel 00

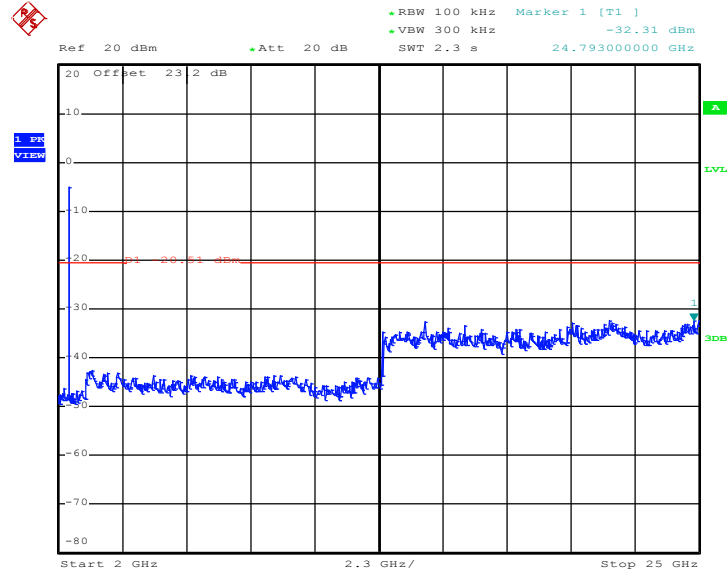

Date: 20.JAN.2016 14:32:09



Conducted Spurious Emission Plot on Bluetooth LE 1Mbps  
GFSK Channel 19

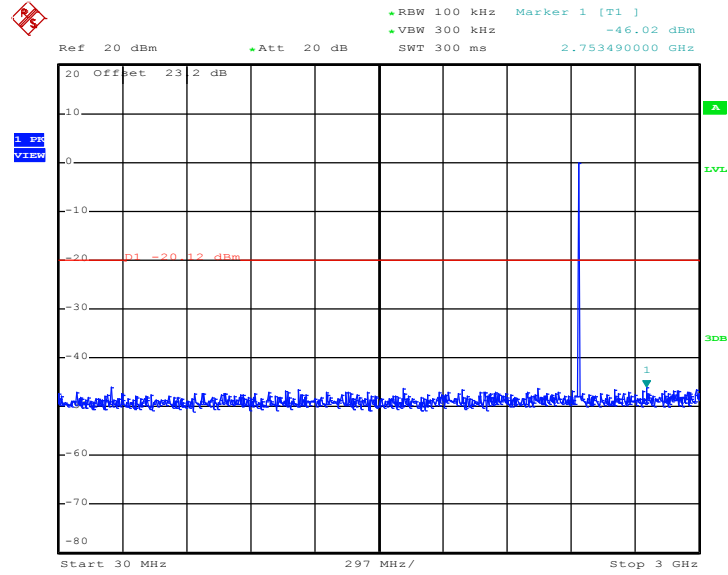

Date: 20.JAN.2016 14:32:46



Conducted Spurious Emission Plot on Bluetooth LE 1Mbps  
GFSK Channel 19

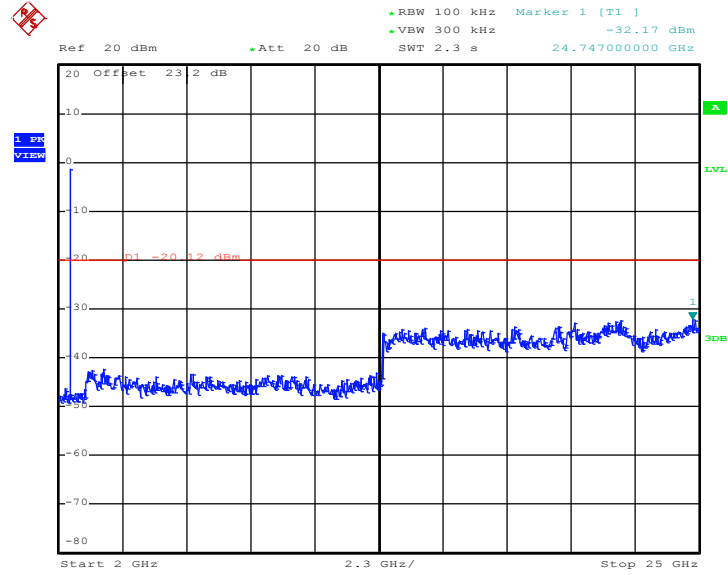

Date: 20.JAN.2016 14:32:55



Conducted Spurious Emission Plot on Bluetooth LE 1Mbps  
GFSK Channel 39

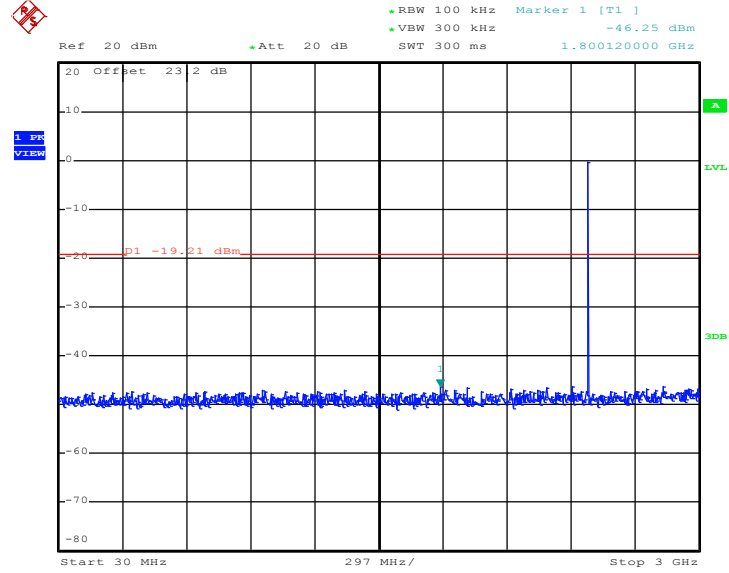

Date: 20.JAN.2016 14:37:41



Conducted Spurious Emission Plot on Bluetooth LE 1Mbps  
GFSK Channel 39

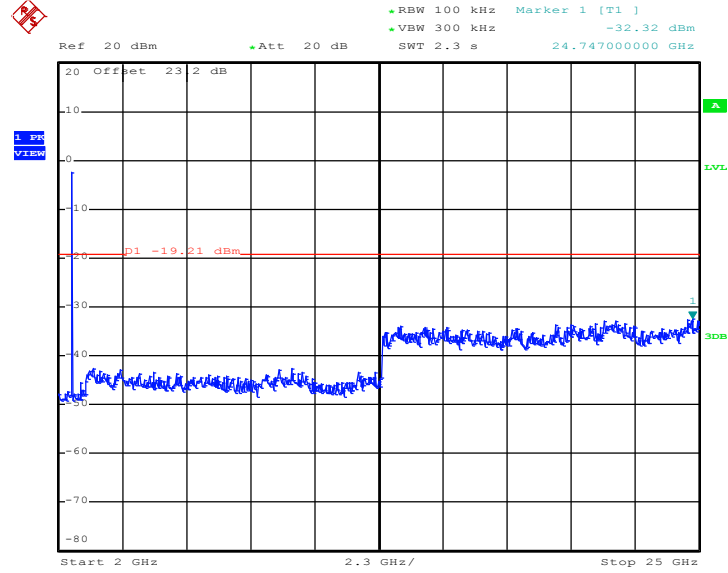

Date: 20.JAN.2016 14:37:50



### 3.5 Radiated Band Edges and Spurious Emission Measurement

#### 3.5.1 Limit of Radiated Band Edges and Spurious Emission

In any 100 kHz bandwidth outside the intentional radiator frequency band, all harmonics/spurious must be at least 20 dB below the highest emission level within the authorized band. If the output power of this device was measured by spectrum analyzer, the attenuation under this paragraph shall be 30 dB instead of 20 dB. In addition, radiated emissions which fall in the restricted bands must also comply with the FCC section 15.209 limits as below.

Frequency (MHz)	Field Strength (microvolts/meter)	Measurement Distance (meters)
0.009 – 0.490	2400/F(kHz)	300
0.490 – 1.705	24000/F(kHz)	30
1.705 – 30.0	30	30
30 – 88	100	3
88 – 216	150	3
216 - 960	200	3
Above 960	500	3

#### 3.5.2 Measuring Instruments

The section 4.0 of List of Measuring Equipment of this test report is used for test.





3.5.3 Test Procedures

1. The testing follows FCC KDB Publication No. 558074 D01 DTS Meas. Guidance v03r03.
2. The EUT was arranged to its worst case and then tune the antenna tower (from 1 m to 4 m) and turntable (from 0 degree to 360 degrees) to find the maximum reading. A pre-amp and a high pass filter are used for the test in order to get better signal level.
3. The EUT was placed on a turntable with 0.8 meter for frequency below 1GHz and 1.5 meter for frequency above 1GHz respectively above ground.
4. The EUT was set 3 meters from the interference receiving antenna, which was mounted on the top of a variable height antenna tower.
5. Corrected Reading: Antenna Factor + Cable Loss + Read Level - Preamp Factor = Level
6. For measurement below 1GHz, If the emission level of the EUT measured by the peak detector is 3 dB lower than the applicable limit, the peak emission level will be reported. Otherwise, the emission measurement will be repeated using the quasi-peak detector and reported.
7. Use the following spectrum analyzer settings:
  - (1) Span shall wide enough to fully capture the emission being measured;
  - (2) Set RBW=100 kHz for  $f < 1$  GHz;  $VBW \geq RBW$ ; Sweep = auto; Detector function = peak; Trace = max hold;
  - (3) Set RBW = 1 MHz, VBW= 3MHz for  $f \geq 1$  GHz for peak measurement.
 

For average measurement:

    - $VBW = 10$  Hz, when duty cycle is no less than 98 percent.
    - $VBW \geq 1/T$ , when duty cycle is less than 98 percent where T is the minimum transmission duration over which the transmitter is on and is transmitting at its maximum power control level for the tested mode of operation.

Band	Duty Cycle(%)	T(μs)	1/T(kHz)	VBW Setting
Bluetooth 4.0 - LE	100.00	-	-	10Hz

### 3.5.4 Test Setup

For radiated emissions below 30MHz

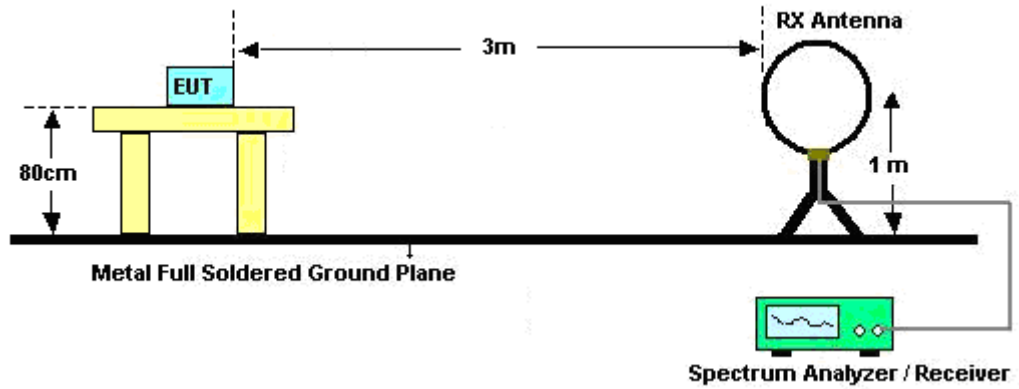

For radiated emissions from 30MHz to 1GHz

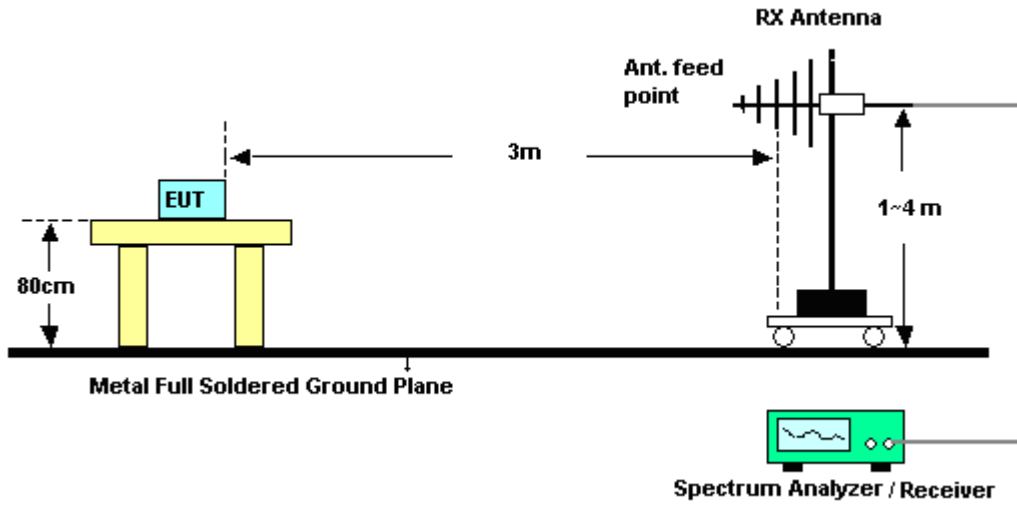

For radiated emissions above 1GHz

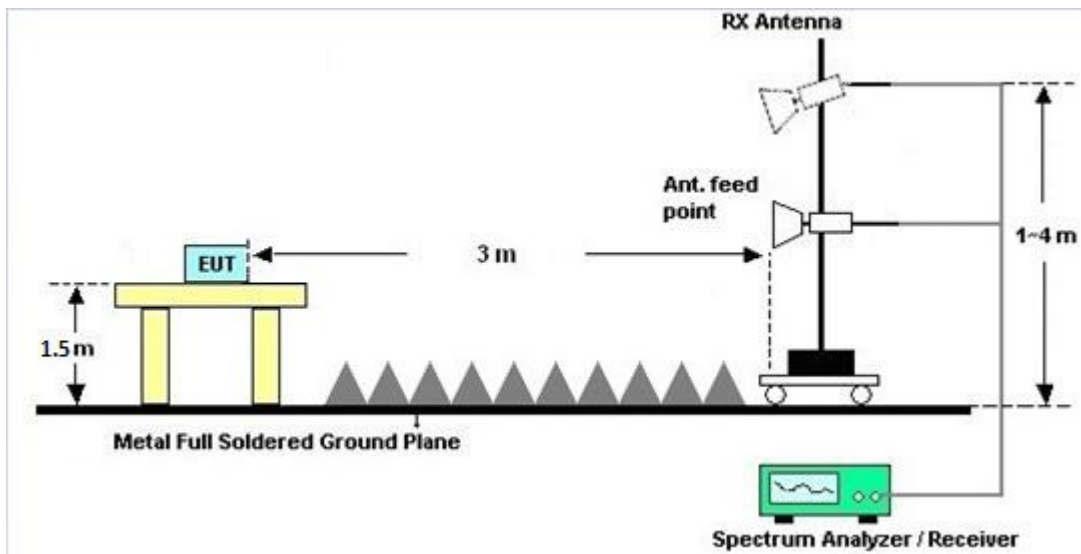

### 3.5.5 Test Results of Radiated Spurious Emissions (9 kHz ~ 30 MHz)

The low frequency, which started from 9 kHz to 30MHz, was pre-scanned and the result which was 20dB lower than the limit line per 15.31(o) was not reported.



**3.5.6 Test Result of Radiated Spurious at Band Edges**

Please refer to Appendix B and C.

**3.5.7 Test Result of Radiated Spurious Emission (30MHz ~ 10<sup>th</sup> Harmonic)**

Please refer to Appendix B and C.



### 3.6 AC Conducted Emission Measurement

#### 3.6.1 Limit of AC Conducted Emission

For equipment that is designed to be connected to the public utility (AC) power line, the radio frequency voltage that is conducted back onto the AC power line on any frequency or frequencies within the band 150 kHz to 30 MHz shall not exceed the limits in the following table.

Frequency of emission (MHz)	Conducted limit (dB $\mu$ V)	
	Quasi-peak	Average
0.15-0.5	66 to 56*	56 to 46*
0.5-5	56	46
5-30	60	50

\*Decreases with the logarithm of the frequency.

#### 3.6.2 Measuring Instruments

The section 4.0 of List of Measuring Equipment of this test report is used for test.

#### 3.6.3 Test Procedures

1. The EUT was placed 0.4 meter from the conducting wall of the shielding room was kept at least 80 centimeters from any other grounded conducting surface.
2. Connect EUT to the power mains through a line impedance stabilization network (LISN).
3. All the support units are connecting to the other LISN.
4. The LISN provides 50 ohm coupling impedance for the measuring instrument.
5. The FCC states that a 50 ohm, 50 microhenry LISN should be used.
6. Both sides of AC line were checked for maximum conducted interference.
7. The frequency range from 150 kHz to 30 MHz was searched.
8. Set the test-receiver system to Peak Detect Function and specified bandwidth (IF Bandwidth = 9kHz) with Maximum Hold Mode. Then measurement is also conducted by Average Detector and Quasi-Peak Detector Function respectively.

### 3.6.4 Test Setup

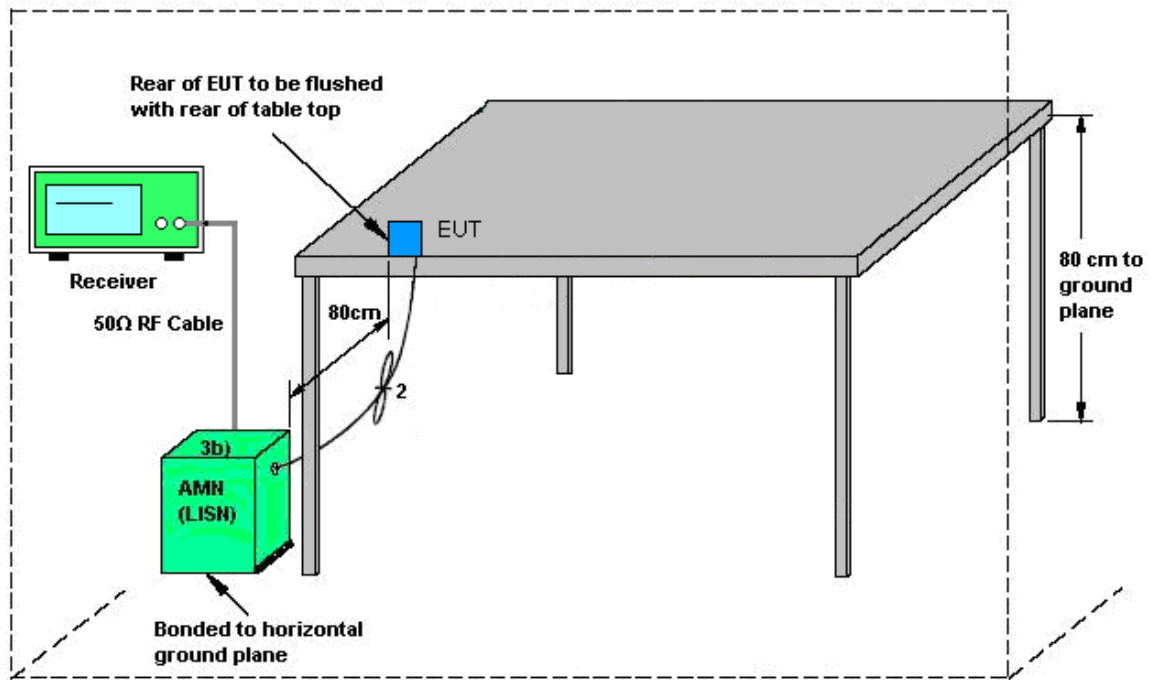

AMN = Artificial mains network (LISN)  
AE = Associated equipment  
EUT = Equipment under test  
ISN = Impedance stabilization network

### 3.6.5 Test Result of AC Conducted Emission

Test Mode :	Mode 1	Temperature :	24~25°C
Test Engineer :	Kai Chun Chu	Relative Humidity :	51~52%
Test Voltage :	120Vac / 60Hz	Phase :	Line
Function Type :	WLAN (2.4GHz) Link + Bluetooth Link + Camera (Rear) + USB HDD + Adapter + Micro SD + Micro USB Cable ( Data Link with Notebook) + Battery + Earphone		

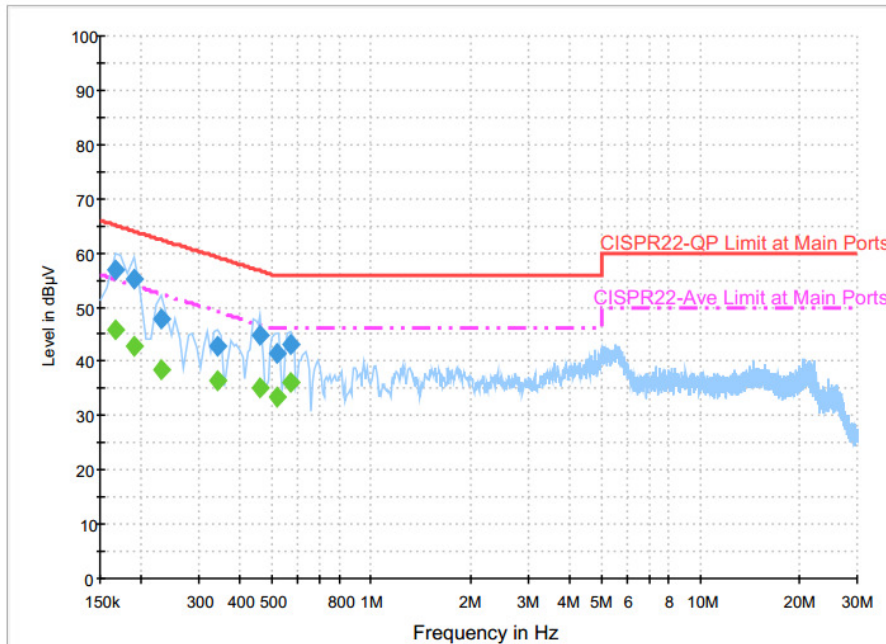

#### Final Result : Quasi-Peak

Frequency (MHz)	Quasi-Peak (dBµV)	Filter	Line	Corr. (dB)	Margin (dB)	Limit (dBµV)
0.166000	56.9	Off	L1	19.6	8.3	65.2
0.190000	55.1	Off	L1	19.6	8.9	64.0
0.230000	48.0	Off	L1	19.6	14.4	62.4
0.342000	42.8	Off	L1	19.6	16.4	59.2
0.462000	44.7	Off	L1	19.6	12.0	56.7
0.518000	41.6	Off	L1	19.6	14.4	56.0
0.566000	43.1	Off	L1	19.6	12.9	56.0

#### Final Result : Average

Frequency (MHz)	Average (dBµV)	Filter	Line	Corr. (dB)	Margin (dB)	Limit (dBµV)
0.166000	45.7	Off	L1	19.6	9.5	55.2
0.190000	42.8	Off	L1	19.6	11.2	54.0
0.230000	38.4	Off	L1	19.6	14.0	52.4
0.342000	36.5	Off	L1	19.6	12.7	49.2
0.462000	35.2	Off	L1	19.6	11.5	46.7
0.518000	33.6	Off	L1	19.6	12.4	46.0
0.566000	36.0	Off	L1	19.6	10.0	46.0



Test Mode :	Mode 1	Temperature :	24~25°C
Test Engineer :	Kai Chun Chu	Relative Humidity :	51~52%
Test Voltage :	120Vac / 60Hz	Phase :	Neutral
Function Type :	WLAN (2.4GHz) Link + Bluetooth Link + Camera (Rear) + USB HDD + Adapter + Micro SD + Micro USB Cable ( Data Link with Notebook) + Battery + Earphone		

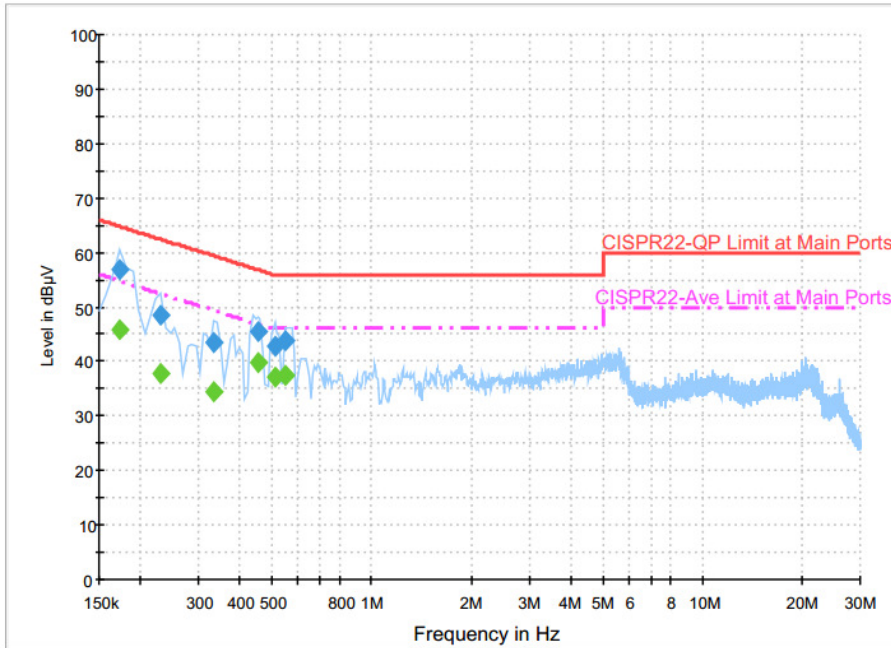

**Final Result : Quasi-Peak**

Frequency (MHz)	Quasi-Peak (dBµV)	Filter	Line	Corr. (dB)	Margin (dB)	Limit (dBµV)
0.174000	56.8	Off	N	19.6	8.0	64.8
0.230000	48.5	Off	N	19.6	13.9	62.4
0.334000	43.5	Off	N	19.6	15.9	59.4
0.454000	45.6	Off	N	19.6	11.2	56.8
0.510000	42.9	Off	N	19.6	13.1	56.0
0.550000	43.9	Off	N	19.6	12.1	56.0

**Final Result : Average**

Frequency (MHz)	Average (dBµV)	Filter	Line	Corr. (dB)	Margin (dB)	Limit (dBµV)
0.174000	45.7	Off	N	19.6	9.1	54.8
0.230000	37.9	Off	N	19.6	14.5	52.4
0.334000	34.5	Off	N	19.6	14.9	49.4
0.454000	39.8	Off	N	19.6	7.0	46.8
0.510000	37.3	Off	N	19.6	8.7	46.0
0.550000	37.4	Off	N	19.6	8.6	46.0





## **3.7 Antenna Requirements**

### **3.7.1 Standard Applicable**

If directional gain of transmitting antennas is greater than 6dBi, the power shall be reduced by the same level in dB comparing to gain minus 6dBi. The use of a permanently attached antenna or of an antenna that uses a unique coupling to the intentional radiator shall be considered sufficient to comply with the FCC rule.

### **3.7.2 Antenna Anti-Replacement Construction**

An embedded-in antenna design is used.

### **3.7.3 Antenna Gain**

The antenna peak gain of EUT is less than 6 dBi. Therefore, it is not necessary to reduce maximum peak output power limit.



## 4 List of Measuring Equipment

Instrument	Manufacturer	Model No.	Serial No.	Characteristics	Calibration Date	Test Date	Due Date	Remark
Power Meter	Agilent	E4416A	GB41292344	300MHz~40GHz	Jan. 14, 2015	Jan. 19, 2016 ~ Jan. 20, 2016	Jan. 13, 2016	Conducted (TH05-HY)
Power Sensor	Agilent	E9327A	US40441548	300MHz~40GHz	Jan. 14, 2015	Jan. 19, 2016 ~ Jan. 20, 2016	Jan. 13, 2016	Conducted (TH05-HY)
Digital Insulation Tester	Yokogawa	MY40-01	88NA2869	125V~1000V	Aug. 28, 2015	Jan. 19, 2016 ~ Jan. 20, 2016	Aug. 27, 2016	Conducted (TH05-HY)
Hygrometer	Testo	608-H2	41410069	N/A	Aug. 27, 2015	Jan. 19, 2016 ~ Jan. 20, 2016	Aug. 26, 2016	Conducted (TH05-HY)
Spectrum Analyzer	Rohde & Schwarz	FSP40	100057	9kHz-40GHz	Nov. 23, 2015	Jan. 19, 2016 ~ Jan. 20, 2016	Nov. 22, 2016	Conducted (TH05-HY)
Bilog Antenna	TESEQ	CBL 6111D	35414	30MHz~1GHz	Nov. 17, 2015	Jan. 05, 2016~ Jan. 13, 2016	Nov. 16, 2016	Radiation (03CH07-HY)
Double Ridge Horn Antenna	ESCO	3117	00075962	1GHz ~ 18GHz	Aug. 21, 2015	Jan. 05, 2016~ Jan. 13, 2016	Aug. 20, 2016	Radiation (03CH07-HY)
Horn Antenna	SCHWARZBECK	BBHA 9170	BBHA9170584	18GHz- 40GHz	Nov. 02, 2015	Jan. 05, 2016~ Jan. 13, 2016	Nov. 01, 2016	Radiation (03CH07-HY)
Hygrometer	Testo	608-H1	34897197	N/A	May. 04, 2015	Jan. 05, 2016~ Jan. 13, 2016	May. 03, 2016	Radiation (03CH07-HY)
Loop Antenna	Rohde & Schwarz	HFH2-Z2	100315	9 kHz~30 MHz	Sep. 02, 2015	Jan. 05, 2016~ Jan. 13, 2016	Sep. 01, 2016	Radiation (03CH07-HY)
Preamplifier	MITEQ	AMF-7D-0010 1800-30-10P	1590075	1GHz ~ 18GHz	Apr. 20, 2015	Jan. 05, 2016~ Jan. 13, 2016	Apr. 19, 2016	Radiation (03CH07-HY)
Preamplifier	Agilent	8449B	3008A02362	1GHz~ 26.5GHz	Oct. 19, 2015	Jan. 05, 2016~ Jan. 13, 2016	Oct. 18, 2016	Radiation (03CH07-HY)
Preamplifier	COM-POWER	PA-103A	161241	10MHz-1000MHz	Mar. 12, 2015	Jan. 05, 2016~ Jan. 13, 2016	Mar. 11, 2016	Radiation (03CH07-HY)
Spectrum Analyzer	Agilent	N9010A	MY53470118	10Hz~44GHz	Mar. 03, 2015	Jan. 05, 2016~ Jan. 13, 2016	Mar. 02, 2016	Radiation (03CH07-HY)
RF Cable	HUBER + SUHNER	SUCOFLEX 104	MY84209521	1GHz~40GHz	Dec. 02, 2015	Jan. 05, 2016~ Jan. 13, 2016	Dec. 01, 2016	Radiation (03CH07-HY)
RF Cable	HUBER + SUHNER	SUCOFLEX 104	MY84209521	9kHz~1GHz	Dec. 02, 2015	Jan. 05, 2016~ Jan. 13, 2016	Dec. 01, 2016	Radiation (03CH07-HY)
Controller	ChainTek	Chaintek 3000	N/A	Control Turn table	N/A	Jan. 05, 2016~ Jan. 13, 2016	N/A	Radiation (03CH07-HY)
Controller	Max-Full	MF7802	MF780208368	Control Ant Mast	N/A	Jan. 05, 2016~ Jan. 13, 2016	N/A	Radiation (03CH07-HY)
Antenna Mast	Max-Full	MFA520BS	N/A	1m~4m	N/A	Jan. 05, 2016~ Jan. 13, 2016	N/A	Radiation (03CH07-HY)
Turn Table	ChainTek	Chaintek 3000	N/A	0~360 degree	N/A	Jan. 05, 2016~ Jan. 13, 2016	N/A	Radiation (03CH07-HY)
EMI Test Receiver	Keysight	N9038A(MXE )	MY54130085	20Hz ~ 8.4GHz	Nov. 04, 2015	Jan. 05, 2016~ Jan. 13, 2016	Nov. 03, 2016	Radiation (03CH07-HY)
Preamplifier	MITEQ	JS44-180040 00-33-8P	1840917	18GHz ~ 40GHz	Jun. 02, 2015	Jan. 05, 2016~ Jan. 13, 2016	Jun. 01, 2016	Radiation (03CH07-HY)



Instrument	Manufacturer	Model No.	Serial No.	Characteristics	Calibration Date	Test Date	Due Date	Remark
AC Power Source	ChainTek	APC-1000W	N/A	N/A	N/A	Jan. 19, 2016	N/A	Conduction (CO05-HY)
EMI Test Receiver	Rohde & Schwarz	ESCI 7	100724	9kHz~7GHz	Aug. 26, 2015	Jan. 19, 2016	Aug. 25, 2016	Conduction (CO05-HY)
Hygrometer	Testo	608-H1	34913912	N/A	Apr. 20, 2015	Jan. 19, 2016	Apr. 19, 2016	Conduction (CO05-HY)
LISN	Rohde & Schwarz	ENV216	100080	9kHz~30MHz	Dec. 02, 2015	Jan. 19, 2016	Dec. 01, 2016	Conduction (CO05-HY)
LISN	Rohde & Schwarz	ENV216	100081	9kHz~30MHz	Dec. 14, 2015	Jan. 19, 2016	Dec. 13, 2016	Conduction (CO05-HY)
LF Cable	HUBER + SUHNER	RG-214/U	LF01	N/A	Jan. 08, 2016	Jan. 19, 2016	Jan. 07, 2017	Conduction (CO05-HY)
Pulse Limiter	Rohde & Schwarz	ESH3-Z2	100851	N/A	Jan. 08, 2016	Jan. 19, 2016	Jan. 07, 2017	Conduction (CO05-HY)



## 5 Uncertainty of Evaluation

### Uncertainty of Conducted Emission Measurement (150 kHz ~ 30 MHz)

Measuring Uncertainty for a Level of Confidence of 95% ( $U = 2Uc(y)$ )	2.70
---	------

### Uncertainty of Radiated Emission Measurement (30 MHz ~ 1000 MHz)

Measuring Uncertainty for a Level of Confidence of 95% ( $U = 2Uc(y)$ )	4.50
---	------



## **Appendix A. Conducted Test Results**

**Bluetooth Low Energy**

Test Engineer:	AC Chang	Temperature:	21~25	°C
Test Date:	2015/01/19 ~ 2015/01/20	Relative Humidity:	51~54	%

**TEST RESULTS DATA**  
**6dB and 99% Occupied Bandwidth**

Mod.	Data Rate	NTX	CH.	Freq. (MHz)	99% Occupied BW (MHz)	6dB BW (MHz)	6dB BW Limit (MHz)	Pass/Fail
BLE	1Mbps	1	0	2402	1.03	0.70	0.50	Pass
BLE	1Mbps	1	19	2440	1.04	0.72	0.50	Pass
BLE	1Mbps	1	39	2480	1.03	0.71	0.50	Pass

**TEST RESULTS DATA**  
**Peak Power Table**

Mod.	Data Rate	NTX	CH.	Freq. (MHz)	Peak Conducted Power (dBm)	Conducted Power Limit (dBm)	DG (dBi)	EIRP Power (dBm)	EIRP Power Limit (dBm)	Pass /Fail
BLE	1Mbps	1	0	2402	1.39	30.00	2.30	3.69	36.00	Pass
BLE	1Mbps	1	19	2440	1.65	30.00	2.30	3.95	36.00	Pass
BLE	1Mbps	1	39	2480	2.67	30.00	2.30	4.97	36.00	Pass

**TEST RESULTS DATA**  
**Average Power Table**  
**(Reporting Only)**

Mod.	Data Rate	NTX	CH.	Freq. (MHz)	Duty Factor (dB)	Average Conducted Power (dBm)
BLE	1Mbps	1	0	2402	0.00	0.93
BLE	1Mbps	1	19	2440	0.00	1.23
BLE	1Mbps	1	39	2480	0.00	2.33

**TEST RESULTS DATA**  
**Peak Power Density**

Mod.	Data Rate	NTX	CH.	Freq. (MHz)	Peak PSD (dBm /100kHz)	Peak PSD (dBm /3kHz)	DG (dBi)	Peak PSD Limit (dBm /3kHz)	Pass/Fail
BLE	1Mbps	1	0	2402	-0.51	-16.41	2.30	8.00	Pass
BLE	1Mbps	1	19	2440	-0.12	-16.10	2.30	8.00	Pass
BLE	1Mbps	1	39	2480	0.79	-15.06	2.30	8.00	Pass

Note: PSD (dBm/ 100kHz) is a reference level used for Conducted Band Edges and Conducted Spurious Emission 20dBc limit.



## Appendix B. Radiated Spurious Emission

Test Engineer :	Luke Chang, Jesse Wang, and James Chiu	Temperature :	20~21°C
		Relative Humidity :	59~62%

15C 2.4GHz 2400~2483.5MHz

BLE (Band Edge @ 3m)

BLE	Note	Frequency	Level	Over	Limit	Read	Antenna	Cable	Preamp	Ant	Table	Peak	Pol.	
				Limit	Line	Level	Factor	Loss	Factor	Pos	Pos	Avg.		
		( MHz )	( dBμV/m )	( dB )	( dBμV/m )	( dBμV )	( dB/m )	( dB )	( dB )	( cm )	( deg )	( P/A )	( H/V )	
BLE CH 00 2402MHz		2389.65	56.05	-17.95	74	50.48	32.18	7.75	34.36	217	232	P	H	
		2387.04	45.19	-8.81	54	39.62	32.18	7.75	34.36	217	232	A	H	
	*	2402.254	94.69	-	-	89.08	32.18	7.75	34.32	217	232	P	H	
	*	2402.004	94.31	-	-	88.7	32.18	7.75	34.32	217	232	A	H	
													H	
														H
			2330.07	56.2	-17.8	74	50.95	32.09	7.6	34.44	161	64	P	V
			2389.47	45.2	-8.8	54	39.63	32.18	7.75	34.36	161	64	A	V
	*		2402.254	99.23	-	-	93.62	32.18	7.75	34.32	161	64	P	V
	*		2402.004	98.88	-	-	93.27	32.18	7.75	34.32	161	64	A	V
														V
													V	
BLE CH 19 2440MHz		2380.11	56.36	-17.64	74	50.81	32.16	7.75	34.36	205	232	P	H	
		2388.57	45.2	-8.8	54	39.63	32.18	7.75	34.36	205	232	A	H	
	*	2440.331	97.84	-	-	92.04	32.24	7.83	34.27	205	232	P	H	
	*	2439.997	97.5	-	-	91.7	32.24	7.83	34.27	205	232	A	H	
			2488.04	56.39	-17.61	74	50.37	32.3	7.91	34.19	205	232	P	H
			2491	45.7	-8.3	54	39.68	32.3	7.91	34.19	205	232	A	H
			2388.75	56.2	-17.8	74	50.63	32.18	7.75	34.36	100	89	P	V
			2383.44	45.2	-8.8	54	39.65	32.16	7.75	34.36	100	89	A	V
	*		2439.83	100.45	-	-	94.65	32.24	7.83	34.27	100	89	P	V
	*		2439.997	100.11	-	-	94.31	32.24	7.83	34.27	100	89	A	V
			2499.24	56.23	-17.77	74	50.17	32.3	7.91	34.15	100	89	P	V
		2484.56	45.69	-8.31	54	39.69	32.28	7.91	34.19	100	89	A	V	



<b>BLE CH 39 2480MHz</b>	*	2480.243	99.55	-	-	93.55	32.28	7.91	34.19	191	231	P	H
	*	2479.993	99.18	-	-	93.18	32.28	7.91	34.19	191	231	A	H
		2492.68	56.57	-17.43	74	50.51	32.3	7.91	34.15	191	231	P	H
		2486.16	46.21	-7.79	54	40.21	32.28	7.91	34.19	191	231	A	H
													H
													H
	*	2480.243	100.64	-	-	94.64	32.28	7.91	34.19	101	90	P	V
	*	2479.993	99.94	-	-	93.94	32.28	7.91	34.19	101	90	A	V
		2484.64	56.76	-17.24	74	50.76	32.28	7.91	34.19	101	90	P	V
		2483.6	46.28	-7.72	54	40.28	32.28	7.91	34.19	101	90	A	V
													V
													V
Remark	1. No other spurious found. 2. All results are PASS against Peak and Average limit line.												





15C 2.4GHz 2400~2483.5MHz

BLE (Harmonic @ 3m)

BLE	Note	Frequency	Level	Over	Limit	Read	Antenna	Cable	Preamp	Ant	Table	Peak	Pol.	
		( MHz )	( dBμV/m )	( dB )	( dBμV/m )	( dBμV )	( dB/m )	( dB )	( dB )	( cm )	( deg )	( P/A )	( H/V )	
BLE CH 00 2402MHz		4806	44.46	-29.54	74	58.77	34.25	11.11	59.67	100	0	P	H	
													H	
													H	
													H	
			4806	43.56	-30.44	74	57.87	34.25	11.11	59.67	100	0	P	V
														V
														V
BLE CH 19 2440MHz		4878	44.11	-29.89	74	58.17	34.3	11.21	59.57	100	0	P	H	
		7320	46.79	-27.21	74	54.6	35.6	15.08	58.49	100	0	P	H	
													H	
													H	
			4878	41.46	-32.54	74	55.52	34.3	11.21	59.57	100	0	P	V
			7320	48.32	-25.68	74	56.13	35.6	15.08	58.49	100	0	P	V
														V
BLE CH 39 2480MHz		4962	46	-28	74	59.76	34.37	11.32	59.45	100	0	P	H	
		7440	48.08	-25.92	74	55.99	35.6	15.13	58.64	100	0	P	H	
													H	
													H	
			4962	44.5	-29.5	74	58.26	34.37	11.32	59.45	100	0	P	V
			7440	46.68	-27.32	74	54.59	35.6	15.13	58.64	100	0	P	V
														V
Remark	1. No other spurious found. 2. All results are PASS against Peak and Average limit line.													



15C Emission below 1GHz

2.4GHz BLE (LF)

BLE	Note	Frequency	Level	Over	Limit	Read	Antenna	Cable	Preamp	Ant	Table	Peak	Pol.	
		( MHz )	( dBμV/m )	( dB )	( dBμV/m )	( dBμV )	( dB/m )	( dB )	( dB )	( cm )	( deg )	(P/A)	(H/V)	
2.4GHz BLE LF		30	28.23	-11.77	40	32.26	25.7	1.77	31.5	100	0	P	H	
		159.06	28.65	-14.85	43.5	40.28	16.95	2.61	31.19			P	H	
		235.74	25.09	-20.91	46	35.75	17.38	2.96	31			P	H	
		396.6	25.21	-20.79	46	30.29	22.32	3.52	30.92			P	H	
		765.5	32.28	-13.72	46	30.29	27.88	4.48	30.37			P	H	
		967.1	35.24	-18.76	54	30.06	30.57	4.94	30.33			P	H	
														H
														H
														H
														H
														H
														H
			47.82	32.43	-7.57	40	45.66	16.2	1.77	31.2	100	0	P	V
			159.87	24.03	-19.47	43.5	35.72	16.9	2.61	31.2			P	V
			264.36	23.71	-22.29	46	32.05	19.5	3.16	31			P	V
			378.4	24.09	-21.91	46	29.87	21.84	3.39	31.01			P	V
			580	29.9	-16.1	46	31.23	25.34	4.01	30.68			P	V
			979.7	34.94	-19.06	54	29.74	30.54	4.94	30.28			P	V
														V
														V
													V	
													V	
													V	
Remark	1. No other spurious found. 2. All results are PASS against limit line.													



**Note symbol**

*	<b>Fundamental Frequency</b> which can be ignored. However, the level of any unwanted emissions shall not exceed the level of the fundamental frequency per 15.209(c).
!	Test result is <b>over limit</b> line.
P/A	<b>Peak</b> or <b>Average</b>
H/V	<b>Horizontal</b> or <b>Vertical</b>



A calculation example for radiated spurious emission is shown as below:

WIFI	Note	Frequency	Level	Over	Limit	Read	Antenna	Cable	Preamp	Ant	Table	Peak	Pol.
Ant.				Limit	Line	Level	Factor	Loss	Factor	Pos	Pos	Avg.	
1+2		( MHz )	( dBμV/m )	( dB )	( dBμV/m )	( dBμV )	( dB/m )	( dB )	( dB )	( cm )	( deg )	(P/A)	(H/V)
802.11b		2390	55.45	-18.55	74	54.51	32.22	4.58	35.86	103	308	P	H
CH 01		2390	43.54	-10.46	54	42.6	32.22	4.58	35.86	103	308	A	H
2412MHz													

- Level(dBμV/m) =  
Antenna Factor(dB/m) + Cable Loss(dB) + Read Level(dBμV) - Preamp Factor(dB)
- Over Limit(dB) = Level(dBμV/m) – Limit Line(dBμV/m)

**For Peak Limit @ 2390MHz:**

- Level(dBμV/m)  
= Antenna Factor(dB/m) + Cable Loss(dB) + Read Level(dBμV) - Preamp Factor(dB)  
= 32.22(dB/m) + 4.58(dB) + 54.51(dBμV) – 35.86 (dB)  
= 55.45 (dBμV/m)
- Over Limit(dB)  
= Level(dBμV/m) – Limit Line(dBμV/m)  
= 55.45(dBμV/m) – 74(dBμV/m)  
= -18.55(dB)

**For Average Limit @ 2390MHz:**

- Level(dBμV/m)  
= Antenna Factor(dB/m) + Cable Loss(dB) + Read Level(dBμV) - Preamp Factor(dB)  
= 32.22(dB/m) + 4.58(dB) + 42.6(dBμV) – 35.86 (dB)  
= 43.54 (dBμV/m)
- Over Limit(dB)  
= Level(dBμV/m) – Limit Line(dBμV/m)  
= 43.54(dBμV/m) – 54(dBμV/m)  
= -10.46(dB)

**Both peak and average measured complies with the limit line, so test result is “PASS”.**



## Appendix C. Radiated Spurious Emission

Test Engineer :	Luke Chang, Jesse Wang, and James Chiu	Temperature :	20~21°C
		Relative Humidity :	59~62%

2.4GHz 2400~2483.5MHz

BLE (Band Edge @ 3m)

BLE	2.4GHz 2400~2483.5MHz Band Edge @ 3m	
ANT	BLE CH00 2402MHz	
1	Horizontal	Vertical
Peak	<p>Site : 03CH07.HY            Condition : FCC CLASS-B 3m HF-ANT_130829 HORIZONTAL            : RBW:1000.000kHz VBW:3000.000kHz SWT:Auto            Detector : Peak            Project : FR 5D2503            Mode : 4</p>	<p>Site : 03CH07.HY            Condition : FCC CLASS-B 3m HF-ANT_130829 VERTICAL            : RBW:1000.000kHz VBW:3000.000kHz SWT:Auto            Detector : Peak            Project : FR 5D2503            Mode : 4</p>

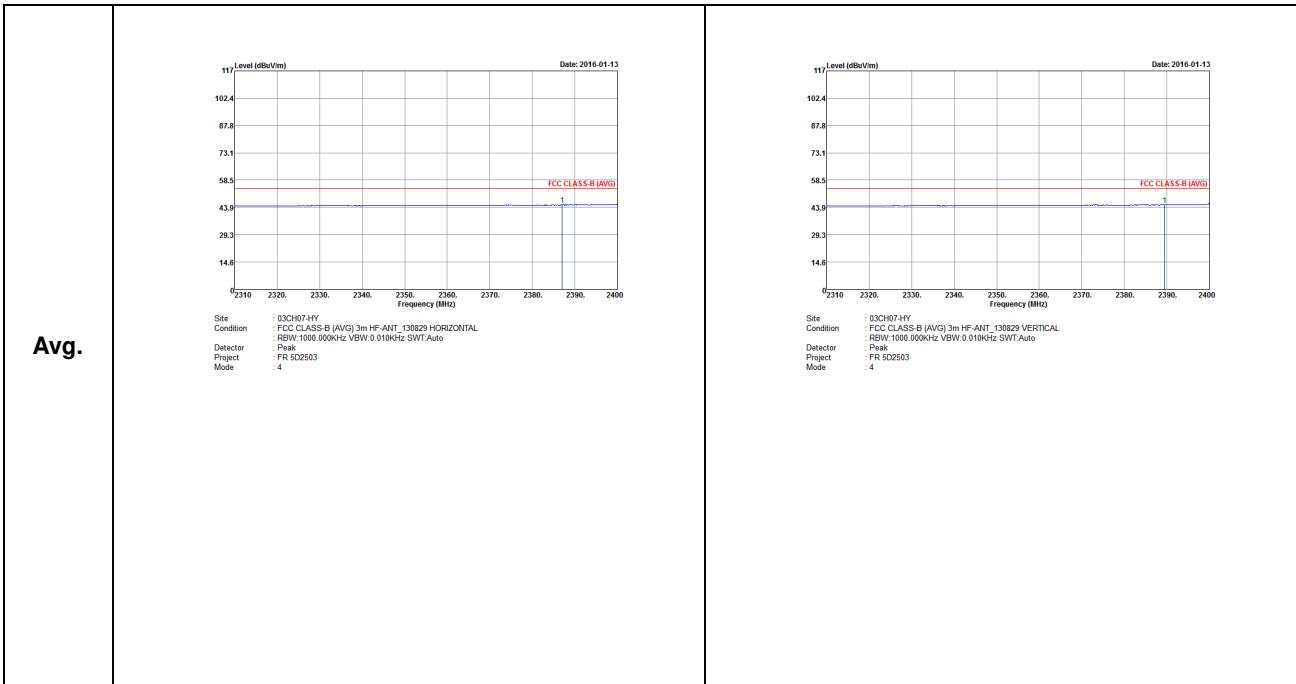

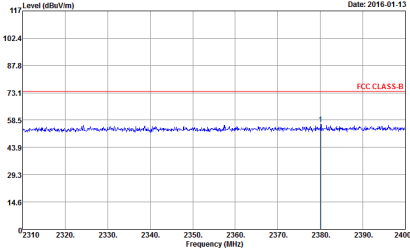
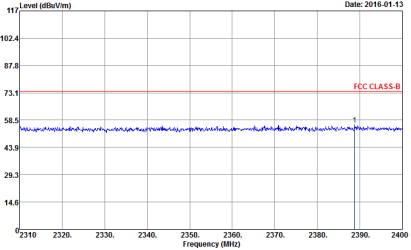
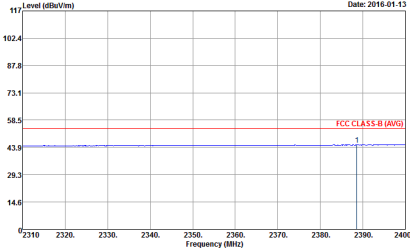
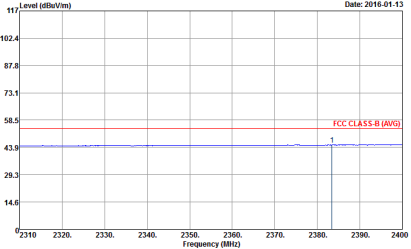

BLE	2.4GHz 2400~2483.5MHz Band Edge @ 3m	
ANT	BLE CH19 2440MHz - L	
1	Horizontal	Vertical
Peak	 <p>Site : 03CH07.HY            Condition : FCC CLASS-B 3m HF-ANT_130829 HORIZONTAL            RBW:1000.000kHz VBW:3000.000kHz SWT:Auto            Detector : Peak            Project : FR 5D2503            Mode : 5</p>	 <p>Site : 03CH07.HY            Condition : FCC CLASS-B 3m HF-ANT_130829 VERTICAL            RBW:1000.000kHz VBW:3000.000kHz SWT:Auto            Detector : Peak            Project : FR 5D2503            Mode : 5</p>
Avg.	 <p>Site : 03CH07.HY            Condition : FCC CLASS-B (AVG) 3m HF-ANT_130829 HORIZONTAL            RBW:1000.000kHz VBW:0.010kHz SWT:Auto            Detector : Peak            Project : FR 5D2503            Mode : 5</p>	 <p>Site : 03CH07.HY            Condition : FCC CLASS-B (AVG) 3m HF-ANT_130829 VERTICAL            RBW:1000.000kHz VBW:0.010kHz SWT:Auto            Detector : Peak            Project : FR 5D2503            Mode : 5</p>

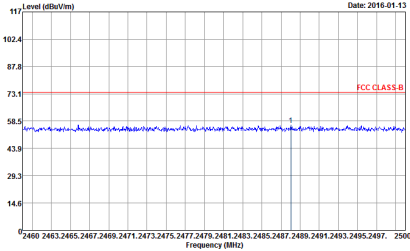
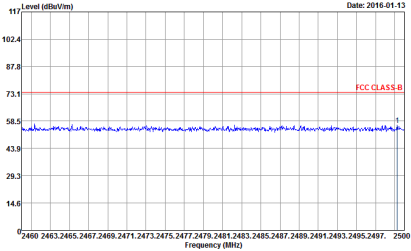
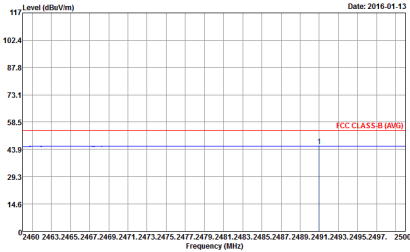
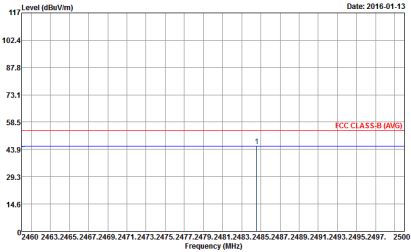

BLE	2.4GHz 2400~2483.5MHz Band Edge @ 3m	
ANT	BLE CH19 2440MHz - R	
1	Horizontal	Vertical
Peak	 <p>Date: 2016-01-13</p> <p>Site : 03CH07-HY            Condition : FCC CLASS-B 3m HF-ANT_130829 HORIZONTAL            Detector : Peak            Project : FR 5D2503            Mode : 5</p>	 <p>Date: 2016-01-13</p> <p>Site : 03CH07-HY            Condition : FCC CLASS-B 3m HF-ANT_130829 VERTICAL            Detector : Peak            Project : FR 5D2503            Mode : 5</p>
Avg.	 <p>Date: 2016-01-13</p> <p>Site : 03CH07-HY            Condition : FCC CLASS-B (AVG) 3m HF-ANT_130829 HORIZONTAL            Detector : Peak            Project : FR 5D2503            Mode : 5</p>	 <p>Date: 2016-01-13</p> <p>Site : 03CH07-HY            Condition : FCC CLASS-B (AVG) 3m HF-ANT_130829 VERTICAL            Detector : Peak            Project : FR 5D2503            Mode : 5</p>



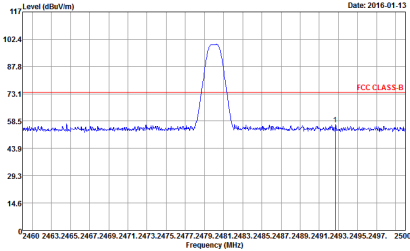
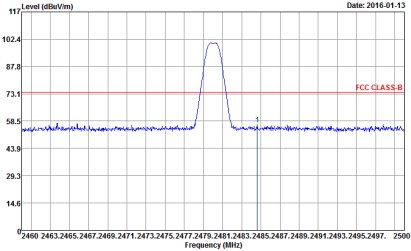
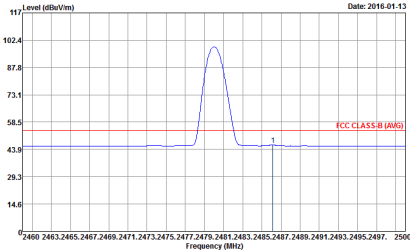
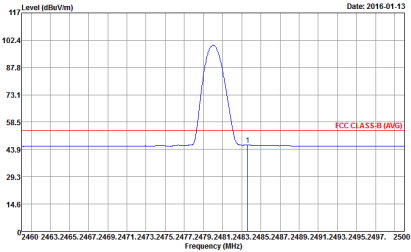

BLE	2.4GHz 2400~2483.5MHz Band Edge @ 3m	
ANT	BLE CH39 2480MHz	
1	Horizontal	Vertical
Peak	 <p>Site : 03CH07.HY            Condition : FCC CLASS-B 3m HF-ANT_130829 HORIZONTAL            Detector : Peak            Project : FR 5D2503            Mode : 6</p>	 <p>Site : 03CH07.HY            Condition : FCC CLASS-B 3m HF-ANT_130829 VERTICAL            Detector : Peak            Project : FR 5D2503            Mode : 6</p>
Avg.	 <p>Site : 03CH07.HY            Condition : FCC CLASS-B (AVG) 3m HF-ANT_130829 HORIZONTAL            Detector : Peak            Project : FR 5D2503            Mode : 6</p>	 <p>Site : 03CH07.HY            Condition : FCC CLASS-B (AVG) 3m HF-ANT_130829 VERTICAL            Detector : Peak            Project : FR 5D2503            Mode : 6</p>



2.4GHz 2400~2483.5MHz

BLE (Harmonic @ 3m)

<b>BLE</b>	<b>2.4GHz 2400~2483.5MHz Harmonic @ 3m</b>	
<b>ANT</b>	<b>BLE CH00 2402MHz</b>	
<b>1</b>	<b>Horizontal</b>	<b>Vertical</b>
<b>Peak Avg.</b>	<p>Site : 03CH07.HY Condition : FCC CLASS-B 3m SHF-EHF_131029 HORIZONTAL Detector : Peak Project : FR 5D2503 Mode : 4</p>	<p>Site : 03CH07.HY Condition : FCC CLASS-B 3m SHF-EHF_131029 VERTICAL Detector : Peak Project : FR 5D2503 Mode : 4</p>

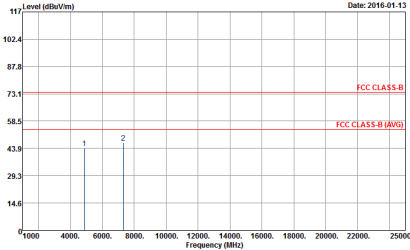
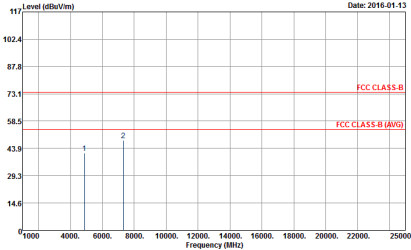

<b>BLE</b>	<b>2.4GHz 2400~2483.5MHz Harmonic @ 3m</b>	
<b>ANT</b>	<b>BLE CH19 2440MHz</b>	
<b>1</b>	<b>Horizontal</b>	<b>Vertical</b>
<b>Peak Avg.</b>	 <p style="font-size: small;">Date: 2016-01-13</p> <p style="font-size: x-small;">Site : 03CH07.HY Condition : FCC CLASS-B 3m SHF-EHF_131029 HORIZONTAL Detector : Peak Project : FR-02503 Mode : 5</p>	 <p style="font-size: small;">Date: 2016-01-13</p> <p style="font-size: x-small;">Site : 03CH07.HY Condition : FCC CLASS-B 3m SHF-EHF_131029 VERTICAL Detector : Peak Project : FR-02503 Mode : 5</p>



<b>BLE</b>	<b>2.4GHz 2400~2483.5MHz Band Edge @ 3m</b>	
<b>ANT</b>	<b>BLE CH39 2480MHZ</b>	
<b>1</b>	<b>Horizontal</b>	<b>Vertical</b>
<b>Peak</b>	<p>Site : 03CH07.HY          Condition : FCC CLASS-B 3m SHF-EHF_131029 HORIZONTAL          Detector : Peak          Project : FR-02503          Mode : 6</p>	<p>Site : 03CH07.HY          Condition : FCC CLASS-B 3m SHF-EHF_131029 VERTICAL          Detector : Peak          Project : FR-02503          Mode : 6</p>



Emission below 1GHz

2.4GHz BLE (LF)

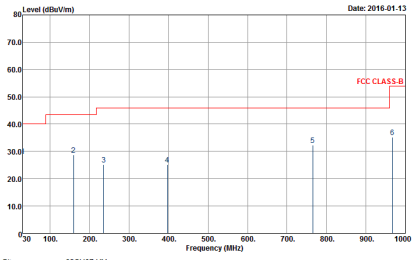
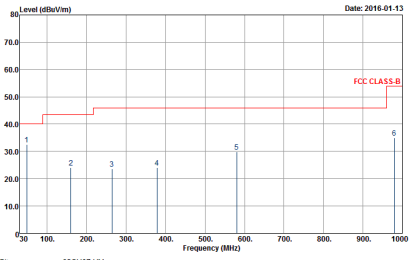
BLE	2.4GHz 2400~2483.5MHz	
ANT	BLE LF	
1	Horizontal	Vertical
<p>QP / Peak</p>	 <p>Site : 03C167.HY Condition : FCC CLASS-B 3m LF_ANT_35414(6) HORIZONTAL Detector : Peak Project : FR 5D2503 Mode : 20</p>	 <p>Site : 03C167.HY Condition : FCC CLASS-B 3m LF_ANT_35414(6) VERTICAL Detector : Peak Project : FR 5D2503 Mode : 20</p>