

# APPROVAL SHEET

## (RoHS)

CUSTOMER : \_\_\_\_\_  
 CUSTOMER'S : \_\_\_\_\_  
 PART NO. : \_\_\_\_\_  
 DESCRIPTION : Ceramic Block Antenna  
 PART NO. : CBA-1204-2G4S2-A1  
 DATE : \_\_\_\_\_  
 AUTHORIZED BY : Yunwei Lin

	FULLY APPROVED	PARTIALLY APPROVED	REJECTED
SIGN			
SUGGESTION			

美磊科技股份有限公司

MAG. LAYERS SCIENTIFIC-TECHNICS CO., LTD  
 HEAD OFFICE / HSINCHU PLANT

No 18, Tz-Chiang Road, Hsin-Chu Industrial Park, Hsin-Chu, Taiwan

TEL: +886-3-5972488 FAX: +886-3-5972477

<http://www.maglayers.com.tw>

E-mail : [info@maglayers.com.tw](mailto:info@maglayers.com.tw)



MAG.LAYERS

## APPLICATION

WLAN, Home RF, Bluetooth, etc.

## FEATURES

- **Compact Size**  
Miniaturized SMD packaged in low profile and lightweight.
- **Wide Bandwidth**
- **High Soldering Heat Resistance**  
High quality termination allows both flow and re-flow soldering methods to be applied.
- **Available in Tape and Reel Packaging for Automatic Mounting**
- **No Ground Clearance to Save Real Estate**

## PRODUCT IDENTIFICATION

C B A - 1 2 0 4 - ### x x - A 1  
①                      ②                      ③                      ④

- ① Product Code
- ② Dimension Code
- ③ Series Type (### represents center frequency and xx represents material type)
- ④ Design Code

## ELECTRICAL REQUIREMENTS

Part NO.	Frequency	Impedance	Bandwidth*	Gain*	VSWR	Polarization
CBA-1204-2G4S2-A1	2450 MHz	50 Ohms	~100 MHz	>1 dBi	2.0 max.	Linear

\*Depend on PCB layout.

## PRODUCT DIMENSION

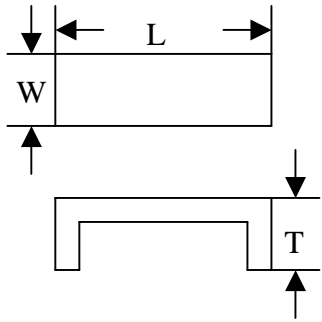

L	W	T
12.0±0.2	4.0±0.2	3.5±0.2

NOTE : Dimensions in mm

## TERMINAL CONFIGURATION

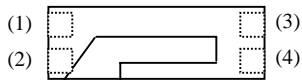

- ① GND
- ② Feed Termination
- ③ N.C.
- ④ N.C.

## MEASURING DIAGRAM

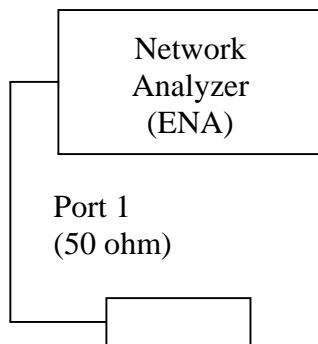

Test Instrument:  
Agilent E5071A Network Analyzer

## RECOMMENDED PCB LAYOUT

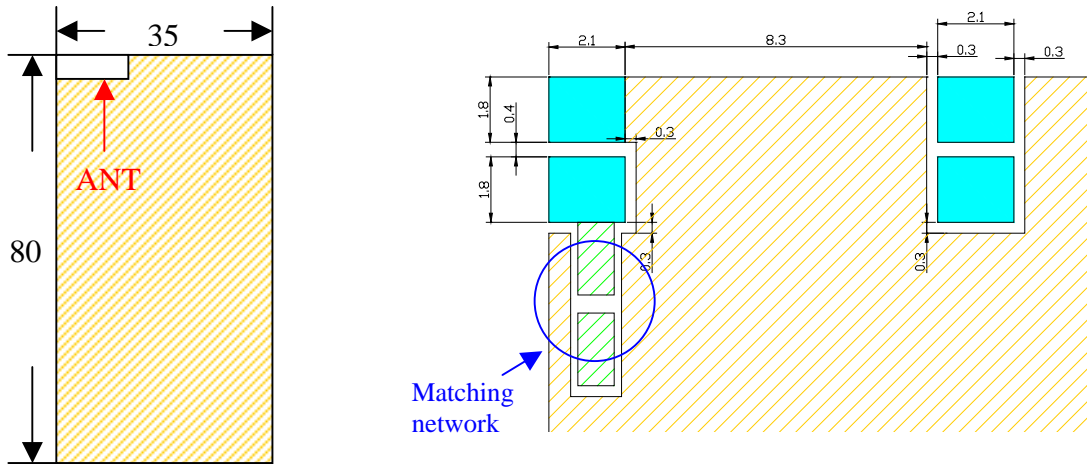

 Land

 50 ohm feed line

 Ground

Unit : mm

## ELECTRICAL CHARACTERISTICS ( T=25°C)

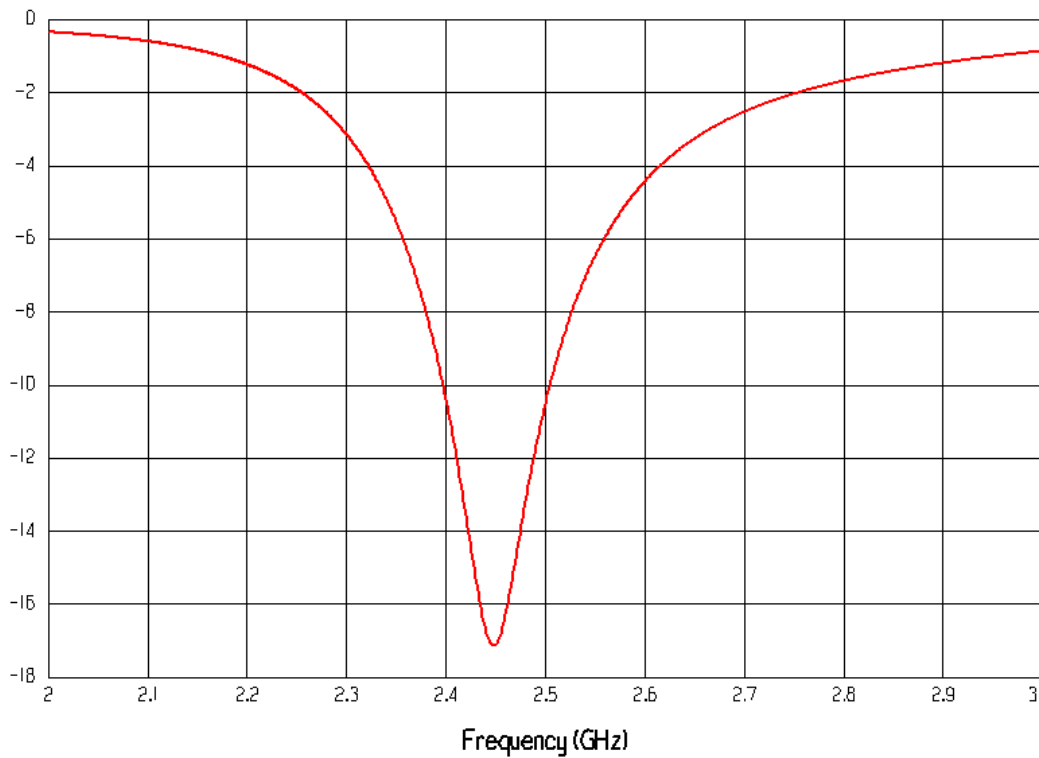

# RADIATION PATTERN

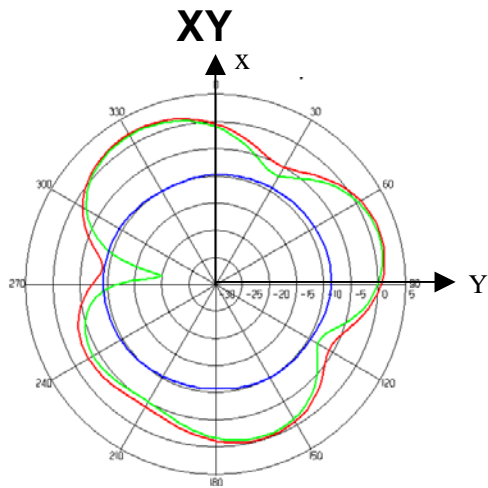

- Total
- Horizontal
- Vertical

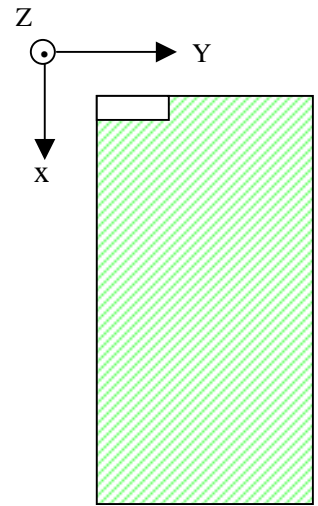

Peak Gain = 1.9881876 dBi

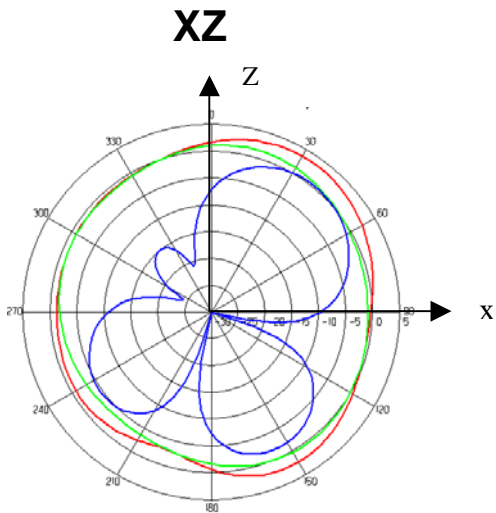

- Total
- Horizontal
- Vertical

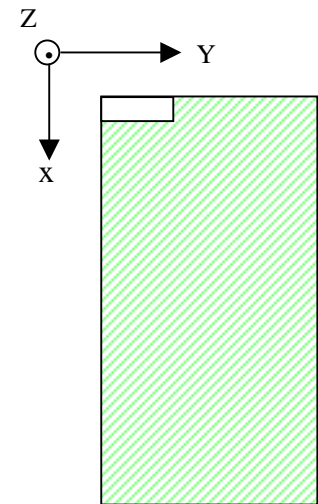

Peak Gain = 3.5804697 dBi

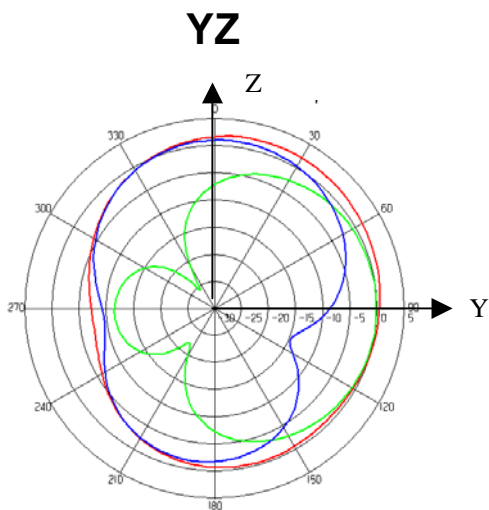

- Total
- Horizontal
- Vertical

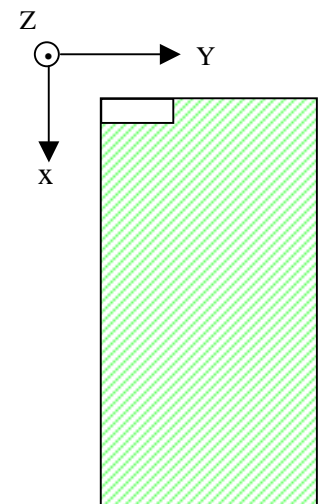

Peak Gain = 2.0663171 dBi

# PACKAGING FOR SMC

## Peel-off force

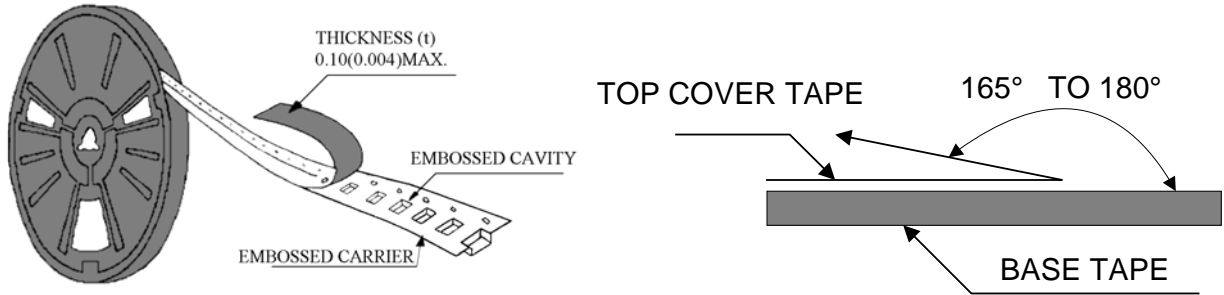

The force for peeling off cover tape is 10 grams in the arrow direction.

## Dimension (Unit: mm)

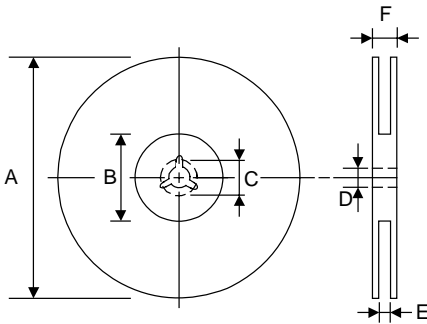

TYPE	A	B	C	D	E	F
8 mm	178±1	60 +0.5 -0	-	13 ±0.2	9 ±0.5	12 ±0.5
16mm	330±2	100 ±1				-

## Taping quantity

SERIES	5824	5220 5320	4532 8040	4516	3225	3216 2520	2012 1608	1005
PCS/Reel	5000	3000	1000	2000	2500	3000	4000	10000

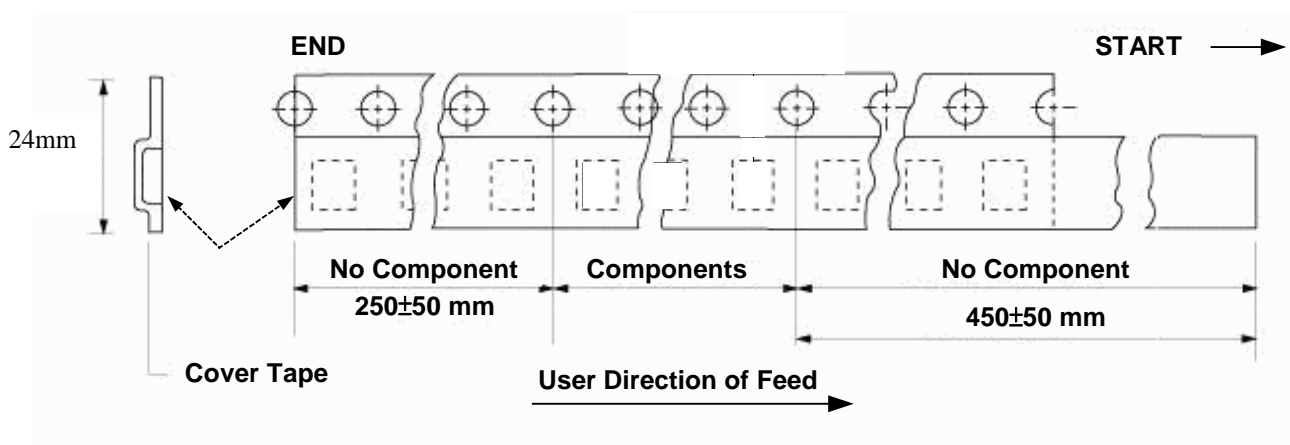

## TAPE PACKING CASE

- 2 reels/box

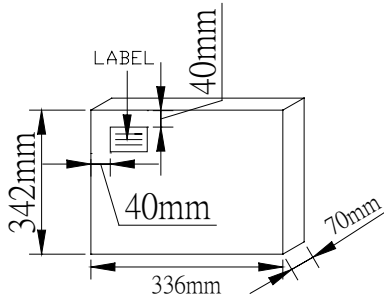

- 5 BOX / CARTON

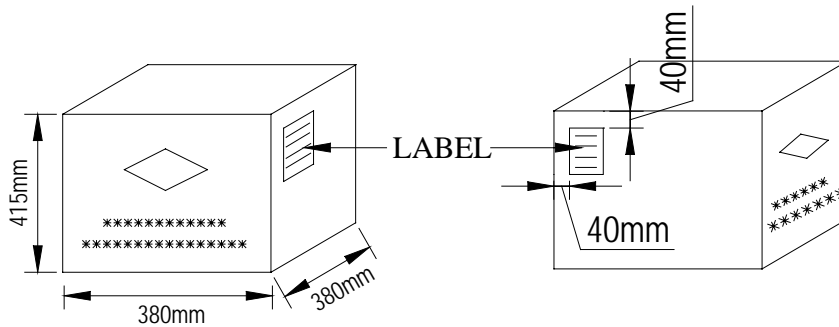

## ATTENTION REGARDING PCB BENDING

- (a) PCB shall be designed so that products are not subjected to the mechanical stress for board warpage. Product shall be located in the sideway direction to the mechanical stress.

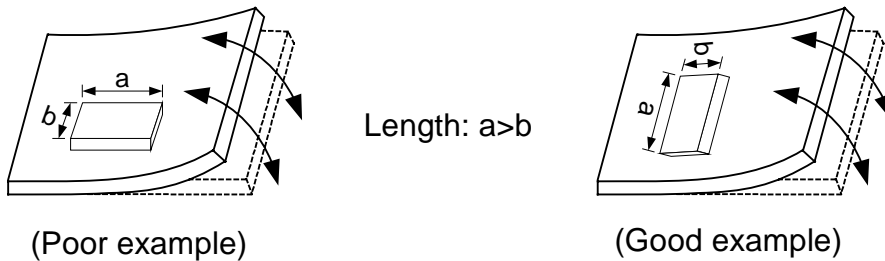

- (b) Products (A,B,C,D) shall be located carefully so that products are not subjected to the mechanical stress due to warping the board. Because they may be subjected to the mechanical stress in order of  $A > C > B \approx D$ .

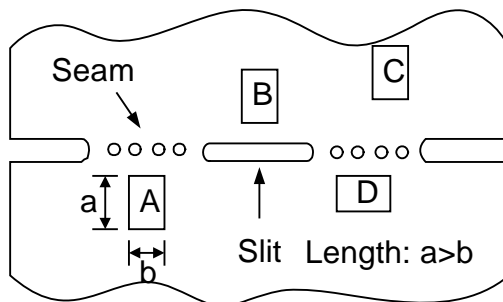

## RELIABILITY TEST

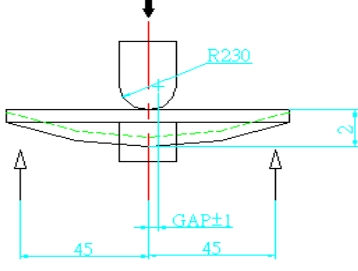
Item	Condition	Specification
<b>Thermal shock</b>	-40°C~+85°C for 100 cycles each cycle being 30 min	No apparent damage Fulfill the electrical spec. after test
<b>Humidity resistance</b>	85±2°C, 80~90% R.H. for 500 hours	No apparent damage Fulfill the electrical spec. after test
<b>High temperature resistance</b>	+85±2°C for 500 hours	No apparent damage Fulfill the electrical spec. after test
<b>Low temperature resistance</b>	-40±3°C for 500 hours	No apparent damage Fulfill the electrical spec. after test
<b>Vibration</b>	10 Hz/min~55 Hz/min~10 Hz/min vibration frequency with 1.5 mm amplitude for two hours in x, y, z directions	No apparent damage
<b>Drop shock</b>	Dropped onto printed circuit board from 100cm height three times in x, y, z directions. The terminals shall be protected.	No apparent damage
<b>Soldering heat resistance</b>	Preheating temperature : 150±10°C Preheating time : 1 to 2 minutes Solder bath temperature : 260±5°C Bathing time : 5±0.5 seconds	No apparent damage
<b>Bending test onto printed circuit board</b>	<p>Solder specimen LTCC components on the test printed circuit board (L: 100 x W: 40 x T: 1.6mm) in appended recommended PCB pattern.</p> <p>Apply the load in direction of the arrow until bending reaches 2 mm.</p>  <p>Unit: mm</p>	No apparent damage
<b>Solderability</b>	The dipped surface of the terminal shall be at least 75% covered with solder after dipped in solder bath of 235±5°C for 3±0.5 seconds.	No apparent damage

## STORAGE CONDITION

The temperature should be within 0 ~ 30°C and humidity should be less than 75% RH. The product should be used within 6 months from the time of delivery.



## RECOMMENDED REFLOW SOLDERING PROFILE

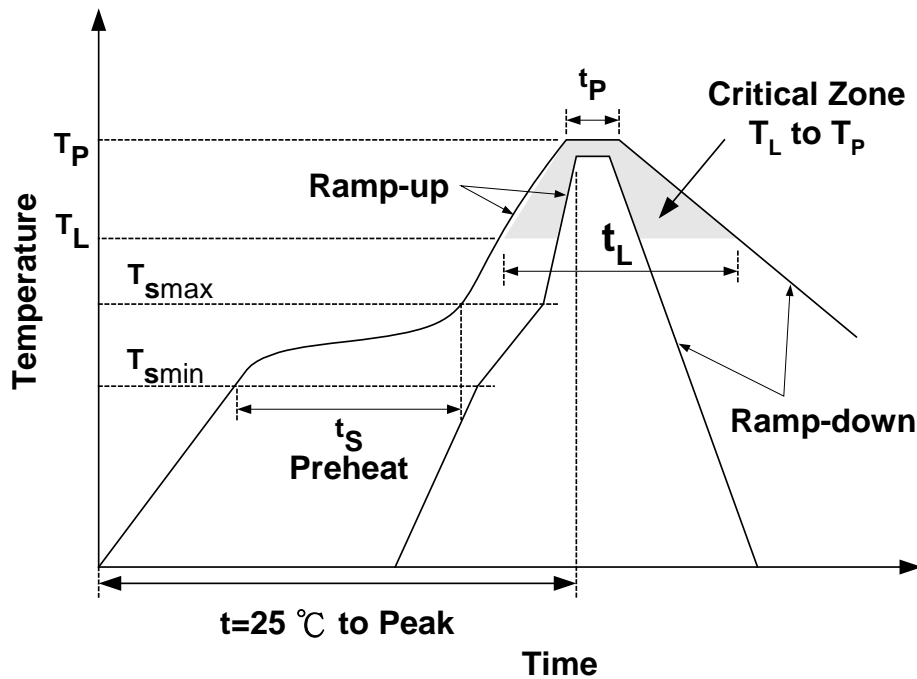

Profile Feature		Sn-Pb	Pb-Free
Preheat	$t_s$	60~120 seconds	60~180 seconds
	$T_{smin}$	100°C	150°C
	$T_{smax}$	150°C	200°C
Average ramp-up rate ( $T_{smax}$ to $T_P$ )		3°C/second max.	3°C/second max.
Time main above	Temperature ( $T_L$ )	183°C	217°C
	Time ( $t_L$ )	60~150 seconds	60~150 seconds
Peak temperature ( $T_P$ )		230°C	250~255°C
Time within 5°C of actual peak temperature ( $t_p$ )		10 seconds	10 seconds
Ramp-down rate		6°C/sec max.	6°C/sec max.
Time 25°C to peak temperature		6 minutes max.	8 minutes max.

## NOTES

The contents of this data sheet are subject to change without notice. Please confirm the specifications and delivery conditions when placing your order.