



FCC TEST REPORT

for

47 CFR Part 15 Subpart C

Equipment : Pocket PC (PDA)
Trade Name : My Guide
Model No. : 7500XL
FCC ID : P4Q-A7500XL
Filing Type : Certification
Applicant : **Mitac International Corporation**
6th FL., NO. 187, TIDING BLVD., SEC. 2, TAIPEI, TAIWAN, R.O.C.

- The test result refers exclusively to the test presented test model / sample.
- Without written approval of SPORTON International Inc., the test report shall not be reproduced except in full.
- **Certificate or Test Report must not be used by the applicant to claim the product in this test report endorsement by NVLAP or any agency of U.S. government.**
- The data shown in this test report were carried out on Mar. 22, 2006 at **Sporton International Inc. LAB.**
- Report No.: FR631101-01-A, Report Version: Rev. 01

Dr. Daniel Lee
EMC/SAR Director

SPORTON International Inc.

6F, No.106, Sec. 1, Hsin Tai Wu Rd., Hsi Chih, Taipei Hsien, Taiwan, R.O.C.

SPORTON International Inc.

TEL : 886-2-2696-2468

FAX : 886-2-2696-2255

Report Version: Rev. 01



Table of Contents

History of this test report.....ii

1. General Description of Equipment under Test..... 1

 1.1 Applicant1

 1.2 Manufacturer1

 1.3 Basic Description of Equipment under Test.....1

 1.4 Feature of Equipment under Test2

2 Test Configuration of Equipment under Test3

 2.1 Test Manner3

 2.2 Test Mode3

 2.3 Connection Diagram of Test System3

 2.4 Ancillary Equipment List.....4

3. RF Utility5

4. General Information of Test.....6

 4.1 Test Voltage6

 4.2 Standard for Methods of Measurement.....6

 4.3 Test in Compliance with6

 4.4 Frequency Range Investigated6

 4.5 Test Distance6

5. Test Data and Test Result.....7

 5.1 List of Measurements and Examinations7

 5.2 Band Edges Measurement.....8

 5.3 Hopping Channel Separation12

 5.4 Number of Hopping Frequency16

 5.5 Hopping Channel Bandwidth.....18

 5.6 Dwell Time of Each Frequency22

 5.7 Peak Output Power Measurement42

 5.8 Conducted Emission46

 5.9 Radiated Emission Measurement51

 5.10 Antenna Requirements67

6. List of Measuring Equipments Used68

7. Uncertainty Evaluation.....69

Appendix A. Photographs of EUT External

Appendix B. Photographs of EUT Internal

Appendix C. Photographs of Setup



1. General Description of Equipment under Test

1.1 Applicant

Mitac International Corporation

6th FL., NO. 187, TIDING BLVD., SEC. 2, TAIPEI, TAIWAN, R.O.C.

1.2 Manufacturer

Mitac Computer (KunShan) Co., Ltd.

No. 269, 2nd Road, Export Processing Zone, Changjiang South Road, KunShan, JiangSuprov. China

1.3 Basic Description of Equipment under Test

Equipment	: Pocket PC (PDA)
Trade Name	: My Guide
Model No.	: 7500XL
FCC ID	: P4Q-A7500XL
Power Supply Type	: Switching, From Battery 3.7V
AC Power Cord	: AC 120V, Wall-mount, 1.8 meter, 2pin
Battery	: E4MT111202B12
AC Charger	: Phihong, PSC05R-050
DC Charger	: Atech, ATPI-68HT0501-NC1.1



1.4 Feature of Equipment under Test

Product Feature & Specification			
1. Type of Modulation	GFSK		
2. Number of Channels	79 Channels		
3. Frequency Band	2.4GHz~2.4835GHz		
4. Carrier Frequency of each channel	2402MHz+n*1MHz, n=0~78		
5. Channel Spacing	1MHz		
6. Maximum Output Power to Antenna (Normal Condition)	2.69 dBm		
7. Type of Antenna Connector	N/A		
8. Antenna Type	Patch Antenna		
9. Antenna Gain	-1 dBi		
10. Function Type	Transmitter		Transceiver V
11. Power Rating (DC/AC Voltage) :	3.7V / 1200mA		

2 Test Configuration of Equipment under Test

2.1 Test Manner

- a. The EUT has been associated with peripherals pursuant to ANSI C63.4-2003 and configuration operated in a manner tended to maximize its emission characteristics in a typical application.
- b. For spurious emission below 1GHz, only one channel of each application was tested because it is not related to channel selection.
- c. The EUT is programmed to transmit signal continuously for all testings.
- d. Frequency range investigated: conduction 150 kHz to 30 MHz, radiation 30 MHz to 25000MHz.

2.2 Test Mode

Application	Bluetooth
Radiated Emission	Mode 1: Tx_CH00_2402 MHz Mode 2: Tx_CH39_2441 MHz Mode 3: Tx_CH78_2480 MHz
Conducted Emission	Mode 1: GPS Rx + Earphone + H Pattern + MPEG4 + BT Link + AC Charger Mode 2: GPS Rx + Earphone + H Pattern + MPEG4 + BT Link + USB Link

2.3 Connection Diagram of Test System

Radiated Emission

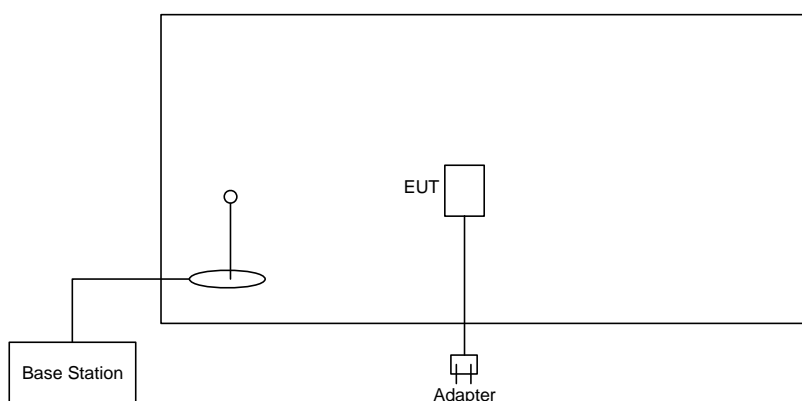

Conducted Emission

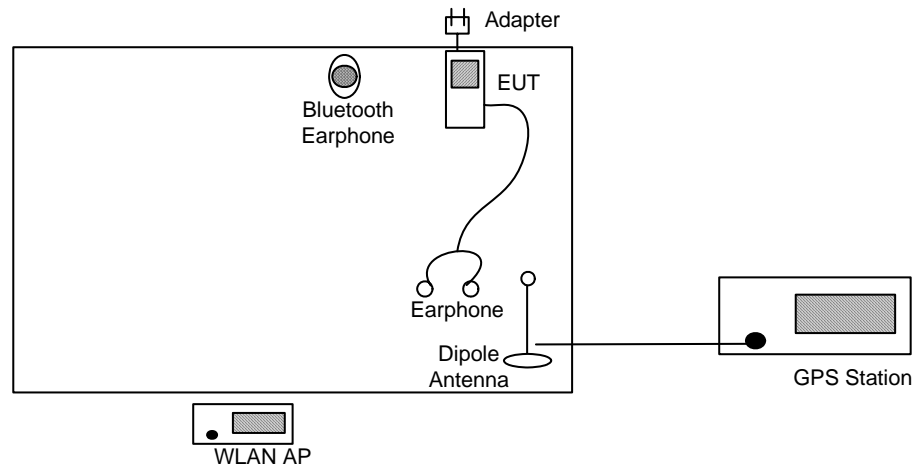

2.4 Ancillary Equipment List

Item	Asset	Trade Name	Model Name	Power Cord
1.	Adapter	PHIHONG	PSC05R-050	AC 100-240V
2.	Base Station	R&S	CMU200	AC 100-240V
3.	Dipole Antenna	Sporton	N/A	N/A
4.	Bluetooth Earphone	Free Style	JD-100	N/A
5.	GPS Station	T&H	GP-50	AC 100-240V
6.	Earphone	N/A	N/A	N/A



3. RF Utility

The programmed RF Utility is installed in EUT to provide channel selection, power level, data rate and the application type. RF Utility can send transmitting signal for all testings.



4. General Information of Test

Test Site Location : No. 52, Hwa Ya 1st Rd., Hwa Ya Technology Park,
Kwei-Shan Hsiang, Tao Yuan Hsien, Taiwan, R.O.C.
TEL : 886-3-327-3456
FAX : 886-3-318-0055
Test Site No : CO01-HY, 03CH06-HY

4.1 Test Voltage

120V/ 60Hz

4.2 Standard for Methods of Measurement

ANSI C63.4-2003

4.3 Test in Compliance with

47 CFR Part 15 Subpart C

4.4 Frequency Range Investigated

a. Radiation: from 30 MHz to 25000 MHz

4.5 Test Distance

The test distance of radiated emission from antenna to EUT is 3 m.



5. Test Data and Test Result

5.1 List of Measurements and Examinations

The Emission Mode: Bluetooth

FCC Rule	Description of Test	Result
15.207	Conducted Emission	Pass
<u>15.247(a)(1)</u>	Hopping Channel Bandwidth	Pass
<u>15.247(a)(1)</u>	Hopping Channel Separation	Pass
<u>15.247(a)(1)(iii)</u>	Number of Hopping Frequency Used	Pass
<u>15.247(a)(1)(iii)</u>	Dwell Time of Each Frequency	Pass
<u>15.247(b)</u>	Output Power	Pass
15.247(c)	100kHz Bandwidth of Frequency Band Edges	Pass
15.209(a)	Radiated Emission	Pass
<u>15.203</u> 15.247(b)(4)	Antenna Requirement	Pass



5.2 Band Edges Measurement

5.2.1 Measuring Instruments :

As described in chapter 6 of this test report.

5.2.2 Test Procedure :

1. The transmitter output was connected to the spectrum analyzer via a low lose cable.
2. Set both RBW and VBW of spectrum analyzer to 100kHz with suitable frequency span including 100 kHz bandwidth from band edge.
3. The band edges was measured and recorded.

5.2.3 Test Result :

- Application Type : BT
- Temperature : 24°C
- Relative Humidity : 52%
- Test Enginner : Andy

- Test Result in BT lower band (Channel 00) : PASS
- Test Result in BT higher band (Channel 78) : PASS

5.2.4 Note on Band Edge Emission :

➤Bluetooth

CH00 (Horizontal)

Frequency (MHz)	Level (dBuV/m)	Over Limit (dB)	Limit Line (dBuV/m)	Read Level (dBuV)	Antenna Factor (dB)	Cable Loss (dB)	Preamp Factor (dB)	Ant Pos (cm)	Table Pos (deg)	Remark
2344.00	50.60	-23.40	74.00	51.30	30.52	35.42	4.20	100	0	Peak
2344.00	39.40	-14.60	54.00	40.10	30.52	35.42	4.20	100	64	Average

CH00 (Vertical)

Frequency (MHz)	Level (dBuV/m)	Over Limit (dB)	Limit Line (dBuV/m)	Read Level (dBuV)	Antenna Factor (dB)	Cable Loss (dB)	Preamp Factor (dB)	Ant Pos (cm)	Table Pos (deg)	Remark
2358.00	50.49	-23.51	74.00	51.20	30.51	35.42	4.20	100	360	Peak
2358.00	39.43	-14.57	54.00	40.14	30.51	35.42	4.20	100	280	Average



CH78 (Horizontal)

Frequency (MHz)	Level (dBuV/m)	Over Limit (dB)	Limit Line (dBuV/m)	Read Level (dBuV)	Antenna Factor (dB)	Cable Loss (dB)	Preamp Factor (dB)	Ant Pos (cm)	Table Pos (deg)	Remark
2483.50	66.45	-7.55	74.00	67.19	30.41	35.51	4.36	100	4	Peak
2483.50	43.45	-10.55	54.00	44.19	30.41	35.51	4.36	100	25	Average

CH78 (Vertical)

Frequency (MHz)	Level (dBuV/m)	Over Limit (dB)	Limit Line (dBuV/m)	Read Level (dBuV)	Antenna Factor (dB)	Cable Loss (dB)	Preamp Factor (dB)	Ant Pos (cm)	Table Pos (deg)	Remark
2483.50	65.43	-8.57	74.00	66.17	30.41	35.51	4.36	100	333	Peak
2483.50	43.92	-10.08	54.00	44.66	30.41	35.51	4.36	100	260	Average



CH78



Ref 9 dBm *Att 10 dB *RBW 100 kHz Marker 1 [T1] -42.43 dBm
*VBW 100 kHz *SWT 500 ms 2.484400000 GHz

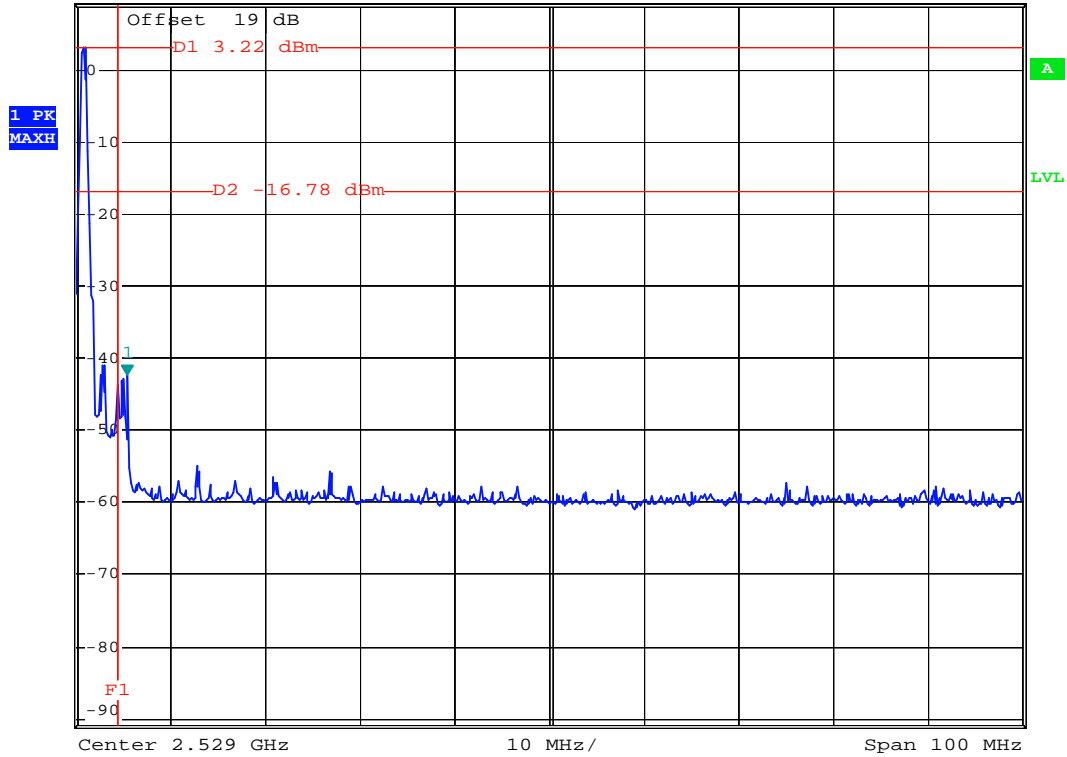

Date: 22.MAR.2006 09:49:11

5.3 Hopping Channel Separation

5.3.1 Measuring Instruments :

As described in chapter 9 of this test report.

5.3.2 Test Procedure :

1. The output of EUT was connected to the spectrum analyzer by a low loss cable..
2. Set RBW of spectrum analyzer to 100kHz and VBW to 100kHz.
3. The Hopping Channel Separation is defined as the channel is separated with the next channel.

5.3.3 Test Setup Layout :

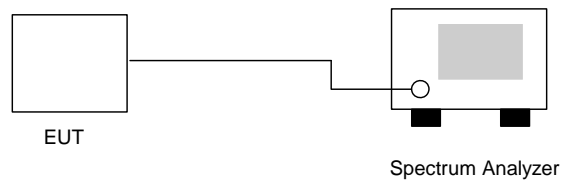

5.3.4 Test Result : The spectrum analyzer plots are attached as below

- Application Type : BT
- Temperature : 24°C
- Relative Humidity : 52%
- Test Enginner : Andy

Channel	Carrier Frequency		Limits (MHz)	Plot Ref. No.
	Frequency (MHz)	Separation (MHz)		
00	2402	1.000	0.878	Mode 1
39	2441	1.000	0.874	Mode 2
78	2480	1.004	0.880	Mode 3

Note: Limits =25kHz or the 20dB bandwidth of the hopping channel, which ever is greater



5.3.5 Hopping Channel Separation

Mode 1



Ref 9 dBm * Att 10 dB * RBW 30 kHz Delta 2 [T1]
* VBW 100 kHz 0.30 dB
* SWT 500 ms 1.000000000 MHz

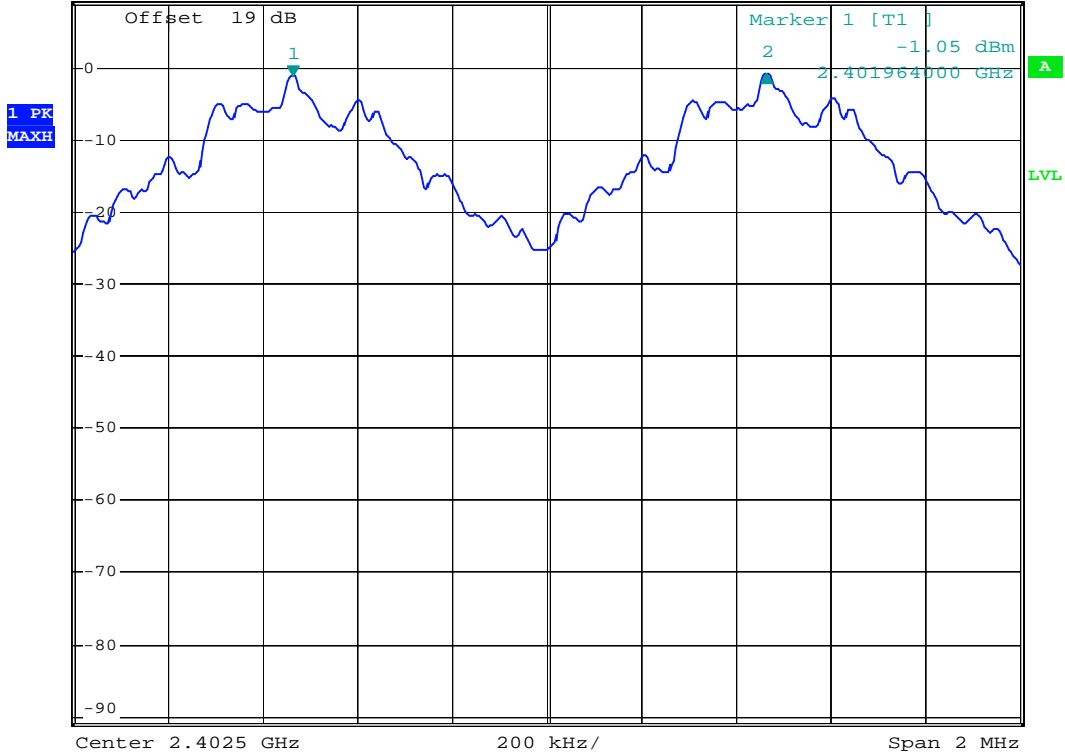

Date: 22.MAR.2006 09:25:47



Mode 2



*RBW 30 kHz Delta 2 [T1]
*VBW 100 kHz 0.07 dB
*SWT 500 ms 1.000000000 MHz

Ref 9 dBm

*Att 10 dB

1. PR
MAXH

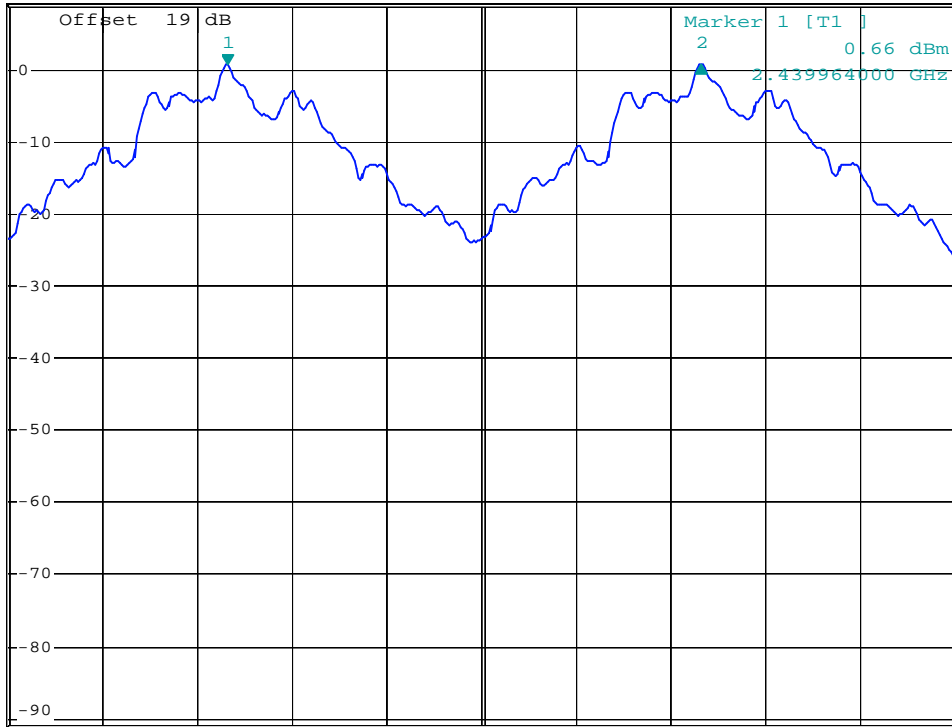

Center 2.4405 GHz 200 kHz/ Span 2 MHz

Date: 22.MAR.2006 09:26:15



Mode 3



Ref 9 dBm *Att 10 dB *RBW 30 kHz Delta 2 [T1]
*VBW 100 kHz 0.00 dB
*SWT 500 ms 1.004000000 MHz

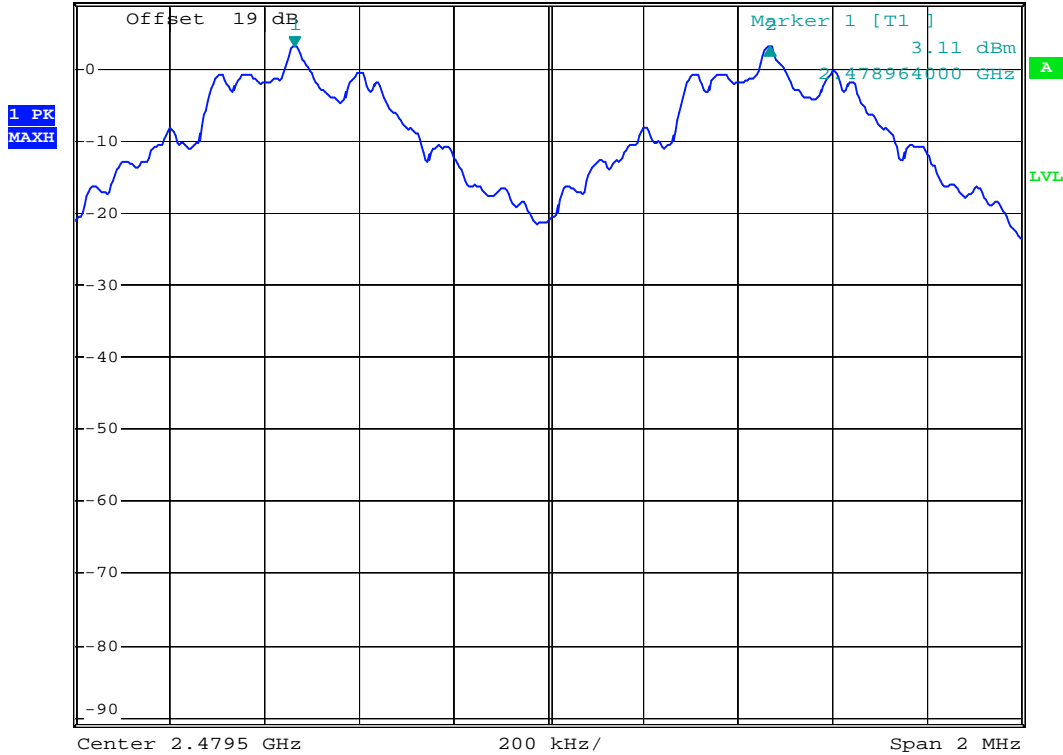

Date: 22.MAR.2006 09:49:46

5.4 Number of Hopping Frequency

5.4.1 Measuring Instruments :

As described in chapter 9 of this test report.

5.4.2 Test Procedure :

1. The output of EUT was connected to the spectrum analyzer by a low loss cable.
2. Set RBW of spectrum analyzer to 100kHz and VBW to 100kHz.
3. The number of hopping frequency used is defined as the device has the numbers of total channel.

5.4.3 Test Setup Layout :

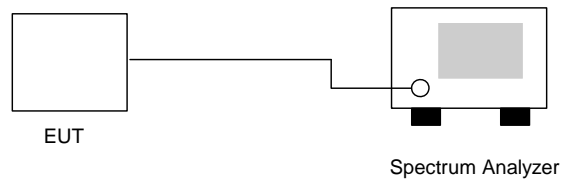

5.4.4 Test Result : See spectrum analyzer plots below

- Application Type : BT
- Temperature : 24°C,
- Relative Humidity : 52%
- Test Enginner : Andy

Number of Hopping Frequency (Channel)	Limits (Channel)
79	15

5.5 Hopping Channel Bandwidth

5.5.1 Measuring Instruments :

As described in chapter 9 of this test report.

5.5.2 Test Procedure :

1. The transmitter output was connected to the spectrum analyzer by a low loss cable.
2. Set RBW of spectrum analyzer to 30kHz and VBW to 300kHz.
3. The Hopping Channel bandwidth is defined as the total spectrum the power of which is higher than peak power minus 20 dB.

5.5.3 Test Setup Layout :

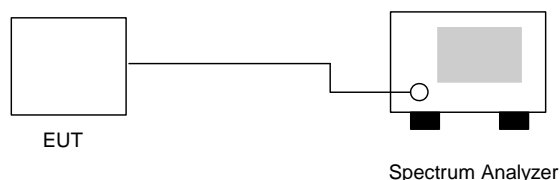

5.5.4 Test Result : See spectrum analyzer plots below

- Application Type : BT
- Temperature : 24°C,
- Relative Humidity : 52%
- Test Enginner : Andy

Channel	Frequency (MHz)	Hopping Channel Bandwidth (MHz)	Limits (MHz)	Plot Ref. No.
00	2402	0.878	1.000	Mode 1
39	2441	0.874	1.000	Mode 2
78	2480	0.880	1.000	Mode 3



5.5.5 Hopping Channel Bandwidth

Mode 1



Ref 9 dBm *Att 10 dB *RBW 30 kHz Delta 2 [T1]
 *VBW 300 kHz -0.08 dB
 *SWT 500 ms 878.00000000 kHz

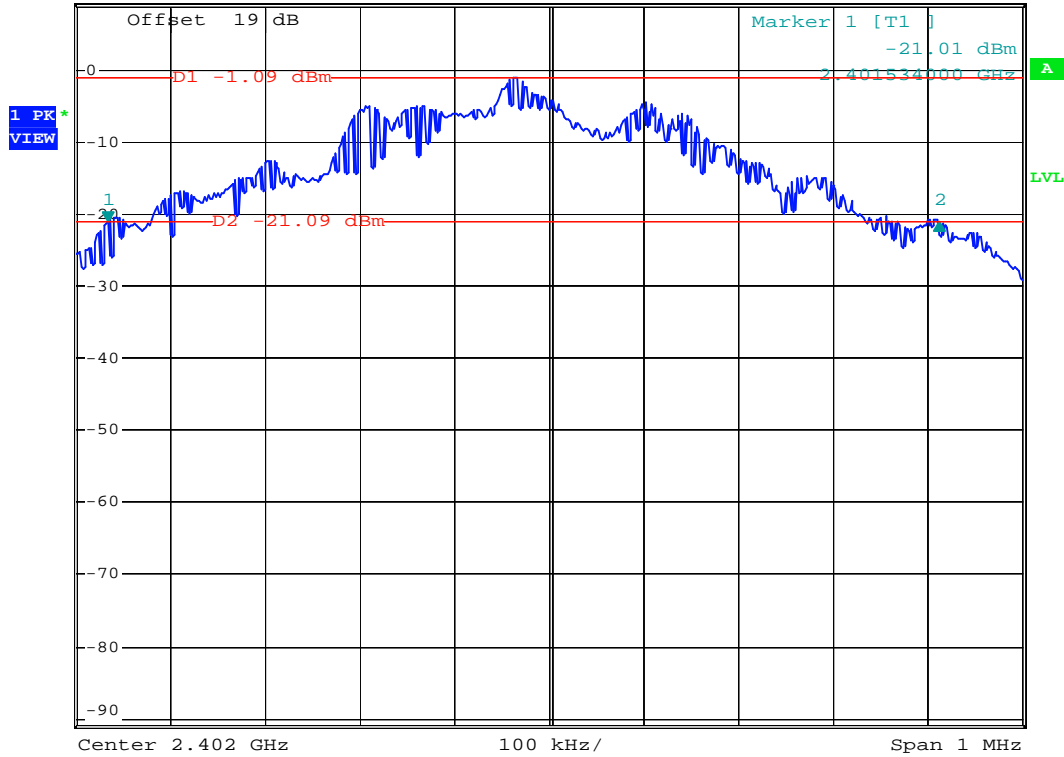

Date: 22.MAR.2006 09:24:34



Mode 2



*RBW 30 kHz Delta 2 [T1]
 *VBW 300 kHz -0.17 dB
 *SWT 500 ms 874.00000000 kHz

Ref 9 dBm

*Att 10 dB

1 PR
VIEW

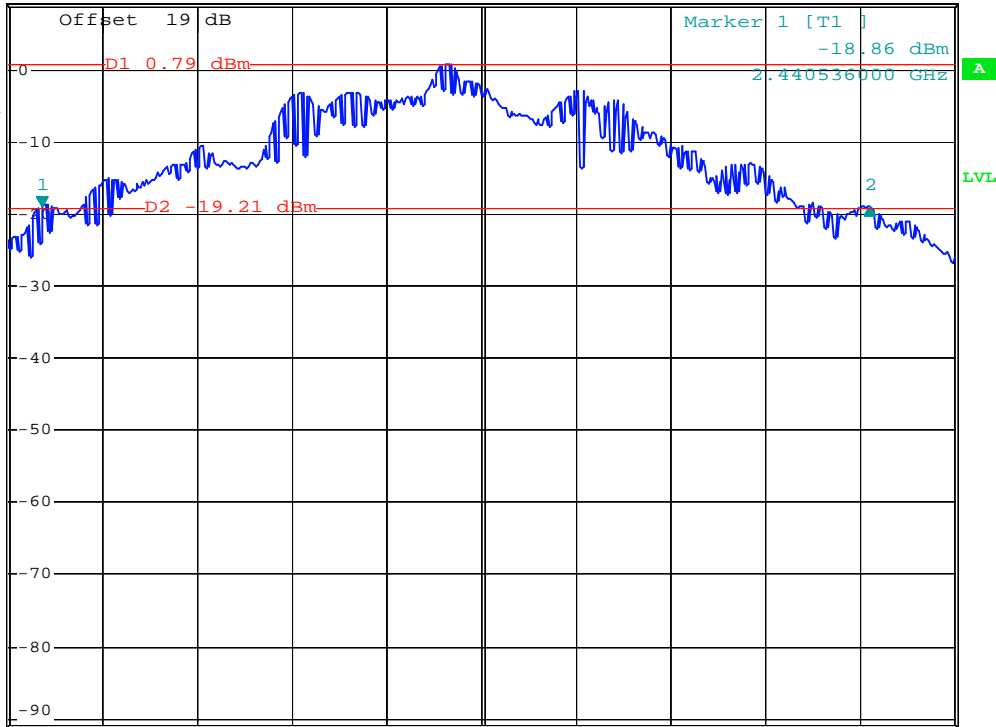

Center 2.441 GHz 100 kHz/ Span 1 MHz

Date: 22.MAR.2006 09:27:06



Mode 3

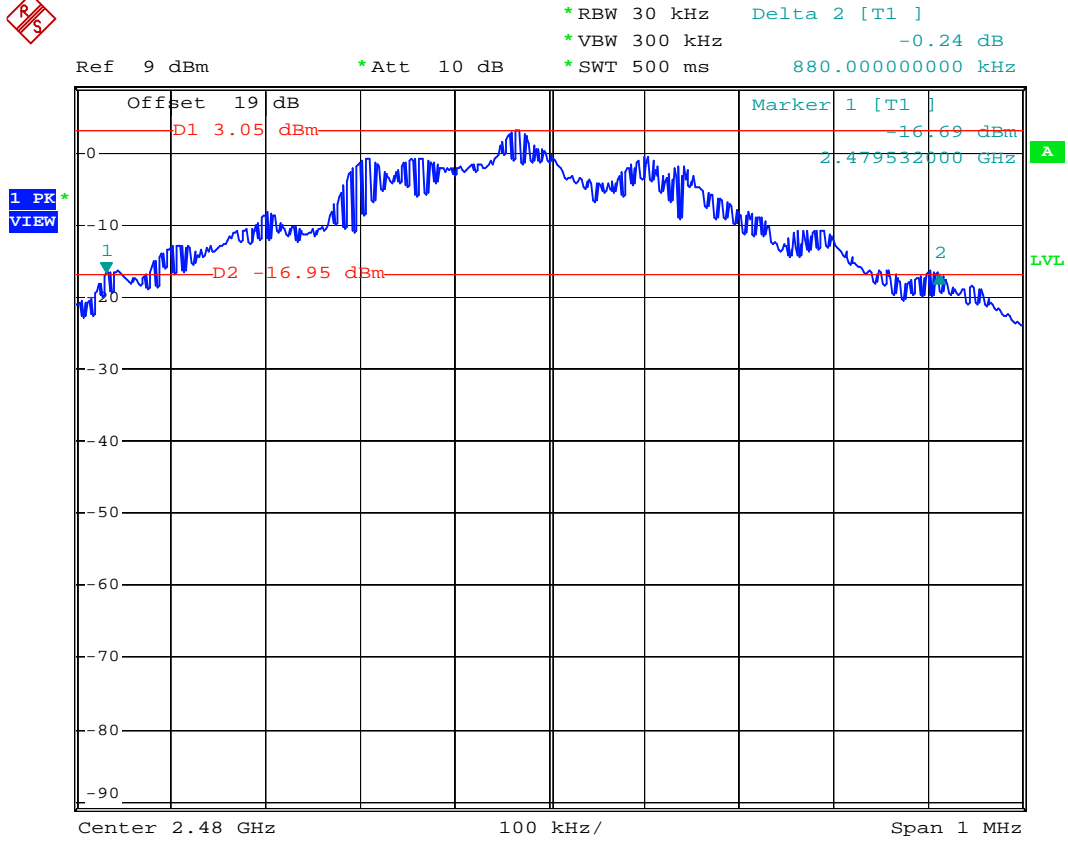

Date: 22.MAR.2006 09:48:24

5.6 Dwell Time of Each Frequency

5.6.1 Measuring Instruments :

As described in chapter 9 of this test report.

5.6.2 Test Procedure :

1. The transmitter output was connected to the spectrum analyzer by a low loss cable.
2. Set RBW of spectrum analyzer to 1MHz and VBW to 1MHz.
3. Set the center frequency on any frequency would be measure and set the frequency span to zero span.
4. The calculate $= 79 * 0.4 * (1600/79) * t$ (t = the time duration of one single pulse)

5.6.3 Test Setup Layout :

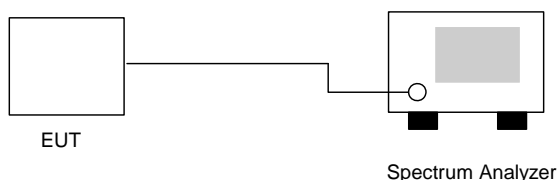

5.6.4 Test Result : See spectrum analyzer plots below

- Application Type : BT
- Temperature : 24°C
- Relative Humidity : 52%
- Test Enginner : Andy

Ch00

Package Mode	Average Hopping Channel	Package Transfer Time (us)	Dwell Time (s)	Limit (s)
DH1	7.3	548	0.126	0.4
DH3	4.2	1818	0.241	0.4
DH5	3.5	3078	0.340	0.4



CH39

Package Mode	Average Hopping Channel	Package Transfer Time (us)	Dwell Time (s)	Limit (s)
DH1	8.2	554	0.144	0.4
DH3	5.1	1818	0.293	0.4
DH5	3.2	3078	0.311	0.4

CH78

Package Mode	Average Hopping Channel	Package Transfer Time (us)	Dwell Time (s)	Limit (s)
DH1	7.4	550	0.129	0.4
DH3	4.2	1820	0.242	0.4
DH5	3.7	3080	0.360	0.4

Remark:

1. Dwell Time=79(channels) x 0.4(s) x average hopping channel x package transfer time
2. 79channels come from the Hopping Channel number.
3. Average Hopping Channel = hops/sweep time
4. t: Package Transfer Time(us)



5.6.5 Dwell Time

DH1 (CH00)



RBW 1 MHz Delta 3 [T1]
*VBW 1 MHz 0.24 dB
Ref 9 dBm *Att 10 dB SWT 2 ms 1.260000 ms

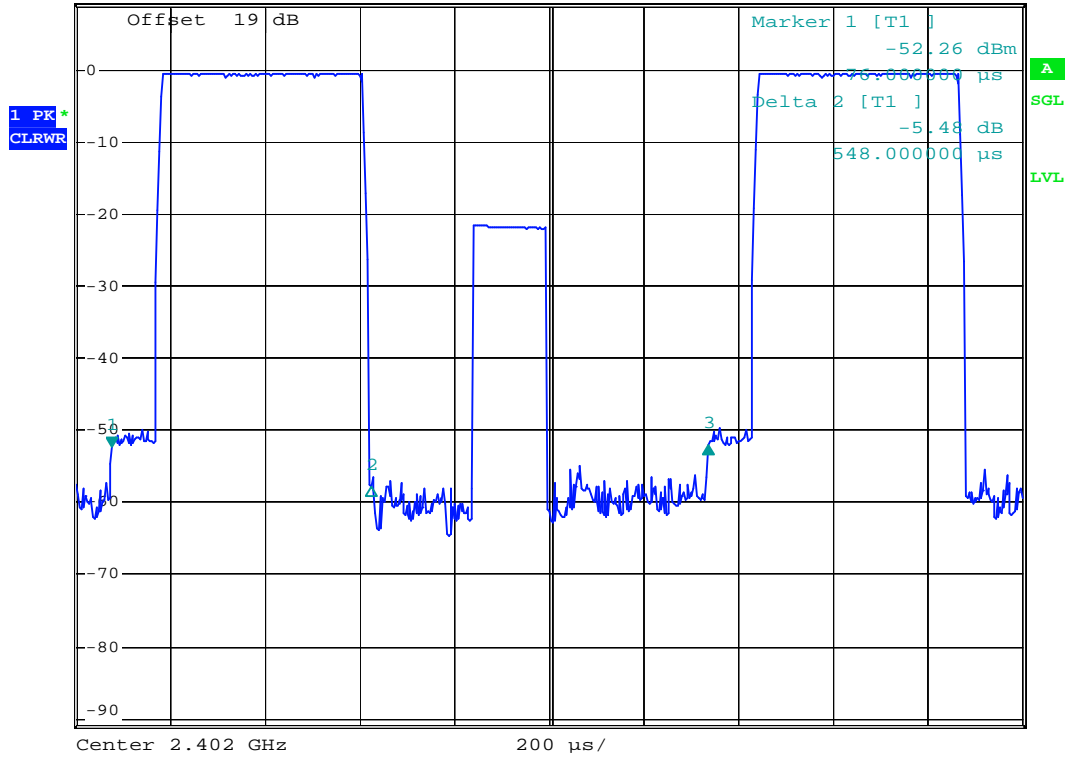

Date: 22.MAR.2006 09:39:02



Ref 9 dBm *Att 10 dB RBW 1 MHz
*VBW 1 MHz SWT 10 s

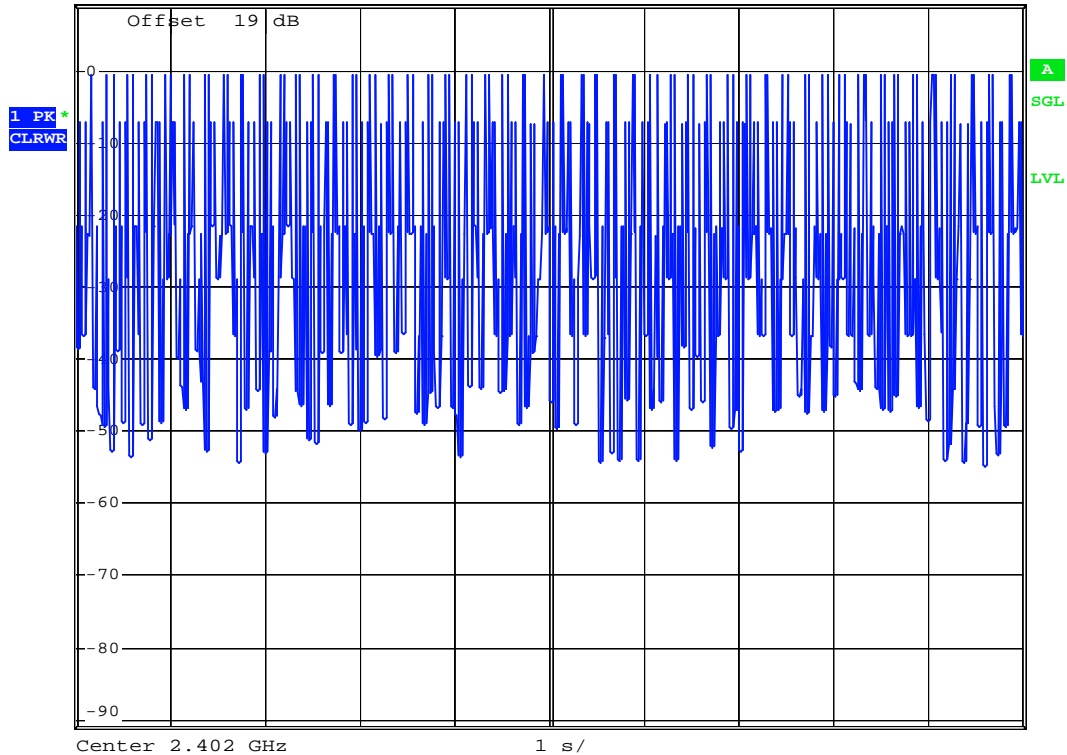

Date: 22.MAR.2006 09:47:15



DH1 (CH39)

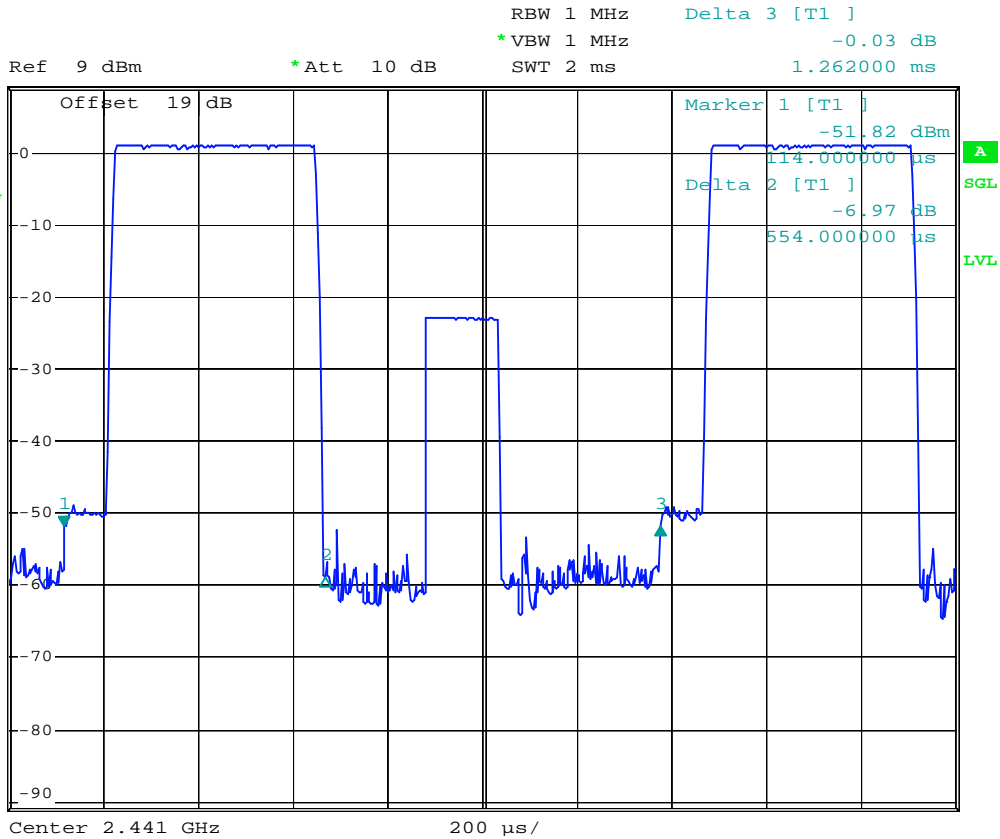

Date: 22.MAR.2006 09:41:44

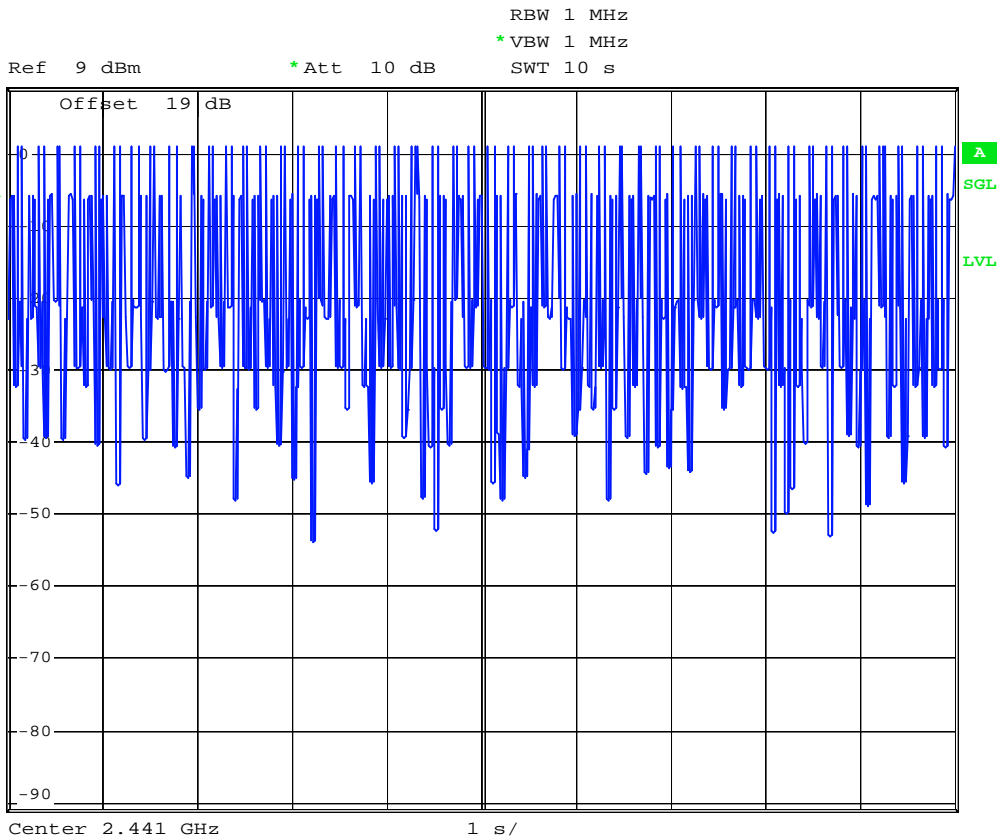

Date: 22.MAR.2006 09:46:53



DH1 (CH78)



RBW 1 MHz Delta 3 [T1]
*VBW 1 MHz 1.00 dB
SWT 2 ms 1.262000 ms
Ref 9 dBm *Att 10 dB

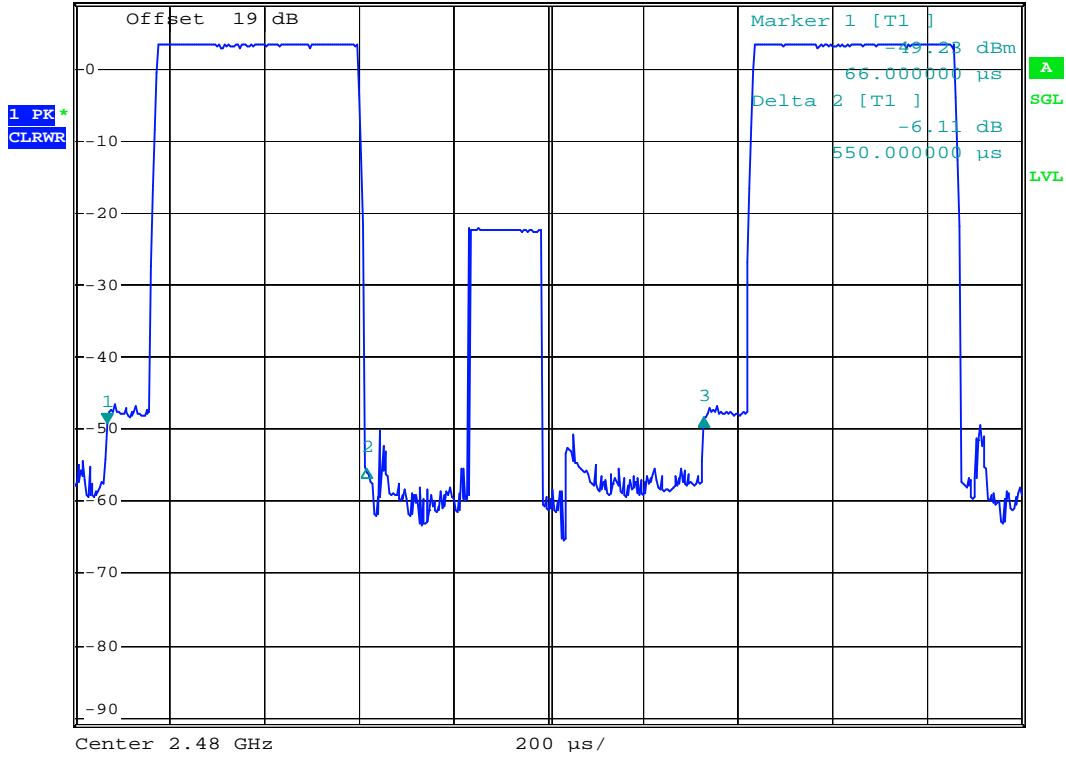

Date: 22.MAR.2006 09:42:13

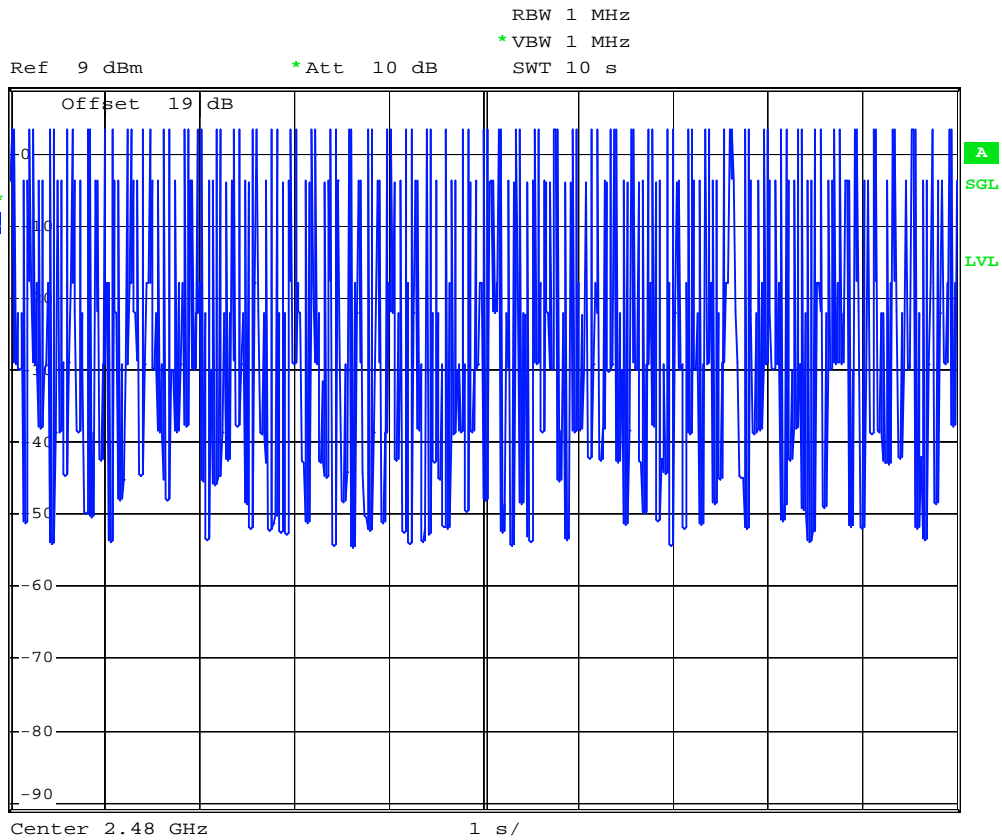

Date: 22.MAR.2006 09:46:28



DH3 (CH00)



RBW 1 MHz Delta 3 [T1]
*VBW 1 MHz -1.62 dB
Ref 9 dBm *Att 10 dB SWT 5 ms 2.500000 ms

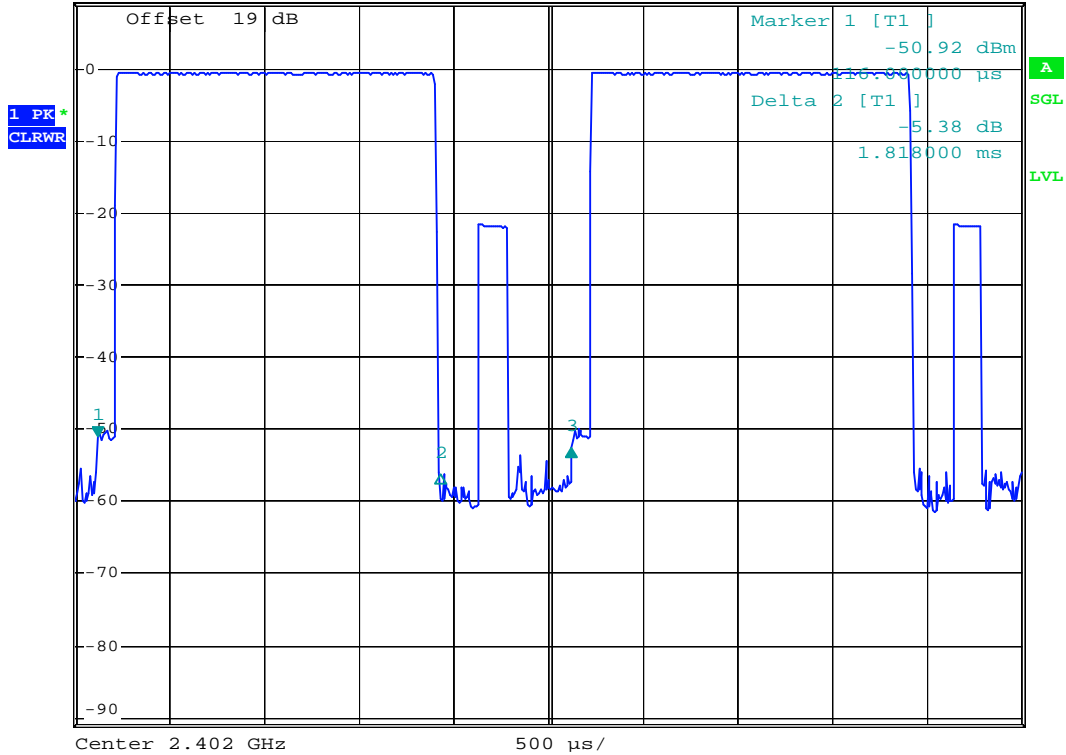

Date: 22.MAR.2006 09:39:32



Ref 9 dBm *Att 10 dB RBW 1 MHz
*VBW 1 MHz SWT 10 s

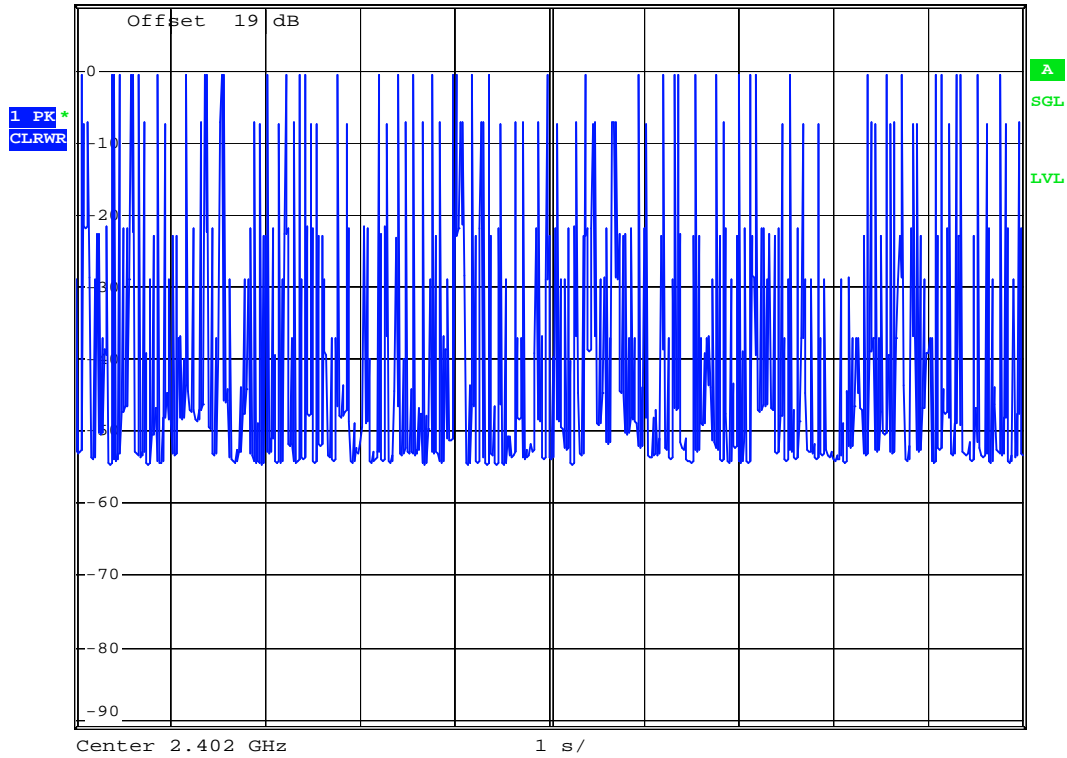

Date: 22.MAR.2006 09:45:10



DH3 (CH39)

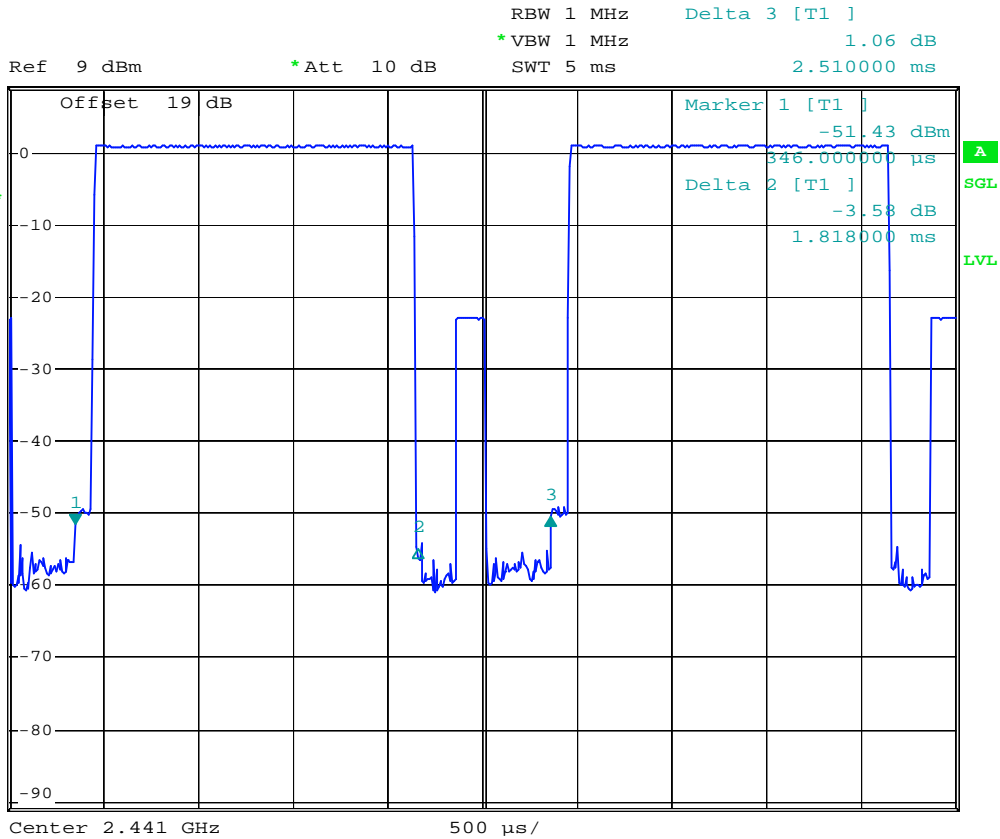

Date: 22.MAR.2006 09:41:08

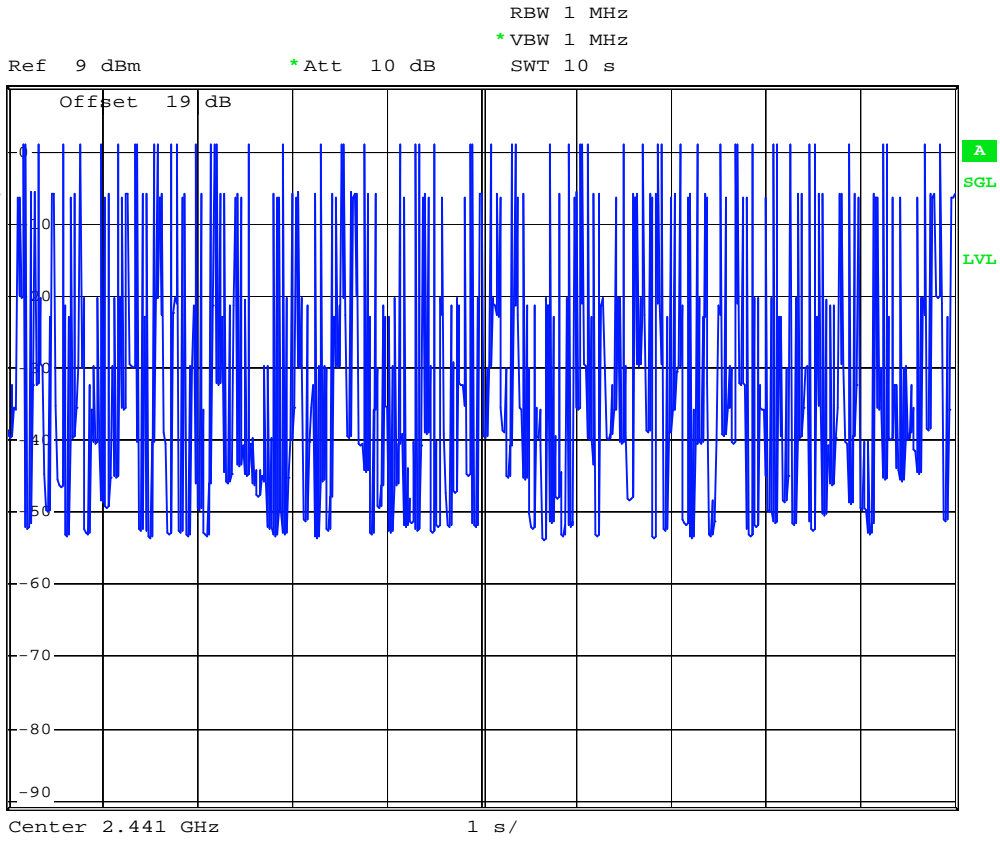

Date: 22.MAR.2006 09:45:31



DH3 (CH78)



RBW 1 MHz Delta 3 [T1]
 *VBW 1 MHz 1.48 dB
 Ref 9 dBm *Att 10 dB SWT 5 ms 2.512000 ms

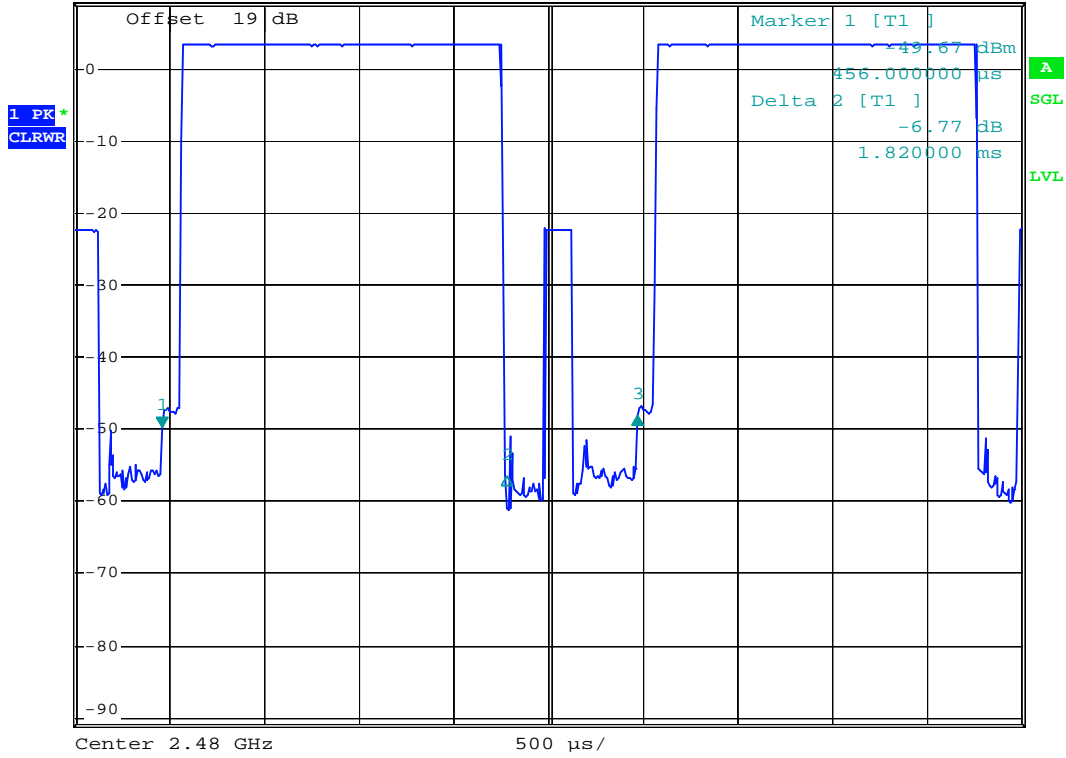

Date: 22.MAR.2006 09:42:43

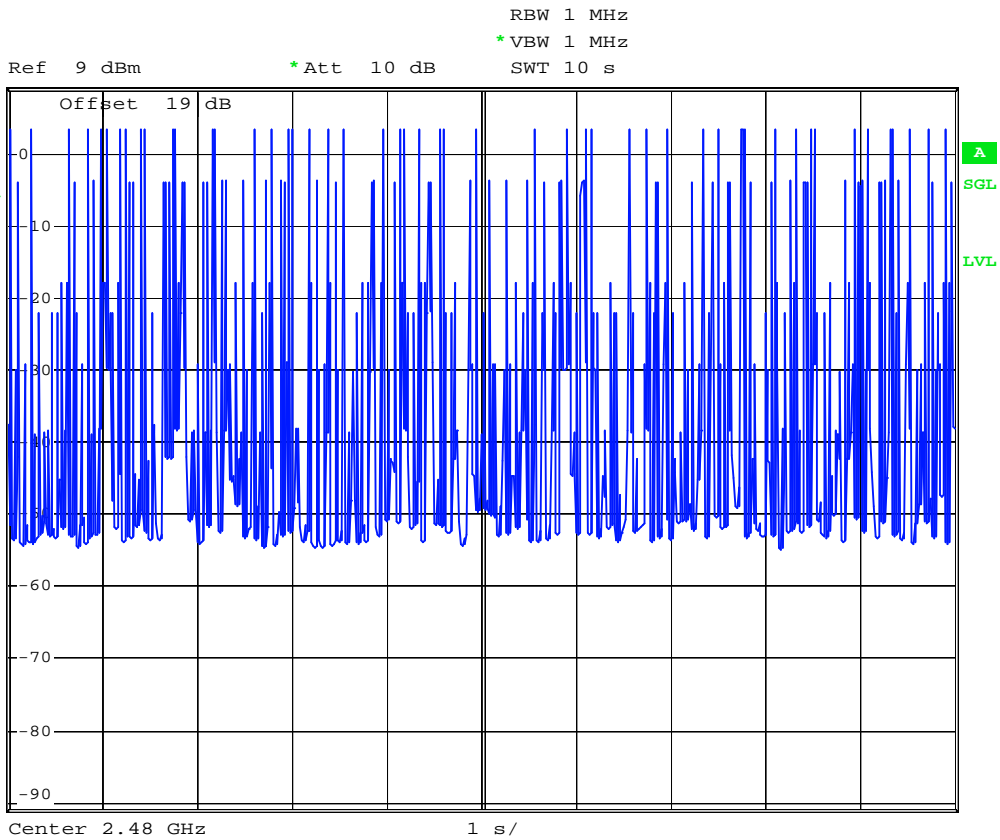

Date: 22.MAR.2006 09:46:03



DH5 (CH00)



RBW 1 MHz Delta 3 [T1]
 *VBW 1 MHz 0.74 dB
 Ref 9 dBm *Att 10 dB SWT 10 ms 3.780000 ms

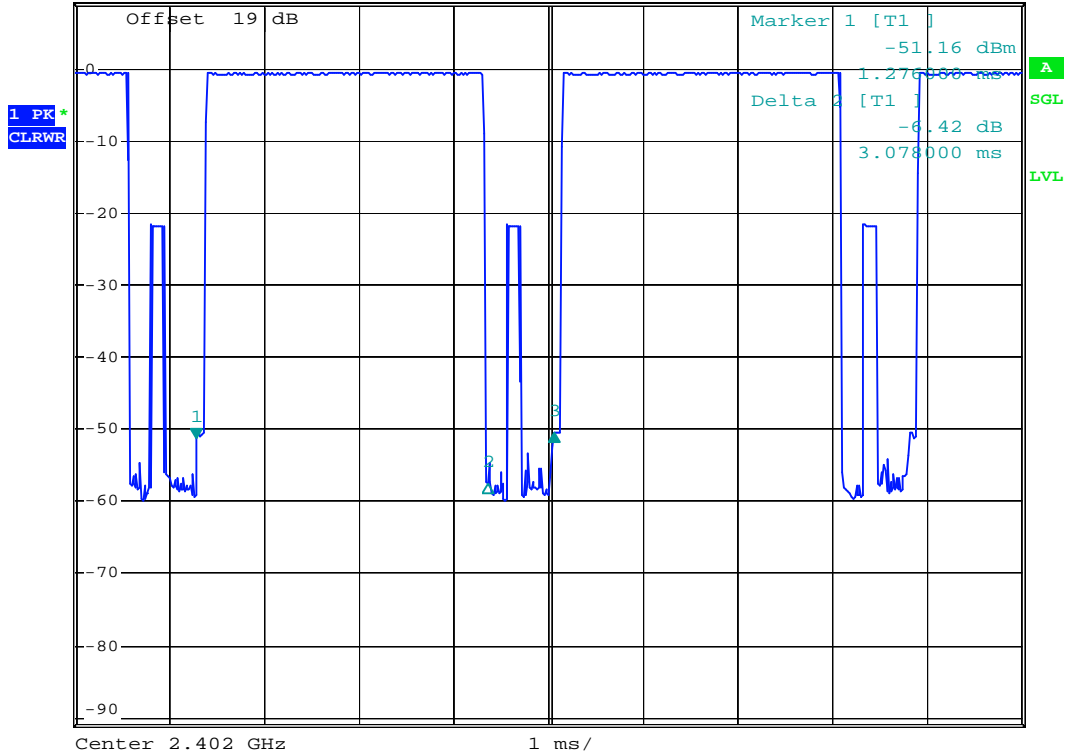

Date: 22.MAR.2006 09:39:59

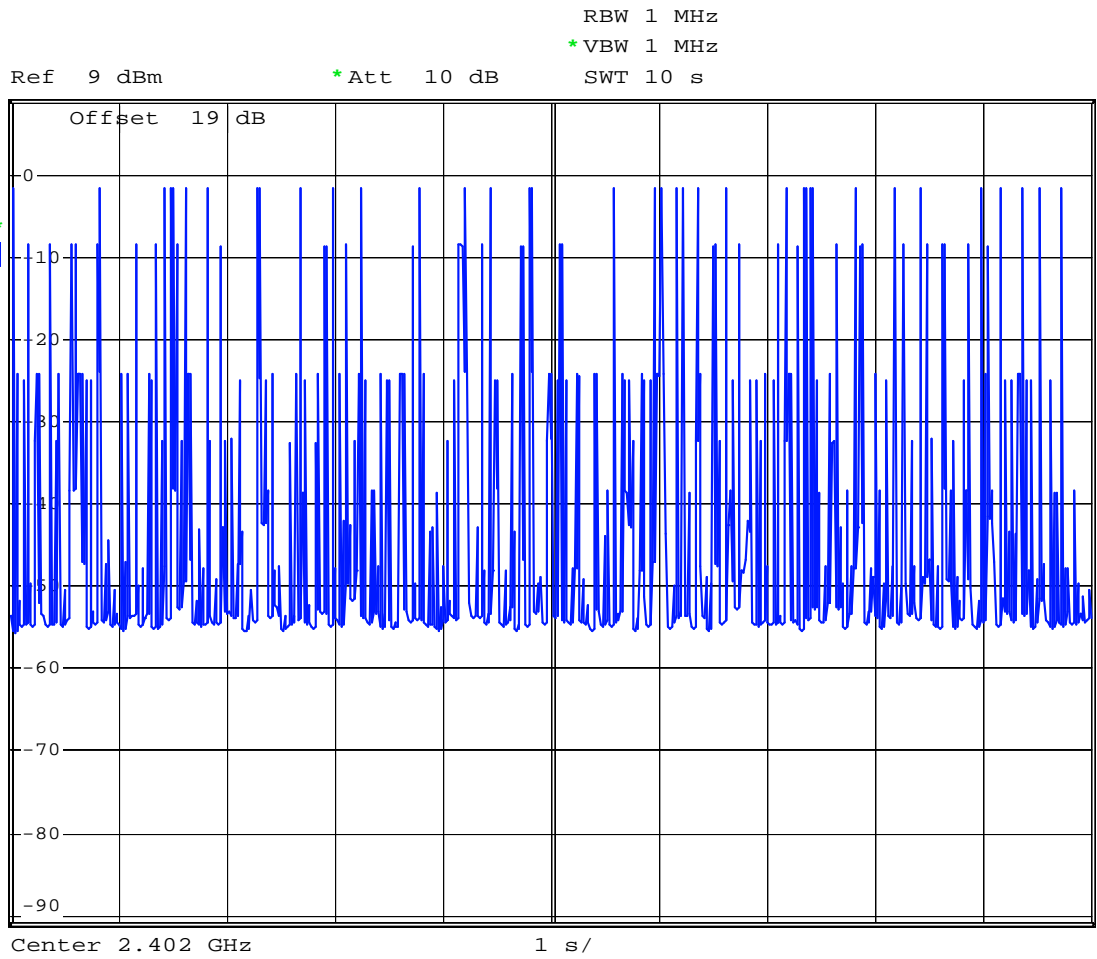

Date: 22.MAR.2006 16:09:32



DH5 (CH39)

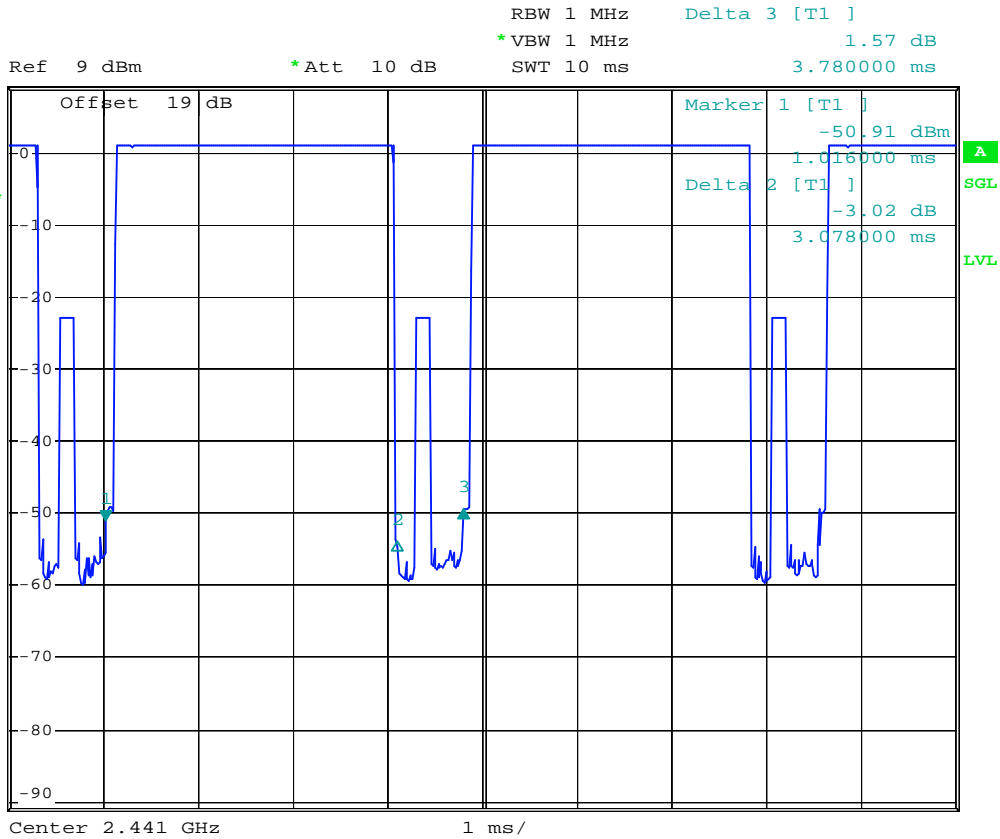

Date: 22.MAR.2006 09:40:35



RBW 1 MHz
*VBW 1 MHz

Ref 9 dBm *Att 10 dB SWT 10 s

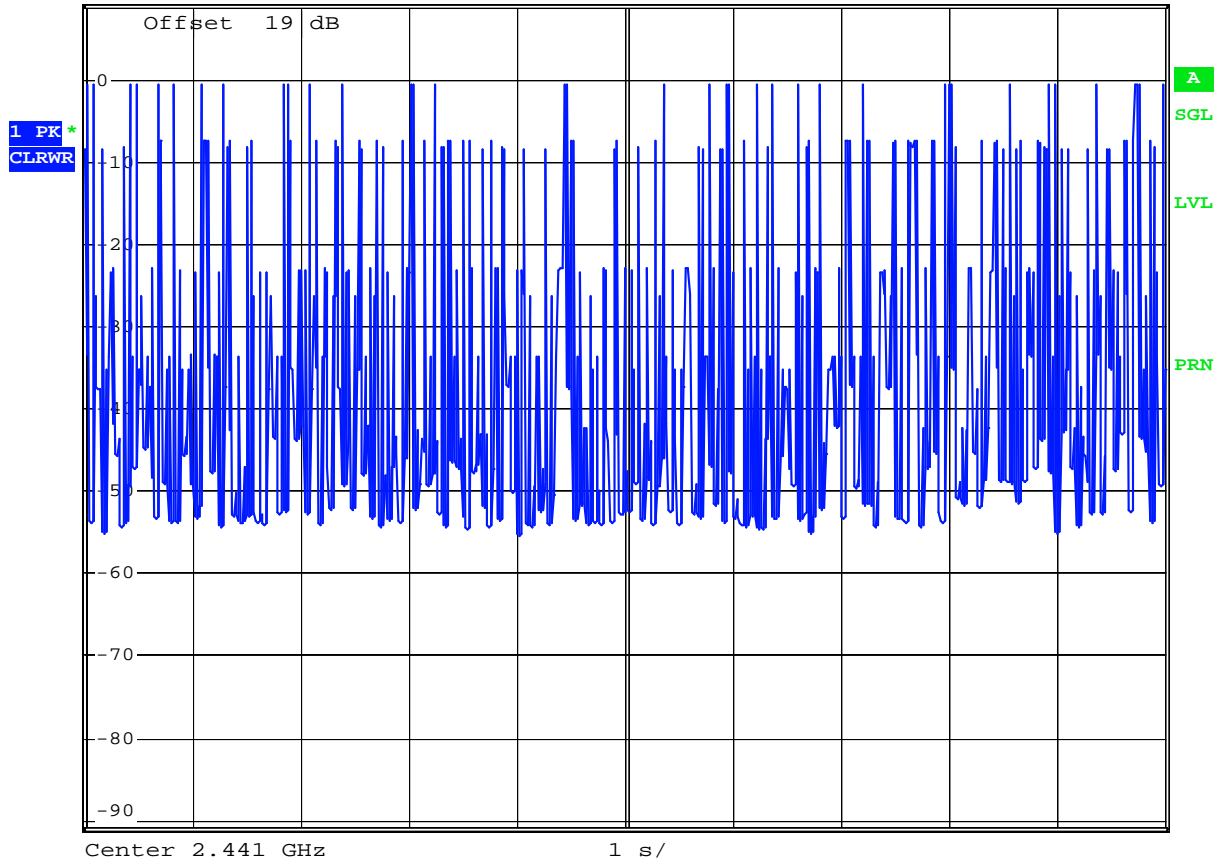

Date: 22.MAR.2006 16:11:27



DH5 (CH78)

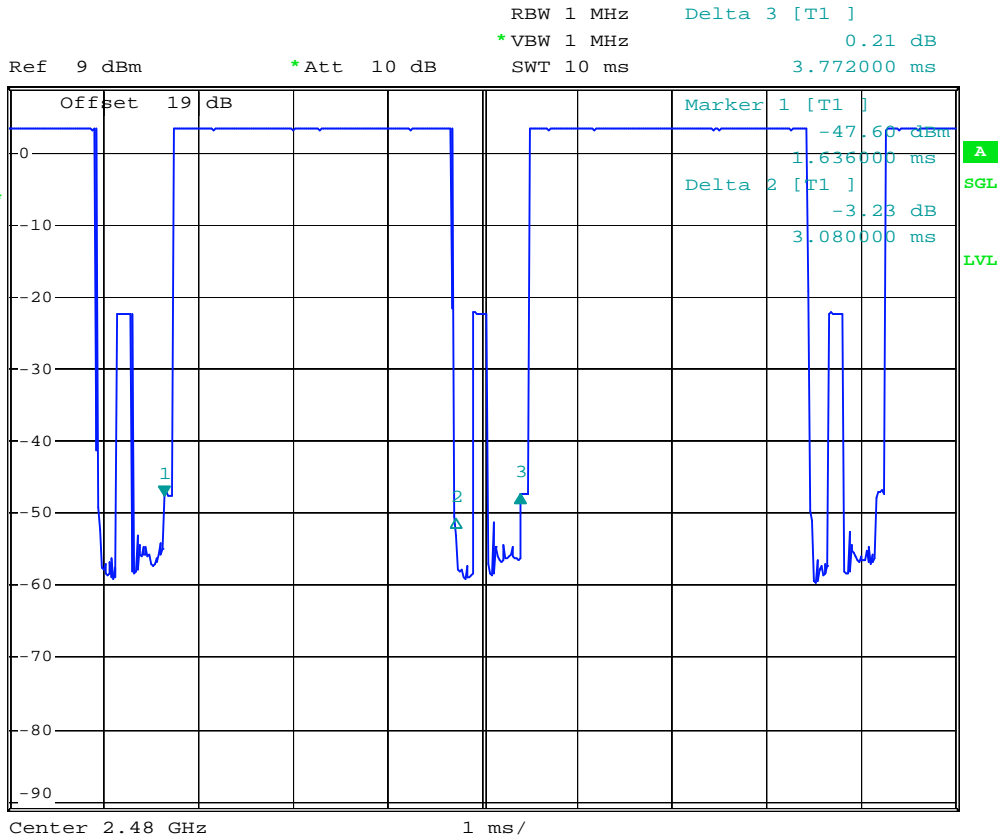

Date: 22.MAR.2006 09:43:18



Ref 9 dBm *Att 10 dB RBW 1 MHz Marker 1 [T1]
*VBW 1 MHz -51.96 dBm
SWT 10 s 2.000000 ms

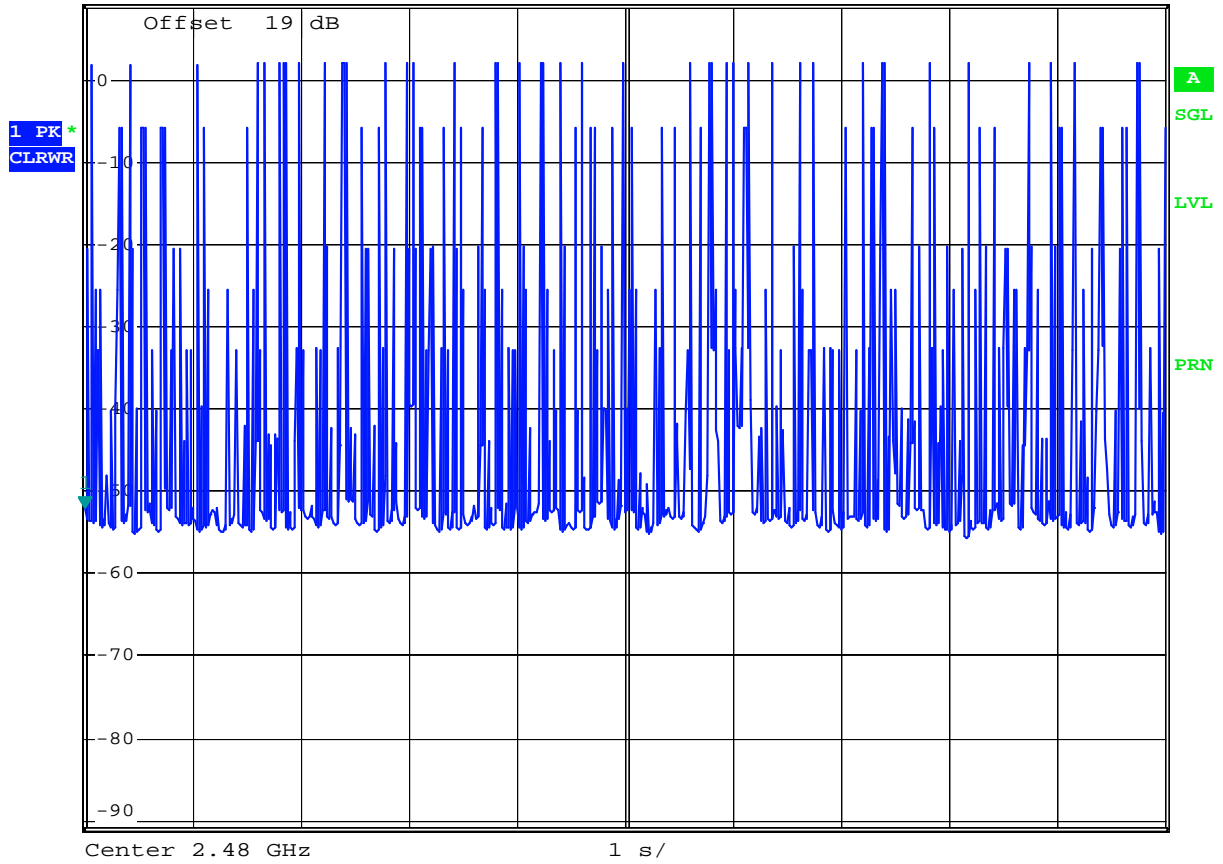

Date: 22.MAR.2006 16:04:14

5.7 Peak Output Power Measurement

5.7.1 Measuring Instruments :

As described in chapter 6 of this test report.

5.7.2 Test Procedure :

1. The antenna port (RF output) of the EUT was connected to the input (RF input) of a power meter for WLAN measurement. The power is equal to the reading level on power meter plus cable loss at the EUT antenna terminal.
2. The antenna port(RF output) of the EUT was connected to the input (RF input) of a spectrum analyzer for BT measurement. The cable loss has been offset before testing.

5.7.3 Test Setup Layout :

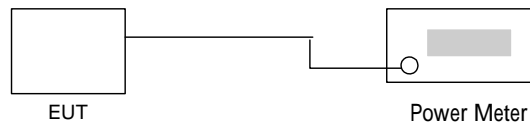

5.7.4 Test Result :

- Application Type : BT
- Temperature : 24°C
- Relative Humidity : 52 %
- Test Enginner : Andy

BT

Channel	Frequency (MHz)	Measured Output Power (dBm)	Limits (Watt/dBm)
00	2402	2.69	1W/30 dBm
39	2441	1.13	1W/30 dBm
78	2480	2.30	1W/30 dBm



5.7.5 Output Power

Mode 1: CH00 (2402MHz)



*RBW 3 MHz Marker 1 [T1]
*VBW 3 MHz 2.69 dBm
*SWT 500 ms 2.401860000 GHz

Ref 9 dBm

*Att 10 dB

1 PK
MAXH

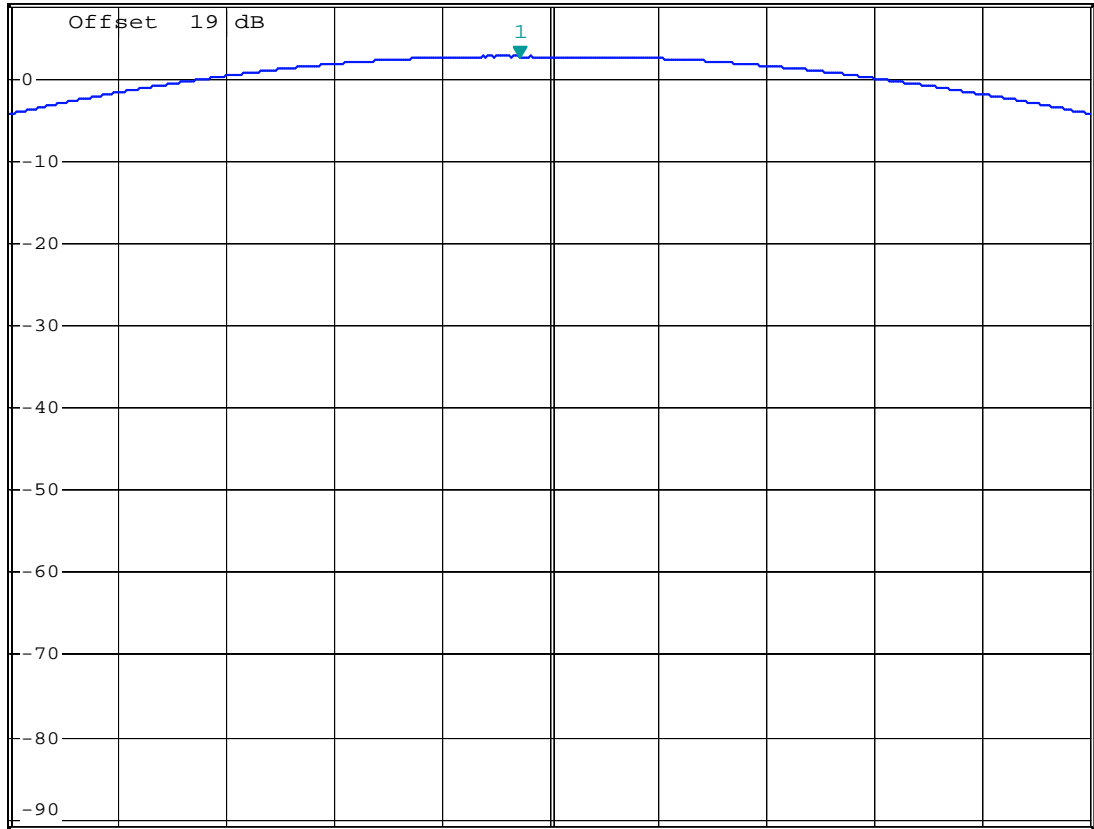

Date: 22.MAR.2006 16:37:55



Mode 2: CH39 (2441MHz)



Ref 9 dBm *Att 10 dB *RBW 3 MHz Marker 1 [T1] *VBW 3 MHz 1.13 dBm
*SWT 500 ms 2.44082000 GHz

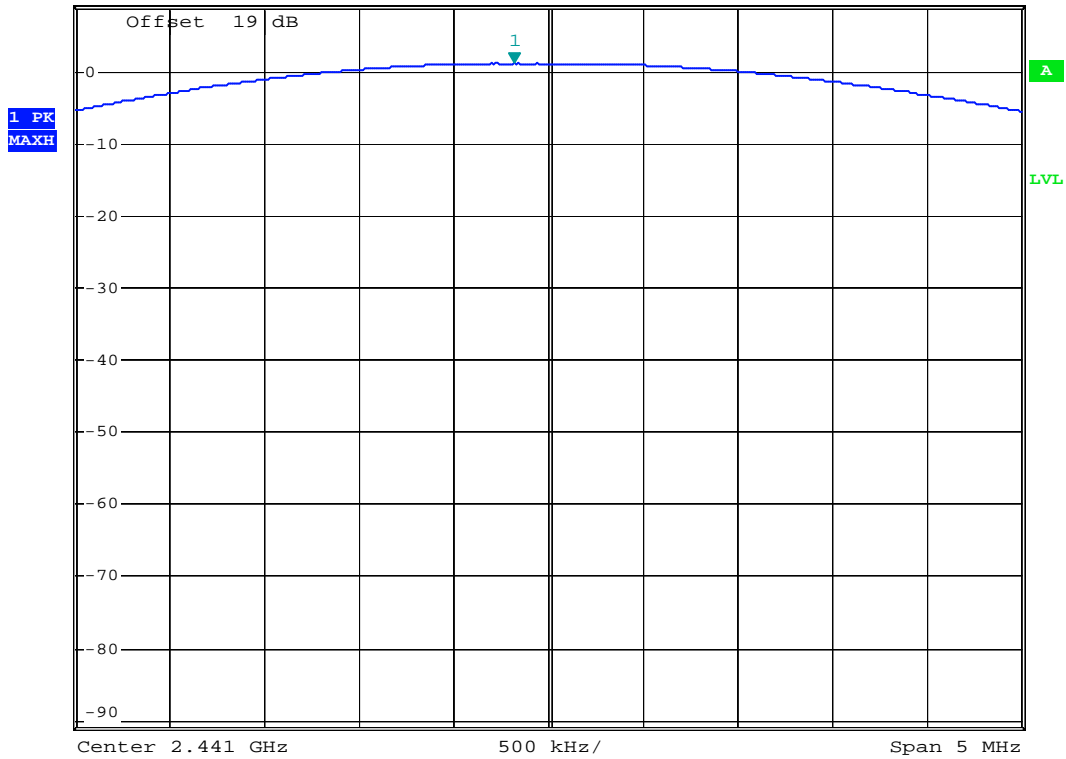

Date: 22.MAR.2006 09:27:30



Mode 3: CH78 (2480MHz)



*RBW 3 MHz Marker 1 [T1]
*VBW 3 MHz 2.30 dBm
*SWT 500 ms 2.47980000 GHz

Ref 9 dBm

*Att 10 dB

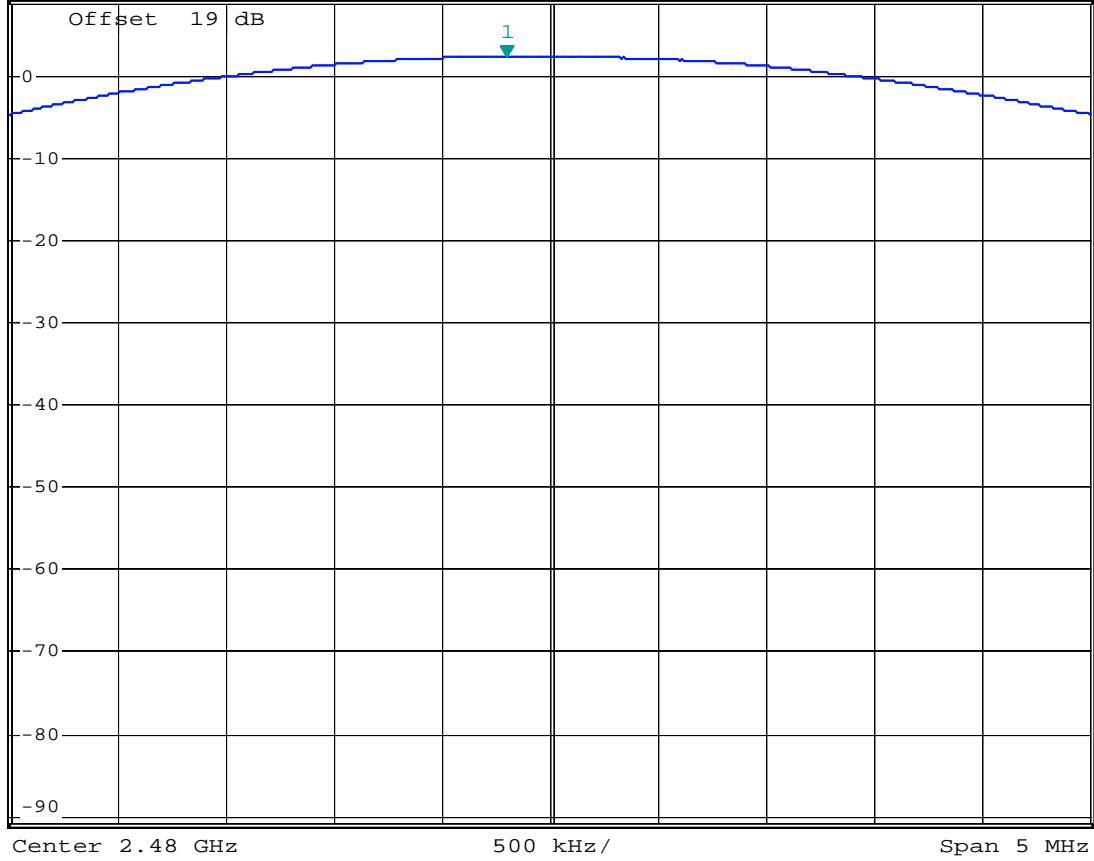

Date: 22.MAR.2006 16:02:59



5.8 Conducted Emission

5.8.1 Measuring Instruments

As described in chapter 6 of this test Report.

5.8.2 Test Procedures :

- a. The EUT was placed 0.4 meter from the conducting wall of the shielding room was kept at least 80 centimeters from any other grounded conducting surface.
- b. Connect EUT to the power port of a line impedance stabilization network (LISN).
- c. All the support units are connected to the other LISN.
- d. The LISN provides 50 ohm coupling impedance for the measuring instrument.
- e. The FCC states that a 50 ohm, 50 microhenry LISN should be used.
- f. Both sides of AC line were checked for maximum conducted interference.
- g. The frequency range from 150 kHz to 30 MHz was searched.
- h. Set the test-receiver system to Peak Detect Function and specified bandwidth with Maximum Hold Mode.



5.8.3 Test Data

- Temperature : 24 °C
- Relating Humidity : 52 %
- Test Engineer : Andy
- Test Mode : Mode 1

The test that passed at minimum margin was marked by the frame in the following table.

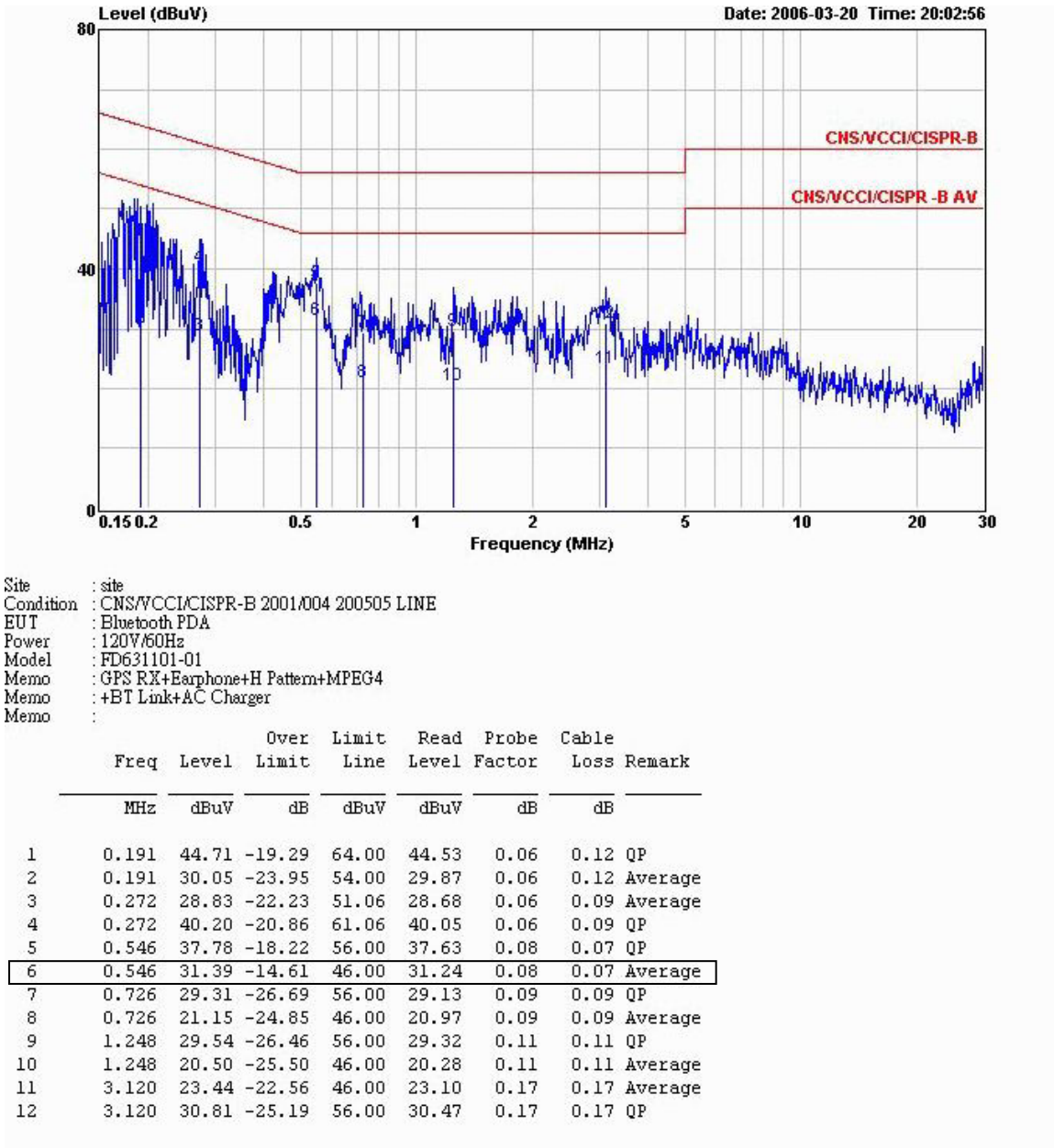

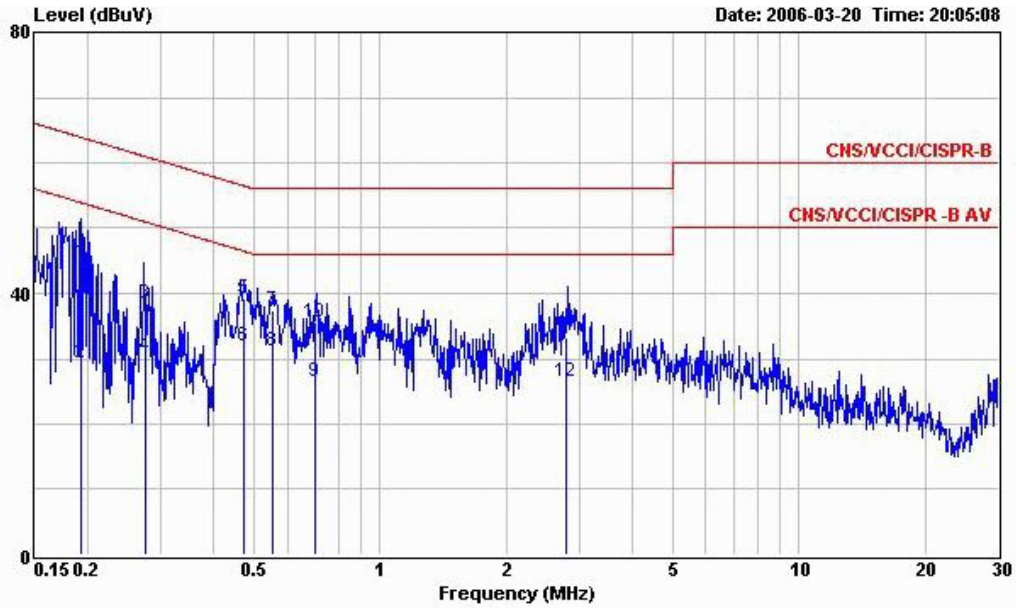

Site : site
 Condition : CNS/VCCI/CISPR-B 2001/004 200505 NEUTRAL
 EUT : Bluetooth PDA
 Power : 120V/60Hz
 Model : FD631101-01
 Memo : GPS RX+Earphone+H Pattern+MPEG4
 Memo : +BT Link+AC Charger
 Memo :

	Freq	Level	Over Limit	Limit Line	Read Level	Probe Factor	Cable Loss	Remark
	MHz	dBuV		dB	dBuV	dB	dB	
1	0.193	44.55	-19.36	63.91	44.32	0.11	0.12	QP
2	0.193	29.41	-24.50	53.91	29.18	0.11	0.12	Average
3	0.274	38.51	-22.48	60.99	38.31	0.11	0.09	QP
4	0.274	30.27	-20.72	50.99	30.07	0.11	0.09	Average
5	0.471	39.25	-17.24	56.49	39.05	0.13	0.07	QP
6	0.471	31.85	-14.64	46.49	31.65	0.13	0.07	Average
7	0.555	37.46	-18.54	56.00	37.24	0.15	0.07	QP
8	0.555	31.29	-14.71	46.00	31.07	0.15	0.07	Average
9	0.702	26.45	-19.55	46.00	26.19	0.18	0.08	Average
10	0.702	35.50	-20.50	56.00	35.24	0.18	0.08	QP
11	2.790	33.43	-22.57	56.00	33.04	0.23	0.16	QP
12	2.790	26.40	-19.60	46.00	26.01	0.23	0.16	Average



- Temperature : 24 °C
- Relating Humidity : 52 %
- Test Enginner : Andy
- Test Mode : Mode 2

The test that passed at minimum margin was marked by the frame in the following table.

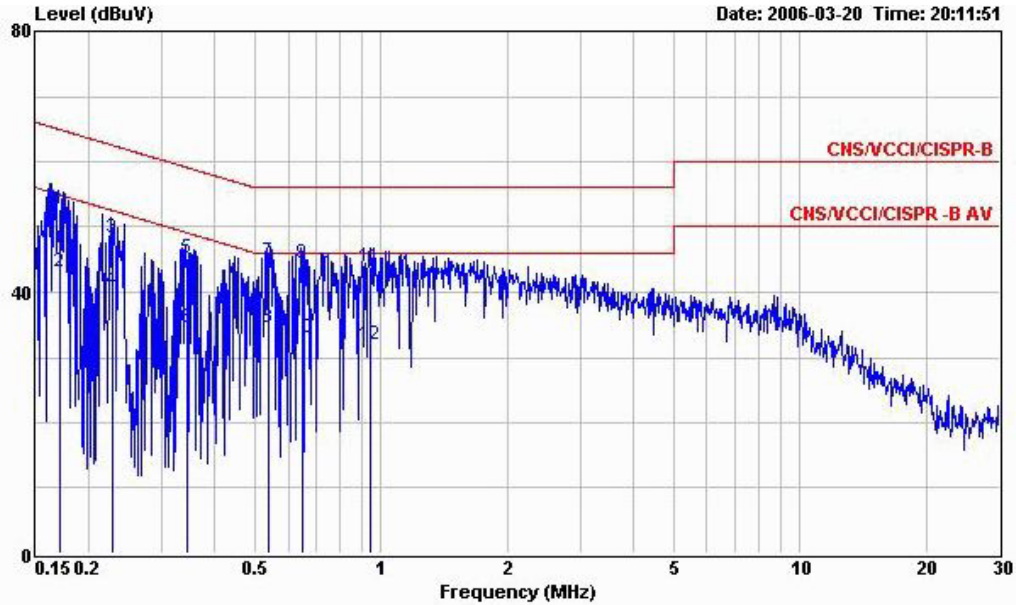

Site : site
 Condition : CNS/VCCI/CISPR-B 2001/004 200505 LINE
 EUT : Bluetooth PDA
 Power : 120V/60Hz(From Notebook)
 Model : FD631101-01
 Memo : GPS RX+Earphone+H Pattern+MPEG4
 Memo : +BT Link+USB Link
 Memo :

	Freq	Level	Over Limit	Limit Line	Read Level	Probe Factor	Cable Loss	Remark
	MHz	dBuV	dB	dBuV	dBuV	dB	dB	
1	0.171	52.74	-12.19	64.93	52.56	0.06	0.12	QP
2	0.171	43.10	-11.83	54.93	42.92	0.06	0.12	Average
3	0.229	48.30	-14.19	62.49	48.13	0.06	0.11	QP
4	0.229	40.31	-12.18	52.49	40.14	0.06	0.11	Average
5	0.344	45.32	-13.79	59.11	45.19	0.06	0.07	QP
6	0.344	34.57	-14.54	49.11	34.44	0.06	0.07	Average
7	0.540	44.79	-11.21	56.00	44.64	0.08	0.07	QP
8	0.540	34.42	-11.58	46.00	34.27	0.08	0.07	Average
9	0.651	44.38	-11.62	56.00	44.21	0.09	0.08	QP
10	0.651	33.07	-12.93	46.00	32.90	0.09	0.08	Average
11	0.943	43.77	-12.23	56.00	43.56	0.11	0.10	QP
12	0.943	31.85	-14.15	46.00	31.64	0.11	0.10	Average

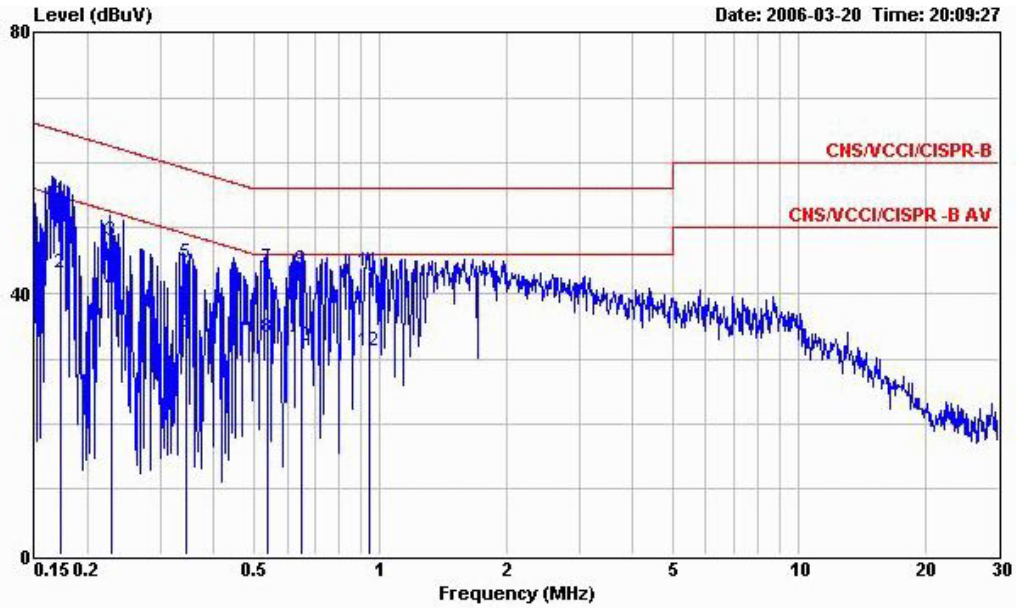

Site : site
 Condition : CNS/VCCI/CISPR-B 2001/004 200505 NEUTRAL
 EUT : Bluetooth PDA
 Power : 120V/60Hz(From Notebook)
 Model : FD631101-01
 Memo : GPS RX+Earphone+H Pattern+MPEG4
 Memo : +BT Link+USB Link
 Memo :

	Freq	Level	Over	Limit	Read	Probe	Cable	
	MHz	dBuV	Limit	Line	Level	Factor	Loss	Remark
			dB	dBuV	dBuV	dB	dB	
1	0.172	53.78	-11.08	64.86	53.55	0.11	0.12	QP
2	0.172	43.21	-11.65	54.86	42.98	0.11	0.12	Average
3	0.228	48.01	-14.50	62.51	47.79	0.11	0.11	QP
4	0.228	40.15	-12.36	52.51	39.93	0.11	0.11	Average
5	0.346	44.59	-14.48	59.07	44.41	0.11	0.07	QP
6	0.346	34.13	-14.94	49.07	33.95	0.11	0.07	Average
7	0.538	44.01	-11.99	56.00	43.79	0.15	0.07	QP
8	0.538	33.29	-12.71	46.00	33.07	0.15	0.07	Average
9	0.650	43.72	-12.28	56.00	43.47	0.17	0.08	QP
10	0.650	31.84	-14.16	46.00	31.59	0.17	0.08	Average
11	0.942	43.28	-12.72	56.00	42.96	0.22	0.10	QP
12	0.942	31.10	-14.90	46.00	30.78	0.22	0.10	Average



5.9 Radiated Emission Measurement

5.9.1 Measuring Instruments

As described in chapter 6 of this Report.

5.9.2 Test Procedures

- a. The EUT was placed on a rotatable table top 0.8 meter above ground.
- b. The EUT was set 3 meters from the interference receiving antenna which was mounted on the top of a variable height antenna tower.
- c. The table was rotated 360 degrees to determine the position of the highest radiation.
- d. The antenna is a broadband antenna and its height is varied between one meter and four meters above ground to find the maximum value of the field strength for both horizontal polarization and vertical polarization of the antenna.
- e. For each suspected emission, the EUT was arranged to its worst case and then tune the antenna tower (from 1 m to 4 m) and turntable (from 0 degree to 360 degrees) to find the maximum reading.
- f. Set the test-receiver system to Peak or CISPR quasi-peak Detect Function and specified bandwidth with Maximum Hold Mode.
- g. For testing below 1GHz, If the emission level of the EUT in peak mode was 3 dB lower than the limit specified, then testing will be stopped and peak values of EUT will be reported, otherwise, the emissions will be repeated one by one using the quasi-peak method and reported.
- h. For testing above 1GHz, the emission level of the EUT in peak mode was 20dB lower than average limit (that means the emission level in average mode also complies with the limit in average mode), then testing will be stopped and peak values of EUT will be reported, otherwise, the emissions will be measured in average mode again and reported.

5.9.3 Typical Test Setup Layout of Radiated Emission

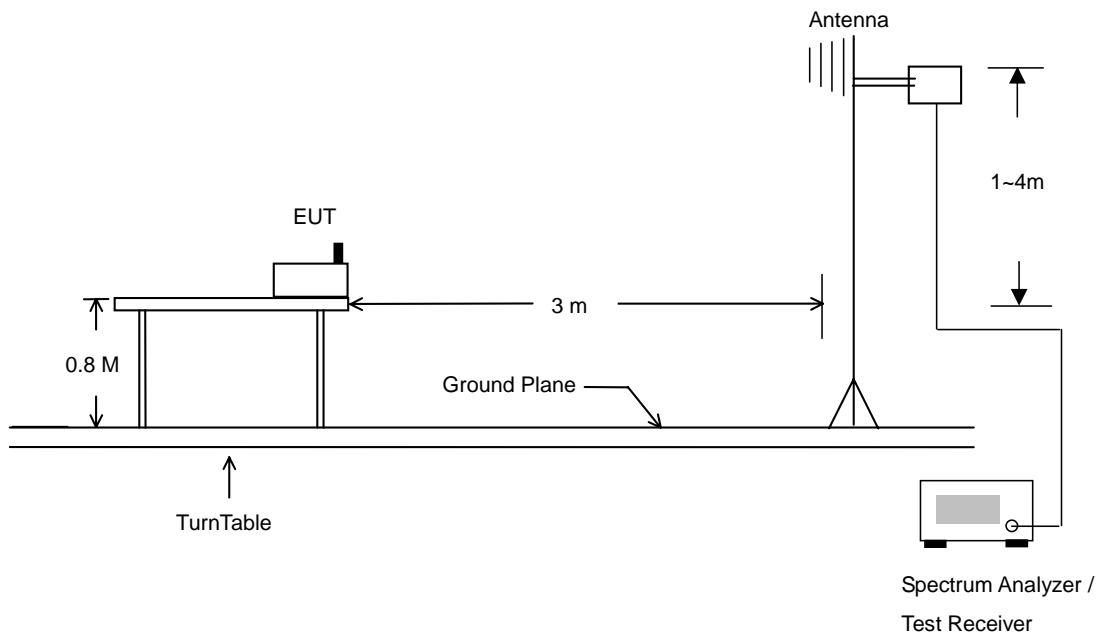



5.9.4 Test Data

- Test Mode : Mode 1
- Polarization : Horizontal

The test that passed at minimum margin was marked by the frame in the following table.

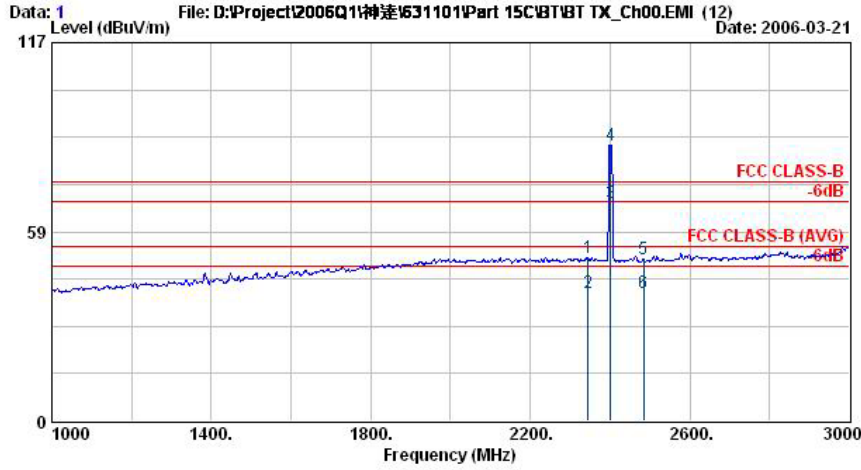

Site : 03CH06-HY
 Condition : HF-ANT-071025-940201 HORIZONTAL
 EUT : GPS Bluetooth PDA
 Power : 120Vac/60Hz
 Model : FR631101
 Memo : Bluetooth TX _CH00;2402MHz
 Plane : E2

	Freq	Level	Over	Limit	Read	Antenna	Preamp	Cable	Ant	Table	Remark
	MHz	dBuV/m	dB	dBuV/m	dBuV	dB/m	dB	dB	cm	deg	
1	2344.00	50.60	-23.40	74.00	51.30	30.52	35.42	4.20	100	0	Peak
2	2344.00	39.40	-14.60	54.00	40.10	30.52	35.42	4.20	100	64	Average
3 X	2402.00	67.32			68.03	30.48	35.46	4.26	100	64	Average
4 X	2402.00	85.22			85.93	30.48	35.46	4.26	100	0	Peak
5	2484.00	50.23	-23.77	74.00	50.97	30.41	35.51	4.36	100	0	Peak
6	2484.00	39.43	-14.57	54.00	40.17	30.41	35.51	4.36	100	64	Average

Remark: #3 and #4 Fundamental Signal.

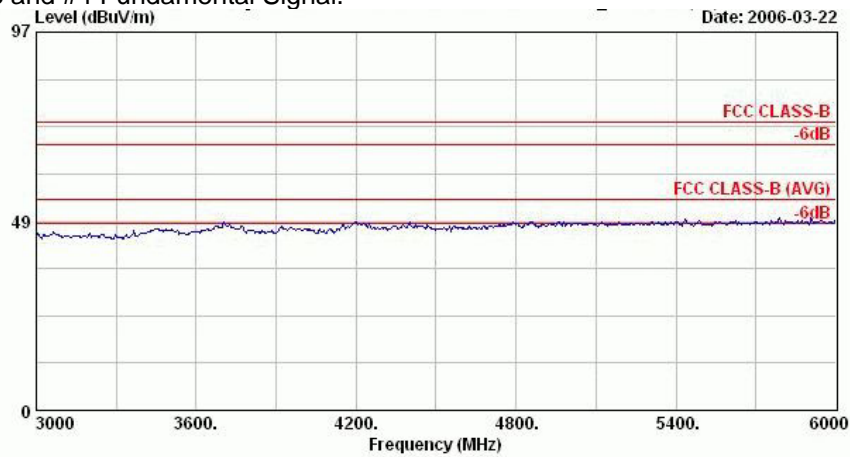

Site : 03CH06-HY
 Condition : HF-ANT-071025-940201 HORIZONTAL
 EUT : GPS Bluetooth PDA
 Power : 120Vac/60Hz
 Model : FR631101
 Memo : Bluetooth TX _CH00;2402MHz
 Plane : E2

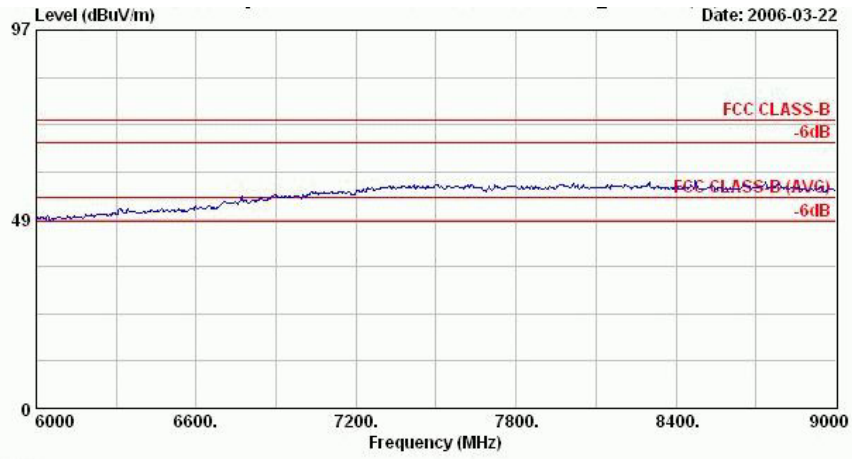

Site : 03CH06-HY
Condition : HF-ANT-071025-940201 HORIZONTAL
EUT : GPS Bluetooth PDA
Power : 120Vac/60Hz
Model : FR631101
Memo : Bluetooth TX _CH00;2402MHz
Plane : E2



- Polarization : Vertical

The test that passed at minimum margin was marked by the frame in the following table.

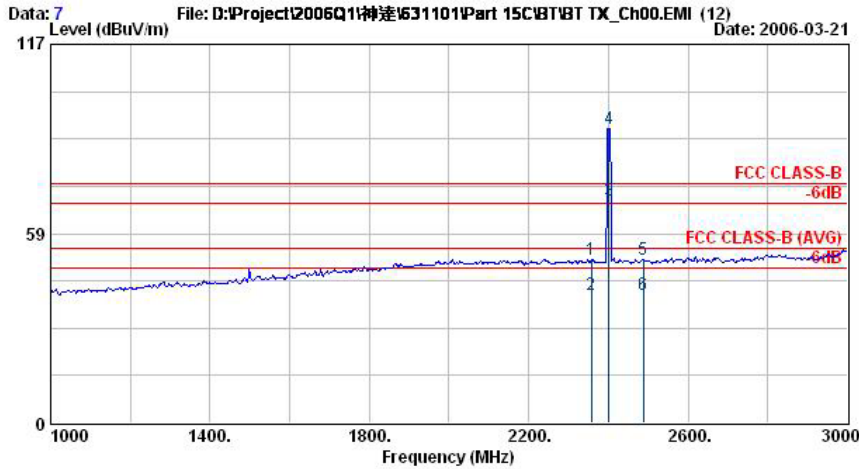

Site : 03CH06-HY
 Condition : HF-ANT-071025-940201 VERTICAL
 EUT : GPS Bluetooth PDA
 Power : 120Vac/60Hz
 Model : FR631101
 Memo : Bluetooth TX_CH00;2402MHz
 Plane : E2

	Freq	Level	Over	Limit	Read	Antenna	Preamp	Cable	Ant	Table	
	MHz	dBuV/m	dB	dBuV/m	dBuV	dB/m	dB	dB	cm	deg	Remark
1	2358.00	50.49	-23.51	74.00	51.20	30.51	35.42	4.20	100	360	Peak
2	2358.00	39.43	-14.57	54.00	40.14	30.51	35.42	4.20	100	280	Average
3 X	2402.00	68.64			69.35	30.48	35.46	4.26	100	280	Average
4 @	2402.00	91.09			91.80	30.48	35.46	4.26	100	360	Peak
5	2488.00	50.39	-23.61	74.00	51.14	30.40	35.51	4.36	100	360	Peak
6	2488.00	39.39	-14.61	54.00	40.14	30.40	35.51	4.36	100	280	Average

Remark: #3 and #4 Fundamental Signal.

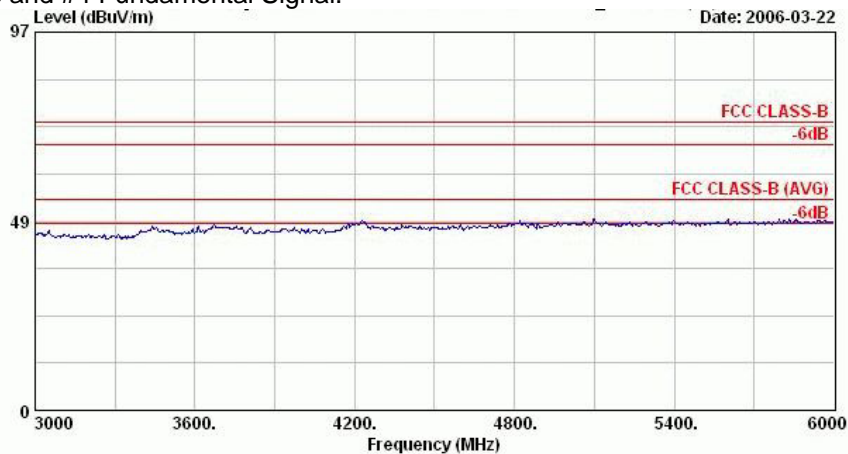

Site : 03CH06-HY
 Condition : HF-ANT-071025-940201 VERTICAL
 EUT : GPS Bluetooth PDA
 Power : 120Vac/60Hz
 Model : FR631101
 Memo : Bluetooth TX_CH00;2402MHz
 Plane : E2

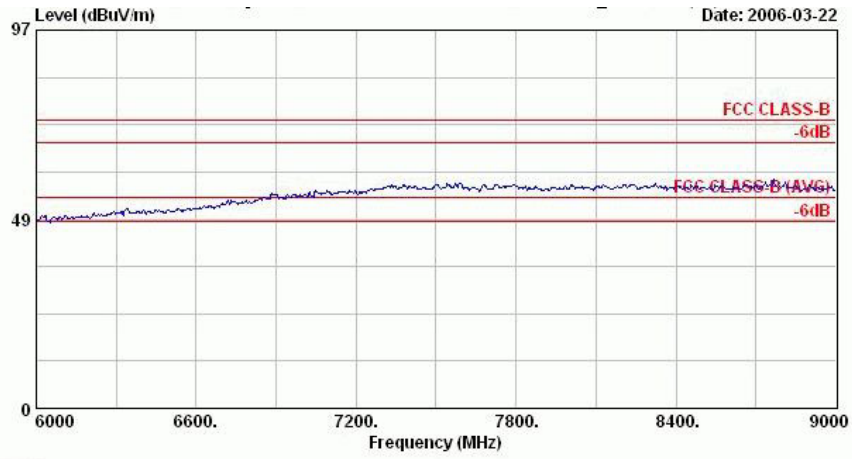

Site : 03CH06-HY
Condition : HF-ANT-071025-940201 VERTICAL
EUT : GPS Bluetooth PDA
Power : 120Vac/60Hz
Model : FR631101
Memo : Bluetooth TX_CH00;2402MHz
Plane : E2



- Test Mode : Mode 2
- Polarization : Horizontal

The test that passed at minimum margin was marked by the frame in the following table.

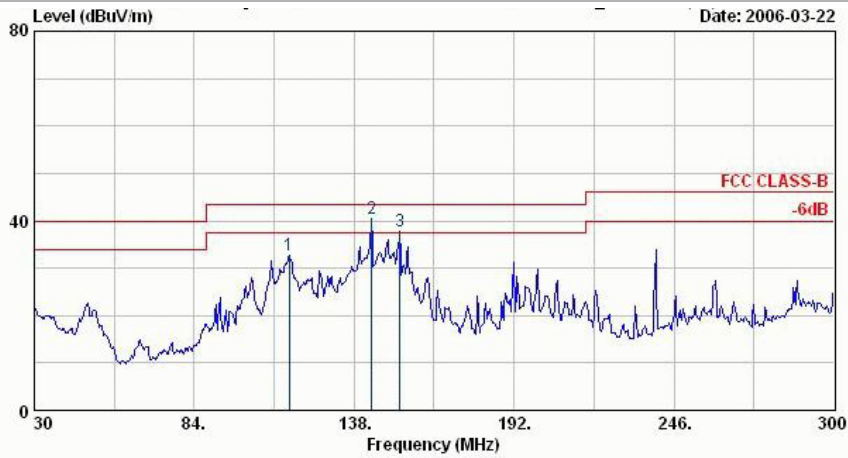

Site : 03CH06-HY
 Condition : BI-LOG-2004-1122 HORIZONTAL
 EUT : GPS Bluetooth PDA
 Power : 120Vac/60Hz
 Model : FR631101
 Memo : Bluetooth TX_CH39,2441MHz
 Plane : E2

	Freq	Level	Over	Limit	ReadAntenna	Preamp	Cable	Ant	Table	Remark
	MHz	dBuV/m	dB	dBuV/m	dBuV	dB/m	dB	dB	cm	deg
1 @	116.13	32.66	-10.84	43.50	49.05	12.38	31.35	2.58	400	0 Peak
2 @	143.94	40.39	-3.11	43.50	58.74	10.24	31.50	2.92	400	0 Peak
3 @	153.39	37.86	-5.64	43.50	57.00	9.34	31.52	3.04	400	0 Peak

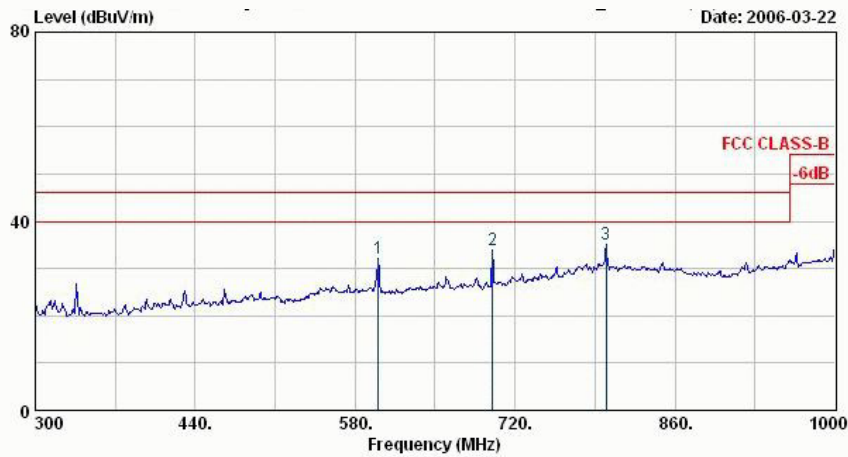

Site : 03CH06-HY
 Condition : BI-LOG-2004-1122 HORIZONTAL
 EUT : GPS Bluetooth PDA
 Power : 120Vac/60Hz
 Model : FR631101
 Memo : Bluetooth TX_CH39,2441MHz
 Plane : E2

	Freq	Level	Over	Limit	ReadAntenna	Preamp	Cable	Ant	Table	Remark
	MHz	dBuV/m	dB	dBuV/m	dBuV	dB/m	dB	dB	cm	deg
1 @	600.30	32.22	-13.78	46.00	38.56	17.94	30.64	6.35	100	0 Peak
2 @	700.40	33.79	-12.21	46.00	38.43	19.04	30.61	6.93	100	0 Peak
3 @	799.80	35.22	-10.78	46.00	35.99	21.90	30.12	7.45	100	0 Peak



Data: 3 File: D:\Project\2006Q1\神達\631101\Part 15C\BTBT TX_Ch39.EMI (20) Date: 2006-03-22

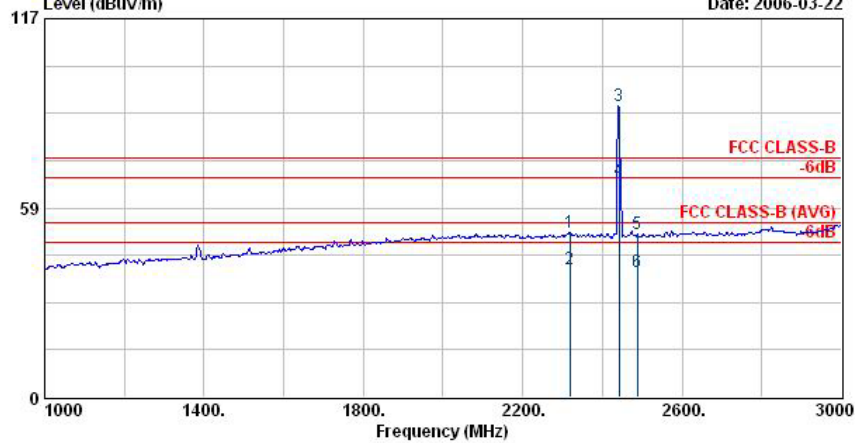

Site : 03CH06-HY
 Condition : HF-ANT-071025-940201 HORIZONTAL
 EUT : GPS Bluetooth PDA
 Power : 120Vac/60Hz
 Model : FR631101
 Memo : Bluetooth TX _CH39;2441MHz
 Plane : E2

	Freq	Level	Over	Limit	ReadAntenna	Preamp	Cable	Ant	Table	Remark
	MHz	dBuV/m	dB	dBuV/m	dBuV	dB/m	dB	cm	deg	
1 @	2318.00	50.85	-23.15	74.00	51.55	30.54	35.40	4.17	107	360 Peak
2 @	2318.00	39.38	-14.62	54.00	40.08	30.54	35.40	4.17	100	60 Average
3 @	2441.00	90.04			90.76	30.44	35.49	4.33	107	360 Peak
4 @	2441.00	66.90			67.63	30.44	35.49	4.33	100	60 Average
5 @	2488.00	50.36	-23.64	74.00	51.12	30.40	35.51	4.36	107	360 Peak
6 @	2488.00	38.90	-15.10	54.00	39.65	30.40	35.51	4.36	100	60 Average

Remark: #3 and #4 Fundamental Signal.

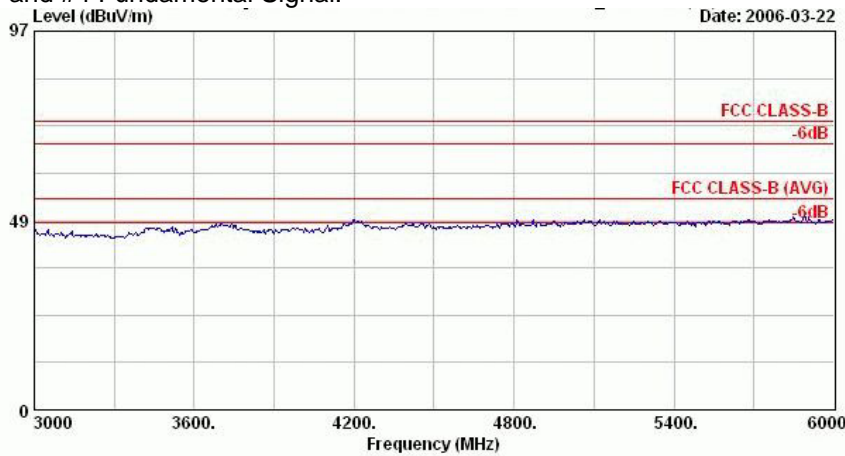

Site : 03CH06-HY
 Condition : HF-ANT-071025-940201 HORIZONTAL
 EUT : GPS Bluetooth PDA
 Power : 120Vac/60Hz
 Model : FR631101
 Memo : Bluetooth TX _CH39;2441MHz
 Plane : E2

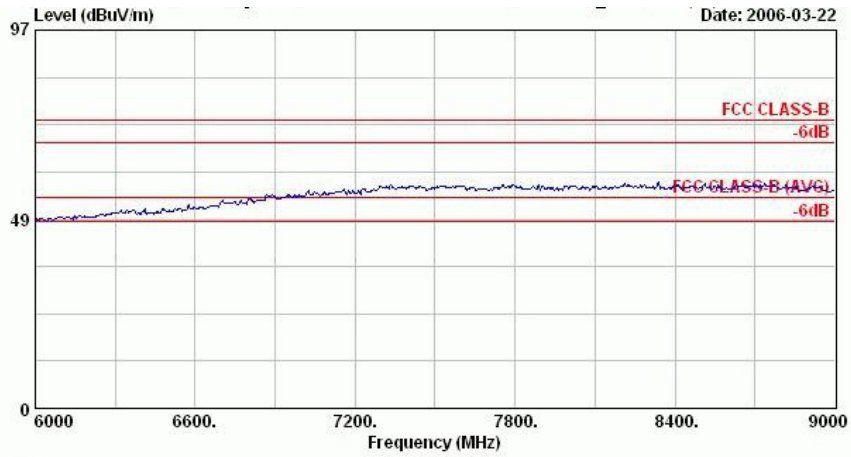

Site : 03CH06-HY
Condition : HF-ANT-071025-940201 HORIZONTAL
EUT : GPS Bluetooth PDA
Power : 120Vac/60Hz
Model : FR631101
Memo : Bluetooth TX_CH39;2441MHz
Plane : E2



- Polarization : Vertical

The test that passed at minimum margin was marked by the frame in the following table.

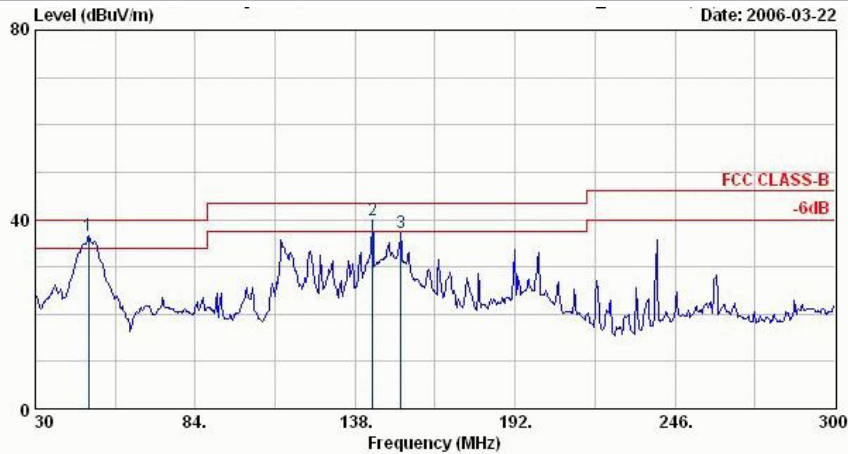

Site : 03CH06-HY
 Condition : BI-LOG-2004-1122 VERTICAL
 EUT : GPS Bluetooth PDA
 Power : 120Vac/60Hz
 Model : FR631101
 Memo : Bluetooth TX _CH39,2441MHz
 Plane : E2

	Freq	Level	Over	Limit	ReadAntenna	Preamp	Cable	Ant	Table	Remark
	MHz	dBUV/m	dB	dBUV/m	dBUV	dB/m	dB	dB	cm	deg
1 @	48.09	36.64	-3.36	40.00	55.82	10.66	31.52	1.69	400	0 Peak
2 @	143.94	39.71	-3.79	43.50	58.05	10.24	31.50	2.92	400	0 Peak
3 @	153.39	37.26	-6.24	43.50	56.40	9.34	31.52	3.04	400	0 Peak

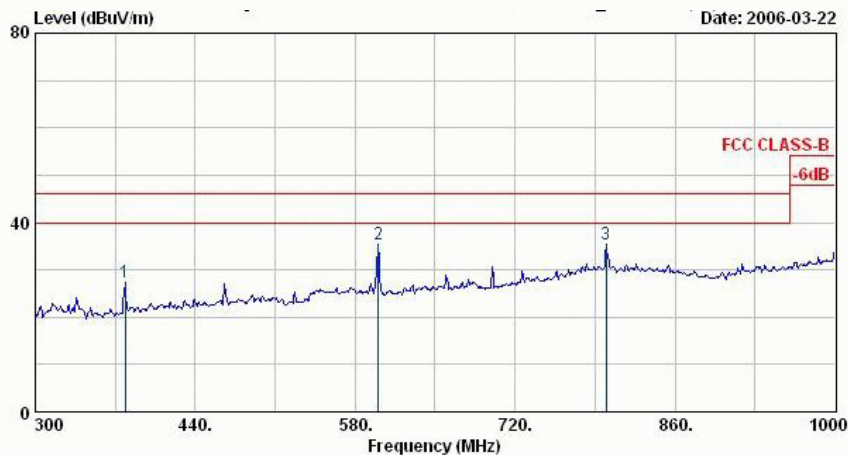

Site : 03CH06-HY
 Condition : BI-LOG-2004-1122 VERTICAL
 EUT : GPS Bluetooth PDA
 Power : 120Vac/60Hz
 Model : FR631101
 Memo : Bluetooth TX _CH39,2441MHz
 Plane : E2

	Freq	Level	Over	Limit	ReadAntenna	Preamp	Cable	Ant	Table	Remark
	MHz	dBUV/m	dB	dBUV/m	dBUV	dB/m	dB	dB	cm	deg
1 @	378.40	27.36	-18.64	46.00	38.14	15.24	30.90	4.88	100	0 Peak
2 @	600.30	35.27	-10.73	46.00	41.62	17.94	30.64	6.35	100	0 Peak
3 @	799.80	35.52	-10.48	46.00	36.29	21.90	30.12	7.45	100	0 Peak



Data: 13 File: D:\Project\2006Q1\神達\631101\Part 15C\BT\BT_TX_Ch39.EMI (20) Date: 2006-03-22

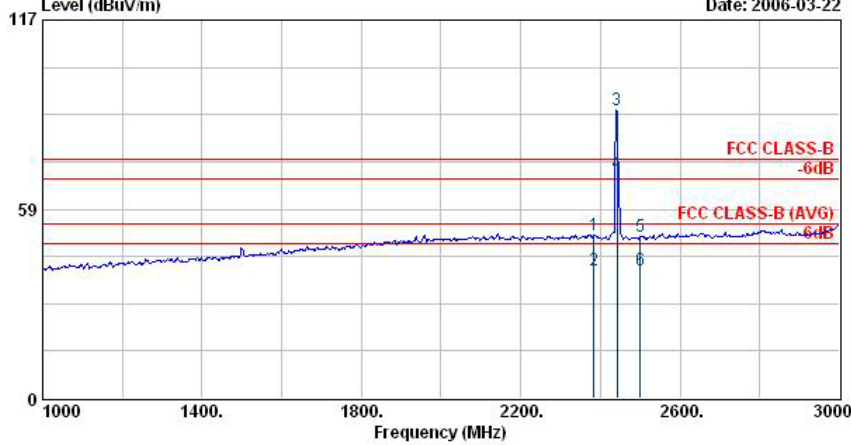

Site : 03CH06-HY
 Condition : HF-ANT-071025-940201 VERTICAL
 EUT : GPS Bluetooth PDA
 Power : 120Vac/60Hz
 Model : FR631101
 Memo : Bluetooth TX _CH39;2441MHz
 Plane : E2

	Freq	Level	Over	Limit	Read	Antenna	Preamp	Cable	Ant	Table	Remark
	MHz	dBUV/m	dB	dBUV/m	dBUV	dB/m	dB	dB	cm	deg	
1 @	2384.00	50.63	-23.37	74.00	51.34	30.50	35.44	4.23	100	357	Peak
2 @	2384.00	39.45	-14.55	54.00	40.16	30.50	35.44	4.23	107	32	Average
3 @	2441.00	89.10			89.83	30.44	35.49	4.33	100	357	Peak
4 @	2441.00	69.55			70.28	30.44	35.49	4.33	107	32	Average
5 @	2500.00	49.84	-24.16	74.00	50.58	30.40	35.53	4.39	100	357	Peak
6 @	2500.00	39.44	-14.56	54.00	40.18	30.40	35.53	4.39	107	32	Average

Remark: #3 and #4 Fundamental Signal.

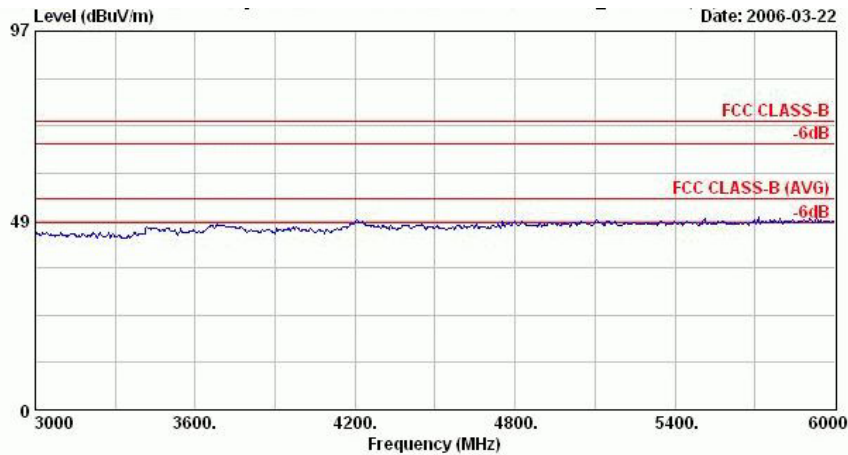

Site : 03CH06-HY
 Condition : HF-ANT-071025-940201 VERTICAL
 EUT : GPS Bluetooth PDA
 Power : 120Vac/60Hz
 Model : FR631101
 Memo : Bluetooth TX _CH39;2441MHz
 Plane : E2

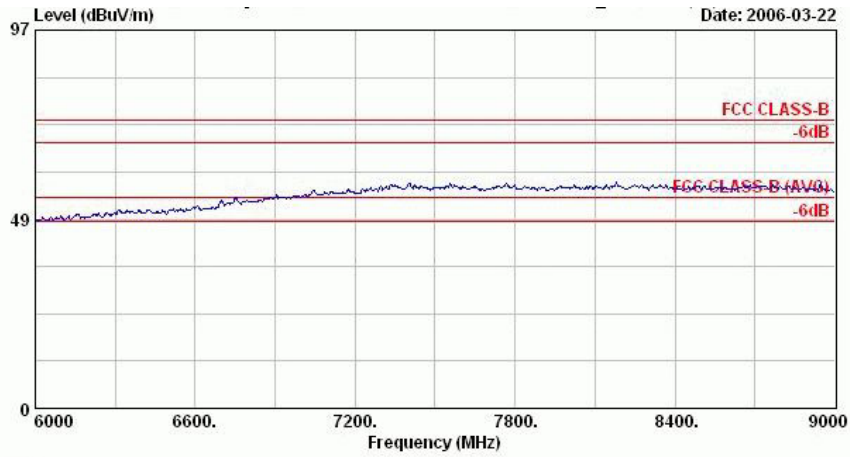

Site : 03CH06-HY
Condition : HF-ANT-071025-940201 VERTICAL
EUT : GPS Bluetooth PDA
Power : 120Vac/60Hz
Model : FR631101
Memo : Bluetooth TX_CH39,2441MHz
Plane : E2



- Test Mode : Mode 3
- Polarization : Horizontal

The test that passed at minimum margin was marked by the frame in the following table.

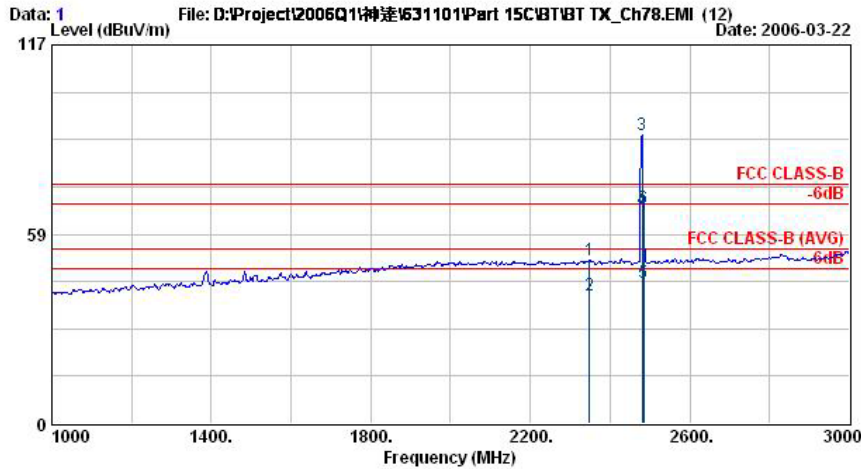

Site : 03CH06-HY
 Condition : HF-ANT-071025-940201 HORIZONTAL
 EUT : GPS Bluetooth PDA
 Power : 120Vac/60Hz
 Model : FR631101
 Memo : Bluetooth TX _CH78;2480MHz
 Plane : E2

	Freq	Level	Over	Limit	Read	Antenna	Preamp	Cable	Ant	Table	Remark
	MHz	dBuV/m	dB	dBuV/m	dBuV	dB/m	dB	dB	cm	deg	
1 @	2348.00	50.42	-23.58	74.00	51.12	30.52	35.42	4.20	100	4	Peak
2 @	2348.00	39.49	-14.51	54.00	40.19	30.52	35.42	4.20	100	25	Average
3 @	2480.00	89.16			89.90	30.41	35.51	4.36	100	4	Peak
4 @	2480.00	66.11			66.85	30.41	35.51	4.36	100	25	Average
5 @	2483.50	43.45	-10.55	54.00	44.19	30.41	35.51	4.36	100	25	Average
6 @	2483.50	66.45	-7.55	74.00	67.19	30.41	35.51	4.36	100	4	Peak

Remark: #3 and #4 Fundamental Signal.

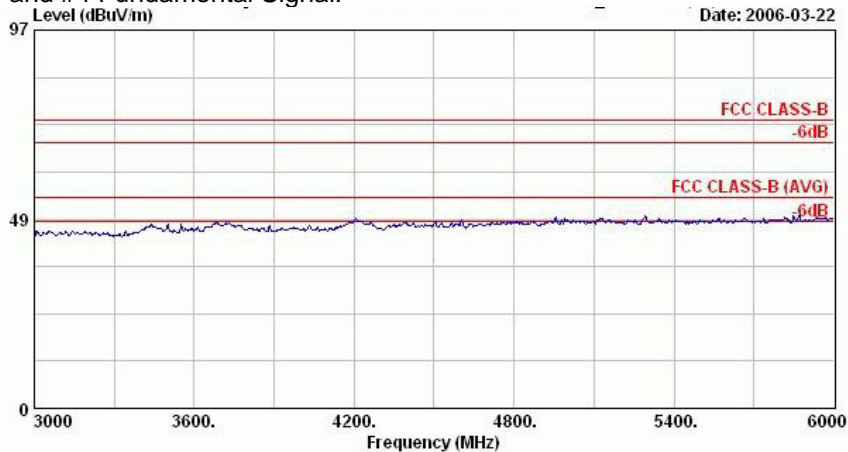

Site : 03CH06-HY
 Condition : HF-ANT-071025-940201 HORIZONTAL
 EUT : GPS Bluetooth PDA
 Power : 120Vac/60Hz
 Model : FR631101
 Memo : Bluetooth TX _CH78;2480MHz
 Plane : E2

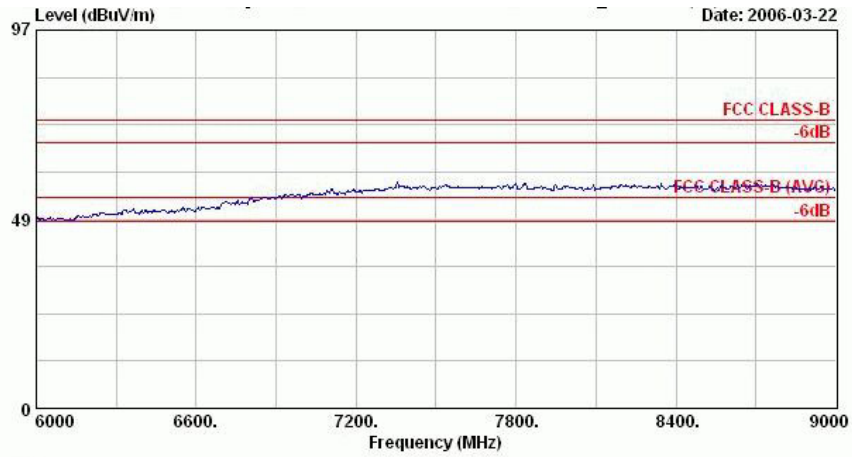

Site : 03CH06-HY
Condition : HF-ANT-071025-940201 HORIZONTAL
EUT : GPS Bluetooth PDA
Power : 120Vac/60Hz
Model : FR631101
Memo : Bluetooth TX_CH78,2480MHz
Plane : E2



- Polarization : Vertical

The test that passed at minimum margin was marked by the frame in the following table.

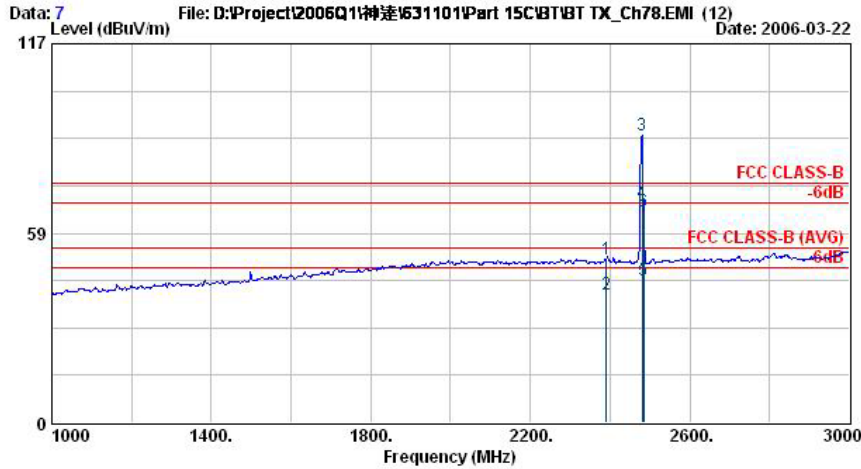

Site : 03CH06-HY
 Condition : HF-ANT-071025-940201 VERTICAL
 EUT : GPS Bluetooth PDA
 Power : 120Vac/60Hz
 Model : FR631101
 Memo : Bluetooth TX _CH78;2480MHz
 Plane : E2

	Freq	Level	Over Limit	Limit Line	Read Level	Antenna Factor	Preamp Factor	Cable Loss	Ant Pos	Table Pos	Remark
	MHz	dBuV/m	dB	dBuV/m	dBuV	dB/m	dB	dB	cm	deg	
1 @	2390.00	50.54	-23.46	74.00	51.26	30.48	35.46	4.26	100	333	Peak
2 @	2390.00	39.39	-14.61	54.00	40.10	30.48	35.46	4.26	100	260	Average
3 @	2480.00	88.63			89.37	30.41	35.51	4.36	100	333	Peak
4 @	2480.00	68.00			68.74	30.41	35.51	4.36	100	260	Average
5 @	2483.50	43.92	-10.08	54.00	44.66	30.41	35.51	4.36	100	260	Average
6 @	2483.50	65.43	-8.57	74.00	66.17	30.41	35.51	4.36	100	333	Peak

Remark: #3 and #4 Fundamental Signal.

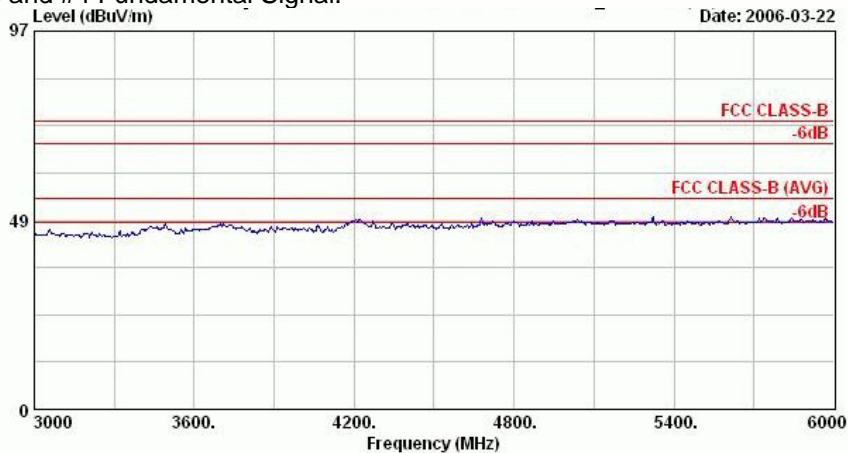

Site : 03CH06-HY
 Condition : HF-ANT-071025-940201 VERTICAL
 EUT : GPS Bluetooth PDA
 Power : 120Vac/60Hz
 Model : FR631101
 Memo : Bluetooth TX _CH78;2480MHz
 Plane : E2

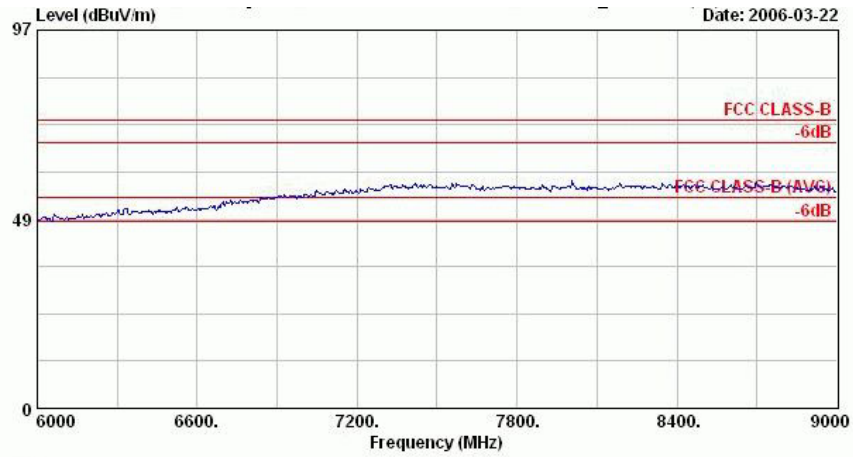

Site : 03CH06-HY
Condition : HF-ANT-071025-940201 VERTICAL
EUT : GPS Bluetooth PDA
Power : 120Vac/60Hz
Model : FR631101
Memo : Bluetooth TX_CH78,2480MHz
Plane : E2

Remark: There is no more obvious spurious emission except the listings above.



5.10 Antenna Requirements

5.10.1 Standard Applicable

For intentional device, according to FCC 47 CFR Section 15.203, an intentional radiator shall be designed to ensure that no other antenna except assembled by the responsible party shall be used with the device.

And according to FCC 47 CFR Section 15.247 (b), if directional gain of transmitting antennas is greater than 6dBi, the power shall be reduced by the same level in dB comparing to gain minus 6dBi.

5.10.2 Antenna Connected Construction

The antenna used in this product is patch antenna. There is no connector on antenna port and it is considered to meet antenna requirement of FCC.

5.10.3 Antenna Gain

The antenna gain of EUT is less than 6 dBi. Therefore, it is not necessary to reduce maximum peak output power limit.



6. List of Measuring Equipments Used

Instrument	Manufacturer	Model No.	Serial No.	Characteristics	Calibration Date	Due Date	Remark
EMC Receiver	R&S	ESCS 30	100174	9kHz – 2.75GHz	Oct. 19, 2005	Oct. 19, 2006	Conduction (CO01-HY)
LISN	MessTec	NNB-2/16Z	2001/009	9kHz – 30MHz	Apr. 26, 2005	Apr. 26, 2006	Conduction (CO01-HY)
LISN (Support Unit)	MessTec	NNB-2/16Z	2001/004	9kHz – 30MHz	Apr. 20, 2005	Apr. 20, 2006	Conduction (CO01-HY)
EMI Filter	LINDGREN	LRE-2060	1004	< 450Hz	N/A	N/A	Conduction (CO01-HY)
EMI Filter	LINDGREN	N6006	201052	0 – 60Hz	N/A	N/A	Conduction (CO01-HY)
RF Cable-CON	Suhner Switzerland	RG223/U	CB029	9kHz – 30MHz	Dec. 22, 2005	Dec. 22, 2006	Conduction (CO01-HY)
Spectrum analyzer	Agilent	E4408B	MY44211030	9KHz-26.5GHz	Jul. 25, 2005	Jul. 24, 2006	Radiation (03CH06-HY)
Receiver	R&S	ESCS30	100356	9KHz-2.75GHz	Jun. 28, 2005	Jun. 27, 2006	Radiation (03CH06-HY)
Controller	CT	SC100	N/A	N/A	N/A	N/A	Radiation (03CH06-HY)
Bilog Antenna	SCHAFFNER	CBL6112B	2885	30MHz -2GHz	Nov. 22, 2004	Nov. 22, 2006	Radiation (03CH06-HY)
Horn Antenna	Com-Power	AH118	071025	1G-18G	Feb. 1, 2005	Feb. 1, 2007	Radiation (03CH06-HY)
SHF-EHF Horn	SCHWARZBECK	BBHA 9170	9170-249	14G - 40G	Jul. 21, 2005	Jul. 20, 2006	Radiation (03CH06-HY)
Amplifier	MITEQ	AMF-6F	997165	26G - 40G	Jul. 21, 2005	Jul. 20, 2006	Radiation (03CH06-HY)
Turn Table	HD	DS 420	420/650/00	0 ~ 360 degree	N/A	N/A	Radiation (03CH06-HY)
Antenna Mast	HD	MA 240	240/560/00	1 m - 4 m	N/A	N/A	Radiation (03CH06-HY)



7. Uncertainty Evaluation

Uncertainty of Conducted Emission Measurement (150kHz ~ 30MHz)

Contribution	Uncertainty of x_i		$u(x_i)$
	dB	Probability Distribution	
Receiver reading	0.10	Normal(k=2)	0.05
Cable loss	0.10	Normal(k=2)	0.05
AMN insertion loss	2.50	Rectangular	0.63
Receiver Spec	1.50	Rectangular	0.43
Site imperfection	1.39	Rectangular	0.80
Mismatch	+0.34/-0.35	U-shape	0.24
combined standard uncertainty Uc(y)	1.13		
Measuring uncertainty for a level of confidence of 95% U=2Uc(y)	2.26		

Uncertainty of Radiated Emission Measurement (30MHz ~ 1000MHz)

Contribution	Uncertainty of x_i		$u(x_i)$
	dB	Probability Distribution	
Receiver reading	0.41	Normal(k=2)	0.21
Antenna factor calibration	0.83	Normal(k=2)	0.42
Cable loss calibration	0.25	Normal(k=2)	0.13
Pre Amplifier Gain calibration	0.27	Normal(k=2)	0.14
RCV/SPA specification	2.50	Rectangular	0.72
Antenna Factor Interpolation for Frequency	1.00	Rectangular	0.29
Site imperfection	1.43	Rectangular	0.83
Mismatch	+0.39/-0.41	U-shaped	0.28
combined standard uncertainty Uc(y)	1.27		
Measuring uncertainty for a level of confidence of 95% U=2Uc(y)	2.54		



Uncertainty of Radiated Emission Measurement (1GHz ~ 40GHz)

Contribution	Uncertainty of x_i		$u(x_i)$	C_i	$C_i * u(x_i)$
	dB	Probability Distribution			
Receiver reading	±0.10	Normal(k=1)	0.10	1	0.10
Antenna factor calibration	±1.70	Normal(k=2)	0.85	1	0.85
Cable loss calibration	±0.50	Normal(k=2)	0.25	1	0.25
Receiver Correction	±2.00	Rectangular	1.15	1	1.15
Antenna Factor Directional	±1.50	Rectangular	0.87	1	0.87
Site imperfection	±2.80	Triangular	1.14	1	1.14
Mismatch Receiver VSWR $\Gamma_1 = 0.197$ Antenna VSWR $\Gamma_2 = 0.194$ Uncertainty = $20 \log(1 - \Gamma_1 * \Gamma_2 * \Gamma_3)$	+0.34/-0.35	U-shaped	0.244	1	0.244
Combined standard uncertainty $U_c(y)$	2.36				
Measuring uncertainty for a level of confidence of 95% $U = 2U_c(y)$	4.72				