

# Circuit Description

## 1. Overview

RFT6100(U103) receives modulated digital signals from the MSM6050(U7) of the digital circuit and then, changes them into analog signals by the digital/analog converter (DAC, D/A Converter) in order to create baseband signals. Created baseband signals are changed into RF signals by RFT6100(U103). They are amplified at the Power AMP(U204, U6). Finally, they are sent out to the cell site via the antenna after going through the isolator and duplexer.

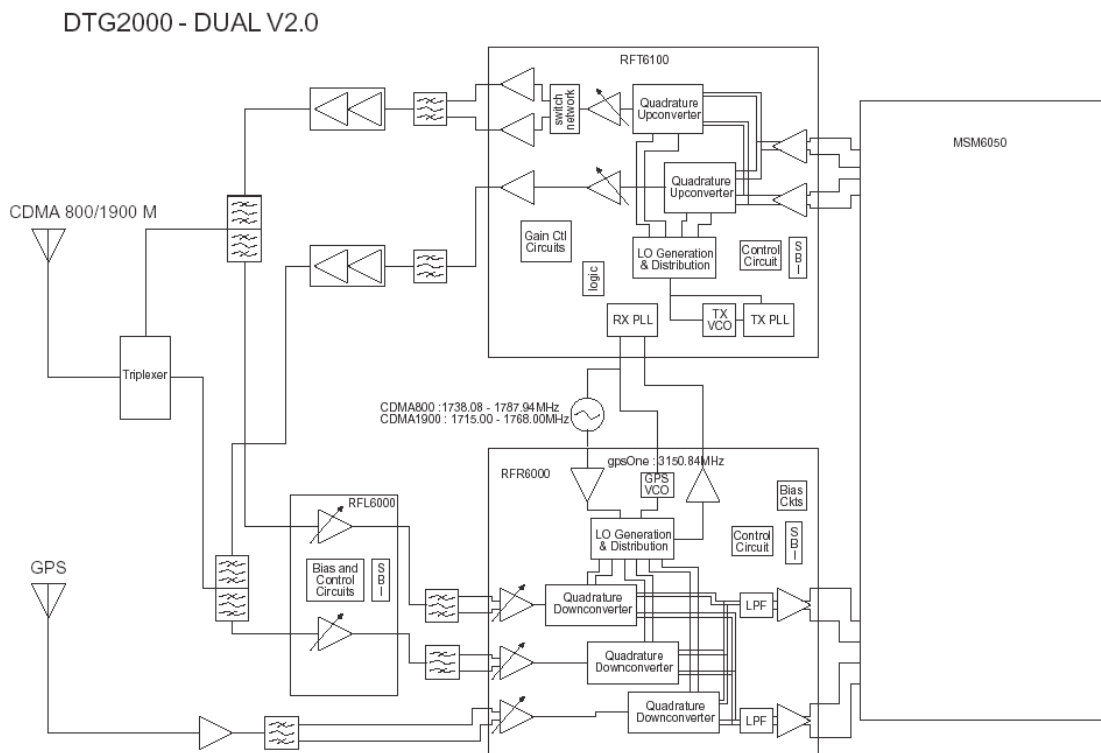

Figure 1. DTG2000-DUAL V2.0 Block Diagram

## 2. RF Transmit / Receive Part

### 2.1. Tx Baseband Processors, RFT6100 (U103)

The RFT6100(U103) includes digital-to-analog converters(DAC) for converting digital baseband to analog baseband, low-pass filters, a mixer for up-converting to RF and an 85 dB dynamic range Tx AGC amplifier. The RFT6100(U103) includes a fully programmable phase-locked loop(PLL) for generating Rx LO.

### 2.2. Transmit Bandpass Filter (FL3, FL4)

Transmit signals that have been converted RF signals are inputted into the Power Amp(U6, U204)

after passing through RF BPF(FL3, FL4) in order to filter out noise signals amplified during the amplification of RF signals. This is carried out in order to create power level inputted to the Power AMP(U204, U6) via RF BPF (FL3, FL4). IL of two RF BPFs is 4dB as a maximum, whereas the ripple in the passing band is 2dB(maximum). The degree of the suppression of transmit signals on receive band is at least 20dB or greater. The maximum power that can be inputted is about 25dBm.

### **2.3. Power Amplifier (U6, U204)**

The power amplifier(U204, U6) that can be used in the CDMA mode has linear amplification capability. For higher efficiency, it is made up of one MMIC (Monolithic Microwave Integrated Circuit) for which RF input terminal and internal interface circuit are integrated onto one IC after going through the AlGaAs/GaAs HBT (heterojunction bipolar transistor) process. The module of power amplifier is made up of an output end interface circuit including this MMIC. The maximum power that can be inputted through the input terminal is +17dBm and conversion gain is about 28dB. RF transmit signals that have been amplified through the power amplifier are sent to the duplexer and then, sent out to the cell site through the antenna in order to prevent any damages on circuits, that may be generated by output signals reflected from the duplexer and re-inputted to the power amplifier output end.

### **2.4. Description of Frequency Synthesizer Circuit**

#### **2.4.1 Voltage Control Temperature Compensation Crystal Oscillator(TCX1)**

The temperature range that can be compensated by TCX1 which is the reference frequency generator of mobile terminal is -30 ~ +80 degrees. TCX1 receives frequency tuning signals called TRK\_LO\_ADJ from MSM as 0.5V~2.5V DC via R and C filters in order to generate the reference frequency of 19.2MHz and input it into the frequency synthesizer of UHF band. Frequency stability depending on temperature is  $\pm 2.0$  ppm.

#### **2.4.2 Voltage Control Crystal Oscillator (VCO1)**

VCO that generates the LO frequency of mobile terminal receives the output voltage of PLL. The sensitivity on control voltage is 23MHz/v and the output level is 0dBm.