

Fujian Flaircomm Microelectronics, Inc.

WiFi and BT combo module

Main Model: FLC-CBM202

Serial Model: See P5

January 24, 2013

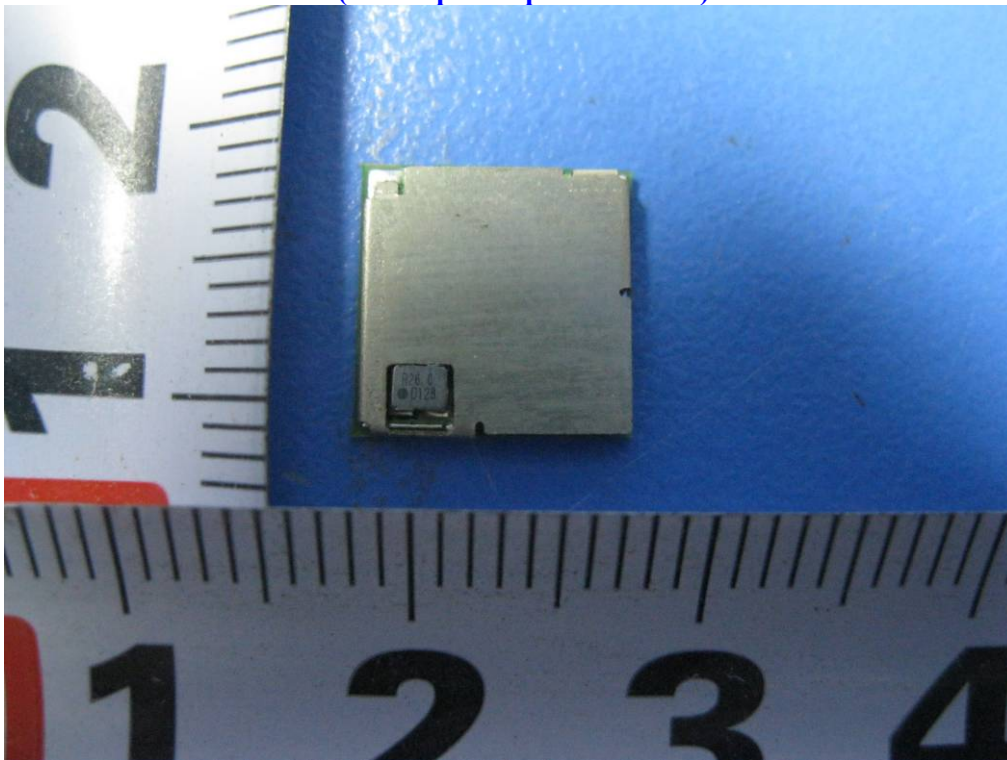

Report No.: 12021036-FCC-R3

(This report supersedes none)



Modifications made to the product : None

This Test Report is Issued Under the Authority of:

		
Alan Lv Compliance Engineer	Alex Liu Technical Manager	

This test report may be reproduced in full only.
Test result presented in this test report is applicable to the representative sample only.

RF Test Report

To: FCC Part 15.247: 2012, ANSI C63.4: 2009

SIEMIC, INC.
Accessing global markets



Laboratory Introduction

SIEMIC, headquartered in the heart of Silicon Valley, with superior facilities in US and Asia, is one of the leading independent testing and certification facilities providing customers with one-stop shop services for Compliance Testing and Global Certifications.



In addition to [testing](#) and [certification](#), SIEMIC provides initial design reviews and [compliance management](#) through out a project. Our extensive experience with [China](#), [Asia Pacific](#), [North America](#), [European](#), and [international](#) compliance requirements, assures the fastest, most cost effective way to attain regulatory compliance for the [global markets](#).

Accreditations for Conformity Assessment

Country/Region	Accreditation Body	Scope
USA	FCC, A2LA	EMC , RF/Wireless , Telecom
Canada	IC, A2LA, NIST	EMC, RF/Wireless , Telecom
Taiwan	BSMI , NCC , NIST	EMC, RF, Telecom , Safety
Hong Kong	OFTA , NIST	RF/Wireless ,Telecom
Australia	NATA, NIST	EMC, RF, Telecom , Safety
Korea	KCC/RRA, NIST	EMI, EMS, RF , Telecom, Safety
Japan	VCCI, JATE, TELEC, RFT	EMI, RF/Wireless, Telecom
Mexico	NOM, COFETEL, Caniety	Safety, EMC , RF/Wireless, Telecom
Europe	A2LA, NIST	EMC, RF, Telecom , Safety

Accreditations for Product Certifications

Country/Region	Accreditation Body	Scope
USA	FCC TCB, NIST	EMC , RF , Telecom
Canada	IC FCB , NIST	EMC , RF , Telecom
Singapore	iDA, NIST	EMC , RF , Telecom
EU	NB	EMC & R&TTE Directive
Japan	MIC, (RCB 208)	RF , Telecom
Hong Kong	OFTA (US002)	RF , Telecom



SIEMIC, INC.

Accessing global markets

Title: RF Test Report for WiFi and BT combo module
Main Model: FLC-CBM202
Serial Model: See P5
To: FCC Part 15.247: 2012, ANSI C63.4: 2009

Report No.: 12021036-FCC-R3
Issue Date: January 24, 2013
Page: 3 of 46
www.siemic.com.cn

This page has been left blank intentionally.

CONTENTS

1	EXECUTIVE SUMMARY & EUT INFORMATION	5
2	TECHNICAL DETAILS	6
3	MODIFICATION.....	7
4	TEST SUMMARY.....	8
5	MEASUREMENTS, EXAMINATION AND DERIVED RESULTS	9
	ANNEX A. TEST INSTRUMENT & METHOD	29
	ANNEX B. EUT AND TEST SETUP PHOTOGRAPHS	34
	ANNEX C. TEST SETUP AND SUPPORTING EQUIPMENT.....	39
	ANNEX D. USER MANUAL / BLOCK DIAGRAM / SCHEMATICS / PART LIST	43
	ANNEX E. DECLARATION OF SIMILARITY	44

1 EXECUTIVE SUMMARY & EUT INFORMATION

The purpose of this test programme was to demonstrate compliance of the Fujian Flaircomm Microelectronics, Inc., WiFi and BT combo module and model: FLC-CBM202 against the current Stipulated Standards. The WiFi and BT combo module has demonstrated compliance with the FCC Part 15.247: 2012, ANSI C63.4: 2009

EUT Information

- EUT Description** : WiFi and BT combo module
- Main Model** : FLC-CBM202
- Serial Model** : FLC- CBM202CL2A; FLC- CBM202IL2A; FLC- CBM202VL2A
- Antenna Gain** : 2.8 dBi
- Input Power** : Input: 1.8 ~ 3.3V DC
- Temperature** : -40° C to +85° C for A and I grade
-20° C to +70° C for V and C grade
- Classification**
- Per Stipulated** : FCC Part 15.247: 2012, ANSI C63.4: 2009
- Test Standard**

NOTE: in this report, we choice the model FLC-CBM202 to test, and the differences of them please refer to the Annex E. DECLARATION OF SIMILARITY.

2 TECHNICAL DETAILS

Purpose	Compliance testing of WiFi and BT combo module with stipulated standard
Applicant / Client	Fujian Flaircomm Microelectronics,Inc. 7F,Guomai Building,116 East JiangBin Ave,Fuzhou,Fujian,China.
Manufacturer	Fujian Flaircomm Microelectronics,Inc. 7F,Guomai Building,116 East JiangBin Ave,Fuzhou,Fujian,China.
Laboratory performing the tests	SIEMIC Nanjing (China) Laboratories NO.2-1,Longcang Dadao, Yuhua Economic Development Zone, Nanjing, China Tel:+86(25)86730128/86730129 Fax:+86(25)86730127 Email:info@siemic.com
Test report reference number	12021036-FCC-R3
Date EUT received	December 12, 2012
Standard applied	FCC Part 15.247: 2012, ANSI C63.4: 2009
Dates of test (from – to)	January 22 to January 23, 2013
No of Units :	#1
Equipment Category :	DTS
Trade Name :	N/A
RF Operating Frequency (ies)	Bluetooth & BLE: 2402 - 2480 MHz WIFI: 802.11b/g/n: 2412-2462 MHz
Number of Channels	Bluetooth: 79 CH WIFI: 11CH BLE: 40CH
Modulation	Bluetooth: GFSK, $\pi/4$-DQPSK, 8DPSK WIFI: DSSS/OFDM BLE: GFSK
FCC ID	P4ICBM202



SIEMIC, Inc.

Accessing global markets

Title: RF Test Report for WiFi and BT combo module
Main Model: FLC-CBM202
Serial Model: See P5
To: FCC Part 15.247: 2012, ANSI C63.4: 2009

Report No.: 12021036-FCC-R3
Issue Date: January 24, 2013
Page: 7 of 46
www.siemc.com.cn

3 MODIFICATION

NONE

4 TEST SUMMARY

The product was tested in accordance with the following specifications.
 All testing has been performed according to below product classification:

Test Results Summary

FCC Rules	Description of Test	Result
§15.203	Antenna Requirement	Pass
§15.247 (a)(2)	6 dB Bandwidth	Pass
§15.247(b)(3)	Conducted Maximum Output Power	Pass
§15.247(e)	Power Spectral Density	Pass
§15.247(d)	Band Edge & Conducted Spurious Emissions	Pass
§15.207 (a),	AC Power Line Conducted Emissions	Pass
§15.205, §15.209, §15.247(d)	Radiated Spurious Emissions & Restricted Bands	Pass

5 MEASUREMENTS, EXAMINATION AND DERIVED RESULTS

5.1 §15.203 - ANTENNA REQUIREMENT

Applicable Standard

According to § 15.203, an intentional radiator shall be designed to ensure that no antenna other than that furnished by the responsible party shall be used with the device. The use of a permanently attached antenna or of an antenna that uses a unique coupling to the intentional radiator shall be considered sufficient to comply with the provisions of this section. The manufacturer may design the unit so that a broken antenna can be replaced by the user, but the user of a standard antenna jack or electrical connector is prohibited. The structure and application of the EUT were analyzed to determine compliance with section §15.203 of the rules. §15.203 state that the subject device must meet the following criteria:

- a. Antenna must be permanently attached to the unit.
- b. Antenna must use a unique type of connector to attach to the EUT.

Unit must be professionally installed, and installer shall be responsible for verifying that the correct antenna is employed with the unit.

And according to FCC 47 CFR section 15.247 (b), if the transmitting antennas of directional gain greater than 6dBi are used, the power shall be reduced by the amount in dB that the directional gain of the antenna exceeds 6 dBi.

Antenna Connector Construction

EUT antenna is integrated on PCB; It is in accordance to section 15.203(a); please refer to the internal photos.

Result: Pass.

5.2 §15.247(a) (2) – 6 dB BANDWIDTH TESTING

1. Conducted Measurement
EUT was set for low, mid, high channel with modulated mode and highest RF output power.
The spectrum analyzer was connected to the antenna terminal.
2. Environmental Conditions

Temperature	15°C
Relative Humidity	50%
Atmospheric Pressure	1019mbar
3. Conducted Emissions Measurement Uncertainty
All test measurements carried out are traceable to national standards. The uncertainty of the measurement at a confidence level of approximately 95% (in the case where distributions are normal), with a coverage factor of 2, in the range 30MHz – 40GHz is ±1.5dB.
4. Test date: January 22, 2013
Tested By: Alan Lv

Requirement(s): §15.247(a)(2) specifies that the minimum 6 dB bandwidth shall be at least 500 kHz. In addition, the EBW is required information for subsequent band power measurements. The following procedures can be used to determine the EBW:

Procedures:

1. Set resolution bandwidth (RBW) = 1-5% of DTS BW, not to exceed 100 kHz.
2. Set the video bandwidth (VBW) ≥ 3 x RBW.
3. Detector = Peak.
4. Trace mode = max hold.
5. Sweep = auto couple.
6. Allow the trace to stabilize.
7. Measure the maximum width of the emission that is constrained by the frequencies associated with the two outermost amplitude points (upper and lower) that are attenuated by 6 dB relative to the maximum level measured in the fundamental emission.

Test Result: Pass.

Please refer to the following tables and plots.

Channel	Channel Frequency (MHz)	Data Rate (Mbps)	Measured 6dB Bandwidth (kHz)	FCC Part 15.247 Limit (kHz)
GFSK Transmitting mode				
Low	2402	1	757	> 500
Middle	2440	1	757	> 500
High	2480	1	757	> 500



SIEMIC, INC.

Accessing global markets

Title: RF Test Report for WiFi and BT combo module
Main Model: FLC-CBM202
Serial Model: See P5
To: FCC Part 15.247: 2012, ANSI C63.4: 2009

Report No.: 12021036-FCC-R3
Issue Date: January 24, 2013
Page: 11 of 46
www.siemec.com.cn

Low Channel

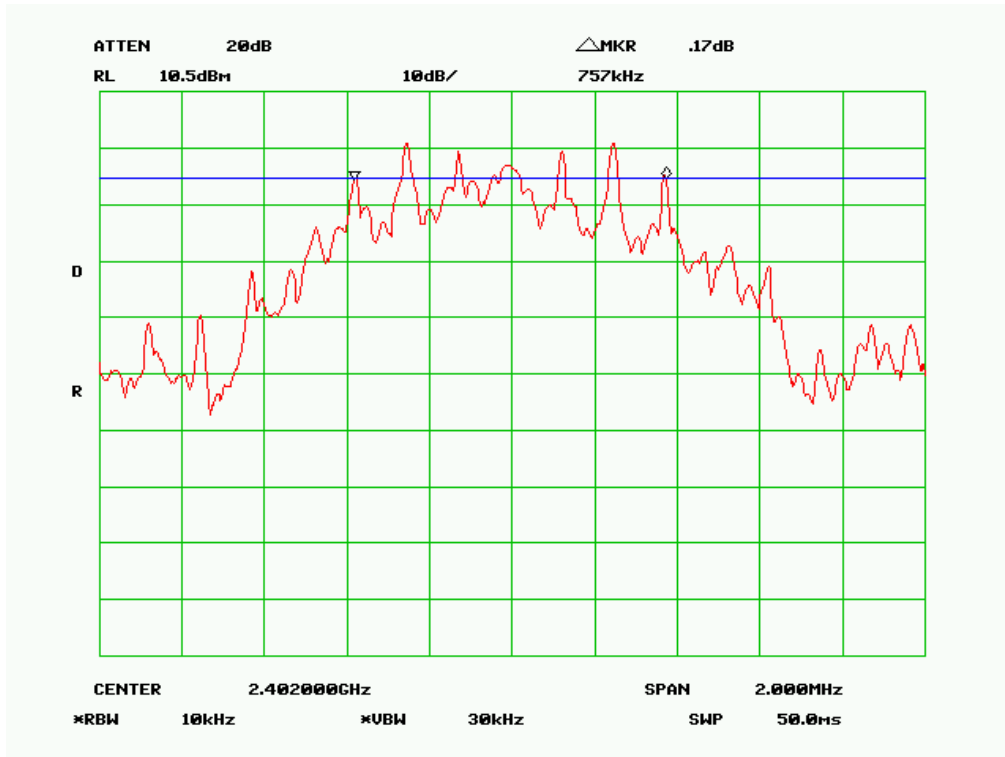

Middle Channel

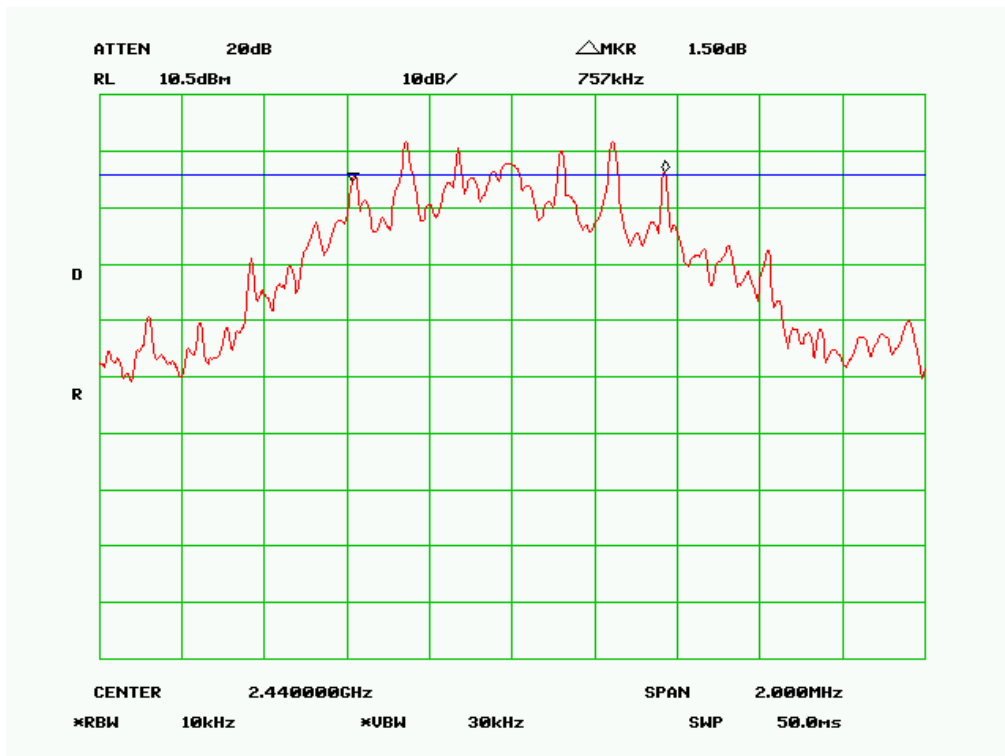



SIEMIC, Inc.

Accessing global markets

Title: RF Test Report for WiFi and BT combo module
Main Model: FLC-CBM202
Serial Model: See P5
To: FCC Part 15.247: 2012, ANSI C63.4: 2009

Report No.: 12021036-FCC-R3
Issue Date: January 24, 2013
Page: 12 of 46
www.siemic.com.cn

High Channel

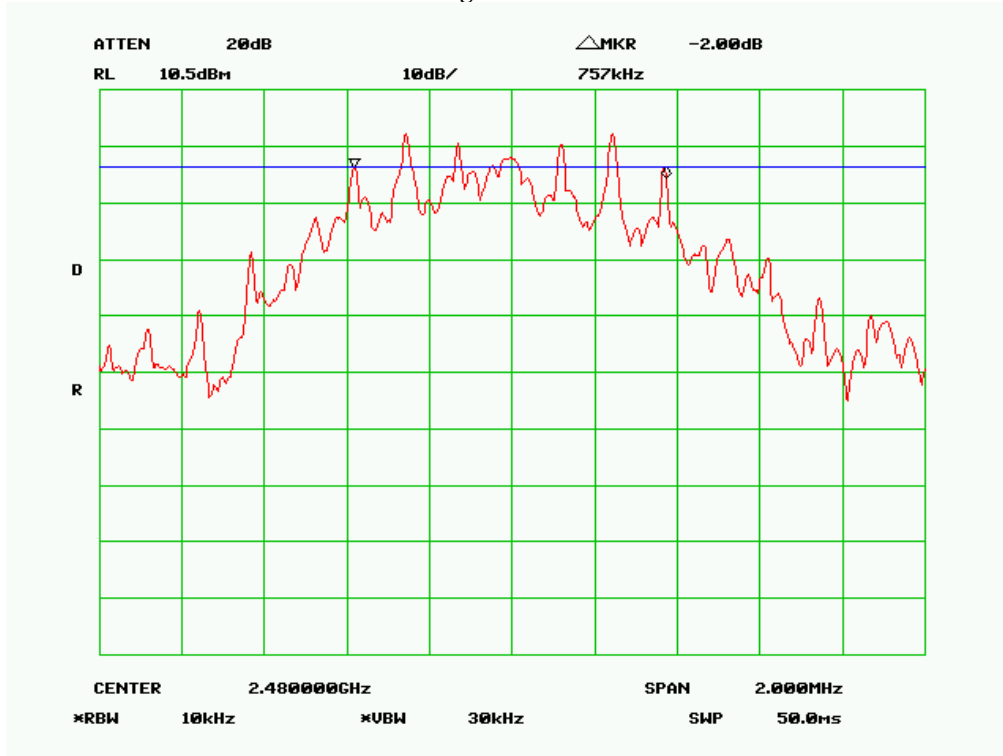

5.3 §15.247(b) (3) - Conducted Maximum Output Power

1. **Conducted Measurement**
EUT was set for low, mid, high channel with modulated mode and highest RF output power.
The spectrum analyzer was connected to the antenna terminal.
2. **Conducted Emissions Measurement Uncertainty**
All test measurements carried out are traceable to national standards. The uncertainty of the measurement at a confidence level of approximately 95% (in the case where distributions are normal), with a coverage factor of 2, in the range 30MHz – 40GHz is ± 1.5 dB.
3. **Environmental Conditions**

Temperature	14°C
Relative Humidity	55%
Atmospheric Pressure	1019mbar
4. Test date : January 22, 2013
Tested By : Alan Lv

Standard Requirement:

Maximum Peak Conducted Output Power Level:

§15.247(b)(3) specifies that the maximum peak conducted output power for DTS transmitters in any of the three authorized frequency bands is 1 watt (30 dBm). The following procedures can be used to determine the maximum peak conducted output power from a DTS EUT using a spectrum analyzer.

Procedures:

Measurement Procedure PK1:

1. Set the RBW \geq DTS bandwidth.
2. Set VBW \geq 3 x RBW.
3. Set span \geq RBW.
4. Sweep time = auto couple.
5. Detector = peak.
6. Trace mode = max hold.
7. Allow trace to fully stabilize.
8. Use peak marker function to determine the peak amplitude level.

Test Result: Pass.

Please refer to the following tables and plots.

Channel	Channel Frequency (MHz)	Data Rate (Mbps)	PK Output Power (dBm)	Limit (dBm)
GFSK Transmitting mode				
Low	2402	1	5.67	30
Middle	2440	1	7.00	30
High	2480	1	6.83	30



SIEMIC, INC.

Accessing global markets

Title: RF Test Report for WiFi and BT combo module
Main Model: FLC-CBM202
Serial Model: See P5
To: FCC Part 15.247: 2012, ANSI C63.4: 2009

Report No.: 12021036-FCC-R3
Issue Date: January 24, 2013
Page: 14 of 46
www.siemic.com.cn

PK Output Power, Low Channel

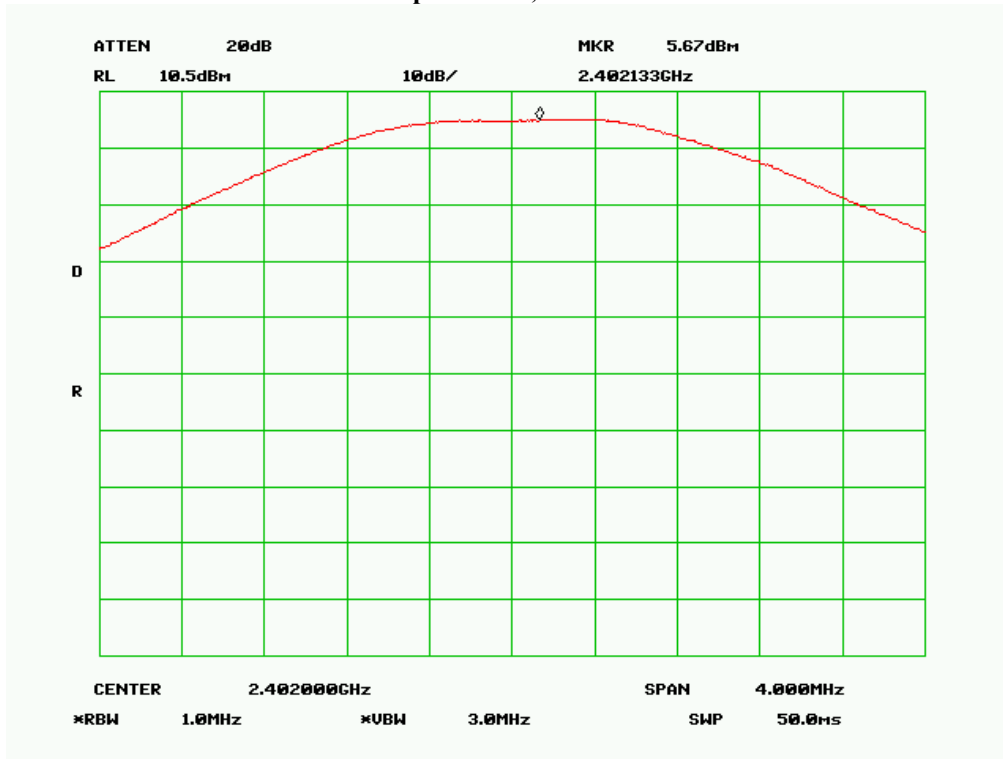

PK Output Power, Middle Channel

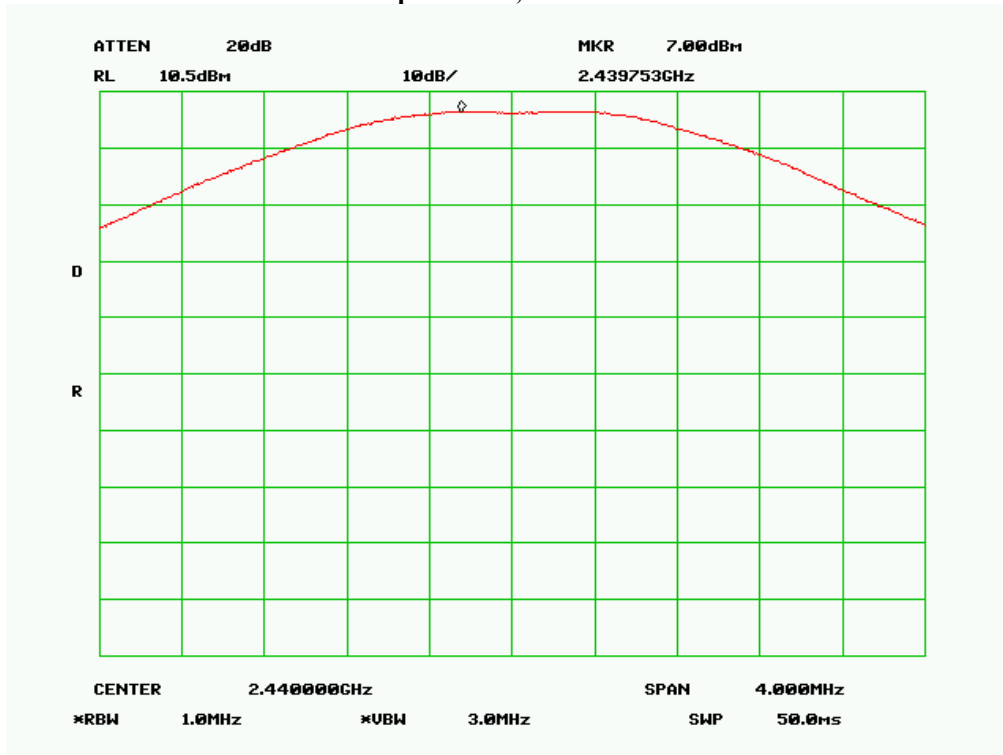



SIEMIC, INC.

Accessing global markets

Title: RF Test Report for WiFi and BT combo module
Main Model: FLC-CBM202
Serial Model: See P5
To: FCC Part 15.247: 2012, ANSI C63.4: 2009

Report No.: 12021036-FCC-R3
Issue Date: January 24, 2013
Page: 15 of 46
www.siemic.com.cn

PK Output Power, High Channel

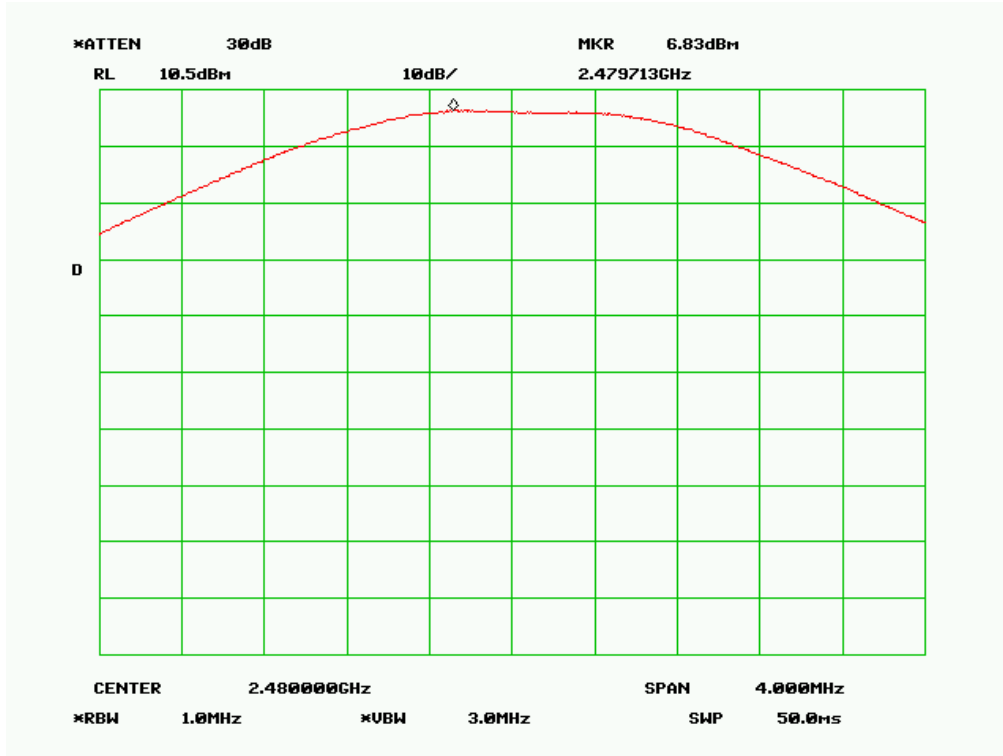

5.4 §15.247(e) - Power Spectral Density

1. **Conducted Measurement**
 EUT was set for low, mid, high channel with modulated mode and highest RF output power.
 The spectrum analyzer was connected to the antenna terminal.
2. **Environmental Conditions**

Temperature	15°C
Relative Humidity	50%
Atmospheric Pressure	1019mbar
3. **Conducted Emissions Measurement Uncertainty**
 All test measurements carried out are traceable to national standards. The uncertainty of the measurement at a confidence level of approximately 95% (in the case where distributions are normal), with a coverage factor of 2, in the range 30MHz – 40GHz is ±1.5dB.
4. **Test date : January 23, 2013**
 Tested By : Alan Lv

Requirement(s): §15.247(e) specifies a conducted power spectral density (PSD) limit of 8 dBm in any 3 kHz band segment within the fundamental EBW during any time interval of continuous transmission. The same method as used to determine the conducted output power shall be used to determine the power spectral density (i.e., if peak-detected fundamental power was measured then use the peak PSD procedure and if average fundamental power was measured then use the average PSD procedure).

Procedures:

Measurement Procedure PKPSD:

1. Set analyzer centre frequency to DTS channel centre frequency.
2. Set the span to 1.5 times the DTS channel bandwidth.
3. Set the RBW \geq 3 kHz.
4. Set the VBW \geq 3 x RBW.
5. Detector = peak.
6. Sweep time = auto couple.
7. Trace mode = max hold.
8. Allow trace to fully stabilize.
9. Use the peak marker function to determine the maximum amplitude level.
10. If measured value exceeds limit, reduce RBW (no less than 3 kHz) and repeat.

Test Result: Pass.

Please refer to the following tables and plots.

Channel	Frequency (MHz)	Data Rate	S.A. Reading (dBm)	Limit (dBm)
GFSK Transmitting mode				
Low	2402	1	-1.00	8
Middle	2440	1	0.50	8
High	2480	1	1.67	8



SIEMIC, INC.

Accessing global markets

Title: RF Test Report for WiFi and BT combo module
Main Model: FLC-CBM202
Serial Model: See P5
To: FCC Part 15.247: 2012, ANSI C63.4: 2009

Report No.: 12021036-FCC-R3
Issue Date: January 24, 2013
Page: 17 of 46
www.siemic.com.cn

Power Spectral Density, Low Channel

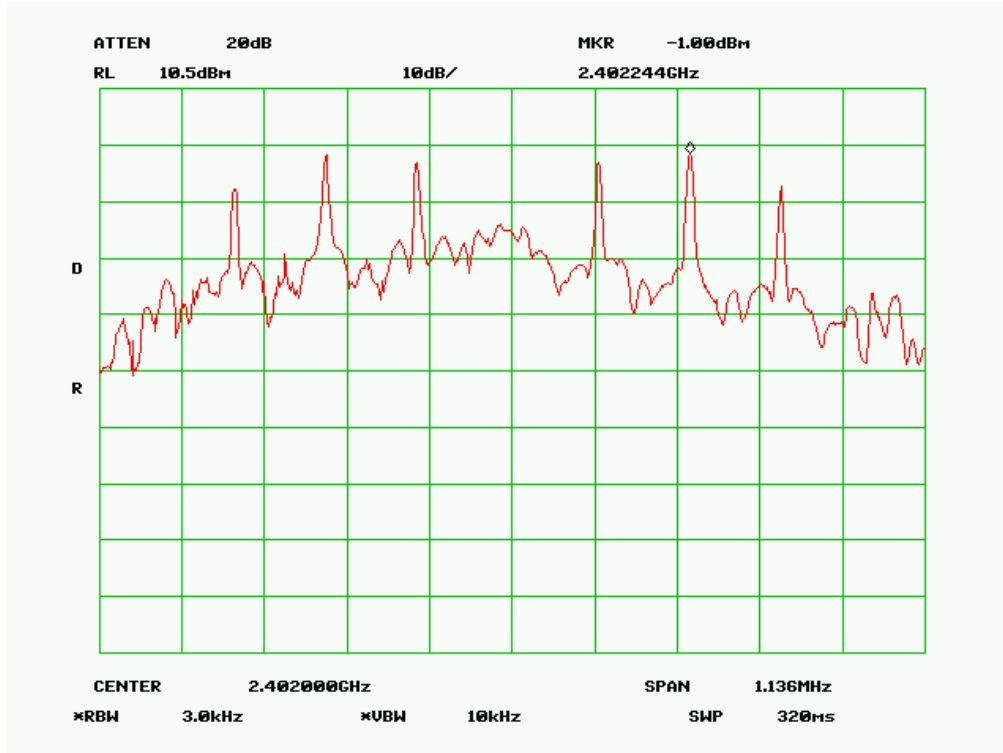

Power Spectral Density, Middle Channel

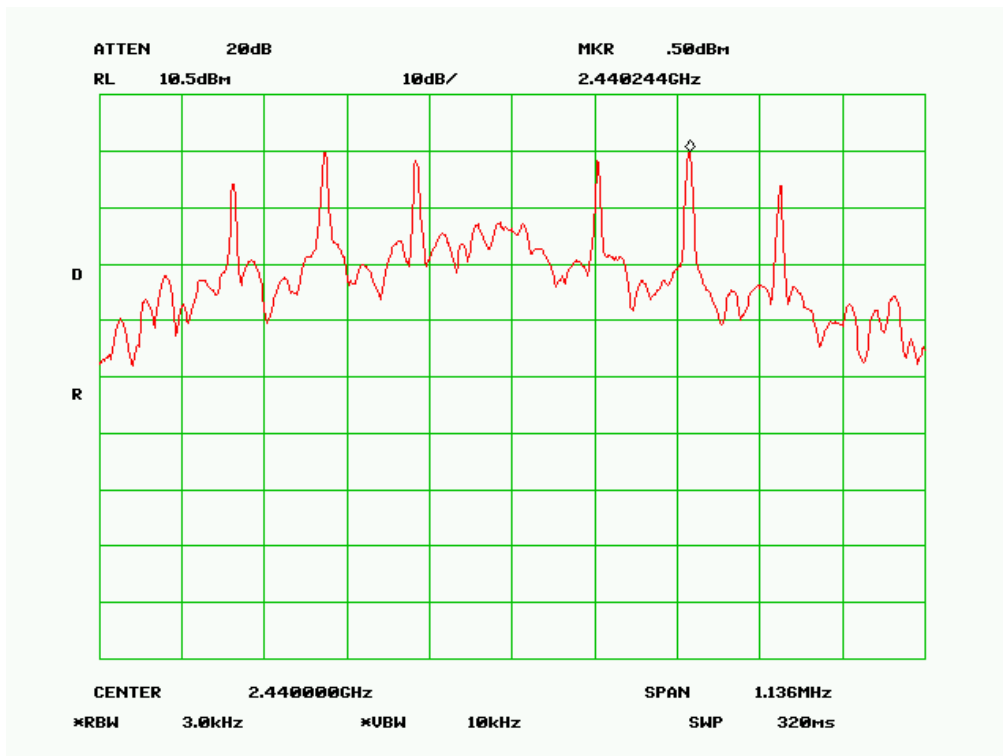



SIEMIC, Inc.

Accessing global markets

Title: RF Test Report for WiFi and BT combo module
Main Model: FLC-CBM202
Serial Model: See P5
To: FCC Part 15.247: 2012, ANSI C63.4: 2009

Report No.: 12021036-FCC-R3
Issue Date: January 24, 2013
Page: 18 of 46
www.siemec.com.cn

Power Spectral Density, High Channel



5.5 §15.247(d) –Band Edge & Conducted Spurious Emissions

1. In any 100 kHz bandwidth outside the frequency band in which the spread spectrum or digitally modulated intentional radiator is operating, the radio frequency power that is produced by the intentional radiator shall be at least 20 dB below that in the 100 kHz bandwidth within the band that contains the highest level of the desired power, based on either an RF conducted or a radiated measurement, provided the transmitter demonstrates compliance with the peak conducted power limits. If the transmitter complies with the conducted power limits based on the use of RMS averaging over a time interval, as permitted under paragraph (b)(3) of this section, the attenuation required under this paragraph shall be 30 dB instead of 20 dB. Attenuation below the general limits specified in §15.209(a) is not required. In addition, radiated emissions which fall in the restricted bands, as defined in §15.205(a), must also comply with the radiated emission limits specified in §15.209(a) (see §15.205(c))

2.

Environmental Conditions	Temperature	15°C
	Relative Humidity	55%
	Atmospheric Pressure	1019mbar

3.

Test date : January 22, 2013
Tested By : Alan Lv

Test Result: Pass.

Requirement(s): §15.247(d) in any 100 kHz bandwidth outside the frequency band in which the spread spectrum or digitally modulated intentional radiator is operating, the radio frequency power that is produced by the intentional radiator shall be at least 20 dB below that in the 100 kHz bandwidth within the band that contains the highest level of the desired power, based on either an RF conducted or a radiated measurement, provided the transmitter demonstrates compliance with the peak conducted power limits. If the transmitter complies with the conducted power limits based on the use of RMS averaging over a time interval, as permitted under paragraph (b)(3) of this section, the attenuation required under this paragraph shall be 30 dB instead of 20 dB.

Procedures:

1. Set start frequency to DTS channel edge frequency.
2. Set stop frequency so as to encompass the spectrum to be examined.
3. Set RBW = 100 kHz.
4. Set VBW ≥ 300 kHz.
5. Detector = peak.
6. Trace Mode = max hold.
7. Sweep = auto couple.
8. Allow the trace to stabilize (this may take some time, depending on the extent of the span).
9. Use peak marker function to determine maximum amplitude of all unwanted emissions within any 100 kHz bandwidth.

Ensure that the amplitude of all unwanted emissions outside of the authorized frequency band (excluding restricted frequency bands) are attenuated by at least the minimum requirements. Report the three highest emissions relative to the limit.

Please refer to the following tables and plots.

Band Edge (MHz)	Delta Peak to band emission (dB)	Limit (dB)
GFSK Transmitting mode		
2400.0	44.00	20
2483.5	47.84	20



SIEMIC, INC.

Accessing global markets

Title: RF Test Report for WiFi and BT combo module
Main Model: FLC-CBM202
Serial Model: See P5
To: FCC Part 15.247: 2012, ANSI C63.4: 2009

Report No.: 12021036-FCC-R3
Issue Date: January 24, 2013
Page: 20 of 46
www.siemic.com.cn

Band Edge, Left Side

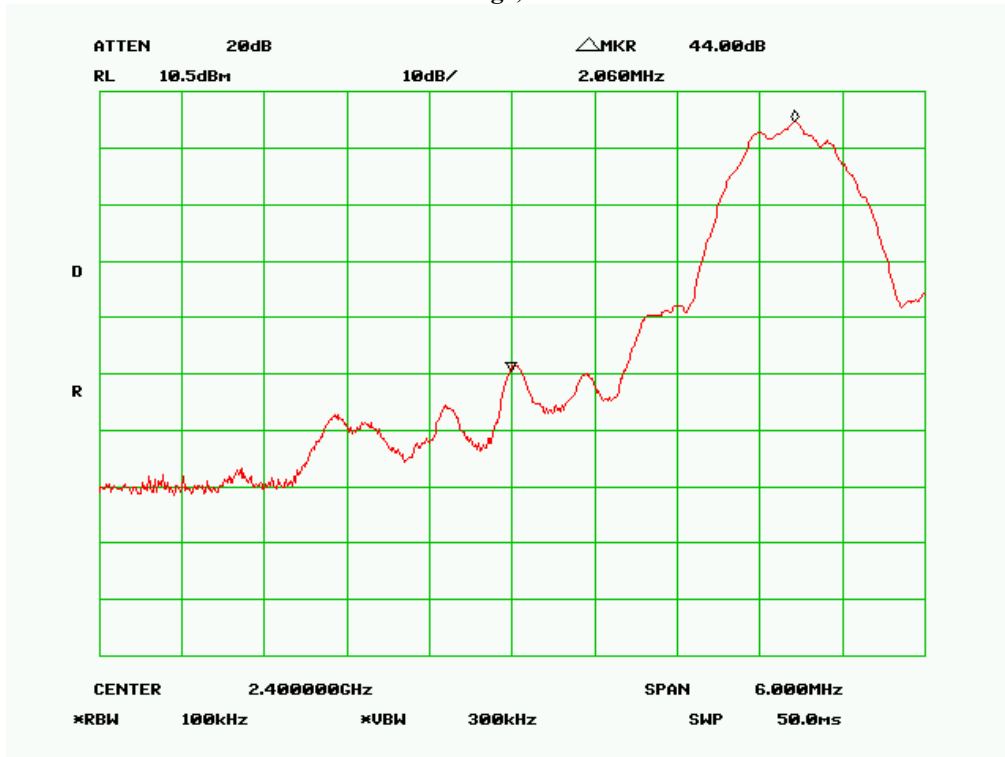

Band Edge, Right Side

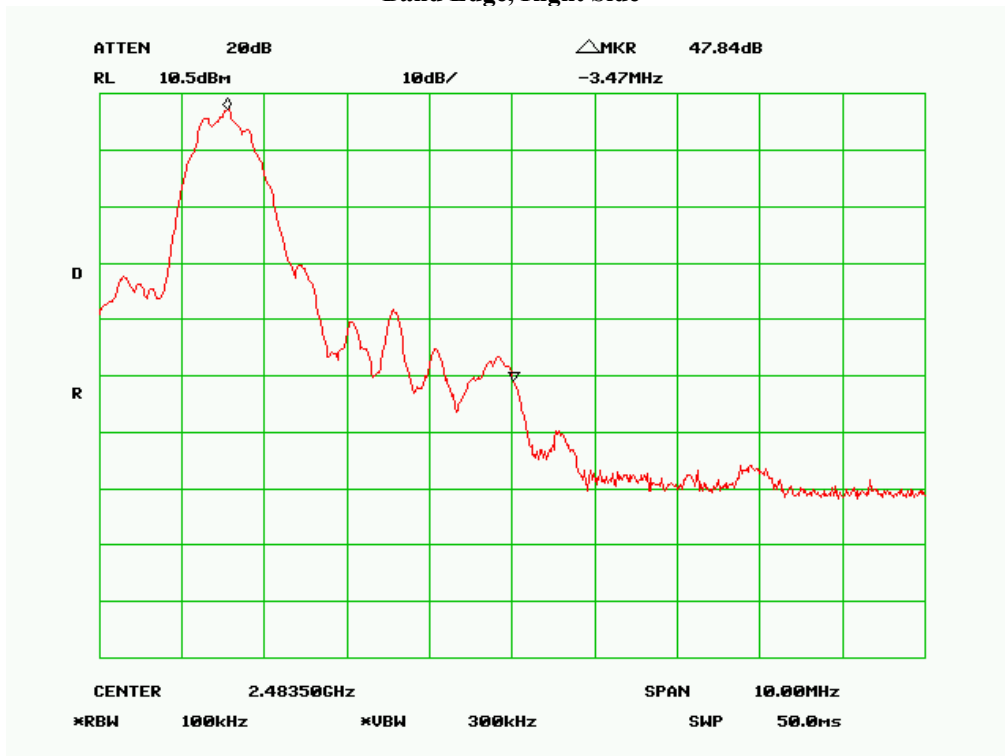

Antenna Port Conducted Spurious Emissions

Please refer to the following plots.

Low Channel

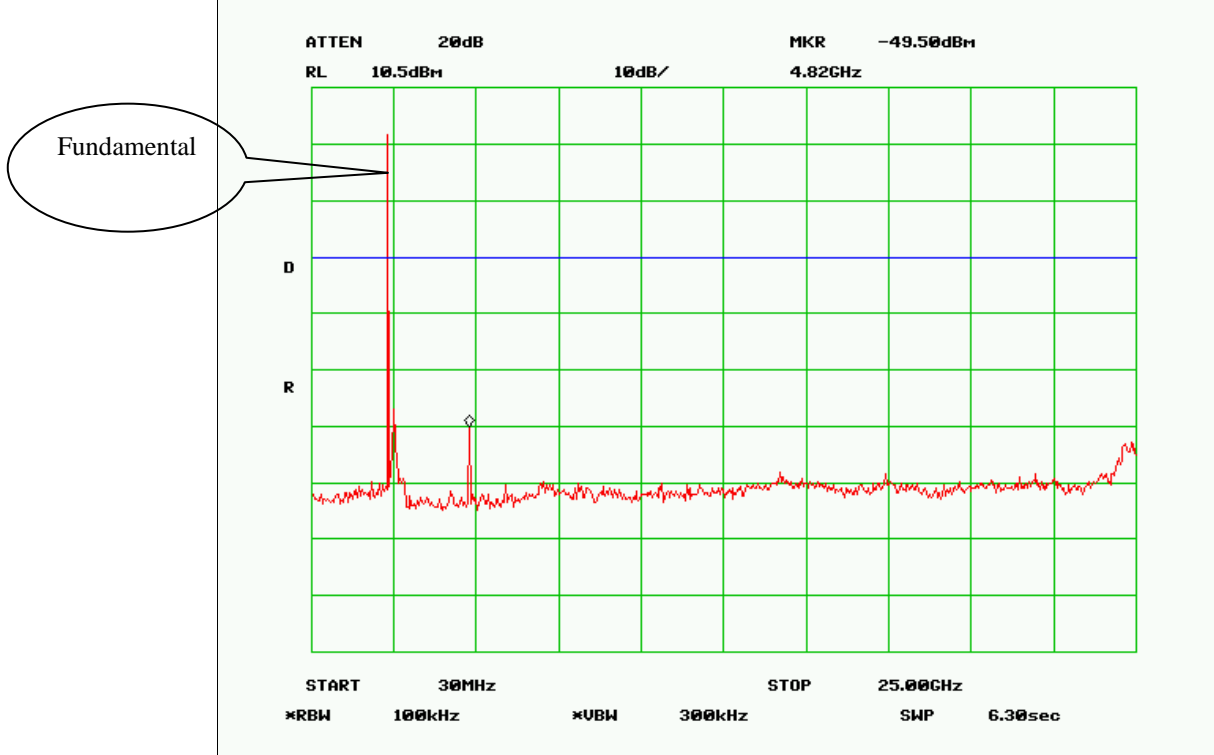

Middle Channel

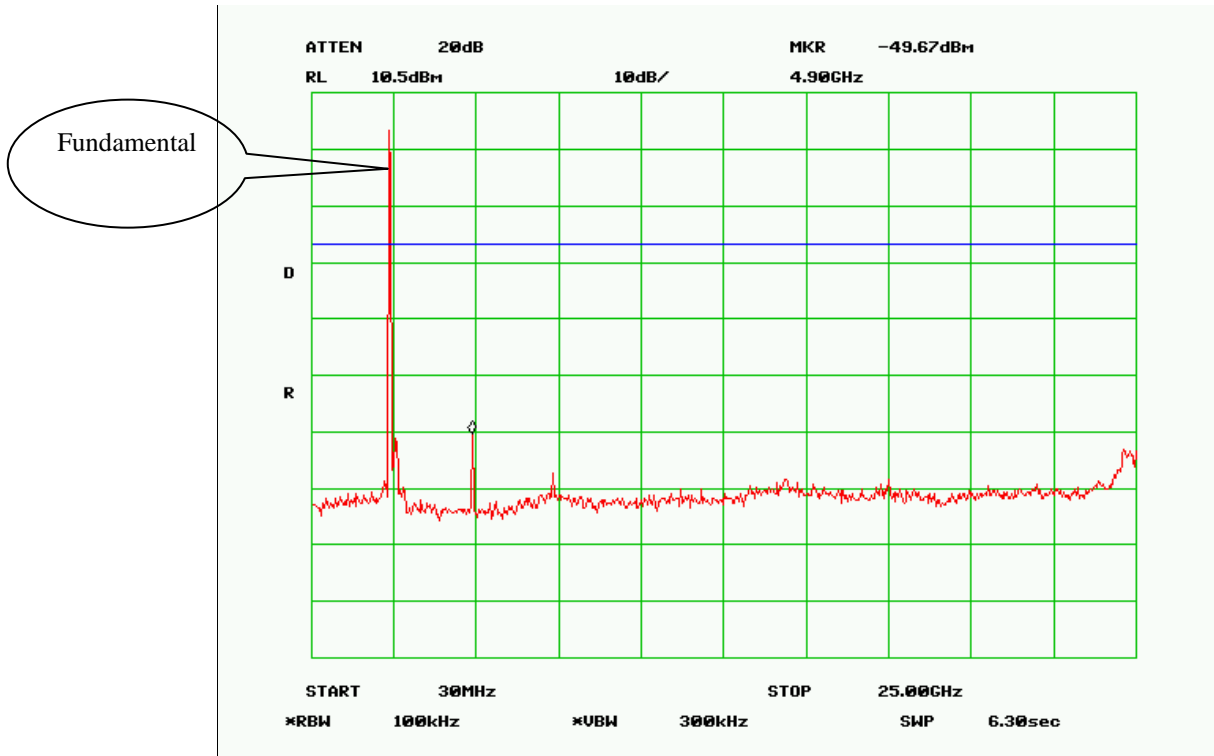



SIEMIC, INC.

Accessing global markets

Title: RF Test Report for WiFi and BT combo module
Main Model: FLC-CBM202
Serial Model: See P5
To: FCC Part 15.247: 2012, ANSI C63.4: 2009

Report No.: 12021036-FCC-R3
Issue Date: January 24, 2013
Page: 22 of 46
www.siemic.com.cn

High Channel

Fundamental

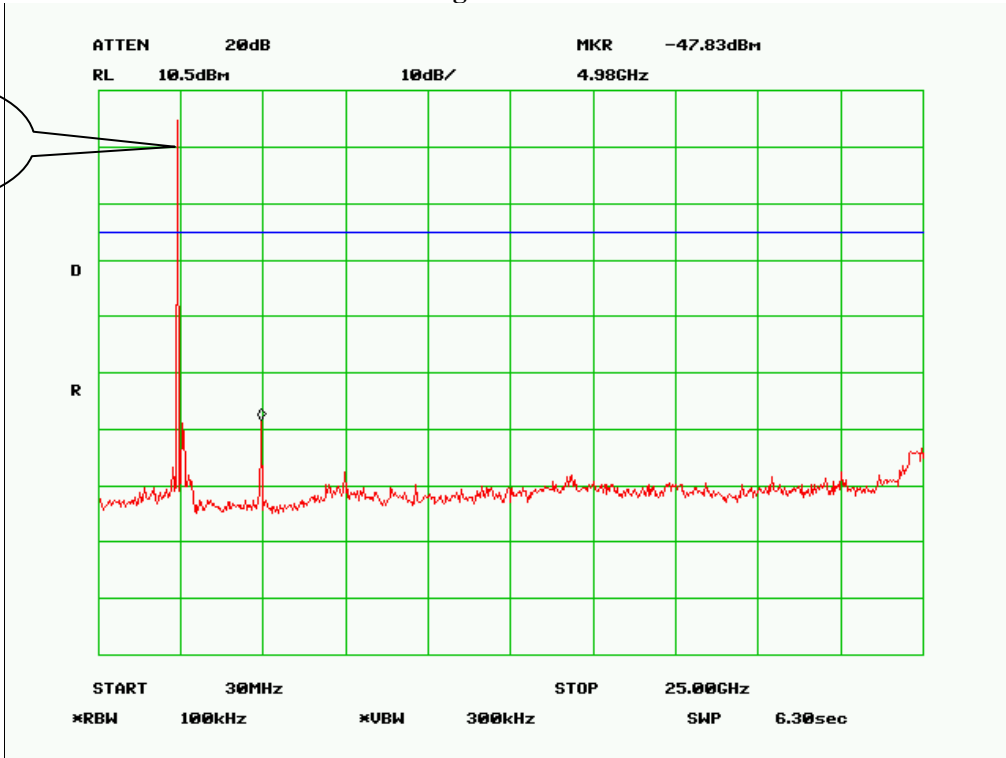

5.6 §15.207 (a) - AC Power Line Conducted Emissions

Requirement:

Frequency of emission (MHz)	Conducted limit (dB μ V)	
	Quasi-peak	Average
0.15–0.5	66 to 56*	56 to 46*
0.5–5	56	46
5–30	60	50

*Decreases with the logarithm of the frequency.

Procedures:

1. All possible modes of operation were investigated. Only the 6 worst case emissions measured, using the correct CISPR and Average detectors, are reported. All other emissions were relatively insignificant.
2. A "-ve" margin indicates a PASS as it refers to the margin present below the limit line at the particular frequency.
3. Conducted Emissions Measurement Uncertainty
All test measurements carried out are traceable to national standards. The uncertainty of the measurement at a confidence level of approximately 95% (in the case where distributions are normal), with a coverage factor of 2, in the range 9kHz – 30MHz (Average & Quasi-peak) is ± 3.5 dB.
4. Environmental Conditions

Temperature	15°C
Relative Humidity	50%
Atmospheric Pressure	1019mbar
5. Test date : January 23, 2013
Tested By : Alan Lv

Test Result: Pass

Test Mode:	GFSK Transmitting
-------------------	--------------------------

Peak Detector  **Quasi Peak Limit** 
Average Detector  **Average Limit** 

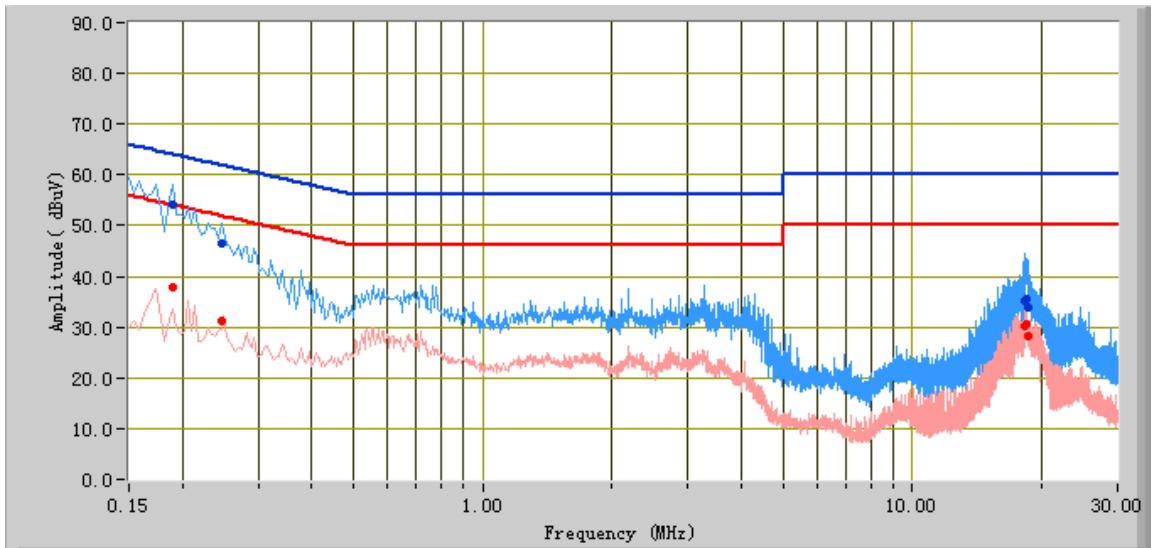

Test Data

Phase Line Plot at 120Vac, 60Hz

Frequency (MHz)	Quasi Peak (dBµV)	Limit (dBµV)	Margin (dB)	Average (dBµV)	Limit (dBµV)	Margin (dB)	Factors (dB)
0.19	54.13	64.04	-9.90	37.71	54.04	-16.33	11.64
0.25	46.44	61.89	-15.45	31.29	51.89	-20.60	11.46
18.27	35.19	60.00	-24.81	30.11	50.00	-19.89	11.49
18.18	35.32	60.00	-24.68	30.12	50.00	-19.88	11.49
18.39	35.54	60.00	-24.46	30.70	50.00	-19.30	11.50
18.56	33.90	60.00	-26.10	28.25	50.00	-21.75	11.50

Test Mode: GFSK Transmitting

Peak Detector  **Quasi Peak Limit** 
Average Detector  **Average Limit** 

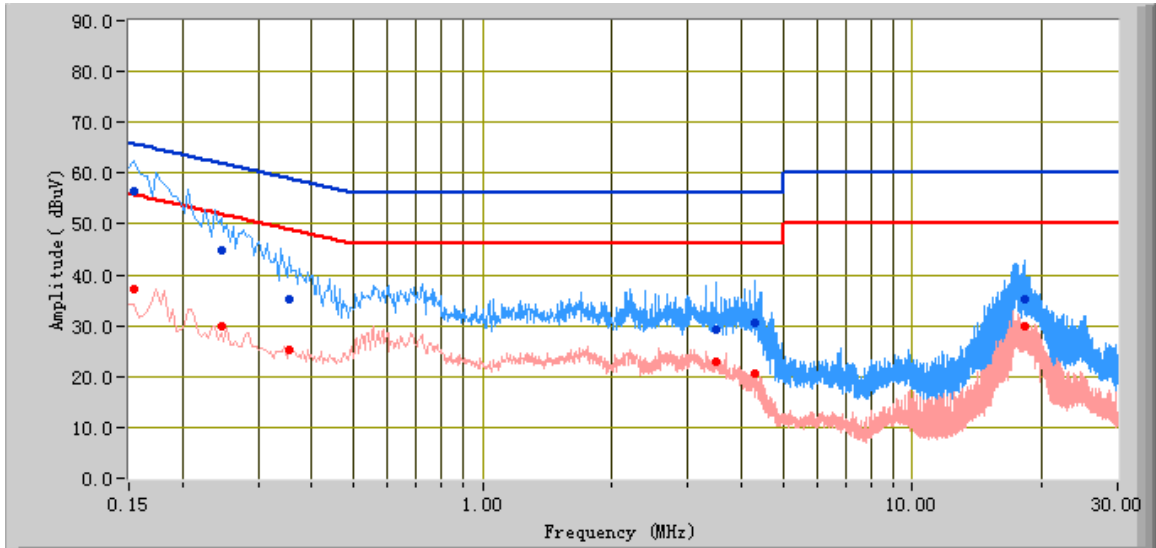

Test Data

Phase Neutral Plot at 120Vac, 60Hz

Frequency (MHz)	Quasi Peak (dBµV)	Limit (dBµV)	Margin (dB)	Average (dBµV)	Limit (dBµV)	Margin (dB)	Factors (dB)
0.15	56.30	65.78	-9.48	37.35	55.78	-18.43	12.15
0.25	44.72	61.89	-17.18	29.97	51.89	-21.92	11.46
0.35	35.31	58.87	-23.55	25.30	48.87	-23.57	11.29
4.31	30.45	56.00	-25.55	20.58	46.00	-25.42	10.94
18.21	35.37	60.00	-24.63	29.74	50.00	-20.26	11.51
3.49	29.21	56.00	-26.79	23.04	46.00	-22.96	10.94

Test Mode:	GFSK Transmitting
-------------------	--------------------------

Below 1GHz

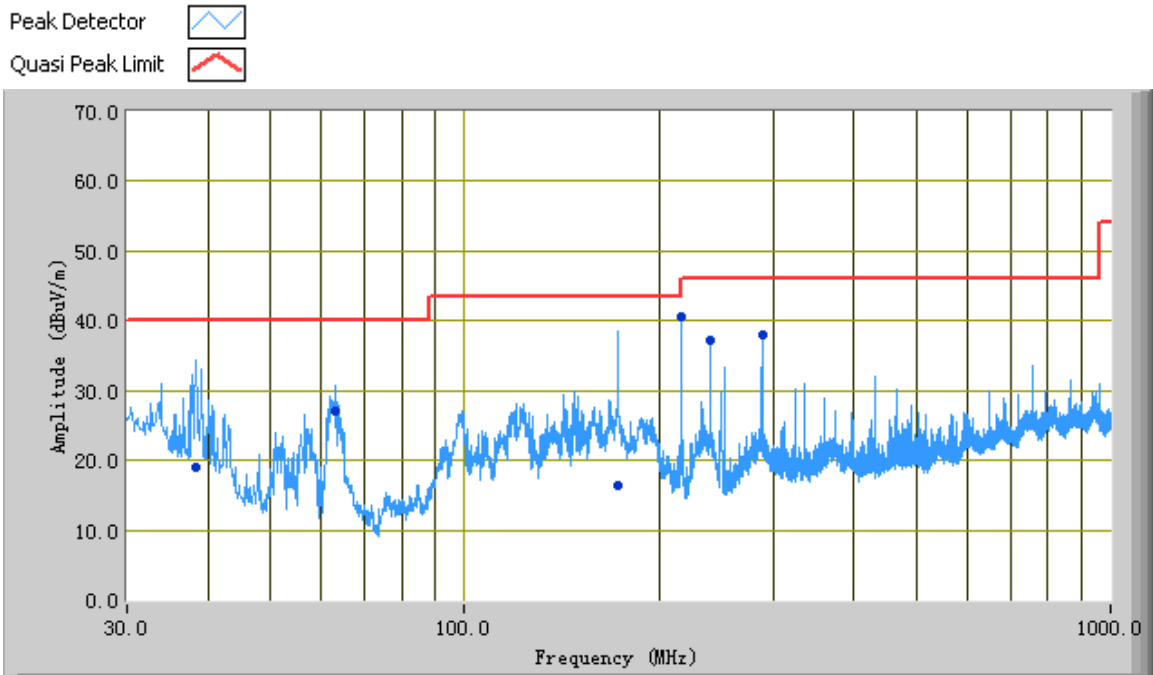

Test Data

Polarity Horizontal & Vertical @3m

Frequency (MHz)	Quasi Peak (dBµV/m)	Azimuth	Polarity (H/V)	Height (cm)	Factors (dB)	Limit (dBµV/m)	Margin (dB)
172.94	16.30	117.00	H	137.00	-32.23	43.50	-27.20
38.45	19.07	24.00	H	234.00	-26.60	40.00	-20.93
216.44	40.53	234.00	H	129.00	-34.02	46.00	-5.47
288.57	38.06	237.00	H	100.00	-32.26	46.00	-7.94
240.00	37.26	241.00	H	109.00	-32.68	46.00	-8.74
63.05	27.14	229.00	V	112.00	-37.96	40.00	-12.86

Test Mode:	GFSK Transmitting
-------------------	--------------------------

Above 1 GHz

Low Channel (2402 MHz)

Frequency (MHz)	S.A. Reading (dBµV)	Detector (PK/AV)	Direction (degree)	Height (cm)	Polarity (H/V)	Ant. Factor (dB/m)	Cable Loss (dB)	Pre-Amp. Gain (dB)	Cord. Amp. (dBµV/m)	Limit (dBµV/m)	Margin (dB)
4804.00	76.34	PK	124.00	130.00	V	32.70	12.80	57.00	64.84	74.00	-9.16
4804.00	50.24	AV	124.00	130.00	V	32.70	12.80	57.00	38.74	54.00	-15.26
2387.00	70.23	PK	256.00	110.00	V	30.10	7.20	57.00	50.53	74.00	-23.47
2387.00	51.16	AV	256.00	110.00	V	30.10	7.20	57.00	31.46	54.00	-22.54
4804.00	75.42	PK	315.00	120.00	H	32.70	12.80	57.00	63.92	74.00	-10.08
4804.00	52.67	AV	315.00	120.00	H	32.70	12.80	57.00	41.17	54.00	-12.83
2387.00	69.26	PK	108.00	120.00	H	30.10	7.20	57.00	49.56	74.00	-24.44
2387.00	50.21	AV	108.00	120.00	H	30.10	7.20	57.00	30.51	54.00	-23.49

Middle Channel (2440 MHz)

Frequency (MHz)	S.A. Reading (dBµV)	Detector (PK/AV)	Direction (degree)	Height (cm)	Polarity (H/V)	Ant. Factor (dB/m)	Cable Loss (dB)	Pre-Amp. Gain (dB)	Cord. Amp. (dBµV/m)	Limit (dBµV/m)	Margin (dB)
4880.00	75.42	PK	124.00	120.00	V	32.80	12.80	57.00	64.02	74.00	-9.98
4880.00	51.89	AV	124.00	120.00	V	32.80	12.80	57.00	40.49	54.00	-13.51
7320.00	67.16	PK	215.00	110.00	V	35.60	15.90	58.00	60.66	74.00	-13.34
7320.00	50.52	AV	215.00	110.00	V	35.60	15.90	58.00	44.02	54.00	-9.98
4880.00	72.49	PK	134.00	150.00	H	32.80	12.80	57.00	61.09	74.00	-12.91
4880.00	50.21	AV	134.00	150.00	H	32.80	12.80	57.00	38.81	54.00	-15.19
7320.00	69.36	PK	51.00	110.00	H	35.60	15.90	58.00	62.86	74.00	-11.14
7320.00	50.16	AV	51.00	110.00	H	35.60	15.90	58.00	43.66	54.00	-10.34

High Channel (2480 MHz)

Frequency (MHz)	S.A. Reading (dBµV)	Detector (PK/AV)	Direction (degree)	Height (cm)	Polarity (H/V)	Ant. Factor (dB/m)	Cable Loss (dB)	Pre-Amp. Gain (dB)	Cord. Amp. (dBµV/m)	Limit (dBµV/m)	Margin (dB)
4960.00	75.26	PK	120.00	110.00	V	32.70	12.80	57.00	63.76	74.00	-10.24
4960.00	51.42	AV	120.00	110.00	V	32.70	12.80	57.00	39.92	54.00	-14.08
2489.00	69.35	PK	114.00	120.00	V	30.10	10.16	57.00	52.61	74.00	-21.39
2489.00	49.18	AV	114.00	120.00	V	30.10	10.16	57.00	32.44	54.00	-21.56
4960.00	74.59	PK	246.00	130.00	H	32.70	12.80	57.00	63.09	74.00	-10.91
4960.00	51.34	AV	246.00	130.00	H	32.70	12.80	57.00	39.84	54.00	-14.16
2485.00	70.12	PK	152.00	110.00	H	30.10	7.20	57.00	50.42	74.00	-23.58
2485.00	50.35	AV	152.00	110.00	H	30.10	7.20	57.00	30.65	54.00	-23.35

Annex A. TEST INSTRUMENT & METHOD

Annex A.i. TEST INSTRUMENTATION & GENERAL PROCEDURES

Instrument	Model	Serial #	Calibration Date	Calibration Due Date
AC Line Conducted Emissions				
R&S EMI Test Receiver	ESPI3	101216	10/27/2012	10/26/2013
ROHDE&SCHWARZ V-LISN	ESH3-Z5	838979/005	10/27/2012	10/26/2013
Com-Power Transient Limiter	LIT-153	531021	11/04/2012	11/03/2013
SIEMIC Labview Conducted Emissions software	V1.0	N/A	N/A	N/A
Radiated Emissions				
Hp Spectrum Analyzer	8563E	3821A09023	01/10/2013	01/09/2014
R&S EMI Receiver	ESPI3	101216	10/27/2012	10/26/2013
Antenna (30MHz~6GHz)	JB6	A121411	12/27/2012	12/26/2013
EMCO Horn Antenna	3115	N/A	10/30/2012	10/29/2013
A- INFOMW Antenna (1 ~18GHz)	JXTXLB-10180	J2031081120092	06/25/2012	06/24/2013
Horn Antenna (18~40GHz)	AH-840	101013	04/22/2012	04/21/2013
Microwave Pre-Amp (18~40GHz)	PA-840	181250	05/30/2012	05/29/2013
Hp Agilent Pre-Amplifier	8447F	1937A01160	11/04/2012	11/03/2013
MITEQ Pre-Amplifier (0.1 ~ 18GHz)	AMF-7D-00101800-30-10P	1451710	11/04/2012	11/03/2013
Universal Radio Communication Tester	CMU200	104031	10/27/2012	10/26/2013
Chamber	3m	N/A	04/13/2012	04/12/2013
SIEMIC Labview Radiated Emissions software	V1.0	N/A	N/A	N/A

Annex A.ii. CONDUCTED EMISSIONS TEST DESCRIPTION

Test Set-up

1. The EUT and supporting equipment were set up in accordance with the requirements of the standard on top of a 1.5m x 1m x 0.8m high, non-metallic table, as shown in Annex B.
2. The power supply for the EUT was fed through a 50Ω/50μH EUT LISN, connected to filtered mains.
3. The RF OUT of the EUT LISN was connected to the EMI test receiver via a low-loss coaxial cable.
4. All other supporting equipments were powered separately from another main supply.

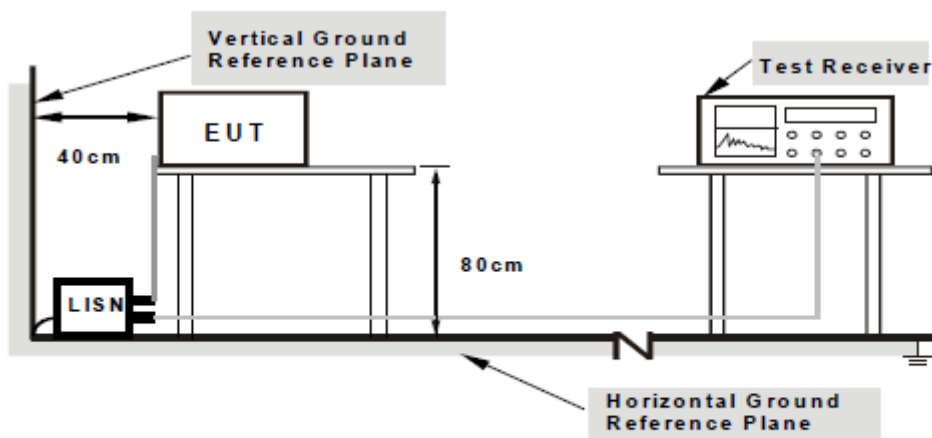

**Note: 1. Support units were connected to second LISN.
 2. Both of LISNs (AMN) are 80cm from EUT and at least 80cm from other units and other metal planes support units.**

For the actual test configuration, please refer to the related item – Photographs of the Test Configuration1.

Test Method

1. The EUT was switched on and allowed to warm up to its normal operating condition.
2. A scan was made on the NEUTRAL line (for AC mains) or Earth line (for DC power) over the required frequency range using an EMI test receiver.
3. High peaks, relative to the limit line, were then selected.
4. The EMI test receiver was then tuned to the selected frequencies and the necessary measurements made with a receiver bandwidth setting of 10 KHz. For FCC tests, only Quasi-peak measurements were made; while for CISPR/EN tests, both Quasi-peak and Average measurements were made.
5. Steps 2 to 4 were then repeated for the LIVE line (for AC mains) or DC line (for DC power).

Description of Conducted Emission Program

This EMC Measurement software run LabView automation software and offers a common user interface for electromagnetic interference (EMI) measurements. This software is a modern and powerful tool for controlling and monitoring EMI test receivers and EMC test systems. It guarantees reliable collection, evaluation, and documentation of measurement results. Basically, this program will run a pre-scan measurement before it proceeds with the final measurement. The pre-scan routine will run the common scan range from 150 kHz to 30 MHz; the program will first start a peak and average scan on selectable measurement time and step size. After the program complete the pre-scan, this program will perform the Quasi Peak and Average measurement, based on the pre-scan peak data reduction result.

Sample Calculation Example

At 20 MHz

limit = 250 μ V = 47.96 dB μ V

Transducer factor of LISN, pulse limiter & cable loss at 20 MHz = 11.20 dB

Q-P reading obtained directly from EMI Receiver = 40.00 dB μ V
(Calibrated for system losses)

Therefore, Q-P margin = 47.96 – 40.00 = 7.96 i.e. **7.96 dB below limit**

Annex A. iii RADIATED EMISSIONS TEST DESCRIPTION

EUT Characterisation

EUT characterisation, over the frequency range from 30MHz to 10th Harmonic , was done in order to minimise radiated emissions testing time while still maintaining high confidence in the test results.

The EUT was placed in the chamber, at a height of about 0.8m on a turntable. Its radiated emissions frequency profile was observed, using a spectrum analyzer /receiver with the appropriate broadband antenna placed 3m away from the EUT. Radiated emissions from the EUT were maximised by rotating the turntable manually, changing the antenna polarisation and manipulating the EUT cables while observing the frequency profile on the spectrum analyzer / receiver. Frequency points at which maximum emissions occurred, clock frequencies and operating frequencies were then noted for the formal radiated emissions test at the Open Area Test Site (OATS).

Test Set-up

1. The EUT and supporting equipment were set up in accordance with the requirements of the standard on top of a 1.5m X 1.0m X 0.8m high, non-metallic table.
2. The filtered power supply for the EUT and supporting equipment were tapped from the appropriate power sockets located on the turntable.
3. The relevant broadband antenna was set at the required test distance away from the EUT and supporting equipment boundary.

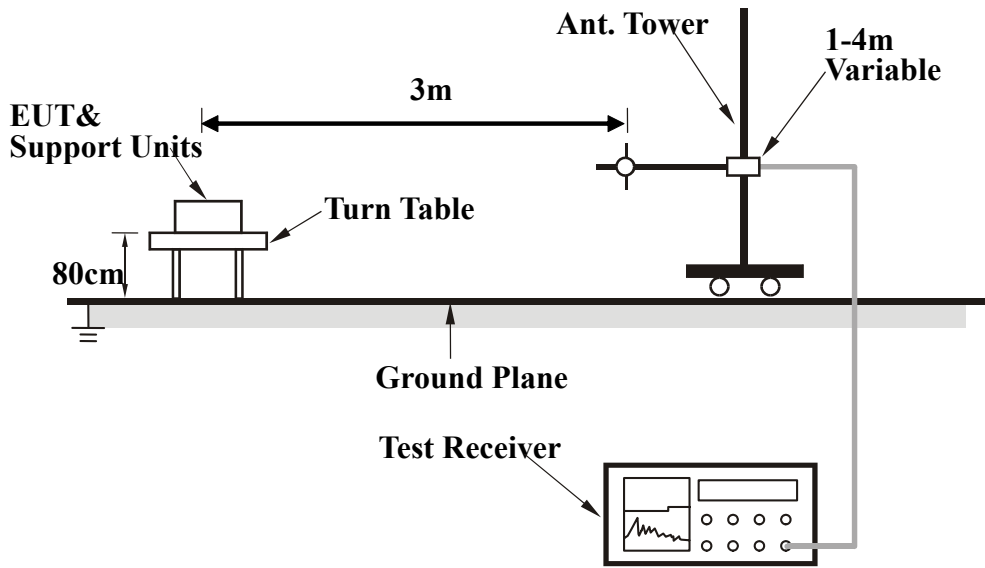

Test Method

The following procedure was performed to determine the maximum emission axis of EUT:

1. With the receiving antenna is H polarization, rotate the EUT in turns with three orthogonal axes to determine the axis of maximum emission.
2. With the receiving antenna is V polarization, rotate the EUT in turns with three orthogonal axes to determine the axis of maximum emission.
3. Compare the results derived from above two steps. So, the axis of maximum emission from EUT was determined and the configuration was used to perform the final measurement.

Final Radiated Emission Measurement

1. Setup the configuration according to figure 1. Turn on EUT and make sure that it is in normal function.
2. For emission frequencies measured below 1 GHz, a pre-scan is performed in a shielded chamber to determine the accurate frequencies of higher emissions will be checked on a open test site. As the same purpose, for emission frequencies measured above 1 GHz, a pre-scan also be performed with a 1 meter measuring distance before final test.
3. For emission frequencies measured below and above 1 GHz, set the spectrum analyzer on a 100 kHz and 1 MHz resolution bandwidth respectively for each frequency measured in step 2.
4. The search antenna is to be raised and lowered over a range from 1 to 4 meters in horizontally polarized orientation. Position the highness when the highest value is indicated on spectrum analyzer, then change the orientation of EUT on test table over a range from 0 ° to 360 ° with a speed as slow as possible, and keep the azimuth that highest emission is indicated on the spectrum analyzer. Vary the antenna position again and record the highest value as a final reading.
5. Repeat step 4 until all frequencies need to be measured were complete.
6. Repeat step 5 with search antenna in vertical polarized orientations.

During the radiated emission test, the Spectrum Analyzer was set with the following configurations:

Frequency Band (MHz)	Function	Resolution bandwidth	Video Bandwidth
30 to 1000	Peak	100 kHz	100 kHz
Above 1000	Peak	1 MHz	1 MHz
	Average	1 MHz	10 Hz

Sample Calculation Example

The field strength is calculated by adding the Antenna Factor and Cable Factor, and subtracting the Amplifier Gain (if any) from the measured reading. For the limit is employed average value, therefore the peak value can be transferred to average value by subtracting the duty factor. The basic equation with a sample calculation is as follows:

$$\text{Peak} = \text{Reading} + \text{Corrected Factor}$$

where

$$\text{Corr. Factor} = \text{Antenna Factor} + \text{Cable Factor} - \text{Amplifier Gain (if any)}$$

And the average value is

$$\text{Average} = \text{Peak Value} + \text{Duty Factor or}$$

$$\text{Set RBW} = 1\text{MHz, VBW} = 10\text{Hz.}$$

Note :

If the measured frequencies are fall in the restricted frequency band, the limit employed must be quasi peak value when frequencies are below or equal to 1 GHz. And the measuring instrument is set to quasi peak detector function.

Annex B. EUT AND TEST SETUP PHOTOGRAPHS

Annex B.i. Photograph 1: EUT External Photo

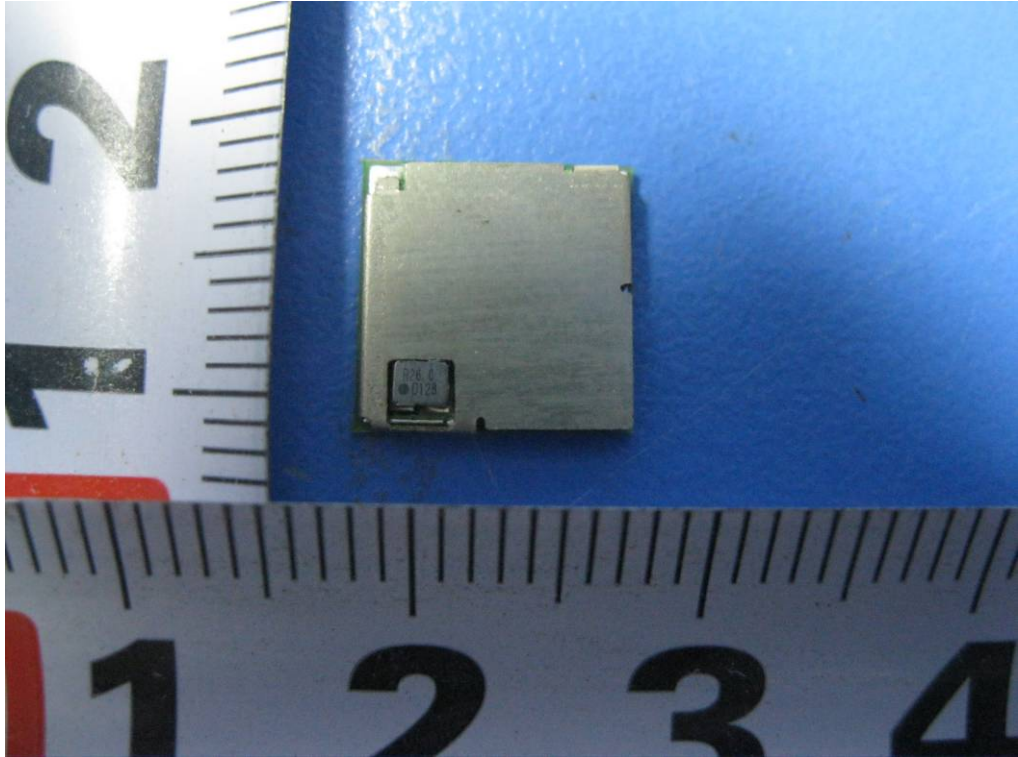

EUT - Front View

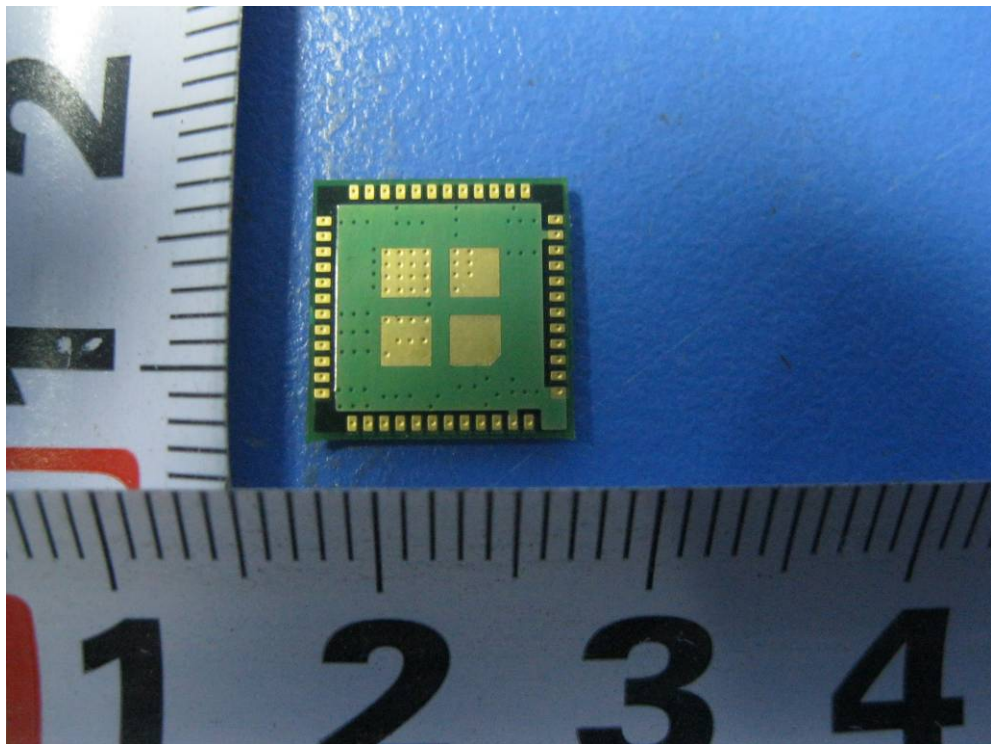

EUT - Rear View

Annex B.ii. Photograph 2: EUT Internal Photo

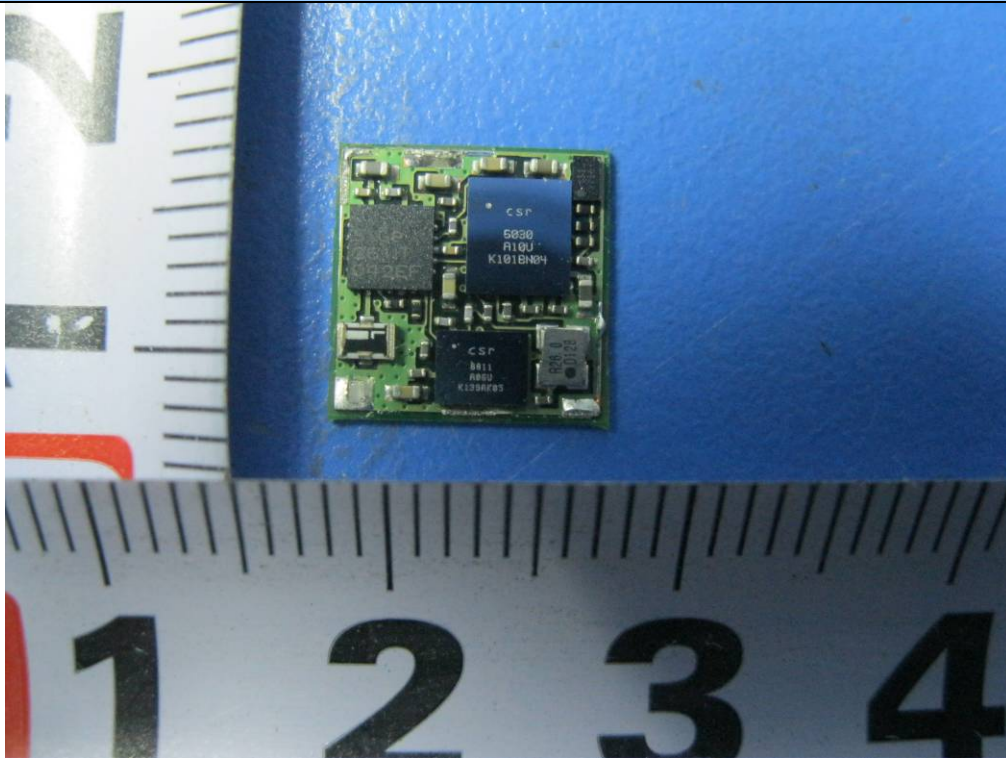

Uncover Without Shielding - Front View

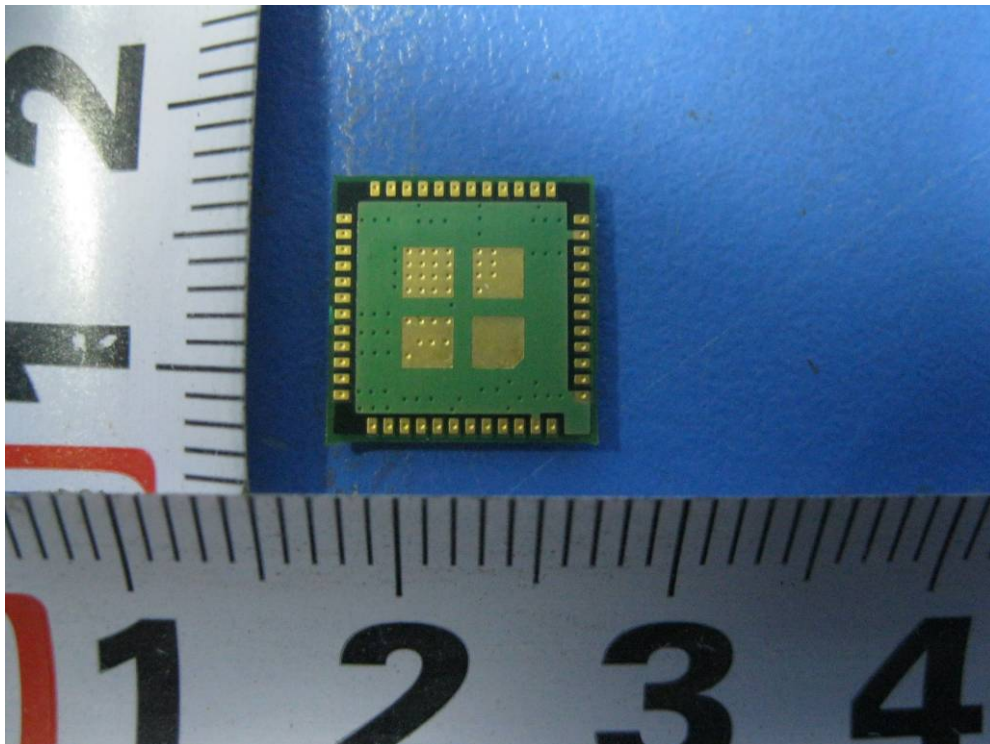

Uncover Without Shielding – Rear View

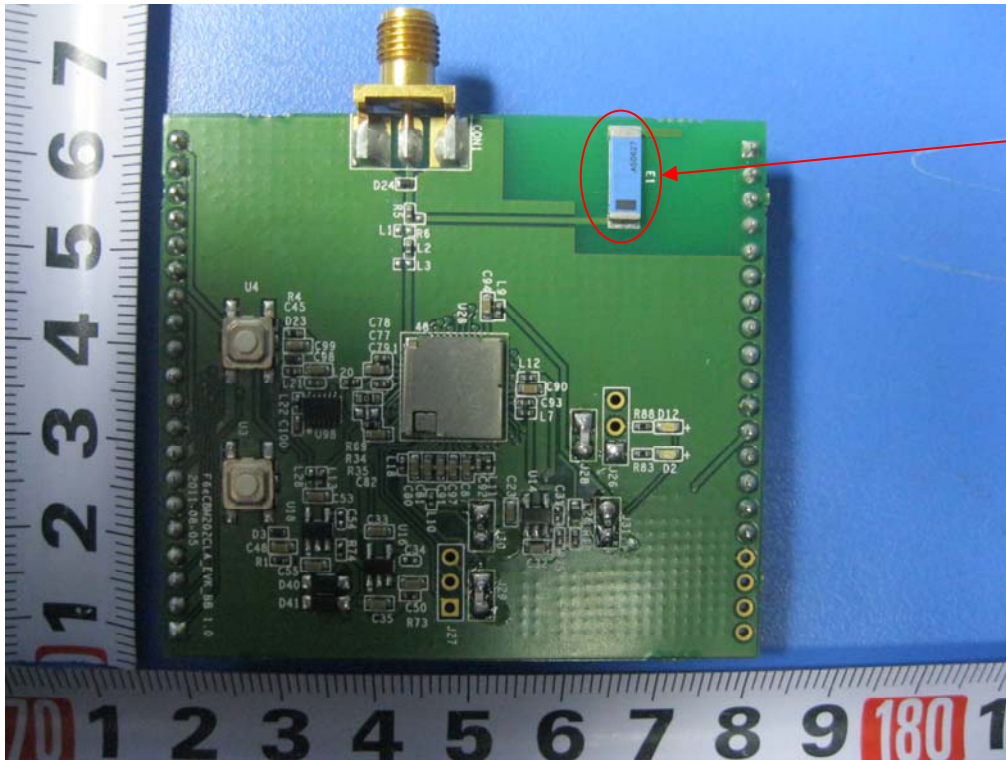

Bluetooth & WIFI Antenna

Antenna – Front View

Annex B.iii. Photograph 3: Test Setup Photo



Conducted Emissions Test Setup Front View



Conducted Emissions Test Setup Side View

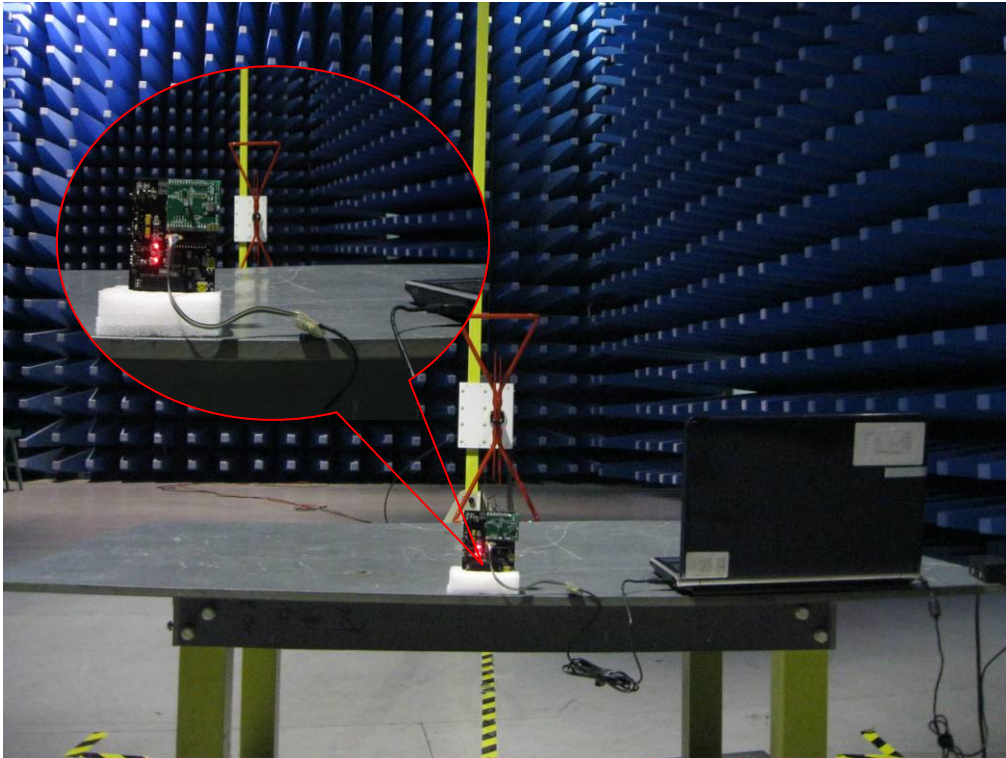

Radiated Emissions Test Setup Below 1GHz - Rear View

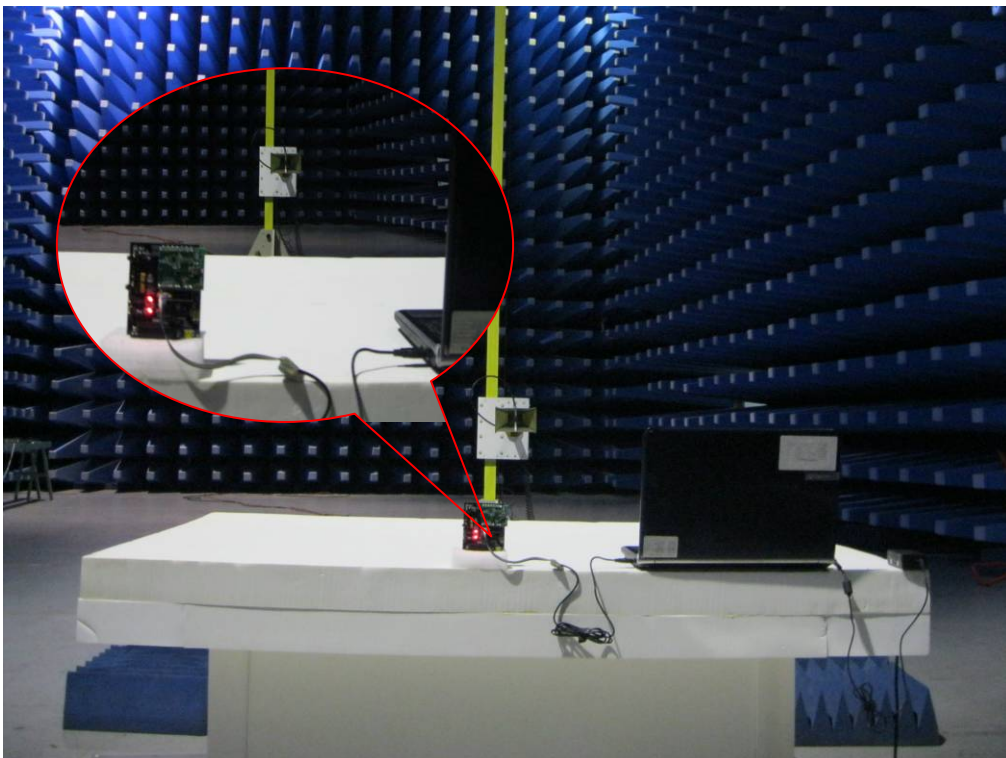

Radiated Emissions Test Setup Above 1GHz - Front View

Annex C. TEST SETUP AND SUPPORTING EQUIPMENT

EUT TEST CONDITIONS

Annex C. i. SUPPORTING EQUIPMENT DESCRIPTION

The following is a description of supporting equipment and details of cables used with the EUT.

Equipment Description (Including Brand Name)	Model & Serial Number	Cable Description (List Length, Type & Purpose)
Gateway Laptop	MS2288 & LXWHF02013951C3CA92200	N/A

Block Configuration Diagram for Conducted Emissions

Note: Before Testing, the EUT must be set up for transmitting by laptop.

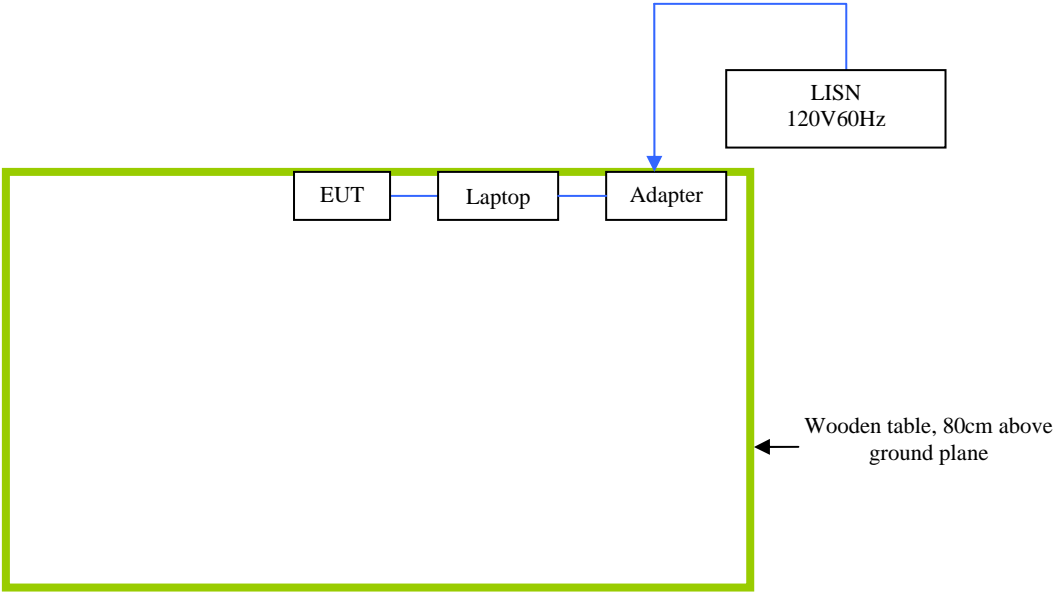

Block Configuration Diagram for Radiated Emissions

Note: Before Testing, the EUT must be set up for transmitting by laptop.

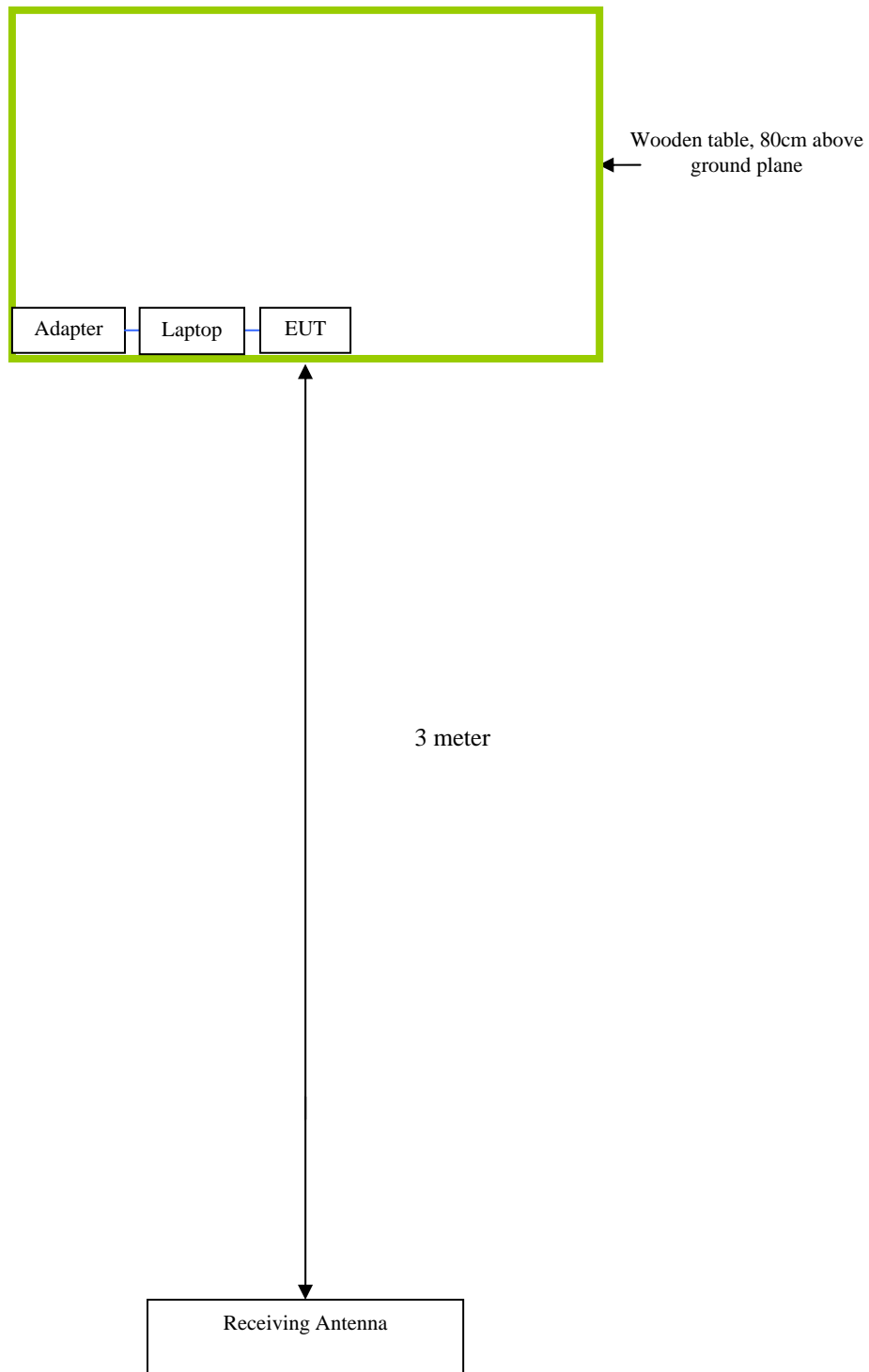

Annex C.ii. EUT OPERATING CONDITIONS

The following is the description of how the EUT is exercised during testing.

Test	Description Of Operation
Emissions Testing	The EUT was continuously transmitting to stimulate the worst case.

Annex D. USER MANUAL / BLOCK DIAGRAM / SCHEMATICS / PART LIST

Please see attachment



SIEMIC, INC.

Accessing global markets

Title: RF Test Report for WiFi and BT combo module
Main Model: FLC-CBM202
Serial Model: See P5
To: FCC Part 15.247: 2012, ANSI C63.4: 2009

Report No.: 12021036-FCC-R3
Issue Date: January 24, 2013
Page: 44 of 46
www.siemic.com.cn

Annex E. DECLARATION OF SIMILARITY



FLAIRCOMM

福建慧翰微电子有限公司

Fujian Flaircomm Microelectronics, Inc.

Declaration letter

To: SIEMIC Nanjing China Laboratories
NO.2-1 Longcang Dadao, Yuhua Economic
Development Zone, Nanjing, China

Dear Sir,

For our business development and marketing requirement, we would like to list different models numbers on the FCC\CE certificates and reports, as following:

Model No.: FLC-CBM202;
 FLC- CBM202IL2A;
 FLC- CBM202VL2A;
 FLC- CBM202CL2A;

The difference between the four models FLC- CBM202、 FLC- CBM202IL2A、 FLC- CBM202VL2A、 FLC- CBM202CL2A is as follows:
FLC- CBM202 is the main model.

1. FLC- CBM202IL2A is similar to FLC- CBM202. The only difference between them is the model names.
2. FLC- CBM202VL2A and FLC- CBM202CL2A are similar to FLC- CBM202. The only difference between them is the product grade.

Like all the other.

Thank you!

Signature:

Printed name/title: Marvin Zhao/President

Fujian Flaircomm Microelectronics, Inc.
Address: 7F, Guomai Building, 116 East JiangBin Ave., Fuzhou, Fujian, P.R.China, 350015
<http://www.flairmicro.com>



SIEMIC, Inc.

Accessing global markets

Title: RF Test Report for WiFi and BT combo module
Main Model: FLC-CBM202
Serial Model: See P5
To: FCC Part 15.247: 2012, ANSI C63.4: 2009

Report No.: 12021036-FCC-R3
Issue Date: January 24, 2013
Page: 45 of 46
www.siemic.com.cn



福建慧翰微电子有限公司

Fujian Flaircomm Microelectronics, Inc.

Ordering information

FLC-CBM202CL2A

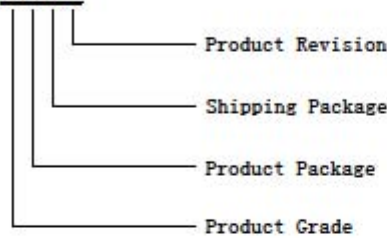

Ordering Information

Note: Because the name "FLC-CBM202IL2A" is not easy to remember, we take "FLC-CBM202" for short as the main model of the product.

1、 Product Revision

Product Revision	Description	Availability
A	Release A	Yes

Product Revision

2、 Shipping Package

Shipping Package	Description	Quantity	Availability
0	Foam Tray	—	No
1	Plastic Tray	—	No
2	Tape	TBD	Yes

Shipping Package

3、 Product Package

Product Package	Description	Availability
Q	QFN	No
L	LGA	Yes
B	BGA	No
C	Connector	No

Product Package

Fujian Flaircomm Microelectronics, Inc.

Address:7F, Guomai Building,116 East JiangBin Ave., Fuzhou, Fujian,P.R.China, 350015

<http://www.flairmicro.com>



SIEMIC, INC.

Accessing global markets

Title: RF Test Report for WiFi and BT combo module
Main Model: FLC-CBM202
Serial Model: See P5
To: FCC Part 15.247: 2012, ANSI C63.4: 2009

Report No.: 12021036-FCC-R3
Issue Date: January 24, 2013
Page: 46 of 46
www.siemic.com.cn



FLAIRCOMM

福建慧翰微电子有限公司

Fujian Flaircomm Microelectronics, Inc.

4. Product Grade

Product Grade	Description	Availability
C	Consumer	Yes
I	Industrial	Yes
V	Automobile After-Market	Yes
A	Automobile Before-Market	No

Product Grade

Note:

- A、 Consumer Grade (C) : Operation temperature range from -20℃ to 70℃. Products can be used as common consumer electronics.
- B、 Industrial Grade (I) : Operation temperature range from -40℃ to 85℃. Product can be used for industrial applications.
- C、 Automobile After-Market Grade (V) : Operation temperature range from -20℃ to 70℃. Product can be used for after-market applications.

Fujian Flaircomm Microelectronics, Inc.

Address:7F, Guomai Building,116 East JiangBin Ave., Fuzhou, Fujian,P.R.China, 350015

<http://www.flairmicro.com>