

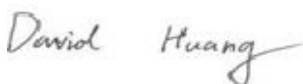

# HAC RF EMISSION TEST REPORT



Report No.: 16070898-HAC-RF

Supersede Report No.: NONE

|   |   |   |
|---|---|---|
| Applicant   | Unimax Communications   |   |
| Product Name  | Mobile Phone  |   |
| Model No.   | MXG-408   |   |
| Standards   | FCC 47 CFR 20.19, ANSI C63.19:2011  |   |
| Test Date   | August 5, 2016  |   |
| Issue Date  | August 17, 2016   |   |
| HAC RF Emission Test Result   | E-Field(dBv/m)  | M Rating  |
|   | 34.03dBv/m  | M4  |
| Test Result   | PASS  |   |
| Equipment complied with the specification   | <input checked="" type="checkbox"/>   |   |
| Equipment did not comply with the specification   | <input type="checkbox"/>  |   |
|    |  |  |
| Wiky Jam<br>Test Engineer   | David Huang<br>Checked By   |   |
| <p>This test report may be reproduced in full only</p> <p>Test result presented in this test report is applicable to the tested sample only</p> |   |   |

Issued by:

**SIEMIC (SHENZHEN-CHINA) LABORATORIES**

Zone A, Floor 1, Building 2 Wan Ye Long Technology Park

South Side of Zhoushi Road, Bao'an District, Shenzhen, Guangdong China 518108

Phone: +86 0755 2601 4629801 Email: [China@siemic.com.cn](mailto:China@siemic.com.cn)

## Laboratory Introduction

SIEMIC, headquartered in the heart of Silicon Valley, with superior facilities in US and Asia, is one of the leading independent testing and certification facilities providing customers with one-stop shop services for Compliance Testing and Global Certifications.



In addition to [testing](#) and [certification](#), SIEMIC provides initial design reviews and [compliance management](#) through out a project. Our extensive experience with [China](#), [Asia Pacific](#), [North America](#), [European, and international](#) compliance requirements, assures the fastest, most cost effective way to attain regulatory compliance for the [global markets](#).

### Accreditations for Conformity Assessment

| Country/Region | Scope                              |
|----------------|------------------------------------|
| USA            | EMC, RF/Wireless, SAR, Telecom     |
| Canada         | EMC, RF/Wireless, SAR, Telecom     |
| Taiwan         | EMC, RF, Telecom, SAR, Safety      |
| Hong Kong      | RF/Wireless, SAR, Telecom          |
| Australia      | EMC, RF, Telecom, SAR, Safety      |
| Korea          | EMI, EMS, RF, SAR, Telecom, Safety |
| Japan          | EMI, RF/Wireless, SAR, Telecom     |
| Singapore      | EMC, RF, SAR, Telecom              |
| Europe         | EMC, RF, SAR, Telecom, Safety      |

|             |                 |
|-------------|-----------------|
| Test Report | 16070898-HAC-RF |
| Page        | 3 of 48         |

---

This page has been left blank intentionally.

**CONTENTS**

|    |   |    |
|----|---|----|
| 1  | TECHNICAL DETAILS .....                             | 5  |
| 2  | TEST CONDITION .....                                | 6  |
| 3  | HAC RF EMISSIONS TEST SYSTEM .....                  | 7  |
| 4  | MODULATION INTERFERENCE FACTOR (MIF).....           | 9  |
| 5  | HAC RF EMISSION TEST PROCEDURE.....                 | 11 |
| 6  | SYSTEM VALIDATION.....                              | 13 |
| 7  | LIST OF EQUIPMENTS .....                            | 14 |
| 8  | HAC RF EMISSIONS MEASUREMENT UNCERTAINTY .....      | 15 |
| 9  | RF CONDUCTED POWER & TESTED MODE JUSTIFICATION..... | 16 |
| 10 | HAC RF EMISSIONS TEST RESULTS .....                 | 16 |
|    | ANNEX A SYSTEM CHECK .....                          | 18 |
|    | ANNEX B TEST PLOTS .....                            | 20 |
|    | ANNEX C TEST SETUP PHOTO.....                       | 24 |
|    | ANNEX D CALIBRATION REPORT .....                    | 25 |

# 1 TECHNICAL DETAILS

|  |   |
|--|---|
| <b>Purpose</b>                         | <b>Compliance testing of Mobile Phone model MXG-408 with stipulated standard</b>  |
| <b>Applicant / Client</b>              | <b>Unimax Communications<br/>18201 McDermott Street West Suite E Irvine, CA 92614</b>   |
| <b>Manufacturer</b>                    | <b>Unimax Communications LLC<br/>18201 McDermott Street West Suite E Irvine, CA 92614</b>   |
| <b>Laboratory performing the tests</b> | <b>SIEMIC(Shenzhen-China) Laboratories<br/>Zone A, Floor 1, Building 2, Wan Ye Long Technology Park, South Side of<br/>Zhoushi Road, Bao'an District, Shenzhen 518108, Guangdong, P.R.C.<br/>Tel: +(86) 0755-26014629<br/>VIP Line: 950-4038-0435</b>   |
| <b>Test report reference number</b>    | <b>16070898-HAC-RF</b>  |
| <b>Date EUT received</b>               | <b>July 27,2016</b>   |
| <b>Standard applied</b>                | <b>CFR 20.19 , ANSI C63.19:2011</b>   |
| <b>Dates of test (from – to)</b>       | <b>August 5, 2016</b>   |
| <b>No of Units:</b>                    | <b>1</b>  |
| <b>Equipment Category:</b>             | <b>PCE</b>  |
| <b>Trade Name:</b>                     | <b>Unimax Communications</b>  |
| <b>Model Name:</b>                     | <b>MXG-408</b>  |
| <b>RF Operating Frequency (ies)</b>    | <b>GSM850 TX : 824.2 ~ 848.8 MHz; RX : 869.2 ~ 893.8 MHz<br/>PCS1900 TX : 1850.2 ~ 1909.8 MHz; RX : 1930.2 ~ 1989.8 MHz<br/>UMTS-FDD Band V TX : 826.4 ~ 846.6 MHz; RX : 871.4 ~ 891.6 MHz<br/>UMTS-FDD Band II TX :1852.4 ~ 1907.6 MHz; RX : 1932.4 ~ 1987.6 MHz<br/>BT &amp; BLE:2402~ 2480MHz(TX/RX)<br/>WIFI:802.11b/g/n(20M): 2412-2462 MHz(TX/RX)<br/>GPS Rx:1575.42MHz</b> |
| <b>Antenna Type:</b>                   | <b>PIFA Antenna</b>   |
| <b>Modulation:</b>                     | <b>GSM / GPRS : GMSK<br/>EGPRS: GMSK,8PSK<br/>WCDMA:QPSK<br/>Wifi: DSSS, OFDM<br/>Bluetooth: GFSK, <math>\pi</math> /4-DQPSK, 8DPSK<br/>BLE:GFSK<br/>GPS:BPSK</b>   |
| <b>FCC ID:</b>                         | <b>P46-UMX40INT</b>   |

## 2 Test Condition

### Ambient Condition

Temperature: 20 °C ~ 24 °C

Humidity : < 60 %

### Testing Configuration

The device was controlled by using a base station emulator R&S CMU200. Communication between the device and the emulator was established by air link. The power control bits was set to "Always Up" from the emulator to radiate maximum output power during all testing

Measurements were performed on the low, middle and high channels of all bands

### List of Air Interfaces/Bands & Operating Modes

| Air-Interface | Band (MHz)              | Type | C63.19/ Tested | Simultaneous Transmissions<br>Note: Not to be test | Concurred single transmission | Reduced power 20.19(c)(1) | Voice Over Digital Transport (Data) |
|---------------|-------------------------|------|----------------|--|-------------------------------|---------------------------|-------------------------------------|
| GSM           | 850                     | VO   | YES            | Yes, with Bluetooth/wifi                           | NA                            | NA                        | NA                                  |
|               | 1900                    |      |                |  |                               | NA                        | NA                                  |
|               | GPRS/EDGE               | DT   | No             | NA   | NA                            | NA                        | NA                                  |
| WCDMA         | Band II ,<br>Band V R99 | VO   | Yes            | Yes, with Bluetooth/wifi                           | NA                            | NA                        | NA                                  |
|               | HSDPA                   | DT   | NO             | NA   | NA                            | NA                        | NA                                  |
| WIFI          | 2.4G                    | DT   | NO             | Yes, with WWAN                                     | NA                            | NA                        | Yes                                 |
| BT            | 2.4G                    | DT   | NO             | Yes, with WWAN                                     | NA                            | NA                        | NA                                  |

VO Voice CMRS/PTSN Service Only  
V/D Voice CMRS/PSTN and Data Service  
DT Digital Transport

Note: \* HAC Rating was not base on concurrent voice and data modes, Noncurrent mode was found to represent worst Case rating.

### 3 HAC RF Emissions Test System

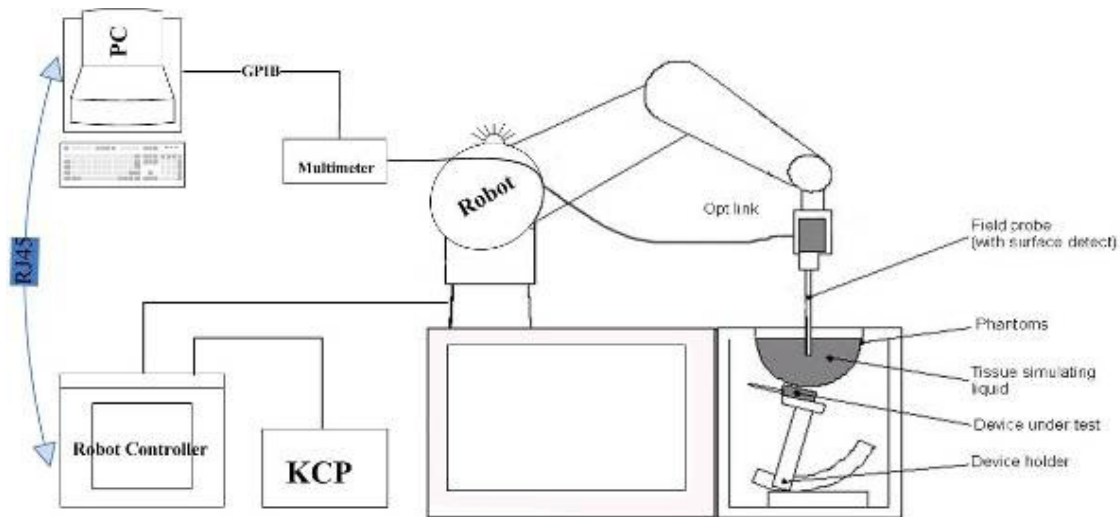

These measurements were performed with the automated near-field scanning system OPENSAR from SATIMO. The system is based on a high precision robot (working range: 850 mm), which positions the probes with a positional repeatability of better than  $\pm 0.02$  mm. Special E- and H-field probes have been developed for measurements close to material discontinuity, the sensors of which are directly loaded with a Schottky diode and connected via highly resistive lines to the data acquisition unit.

**The OPENSAR system for performing compliance tests consist of the following items:**

1. A standard high precision 6-axis robot (KUKA) with controller and software.
2. KUKA Control Panel (KCP).
3. A dosimetric probe, i.e., an isotropic E-field probe optimized and calibrated for usage in tissue simulating liquid. The probe is equipped with an optical surface detector system.
4. The functions of the PC plug-in card are to perform the time critical task such as signal filtering, surveillance of the robot operation fast movement interrupts.
5. A computer operating Windows XP.
6. OPENSAR software.
7. Remote control with teaches pendant and additional circuitry for robot safety such as warning lamps, etc.
8. The SAM phantom enabling testing left-hand right-hand and body usage.
9. The Position device for handheld EUT.
10. Tissue simulating liquid mixed according to the given recipes (see Application Note).
11. System validation dipoles to validate the proper functioning of the system.

## COMOHAC E-Field Probe

The probe could be checked by measuring the resistance of the three dipoles  
 Probe calibration is realized by using the waveguide method as described in the IEEE 1309-2005 standard.



|   |   |
|---|---|
| Frequency Range                                   | 100 MHz - 3 GHz   |
| Probe length                                      | 330 mm  |
| Length of one dipole                              | 3.3 mm  |
| Maximum external diameter                         | 8 mm  |
| Probe extremity diameter                          | 6 mm  |
| Distance between dipoles/probe extremity          | 3.5 mm  |
| Resistance of the three dipole (at the connector) | Dipole 1: R1=1.337 MΩ<br>Dipole 2: R2=1.125 MΩ<br>Dipole 3: R3=1.338 MΩ |
| Diode Compression Point                           | Dipole 1: DCP1=129 mV<br>Dipole 2: DCP2=128 mV<br>Dipole 3: DCP3=129 mV |

HAC field measurements take place in the close near field with high gradients. Increasing the measuring distance from the source will generally decrease the measured field values (in case of the validation dipole approx. 10% per mm).

Magnetic field sensors are measuring the integral of the H-field across their sensor area surrounded by the loop. They are calibrated in a precise, homogeneous field. When measuring a gradient field, the result will be very close to the field in the center of the loop which is equivalent to the value of a homogeneous field equivalent to the center value. But it will be different from the field at the field at the border of the loop.

Consequently, two sensors with different loop diameters – both calibrated ideally – would give different results when measuring from the edge of the probe sensor elements. The behavior for electrically small E-field sensors is equivalent. See below for distance plots from a WD which show the conservative nature of field readings at the probe element center vs. measurements at the sensor end:

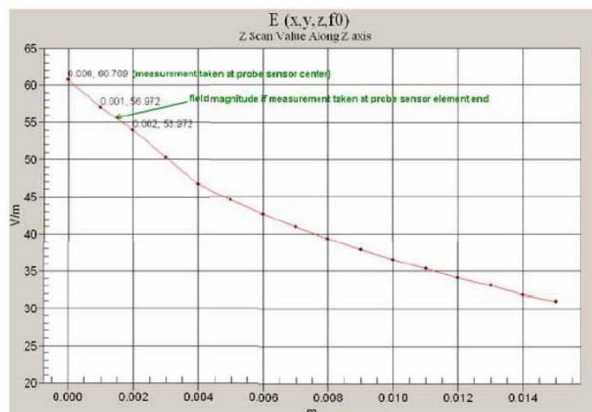

**Z-Axis Scan at maximum point above a typical wireless device for E-field**



## 4 Modulation Interference Factor (MIF)

The HAC Standard ANSI C63.19-2011 defines a new scaling using the Modulation Interference Factor (MIF) which replaces the need for the Articulation Weighting Factor (AWF) during the evaluation and is applicable to any modulation scheme.

The Modulation Interference factor (MIF, in dB) is added to the measured average E-field (in dBV/m) and converts it to the RF Audio Interference level (in dBV/m). This level considers the audible amplitude modulation components in the RF E-field. CW fields without amplitude modulation are assumed to not interfere with the hearing aid electronics. Modulations without time slots and low fluctuations at low frequencies have low MIF values, TDMA modulations with narrow transmission and repetition rates of few 100 Hz have high MIF values and give similar classifications as ANSI C63-2007.

### Definitions

COMHAC E-field probes have a bandwidth <10 kHz and can therefore not evaluate the RF envelope in the full audio band. OPENHAC is therefore using the "indirect" measurement method according to ANSI C63.19-2011 which is the primary method. These near field probes read the averaged E-field measurement.

Especially for the new high peak-to-average (PAR) signal types, the probes shall be linearized by probe modulation response (PMR) calibration in order to not overestimate the field reading.

The evaluation method or the MIF is defined in ANSI C63.19-2011 section D.7. An RMS demodulated RF signal is fed to a spectral filter (similar to an A weighting filter) and forwarded to a temporal filter acting as a quasi-peak detector. The averaged output of these filtering is called to a 1 kHz 80% AM signal as reference. MIF measurement requires additional instrumentation and is not well suited for evaluation by the end user with reasonable uncertainty

It may alternatively be determined through analysis and simulation, because it is constraint and characteristic for a communication signal. OPENHAC uses well defined signals for PMR calibration. The MIF of these signals has been determined by simulation and is automatically applied.

MIF values were not tested by a probe or as specified in the standards but are based on analysis provided by SATIMO for all the air interfaces (GSM, WCDMA, CDMA). For GSM, CDMA2000, WCDMA, the data included in this report are for the worst case operating modes.

| Communication System Name       |        |
|---------------------------------|--------|
| UMTS-FDD(WCDMA)                 | -20.00 |
| GSM-FDD(TDMA,GMSK)              | +3.50  |
| CDMA2000(1XRTT, RC3)            | -19.00 |
| CDMA2000(RC1;1/8th frame rate); | +3.3   |

A PMR calibrated probe is linearized for the selected waveform over the full dynamic range within the uncertainty specified in its calibration certificate. COMHAC E-field probes have a bandwidth <10 kHz and can therefore not evaluate the RF envelope in the full audio band. OPENHAC is therefore using the "indirect" measurement method according to ANSI C63.19-2011 which is the primary method. These near field probes read the averaged E-field measurement. Especially for the new high peak-to-average (PAR) signal types, the probes shall be linearized by PMR calibration in order to not overestimate the field reading.

The evaluation method for the MIF is defined in ANSI C63.19-2011 section D.7. An RMS demodulated RF

|             |                 |
|-------------|-----------------|
| Test Report | 16070898-HAC-RF |
| Page        | 10 of 48        |

signal is fed to a spectral filter (similar to an A weighting filter) and forwarded to a temporal filter acting as a quasi-peak detector. The averaged output of these filtering is scaled to a 1 kHz 80% AM signal as reference. MIF measurement requires additional instrumentation and is not well suited for evaluation by the end user with reasonable uncertainty. It may alternatively be determined through analysis and simulation, because it is constant and characteristic for a communication signal. OPENHAC uses well-defined signals for PMR calibration. The MIF of these signals has been determined by simulation and is automatically applied. The MIF measurement uncertainty is estimated as follows, for modulation frequencies from slotted waveforms with fundamental frequency and at least 2 harmonics within 10 kHz:

- 0.2 dB for MIF -7 to +5 dB,*
- 0.5 dB for MIF -13 to +11 dB*
- 1 dB for MIF > -20 dB*

The modulation interference factors obtained were applied to readings taken of the actual wireless device in order to obtain an accurate audio interference level reading using the formula:

$$\text{Audio Interference Level [dB(V/m)]} = 20 * \log[\text{Raw Field Value (V/m)}] + \text{MIF (dB)}$$

## 5 HAC RF Emission Test Procedure

The following are step-by-step test procedures.

- a) Confirm proper operation of the field probe, probe measurement system and other instrumentation and the positioning system.
- b) Position the WD in its intended test position.
- c) Set the WD to transmit a fixed and repeatable combination of signal power and modulation characteristic that is representative of the worst case (highest interference potential) encountered in normal use. Transiently occurring start-up, changeover, or termination conditions, or other operations likely to occur less than 1% of the time during normal operation, may be excluded from consideration.
- d) The center sub-grid shall be centered on the T-Coil mode perpendicular measurement point or the acoustic output, as appropriate. Locate the field probe at the initial test position in the 50 mm by 50 mm grid, which is contained in the measurement plane, refer to illustrated in Figure 1. If the field alignment method is used, align the probe for maximum field reception.
- e) Record the reading at the output of the measurement system
- f) Scan the entire 50 mm by 50 mm region in equally spaced increments and record the reading at each measurement point. The distance between measurement points shall be sufficient to assure the identification of the maximum reading.
- g) Identify the five contiguous sub-grids around the center sub-grid whose maximum reading is the lowest of all available choices. This eliminates the three sub-grids with the maximum readings. Thus, the six areas to be used to determine the WD's highest emissions are identified.
- h) Identify the maximum reading within the non-excluded sub-grids identified in step g).
- i) Convert the highest field reading within identified in step h) to RF audio interference level, in V/m, by taking the square root of the reading and then dividing it by the measurement system transfer function, established in 5.5.1.1 Convert this result to dB(V/m) by taking the base-10 logarithm and multiplying by 20. Indirect measurement method Replacing step i), the RF audio interference level in dB (V/m) is obtained by adding the MIF (in dB) to the maximum steady-state rms field-strength reading, in dB(V/m), from step h). Use this result to determine the category rating
- j) Compare this RF audio interference level with the categories in Clause 8 (ANSI C63.19-2011) and record the resulting WD category rating
- k) For the T-Coil mode M-rating assessment, determine whether the chosen perpendicular measurement point is contained in an included sub-grid of the first scan. If so, then a second scan is not necessary. The first scan and resultant category rating may be used for the T-Coil mode M rating. Otherwise, repeat step a) through step i), with the grid shifted so that it is centered on the perpendicular measurement point. Record the WD category rating.



**Test flowchart Per ANSI-PC63.19 2011**

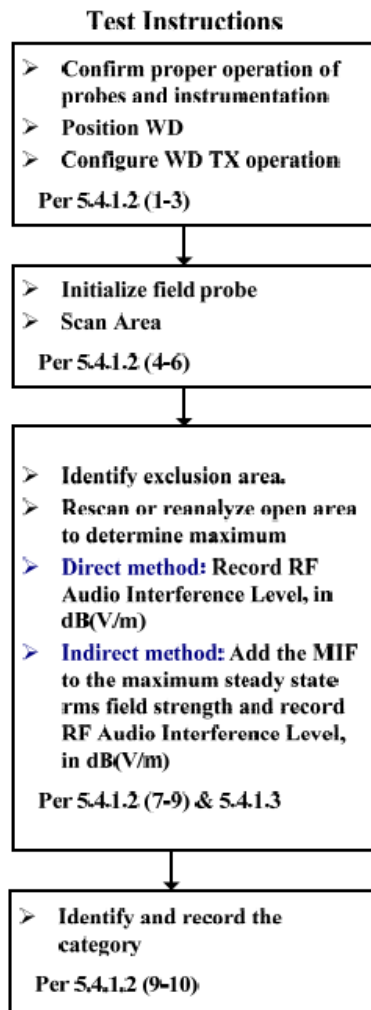

Figure 5.3—WD near-field emission scan flowchart

## 6 System Validation

The test setup was validated when first configured and verified periodically thereafter to ensure proper function. The procedure provided in this section is a validation procedure using dipole antennas for which the field levels were computed by numeric modeling.

### Procedure

Place a dipole antenna meeting the requirements given in ANSI C63.19-2011 in the normally occupied by the WD. The dipole antenna serves as a known source for an electrical and magnetic output. Position the E-field probe so that the following occurs:

- The probes and their cables are parallel to the coaxial feed of the dipole antenna
- The probe cables and the coaxial feed of the dipole antenna approach the measurement area from opposite directions
- The center point of the probe element(s) is 15 mm from the closest surface of the dipole elements.

Scan the length of the dipole with the E-field probe and record the two maximum values found near the dipole ends. Average the two readings and compare the reading to the expected value in the calibration certificate or the expected value in this standard.

Setup diagram

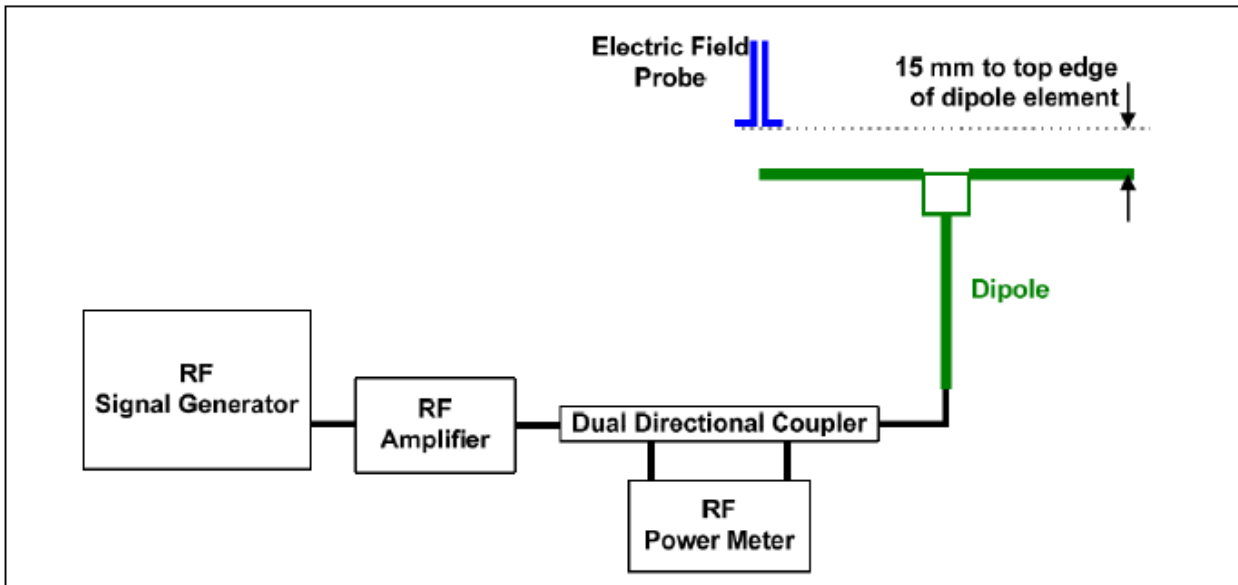

### 5.1 System Validation Results

| Calibration Dipole | F(MHz) | Input Power (mW) | Measured Results | E-field Target Values (V/m) (From MVG) | Deviation1) (%) |
|--------------------|--------|------------------|------------------|--|-----------------|
| DHA31              | 835    | 100              | 226.16           | 220.4                                  | 2.61            |
| DHA32              | 1880   | 100              | 158.28           | 153.4                                  | 3.18            |

Note: performed at 8/5/2016

## 7 List of Equipments

| Name of Equipment                                | Manufacturer             | Type/Model                                  | Serial Number   | Calibration Due |
|--|--------------------------|---|-----------------|-----------------|
| P C  | Compaq                   | PV 3.06GHz                                  | 375052-AA1      | N/A             |
| Signal Generator                                 | Agilent                  | 8665B-008                                   | 3744A01304      | 05/17/2017      |
| MultiMeter                                       | Keithley                 | MiltiMeter 2000                             | 1259033         | 08/13/2016      |
| S-Parameter Network Analyzer                     | Agilent                  | 8753ES                                      | US38161019      | 08/04/2017      |
| Wireless Communication Test Set                  | R & S                    | CMU200                                      | 111078          | 07/22/2017      |
| Power Meter                                      | HP                       | 437B  | 3038A03648      | 05/17/2017      |
| COMOHAC E-Field Probe                            | MVG                      | SCE   | SN 31/10 EPH22  | 10/21/2016      |
| Communication Antenna                            | SATIMO                   | ANTA30                                      | SN 31/10 ANTA30 | N/A             |
| Mobile Phone POSITIONING DEVICE                  | SATIMO                   | MSH63                                       | SN 31/10 MSH63  | N/A             |
| COMOHAC Broadband Dipole 800-950                 | SATIMO                   | COMOHAC<br>Broadband Dipole<br>800-950MHz   | SN 24/11 DHA31  | 10/28/2016      |
| COMOHAC Broadband Dipole 1700-2000               | SATIMO                   | COMOHAC<br>Broadband Dipole<br>1700-2000MHz | SN 24/11 DHB32  | 10/28/2016      |
| PHANTOM TABLE                                    | SATIMO                   | N/A   | N/A             | N/A             |
| 6 AXIS ROBOT                                     | KUKA                     | KR5   | 949319          | N/A             |
| High Power Solid State Amplifier (80MHz~1000MHz) | Instruments for Industry | CMC150                                      | M631-0408       | N/A             |
| Medium Power Solid State Amplifier (0.8~4.2GHz)  | Instruments for Industry | S41-25                                      | M629-0408       | N/A             |
| Wave Tube Amplifier 4-8 GHz at 20Watt            | Hughes Aircraft Company  | 1277H02F000                                 | 81              | N/A             |

## 8 HAC RF Emissions Measurement Uncertainty

| Uncertainty Component                                      | Tolerances (dB) / % | Probability Distribution | Divisor    | Ci   | Uncertainty (dB) | Uncertainty (%) |
|--|---------------------|--------------------------|------------|------|------------------|-----------------|
| <b>Measurement System Related</b>                          |                     |                          |            |      |                  |                 |
| RF Reflections   | 0.1 dB              | R                        | $\sqrt{3}$ | 1    | 0.06             | N/A             |
| Field Probe Conv. Factor                                   | 0.2 dB              | R                        | $\sqrt{3}$ | 1    | 0.12             | N/A             |
| Field Probe Anisotropy                                     | 0.25 dB             | R                        | $\sqrt{3}$ | 1    | 0.14             | N/A             |
| Positioning Accuracy                                       | 0.1 dB              | R                        | $\sqrt{3}$ | 1    | 0.06             | N/A             |
| Probe Cable Placement                                      | 0.1 dB              | R                        | $\sqrt{3}$ | 1    | 0.06             | N/A             |
| System Repeatability                                       | 0.2 dB              | R                        | $\sqrt{3}$ | 1    | 0.12             | N/A             |
| EUT Repeatability  | 0.1 dB              | N                        | 1          | 1    | 0.10             | N/A             |
| <i>Combined Standard Uncertainty :</i>                     |                     |                          |            |      | 0.26             | 6.36 %          |
| <b>Test Sample Related</b>                                 |                     |                          |            |      |                  |                 |
| Device Positioning Vertical                                | 4.7 %               | R                        | $\sqrt{3}$ | 0.67 | N/A              | 1.8 %           |
| Device Positioning Lateral                                 | 1.0 %               | R                        | $\sqrt{3}$ | 1    | N/A              | 0.6 %           |
| Device Holder  | 2.4 %               | R                        | $\sqrt{3}$ | 1    | N/A              | 1.4 %           |
| Test Sample  | 0.3 %               | N                        | 1          | 1    | N/A              | 0.3 %           |
| Power drift  | 5 %                 | R                        | $\sqrt{3}$ | 1    | N/A              | 1.7 %           |
| <b>PMF Calculation</b>                                     |                     |                          |            |      |                  |                 |
| Power Sensor   | 1.0 %               | R                        | $\sqrt{3}$ | 1    | N/A              | 0.6 %           |
| Dual Directional Coupler                                   | 1.0 %               | R                        | $\sqrt{3}$ | 1    | N/A              | 0.6 %           |
| <b>Phantom and setup Related</b>                           |                     |                          |            |      |                  |                 |
| Phantom Thickness  | 2.4 %               | R                        | $\sqrt{3}$ | 0.67 | N/A              | 0.9 %           |
| <b>Combined Standard Uncertainty</b>                       |                     |                          |            |      | 7.1 %            |                 |
| <b>Expanded Standard Uncertainty (K=2, confidence 95%)</b> |                     |                          |            |      | 14.2 %           |                 |

## 10 HAC RF Emissions Test Results

### RF Conducted power

Mobile phone radio output power measurement

1. The transmitter output port was connected to base station emulator.
2. Establish communication link between emulator and EUT and set EUT to operate at maximum output power all the time.
3. Select lowest, middle, and highest channels for each band and different possible test mode.
4. Measure the conducted peak burst power and conducted average burst power from EUT antenna port.

| Burst Average Power (dBm); |        |       |       |         |       |        |
|----------------------------|--------|-------|-------|---------|-------|--------|
| Band                       | GSM850 |       |       | GSM1900 |       |        |
| Channel                    | 128    | 190   | 251   | 512     | 661   | 810    |
| Frequency (MHz)            | 824.2  | 836.6 | 848.8 | 1850.2  | 1880  | 1909.8 |
| GSM Voice (1 uplink),GMSK  | 32.45  | 32.64 | 32.23 | 30.35   | 30.21 | 30.25  |

### WCDMA BAND V

| Band/ Time Slot configuration | Channel | Frequency | Average power (dBm) |
|-------------------------------|---------|-----------|---------------------|
| ARM VOCIE (R99)               | 4132    | 826.4     | 21.16               |
|                               | 4175    | 835       | 21.23               |
|                               | 4232    | 846.4     | 21.18               |

### WCDMA Band II :

| Band/ Time Slot configuration | Channel | Frequency | Average power (dBm) |
|-------------------------------|---------|-----------|---------------------|
| ARM VOCIE (R99)               | 9262    | 1852.4    | 21.98               |
|                               | 9400    | 1880.0    | 21.94               |
|                               | 9538    | 1907.6    | 21.87               |

### 8.1 RF Emissions Measurement Criteria

WD RF audio interference level categories in logarithmic units

| Emission Categories | E-field emissions |                   |
|---------------------|-------------------|-------------------|
|                     | < 960 MHz         | > 960 MHz         |
| Category M1         | 50 to 55 dB (V/m) | 40 to 45 dB (V/m) |
| Category M2         | 45 to 50 dB (V/m) | 35 to 40 dB (V/m) |
| Category M3         | 40 to 45 dB (V/m) | 30 to 35 dB (V/m) |
| Category M4         | <40 dB (V/m)      | <30 dB (V/m)      |



## 8.2 HAC (RF Emissions) Test Results

| Operating Mode | Channel No. | Frequency(MHz) | Peak E Field (dBv/m) | M rating | Plots |
|----------------|-------------|----------------|----------------------|----------|-------|
| GSM850         | 128         | 824.2          | 33.87                | M4       | -     |
|                | 192         | 836.6          | 34.03                | M4       | 1#    |
|                | 251         | 848.8          | 33.69                | M4       | -     |
| GSM1900        | 512         | 1850.2         | 24.26                | M4       | -     |
|                | 661         | 1880.0         | 24.38                | M4       | 2#    |
|                | 810         | 1909.8         | 24.17                | M4       | -     |
| WCDMA Band V   | 4132        | 826.4          | 33.42                | M4       | -     |
|                | 4175        | 835            | 33.58                | M4       | 3#    |
|                | 4232        | 846.4          | 33.36                | M4       | -     |
| WCDMA Band II  | 9262        | 1852.4         | 26.56                | M4       | -     |
|                | 9400        | 1880.0         | 26.70                | M4       | 4#    |
|                | 9538        | 1907.6         | 26.62                | M4       | -     |

# Annex A System Check

**CW850**  
**Band**  
**Frequency (MHz): 835.000000**  
**Input power: 20dBm**

### Surface HAC

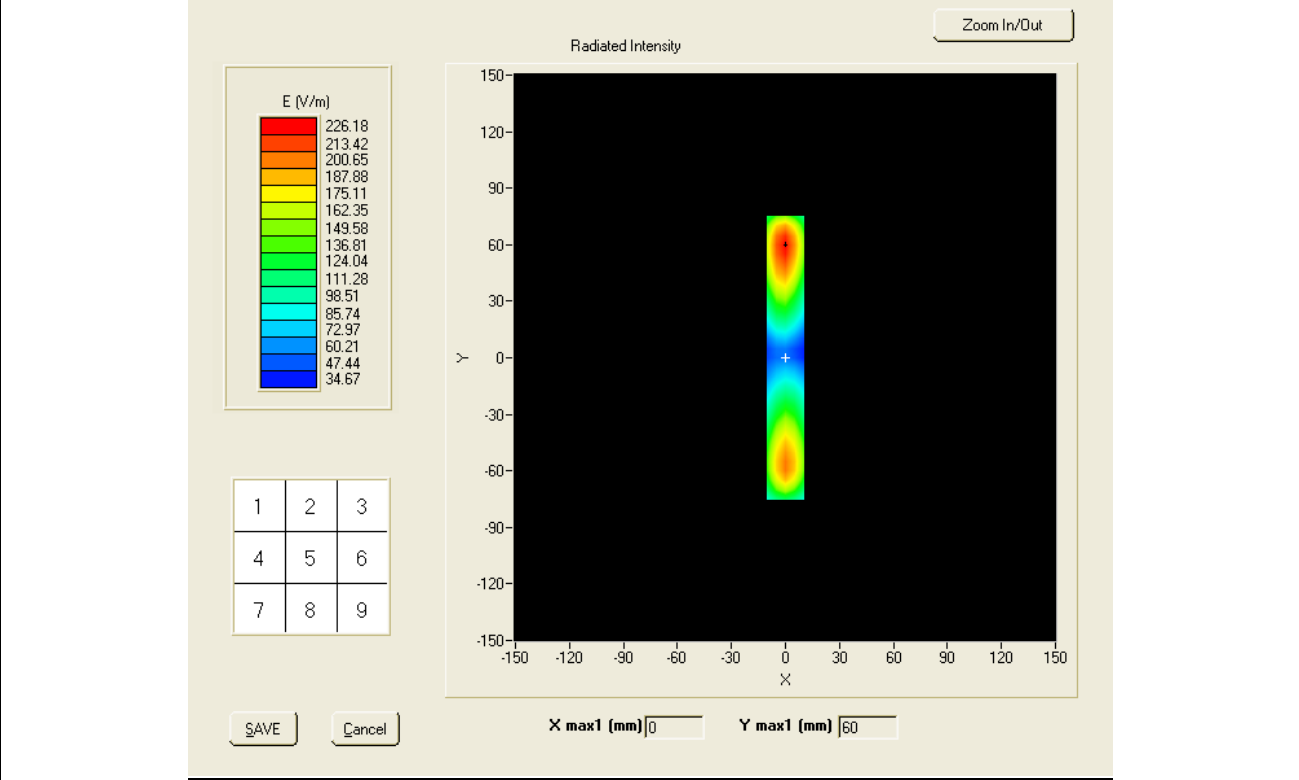

**Probe Modulation Factor = 1.000000**  
**Maximum value of total field = 226.16 V/m**

**CW1900**  
**Band**  
**Frequency (MHz): 1880.00000**  
**Input power: 20dBm**

**Surface HAC**

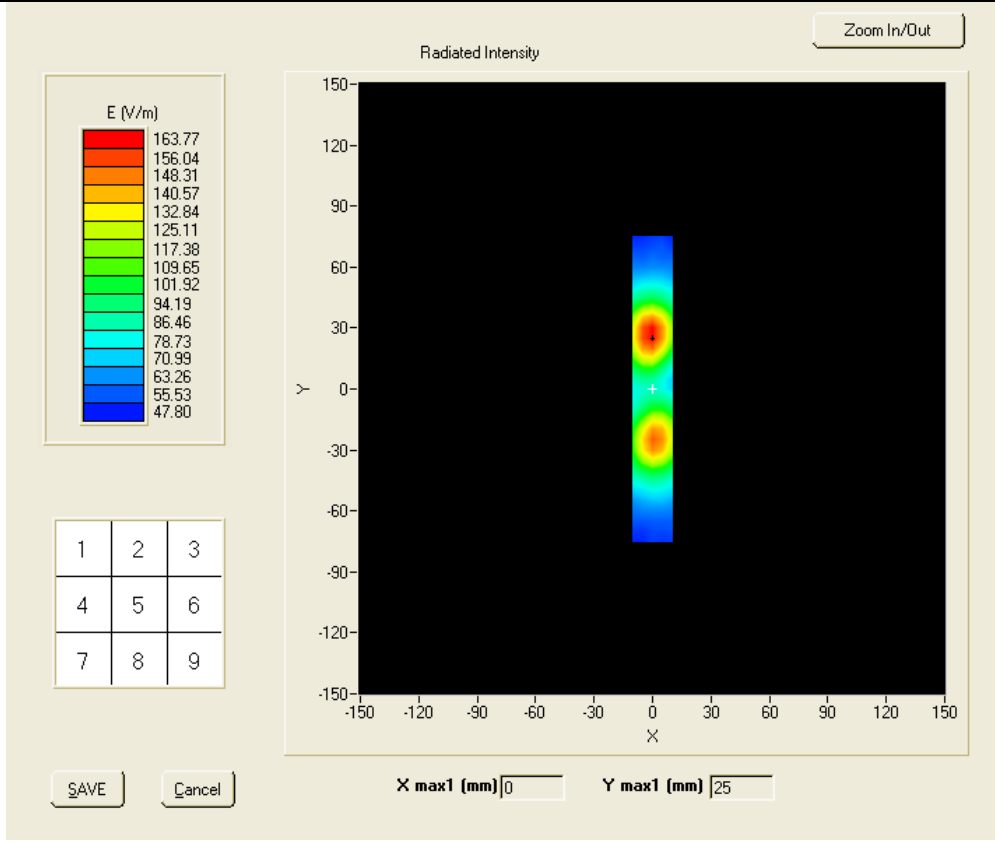

**Probe Modulation Factor = 1.000000**  
**Maximum value of total field = 158.28 V/m**

## Annex B Test plots

|                                 |
|---------------------------------|
| Test Item 1                     |
| GSM850                          |
| Middle Band                     |
| Frequency (MHz): 836.600000     |
| E-Field                         |
| Grid size (mm x mm): 50.0, 50.0 |
| Step (mm): 5                    |

### Surface HAC

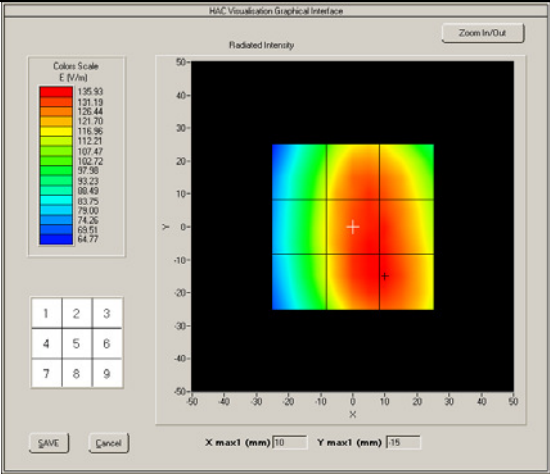

Maximum value of total field =34.03 dB (V/m)  
**Hearing Aid Near-Field Category: M4**

### E in dB (V/m)

|               |                      |                      |
|---------------|----------------------|----------------------|
| Grid 1: 32.64 | Grid 2: 33.82        | Grid 3: 33.64        |
| Grid 4: 32.83 | <b>Grid 5: 34.03</b> | <b>Grid 6: 33.95</b> |
| Grid 7: 32.70 | <b>Grid 8: 34.07</b> | <b>Grid 9: 34.05</b> |

|                                 |
|---------------------------------|
| Test Item 2                     |
| PCS1900                         |
| Middle Band                     |
| Frequency (MHz): 1880.0000      |
| E-Field                         |
| Grid size (mm x mm): 50.0, 50.0 |
| Step (mm): 5                    |

**Surface HAC**

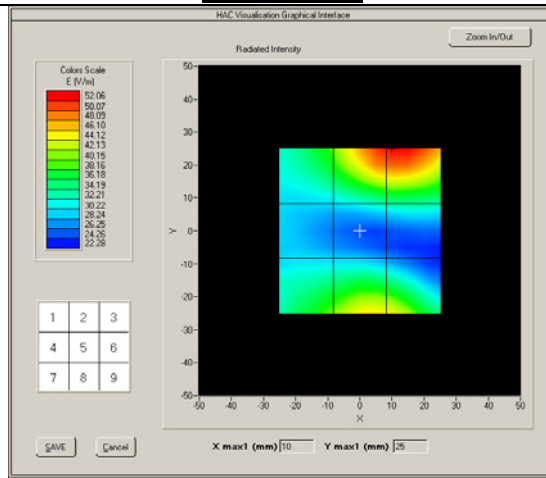

Maximum value of total field = 24.38dB (V/m)  
**Hearing Aid Near-Field Category: M4**

E in dB (V/m)

|                      |                      |                      |
|----------------------|----------------------|----------------------|
| <b>Grid 1: 23.40</b> | <b>Grid 2: 25.67</b> | <b>Grid 3: 25.74</b> |
| Grid 4: 20.75        | Grid 5: 21.91        | Grid 6: 21.99        |
| Grid 7: 23.47        | <b>Grid 8: 24.38</b> | Grid 9: 24.19        |

|                                 |
|---------------------------------|
| Test Item 3                     |
| WCDMA Band V                    |
| Middle Band                     |
| Frequency (MHz): 835.00000      |
| E-Field                         |
| Grid size (mm x mm): 50.0, 50.0 |
| Step (mm): 5                    |

**Surface HAC**

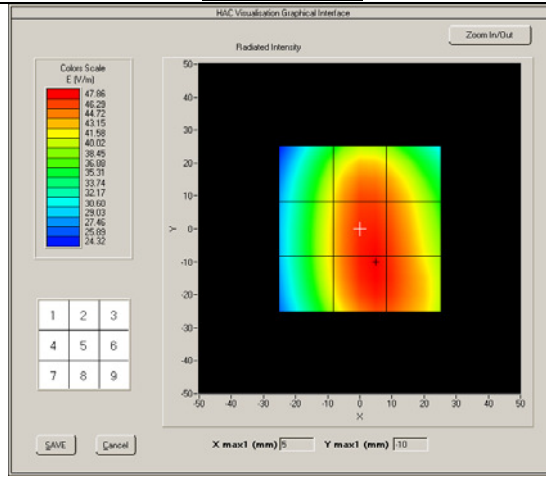

Maximum value of total field = 33.58 dB (V/m)

**Hearing Aid Near-Field Category: M4**

E in dB (V/m)

|               |                      |                      |
|---------------|----------------------|----------------------|
| Grid 1: 32.47 | Grid 2: 33.30        | Grid 3: 32.98        |
| Grid 4: 32.68 | <b>Grid 5: 33.58</b> | <b>Grid 6: 33.34</b> |
| Grid 7: 32.67 | <b>Grid 8: 33.60</b> | <b>Grid 9: 33.41</b> |

Test Item 4  
 WCDMA Band II  
 Middle Band  
 Frequency (MHz): 1880.0000  
 E-Field  
 Grid size (mm x mm): 50.0, 50.0  
 Step (mm): 5

**Surface HAC**

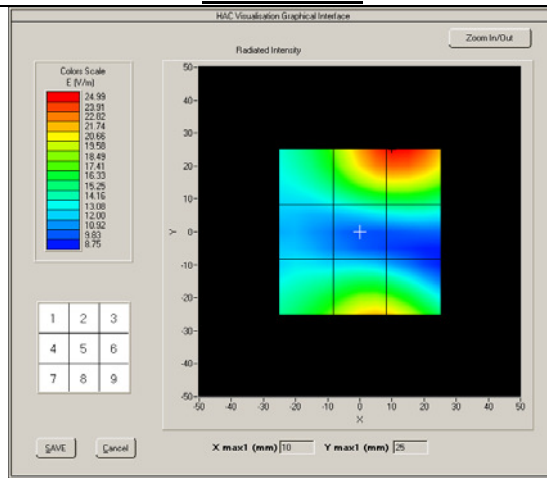

Maximum value of total field = 26.70 dB (V/m)  
**Hearing Aid Near-Field Category: M4**

**E in dB (V/m)**

|                      |                      |                      |
|----------------------|----------------------|----------------------|
| <b>Grid 1: 25.23</b> | <b>Grid 2: 27.91</b> | <b>Grid 3: 27.98</b> |
| Grid 4: 22.40        | Grid 5: 23.88        | Grid 6: 23.96        |
| Grid 7: 25.41        | <b>Grid 8: 26.70</b> | Grid 9: 26.52        |

## Annex C Test Setup Photo





## Annex D Calibration Report



### COMOHAC E-Field Probe Calibration Report

Ref: ACR.179.10.12.SATU.A

#### **SIEMIC TESTING AND CERTIFICATION SERVICES**

ZONE A, FLOOR 1, BUILDING 2, WAN YE LONG  
TECHNOLOGY PARK, SOUTH SIDE OF ZHOUSHI ROAD,  
SHIYAN STREET, BAO'AN DISTRICT, SHENZHEN 518108,  
GUANGDONG, P.R.C.

#### **MVG COMOHAC E-FIELD PROBE**

SERIAL NO.: SN 31/10 EPH22

Calibrated at MVG US  
2105 Barrett Park Dr. - Kennesaw, GA 30144



Calibration Date: 10/21/2015

*Summary:*

This document presents the method and results from an accredited COMOSAR Dosimetric E-Field Probe calibration performed in MVG USA using the CALISAR / CALIBAIR test bench, for use with a COMOSAR system only. All calibration results are traceable to national metrology institutions.

|             |                 |
|-------------|-----------------|
| Test Report | 16070898-HAC-RF |
| Page        | 26 of 48        |



**COMOHAC E-FIELD PROBE CALIBRATION REPORT**

Ref: ACR.179.10.12.SATU.A

|                      | <i>Name</i>   | <i>Function</i> | <i>Date</i> | <i>Signature</i>     |
|----------------------|---------------|-----------------|-------------|----------------------|
| <i>Prepared by :</i> | Jérôme LUC    | Product Manager | 10/21/2015  | <i>JS</i>            |
| <i>Checked by :</i>  | Jérôme LUC    | Product Manager | 10/21/2015  | <i>JS</i>            |
| <i>Approved by :</i> | Kim RUTKOWSKI | Quality Manager | 10/21/2015  | <i>Kim Rutkowski</i> |

|                       |   |
|-----------------------|---|
|                       | <i>Customer Name</i>                      |
| <i>Distribution :</i> | SIEMIC Testing and Certification Services |

| <i>Issue</i> | <i>Date</i> | <i>Modifications</i> |
|--------------|-------------|----------------------|
| A            | 10/21/2015  | Initial release      |
|              |             |                      |
|              |             |                      |



**TABLE OF CONTENTS**

1 Device Under Test ..... 4

2 Product Description ..... 4

    2.1 General Information ..... 4

3 Measurement Method ..... 4

    3.1 Linearity ..... 4

    3.2 Sensitivity ..... 4

    3.3 Isotropy ..... 5

    3.4 Probe Modulation Response ..... 5

4 Measurement Uncertainty ..... 5

5 Calibration Measurement Results ..... 5

    5.1 Sensitivity in air ..... 6

    5.2 Linearity ..... 7

    5.3 Isotropy ..... 7

6 List of Equipment ..... 8



## 1 DEVICE UNDER TEST

| Device Under Test                        |   |
|--|---|
| Device Type                              | COMOHAC E FIELD PROBE   |
| Manufacturer                             | MVG   |
| Model                                    | SCE   |
| Serial Number                            | SN 31/10 EPH22  |
| Product Condition (new / used)           | used  |
| Frequency Range of Probe                 | 0.7GHz-2.5GHz   |
| Resistance of Three Dipoles at Connector | Dipole 1: R1=1.293 MΩ<br>Dipole 2: R2=1.130 MΩ<br>Dipole 3: R3=1.320 MΩ |

A yearly calibration interval is recommended.

## 2 PRODUCT DESCRIPTION

### 2.1 GENERAL INFORMATION

MVG's COMOHAC E field Probes are built in accordance to the ANSI C63.19 and IEEE 1309 standards.



Figure 1 – MVG COMOHAC E field Probe

|  |        |
|--|--------|
| Probe Length                               | 330 mm |
| Length of Individual Dipoles               | 3.3 mm |
| Maximum external diameter                  | 8 mm   |
| Probe Tip External Diameter                | 5 mm   |
| Distance between dipoles / probe extremity | 3 mm   |

## 3 MEASUREMENT METHOD

All methods used to perform the measurements and calibrations comply with the ANSI C63.19 and IEEE 1309 standards.

### 3.1 LINEARITY

The linearity was determined using a standard dipole with the probe positioned 10 mm above the dipole. The input power of the dipole was adjusted from -15 to 36 dBm using a 1dB step (to cover the range 2V/m to 1000A/m).

### 3.2 SENSITIVITY

The sensitivity factors of the three dipoles were determined using the waveguide method outlined in the fore mentioned standards.



### 3.3 ISOTROPY

The axial isotropy was evaluated by exposing the probe to a reference wave from a standard dipole. The probe was rotated along its main axis from 0 - 360 degrees in 15 degree steps.

### 3.4 PROBE MODULATION RESPONSE

The modulation factor was determined by illuminating the probe with a reference wave from a standard dipole 10 mm away, applying first a CW signal and then a modulated signal (both at same power level). The modulation factor is the ratio, in linear units, of the CW to modulated signal reading.

## 4 MEASUREMENT UNCERTAINTY

The guidelines outlined in the IEEE 1528 and IEC/CEI 62209 standards were followed to generate the measurement uncertainty associated with an E-field probe calibration using the waveguide technique. All uncertainties listed below represent an expanded uncertainty expressed at approximately the 95% confidence level using a coverage factor of k=2, traceable to the Internationally Accepted Guides to Measurement Uncertainty.

| Uncertainty analysis of the probe calibration in waveguide |                       |                          |            |    |                          |
|--|-----------------------|--------------------------|------------|----|--------------------------|
| ERROR SOURCES  | Uncertainty value (%) | Probability Distribution | Divisor    | ci | Standard Uncertainty (%) |
| Incident or forward power                                  | 3.00%                 | Rectangular              | $\sqrt{3}$ | 1  | 1.732%                   |
| Reflected power  | 3.00%                 | Rectangular              | $\sqrt{3}$ | 1  | 1.732%                   |
| Field homogeneity  | 3.00%                 | Rectangular              | $\sqrt{3}$ | 1  | 1.732%                   |
| Field probe positioning                                    | 5.00%                 | Rectangular              | $\sqrt{3}$ | 1  | 2.887%                   |
| Field probe linearity                                      | 3.00%                 | Rectangular              | $\sqrt{3}$ | 1  | 1.732%                   |
| <b>Combined standard uncertainty</b>                       |                       |                          |            |    | 4.509%                   |
| <b>Expanded uncertainty</b><br>95 % confidence level k = 2 |                       |                          |            |    | 9.018%                   |

## 5 CALIBRATION MEASUREMENT RESULTS

| Calibration Parameters |       |
|------------------------|-------|
| Lab Temperature        | 22 °C |
| Lab Humidity           | 43 %  |



5.1 SENSITIVITY IN AIR

| Normx dipole 1<br>( $\mu\text{V}/(\text{V}/\text{m})^2$ ) | Normy dipole 2<br>( $\mu\text{V}/(\text{V}/\text{m})^2$ ) | Normz dipole 3<br>( $\mu\text{V}/(\text{V}/\text{m})^2$ ) |
|---|---|---|
| 4.91  | 5.70  | 4.97  |

| DCP dipole 1<br>(mV) | DCP dipole 2<br>(mV) | DCP dipole 3<br>(mV) |
|----------------------|----------------------|----------------------|
| 129                  | 126                  | 118                  |

Calibration curves

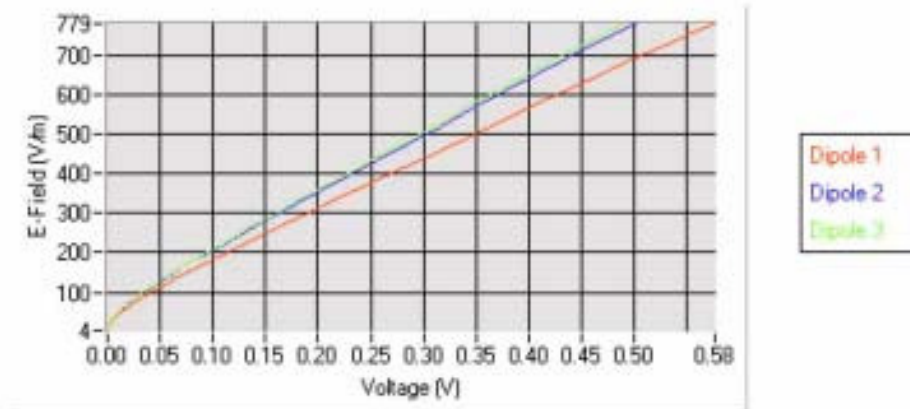



5.2 LINEARITY

Linearity

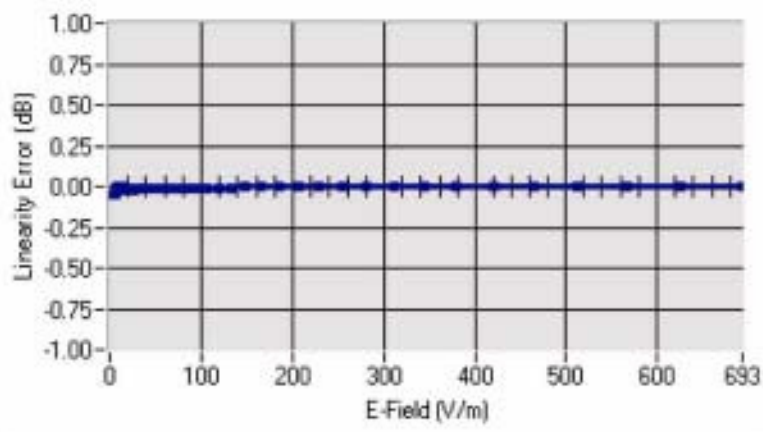

Linearity:  $\pm 1.09\%$  ( $\pm 0.05\text{dB}$ )

5.3 ISOTROPY

Isotropy curve

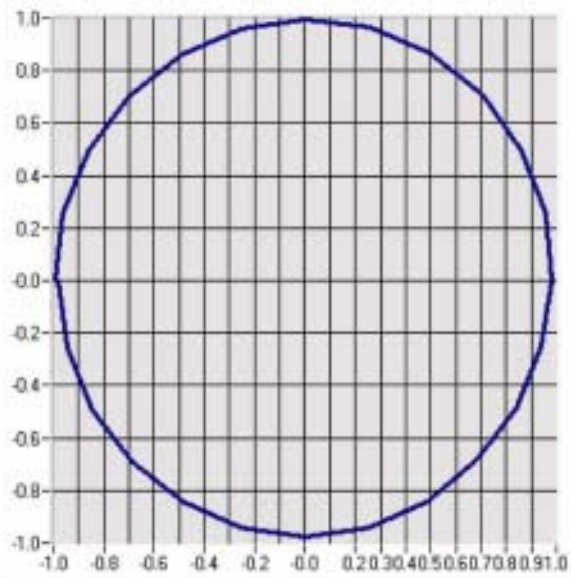

Isotropy:  $\pm 1.64\%$  ( $\pm 0.07\text{dB}$ )



## 6 LIST OF EQUIPMENT

| Equipment Summary Sheet       |                      |                    |   |   |
|-------------------------------|----------------------|--------------------|---|---|
| Equipment Description         | Manufacturer / Model | Identification No. | Current Calibration Date                      | Next Calibration Date                         |
| HAC positioning ruler         | MVG                  | TABH12 SN 42/09    | Validated. No cal required.                   | Validated. No cal required.                   |
| COMOHAC Test Bench            | Version 2            | NA                 | Validated. No cal required.                   | Validated. No cal required.                   |
| Network Analyzer              | Rhode & Schwarz ZVA  | SN100132           | 02/2013                                       | 02/2016                                       |
| Reference Probe               | MVG                  | EPH28 SN 08/11     | Characterized prior to test. No cal required. | Characterized prior to test. No cal required. |
| Reference Probe               | MVG                  | HPH38 SN31/10      | Characterized prior to test. No cal required. | Characterized prior to test. No cal required. |
| Multimeter                    | Keithley 2000        | 1188656            | 11/2013                                       | 11/2016                                       |
| Signal Generator              | Agilent E4438C       | MY49070581         | 12/2013                                       | 12/2016                                       |
| Amplifier                     | Aethercomm           | SN 046             | Characterized prior to test. No cal required. | Characterized prior to test. No cal required. |
| Power Meter                   | HP E4418A            | US38261498         | 11/2013                                       | 11/2016                                       |
| Power Sensor                  | HP ECP-E26A          | US37181460         | 11/2013                                       | 11/2016                                       |
| Directional Coupler           | Narda 4216-20        | 01386              | Characterized prior to test. No cal required. | Characterized prior to test. No cal required. |
| Waveguide                     | Mega Industries      | 069Y7-158-13-712   | Validated. No cal required.                   | Validated. No cal required.                   |
| Waveguide Transition          | Mega Industries      | 069Y7-158-13-701   | Validated. No cal required.                   | Validated. No cal required.                   |
| Waveguide Termination         | Mega Industries      | 069Y7-158-13-701   | Validated. No cal required.                   | Validated. No cal required.                   |
| Temperature / Humidity Sensor | Control Company      | 11-661-9           | 3/2014  | 3/2016  |



|             |                 |
|-------------|-----------------|
| Test Report | 16070898-HAC-RF |
| Page        | 33 of 48        |



## HAC Reference Dipole Calibration Report

Ref: ACR.301.3.13.SATU.A

### SIEMIC TESTING AND CERTIFICATION SERVICES

SUITE 311, BUILDING 1, SECTION 30 ,NO.2 KEFA ROAD,  
SCIENCE AND TECHNOLOGY PARK  
NAN SHAN DISTRICT, SHENZHEN 518057 , GUANGDONG  
,P.R.C.

### SATIMO COMOHAC REFERENCE DIPOLE

FREQUENCY: 800-950MHZ  
SERIAL NO.: SN 24/11 DHA31

Calibrated at SATIMO US  
2105 Barrett Park Dr. • Kennesaw, GA 30144





10/28/2014

#### Summary:

This document presents the method and results from an accredited HAC reference dipole calibration performed in SATIMO USA using the COMOHAC test bench. All calibration results are traceable to national metrology institutions.

|             |                 |
|-------------|-----------------|
| Test Report | 16070898-HAC-RF |
| Page        | 34 of 48        |



|                      | <i>Name</i>   | <i>Function</i> | <i>Date</i> | <i>Signature</i>  |
|----------------------|---------------|-----------------|-------------|---|
| <i>Prepared by :</i> | Jérôme LUC    | Product Manager | 10/28/2014  |  |
| <i>Checked by :</i>  | Jérôme LUC    | Product Manager | 10/28/2014  |  |
| <i>Approved by :</i> | Kim RUTKOWSKI | Quality Manager | 10/28/2014  |  |

|                       |   |
|-----------------------|---|
|                       | <i>Customer Name</i>                      |
| <i>Distribution :</i> | SIEMIC Testing and Certification Services |

| <i>Issue</i> | <i>Date</i> | <i>Modifications</i> |
|--------------|-------------|----------------------|
| A            | 10/28/2013  | Initial release      |
|              |             |                      |
|              |             |                      |
|              |             |                      |



**TABLE OF CONTENTS**

1 Introduction..... 4

2 Device Under Test..... 4

3 Product Description ..... 4

    3.1 General Information ..... 4

4 Measurement Method ..... 4

    4.1 Return Loss Requirements ..... 5

    4.2 Reference Dipole Calibration ..... 5

5 Measurement Uncertainty ..... 5

    5.1 Return Loss ..... 5

    5.2 Validation Measurement ..... 5

6 Calibration Measurement Results ..... 6

    6.1 Return Loss ..... 6

    6.2 Validation measurement ..... 6

7 List of Equipment ..... 8



**1 INTRODUCTION**

This document contains a summary of the requirements set forth by the ANSI C63.19 standard for reference dipoles used for HAC measurement system validations and the measurements that were performed to verify that the product complies with the fore mentioned standards.

**2 DEVICE UNDER TEST**

| Device Under Test              |                                      |
|--------------------------------|--------------------------------------|
| Device Type                    | COMOHAC 800-950 MHz REFERENCE DIPOLE |
| Manufacturer                   | Satimo                               |
| Model                          | SIDB835                              |
| Serial Number                  | SN 24/11 DHA31                       |
| Product Condition (new / used) | Used                                 |

A yearly calibration interval is recommended.

**3 PRODUCT DESCRIPTION**

**3.1 GENERAL INFORMATION**

Satimo’s COMOHAC Validation Dipoles are built in accordance to the ANSI C63.19 standard. The product is designed for use with the COMOHAC system only.



Figure 1 – Satimo COMOHAC Validation Dipole

**4 MEASUREMENT METHOD**

The ANSI C63.19 standard outlines the requirements for reference dipoles to be used for system validation measurements. The following measurements were performed to verify that the product complies with the fore mentioned standard.



#### 4.1 RETURN LOSS REQUIREMENTS

The dipole used for HAC system validation measurements and checks must have a return loss of -10 dB or better. The return loss measurement shall be performed in free space.

#### 4.2 REFERENCE DIPOLE CALIBRATION

The IEEE ANSI C63-19 standard states that the dipole used for validation measurements and checks must be scanned with the E and H field probe, with the dipole 10 mm below the probe. The E and H field strength plots are compared to the simulation results obtained by SATIMO.

### 5 MEASUREMENT UNCERTAINTY

All uncertainties listed below represent an expanded uncertainty expressed at approximately the 95% confidence level using a coverage factor of  $k=2$ , traceable to the Internationally Accepted Guides to Measurement Uncertainty.

#### 5.1 RETURN LOSS

The following uncertainties apply to the return loss measurement:

| Frequency band | Expanded Uncertainty on Gain |
|----------------|------------------------------|
| 400-6000MHz    | 0.1 dB                       |

#### 5.2 VALIDATION MEASUREMENT

The guideline outlined in the IEEE ANSI C63.19 standard was followed to generate the measurement uncertainty for validation measurements.

| Uncertainty analysis of the probe calibration in waveguide |                       |                          |            |                  |                          |
|--|-----------------------|--------------------------|------------|------------------|--------------------------|
| ERROR SOURCES  | Uncertainty value (%) | Probability Distribution | Divisor    | Uncertainty (dB) | Standard Uncertainty (%) |
| RF reflections   | 0.1                   | R                        | $\sqrt{3}$ | 0.06             |                          |
| Field probe conv. Factor                                   | 0.4                   | R                        | $\sqrt{3}$ | 0.23             |                          |
| Field probe anisotropy                                     | 0.25                  | R                        | $\sqrt{3}$ | 0.14             |                          |
| Positioning accuracy                                       | 0.2                   | R                        | $\sqrt{3}$ | 0.12             |                          |
| Probe cable placement                                      | 0.1                   | R                        | $\sqrt{3}$ | 0.06             |                          |
| System repeatability                                       | 0.2                   | R                        | $\sqrt{3}$ | 0.12             |                          |
| EUT repeatability  | 0.4                   | N                        | 1          | 0.40             |                          |
| Combined standard uncertainty                              |                       |                          |            | 0.52             |                          |
| Expanded uncertainty<br>95 % confidence level $k = 2$      |                       |                          |            | 1.00             | 13.0                     |



## 6 CALIBRATION MEASUREMENT RESULTS

### 6.1 RETURN LOSS

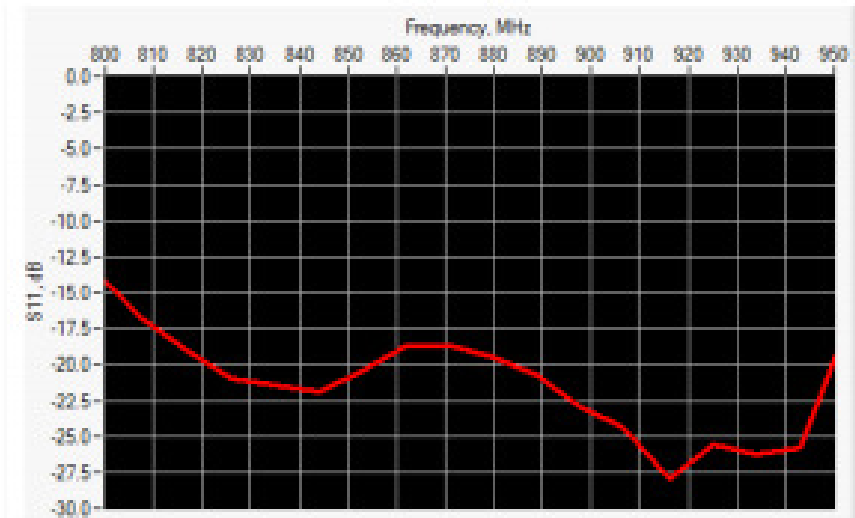

| Frequency (MHz) | Worst Case Return Loss (dB) | Requirement (dB) |
|-----------------|-----------------------------|------------------|
| 800-950 MHz     | -14.60                      | -10              |

### 6.2 VALIDATION MEASUREMENT

The IEEE ANSI C63.19 standard states that the system validation measurements must be performed using a reference dipole meeting the fore mentioned return loss requirements. The system validations measurement results are then compared to SATIMO’s simulated results.

#### Measurement Condition

|   |                 |
|---|-----------------|
| Software Version                          | OpenHAC V2      |
| HAC positioning ruler                     | SN 42/09 TABH12 |
| E-Field probe                             | SN 08/11 EPH28  |
| H-Field probe                             | SN 31/10 HPH38  |
| Distance between dipole and sensor center | 10 mm           |
| E-field scan size                         | X=150mm/Y=20mm  |
| H-field scan size                         | X=40mm/Y=20mm   |
| Scan resolution                           | dx=5mm/dy=5mm   |
| Frequency                                 | 835 MHz         |
| Input power                               | 20 dBm          |
| Lab Temperature                           | 21°C            |
| Lab Humidity                              | 45%             |



**Measurement Result**

|                      | Measured | Internal Requirement |
|----------------------|----------|----------------------|
| <b>E field (V/m)</b> | 218.70   | 220.4                |
| <b>H field (A/m)</b> | 0.45     | 0.445                |

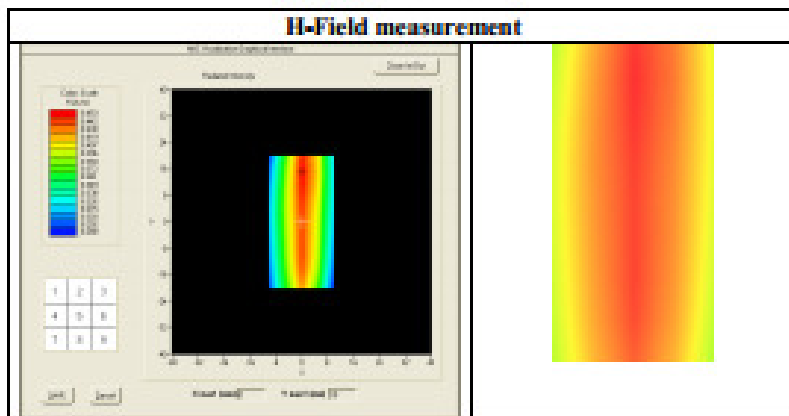
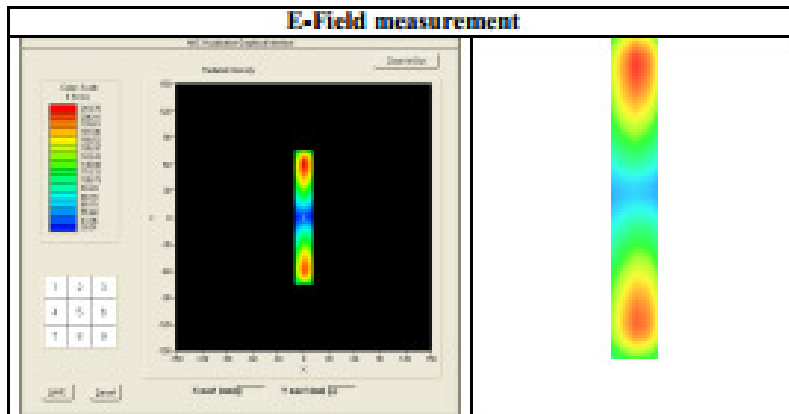



## 7 LIST OF EQUIPMENT

| Equipment Summary Sheet         |                      |                    |   |   |
|---------------------------------|----------------------|--------------------|---|---|
| Equipment Description           | Manufacturer / Model | Identification No. | Current Calibration Date                      | Next Calibration Date                         |
| HAC positioning ruler           | Satimo               | TABH12 SN 42/09    | Validated. No cal required.                   | Validated. No cal required.                   |
| COMOHAC Test Bench              | Version 2            | NA                 | Validated. No cal required.                   | Validated. No cal required.                   |
| Network Analyzer                | Rhode & Schwarz ZVA  | SN100132           | 02/2013                                       | 02/2016                                       |
| Reference Probe                 | Satimo               | EPH28 SN 08/11     | Characterized prior to test. No cal required. | Characterized prior to test. No cal required. |
| Reference Probe                 | Satimo               | HPH38 SN31/10      | Characterized prior to test. No cal required. | Characterized prior to test. No cal required. |
| Multimeter                      | Keithley 2000        | 1188656            | 11/2013                                       | 11/2016                                       |
| Signal Generator                | Agilent E4438C       | MY49070581         | 12/2013                                       | 12/2016                                       |
| Amplifier                       | Aethercomm           | SN 046             | Characterized prior to test. No cal required. | Characterized prior to test. No cal required. |
| Power Meter                     | HP E4418A            | US38261498         | 11/2013                                       | 11/2016                                       |
| Power Sensor                    | HP ECP-E26A          | US37181460         | 11/2013                                       | 11/2016                                       |
| Directional Coupler             | Narda 4216-20        | 01386              | Characterized prior to test. No cal required. | Characterized prior to test. No cal required. |
| Temperature and Humidity Sensor | Control Company      | 11-661-8           | 3/2014  | 3/2016  |





## HAC Reference Dipole Calibration Report

Ref : ACR.301.4.13.SATUA

### **SIEMIC TESTING AND CERTIFICATION SERVICES**

**SUITE 311, BUILDING 1, SECTION 30 ,NO.2 KEFA ROAD,  
SCIENCE AND TECHNOLOGY PARK  
NAN SHAN DISTRICT, SHENZHEN 518057 , GUANGDONG  
,P.R.C.**

### **SATIMO COMOHAC REFERENCE DIPOLE**

**FREQUENCY: 1700-2000MHZ**

**SERIAL NO.: SN 24/11 DHB32**

**Calibrated at SATIMO US**

**2105 Barrett Park Dr. - Kennesaw, GA 30144**





**10/28/2014**

#### *Summary:*

This document presents the method and results from an accredited HAC reference dipole calibration performed in SATIMO USA using the COMOHAC test bench. All calibration results are traceable to national metrology institutions.



|                      | <i>Name</i>   | <i>Function</i> | <i>Date</i> | <i>Signature</i>  |
|----------------------|---------------|-----------------|-------------|---|
| <i>Prepared by :</i> | Jérôme LUC    | Product Manager | 10/28/2014  |  |
| <i>Checked by :</i>  | Jérôme LUC    | Product Manager | 10/28/2014  |  |
| <i>Approved by :</i> | Kim RUTKOWSKI | Quality Manager | 10/28/2014  |  |

|                       |   |
|-----------------------|---|
|                       | <i>Customer Name</i>                      |
| <i>Distribution :</i> | SIEMIC Testing and Certification Services |

| <i>Issue</i> | <i>Date</i> | <i>Modifications</i> |
|--------------|-------------|----------------------|
| A            | 10/28/2013  | Initial release      |
|              |             |                      |
|              |             |                      |
|              |             |                      |



**TABLE OF CONTENTS**

|     |                                      |   |
|-----|--------------------------------------|---|
| 1   | Introduction.....                    | 4 |
| 2   | Device Under Test.....               | 4 |
| 3   | Product Description.....             | 4 |
| 3.1 | General Information.....             | 4 |
| 4   | Measurement Method.....              | 4 |
| 4.1 | Return Loss Requirements.....        | 5 |
| 4.2 | Reference Dipole Calibration.....    | 5 |
| 5   | Measurement Uncertainty.....         | 5 |
| 5.1 | Return Loss.....                     | 5 |
| 5.2 | Validation Measurement.....          | 5 |
| 6   | Calibration Measurement Results..... | 6 |
| 6.1 | Return Loss.....                     | 6 |
| 6.2 | Validation measurement.....          | 6 |
| 7   | List of Equipment.....               | 8 |

**1 INTRODUCTION**

This document contains a summary of the requirements set forth by the ANSI C63.19 standard for reference dipoles used for HAC measurement system validations and the measurements that were performed to verify that the product complies with the fore mentioned standards.

**2 DEVICE UNDER TEST**

| Device Under Test              |  |
|--------------------------------|--|
| Device Type                    | COMOHAC 1700-2000 MHz REFERENCE DIPOLE |
| Manufacturer                   | Satimo                                 |
| Model                          | SIDB1900                               |
| Serial Number                  | SN 24/11 DHB32                         |
| Product Condition (new / used) | Used                                   |

A yearly calibration interval is recommended.

**3 PRODUCT DESCRIPTION**

**3.1 GENERAL INFORMATION**

Satimo’s COMOHAC Validation Dipoles are built in accordance to the ANSI C63.19 standard. The product is designed for use with the COMOHAC system only.



**Figure 1 – Satimo COMOHAC Validation Dipole**

**4 MEASUREMENT METHOD**

The ANSI C63.19 standard outlines the requirements for reference dipoles to be used for system validation measurements. The following measurements were performed to verify that the product complies with the fore mentioned standard.

#### 4.1 RETURN LOSS REQUIREMENTS

The dipole used for HAC system validation measurements and checks must have a return loss of -10 dB or better. The return loss measurement shall be performed in free space.

#### 4.2 REFERENCE DIPOLE CALIBRATION

The IEEE ANSI C63-19 standard states that the dipole used for validation measurements and checks must be scanned with the E and H field probe, with the dipole 10 mm below the probe. The E and H field strength plots are compared to the simulation results obtained by SATIMO.

### 5 MEASUREMENT UNCERTAINTY

All uncertainties listed below represent an expanded uncertainty expressed at approximately the 95% confidence level using a coverage factor of  $k=2$ , traceable to the Internationally Accepted Guides to Measurement Uncertainty.

#### 5.1 RETURN LOSS

The following uncertainties apply to the return loss measurement:

| Frequency band | Expanded Uncertainty on Gain |
|----------------|------------------------------|
| 400-6000MHz    | 0.1 dB                       |

#### 5.2 VALIDATION MEASUREMENT

The guideline outlined in the IEEE ANSI C63.19 standard was followed to generate the measurement uncertainty for validation measurements.

| Uncertainty analysis of the probe calibration in waveguide               |                       |                          |            |                  |                          |
|--|-----------------------|--------------------------|------------|------------------|--------------------------|
| ERROR SOURCES  | Uncertainty value (%) | Probability Distribution | Divisor    | Uncertainty (dB) | Standard Uncertainty (%) |
| RF reflections   | 0.1                   | R                        | $\sqrt{3}$ | 0.06             |                          |
| Field probe corr. Factor   | 0.4                   | R                        | $\sqrt{3}$ | 0.23             |                          |
| Field probe anisotropy   | 0.25                  | R                        | $\sqrt{3}$ | 0.14             |                          |
| Positioning accuracy   | 0.2                   | R                        | $\sqrt{3}$ | 0.12             |                          |
| Probe cable placement  | 0.1                   | R                        | $\sqrt{3}$ | 0.06             |                          |
| System repeatability   | 0.2                   | R                        | $\sqrt{3}$ | 0.12             |                          |
| EUT repeatability  | 0.4                   | N                        | 1          | 0.40             |                          |
| <b>Combined standard uncertainty</b>                                     |                       |                          |            | <b>0.52</b>      |                          |
| <b>Expanded uncertainty<br/>95 % confidence level <math>k = 2</math></b> |                       |                          |            | <b>1.00</b>      | <b>13.0</b>              |



## 6 CALIBRATION MEASUREMENT RESULTS

### 6.1 RETURN LOSS

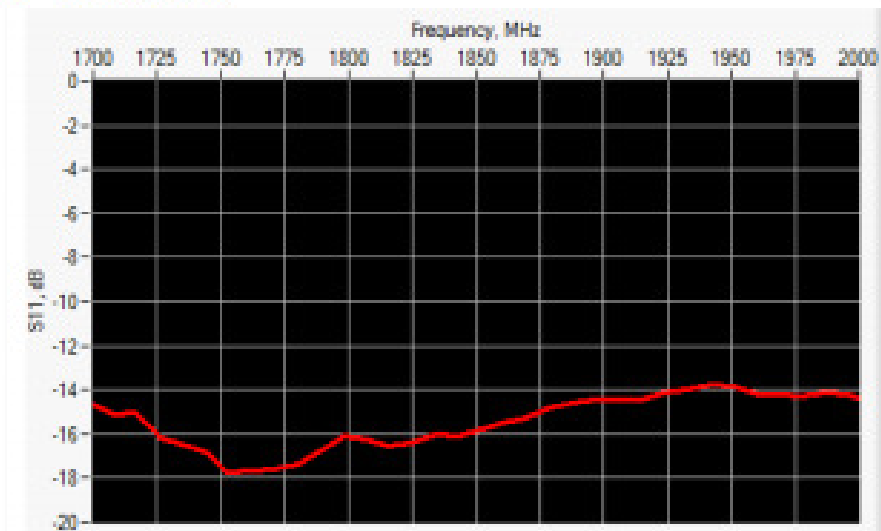

| Frequency (MHz) | Worst Case Return Loss (dB) | Requirement (dB) |
|-----------------|-----------------------------|------------------|
| 1700-2000 MHz   | -13.72                      | -10              |

### 6.2 VALIDATION MEASUREMENT

The IEEE ANSI C63.19 standard states that the system validation measurements must be performed using a reference dipole meeting the fore mentioned return loss requirements. The system validations measurement results are then compared to SATIMO's simulated results.

#### Measurement Condition

|   |                 |
|---|-----------------|
| Software Version                          | OpenHAC V2      |
| HAC positioning ruler                     | SN 42/09 TABH12 |
| E-Field probe                             | SN 08/11 EPH28  |
| H-Field probe                             | SN 31/10 HPH38  |
| Distance between dipole and sensor center | 10 mm           |
| E-field scan size                         | X=150mm/Y=20mm  |
| H-field scan size                         | X=40mm/Y=20mm   |
| Scan resolution                           | dx=5mm/dy=5mm   |
| Frequency                                 | 1900 MHz        |
| Input power                               | 20 dBm          |
| Lab Temperature                           | 21°C            |
| Lab Humidity                              | 45%             |

**Measurement Result**

|                      | <b>Measured</b> | <b>Internal Requirement</b> |
|----------------------|-----------------|-----------------------------|
| <b>E field (V/m)</b> | <b>147.65</b>   | <b>153.4</b>                |
| <b>H field (A/m)</b> | <b>0.47</b>     | <b>0.445</b>                |

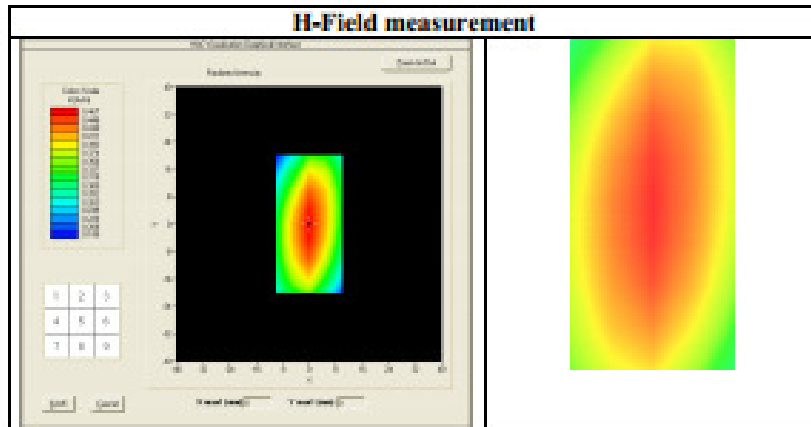
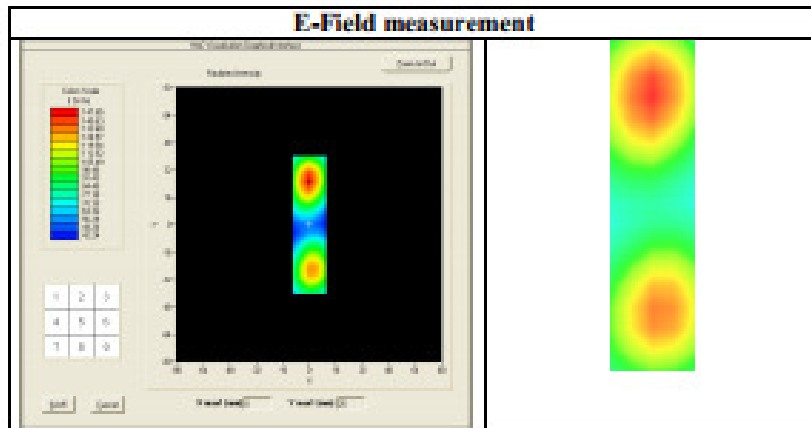



## 7 LIST OF EQUIPMENT

| Equipment Summary Sheet         |                      |                    |   |   |
|---------------------------------|----------------------|--------------------|---|---|
| Equipment Description           | Manufacturer / Model | Identification No. | Current Calibration Date                      | Next Calibration Date                         |
| HAC positioning ruler           | Satimo               | TABH12 SN 42/09    | Validated. No cal required.                   | Validated. No cal required.                   |
| COMOHAC Test Bench              | Version 2            | NA                 | Validated. No cal required.                   | Validated. No cal required.                   |
| Network Analyzer                | Rhode & Schwarz ZVA  | SN100132           | 02/2013                                       | 02/2016                                       |
| Reference Probe                 | Satimo               | EPH28 SN 08/11     | Characterized prior to test. No cal required. | Characterized prior to test. No cal required. |
| Reference Probe                 | Satimo               | HPH38 SN31/10      | Characterized prior to test. No cal required. | Characterized prior to test. No cal required. |
| Multimeter                      | Keithley 2000        | 1188656            | 11/2013                                       | 11/2016                                       |
| Signal Generator                | Agilent E4438C       | MY49070581         | 12/2013                                       | 12/2016                                       |
| Amplifier                       | Aethercomm           | SN 046             | Characterized prior to test. No cal required. | Characterized prior to test. No cal required. |
| Power Meter                     | HP E4418A            | US38261496         | 11/2013                                       | 11/2016                                       |
| Power Sensor                    | HP ECP-E26A          | US37181460         | 11/2013                                       | 11/2016                                       |
| Directional Coupler             | Narda 4216-20        | 01386              | Characterized prior to test. No cal required. | Characterized prior to test. No cal required. |
| Temperature and Humidity Sensor | Control Company      | 11-661-9           | 3/2014  | 3/2016  |