



FCC HAC (T-Coil) Test Report

Report No: HR/2019/90003
Applicant: Unimax communications
Manufacturer: Unimax communications
Factory: Unimax communications
Product Name: Smartphone
Model No.(EUT): U693CL
Trade Mark: UMX
FCC ID: P46-U693CL
Standards: ANSI C63.19-2011
CFR 47 FCC Part 20
Date of Receipt: 2019-11-05
Date of Test: 2019-11-16 to 2019-12-12
Date of Issue: 2019-12-15
Test conclusion: **PASS ***

* In the configuration tested, the EUT detailed in this report complied with the standards specified above.

Authorized Signature:

Derek Yang

Wireless Laboratory Manager

The manufacturer should ensure that all products in series production are in conformity with the product sample detailed in this report.

If the product in this report is used in any configuration other than that detailed in the report, the manufacturer must ensure the new system complies with all relevant standards. Any mention of SGS International Electrical Approvals or testing done by SGS International Electrical Approvals in connection with, distribution or use of the product described in this report must be approved by SGS International Electrical Approvals in writing.



REVISION HISTORY

Revision Record				
Version	Chapter	Date	Modifier	Remark
01		2019-12-15		Original

TEST SUMMARY

Frequency Band	T-rating
WCDMA Band II	T4
WCDMA Band IV	T4
WCDMA Band V	T4
CDMA BC0	T3
CDMA BC1	T3
CDMA BC10	T4
LTE Band 2/25	T3
LTE Band 4/66	T3
LTE Band 5/26	T3
LTE Band 12	T3
LTE Band 71	T3
LTE Band 41	T3
WiFi2.4G	T3
HAC Rate Category:	T3

Note: The device have similar frequency in some LTE bands: LTE 2/25, 4/66, B5/26, since the supported frequency spans for the smaller LTE bands are completely cover by the larger LTE bands, therefore, only larger LTE bands were required to be tested for hearing-aid compliance.

Approved & Released by

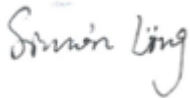

Simon Ling

SAR Manager

Tested by

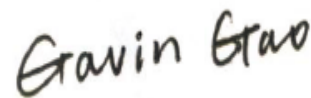

Gavin Gao

SAR Engineer



CONTENTS

1	GENERAL INFORMATION	5
1.1	INTRODUCTION	5
1.2	DETAILS OF CLIENT	5
1.3	TEST LOCATION	6
1.4	TEST FACILITY	6
1.5	GENERAL DESCRIPTION OF EUT	7
1.5.1	DUT Antenna Locations	8
1.5.2	List of air interfaces/frequency bands	9
1.6	TEST SPECIFICATION	10
2	CALIBRATION CERTIFICATE	10
3	HAC (T COIL) MEASUREMENT SYSTEM	11
3.1	MEASUREMENT SYSTEM DIAGRAM FOR SPEAG ROBOTIC	11
3.2	T-COIL MEASUREMENT SET-UP	12
3.3	SYSTEM CALIBRATION	13
3.4	AUDIO MAGNETIC PROBE AM1DV3	14
3.5	TEST ARCH.	14
3.6	PHONE HOLDER	14
3.7	AMCC- AUDIO MAGNETIC CALIBRATION COIL	15
3.8	AMMI - AUDIO MAGNETIC MEASUREMENT INSTRUMENT	15
4	MEASUREMENT UNCERTAINTY EVALUATION	16
5	HAC (T COIL) MEASUREMENT	17
5.1	T-COIL PERFORMANCE REQUIREMENTS	17
5.2	T-COIL MEASUREMENT POINTS AND REFERENCE PLANE	19
5.3	T-COIL MEASUREMENT PROCEDURE	20
6	T-COIL TESTING FOR CMRS VOICE	21
6.1	GENERAL DESCRIPTION	21
6.2	UMTS TESTS RESULTS	21
6.3	CDMA TESTS RESULTS	22
7	T-COIL TESTING FOR CMRS IP VOICE	23
7.1	VoLTE TESTS RESULTS	23
7.2	VoWiFi TESTS RESULTS	26
7.3	T-COIL TESTING FOR OTT VOIP APPLICATION	28
8	EQUIPMENT LIST	31
9	CALIBRATION CERTIFICATE	31
10	PHOTOGRAPHS	31
	APPENDIX A: DETAILED TEST RESULTS	31
	APPENDIX B: CALIBRATION CERTIFICATE	31
	APPENDIX C: PHOTOGRAPHS	31



1 General Information

1.1 Introduction

The purpose of this standard is to establish categories for hearing aids and for WD (wireless communications devices) that can indicate to health care practitioners and hearing aid users which hearing aids are compatible with which WD, and to provide tests that can be used to assess the electromagnetic characteristics of hearing aids and WD and assign them to these categories. The various parameters required, in order to demonstrate compatibility and accessibility are measured. The design of the standard is such that when a hearing aid and WD achieve one of the categories specified, as measured by the methodology of this standard, the indicated performance is realized.

In order to provide for the usability of a hearing aid with a WD, several factors must be coordinated:

- a) Radio frequency (RF) measurements of the near-field electric and magnetic fields emitted by a WD to categorize these emissions for correlation with the RF immunity of a hearing aid.
- b) Magnetic field measurements of a WD emitted via the audio transducer associated with the T-coil mode of the hearing aid, for assessment of hearing aid performance.
- c) Measurements with the hearing aid and a simulation of the categorized WD T-coil emissions to assess the hearing aid RF immunity in the T-coil mode.

The WD radio frequency (RF) and audio band emissions are measured.

Hence, the following are measurements made for the WD:

- a) RF E-Field emissions
- b) T-coil mode, magnetic signal strength in the audio band
- c) T-coil mode, magnetic signal and noise articulation index
- d) T-coil mode, magnetic signal frequency response through the audio band

Corresponding to the WD measurements, the hearing aid is measured for:

- a) RF immunity in microphone mode
- b) RF immunity in T-coil mode

1.2 Details of Client

Applicant:	Unimax communications
Address:	18201 McDermott St.West Suite E,Irvine,CA 92614.
Manufacturer:	Unimax communications
Address:	18201 McDermott St.West Suite E,Irvine,CA 92614.
Factory:	Unimax communications
Address:	18201 McDermott St.West Suite E,Irvine,CA 92614.



1.3 Test Location

Company: SGS-CSTC Standards Technical Services Co., Ltd. Xian Branch
Address: Unit D, Building 1, Kanghong Orange Science Park, 137 Keyuan Third Road, Fengdong New Town, Xi'an
Post code: 710086
Telephone: +86 512 36836182
Fax: +86 512 36836182

1.4 Test Facility

The test facility is recognized, certified, or accredited by the following organizations:

- **A2LA (Certificate No. 4854.01)**

SGS-CSTC Standards Technical Services Co., Ltd., Xi'an Branch is accredited by the American Association for Laboratory Accreditation(A2LA). Certificate No. 4854.01.

- **FCC –Designation Number: CN1271**

SGS-CSTC Standards Technical Services Co., Ltd., Xi'an Branch has been recognized as an accredited testing laboratory.

Designation Number: CN1271. Test Firm Registration Number: 637380.

- **Innovation, Science and Economic Development Canada**

SGS-CSTC Standards Technical Services Co., Ltd., Xi'an Branch has been recognized by ISED as an accredited testing laboratory.

CAB identifier: CN0095

ISED#: 25613.



1.5 General Description of EUT

Device Type :	portable device		
Exposure Category:	uncontrolled environment / general population		
Product Name:	Smartphone		
Model No.(EUT):	U693CL		
Trade Mark:	UMX		
Product Phase:	production unit		
FCC ID:	P46-U693CL		
IMEI:	99001565000134/ 99001565000191		
Hardware Version:	Q5009-V1.0		
Software Version:	U693CL_01.01.01.182518		
Antenna Type:	Inner Antenna		
Device Operating Configurations :			
Modulation Mode:	CDMA: QPSK; WCDMA: QPSK; LTE: QPSK,16QAM WIFI: DSSS, OFDM BT: GFSK, π/4DQPSK,8DPSK		
HSDPA UE Category:	14	HSUPA UE Category	6
DC-HSDPA UE Category:	24		
Power Class	3, tested with power control "all 1"(CDMA BC0/BC1/BC10)		
	3, tested with power control "all 1"(WCDMA Band II/IV/V)		
	3, tested with power control Max Power(LTE Band 2/4/5/12/25/26/66/71/41)		
Frequency Bands:	Band	Tx (MHz)	Rx (MHz)
	WCDMA Band II	1850~1910	1930~1990
	WCDMA Band IV	1710~1755	2110~2155
	WCDMA Band V	824~849	869~894
	CDMA BC0	824~849	869~894
	CDMA BC1	1850~1910	1930~1990
	CDMA BC10	806~824	851~869
	LTE Band 2	1850~1910	1930~1990
	LTE Band 4	1710~1755	2110~2155
	LTE Band 5	824~849	869~894
	LTE Band 12	699~716	729~746
	LTE Band 25	1850~1915	1930~1995
	LTE Band 26	814~849	859~894
	LTE Band 66	1710~1780	2110~2180
	LTE Band 71	663~698	617~652
	LTE Band 41	2496~2690	2496~2690
	WIFI 2.4G	2412~2462	2412~2462
	BT	2402~2480	2402~2480
Battery Information 1#:	Model:	U693CL	
	Normal Voltage:	3.85V	
	Rated capacity:	2000mAh	
	Manufacturer:	DONGGUAN MILEY ELECTRONIC CO.,LTD	

1.5.1 DUT Antenna Locations

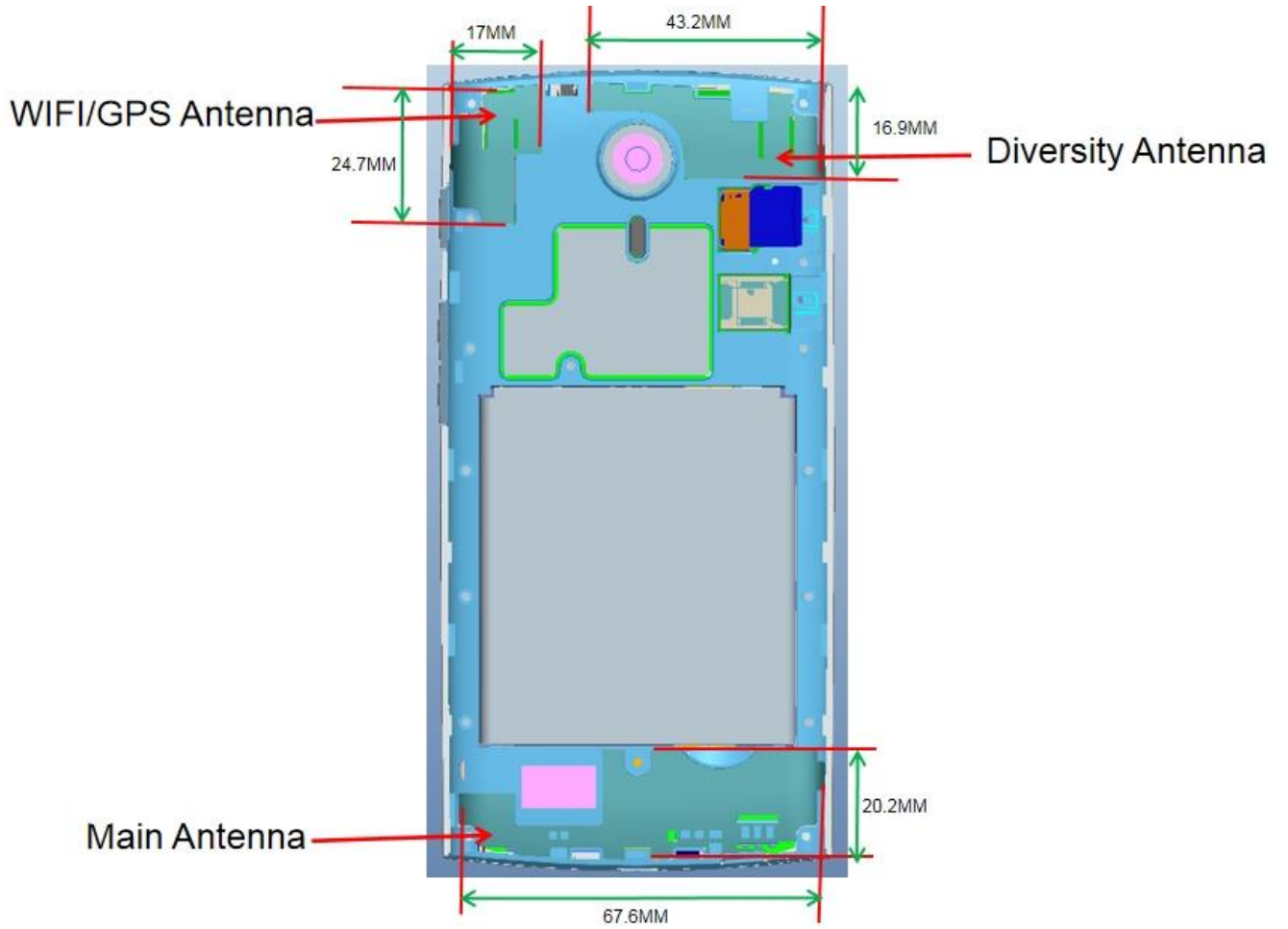



1.5.2 List of air interfaces/frequency bands

Air Interface	Band (MHz)	Type	ANSI C63.19 Tested	Simultaneous Transmitter	Name of Voice Service	Power Reduction
WCDMA	Band II	VO	Yes	BT, Wi-Fi	CMRS Voice	NA
	Band IV					
	Band V					
	HSPA	VD	Yes		Google Duo*	
CDMA	BC0	VO	Yes	BT, Wi-Fi	CMRS Voice	NA
	BC1					
	BC10					
	EVDO	VD	NA		NA	
LTE FDD	2	VD	Yes	BT or Wi-Fi	VoLTE* Google Duo**	NA
	4					
	5					
	12					
	25					
	26					
	66					
71						
LTE (TDD)	Band 41	VD	Yes	BT, Wi-Fi	VoLTE* Google Duo*	NA
Wi-Fi	2450	VD	Yes	WWAN	Wi-Fi calling* Google Duo*	NA
BT	2450	DT	NA	WWAN	NA	NA

VO: Legacy Cellular Voice Service from Table 7.1 in 7.4.2.1 of ANSI C63.19-2011

DT: Digital Transport (no voice)

VD: IP Voice Service over Digital Transport

* For protocols not listed in Table 7.1 of ANSI C63.19-2011 or the ANSI C63.19-2011 VoLTE interpretation, the average speech level of -20 dBm0 should be used.

Note: The device has similar frequency in some LTE bands: LTE 2/25, 4/66, B5/26, since the supported frequency spans for the smaller LTE bands are completely cover by the larger LTE bands, therefore, only larger LTE bands were required to be tested for hearing-aid compliance.



1.6 Test Specification

Identity	Document Title
CFR 47 FCC Part 20	§20.19 Hearing aid-compatible mobile handsets.
ANSI C63.19-2011	American National Standard for Methods of Measurement of Compatibility between Wireless Communication Devices
KDB 285076 D01	HAC Guidance v05
KDB 285076 D02	T-Coil testing v03
KDB 285076 D03	HAC FAQ v01

2 Calibration certificate

Temperature	Min. = 18°C, Max. = 25 °C
Relative humidity	Min. = 30%, Max. = 70%

Table 1: The Ambient Conditions

3 HAC (T Coil) Measurement System

3.1 Measurement System Diagram for SPEAG Robotic

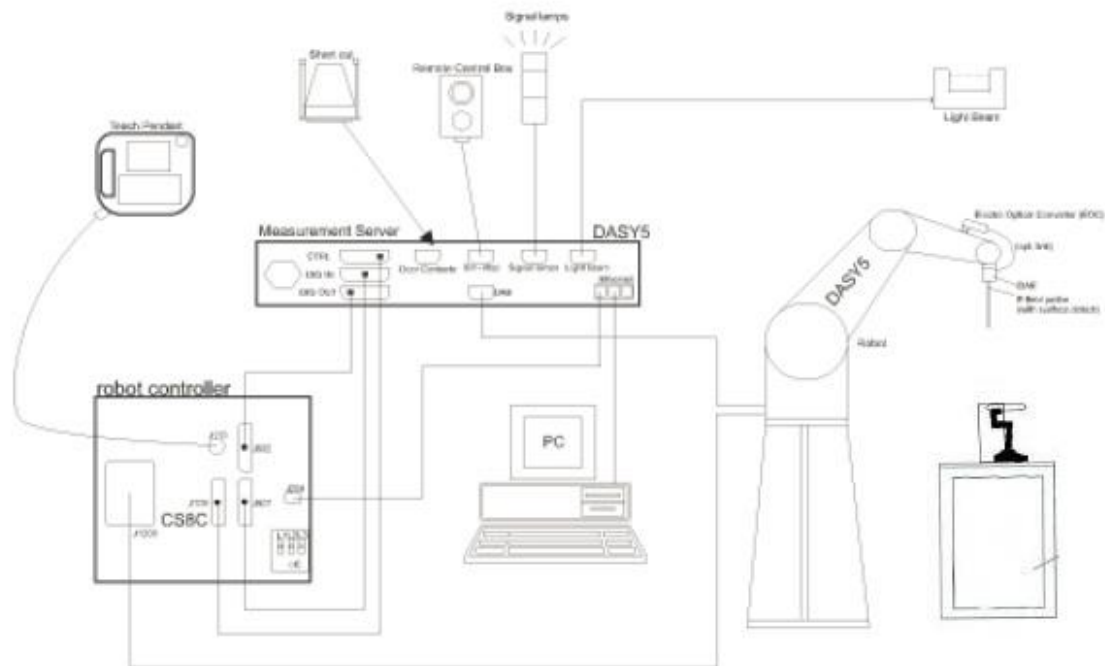

Fig. 1. The SPEAG Robotic Diagram

The DASY5 system for performing compliance tests consists of the following items:

- A standard high precision 6-axis robot (Stabile RX family) with controller, teach pendant and software. An arm extension is for accommodating the data acquisition electronics (DAE).
- An Audio Magnetic probe.
- A data acquisition electronics (DAE) which performs the signal amplification, signal multiplexing, AD-conversion, offset measurements, mechanical surface detection, collision detection, etc. The unit is battery powered with standard or rechargeable batteries. The signal is optically transmitted to the EOC.
- The Electro-optical converter (EOC) performs the conversion between optical and electrical of the signals for the digital communication to the DAE and for the analog signal from the optical surface detection. The EOC is connected to the measurement server.
- The function of the measurement server is to perform the time critical tasks such as signal filtering, control of the robot operation and fast movement interrupts.
- A probe alignment unit which improves the (absolute) accuracy of the probe positioning.
- A computer operating Windows 7.
- DASY5 software.
- Remote control with teach pendant and additional circuitry for robot safety such as warning lamps, etc.
- The Test Arch SAM phantom
- The device holder for handheld mobile phones.
- Validation dipole kits allowing to validate the proper functioning of the system.

3.2 T-Coil Measurement Set-up

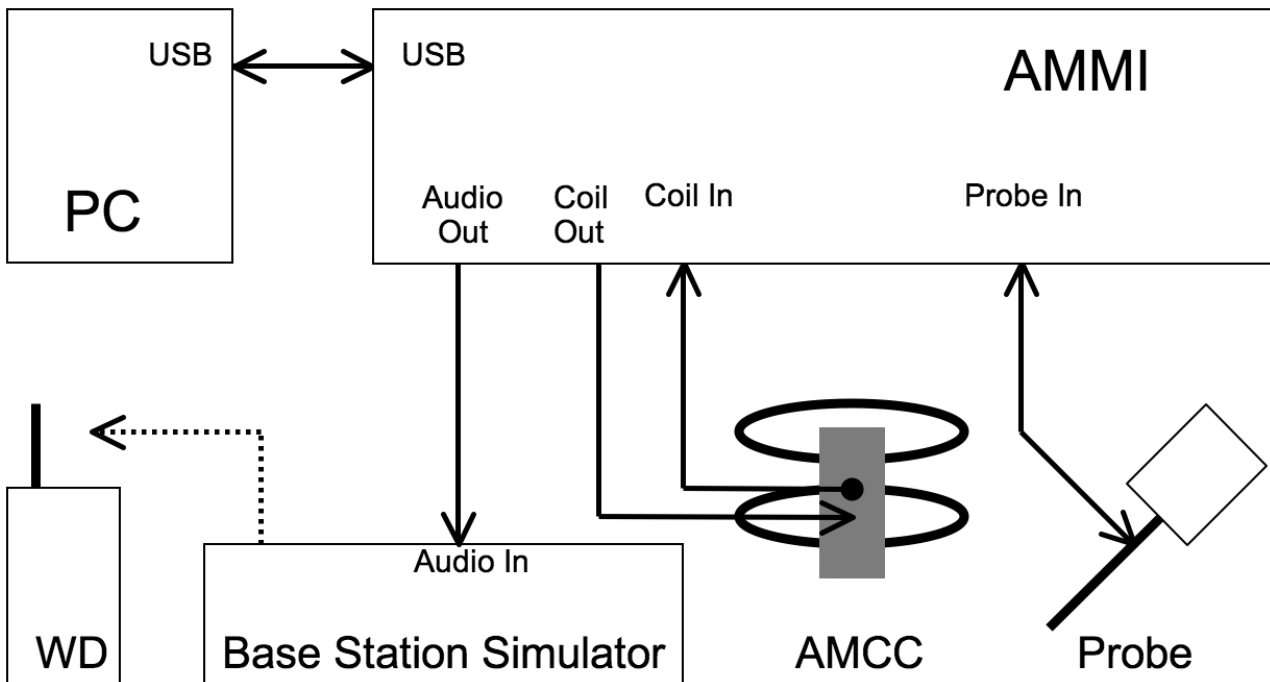

Fig. 2. T-coil signal measurement test setup

The sequence of the measurement is T-Coil testing procedure over a wireless communication device:

1. Confirm Geometry & signal check. Probe phantom alignment and check of accuracy.
2. Background noise measurement in the area of the WD.
3. Perform 50x50mm area scan with narrow band signal to determine ABM1, ABM2 and SNR for axial and radial orientation positions.
4. For Axial position, perform optimal SNR point measurement with a broadband signal – determine Frequency Response
5. Define the all applicable input audio level according to ANSI C63.19-2011 and KDB 285076 D02v03.

Note.

- #. The EUT do not use the special HAC SW.
- #. Setting the maximum volume for EUT during the measurement.
- #. For the measurement, it don't use the "post-test measurement processing of results".
- #. Per KDB 285076 D01v05, handsets that that have the ability to support concurrent connections using simultaneous transmissions shall be independently tested for each air interface/band given in ANSI C63.19-2011. At the present time ANSI C63.19 does not provide simultaneous transmission test procedures.

3.3 System Calibration

For correct and calibrated measurement of the voltages and ABM field, DASY will perform a calibration job as below.

In phase 1, the audio output is switched off, and a 200 mVpp symmetric rectangular signal of 1 kHz is generated and internally connected directly to both channels of the sampling unit (Coil in, Probe in).

In phase 2, the audio output is off, and a 20 mVpp symmetric 100 Hz signal is internally connected. The signals during phases 1 and 2 are available at the output on the rear panel of the AMMI. However, the output must not be loaded, in order to avoid influencing the calibration. An RMS voltmeter would indicate 100 mVRMS during the first phase and 10 mVRMS during the second phase. After the first two phases, the two input channels are both calibrated for absolute measurements of voltages. The resulting factors are displayed above the multi-meter window.

After phases 1 and 2, the input channels are calibrated to measure exact voltages. This is required to use the inputs for measuring voltages with their peak and RMS value.

In phase 3, a multi-sine signal covering each third-octave band from 50 Hz to 10 kHz is generated and applied to both audio outputs. The probe should be positioned in the center of the AMCC and aligned in the z-direction, the field orientation of the AMCC. The "Coil In" channel is measuring the voltage over the AMCC internal shunt, which is proportional to the magnetic field in the AMCC. At the same time, the "Probe In" channel samples the amplified signal picked up by the probe coil and provides it to a numerical integrator. The ratio of the two voltages in each third-octave filter leads to the spectral representation over the frequency band of interest. The Coil signal is scaled in dBV, and the Probe signal is first integrated and normalized to show dB A/m. The ratio probe-to-coil at the frequency of 1 kHz is the sensitivity which will be used in the consecutive T-Coil jobs.

3.4 Audio Magnetic Probe AM1DV3

Description	Active single sensor probe for both axial and radial measurement scans- Fully RF shielded, compatible with DAE, with adapted probe cup	 <p>AM1DV3 Audio Probe</p>
Dynamic Range	0.1 KHz to 20 KHz	
Sensitivity	<-50dB A/m @ 1KHz	
Internal Amp	20dB	
Dimensions	300X18mm	

3.5 Test Arch

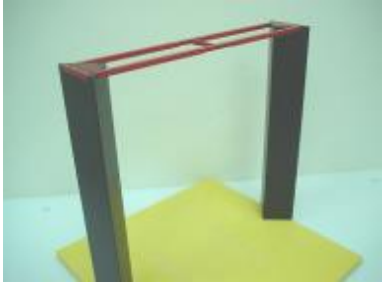
Description	Enables easy and well defined positioning of the phone and validation dipoles as well as simple teaching of the robot.	 <p>Test Arch</p>
Dimensions	length: 370 mm width: 370 mm height: 370 mm	

3.6 Phone Holder

Description	Supports accurate and reliable positioning of any phone Effect on near field <+/- 0.5 dB	 <p>Phone Holder</p>
-------------	--	---

3.7 AMCC- Audio Magnetic Calibration Coil

<p>Description</p>	<p>Allows calibration of the complete measurement setup, the two horizontal coils create a homogeneous magnetic field in the z direction. Refer to Appendix 5 for more detail on AMCC coil</p>	 <p>AMCC</p>
--------------------	--	---

3.8 AMMI - Audio Magnetic Measurement Instrument

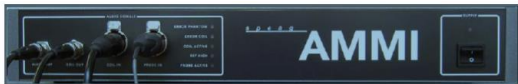
<p>Description</p>	<ul style="list-style-type: none"> -USB interface to PC - Probe signal digitization and power supply- Test signal generation for wireless device (via base station simulator)- Auto-calibration and interfaces to AMCC for complete setup-calibration 	 <p>AMMI</p>
<p>Data Rate</p>	<p>48 KHz / 24bit</p>	
<p>Dynamic Range</p>	<p>85 dB</p>	
<p>Dimensions:</p>	<p>19" X 65 X 270mm</p>	

4 Measurement uncertainty evaluation

Error Description	Uncertainty Value (%)	Probability Dist.	Divisor	ci ABM1	ci ABM2	Standard Uncertainty ABM1 (%)	Standard Uncertainty ABM2 (%)
Related to probe sensitivity							
Reference level	±3.0	R	$\sqrt{3}$	1	1	±3.0	±3.0
AMCC geometry	±0.4	R	$\sqrt{3}$	1	1	±0.2	±0.2
AMCC current	±0.6	R	$\sqrt{3}$	1	1	±0.4	±0.4
Probe positioning during calibration	±0.2	R	$\sqrt{3}$	1	1	±0.1	±0.1
Noise distribution	±0.7	R	$\sqrt{3}$	0.0143	1	±0.0	±0.4
Frequency slope	±5.9	R	$\sqrt{3}$	0.1	1	±0.3	±3.5
Related to probe system							
Repeatability / drift	±1.0	R	$\sqrt{3}$	1	1	±0.6	±0.6
Linearity / dynamic range	±0.6	N	1	1	1	±0.4	±0.4
Audio noise	±1.0	R	$\sqrt{3}$	0.1	1	±0.1	±0.6
Probe angle	±2.3	R	$\sqrt{3}$	1	1	±1.4	±1.4
Spectral Processing	±0.9	R	$\sqrt{3}$	1	1	±0.5	±0.5
Integration time	±0.6	N	1	1	5	±0.6	±3.0
Field distribution	±0.2	R	$\sqrt{3}$	1	1	±0.1	±0.1
Test signal							
Reference signal spectrum response	±0.6	R	$\sqrt{3}$	0	1	±0.0	±0.4
Positioning							
Probe positioning	±1.9	R	$\sqrt{3}$	1	1	±1.1	±1.1
Phantom Thickness	±0.9	R	$\sqrt{3}$	1	1	±0.5	±0.5
DUT positioning	±1.9	R	$\sqrt{3}$	1	1	±1.1	±1.1
External Contributions							
RF interference	±0.0	R	$\sqrt{3}$	1	0.3	±0.0	±0.0
Test Signal Variation	±2.0	R	$\sqrt{3}$	1	1	±1.2	±1.2
Combined Std. Uncertainty (ABM Field)	$u_c' = \sqrt{\sum_{i=1}^{20} c_i^2 u_i^2}$					±4.1	±6.2
Expanded Std. Uncertainty (K=2)						±8.2	±12.4

Table 2: Measurement uncertainties for T-Coil

5 HAC (T Coil) Measurement

5.1 T-Coil Performance Requirements

In order to be rated for T-Coil use, a WD shall meet the requirements for signal level and signal quality contained in this part.

1) T-Coil coupling field intensity

When measured as specified in ANSI C63.19, the T-Coil signal shall be ≥ -18 dB (A/m) at 1 kHz, in a 1/3 octave band filter for all orientations.

2) Frequency response

The frequency response of the axial component of the magnetic field, measured in 1/3 octave bands, shall follow the response curve specified in this sub-clause, over the frequency range 300 Hz to 3000 Hz. Figure 1 and Figure 2 provide the boundaries for the specified frequency.

These response curves are for true field strength measurements of the T-Coil signal. Thus the 6 dB/octave probe response has been corrected from the raw readings.

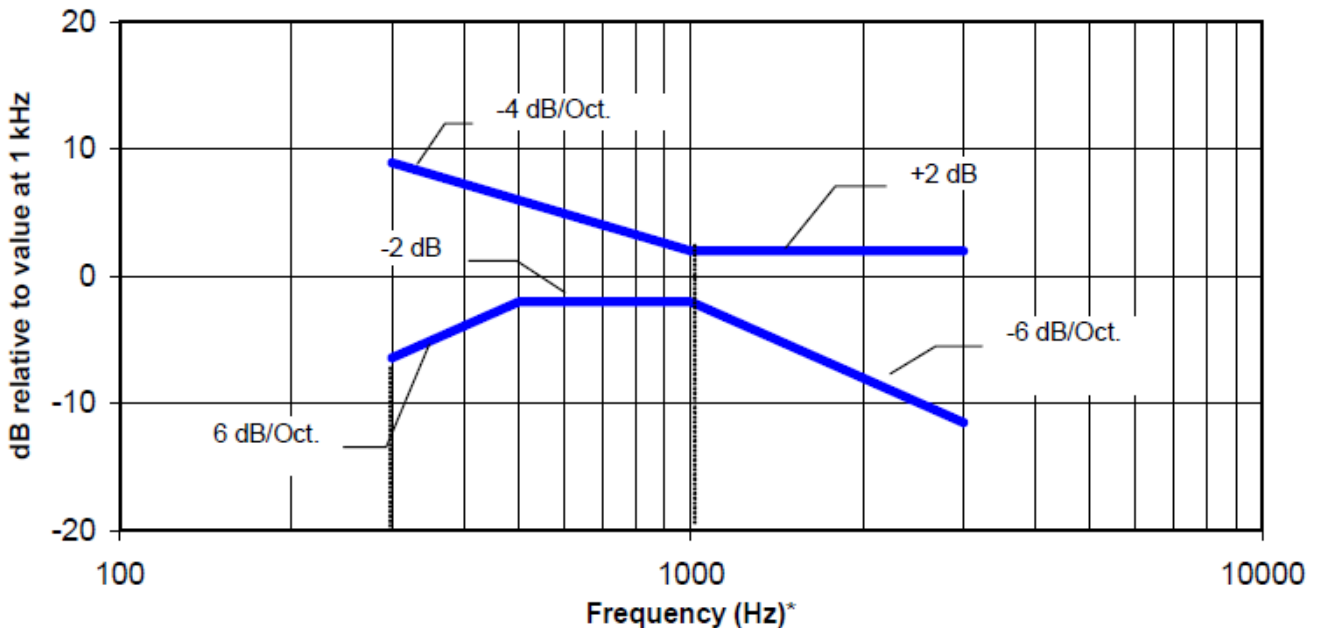

Figure 1—Magnetic field frequency response for WDs with a field ≤ -15 dB (A/m) at 1 kHz

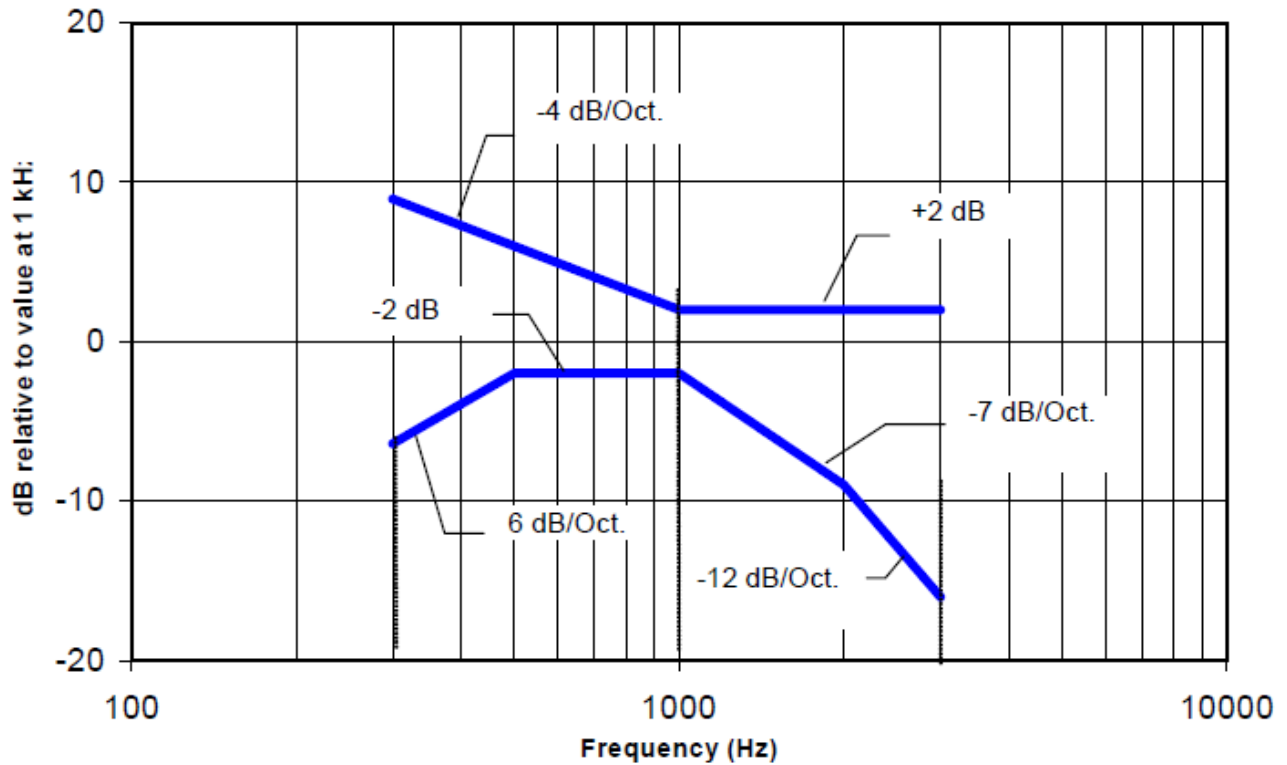

Figure 2 —Magnetic field frequency response for WDs with a field that exceeds -15dB(A/m) at 1 kHz

3) Signal quality

This part provides the signal quality requirement for the intended T-Coil signal from a WD. Only the RF immunity of the hearing aid is measured in T-Coil mode. It is assumed that a hearing aid can have no immunity to an interference signal in the audio band, which is the intended reception band for this mode. So, the only criteria that can be measured is the RF immunity in T-Coil mode. This is measured using the same procedure as for the audio coupling mode and at the same levels.

The worst signal quality of the three T-Coil signal measurements shall be used to determine the T-Coil mode category per Table 3

Category	Telephone parameters WD signal quality [(signal + noise) – to – noise ratio in decibels]
Category T1	0 dB to 10 dB
Category T2	10 dB to 20 dB
Category T3	20 dB to 30 dB
Category T4	> 30 dB

Table 3: T-Coil signal quality categories

5.2 T-Coil measurement points and reference plane

Figure 3 illustrate the references and reference plane that shall be used in a typical EUT emissions measurement. The principle of this section is applied to EUT with similar geometry. Please refer to Appendix C for the setup photographs.

- ◆ The area is 5 cm by 5 cm.
- ◆ The area is centered on the audio frequency output transducer of the EUT.
- ◆ The area is in a reference plane, which is defined as the planar area that contains the highest point in the area of the phone that normally rests against the user's ear. It is parallel to the centerline of the receiver area of the phone and is defined by the points of the receiver-end of the EUT handset, which, in normal handset use, rest against the ear.
- ◆ The measurement plane is parallel to, and 10 mm in front of, the reference plane.

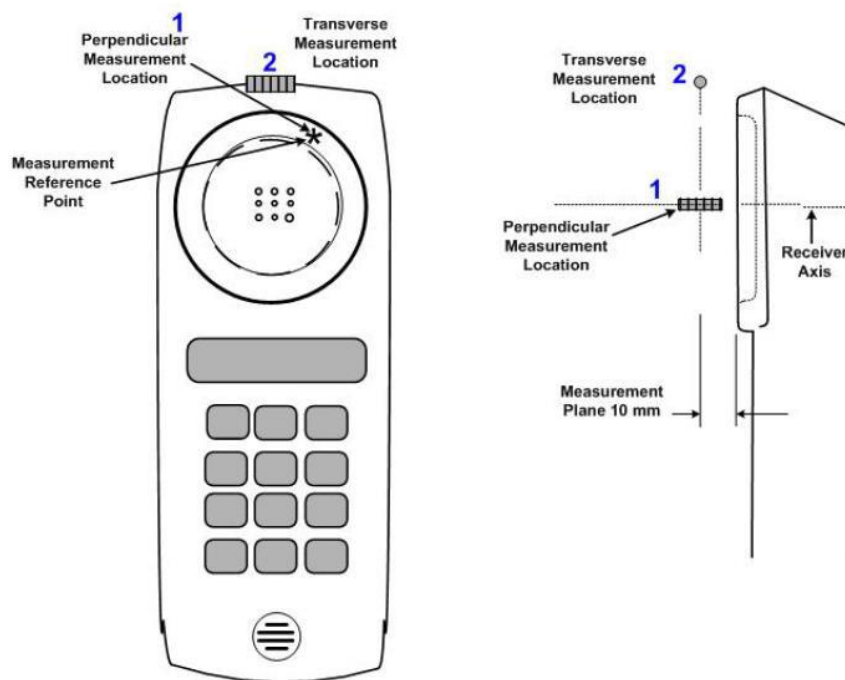

Figure 3 Axis and planes for WD audio frequency magnetic field measurements

5.3 T-Coil Measurement Procedure

According to ANSI C63.19-2011, section 7.4:

This section describes the procedures used to measure the ABM (T-Coil) performance of the WD. In addition to measuring the absolute signal levels, the A-weighted magnitude of the unintended signal shall also be determined. To assure that the required signal quality is measured, the measurement of the intended signal and the measurement of the unintended signal must be made at the same location for each measurement position. In addition, the RF field strength at each measurement location must be at or below that required for the assigned category.

Measurements shall not include undesired properties from the WD's RF field; therefore, use of a coaxial connection to a base station simulator or nonradiating load might be necessary. However, even with a coaxial connection to a base station simulator or nonradiating load, there might still be RF leakage from the WD, which can interfere with the desired measurement. Premeasurement checks should be made to avoid this possibility. All measurements shall be performed with the WD operating on battery power with an appropriate normal speech audio signal input level given in ANSI C63.19-2011 Table 7.1. If the device display can be turned off during a phone call, then that may be done during the measurement as well.

Measurements shall be performed at two locations specified in ANSI C63.19-2011 A.3, with the correct probe orientation for a particular location, in a multistage sequence by first measuring the field intensity of the desired T-Coil signal (ABM1) that is useful to a hearing aid T-Coil. The undesired magnetic components (ABM2) shall be examined for each probe orientation to determine the possible effects from the WD display and battery current paths that might disrupt the desired T-Coil signal. The undesired magnetic signal (ABM2) must be measured at the same location as the desired ABM or T-Coil signal (ABM1), and the ratio of desired to undesired ABM signals must be calculated. For the perpendicular field location, only the ABM1 frequency response shall be determined in a third measurement stage.

The following steps summarize the basic test flow for determining ABM1 and ABM2. These steps assume that a sine-wave or narrowband 1/3 octave signal can be used for the measurement of ABM1.

- a) A validation of the test setup and instrumentation may be performed using a TMFS or Helmholtz coil. Measure the emissions and confirm that they are within the specified tolerance.
- b) Position the WD in the test setup and connect the WD RF connector to a base station simulator or a nonradiating load as shown in ANSI C63.19-2011 Figure 7.1 or Figure 7.2. Confirm that the equipment that requires calibration has been calibrated and that the noise level meets the requirements of ANSI C63.19-2011 clause 7.3.1.
- c) The drive level to the WD is set such that the reference input level specified in ANSI C63.19-2011 Table 7.1 is input to the base station simulator (or manufacturer's test mode equivalent) in the 1 kHz, 1/3 octave band. This drive level shall be used for the T-Coil signal test (ABM1) at $f = 1$ kHz. Either a sine wave at 1025 Hz or a voice-like signal, band-limited to the 1 kHz 1/3 octave, as defined in C63.19-2011 clause 7.4.2, shall be used for the reference audio signal. If interference is found at 1025 Hz, an alternative nearby reference audio signal frequency may be used.⁴⁷ The same drive level shall be used for the ABM1 frequency response measurements at each 1/3 octave band center frequency. The WD volume control may be set at any level up to maximum, provided that a signal at any frequency at maximum modulation would not result in clipping or signal overload.
- d) Determine the magnetic measurement locations for the WD device (A.3), if not already specified by the manufacturer, as described in C63.19-2011 clause 7.4.4.1.1 and 7.4.4.2.
- e) At each measurement location, measure and record the desired T-Coil magnetic signals (ABM1 at f_i) as specified in C63.19-2011 clause 7.4.4.2 in each ISO 266-1975 R10 standard 1/3 octave band. The desired audio band input frequency (f_i) shall be centered in each 1/3 octave band maintaining the same drive level as determined in item c) and the reading taken for that band.
- f) Equivalent methods of determining the frequency response may also be employed, such as fast Fourier transform (FFT) analysis using noise excitation or input-output comparison using simulated speech. The full-band integrated or half-band integrated probe output, as specified in D.9, may be used, as long as the appropriate calibration curve is applied to the measured result, so as to yield an accurate measurement of the field magnitude. (The resulting measurement shall be an accurate measurement in dB A/m.)
- g) All measurements of the desired signal shall be shown to be of the desired signal and not of an undesired signal. This may be shown by turning the desired signal ON and OFF with the probe measuring the same location. If the scanning method is used, the scans shall show that all measurement points selected for the ABM1 measurement meet the ambient and test system noise criteria in C63.19-2011 clause 7.3.1.
- h) At the measurement location for each orientation, measure and record the undesired broadband audio magnetic signal (ABM2) as specified in C63.19-2011 clause 7.4.4.4 with no audio signal applied (or digital zero applied, if appropriate) using A-weighting⁴⁹ and the half-band integrator. Calculate the ratio of the desired to undesired signal strength (i.e., signal quality).
- g) Determine the category that properly classifies the signal quality, based on C63.19-2011 Table 8.5.

6 T-Coil testing for CMRS Voice

6.1 General Description

1. Codec Investigation:

For a voice service/air interface, investigate the variations of codec configurations (WB, NB bit rate) and document the parameters (ABM1, ABM2, S+N/N, frequency response) for that voice service. It is only necessary to document this for one channel/band, the following worst investigation codec would be remarked to be used for the testing for the handset.

2. Air Interface Investigation:

a. Use the worst-case codec test and document a limited set of bands/channel/bandwidths. Observe the effect of changing the band and bandwidth to ensure that there are no unexpected variations. Using the knowledge of the observed variations, it is necessary to report only a set band/channel/bandwidth for each orientation for a voice service/air interface.

b. According to the ANSI C63.19 2011 section 7.3.2, test middle channel of each frequency band for HAC testing for each orientation to determine worst HAC T-Coil rating.

6.2 UMTS Tests Results

Codec Investigation:

Band	Test Mode	Codec Setting	Test Ch./Freq.	Probe Position	ABM1 (dBA/m)	ABM2 (dBA/m)	Signal Quality (dB)	T Rating	Freq. Response Variation (dB)	Frequency Response
WCDMA Band V	AMR Voice	4.75Kbps	4182/836.4	Axial (Z)	1.60	-30.59	32.19	T4	1.78	PASS
	AMR Voice	7.95Kbps	4182/836.4	Axial (Z)	1.79	-30.46	32.25	T4	0.99	PASS
	AMR Voice	12.2Kbps	4182/836.4	Axial (Z)	1.84	-30.47	32.31	T4	1.35	PASS

Remark: According to codec investigation, the worst codec is **AMR 4.75Kbps**

Air Interface Investigation:

Band	Test Mode	Test Ch./Freq.	Probe Position	ABM1 (dBA/m)	ABM2 (dBA/m)	Signal Quality (dB)	T Rating	Freq. Response Variation (dB)	Frequency Response
WCDMA Band II	AMR Voice	9400/1900	Axial (Z)	1.61	-31.10	32.71	T4	0.57	PASS
			Transversal (Y)	-7.49	-39.68	32.19	T4	N/A	
WCDMA Band IV	AMR Voice	1412/1732.4	Axial (Z)	1.75	-31.58	33.33	T4	1.21	PASS
			Transversal (Y)	-6.61	-38.71	32.10	T4	N/A	
WCDMA Band V	AMR Voice	4182/836.4	Axial (Z)	1.60	-30.59	32.19	T4	1.78	PASS
			Transversal (Y)	-6.78	-38.44	31.66	T4	N/A	

Remark:

1. Phone Condition: Mute on; Backlight off; Max Volume
2. The detail frequency response results please refer to appendix A.



6.3 CDMATests Results

Codec Investigation:

Band	Test Mode	Codec Setting	Test Ch./Freq.	Probe Position	ABM1 (dBA/m)	ABM2 (dBA/m)	Signal Quality (dB)	T Rating	Freq. Response Variation (dB)	Frequency Response
CDMA BC0	1/8th Rate	RC1 SO68	384/836.52	Axial (Z)	1.27	-29.05	30.32	T4	1.25	PASS
	1/8th Rate	RC3 SO68	384/836.52	Axial (Z)	1.69	-30.49	32.18	T4	1.58	PASS
	1/8th Rate	RC4 SO68	384/836.52	Axial (Z)	2.09	-30.45	32.54	T4	1.46	PASS

Remark: According to codec investigation, the worst codec is **RC1 SO68**.

Air Interface Investigation:

Band	Test Mode	Test Ch./Freq.	Probe Position	ABM1 (dBA/m)	ABM2 (dBA/m)	Signal Quality (dB)	T Rating	Freq. Response Variation (dB)	Frequency Response
CDMA BC0	1xRTT, RC1 SO3, 1/8th Rate	384/836.52	Axial (Z)	1.27	-29.05	30.32	T4	1.25	PASS
			Transversal (Y)	-7.20	-35.82	28.62	T3	N/A	
CDMA BC1	1xRTT, RC1 SO3, 1/8th Rate	600/1880	Axial (Z)	1.20	-29.23	30.43	T4	1.31	PASS
			Transversal (Y)	-7.36	-36.66	29.30	T3	N/A	
CDMA BC10	1xRTT, RC1 SO3, 1/8th Rate	580/820.5	Axial (Z)	1.28	-29.76	31.04	T4	1.44	PASS
			Transversal (Y)	-6.63	-37.21	30.58	T4	N/A	

Remark:

1. Phone Condition: Mute on; Backlight off; Max Volume
2. The detail frequency response results please refer to appendix A.

7 T-Coil testing for CMRS IP Voice

7.1 VoLTE Tests Results

1. Codec Investigation:

For a voice service/air interface, investigate the variations of codec configurations (WB, NB bit rate) and document the parameters (ABM1, ABM2, S+N/N, frequency response) for that voice service. It is only necessary to document this for one channel / band, the following worst investigation codec would be remarked to be used for the testing for the handset.

2. Air Interface Investigation:

a. Use the worst-case codec test and document a limited set of bands / channel / bandwidths. Observe the effect of changing the band and bandwidth to ensure that there are no unexpected variations. Using the knowledge of the observed variations, it is necessary to report only a set band/channel/bandwidth for each orientation for a voice service/air interface and the following worst configure would be remarked to be used for the testing for the handset.

b. Select LTE FDD / TDD one frequency band to do measurement at the worst SNR position was additionally performed with varying the BWs/Modulations/RB size to verify the variation to find out worst configuration, the observed variation is very little to be within 1.5 dB which is much less than the margin from the rating threshold.

c. According to the ANSI C63.19 2011 section 7.3.2, test middle channel of each frequency band for HAC testing for each orientation to determine worst HAC T-Coil rating.

Codec Investigation:

LTE FDD

Band	Test Mode	Codec Setting	Test Ch./Freq.	Probe Position	ABM1 (dBA/m)	ABM2 (dBA/m)	Signal Quality (dB)	T Rating	Freq. Response Variation (dB)	Frequency Response
LTE Band 25	20M QPSK 1RB_0	WB AMR 6.60Kbps	26365/1882.5	Axial (Z)	1.30	-30.05	31.35	T4	2.00	PASS
	20M QPSK 1RB_0	WB AMR 23.85Kbps	26365/1882.5	Axial (Z)	1.22	-30.18	31.40	T4	0.32	PASS
	20M QPSK 1RB_0	NB AMR 4.75Kbps	26365/1882.5	Axial (Z)	0.72	-27.82	28.54	T3	0.94	PASS
	20M QPSK 1RB_0	NB AMR 12.2Kbps	26365/1882.5	Axial (Z)	1.20	-29.23	30.43	T4	0.69	PASS
LTE Band 25	20M QPSK 1RB_0	SWB EVS 9.60Kbps	26365/1882.5	Axial (Z)	1.29	-30.67	31.96	T4	0.65	PASS
	20M QPSK 1RB_0	SWB EVS 13.2Kbps	26365/1882.5	Axial (Z)	2.67	-30.67	33.34	T4	1.20	PASS
	20M QPSK 1RB_0	WB EVS 5.90Kbps	26365/1882.5	Axial (Z)	1.37	-30.97	32.34	T4	2.00	PASS
	20M QPSK 1RB_0	WB EVS 13.2Kbps	26365/1882.5	Axial (Z)	2.33	-30.99	33.32	T4	2.00	PASS
	20M QPSK 1RB_0	NB EVS 5.90Kbps	26365/1882.5	Axial (Z)	2.17	-29.76	31.93	T4	2.00	PASS
	20M QPSK 1RB_0	NB EVS 13.2Kbps	26365/1882.5	Axial (Z)	2.22	-30.72	32.94	T4	2.00	PASS

Remark: According to codec investigation, the worst codec is **NB AMR 4.75kbps**

LTE TDD

Band	Test Mode	Codec Setting	Test Ch./Freq.	Probe Position	ABM1 (dBA/m)	ABM2 (dBA/m)	Signal Quality (dB)	T Rating	Freq. Response Variation (dB)	Frequency Response
LTE Band 41	20M QPSK 1RB_0	WB AMR 6.60Kbps	40620/2593	Axial (Z)	0.68	-26.83	27.51	T3	2.00	PASS
	20M QPSK 1RB_0	WB AMR 23.85Kbps	40620/2593	Axial (Z)	1.53	-26.67	28.20	T3	0.31	PASS
	20M QPSK 1RB_0	NB AMR 4.75Kbps	40620/2593	Axial (Z)	0.82	-27.03	27.85	T3	1.11	PASS
	20M QPSK 1RB_0	NB AMR 12.2Kbps	40620/2593	Axial (Z)	1.00	-26.79	27.79	T3	1.01	PASS
LTE Band 41	20M QPSK 1RB_0	SWB EVS 9.60Kbps	40620/2593	Axial (Z)	1.56	-27.33	28.89	T3	0.84	PASS
	20M QPSK 1RB_0	SWB EVS 13.2Kbps	40620/2593	Axial (Z)	1.54	-27.38	28.92	T3	0.58	PASS
	20M QPSK 1RB_0	WB EVS 5.90Kbps	40620/2593	Axial (Z)	1.64	-27.01	28.65	T3	1.91	PASS
	20M QPSK 1RB_0	WB EVS 13.2Kbps	40620/2593	Axial (Z)	1.64	-27.57	29.21	T3	1.83	PASS
	20M QPSK 1RB_0	NB EVS 5.90Kbps	40620/2593	Axial (Z)	1.07	-27.46	28.53	T3	2.00	PASS
	20M QPSK 1RB_0	NB EVS 13.2Kbps	40620/2593	Axial (Z)	1.11	-27.76	28.87	T3	2.00	PASS

Remark: According to codec investigation, the worst codec is **WB AMR 6.60Kbps**

Air Interface Investigation:

Band	Test Mode	Test Ch./Freq.	UL-DL Configuration	Probe Position	ABM1 (dBA/m)	ABM2 (dBA/m)	Signal Quality (dB)	T Rating	Freq. Response Variation (dB)	Frequency Response
LTE Band 25	20M QPSK 1RB_0	26365/1882.5	-	Axial (Z)	0.72	-27.82	28.54	T3	0.94	PASS
	20M QPSK 1RB_50	26365/1882.5	-	Axial (Z)	1.28	-30.22	31.50	T4	1.13	PASS
	20M QPSK 1RB_99	26365/1882.5	-	Axial (Z)	1.29	-29.56	30.85	T4	1.17	PASS
	20M QPSK 50RB_0	26365/1882.5	-	Axial (Z)	1.30	-30.10	31.40	T4	1.08	PASS
	20M QPSK 50RB_25	26365/1882.5	-	Axial (Z)	1.39	-31.67	33.06	T4	0.71	PASS
	20M QPSK 50RB_50	26365/1882.5	-	Axial (Z)	0.79	-28.53	29.32	T3	0.76	PASS
	20M QPSK 100RB_0	26365/1882.5	-	Axial (Z)	0.68	-29.32	30.00	T3	0.95	PASS
	20M 16QAM 1RB_0	26365/1882.5	-	Axial (Z)	0.92	-29.26	30.18	T4	1.94	PASS
	15M QPSK 1RB_0	26365/1882.5	-	Axial (Z)	0.90	-28.33	29.23	T3	0.76	PASS
	10M QPSK 1RB_0	26365/1882.5	-	Axial (Z)	0.60	-28.05	28.65	T3	1.38	PASS
	5M QPSK 1RB_0	26365/1882.5	-	Axial (Z)	0.58	-30.72	31.30	T4	0.98	PASS
	3M QPSK 1RB_0	26365/1882.5	-	Axial (Z)	0.58	-30.60	31.18	T4	1.80	PASS
	1.4M QPSK 1RB_0	26365/1882.5	-	Axial (Z)	0.54	-31.00	31.54	T4	1.93	PASS
LTE Band 41 PC3	20M QPSK 1RB_0	40620/2593	0	Axial (Z)	0.68	-26.83	27.51	T3	2.00	PASS
	20M QPSK 1RB_50	40620/2593	0	Axial (Z)	0.64	-27.50	28.14	T3	2.00	PASS
	20M QPSK 1RB_99	40620/2593	0	Axial (Z)	0.73	-27.05	27.78	T3	2.00	PASS
	20M QPSK 50RB_0	40620/2593	0	Axial (Z)	0.86	-27.46	28.32	T3	2.00	PASS
	20M QPSK 50RB_25	40620/2593	0	Axial (Z)	0.55	-28.76	29.31	T3	2.00	PASS
	20M QPSK 50RB_50	40620/2593	0	Axial (Z)	0.81	-27.33	28.14	T3	1.79	PASS
	20M QPSK 100RB_0	40620/2593	0	Axial (Z)	0.89	-28.06	28.95	T3	2.00	PASS
	20M 16QAM 1RB_0	40620/2593	0	Axial (Z)	0.94	-27.72	28.66	T3	2.00	PASS
	15M QPSK 1RB_0	40620/2593	0	Axial (Z)	0.98	-28.19	29.17	T3	2.00	PASS
	10M QPSK 1RB_0	40620/2593	0	Axial (Z)	1.35	-26.21	27.56	T3	2.00	PASS
	5M QPSK 1RB_0	40620/2593	0	Axial (Z)	1.10	-26.47	27.57	T3	2.00	PASS
	20M QPSK 1RB_0	40620/2593	1	Axial (Z)	1.19	-26.71	27.90	T3	2.00	PASS
	20M QPSK 1RB_0	40620/2593	2	Axial (Z)	1.48	-27.15	28.63	T3	2.00	PASS
	20M QPSK 1RB_0	40620/2593	3	Axial (Z)	1.40	-29.03	30.43	T4	2.00	PASS
	20M QPSK 1RB_0	40620/2593	4	Axial (Z)	0.99	-28.87	29.86	T3	2.00	PASS
	20M QPSK 1RB_0	40620/2593	5	Axial (Z)	0.77	-28.04	28.81	T3	2.00	PASS
20M QPSK 1RB_0	40620/2593	6	Axial (Z)	1.28	-28.01	29.29	T3	2.00	PASS	
LTE Band 41 PC2	20M QPSK 1RB_0	40620/2593	1	Axial (Z)	1.07	-28.15	29.22	T3	1.89	PASS
	20M QPSK 1RB_0	40620/2593	2	Axial (Z)	5.03	-27.95	32.98	T4	2.00	PASS
	20M QPSK 1RB_0	40620/2593	3	Axial (Z)	4.40	-29.29	33.69	T4	1.83	PASS
	20M QPSK 1RB_0	40620/2593	4	Axial (Z)	5.22	-29.38	34.60	T4	1.58	PASS
	20M QPSK 1RB_0	40620/2593	5	Axial (Z)	4.16	-29.22	33.38	T4	1.88	PASS

Note:

1. LTE Band 41 PC2 is LTE Band 41 Power Class 2, LTE Band 41 PC3 is LTE Band 41 Power Class 3.



Air interface:

Band	Test Mode	Test Ch./Freq.	Probe Position	ABM1 (dBA/m)	ABM2 (dBA/m)	Signal Quality (dB)	T Rating	Freq. Response Variation (dB)	Frequency Response
LTE Band 12	10M QPSK 1RB_0	23095/707.5	Axial (Z)	0.92	-28.45	29.37	T3	0.77	PASS
			Transversal (Y)	-7.70	-34.28	26.58	T3	N/A	
LTE Band 25	20M QPSK 1RB_0	26365/1882.5	Axial (Z)	0.72	-27.82	28.54	T3	0.94	PASS
			Transversal (Y)	-7.51	-35.18	27.67	T3	N/A	
LTE Band 26	15M QPSK 1RB_0	26865/831.5	Axial (Z)	0.97	-29.38	30.35	T4	1.03	PASS
			Transversal (Y)	-7.21	-36.93	29.72	T3	N/A	
LTE Band 66	20M QPSK 1RB_0	132322/1745	Axial (Z)	1.16	-28.39	29.55	T3	1.35	PASS
			Transversal (Y)	-6.98	-36.54	29.56	T3	N/A	
LTE Band 71	20M QPSK 1RB_0	133297/680.5	Axial (Z)	0.70	-27.50	28.20	T3	1.19	PASS
			Transversal (Y)	-8.01	-37.15	29.14	T3	N/A	
LTE Band 41	20M QPSK 1RB_0	40620/2593	Axial (Z)	0.68	-26.83	27.51	T3	2.00	PASS
			Transversal (Y)	-9.84	-33.51	23.67	T3	N/A	

Remark:

1. Phone Condition: Mute on; Backlight off; Max Volume
2. The detail frequency response results please refer to appendix A.

7.2 VoWiFi Tests Results

1. Codec Investigation:

For a voice service/air interface, investigate the variations of codec configurations (WB, NB bit rate) and document the parameters (ABM1, ABM2, S+N/N, frequency response) for that voice service. It is only necessary to document this for one channel/band, the following worst investigation codec would be remarked to be used for the testing for the handset.

2. Air Interface Investigation:

a. Use the worst-case codec test and document a limited set of bands/channel/bandwidths. Observe the effect of changing the band and bandwidth to ensure that there are no unexpected variations. Using the knowledge of the observed variations, it is necessary to report only a set band/channel/bandwidth for each orientation for a voice service/air interface and the following worst configure would be remarked to be used for the testing for the handset.

b. Select WLAN 2.4GHz one frequency band to do measurement at the worst SNR position was additionally performed with varying the BWs/Modulations/data rate to verify the variation to find out worst configuration, the observed variation is very little to be within 1 dB which is much less than the margin from the rating threshold.

c. According to the ANSI C63.19 2011 section 7.3.2, test middle channel of each frequency band for HAC testing for each orientation to determine worst HAC T-Coil rating.

Codec Investigation:

Band	Test Mode	Codec Setting	Test Ch./Freq.	Probe Position	ABM1 (dBA/m)	ABM2 (dBA/m)	Signal Quality (dB)	T Rating	Freq. Response Variation (dB)	Frequency Response
WiFi 2.4G	802.11b	WB AMR 6.60Kbps	6/2437	Axial (Z)	3.74	-26.43	30.17	T4	2.00	PASS
	802.11b	WB AMR 23.85Kbps	6/2437	Axial (Z)	4.83	-29.70	34.53	T4	1.53	PASS
	802.11b	NB AMR 4.75Kbps	6/2437	Axial (Z)	4.18	-30.31	34.49	T4	0.14	PASS
	802.11b	NB AMR 12.2Kbps	6/2437	Axial (Z)	4.58	-29.65	34.23	T4	1.01	PASS
	802.11b	SWB EVS 9.60Kbps	6/2437	Axial (Z)	4.75	-27.53	32.28	T4	2.00	PASS
	802.11b	SWB EVS 128Kbps	6/2437	Axial (Z)	4.74	-28.93	33.67	T4	2.00	PASS
	802.11b	WB EVS 5.90Kbps	6/2437	Axial (Z)	3.03	-30.12	33.15	T4	1.81	PASS
	802.11b	WB EVS 13.2Kbps	6/2437	Axial (Z)	4.69	-28.79	33.48	T4	1.88	PASS
	802.11b	NB EVS 5.90Kbps	6/2437	Axial (Z)	4.42	-28.15	32.57	T4	1.02	PASS
802.11b	NB EVS 13.2Kbps	6/2437	Axial (Z)	4.70	-26.59	31.29	T4	1.39	PASS	

Remark: According to codec investigation, the worst codec is **WB AMR 6.60kbps**.



Air Interface Investigation:

Band	Test Mode	Data Rate	Test Ch./Freq.	Probe Position	ABM1 (dBA/m)	ABM2 (dBA/m)	Signal Quality (dB)	T Rating	Freq. Response Variation (dB)	Frequency Response
WiFi 2.4G	802.11b	1Mbps	6/2437	Axial (Z)	3.74	-26.43	30.17	T4	2.00	PASS
WiFi 2.4G	802.11b	11Mbps	6/2437	Axial (Z)	4.48	-27.11	31.59	T4	2.00	PASS
WiFi 2.4G	802.11g	6Mbps	6/2437	Axial (Z)	4.08	-27.57	31.65	T4	2.00	PASS
WiFi 2.4G	802.11g	54Mbps	6/2437	Axial (Z)	3.84	-27.64	31.48	T4	1.89	PASS
WiFi 2.4G	802.11n-HT20	MCS0	6/2437	Axial (Z)	3.00	-28.15	31.15	T4	2.00	PASS
WiFi 2.4G	802.11n-HT20	MCS7	6/2437	Axial (Z)	4.02	-28.89	32.91	T4	2.00	PASS

Remark: According to codec investigation, the worst codec is **802.11b 1Mbps**.

Band	Test Mode	Test Ch./Freq.	Probe Position	ABM1 (dBA/m)	ABM2 (dBA/m)	Signal Quality (dB)	T Rating	Freq. Response Variation (dB)	Frequency Response
WiFi 2.4G	802.11b	6/2437	Axial (Z)	3.74	-26.43	30.17	T4	2.00	PASS
			Transversal (Y)	-4.95	-34.36	29.41	T3	N/A	

Air interface:

Remark:

1. Phone Condition: Mute on; Backlight off; Max Volume
2. The detail frequency response results please refer to appendix A.

7.3 T-Coil testing for OTT VoIP Application

1. According to the ANSI C63.19 2011 section 7.3.2, test middle channel of each frequency band for HAC testing for each orientation to determine worst HAC T-Coil rating.
 2. The google Duo VoIP application are pre-installed on this device. According to KDB 285076 D02, all air interfaces via a data connection with VoIP application need to be considered HAC testing.
 3. The Google Duo only support OPUS audio codec and support 6Kbps to 75Kbps bitrate.
 4. The test setup used for OTT VoIP call is the DUT connect to the CMW500 and via the data application unit on CMW500 connection to the Internet, the Auxiliary EUT is connected to the WiFi access point, the channel/Modulation/Frequency bands/data rate is configured on the CMW500 for the DUT unit. For the Auxiliary VoIP unit which is used to configure the audio codec rate and determine the audio input level of -20dBm0 based on the KDB 285076 D02v03 requirement.
 5. Codec Investigation: For a voice service/air interface, investigate the variations of codec configurations (WB, NB bit rate) and document the parameters (ABM1, ABM2, S+N/N, frequency response) for that voice service. It is only necessary to document this for one channel/band, the following tests results which the worst case codec would be remarked to be used for the testing for the handset.
 6. Air Interface Investigation:
 - a. Use the worst-case codec test and document a limited set of bands/channel/bandwidths. Observe the effect of changing the band and bandwidth to ensure that there are no unexpected variations. Using the knowledge of the observed variations, it is necessary to report only a set band/channel/bandwidth for each orientation for a voice service/air interface.
 - b. Due to OTT service and CMRS IP service are all be established over the internet protocol for the voice service, and on both services use the identical RF air interface for the WIFI and LTE, therefore according to VoLTE and VoWiFi test results of air interface investigation, the worst configuration and frequency band of air interface was used for OTT T-Coil testing.
- LTE FDD worst configuration and band: LTE Band 12/10MHz/QPSK/1RB Size
-LTE TDD worst configuration and band: LTE Band 41/20MHz/QPSK/1RB Size
-WLAN2.4GHz worst configuration: 802.11b /1Mbps

Codec Investigation:
HSPA:

Band	Test Mode	Codec Setting	Test Ch./Freq.	Probe Position	ABM1 (dBA/m)	ABM2 (dBA/m)	Signal Quality (dB)	T Rating	Freq. Response Variation (dB)	Frequency Response
WCDMA Band V	HSPA	OPUS 6Kbps	4182/836.4	Axial (Z)	5.30	-28.64	33.94	T4	0.56	PASS
	HSPA	OPUS 40Kbps	4182/836.4	Axial (Z)	5.34	-28.86	34.20	T4	1.02	PASS
	HSPA	OPUS 75Kbps	4182/836.4	Axial (Z)	6.07	-29.51	35.58	T4	1.34	PASS

Remark: According to codec investigation, the worst codec bitrate is **OPUS 6Kbps**.

LTE FDD:

Band	Test Mode	Codec Setting	Test Ch./Freq.	Probe Position	ABM1 (dBA/m)	ABM2 (dBA/m)	Signal Quality (dB)	T Rating	Freq. Response Variation (dB)	Frequency Response
LTE Band 12	10M QPSK 1RB_0	OPUS 6Kbps	23095/707.5	Axial (Z)	4.34	-29.89	34.23	T4	0.89	PASS
	10M QPSK 1RB_0	OPUS 40Kbps	23095/707.5	Axial (Z)	4.12	-30.34	34.46	T4	1.07	PASS
	10M QPSK 1RB_0	OPUS 75Kbps	23095/707.5	Axial (Z)	3.96	-30.81	34.77	T4	1.08	PASS

Remark: According to codec investigation, the worst codec bitrate is **OPUS 40Kbps**.



LTE TDD:

Band	Test Mode	Codec Setting	Test Ch./Freq.	Probe Position	ABM1 (dBA/m)	ABM2 (dBA/m)	Signal Quality (dB)	T Rating	Freq. Response Variation (dB)	Frequency Response
LTE Band 41	20M QPSK 1RB_0	OPUS 6Kbps	40620/2593	Axial (Z)	5.75	-29.18	34.93	T4	2.00	PASS
	20M QPSK 1RB_0	OPUS 40Kbps	40620/2593	Axial (Z)	6.50	-28.11	34.61	T4	1.20	PASS
	20M QPSK 1RB_0	OPUS 75Kbps	40620/2593	Axial (Z)	6.70	-28.03	34.73	T4	1.28	PASS

Remark: According to codec investigation, the worst codec bitrate is **OPUS 40Kbps**.

WiFi 2.4G:

Band	Test Mode	Codec Setting	Test Ch./Freq.	Probe Position	ABM1 (dBA/m)	ABM2 (dBA/m)	Signal Quality (dB)	T Rating	Freq. Response Variation (dB)	Frequency Response
WiFi 2.4G	802.11b	OPUS 6Kbps	6/2437	Axial (Z)	4.02	-29.43	33.45	T4	0.71	PASS
	802.11b	OPUS 6Kbps	6/2437	Axial (Z)	6.60	-28.43	35.03	T4	1.28	PASS
	802.11b	OPUS 6Kbps	6/2437	Axial (Z)	6.99	-27.62	34.61	T4	1.26	PASS

Remark: According to codec investigation, the worst codec bitrate is **OPUS 6Kbps**.



Air interface:

Band	Test Mode	Test Ch./Freq.	Probe Position	ABM1 (dBA/m)	ABM2 (dBA/m)	Signal Quality (dB)	T Rating	Freq. Response Variation (dB)	Frequency Response
WCDMA Band II	HSPA	9400/1900	Axial (Z)	5.61	-30.31	35.92	T4	0.60	PASS
			Transversal (Y)	-3.13	-37.14	34.01	T4	N/A	
WCDMA Band IV	HSPA	1412/1732.4	Axial (Z)	5.38	-30.23	35.61	T4	1.05	PASS
			Transversal (Y)	-2.65	-36.19	33.54	T4	N/A	
WCDMA Band V	HSPA	4182/836.4	Axial (Z)	5.30	-28.64	33.94	T4	0.56	PASS
			Transversal (Y)	-3.46	-36.80	33.34	T4	N/A	
LTE Band 12	10M QPSK 1RB_0	23095/707.5	Axial (Z)	4.34	-29.89	34.23	T4	0.89	PASS
			Transversal (Y)	-5.21	-38.09	32.88	T4	N/A	
LTE Band 41	20M QPSK 1RB_0	40620/2593	Axial (Z)	6.50	-28.11	34.61	T4	1.20	PASS
			Transversal (Y)	-2.32	-36.03	33.71	T4	N/A	
WiFi 2.4G	802.11b	6/2437	Axial (Z)	4.02	-29.43	33.45	T4	0.71	PASS
			Transversal (Y)	-3.30	-35.20	31.90	T4	N/A	

Remark:

1. Phone Condition: Mute on; Backlight off; Max Volume
2. The detail frequency response results please refer to appendix A.

8 Equipment list

Equipment	Manufacturer	Model	Serial Number	Calibration Date	Due date of calibration
<input checked="" type="checkbox"/> Software	SPEAG	DASY52 52.8.8	NA	NCR	NCR
<input checked="" type="checkbox"/> DAE	SPEAG	DAE4	896	2019-09-18	2020-09-17
<input checked="" type="checkbox"/> Audio Magnetic 1D Field Probe	SPEAG	AM1DV3	3115	2019-06-14	2020-06-13
<input checked="" type="checkbox"/> Test Arch SD HAC	SPEAG	NA	NA	NCR	NCR
<input checked="" type="checkbox"/> Audio Magnetic Measuring Instrument	SPEAG	AMMI	1028	NCR	NCR
<input checked="" type="checkbox"/> Audio Magnetic	SPEAG	AMCC	1143	N/A	N/A
<input checked="" type="checkbox"/> Universal Radio Communication Tester	R&S	CMU200	123090	2019-06-25	2020-06-24
<input checked="" type="checkbox"/> Universal Radio Communication Tester	R&S	CMW500	103990	2019-04-09	2020-04-08
<input checked="" type="checkbox"/> Humidity and Temperature Indicator	KIMTOKA	KIMTOKA	NA	2019-04-15	2020-04-14

Note:

1. All the equipments are within the valid period when the tests are performed.
2. NCR: "No-Calibration Required".

9 Calibration certificate

Please see the Appendix B

10 Photographs

Please see the Appendix C

Appendix A: Detailed Test Results

Appendix B: Calibration certificate

Appendix C: Photographs

---END---



Appendix A

Detailed Test Results

1. WCDMA
WCDMA Band II for T-coil
WCDMA Band IV for T-coil
WCDMA Band V for T-coil
2. CDMA
CDMA BC0 for T-coil
CDMA BC1 for T-coil
CDMA BC10 for T-coil
3. LTE
LTE Band 12 for T-coil
LTE Band 25 for T-coil
LTE Band 26 for T-coil
LTE Band 66 for T-coil
LTE Band 71 for T-coil
LTE Band 41 for T-coil
4. WIFI
WIFI 2.4G for T-coil

Test Laboratory: SGS-SAR Lab

U693CL HAC-T-Coil-WCDMA Band II AMR Vioce 9400CH

DUT: U693CL; Type: Smartphone; Serial: 99001565000191

Communication System: UID 0, WCDMA (0); Frequency: 1880 MHz;Duty Cycle: 1:1

Medium: Air;Medium parameters used: $\sigma = 0$ S/m, $\epsilon_r = 1$; $\rho = 0$ kg/m³

Phantom section: TCoil Section

DASY 5 Configuration:

- Probe: AM1DV3 - 3115; ; Calibrated: 2019-06-14
- Sensor-Surface: 0mm (Fix Surface)
- Electronics: DAE4 Sn896; Calibrated: 2019-09-18
- Phantom: HAC Test Arch with AMCC; Type: SD HAC P01 BA;
- DASY52 52.8.8(1222); SEMCAD X 14.6.10(7331)

T-Coil scan/General Scans/z (axial) 4.2mm 50 x 50/ABM SNR(x,y,z) (13x13x1):

Measurement grid: dx=10mm, dy=10mm

ABM1/ABM2 = 32.71 dB

ABM1 comp = 1.61 dBA/m

BWC Factor = 0.17 dB

Location: 0, 0, 3.7 mm

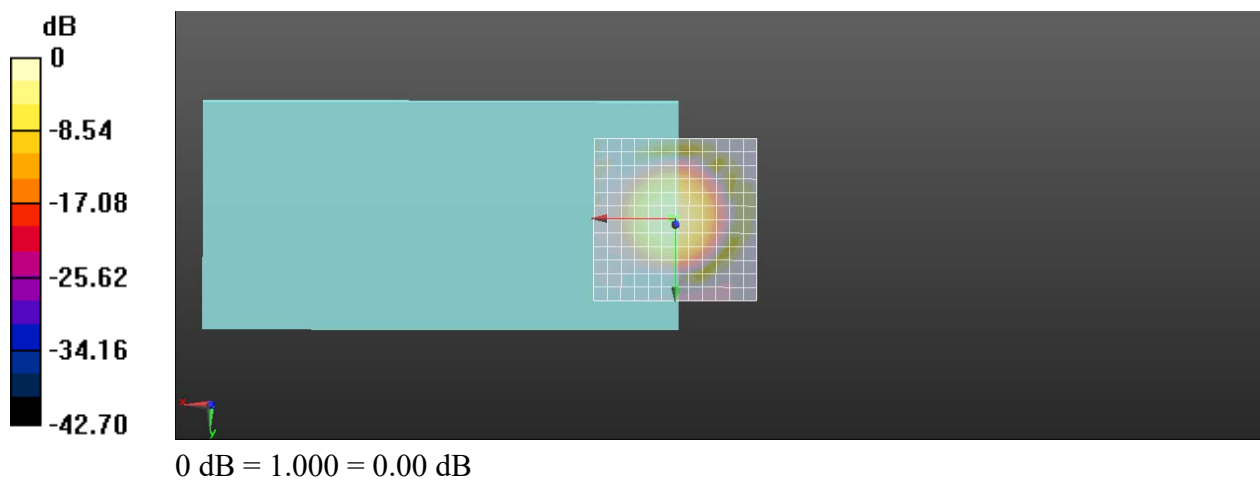

General Scans/z (axial) wideband at best S/N/ABM Freq Resp(x,y,z,f)

Loc: 1.2, -0.5, 3.7 mm Diff: 0.57dB

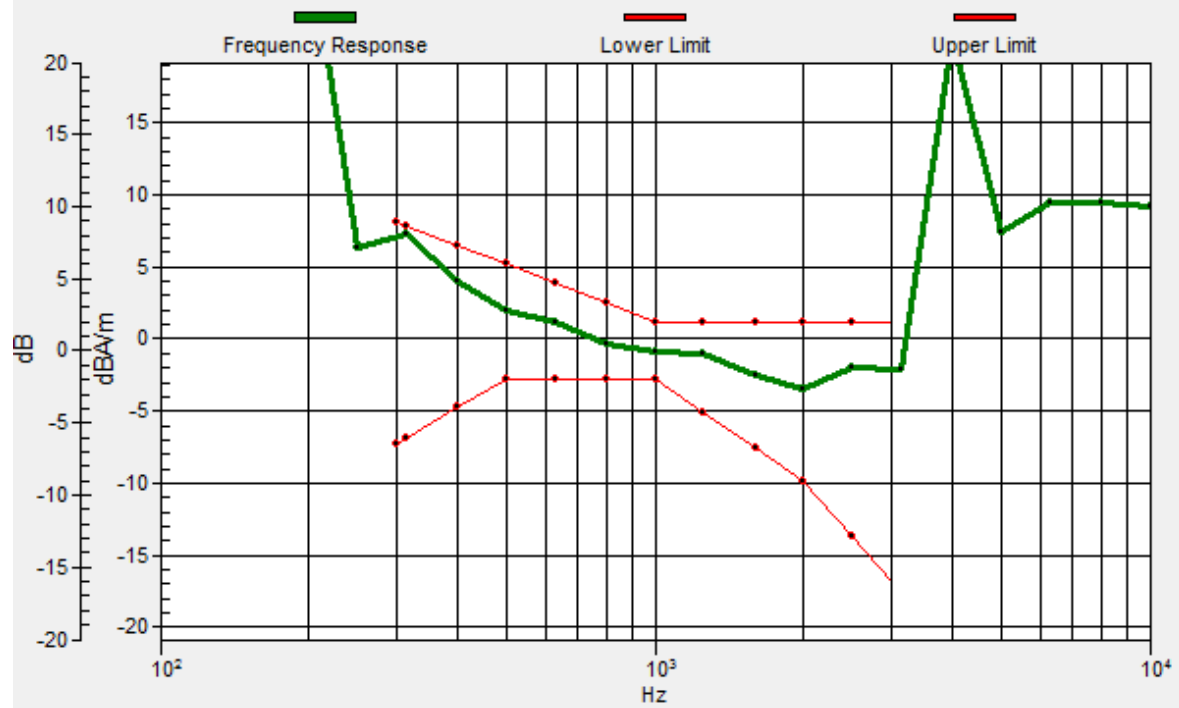

Test Laboratory: SGS-SAR Lab

U693CL HAC-T-Coil-WCDMA Band II AMR Vioce 9400CH

DUT: U693CL; Type: Smartphone; Serial: 99001565000191

Communication System: UID 0, WCDMA (0); Frequency: 1880 MHz;Duty Cycle: 1:1

Medium: Air;Medium parameters used: $\sigma = 0$ S/m, $\epsilon_r = 1$; $\rho = 0$ kg/m³

Phantom section: TCoil Section

DASY 5 Configuration:

- Probe: AM1DV3 - 3115; ; Calibrated: 2019-06-14
- Sensor-Surface: 0mm (Fix Surface)
- Electronics: DAE4 Sn896; Calibrated: 2019-09-18
- Phantom: HAC Test Arch with AMCC; Type: SD HAC P01 BA;
- DASY52 52.8.8(1222); SEMCAD X 14.6.10(7331)

T-Coil scan/General Scans/y (transversal) 4.2mm 50 x 50/ABM SNR(x,y,z)

(13x13x1): Measurement grid: dx=10mm, dy=10mm

ABM1/ABM2 = 32.19 dB

ABM1 comp = -7.49 dBA/m

BWC Factor = 0.17 dB

Location: 0, -8.3, 3.7 mm

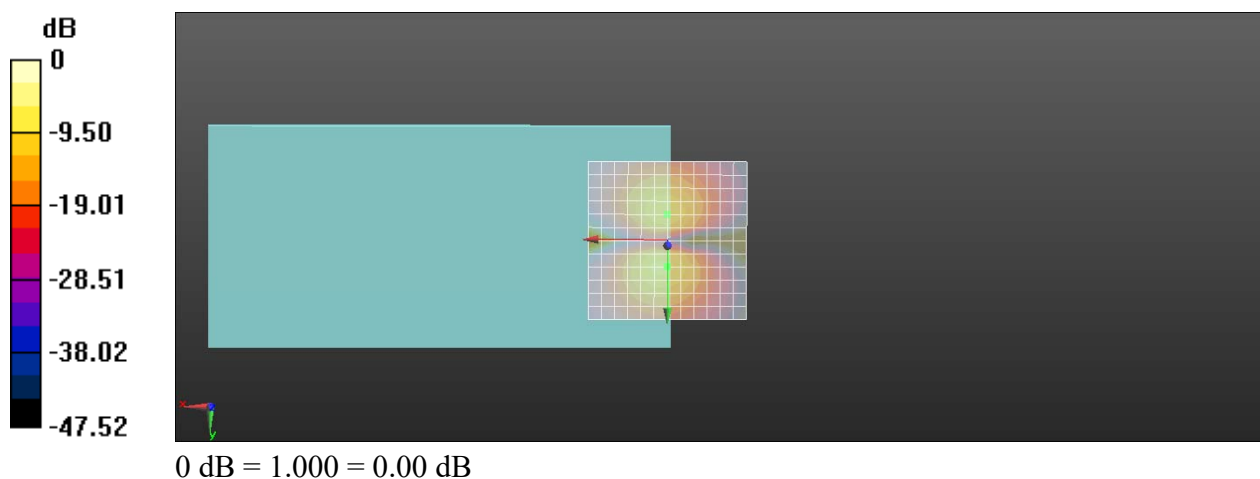

Test Laboratory: SGS-SAR Lab

U693CL HAC-T-Coil-WCDMA Band II HSPA 9400CH

DUT: U693CL; Type: Smartphone; Serial: 99001565000191

Communication System: UID 0, WCDMA (0); Frequency: 1880 MHz; Duty Cycle: 1:1

Medium: Air; Medium parameters used: $\sigma = 0$ S/m, $\epsilon_r = 1$; $\rho = 0$ kg/m³
Phantom section: TCoil Section

DASY 5 Configuration:

- Probe: AM1DV3 - 3115; ; Calibrated: 2019-06-14
- Sensor-Surface: 0mm (Fix Surface)
- Electronics: DAE4 Sn896; Calibrated: 2019-09-18
- Phantom: HAC Test Arch with AMCC; Type: SD HAC P01 BA;
- DASY52 52.8.8(1222); SEMCAD X 14.6.10(7331)

T-Coil scan/General Scans/z (axial) 4.2mm 50 x 50/ABM SNR(x,y,z) (13x13x1):

Measurement grid: dx=10mm, dy=10mm

ABM1/ABM2 = 35.92 dB

ABM1 comp = 5.61 dBA/m

BWC Factor = 0.16 dB

Location: 0, 0, 3.7 mm

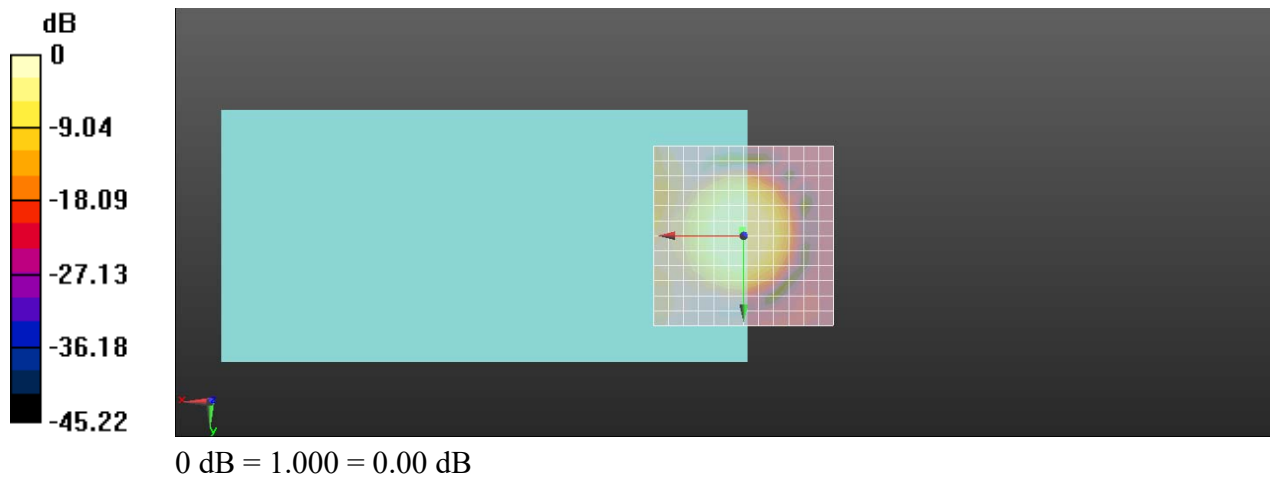

General Scans/z (axial) wideband at best S/N/ABM Freq Resp(x,y,z,f)

Loc: 0.4, -1.5, 3.7 mm Diff: 0.6dB

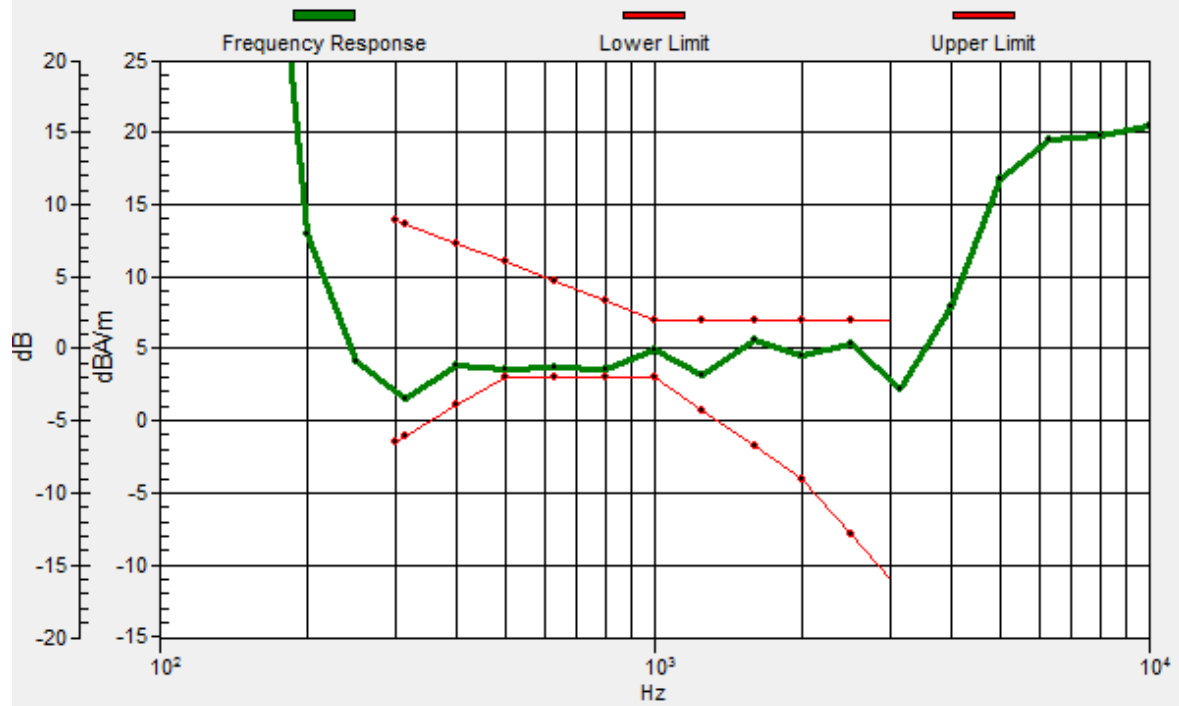

Test Laboratory: SGS-SAR Lab

U693CL HAC-T-Coil-WCDMA Band II HSPA 9400CH

DUT: U693CL; Type: Smartphone; Serial: 99001565000191

Communication System: UID 0, WCDMA (0); Frequency: 1880 MHz; Duty Cycle: 1:1

Medium: Air; Medium parameters used: $\sigma = 0$ S/m, $\epsilon_r = 1$; $\rho = 0$ kg/m³

Phantom section: TCoil Section

DASY 5 Configuration:

- Probe: AM1DV3 - 3115; ; Calibrated: 2019-06-14
- Sensor-Surface: 0mm (Fix Surface)
- Electronics: DAE4 Sn896; Calibrated: 2019-09-18
- Phantom: HAC Test Arch with AMCC; Type: SD HAC P01 BA; Serial:
- DASY52 52.8.8(1222); SEMCAD X 14.6.10(7331)

T-Coil scan/General Scans/y (transversal) 4.2mm 50 x 50/ABM SNR(x,y,z)

(13x13x1): Measurement grid: dx=10mm, dy=10mm

ABM1/ABM2 = 34.01 dB

ABM1 comp = -3.13 dBA/m

BWC Factor = 0.16 dB

Location: 0, -8.3, 3.7 mm

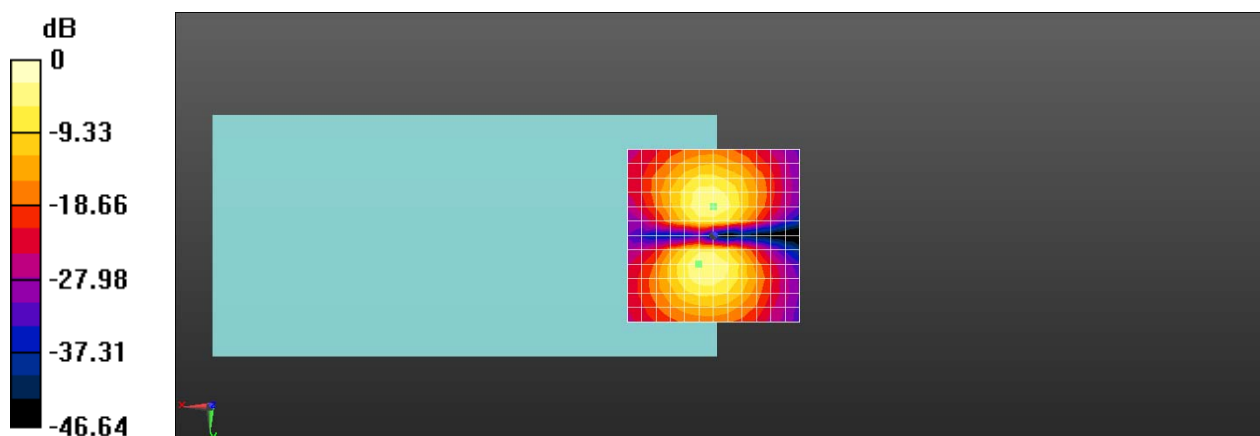

0 dB = 1.000 = 0.00 dB

Test Laboratory: SGS-SAR Lab

U693CL HAC-T-Coil-WCDMA Band IV AMR Vioce 1412CH

DUT: U693CL; Type: Smartphone; Serial: 99001565000191

Communication System: UID 0, WCDMA (0); Frequency: 1732.4 MHz; Duty Cycle: 1:1

Medium: Air; Medium parameters used: $\sigma = 0$ S/m, $\epsilon_r = 1$; $\rho = 0$ kg/m³
Phantom section: TCoil Section

DASY 5 Configuration:

- Probe: AM1DV3 - 3115; ; Calibrated: 2019-06-14
- Sensor-Surface: 0mm (Fix Surface)
- Electronics: DAE4 Sn896; Calibrated: 2019-09-18
- Phantom: HAC Test Arch with AMCC; Type: SD HAC P01 BA;
- DASY52 52.8.8(1222); SEMCAD X 14.6.10(7331)

T-Coil scan/General Scans/z (axial) 4.2mm 50 x 50/ABM SNR(x,y,z) (13x13x1):

Measurement grid: dx=10mm, dy=10mm

ABM1/ABM2 = 33.33 dB

ABM1 comp = 1.75 dBA/m

BWC Factor = 0.17 dB

Location: 0, 0, 3.7 mm

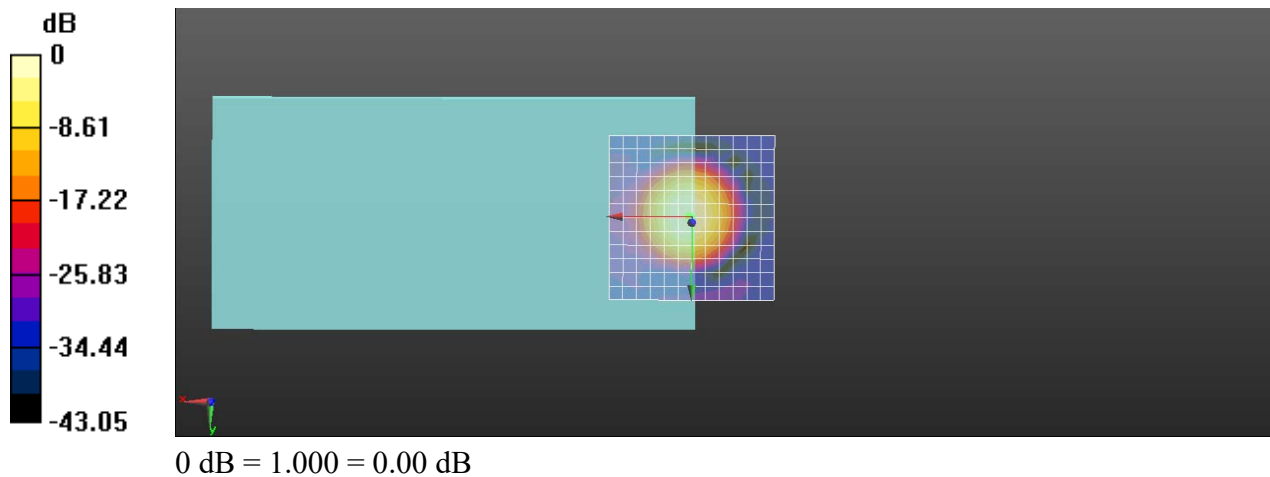

General Scans/z (axial) wideband at best S/N/ABM Freq Resp(x,y,z,f)

Loc: 0.9, -0.5, 3.7 mm Diff: 1.21dB

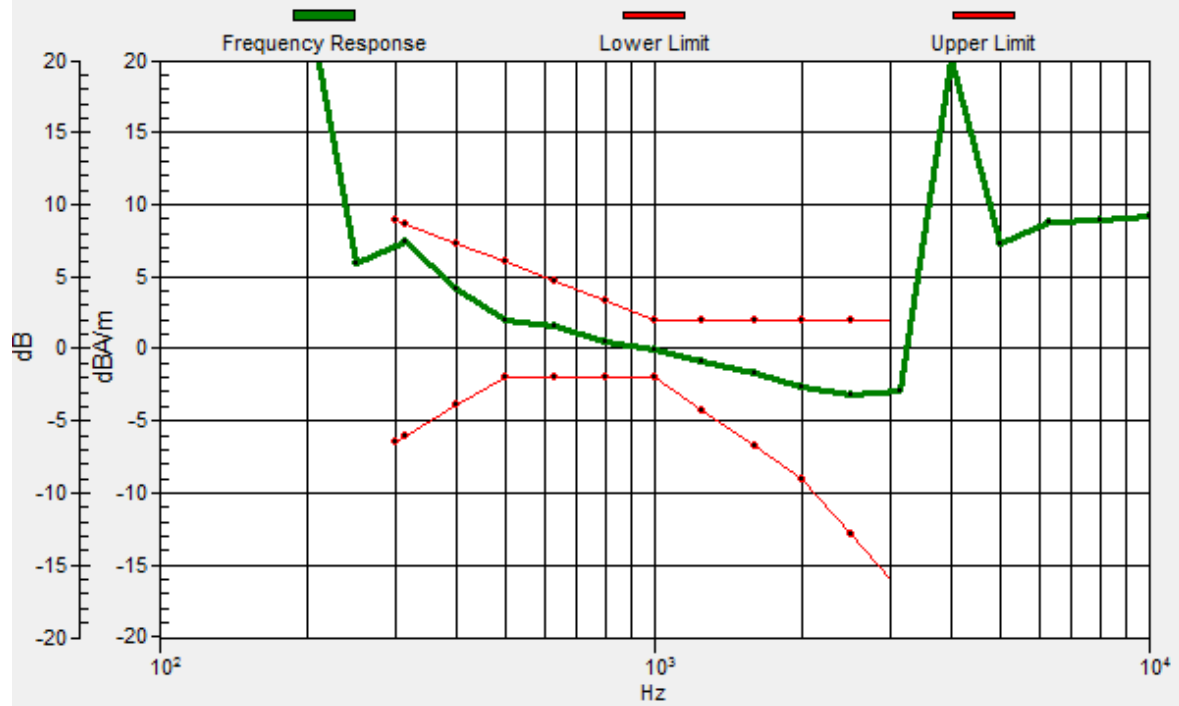

Test Laboratory: SGS-SAR Lab

U693CL HAC-T-Coil-WCDMA Band IV AMR Vioce 1412CH

DUT: U693CL; Type: Smartphone; Serial: 99001565000191

Communication System: UID 0, WCDMA (0); Frequency: 1732.4 MHz; Duty Cycle: 1:1

Medium: Air; Medium parameters used: $\sigma = 0$ S/m, $\epsilon_r = 1$; $\rho = 0$ kg/m³
Phantom section: TCoil Section

DASY 5 Configuration:

- Probe: AM1DV3 - 3115; ; Calibrated: 2019-06-14
- Sensor-Surface: 0mm (Fix Surface)
- Electronics: DAE4 Sn896; Calibrated: 2019-09-18
- Phantom: HAC Test Arch with AMCC; Type: SD HAC P01 BA;
- DASY52 52.8.8(1222); SEMCAD X 14.6.10(7331)

T-Coil scan/General Scans/y (transversal) 4.2mm 50 x 50/ABM SNR(x,y,z)

(13x13x1): Measurement grid: dx=10mm, dy=10mm

ABM1/ABM2 = 32.10 dB

ABM1 comp = -6.61 dBA/m

BWC Factor = 0.17 dB

Location: 0, 8.3, 3.7 mm

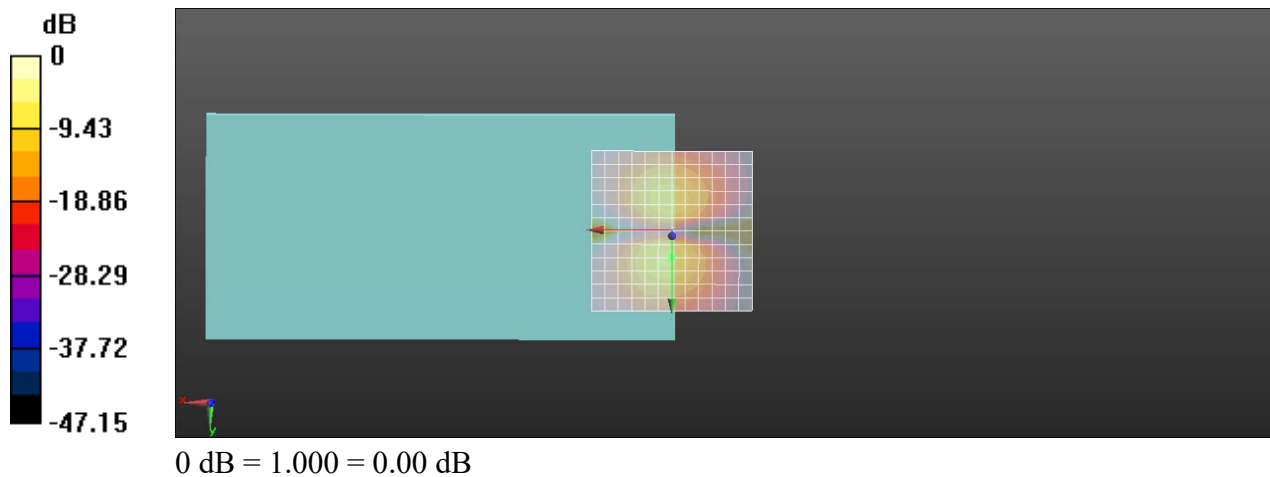

Test Laboratory: SGS-SAR Lab

U693CL HAC-T-Coil-WCDMA Band IV HSPA 1412CH

DUT: U693CL; Type: Smartphone; Serial: 99001565000191

Communication System: UID 0, WCDMA (0); Frequency: 1732.4 MHz; Duty Cycle: 1:1

Medium: Air; Medium parameters used: $\sigma = 0$ S/m, $\epsilon_r = 1$; $\rho = 0$ kg/m³

Phantom section: TCoil Section

DASY 5 Configuration:

- Probe: AM1DV3 - 3115; ; Calibrated: 2019-06-14
- Sensor-Surface: 0mm (Fix Surface)
- Electronics: DAE4 Sn896; Calibrated: 2019-09-18
- Phantom: HAC Test Arch with AMCC; Type: SD HAC P01 BA;
- DASY52 52.8.8(1222); SEMCAD X 14.6.10(7331)

T-Coil scan/General Scans/z (axial) 4.2mm 50 x 50/ABM SNR(x,y,z) (13x13x1):

Measurement grid: dx=10mm, dy=10mm

ABM1/ABM2 = 35.61 dB

ABM1 comp = 5.38 dBA/m

BWC Factor = 0.17 dB

Location: 0, 0, 3.7 mm

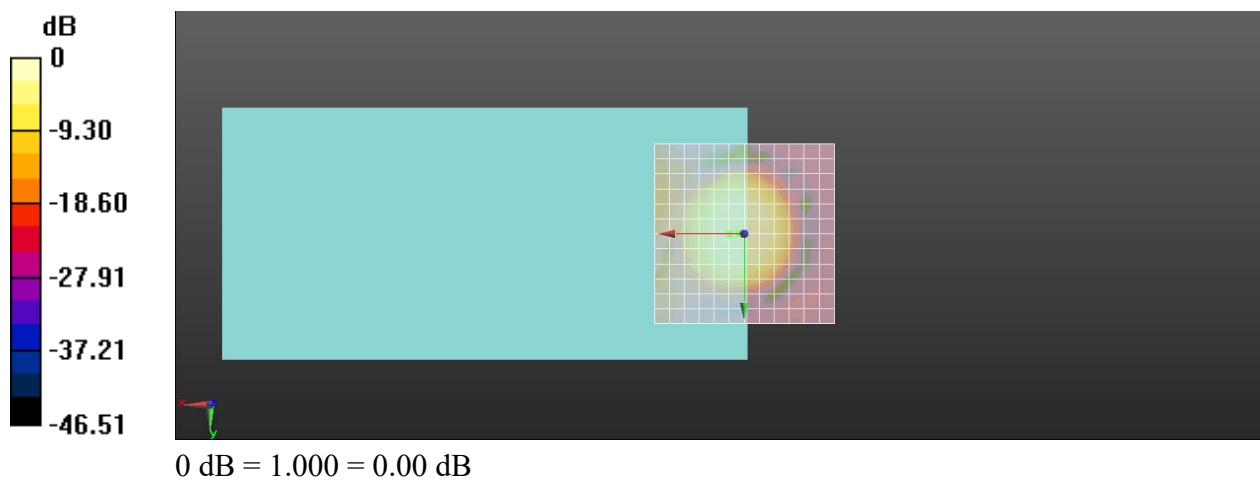

General Scans/z (axial) wideband at best S/N/ABM Freq Resp(x,y,z,f)

Loc: 1.5, -0.2, 3.7 mm Diff: 1.05dB

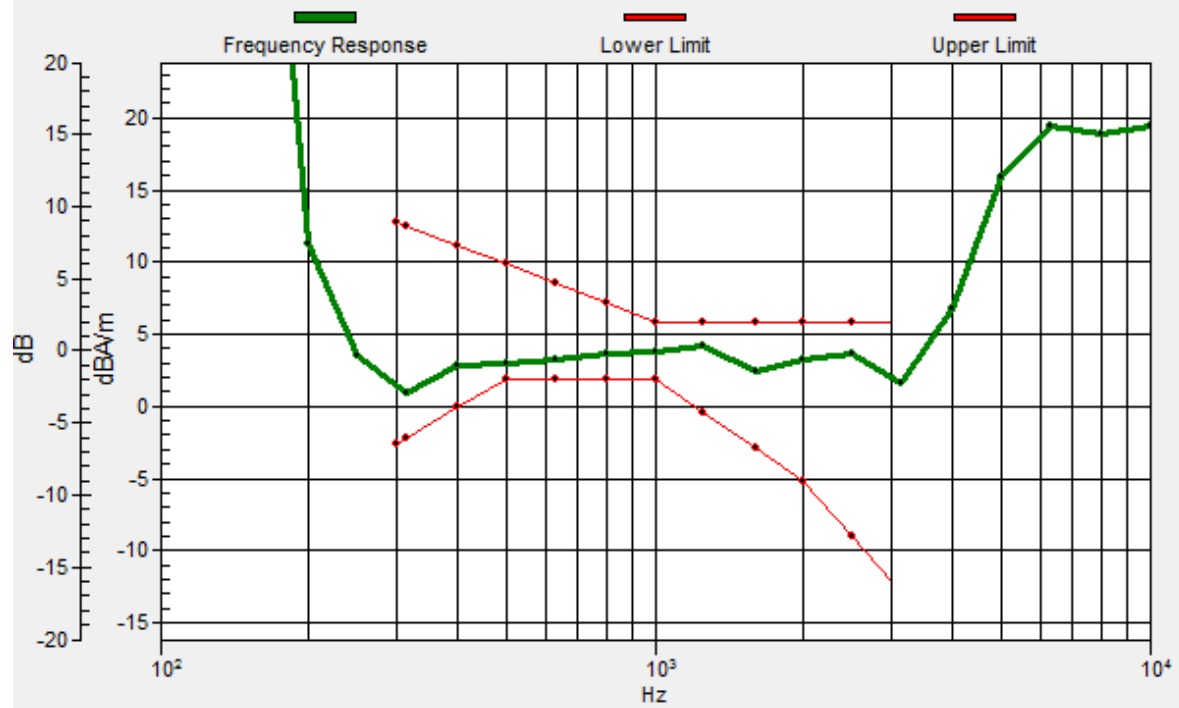

Test Laboratory: SGS-SAR Lab

U693CL HAC-T-Coil-WCDMA Band IV HSPA 1412CH

DUT: U693CL; Type: Smartphone; Serial: 99001565000191

Communication System: UID 0, WCDMA (0); Frequency: 1732.4 MHz; Duty Cycle: 1:1

Medium: Air; Medium parameters used: $\sigma = 0$ S/m, $\epsilon_r = 1$; $\rho = 0$ kg/m³

Phantom section: TCoil Section

DASY 5 Configuration:

- Probe: AM1DV3 - 3115; ; Calibrated: 2019-06-14
- Sensor-Surface: 0mm (Fix Surface)
- Electronics: DAE4 Sn896; Calibrated: 2019-09-18
- Phantom: HAC Test Arch with AMCC; Type: SD HAC P01 BA;
- DASY52 52.8.8(1222); SEMCAD X 14.6.10(7331)

T-Coil scan/General Scans/y (transversal) 4.2mm 50 x 50/ABM SNR(x,y,z)

(13x13x1): Measurement grid: dx=10mm, dy=10mm

ABM1/ABM2 = 33.54 dB

ABM1 comp = -2.65 dBA/m

BWC Factor = 0.17 dB

Location: 0, -8.3, 3.7 mm

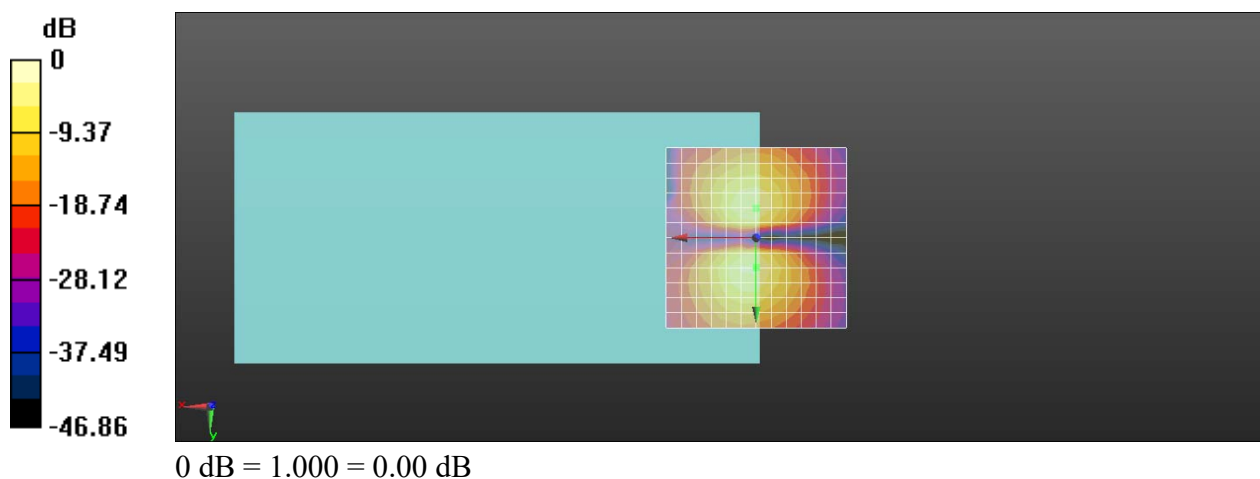

Test Laboratory: SGS-SAR Lab

U693CL HAC-T-Coil-WCDMA Band V AMR Vioce 4182CH

DUT: U693CL; Type: Smartphone; Serial: 99001565000191

Communication System: UID 0, WCDMA (0); Frequency: 836.4 MHz; Duty Cycle: 1:1

Medium: Air; Medium parameters used: $\sigma = 0$ S/m, $\epsilon_r = 1$; $\rho = 0$ kg/m³

Phantom section: TCoil Section

DASY 5 Configuration:

- Probe: AM1DV3 - 3115; ; Calibrated: 2019-06-14
- Sensor-Surface: 0mm (Fix Surface)
- Electronics: DAE4 Sn896; Calibrated: 2019-09-18
- Phantom: HAC Test Arch with AMCC; Type: SD HAC P01 BA;
- DASY52 52.8.8(1222); SEMCAD X 14.6.10(7331)

T-Coil scan/General Scans/z (axial) 4.2mm 50 x 50/ABM SNR(x,y,z) (13x13x1):

Measurement grid: dx=10mm, dy=10mm

ABM1/ABM2 = 32.19 dB

ABM1 comp = 1.60 dBA/m

BWC Factor = 0.17 dB

Location: 0, 0, 3.7 mm

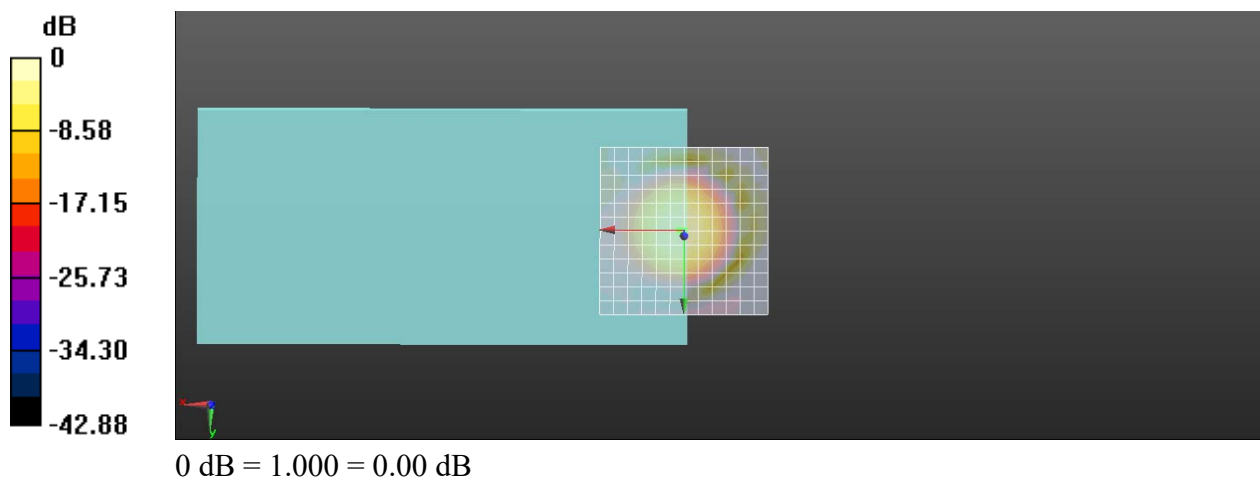

General Scans/z (axial) wideband at best S/N/ABM Freq Resp(x,y,z,f)

Loc: 1.4, -0.2, 3.7 mm Diff: 1.78dB

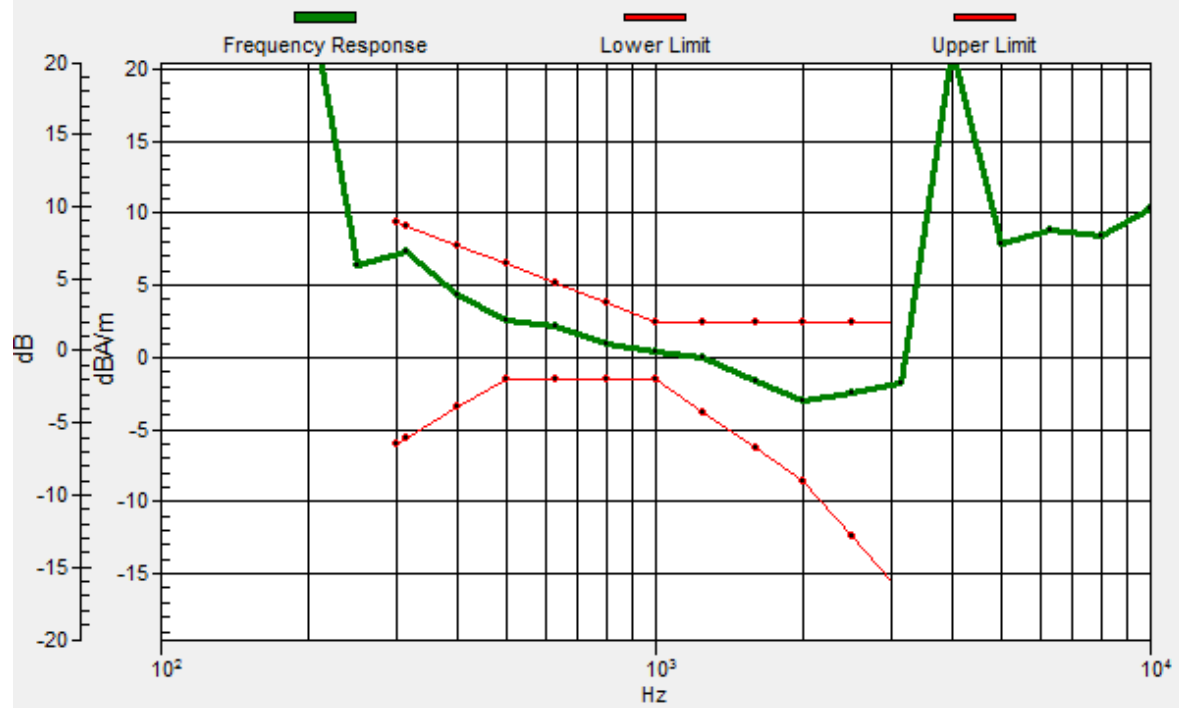

Test Laboratory: SGS-SAR Lab

U693CL HAC-T-Coil-WCDMA Band V AMR Vioce 4182CH

DUT: U693CL; Type: Smartphone; Serial: 99001565000191

Communication System: UID 0, WCDMA (0); Frequency: 836.4 MHz; Duty Cycle: 1:1

Medium: Air; Medium parameters used: $\sigma = 0$ S/m, $\epsilon_r = 1$; $\rho = 0$ kg/m³

Phantom section: TCoil Section

DASY 5 Configuration:

- Probe: AM1DV3 - 3115; ; Calibrated: 2019-06-14
- Sensor-Surface: 0mm (Fix Surface)
- Electronics: DAE4 Sn896; Calibrated: 2019-09-18
- Phantom: HAC Test Arch with AMCC; Type: SD HAC P01 BA;
- DASY52 52.8.8(1222); SEMCAD X 14.6.10(7331)

T-Coil scan/General Scans/y (transversal) 4.2mm 50 x 50/ABM SNR(x,y,z)

(13x13x1): Measurement grid: dx=10mm, dy=10mm

ABM1/ABM2 = 31.66 dB

ABM1 comp = -6.78 dBA/m

BWC Factor = 0.17 dB

Location: 0, 8.3, 3.7 mm

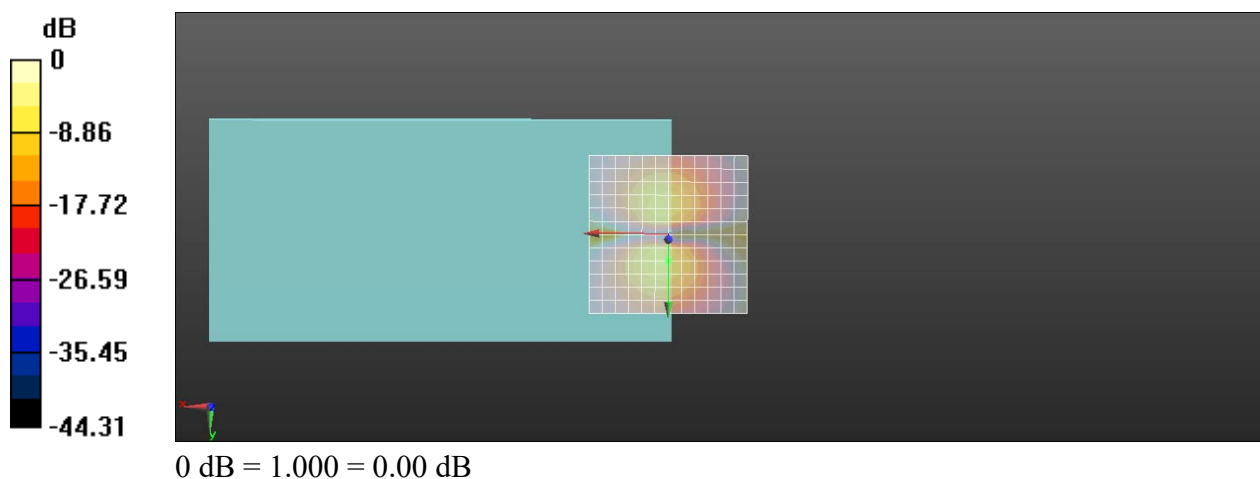

Test Laboratory: SGS-SAR Lab

U693CL HAC-T-Coil-WCDMA Band V HSPA 4182CH

DUT: U693CL; Type: Smartphone; Serial: 99001565000191

Communication System: UID 0, WCDMA (0); Frequency: 836.4 MHz; Duty Cycle: 1:1

Medium: Air; Medium parameters used: $\sigma = 0$ S/m, $\epsilon_r = 1$; $\rho = 0$ kg/m³

Phantom section: TCoil Section

DASY 5 Configuration:

- Probe: AM1DV3 - 3115; ; Calibrated: 2019-06-14
- Sensor-Surface: 0mm (Fix Surface)
- Electronics: DAE4 Sn896; Calibrated: 2019-09-18
- Phantom: HAC Test Arch with AMCC; Type: SD HAC P01 BA;
- DASY52 52.8.8(1222); SEMCAD X 14.6.10(7331)

T-Coil scan/General Scans/z (axial) 4.2mm 50 x 50/ABM SNR(x,y,z) (13x13x1):

Measurement grid: dx=10mm, dy=10mm

ABM1/ABM2 = 33.94 dB

ABM1 comp = 5.30 dBA/m

BWC Factor = 0.16 dB

Location: 0, 0, 3.7 mm

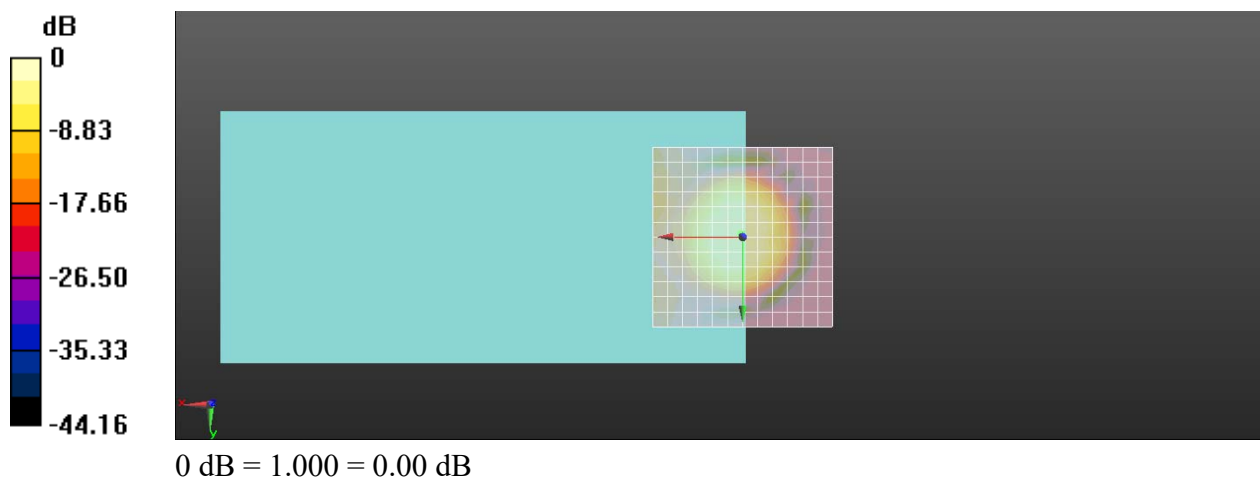

General Scans/z (axial) wideband at best S/N/ABM Freq Resp(x,y,z,f)

Loc: 0.3, -0.8, 3.7 mm Diff: 0.56dB

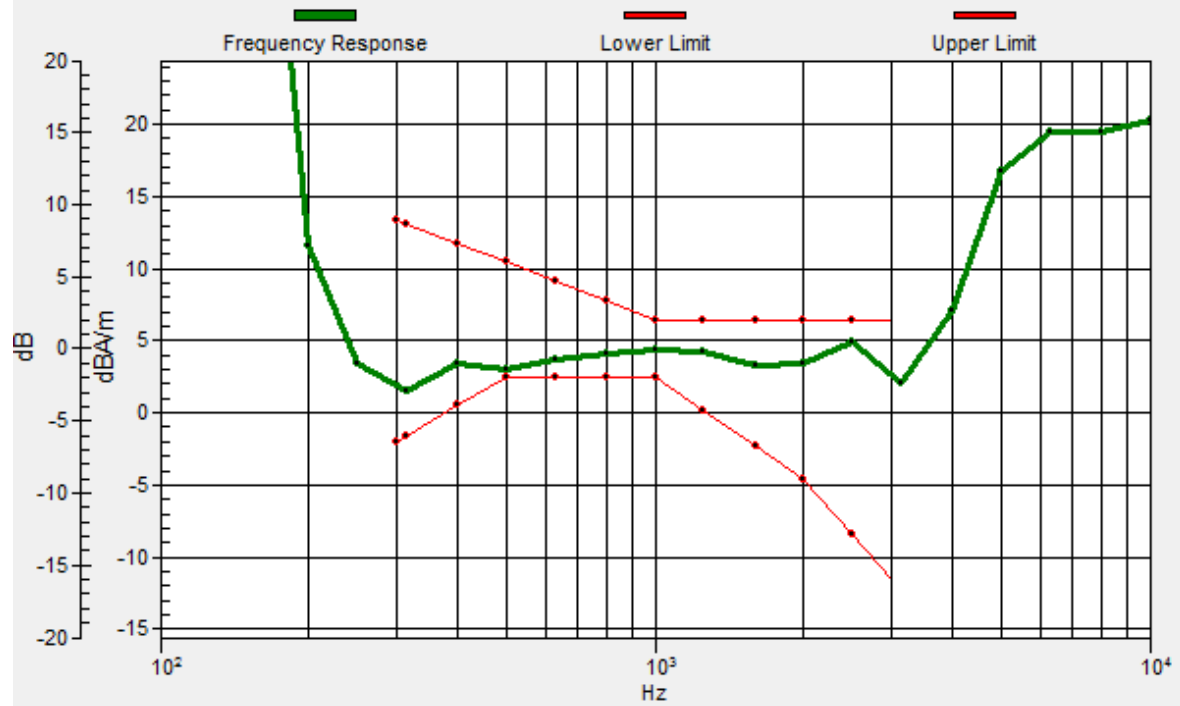

Test Laboratory: SGS-SAR Lab

U693CL HAC-T-Coil-WCDMA Band V HSPA 4182CH

DUT: U693CL; Type: Smartphone; Serial: 99001565000191

Communication System: UID 0, WCDMA (0); Frequency: 836.4 MHz; Duty Cycle: 1:1

Medium: Air; Medium parameters used: $\sigma = 0$ S/m, $\epsilon_r = 1$; $\rho = 0$ kg/m³
Phantom section: TCoil Section

DASY 5 Configuration:

- Probe: AM1DV3 - 3115; ; Calibrated: 2019-06-14
- Sensor-Surface: 0mm (Fix Surface)
- Electronics: DAE4 Sn896; Calibrated: 2019-09-18
- Phantom: HAC Test Arch with AMCC; Type: SD HAC P01 BA;
- DASY52 52.8.8(1222); SEMCAD X 14.6.10(7331)

T-Coil scan/General Scans/y (transversal) 4.2mm 50 x 50/ABM SNR(x,y,z)

(13x13x1): Measurement grid: dx=10mm, dy=10mm

ABM1/ABM2 = 33.34 dB

ABM1 comp = -3.46 dBA/m

BWC Factor = 0.16 dB

Location: 0, -8.3, 3.7 mm

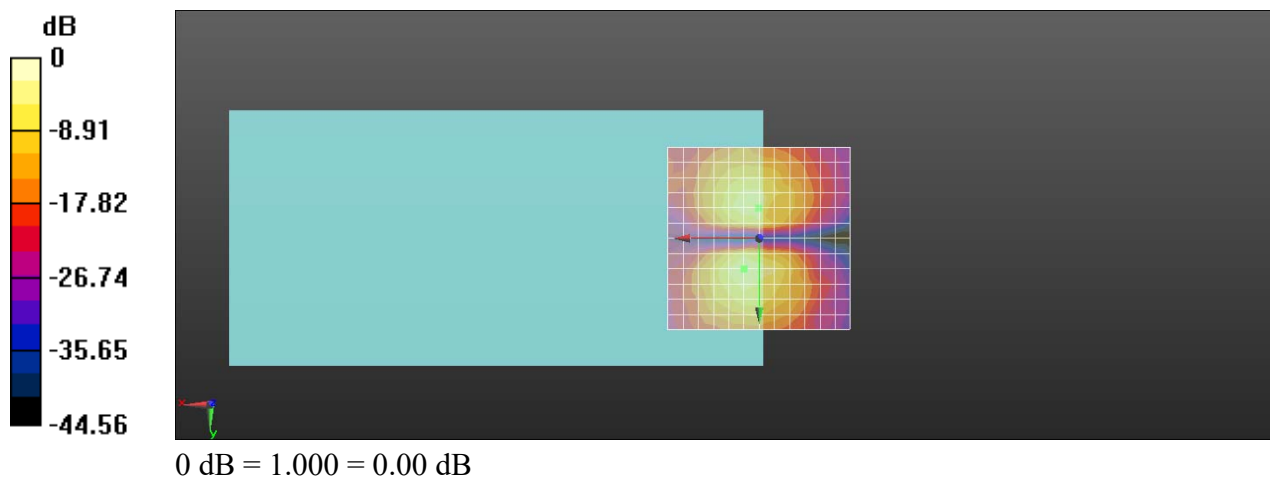

Test Laboratory: SGS-SAR Lab

U693CL HAC-T-Coil-CDMA BC0 384CH

DUT: U693CL; Type: Smartphone; Serial: 99001565000191

Communication System: UID 0, CDMA (0); Frequency: 836.52 MHz; Duty Cycle: 1:1

Medium: Air; Medium parameters used: $\sigma = 0$ S/m, $\epsilon_r = 1$; $\rho = 0$ kg/m³

Phantom section: TCoil Section

DASY 5 Configuration:

- Probe: AM1DV3 - 3115; ; Calibrated: 2019-06-14
- Sensor-Surface: 0mm (Fix Surface)
- Electronics: DAE4 Sn896; Calibrated: 2019-09-18
- Phantom: HAC Test Arch with AMCC; Type: SD HAC P01 BA;
- DASY52 52.8.8(1222); SEMCAD X 14.6.10(7331)

T-Coil scan/General Scans/z (axial) 4.2mm 50 x 50/ABM SNR(x,y,z) (13x13x1):

Measurement grid: dx=10mm, dy=10mm

ABM1/ABM2 = 30.32 dB

ABM1 comp = 1.27 dBA/m

BWC Factor = 0.16 dB

Location: 0, 0, 3.7 mm

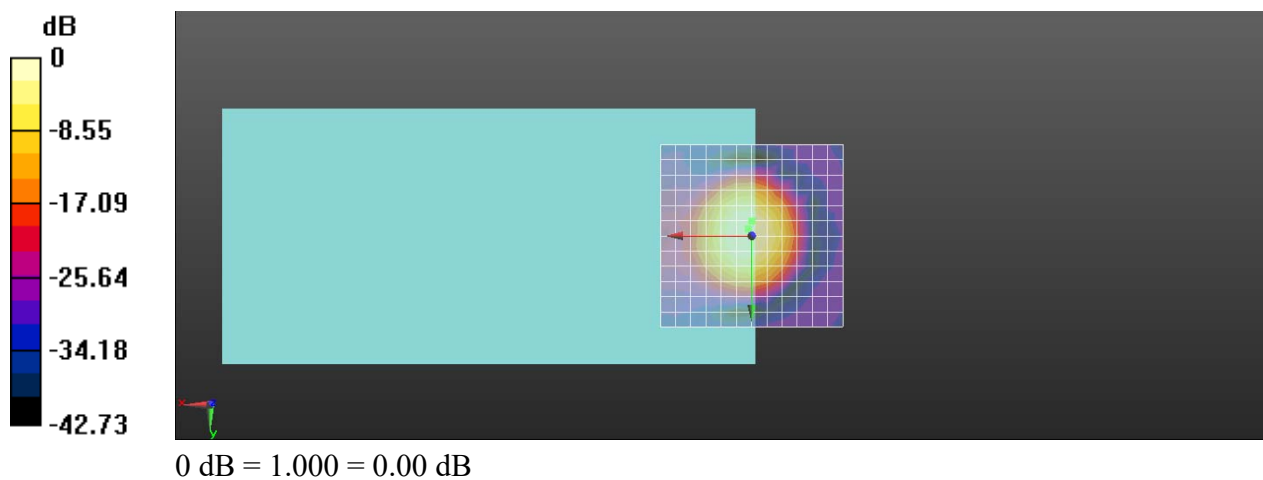

General Scans/z (axial) wideband at best S/N/ABM Freq Resp(x,y,z,f)

Loc: 0.8, -2, 3.7 mm Diff: 1.25dB

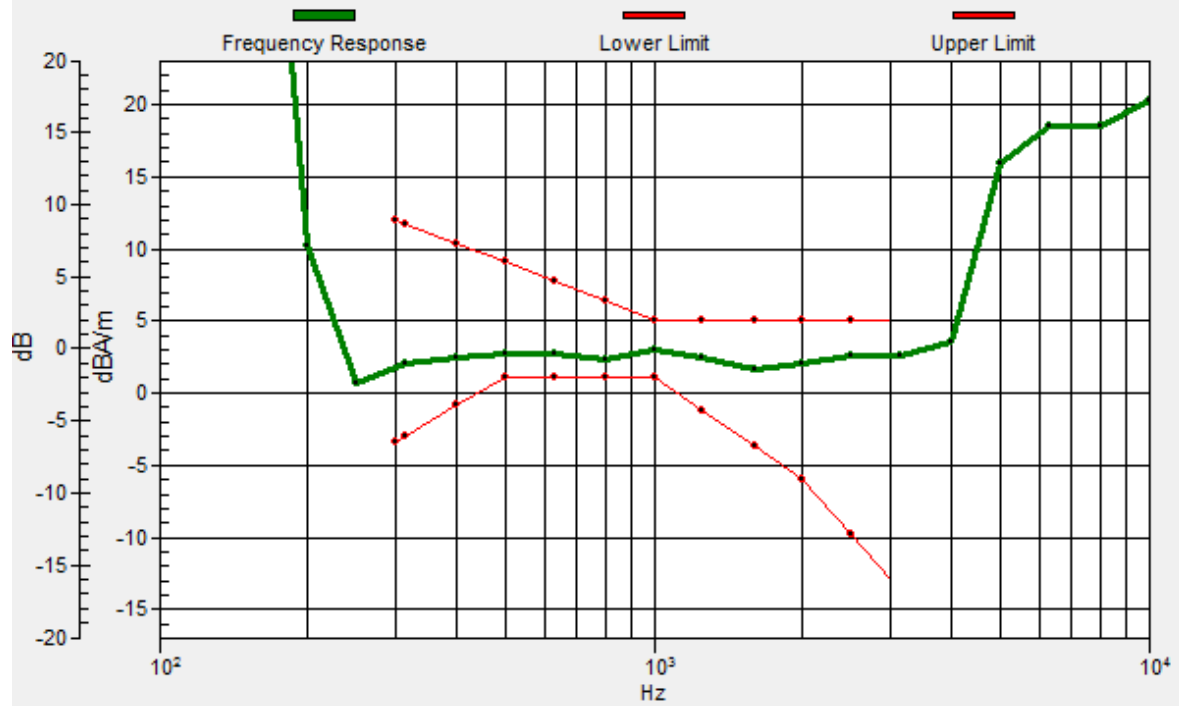

Test Laboratory: SGS-SAR Lab

U693CL HAC-T-Coil-CDMA BC0 384CH

DUT: U693CL; Type: Smartphone; Serial: 99001565000191

Communication System: UID 0, CDMA (0); Frequency: 836.52 MHz; Duty Cycle: 1:1

Medium: Air; Medium parameters used: $\sigma = 0$ S/m, $\epsilon_r = 1$; $\rho = 0$ kg/m³
Phantom section: TCoil Section

DASY 5 Configuration:

- Probe: AM1DV3 - 3115; ; Calibrated: 2019-06-14
- Sensor-Surface: 0mm (Fix Surface)
- Electronics: DAE4 Sn896; Calibrated: 2019-09-18
- Phantom: HAC Test Arch with AMCC; Type: SD HAC P01 BA;
- DASY52 52.8.8(1222); SEMCAD X 14.6.10(7331)

T-Coil scan/General Scans/y (transversal) 4.2mm 50 x 50/ABM SNR(x,y,z)

(13x13x1): Measurement grid: dx=10mm, dy=10mm

ABM1/ABM2 = 28.62 dB

ABM1 comp = -7.20 dBA/m

BWC Factor = 0.16 dB

Location: 0, -8.3, 3.7 mm

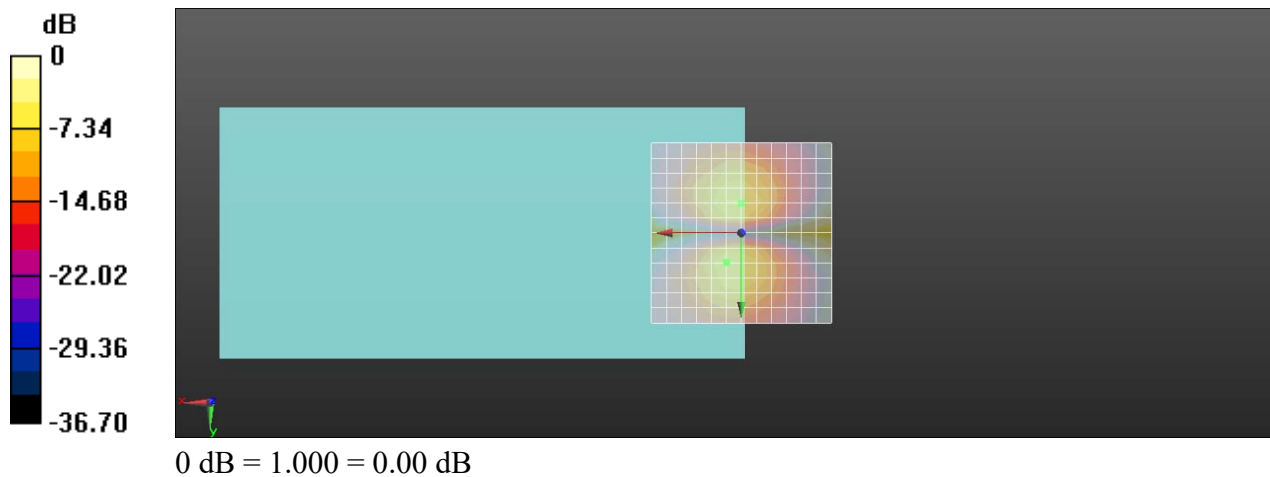

Test Laboratory: SGS-SAR Lab

U693CL HAC-T-Coil-CDMA BC1 600CH

DUT: U693CL; Type: Smartphone; Serial: 99001565000191

Communication System: UID 0, CDMA (0); Frequency: 1880 MHz; Duty Cycle: 1:1

Medium: Air; Medium parameters used: $\sigma = 0$ S/m, $\epsilon_r = 1$; $\rho = 0$ kg/m³
Phantom section: TCoil Section

DASY 5 Configuration:

- Probe: AM1DV3 - 3115; ; Calibrated: 2019-06-14
- Sensor-Surface: 0mm (Fix Surface)
- Electronics: DAE4 Sn896; Calibrated: 2019-09-18
- Phantom: HAC Test Arch with AMCC; Type: SD HAC P01 BA;
- DASY52 52.8.8(1222); SEMCAD X 14.6.10(7331)

T-Coil scan/General Scans/z (axial) 4.2mm 50 x 50/ABM SNR(x,y,z) (13x13x1):

Measurement grid: dx=10mm, dy=10mm

ABM1/ABM2 = 30.43 dB

ABM1 comp = 1.20 dBA/m

BWC Factor = 0.16 dB

Location: 0, 0, 3.7 mm

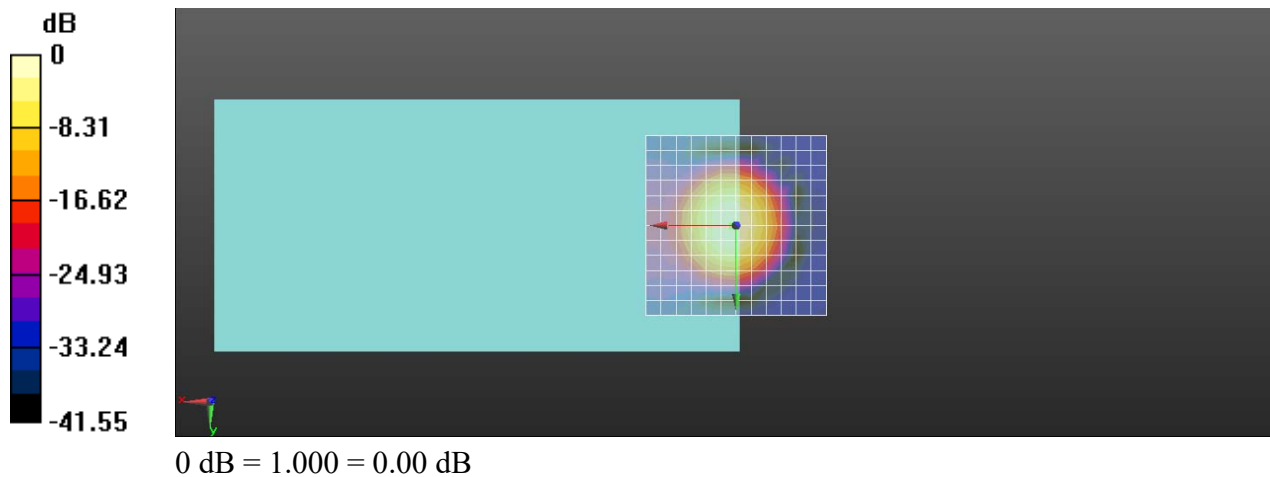

General Scans/z (axial) wideband at best S/N/ABM Freq Resp(x,y,z,f)

Loc: 1, 0.1, 3.7 mm Diff: 1.31dB

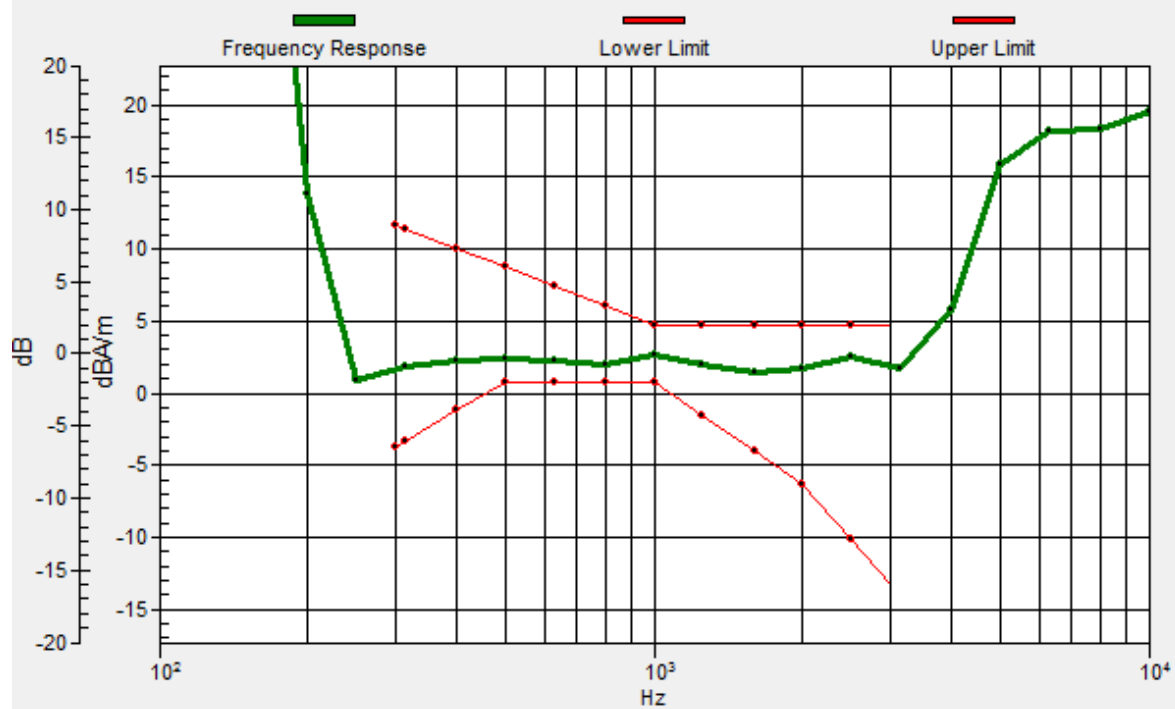

Test Laboratory: SGS-SAR Lab

U693CL HAC-T-Coil-CDMA BC1 600CH

DUT: U693CL; Type: Smartphone; Serial: 99001565000191

Communication System: UID 0, CDMA (0); Frequency: 1880 MHz;Duty Cycle: 1:1

Medium: Air;Medium parameters used: $\sigma = 0$ S/m, $\epsilon_r = 1$; $\rho = 0$ kg/m³
Phantom section: TCoil Section

DASY 5 Configuration:

- Probe: AM1DV3 - 3115; ; Calibrated: 2019-06-14
- Sensor-Surface: 0mm (Fix Surface)
- Electronics: DAE4 Sn896; Calibrated: 2019-09-18
- Phantom: HAC Test Arch with AMCC; Type: SD HAC P01 BA;
- DASY52 52.8.8(1222); SEMCAD X 14.6.10(7331)

T-Coil scan/General Scans/y (transversal) 4.2mm 50 x 50/ABM SNR(x,y,z)

(13x13x1): Measurement grid: dx=10mm, dy=10mm

ABM1/ABM2 = 29.30 dB

ABM1 comp = -7.36 dBA/m

BWC Factor = 0.16 dB

Location: 0, 8.3, 3.7 mm

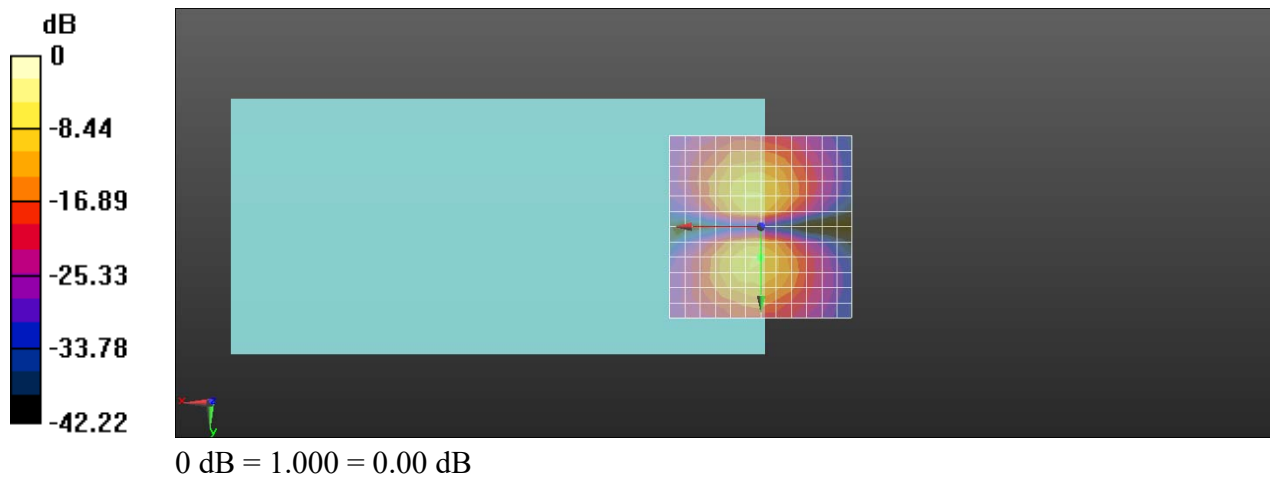

Test Laboratory: SGS-SAR Lab

U693CL HAC-T-Coil-CDMA BC10 580CH

DUT: U693CL; Type: Smartphone; Serial: 99001565000191

Communication System: UID 0, CDMA (0); Frequency: 820.5 MHz;Duty Cycle: 1:1

Medium: Air;Medium parameters used: $\sigma = 0$ S/m, $\epsilon_r = 1$; $\rho = 0$ kg/m³
Phantom section: TCoil Section

DASY 5 Configuration:

- Probe: AM1DV3 - 3115; ; Calibrated: 2019-06-14
- Sensor-Surface: 0mm (Fix Surface)
- Electronics: DAE4 Sn896; Calibrated: 2019-09-18
- Phantom: HAC Test Arch with AMCC; Type: SD HAC P01 BA;
- DASY52 52.8.8(1222); SEMCAD X 14.6.10(7331)

T-Coil scan/General Scans/z (axial) 4.2mm 50 x 50/ABM SNR(x,y,z) (13x13x1):

Measurement grid: dx=10mm, dy=10mm

ABM1/ABM2 = 31.04 dB

ABM1 comp = 1.28 dBA/m

BWC Factor = 0.16 dB

Location: 0, 0, 3.7 mm

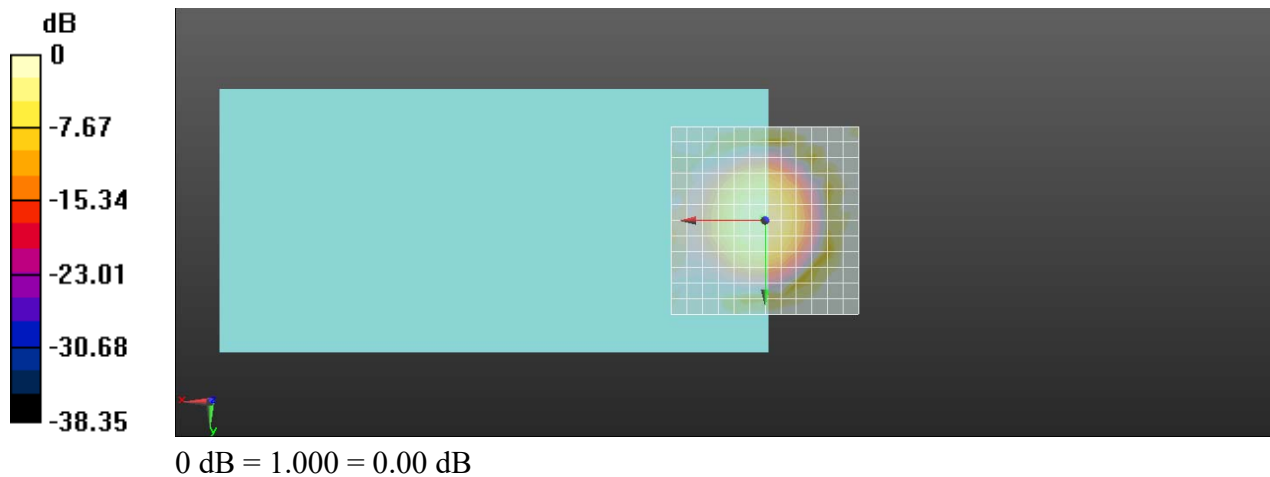

General Scans/z (axial) wideband at best S/N/ABM Freq Resp(x,y,z,f)

Loc: 0.5, -0.5, 3.7 mm Diff: 1.44dB

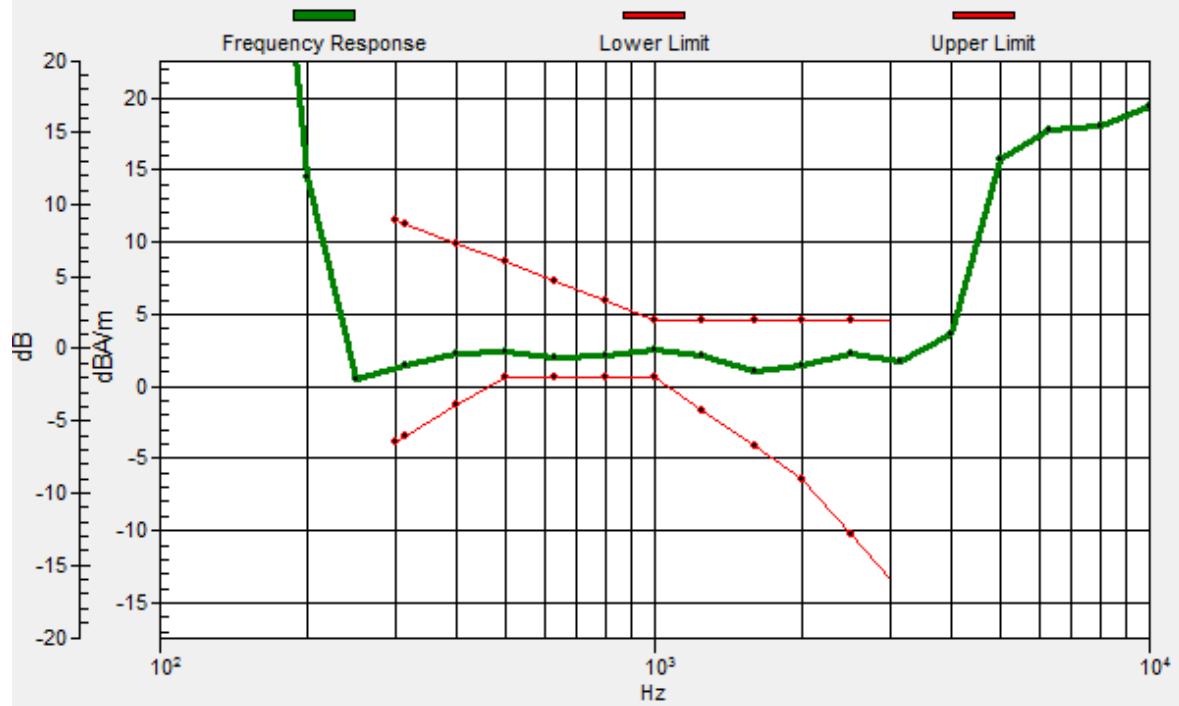

Test Laboratory: SGS-SAR Lab

U693CL HAC-T-Coil-CDMA BC10 580CH

DUT: U693CL; Type: Smartphone; Serial: 99001565000191

Communication System: UID 0, CDMA (0); Frequency: 820.5 MHz; Duty Cycle: 1:1

Medium: Air; Medium parameters used: $\sigma = 0$ S/m, $\epsilon_r = 1$; $\rho = 0$ kg/m³
Phantom section: TCoil Section

DASY 5 Configuration:

- Probe: AM1DV3 - 3115; ; Calibrated: 2019-06-14
- Sensor-Surface: 0mm (Fix Surface)
- Electronics: DAE4 Sn896; Calibrated: 2019-09-18
- Phantom: HAC Test Arch with AMCC; Type: SD HAC P01 BA;
- DASY52 52.8.8(1222); SEMCAD X 14.6.10(7331)

T-Coil scan/General Scans/y (transversal) 4.2mm 50 x 50/ABM SNR(x,y,z)

(13x13x1): Measurement grid: dx=10mm, dy=10mm

ABM1/ABM2 = 30.58 dB

ABM1 comp = -6.63 dBA/m

BWC Factor = 0.16 dB

Location: 0, 8.3, 3.7 mm

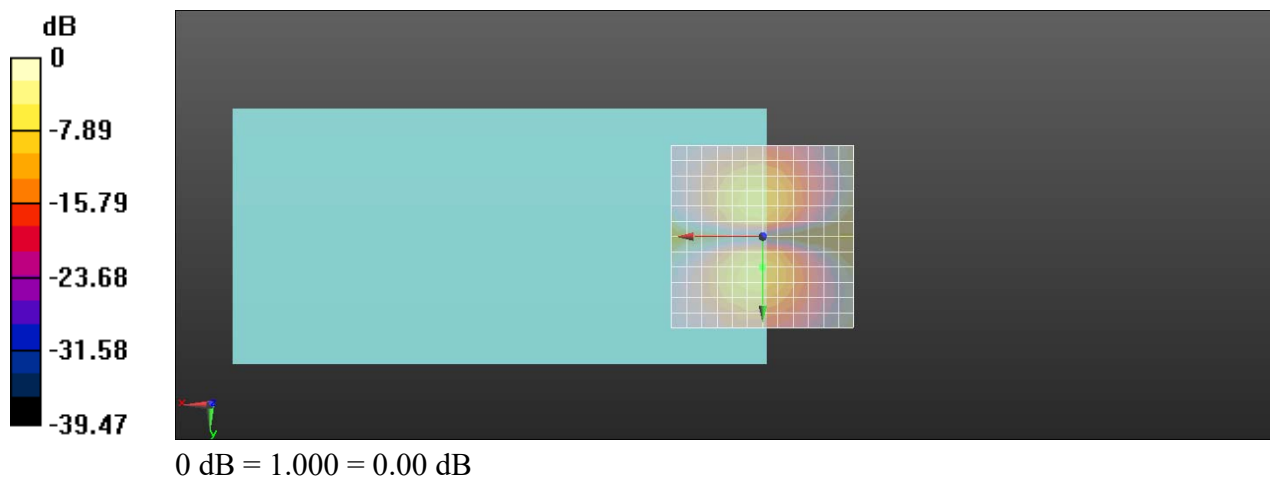

Test Laboratory: SGS-SAR Lab

U693CL HAC-T-Coil-LTE Band 12 10M QPSK 1RB0 23095CH

DUT: U693CL; Type: Smartphone; Serial: 99001565000191

Communication System: UID 0, LTE-FDD BW 10MHZ (0); Frequency: 707.5 MHz;Duty Cycle: 1:1

Medium: Air;Medium parameters used: $\sigma = 0$ S/m, $\epsilon_r = 1$; $\rho = 0$ kg/m³
Phantom section: TCoil Section

DASY 5 Configuration:

- Probe: AM1DV3 - 3115; ; Calibrated: 2019-06-14
- Sensor-Surface: 0mm (Fix Surface)
- Electronics: DAE4 Sn896; Calibrated: 2019-09-18
- Phantom: HAC Test Arch with AMCC; Type: SD HAC P01 BA;
- DASY52 52.8.8(1222); SEMCAD X 14.6.10(7331)

T-Coil scan/General Scans/z (axial) 4.2mm 50 x 50/ABM SNR(x,y,z) (13x13x1):

Measurement grid: dx=10mm, dy=10mm

ABM1/ABM2 = 29.37 dB

ABM1 comp = 0.92 dBA/m

BWC Factor = 0.17 dB

Location: 4.2, 0, 3.7 mm

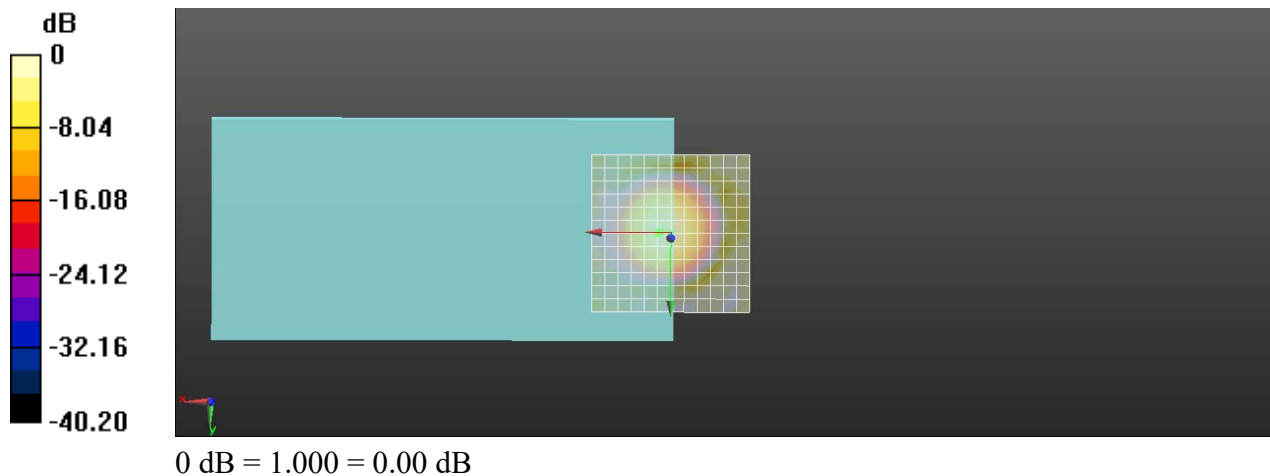

General Scans/z (axial) wideband at best S/N/ABM Freq Resp(x,y,z,f)

Loc: 3.2, -0.4, 3.7 mm Diff: 0.77dB

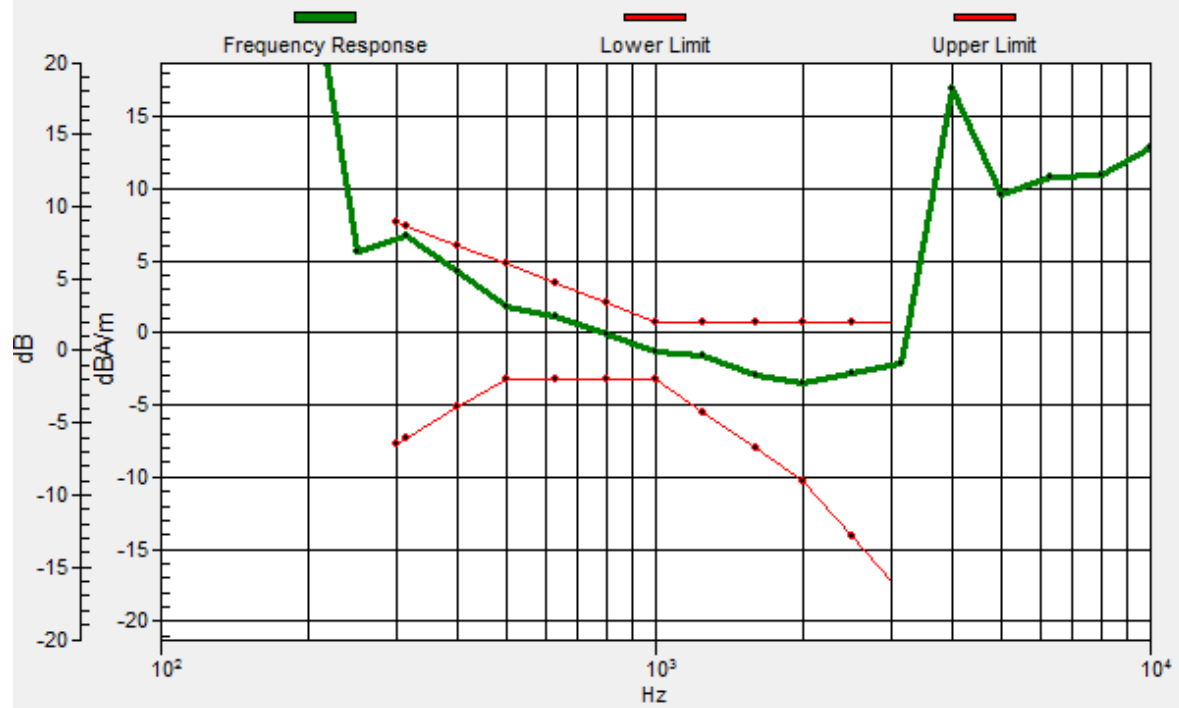

Test Laboratory: SGS-SAR Lab

U693CL HAC-T-Coil-LTE Band 12 10M QPSK 1RB0 23095CH

DUT: U693CL; Type: Smartphone; Serial: 99001565000191

Communication System: UID 0, LTE-FDD BW 10MHZ (0); Frequency: 707.5 MHz;Duty Cycle: 1:1

Medium: Air;Medium parameters used: $\sigma = 0$ S/m, $\epsilon_r = 1$; $\rho = 0$ kg/m³
Phantom section: TCoil Section

DASY 5 Configuration:

- Probe: AM1DV3 - 3115; ; Calibrated: 2019-06-14
- Sensor-Surface: 0mm (Fix Surface)
- Electronics: DAE4 Sn896; Calibrated: 2019-09-18
- Phantom: HAC Test Arch with AMCC; Type: SD HAC P01 BA;
- DASY52 52.8.8(1222); SEMCAD X 14.6.10(7331)

T-Coil scan/General Scans/y (transversal) 4.2mm 50 x 50/ABM SNR(x,y,z)

(13x13x1): Measurement grid: dx=10mm, dy=10mm

ABM1/ABM2 = 26.58 dB

ABM1 comp = -7.70 dBA/m

BWC Factor = 0.17 dB

Location: 0, -8.3, 3.7 mm

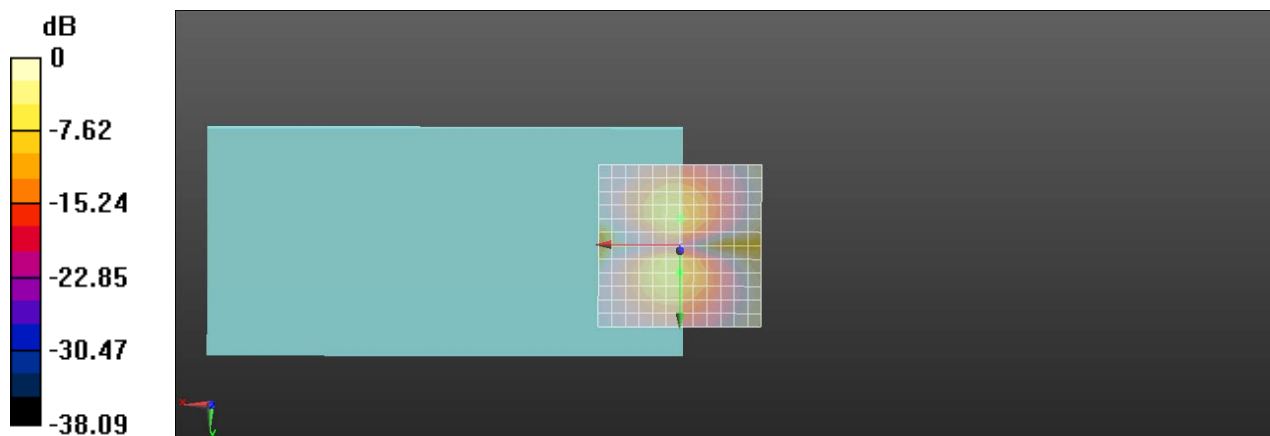

0 dB = 1.000 = 0.00 dB

Test Laboratory: SGS-SAR Lab

U693CL HAC-T-Coil-LTE Band 12 10M QPSK 1RB0 23095CH

DUT: U693CL; Type: Smartphone; Serial: 99001565000134

Communication System: UID 0, LTE-FDD BW 10MHZ (0); Frequency: 707.5 MHz;Duty Cycle: 1:1

Medium: Air;Medium parameters used: $\sigma = 0$ S/m, $\epsilon_r = 1$; $\rho = 0$ kg/m³
Phantom section: TCoil Section

DASY 5 Configuration:

- Probe: AM1DV3 - 3115; ; Calibrated: 2019-06-14
- Sensor-Surface: 0mm (Fix Surface)
- Electronics: DAE4 Sn896; Calibrated: 2019-09-18
- Phantom: HAC Test Arch with AMCC; Type: SD HAC P01 BA;
- DASY52 52.8.8(1222); SEMCAD X 14.6.10(7331)

T-Coil scan/General Scans/z (axial) 4.2mm 50 x 50/ABM SNR(x,y,z) (13x13x1):

Measurement grid: dx=10mm, dy=10mm

ABM1/ABM2 = 34.23 dB

ABM1 comp = 4.34 dBA/m

BWC Factor = 0.16 dB

Location: 0, 0, 3.7 mm

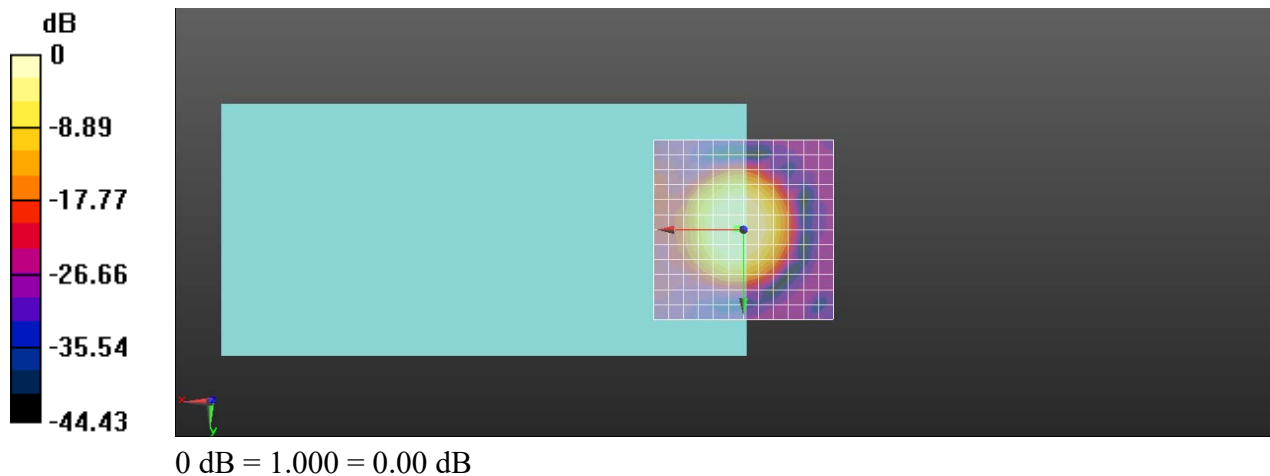

General Scans/z (axial) wideband at best S/N/ABM Freq Resp(x,y,z,f)

Loc: 1.8, -0.3, 3.7 mm Diff: 0.89dB

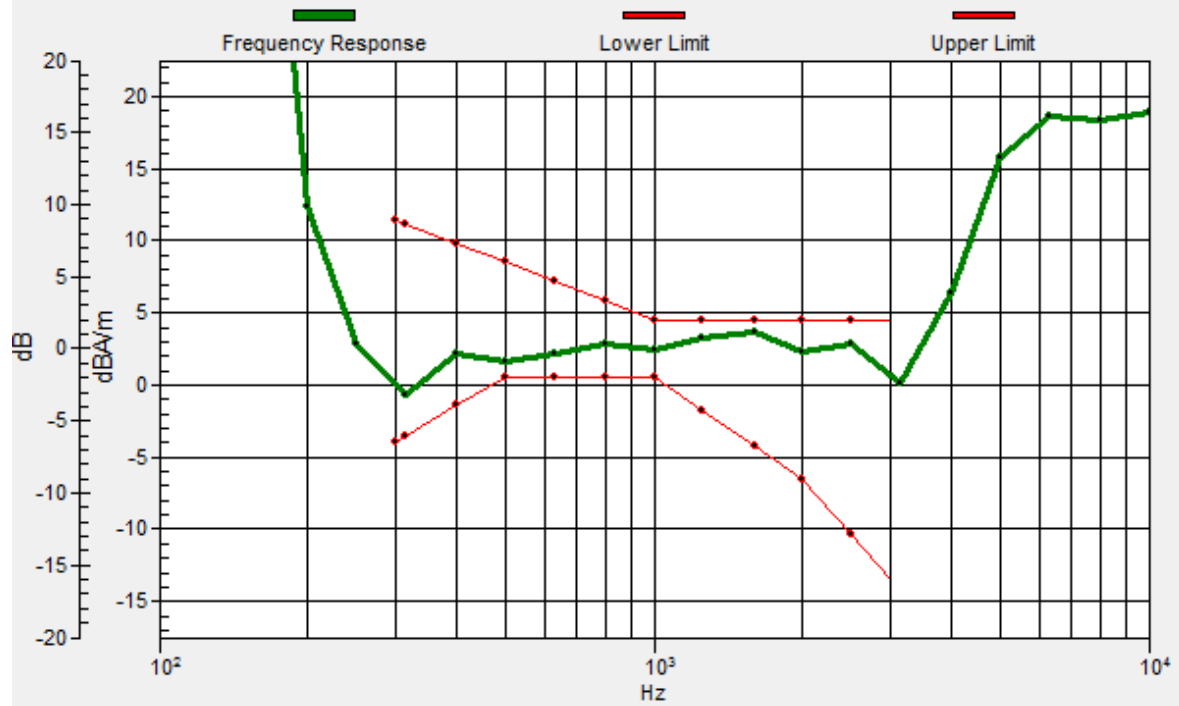

Test Laboratory: SGS-SAR Lab

U693CL HAC-T-Coil-LTE Band 12 10M QPSK 1RB0 23095CH

DUT: U693CL; Type: Smartphone; Serial: 99001565000134

Communication System: UID 0, LTE-FDD BW 10MHZ (0); Frequency: 707.5 MHz;Duty Cycle: 1:1

Medium: Air;Medium parameters used: $\sigma = 0$ S/m, $\epsilon_r = 1$; $\rho = 0$ kg/m³

Phantom section: TCoil Section

DASY 5 Configuration:

- Probe: AM1DV3 - 3115; ; Calibrated: 2019-06-14
- Sensor-Surface: 0mm (Fix Surface)
- Electronics: DAE4 Sn896; Calibrated: 2019-09-18
- Phantom: HAC Test Arch with AMCC; Type: SD HAC P01 BA;
- DASY52 52.8.8(1222); SEMCAD X 14.6.10(7331)

T-Coil scan/General Scans/y (transversal) 4.2mm 50 x 50/ABM SNR(x,y,z)

(13x13x1): Measurement grid: dx=10mm, dy=10mm

ABM1/ABM2 = 32.88 dB

ABM1 comp = -5.21 dBA/m

BWC Factor = 0.16 dB

Location: 0, -8.3, 3.7 mm

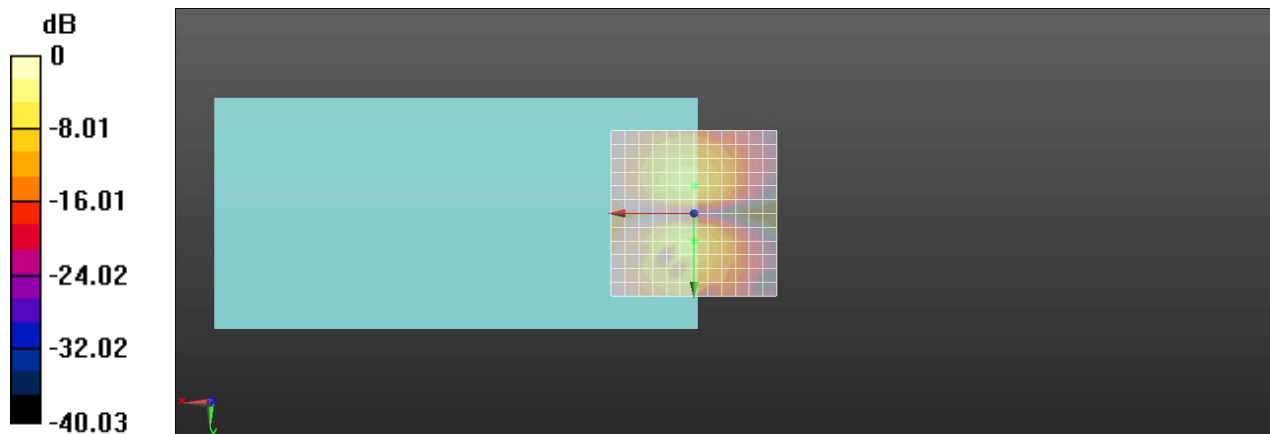

0 dB = 1.000 = 0.00 dB

Test Laboratory: SGS-SAR Lab

U693CL HAC-T-Coil-LTE Band 25 20M QPSK 1RB0 26365CH

DUT: U693CL; Type: Smartphone; Serial: 99001565000191

Communication System: UID 0, LTE-FDD BW 20MHz (0); Frequency: 1882.5 MHz;Duty Cycle: 1:1

Medium: Air;Medium parameters used: $\sigma = 0$ S/m, $\epsilon_r = 1$; $\rho = 0$ kg/m³
Phantom section: TCoil Section

DASY 5 Configuration:

- Probe: AM1DV3 - 3115; ; Calibrated: 2019-06-14
- Sensor-Surface: 0mm (Fix Surface)
- Electronics: DAE4 Sn896; Calibrated: 2019-09-18
- Phantom: HAC Test Arch with AMCC; Type: SD HAC P01 BA;
- DASY52 52.8.8(1222); SEMCAD X 14.6.10(7331)

T-Coil scan/General Scans/z (axial) 4.2mm 50 x 50/ABM SNR(x,y,z) (13x13x1):

Measurement grid: dx=10mm, dy=10mm

ABM1/ABM2 = 28.54 dB

ABM1 comp = 0.72 dBA/m

BWC Factor = 0.17 dB

Location: 0, 0, 3.7 mm

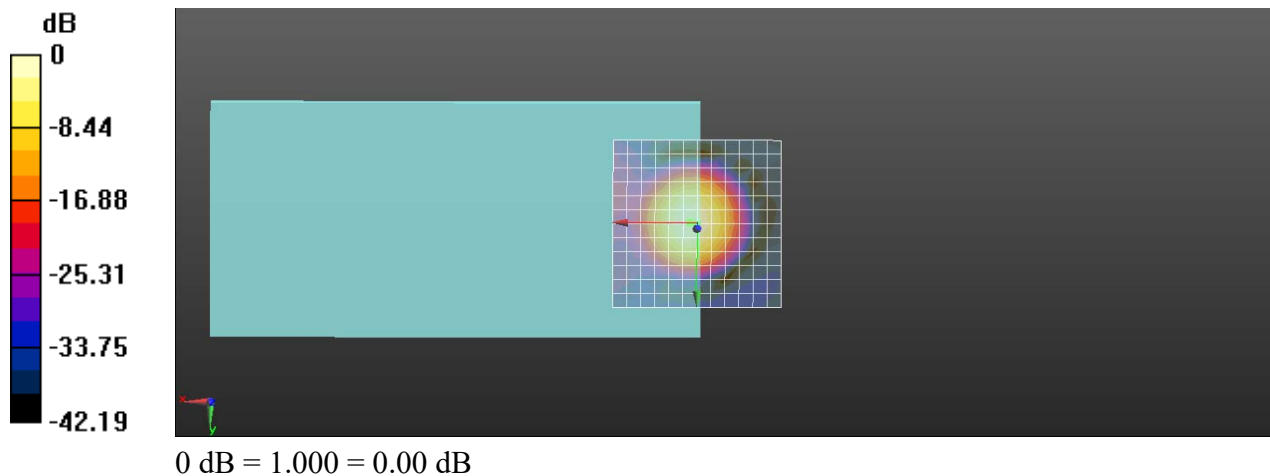

General Scans/z (axial) wideband at best S/N/ABM Freq Resp(x,y,z,f)

Loc: 2.2, -0.5, 3.7 mm Diff: 0.94dB

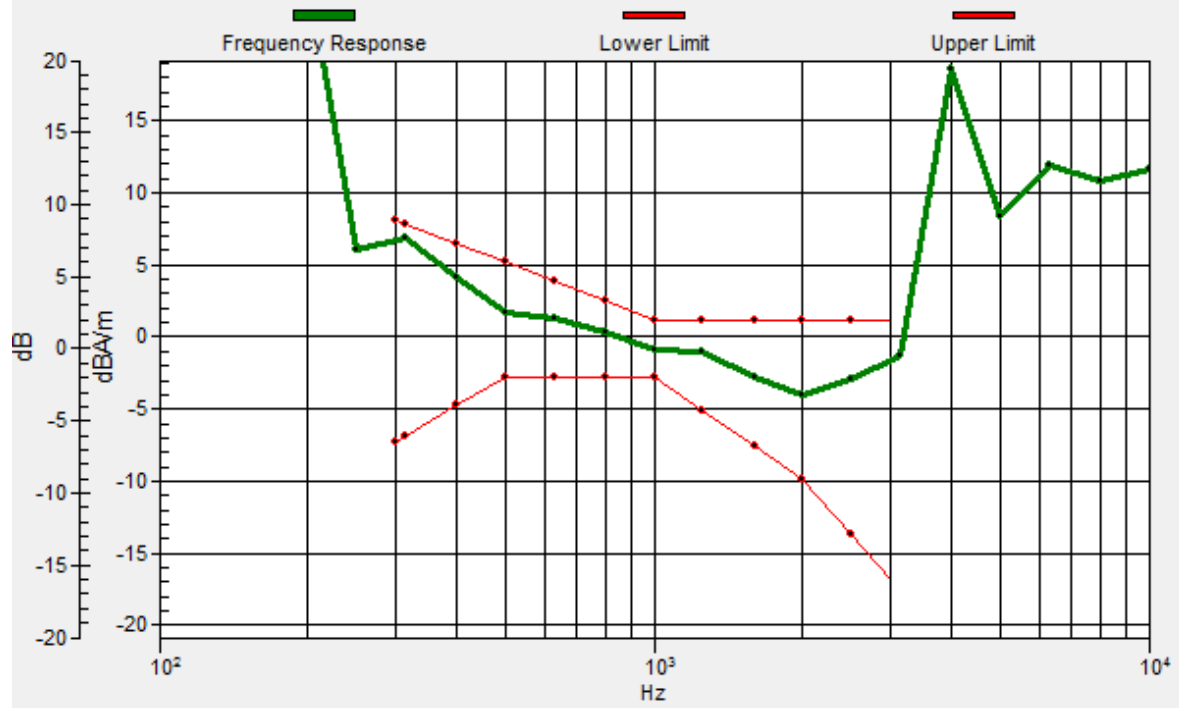

Test Laboratory: SGS-SAR Lab

U693CL HAC-T-Coil-LTE Band 25 20M QPSK 1RB0 26365CH

DUT: U693CL; Type: Smartphone; Serial: 99001565000191

Communication System: UID 0, LTE-FDD BW 20MHz (0); Frequency: 1882.5 MHz;Duty Cycle: 1:1

Medium: Air;Medium parameters used: $\sigma = 0$ S/m, $\epsilon_r = 1$; $\rho = 0$ kg/m³
Phantom section: TCoil Section

DASY 5 Configuration:

- Probe: AM1DV3 - 3115; ; Calibrated: 2019-06-14
- Sensor-Surface: 0mm (Fix Surface)
- Electronics: DAE4 Sn896; Calibrated: 2019-09-18
- Phantom: HAC Test Arch with AMCC; Type: SD HAC P01 BA;
- DASY52 52.8.8(1222); SEMCAD X 14.6.10(7331)

T-Coil scan/General Scans/y (transversal) 4.2mm 50 x 50/ABM SNR(x,y,z)

(13x13x1): Measurement grid: dx=10mm, dy=10mm

ABM1/ABM2 = 27.67 dB

ABM1 comp = -7.51 dBA/m

BWC Factor = 0.17 dB

Location: 0, 8.3, 3.7 mm

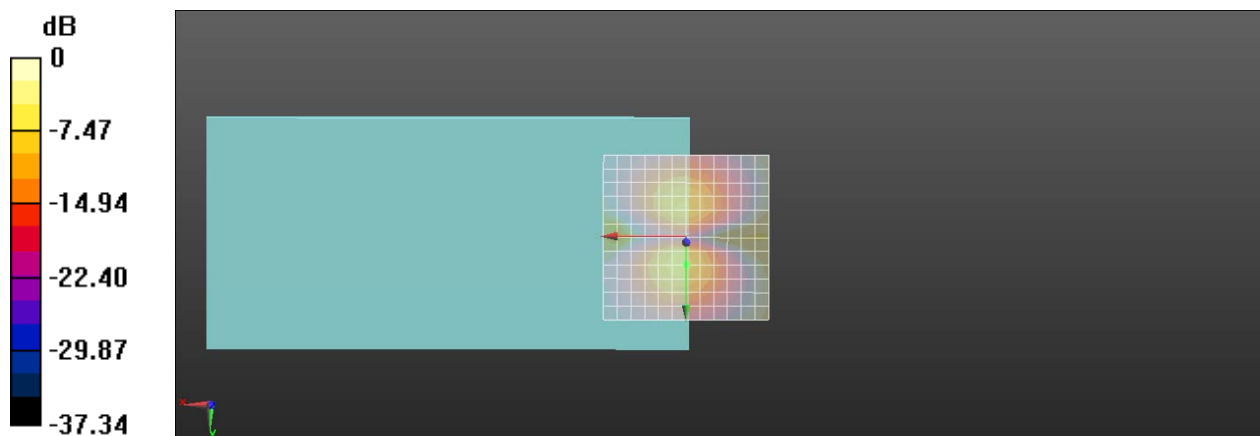

0 dB = 1.000 = 0.00 dB

Test Laboratory: SGS-SAR Lab

U693CL HAC-T-Coil-LTE Band 26 15M QPSK 1RB0 26865CH

DUT: U693CL; Type: Smartphone; Serial: 99001565000191

Communication System: UID 0, LTE-FDD BW 15MHz (0); Frequency: 831.5 MHz;Duty Cycle: 1:1

Medium: Air;Medium parameters used: $\sigma = 0$ S/m, $\epsilon_r = 1$; $\rho = 0$ kg/m³

Phantom section: TCoil Section

DASY 5 Configuration:

- Probe: AM1DV3 - 3115; ; Calibrated: 2019-06-14
- Sensor-Surface: 0mm (Fix Surface)
- Electronics: DAE4 Sn896; Calibrated: 2019-09-18
- Phantom: HAC Test Arch with AMCC; Type: SD HAC P01 BA;
- DASY52 52.8.8(1222); SEMCAD X 14.6.10(7331)

T-Coil scan/General Scans/z (axial) 4.2mm 50 x 50/ABM SNR(x,y,z) (13x13x1):

Measurement grid: dx=10mm, dy=10mm

ABM1/ABM2 = 30.35 dB

ABM1 comp = 0.97 dBA/m

BWC Factor = 0.17 dB

Location: 4.2, 0, 3.7 mm

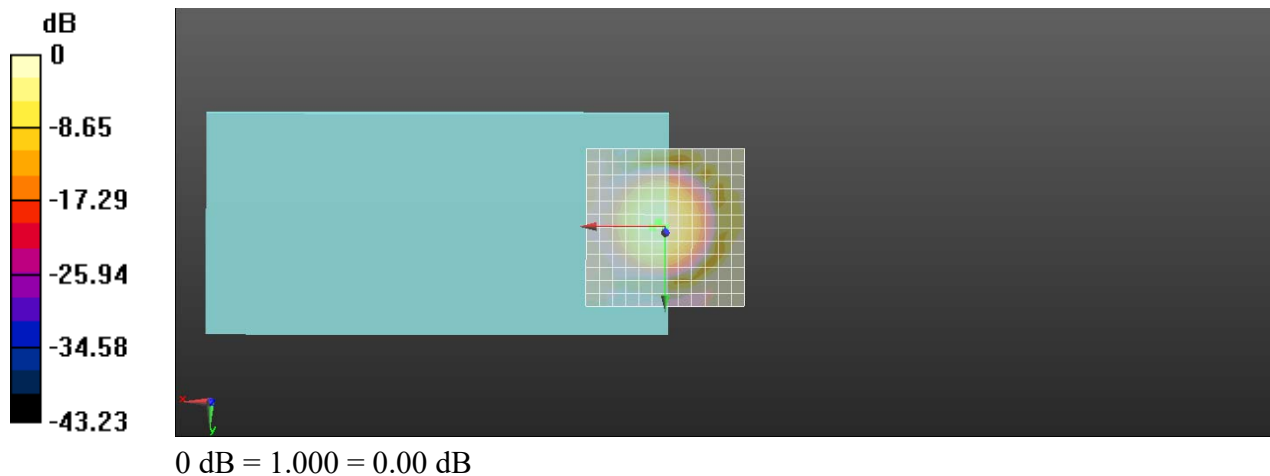

General Scans/z (axial) wideband at best S/N/ABM Freq Resp(x,y,z,f)

Loc: 2.1, -1.6, 3.7 mm Diff: 1.03dB

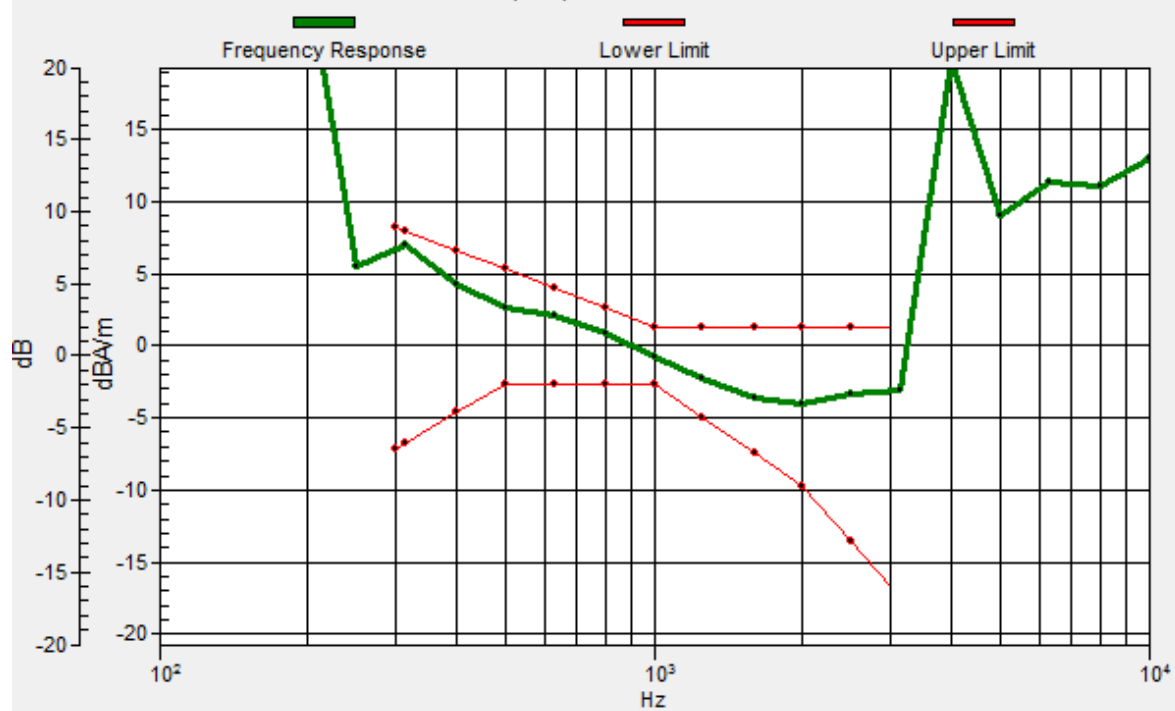

Test Laboratory: SGS-SAR Lab

U693CL HAC-T-Coil-LTE Band 26 15M QPSK 1RB0 26865CH

DUT: U693CL; Type: Smartphone; Serial: 99001565000191

Communication System: UID 0, LTE-FDD BW 15MHz (0); Frequency: 831.5 MHz;Duty Cycle: 1:1

Medium: Air;Medium parameters used: $\sigma = 0$ S/m, $\epsilon_r = 1$; $\rho = 0$ kg/m³
Phantom section: TCoil Section

DASY 5 Configuration:

- Probe: AM1DV3 - 3115; ; Calibrated: 2019-06-14
- Sensor-Surface: 0mm (Fix Surface)
- Electronics: DAE4 Sn896; Calibrated: 2019-09-18
- Phantom: HAC Test Arch with AMCC; Type: SD HAC P01 BA;
- DASY52 52.8.8(1222); SEMCAD X 14.6.10(7331)

T-Coil scan/General Scans/y (transversal) 4.2mm 50 x 50/ABM SNR(x,y,z)

(13x13x1): Measurement grid: dx=10mm, dy=10mm

ABM1/ABM2 = 29.72 dB

ABM1 comp = -7.21 dBA/m

BWC Factor = 0.17 dB

Location: 0, 8.3, 3.7 mm

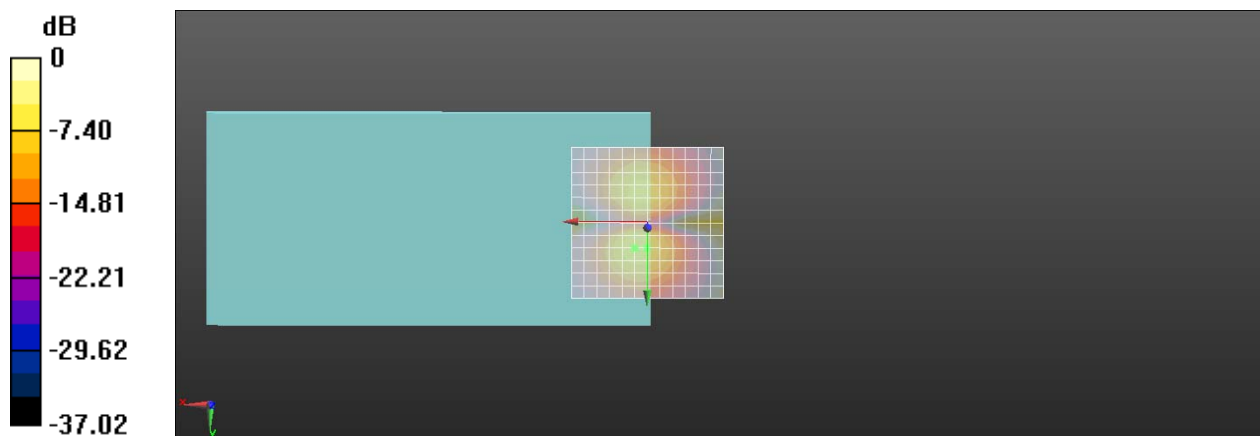

Test Laboratory: SGS-SAR Lab

U693CL HAC-T-Coil-LTE Band 66 20M QPSK 1RB0 132322CH

DUT: U693CL; Type: Smartphone; Serial: 99001565000191

Communication System: UID 0, LTE-FDD BW 20MHz (0); Frequency: 1745 MHz;Duty Cycle: 1:1

Medium: Air;Medium parameters used: $\sigma = 0$ S/m, $\epsilon_r = 1$; $\rho = 0$ kg/m³

Phantom section: TCoil Section

DASY 5 Configuration:

- Probe: AM1DV3 - 3115; ; Calibrated: 2019-06-14
- Sensor-Surface: 0mm (Fix Surface)
- Electronics: DAE4 Sn896; Calibrated: 2019-09-18
- Phantom: HAC Test Arch with AMCC; Type: SD HAC P01 BA;
- DASY52 52.8.8(1222); SEMCAD X 14.6.10(7331)

T-Coil scan/General Scans/z (axial) 4.2mm 50 x 50/ABM SNR(x,y,z) (13x13x1):

Measurement grid: dx=10mm, dy=10mm

ABM1/ABM2 = 29.55 dB

ABM1 comp = 1.16 dBA/m

BWC Factor = 0.17 dB

Location: 0, 0, 3.7 mm

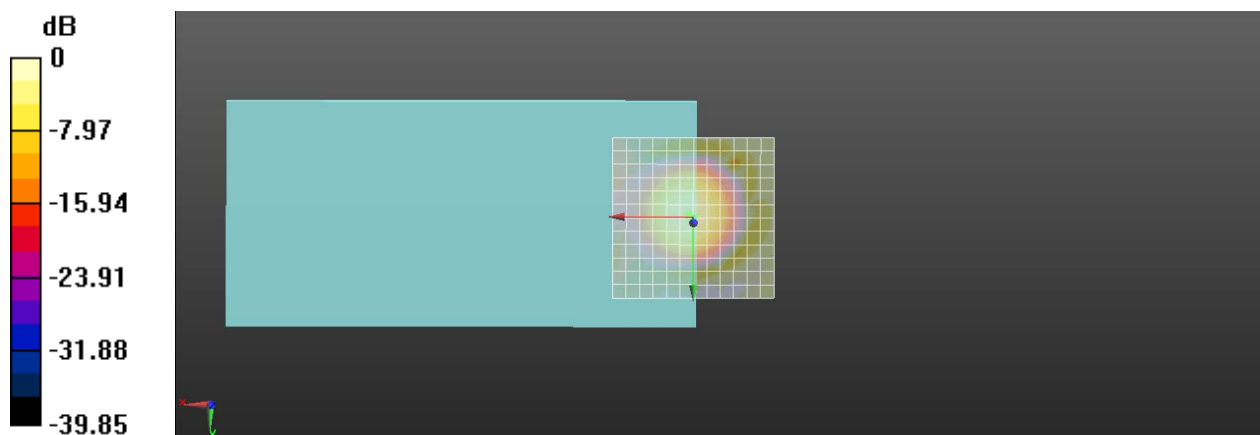

0 dB = 1.000 = 0.00 dB

General Scans/z (axial) wideband at best S/N/ABM Freq Resp(x,y,z,f)

Loc: 1.5, -1, 3.7 mm Diff: 1.35dB

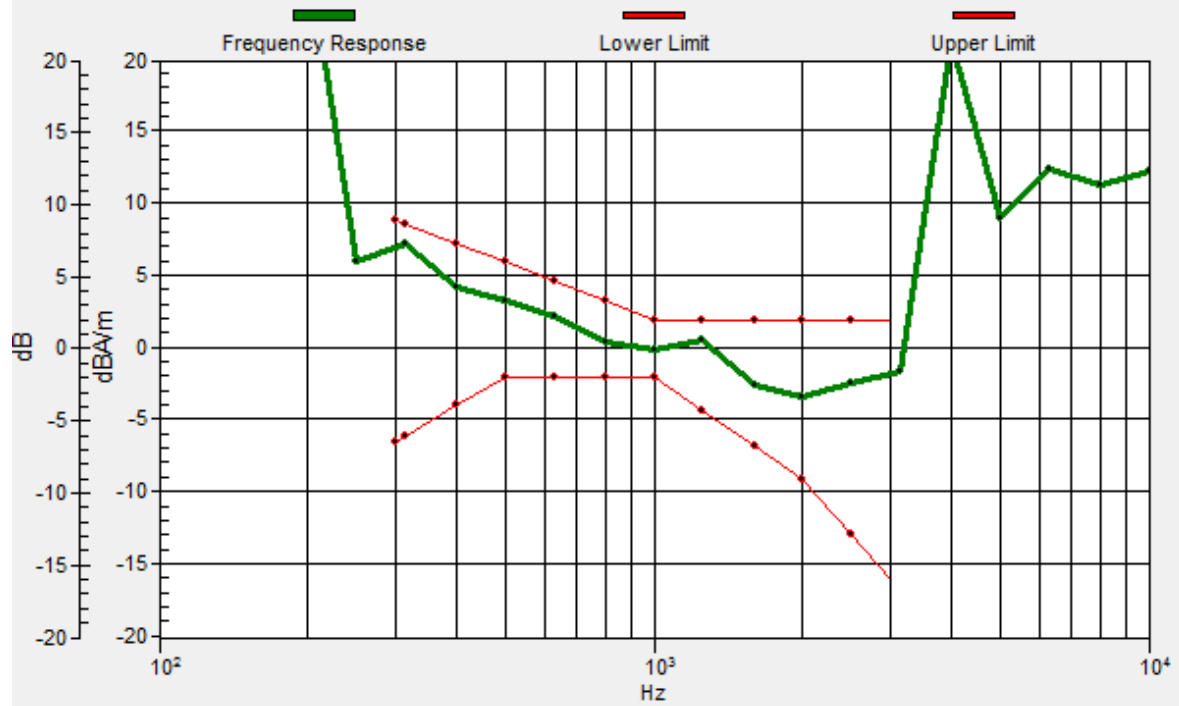

Test Laboratory: SGS-SAR Lab

U693CL HAC-T-Coil-LTE Band 66 20M QPSK 1RB0 132322CH

DUT: U693CL; Type: Smartphone; Serial: 99001565000191

Communication System: UID 0, LTE-FDD BW 20MHz (0); Frequency: 1745 MHz;Duty Cycle: 1:1

Medium: Air;Medium parameters used: $\sigma = 0$ S/m, $\epsilon_r = 1$; $\rho = 0$ kg/m³
Phantom section: TCoil Section

DASY 5 Configuration:

- Probe: AM1DV3 - 3115; ; Calibrated: 2019-06-14
- Sensor-Surface: 0mm (Fix Surface)
- Electronics: DAE4 Sn896; Calibrated: 2019-09-18
- Phantom: HAC Test Arch with AMCC; Type: SD HAC P01 BA;
- DASY52 52.8.8(1222); SEMCAD X 14.6.10(7331)

T-Coil scan/General Scans/y (transversal) 4.2mm 50 x 50/ABM SNR(x,y,z)

(13x13x1): Measurement grid: dx=10mm, dy=10mm

ABM1/ABM2 = 29.56 dB

ABM1 comp = -6.98 dBA/m

BWC Factor = 0.17 dB

Location: 0, 8.3, 3.7 mm

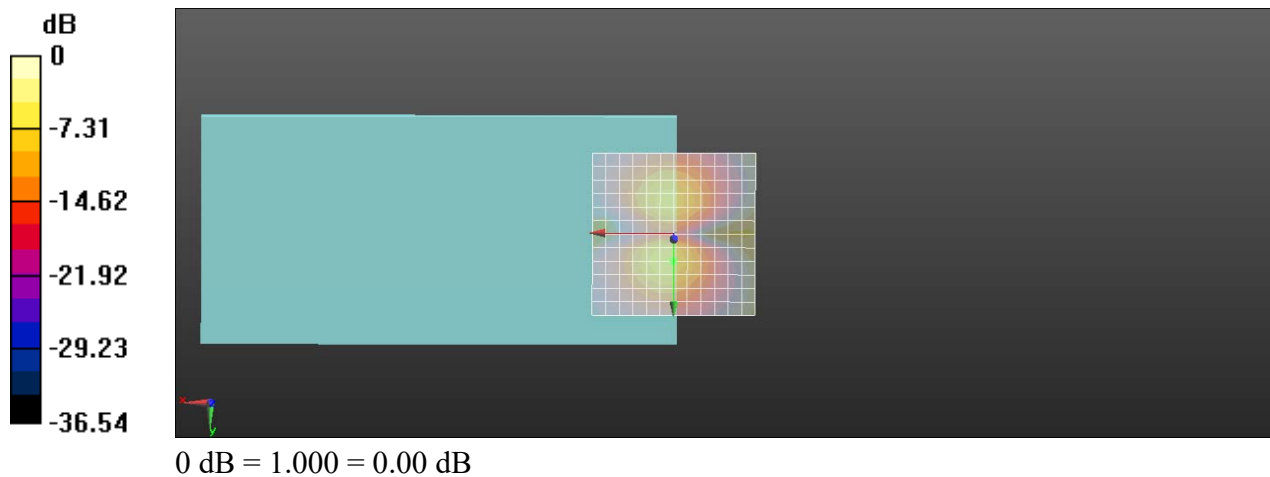

Test Laboratory: SGS-SAR Lab

U693CL HAC-T-Coil-LTE Band 71 20M QPSK 1RB0 133297CH

DUT: U693CL; Type: Smartphone; Serial: 99001565000191

Communication System: UID 0, LTE-FDD BW 20MHz (0); Frequency: 680.5 MHz;Duty Cycle: 1:1

Medium: Air;Medium parameters used: $\sigma = 0$ S/m, $\epsilon_r = 1$; $\rho = 0$ kg/m³

Phantom section: TCoil Section

DASY 5 Configuration:

- Probe: AM1DV3 - 3115; ; Calibrated: 2019-06-14
- Sensor-Surface: 0mm (Fix Surface)
- Electronics: DAE4 Sn896; Calibrated: 2019-09-18
- Phantom: HAC Test Arch with AMCC; Type: SD HAC P01 BA;
- DASY52 52.8.8(1222); SEMCAD X 14.6.10(7331)

T-Coil scan/General Scans/z (axial) 4.2mm 50 x 50/ABM SNR(x,y,z) (13x13x1):

Measurement grid: dx=10mm, dy=10mm

ABM1/ABM2 = 28.20 dB

ABM1 comp = 0.70 dBA/m

BWC Factor = 0.17 dB

Location: 0, -4.2, 3.7 mm

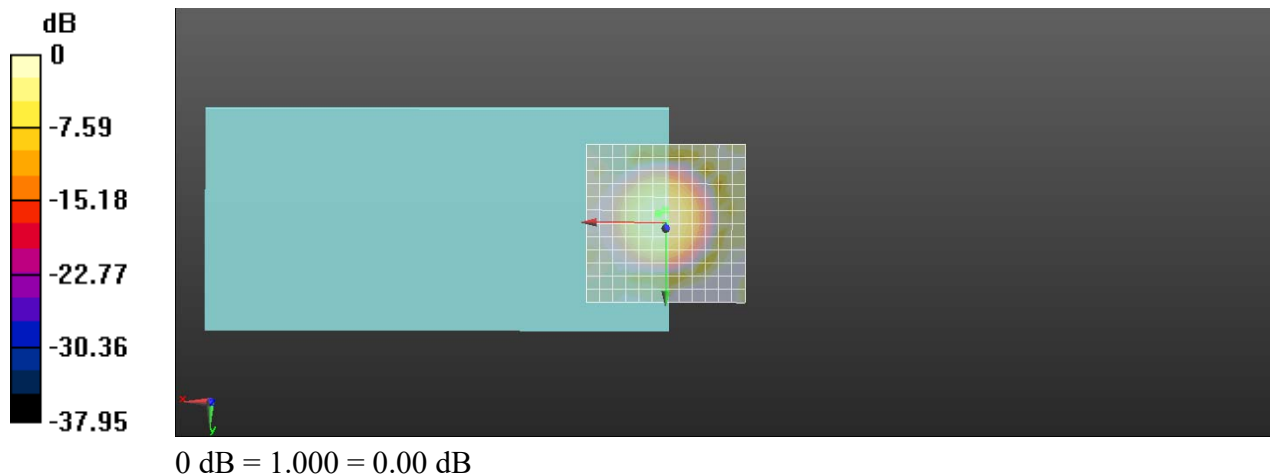

General Scans/z (axial) wideband at best S/N/ABM Freq Resp(x,y,z,f)

Loc: 2.3, -3, 3.7 mm Diff: 1.19dB

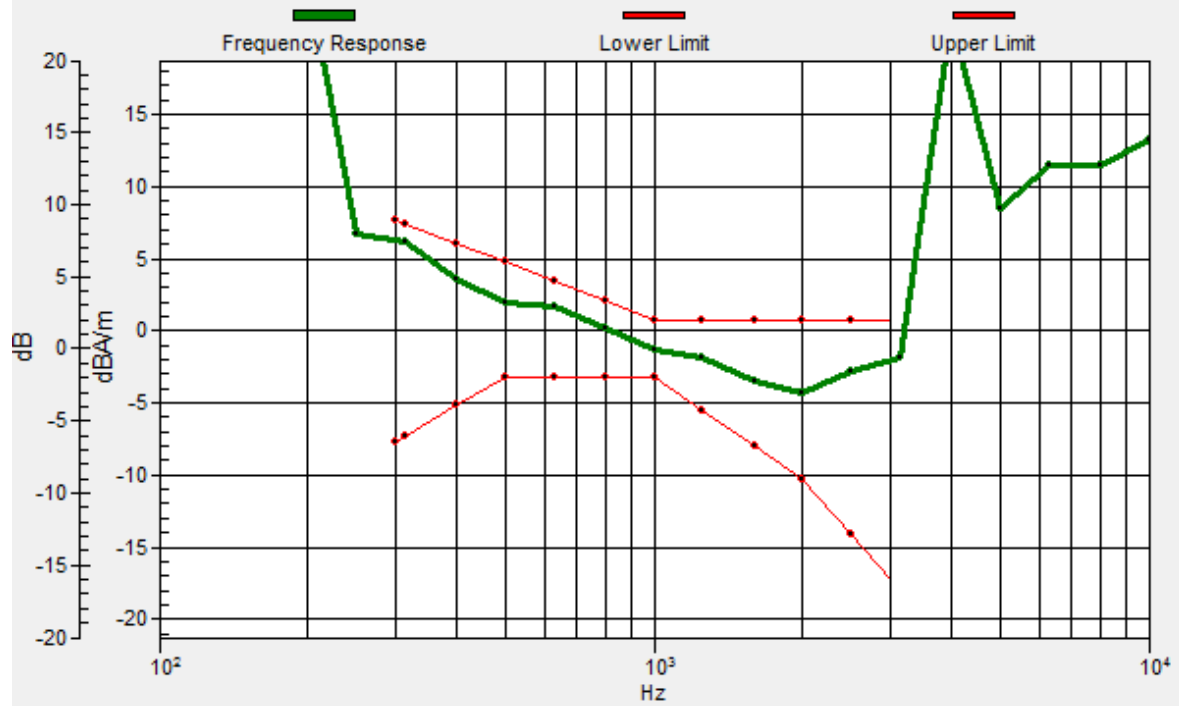

Test Laboratory: SGS-SAR Lab

U693CL HAC-T-Coil-LTE Band 71 20M QPSK 1RB0 133297CH

DUT: U693CL; Type: Smartphone; Serial: 99001565000191

Communication System: UID 0, LTE-FDD BW 20MHz (0); Frequency: 680.5 MHz;Duty Cycle: 1:1

Medium: Air;Medium parameters used: $\sigma = 0$ S/m, $\epsilon_r = 1$; $\rho = 0$ kg/m³

Phantom section: TCoil Section

DASY 5 Configuration:

- Probe: AM1DV3 - 3115; ; Calibrated: 2019-06-14
- Sensor-Surface: 0mm (Fix Surface)
- Electronics: DAE4 Sn896; Calibrated: 2019-09-18
- Phantom: HAC Test Arch with AMCC; Type: SD HAC P01 BA;
- DASY52 52.8.8(1222); SEMCAD X 14.6.10(7331)

T-Coil scan/General Scans/y (transversal) 4.2mm 50 x 50/ABM SNR(x,y,z)

(13x13x1): Measurement grid: dx=10mm, dy=10mm

ABM1/ABM2 = 29.14 dB

ABM1 comp = -8.01 dBA/m

BWC Factor = 0.17 dB

Location: 0, -8.3, 3.7 mm

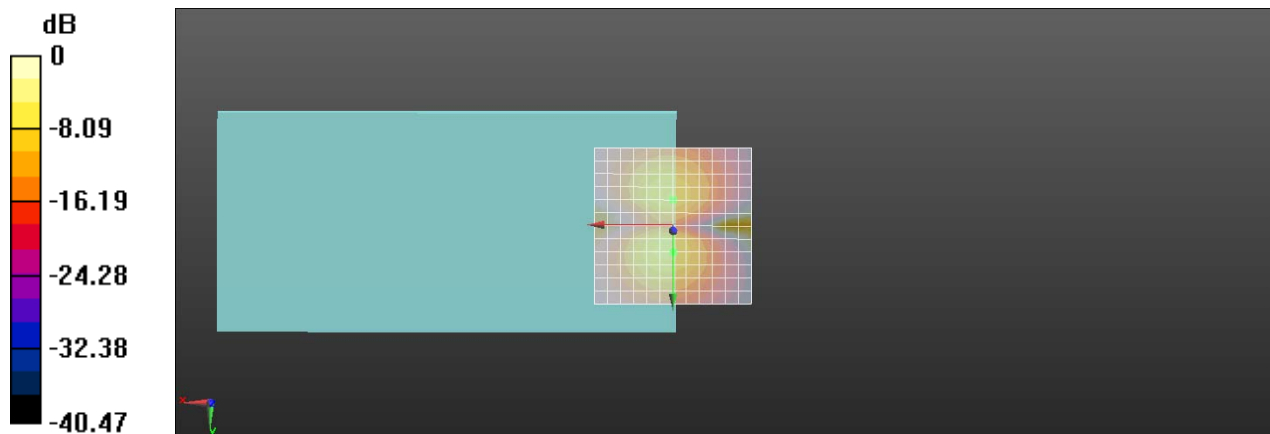

0 dB = 1.000 = 0.00 dB

Test Laboratory: SGS-SAR Lab

U693CL HAC-T-Coil-LTE Band 41 20M QPSK 1RB0 40620CH-WB AMR 6.6Kbps

DUT: U693CL; Type: Smartphone; Serial: 99001565000191

Communication System: UID 0, LTE-TDD BW 20MHz (0); Frequency: 2593 MHz;Duty Cycle: 1:1.57906

Medium: Air;Medium parameters used: $\sigma = 0$ S/m, $\epsilon_r = 1$; $\rho = 0$ kg/m³

Phantom section: TCoil Section

DASY 5 Configuration:

- Probe: AM1DV3 - 3115; ; Calibrated: 2019-06-14
- Sensor-Surface: 0mm (Fix Surface)
- Electronics: DAE4 Sn896; Calibrated: 2019-09-18
- Phantom: HAC Test Arch with AMCC; Type: SD HAC P01 BA;
- DASY52 52.8.8(1222); SEMCAD X 14.6.10(7331)

T-Coil scan/General Scans/z (axial) 4.2mm 50 x 50/ABM SNR(x,y,z) (13x13x1):

Measurement grid: dx=10mm, dy=10mm

ABM1/ABM2 = 27.51 dB

ABM1 comp = 0.68 dBA/m

BWC Factor = 0.16 dB

Location: 0, 0, 3.7 mm

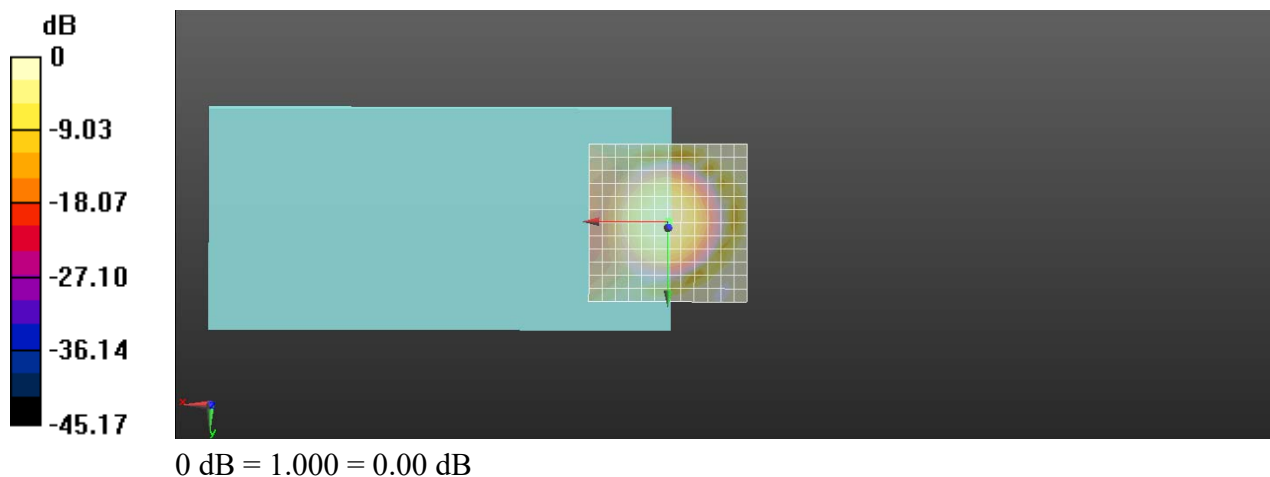

General Scans/z (axial) wideband at best S/N/ABM Freq Resp(x,y,z,f)

Loc: -0.4, -0.4, 3.7 mm Diff: 2dB

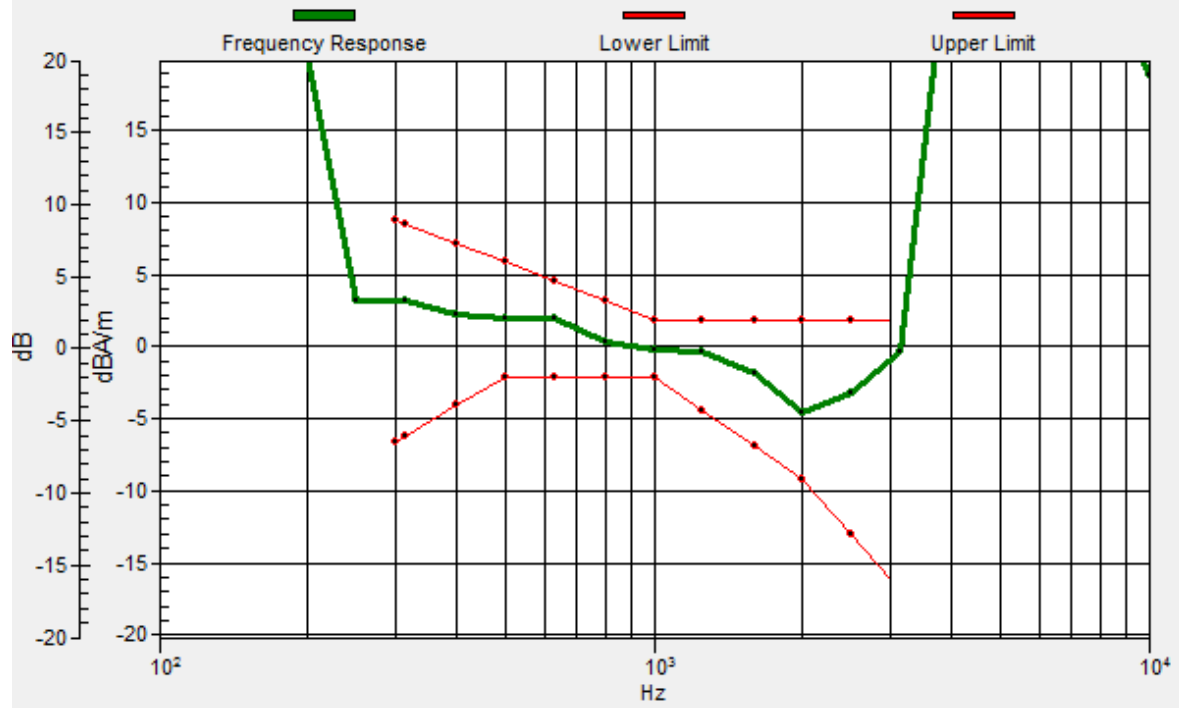

Test Laboratory: SGS-SAR Lab

U693CL HAC-T-Coil-LTE Band 41 20M QPSK 1RB0 40620CH-WB AMR 6.6Kbps

DUT: U693CL; Type: Smartphone; Serial: 99001565000191

Communication System: UID 0, LTE-TDD BW 20MHz (0); Frequency: 2593 MHz; Duty Cycle: 1:1.57906

Medium: Air; Medium parameters used: $\sigma = 0$ S/m, $\epsilon_r = 1$; $\rho = 0$ kg/m³

Phantom section: TCoil Section

DASY 5 Configuration:

- Probe: AM1DV3 - 3115; ; Calibrated: 2019-06-14
- Sensor-Surface: 0mm (Fix Surface)
- Electronics: DAE4 Sn896; Calibrated: 2019-09-18
- Phantom: HAC Test Arch with AMCC; Type: SD HAC P01 BA;
- DASY52 52.8.8(1222); SEMCAD X 14.6.10(7331)

T-Coil scan/General Scans/y (transversal) 4.2mm 50 x 50/ABM SNR(x,y,z)

(13x13x1): Measurement grid: dx=10mm, dy=10mm

ABM1/ABM2 = 23.67 dB

ABM1 comp = -9.84 dBA/m

BWC Factor = 0.16 dB

Location: -4.2, -8.3, 3.7 mm

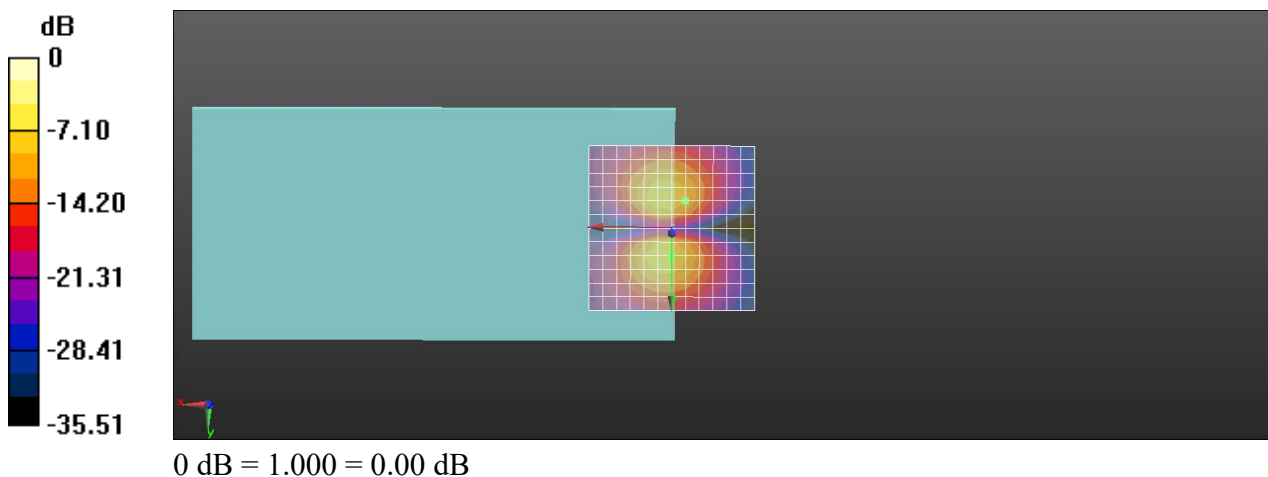

Test Laboratory: SGS-SAR Lab

U693CL HAC-T-Coil-LTE Band 41 20M QPSK 1RB0 40620CH

DUT: U693CL; Type: Smartphone; Serial: 99001565000134

Communication System: UID 0, LTE-TDD BW 20MHz (0); Frequency: 2593 MHz;Duty Cycle: 1:1.57906

Medium: Air;Medium parameters used: $\sigma = 0$ S/m, $\epsilon_r = 1$; $\rho = 0$ kg/m³
Phantom section: TCoil Section

DASY 5 Configuration:

- Probe: AM1DV3 - 3115; ; Calibrated: 2019-06-14
- Sensor-Surface: 0mm (Fix Surface)
- Electronics: DAE4 Sn896; Calibrated: 2019-09-18
- Phantom: HAC Test Arch with AMCC; Type: SD HAC P01 BA;
- DASY52 52.8.8(1222); SEMCAD X 14.6.10(7331)

T-Coil scan/General Scans/z (axial) 4.2mm 50 x 50/ABM SNR(x,y,z) (13x13x1):

Measurement grid: dx=10mm, dy=10mm

ABM1/ABM2 = 34.61 dB

ABM1 comp = 6.50 dBA/m

BWC Factor = 0.16 dB

Location: 0, 0, 3.7 mm

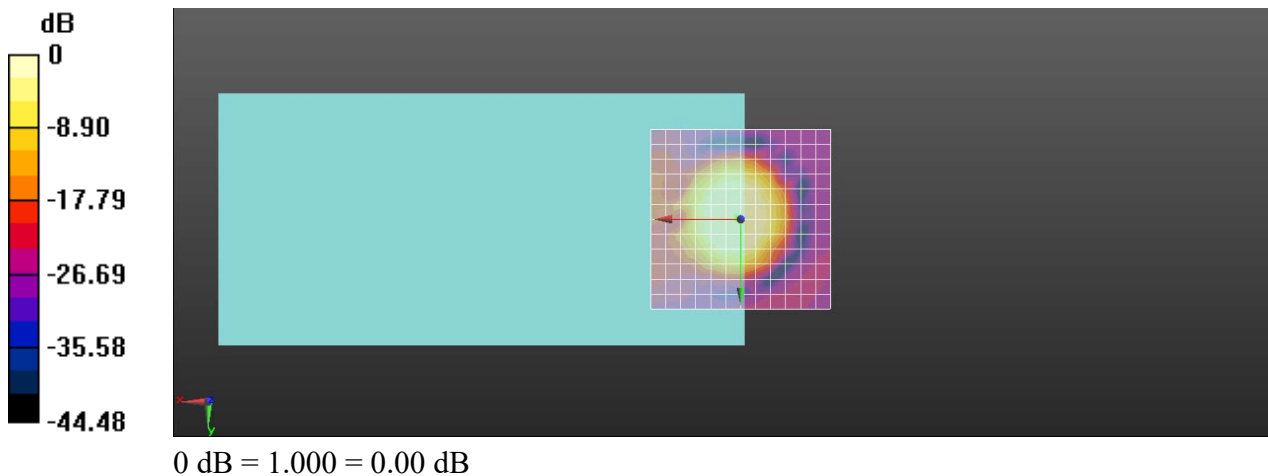

General Scans/z (axial) wideband at best S/N/ABM Freq Resp(x,y,z,f)

Loc: 0.8, -0.3, 3.7 mm Diff: 1.2dB

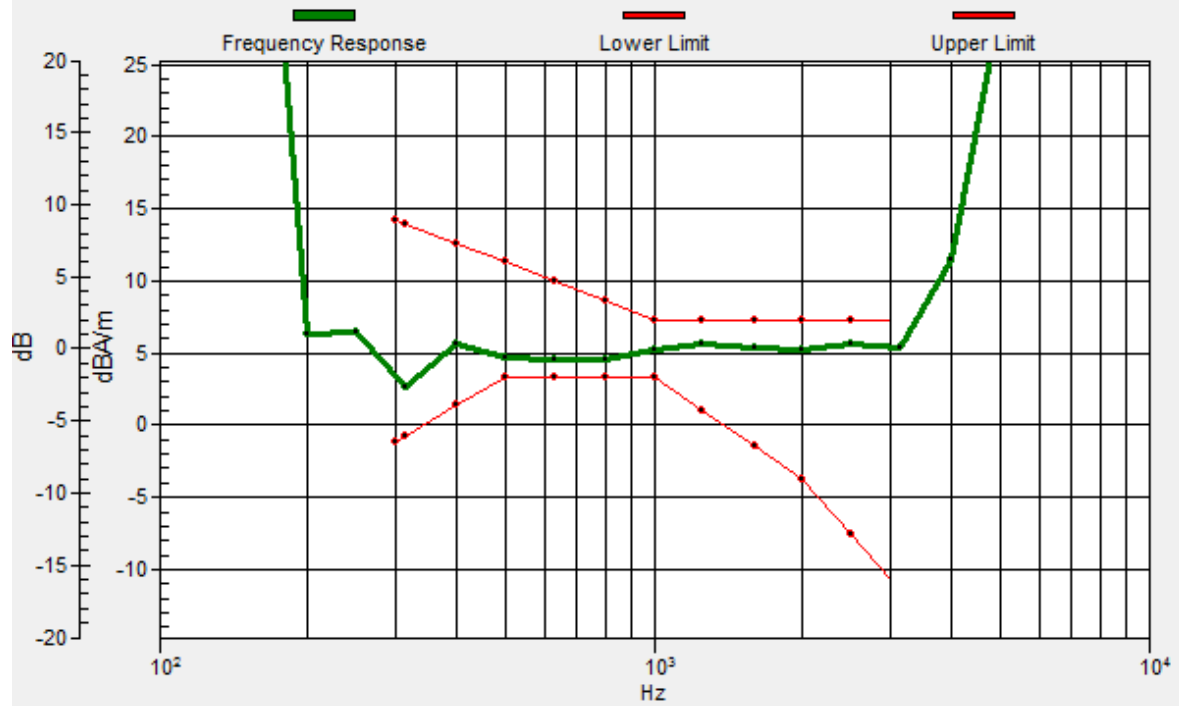

Test Laboratory: SGS-SAR Lab

U693CL HAC-T-Coil-LTE Band 41 20M QPSK 1RB0 40620CH

DUT: U693CL; Type: Smartphone; Serial: 99001565000134

Communication System: UID 0, LTE-TDD BW 20MHz (0); Frequency: 2593 MHz;Duty Cycle: 1:1.57906

Medium: Air;Medium parameters used: $\sigma = 0$ S/m, $\epsilon_r = 1$; $\rho = 0$ kg/m³

Phantom section: TCoil Section

DASY 5 Configuration:

- Probe: AM1DV3 - 3115; ; Calibrated: 2019-06-14
- Sensor-Surface: 0mm (Fix Surface)
- Electronics: DAE4 Sn896; Calibrated: 2019-09-18
- Phantom: HAC Test Arch with AMCC; Type: SD HAC P01 BA;
- DASY52 52.8.8(1222); SEMCAD X 14.6.10(7331)

T-Coil scan/General Scans/y (transversal) 4.2mm 50 x 50/ABM SNR(x,y,z)

(13x13x1): Measurement grid: dx=10mm, dy=10mm

ABM1/ABM2 = 33.71 dB

ABM1 comp = -2.32 dBA/m

BWC Factor = 0.16 dB

Location: 0, -8.3, 3.7 mm

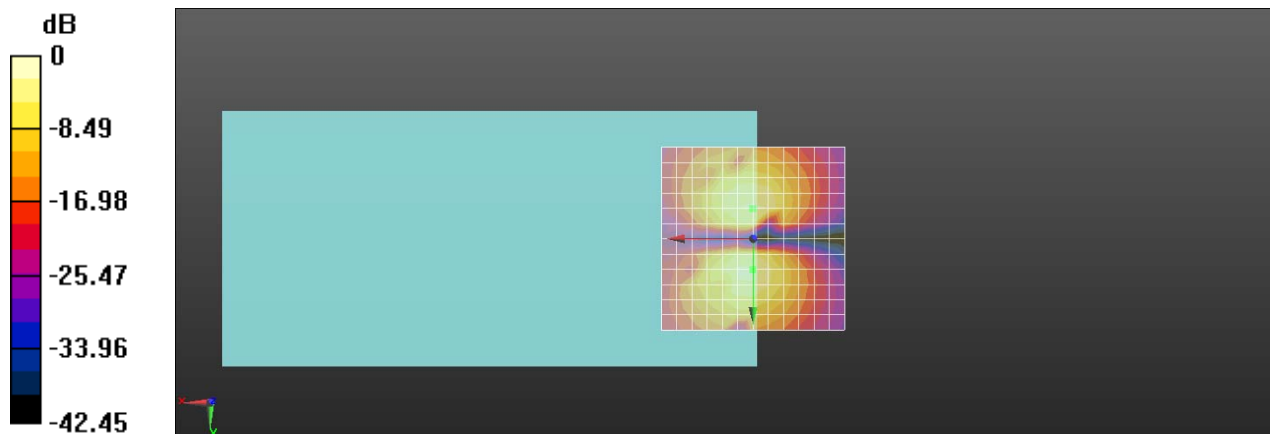

0 dB = 1.000 = 0.00 dB

Test Laboratory: SGS-SAR Lab

U693CL HAC-T-Coil-WiFi 2.4G 802.11b 6CH

DUT: U693CL; Type: Smartphone; Serial: 99001565000134

Communication System: UID 0, WI-FI(2.4GHz) (0); Frequency: 2437 MHz;Duty Cycle: 1:1

Medium: Air;Medium parameters used: $\sigma = 0$ S/m, $\epsilon_r = 1$; $\rho = 0$ kg/m³
Phantom section: TCoil Section

DASY 5 Configuration:

- Probe: AM1DV3 - 3115; ; Calibrated: 2019-06-14
- Sensor-Surface: 0mm (Fix Surface)
- Electronics: DAE4 Sn896; Calibrated: 2019-09-18
- Phantom: HAC Test Arch with AMCC; Type: SD HAC P01 BA;
- DASY52 52.8.8(1222); SEMCAD X 14.6.10(7331)

T-Coil scan/General Scans/z (axial) 4.2mm 50 x 50/ABM SNR(x,y,z) (13x13x1):

Measurement grid: dx=10mm, dy=10mm

ABM1/ABM2 = 30.17 dB

ABM1 comp = 3.74 dBA/m

BWC Factor = 0.16 dB

Location: 0, 0, 3.7 mm

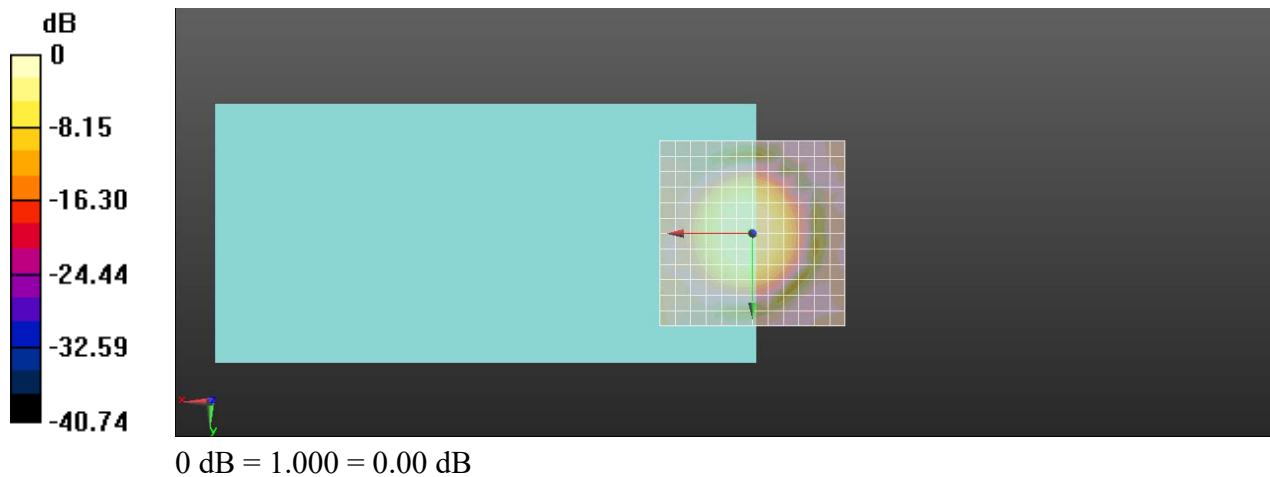

General Scans/z (axial) wideband at best S/N/ABM Freq Resp(x,y,z,f)

Loc: 0.5, -0.5, 3.7 mm Diff: 2dB

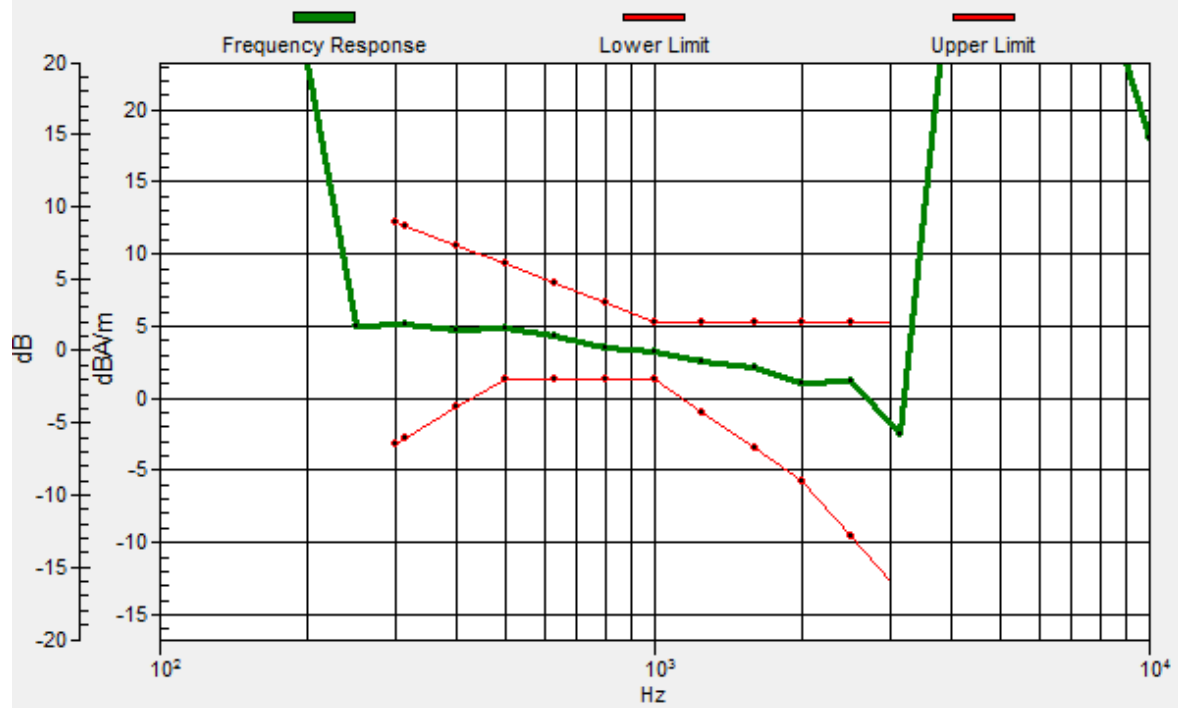

Test Laboratory: SGS-SAR Lab

U693CL HAC-T-Coil-WiFi 2.4G 802.11b 6CH

DUT: U693CL; Type: Smartphone; Serial: 99001565000134

Communication System: UID 0, WI-FI(2.4GHz) (0); Frequency: 2437 MHz;Duty Cycle: 1:1

Medium: Air;Medium parameters used: $\sigma = 0$ S/m, $\epsilon_r = 1$; $\rho = 0$ kg/m³
Phantom section: TCoil Section

DASY 5 Configuration:

- Probe: AM1DV3 - 3115; ; Calibrated: 2019-06-14
- Sensor-Surface: 0mm (Fix Surface)
- Electronics: DAE4 Sn896; Calibrated: 2019-09-18
- Phantom: HAC Test Arch with AMCC; Type: SD HAC P01 BA;
- DASY52 52.8.8(1222); SEMCAD X 14.6.10(7331)

T-Coil scan/General Scans/y (transversal) 4.2mm 50 x 50/ABM SNR(x,y,z)

(13x13x1): Measurement grid: dx=10mm, dy=10mm

ABM1/ABM2 = 29.41 dB

ABM1 comp = -4.95 dBA/m

BWC Factor = 0.16 dB

Location: 0, -8.3, 3.7 mm

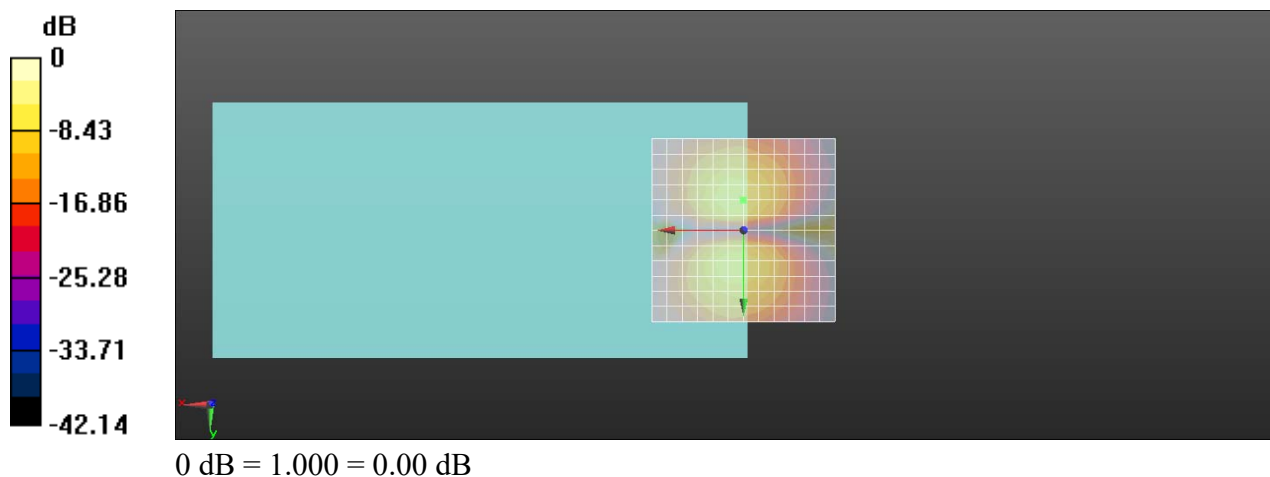

Test Laboratory: SGS-SAR Lab

U693CL HAC-T-Coil-WiFi 2.4G 802.11b 6CH

DUT: U693CL; Type: Smartphone; Serial: 99001565000191

Communication System: UID 0, WI-FI(2.4GHz) (0); Frequency: 2437 MHz;Duty Cycle: 1:1

Medium: Air;Medium parameters used: $\sigma = 0$ S/m, $\epsilon_r = 1$; $\rho = 0$ kg/m³
Phantom section: TCoil Section

DASY 5 Configuration:

- Probe: AM1DV3 - 3115; ; Calibrated: 2019-06-14
- Sensor-Surface: 0mm (Fix Surface)
- Electronics: DAE4 Sn896; Calibrated: 2019-09-18
- Phantom: HAC Test Arch with AMCC; Type: SD HAC P01 BA;
- DASY52 52.8.8(1222); SEMCAD X 14.6.10(7331)

T-Coil scan/General Scans/z (axial) 4.2mm 50 x 50/ABM SNR(x,y,z) (13x13x1):

Measurement grid: dx=10mm, dy=10mm

ABM1/ABM2 = 33.45 dB

ABM1 comp = 4.02 dBA/m

BWC Factor = 0.16 dB

Location: -4.2, -4.2, 3.7 mm

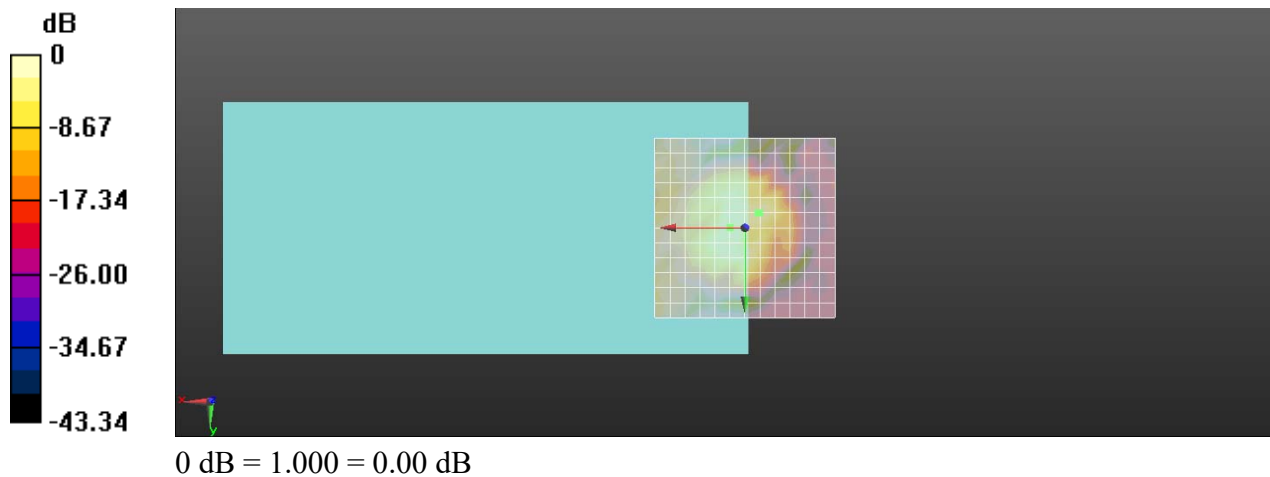

General Scans/z (axial) wideband at best S/N/ABM Freq Resp(x,y,z,f)

Loc: -3.6, -4.2, 3.7 mm Diff: 0.71dB

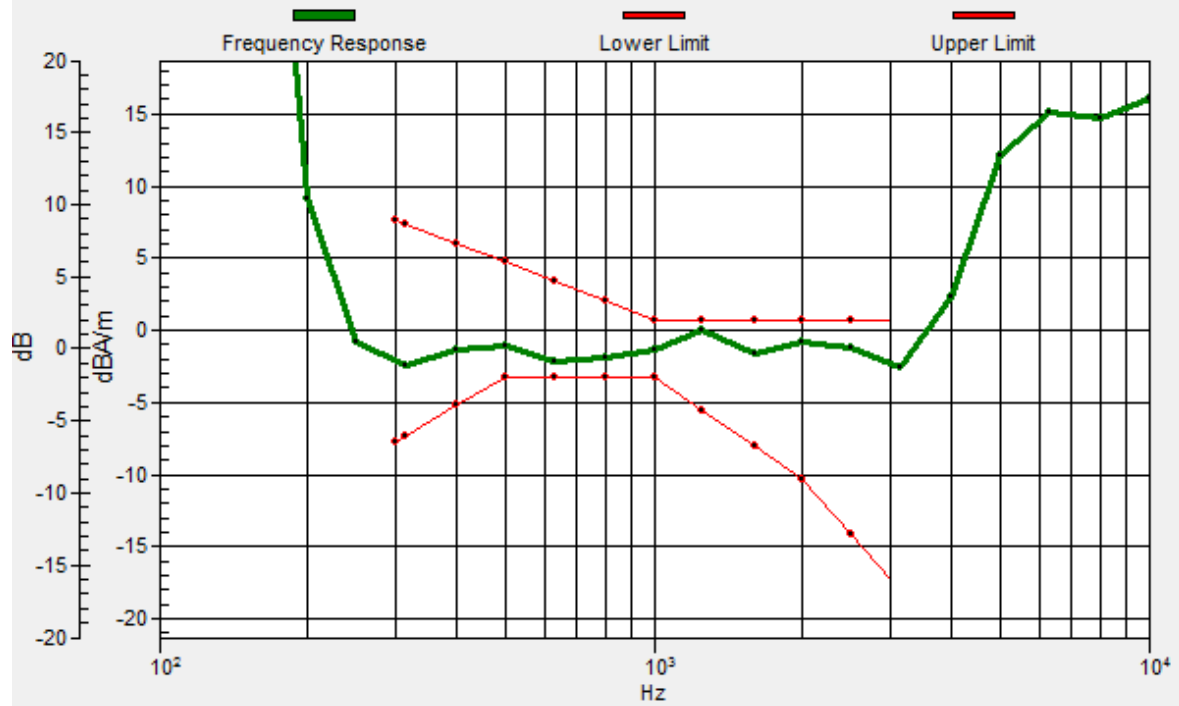

Test Laboratory: SGS-SAR Lab

U693CL HAC-T-Coil-WiFi 2.4G 802.11b 6CH

DUT: U693CL; Type: Smartphone; Serial: 99001565000191

Communication System: UID 0, WI-FI(2.4GHz) (0); Frequency: 2437 MHz;Duty Cycle: 1:1

Medium: Air;Medium parameters used: $\sigma = 0$ S/m, $\epsilon_r = 1$; $\rho = 0$ kg/m³
Phantom section: TCoil Section

DASY 5 Configuration:

- Probe: AM1DV3 - 3115; ; Calibrated: 2019-06-14
- Sensor-Surface: 0mm (Fix Surface)
- Electronics: DAE4 Sn896; Calibrated: 2019-09-18
- Phantom: HAC Test Arch with AMCC; Type: SD HAC P01 BA;
- DASY52 52.8.8(1222); SEMCAD X 14.6.10(7331)

T-Coil scan/General Scans/y (transversal) 4.2mm 50 x 50/ABM SNR(x,y,z)

(13x13x1): Measurement grid: dx=10mm, dy=10mm

ABM1/ABM2 = 31.90 dB

ABM1 comp = -3.30 dBA/m

BWC Factor = 0.16 dB

Location: 4.2, -8.3, 3.7 mm

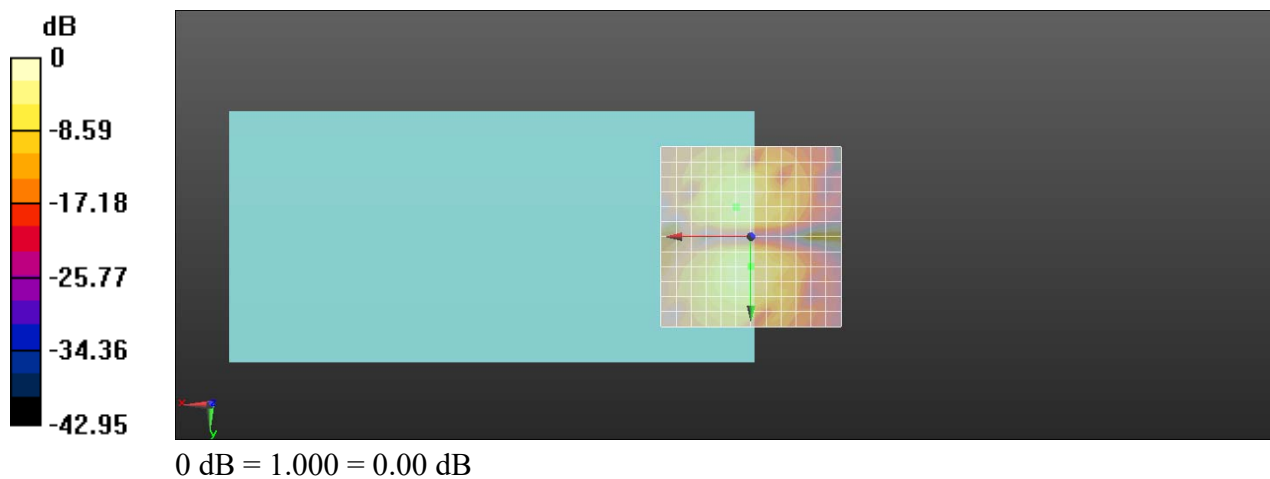



Appendix B

Calibration certificate

1. DAE
DAE4-SN 896(2019-09-11)
2. Probe
AM1DV3-SN 3115(2019-06-14)



Accredited by the Swiss Accreditation Service (SAS)
The Swiss Accreditation Service is one of the signatories to the EA
Multilateral Agreement for the recognition of calibration certificates

Accreditation No.: **SCS 0108**

Client **SGS - CN (Auden)**

Certificate No: **DAE4-896_Sep19**

CALIBRATION CERTIFICATE

Object **DAE4 - SD 000 D04 BJ - SN: 896**

Calibration procedure(s) **QA CAL-06.v29
Calibration procedure for the data acquisition electronics (DAE)**

Calibration date: **September 18, 2019**

This calibration certificate documents the traceability to national standards, which realize the physical units of measurements (SI).
The measurements and the uncertainties with confidence probability are given on the following pages and are part of the certificate.

All calibrations have been conducted in the closed laboratory facility: environment temperature (22 ± 3)°C and humidity < 70%.

Calibration Equipment used (M&TE critical for calibration)

Primary Standards	ID #	Cal Date (Certificate No.)	Scheduled Calibration
Keithley Multimeter Type 2001	SN: 0810278	03-Sep-19 (No:25949)	Sep-20
Secondary Standards	ID #	Check Date (in house)	Scheduled Check
Auto DAE Calibration Unit	SE UWS 053 AA 1001	07-Jan-19 (in house check)	In house check: Jan-20
Calibrator Box V2.1	SE UMS 006 AA 1002	07-Jan-19 (in house check)	In house check: Jan-20

Calibrated by:

Name	Function	Signature
Dominique Steffen	Laboratory Technician	

Approved by:

Sven Kühn	Deputy Manager	
-----------	----------------	--

Issued: September 18, 2019

This calibration certificate shall not be reproduced except in full without written approval of the laboratory.



Accredited by the Swiss Accreditation Service (SAS)

The Swiss Accreditation Service is one of the signatories to the EA
Multilateral Agreement for the recognition of calibration certificates

Accreditation No.: **SCS 0108**

Glossary

DAE data acquisition electronics
Connector angle information used in DASY system to align probe sensor X to the robot coordinate system.

Methods Applied and Interpretation of Parameters

- *DC Voltage Measurement:* Calibration Factor assessed for use in DASY system by comparison with a calibrated instrument traceable to national standards. The figure given corresponds to the full scale range of the voltmeter in the respective range.
- *Connector angle:* The angle of the connector is assessed measuring the angle mechanically by a tool inserted. Uncertainty is not required.
- The following parameters as documented in the Appendix contain technical information as a result from the performance test and require no uncertainty.
 - *DC Voltage Measurement Linearity:* Verification of the Linearity at +10% and -10% of the nominal calibration voltage. Influence of offset voltage is included in this measurement.
 - *Common mode sensitivity:* Influence of a positive or negative common mode voltage on the differential measurement.
 - *Channel separation:* Influence of a voltage on the neighbor channels not subject to an input voltage.
 - *AD Converter Values with inputs shorted:* Values on the internal AD converter corresponding to zero input voltage
 - *Input Offset Measurement:* Output voltage and statistical results over a large number of zero voltage measurements.
 - *Input Offset Current:* Typical value for information; Maximum channel input offset current, not considering the input resistance.
 - *Input resistance:* Typical value for information: DAE input resistance at the connector, during internal auto-zeroing and during measurement.
 - *Low Battery Alarm Voltage:* Typical value for information. Below this voltage, a battery alarm signal is generated.
 - *Power consumption:* Typical value for information. Supply currents in various operating modes.

DC Voltage Measurement

A/D - Converter Resolution nominal

High Range: 1LSB = 6.1 μ V, full range = -100...+300 mV
Low Range: 1LSB = 61nV, full range = -1.....+3mV

DASY measurement parameters: Auto Zero Time: 3 sec; Measuring time: 3 sec

Calibration Factors	X	Y	Z
High Range	404.022 \pm 0.02% (k=2)	404.257 \pm 0.02% (k=2)	404.191 \pm 0.02% (k=2)
Low Range	3.98013 \pm 1.50% (k=2)	3.99657 \pm 1.50% (k=2)	3.97235 \pm 1.50% (k=2)

Connector Angle

Connector Angle to be used in DASY system	37.5 $^{\circ}$ \pm 1 $^{\circ}$
---	------------------------------------

Appendix (Additional assessments outside the scope of SCS0108)

1. DC Voltage Linearity

High Range	Reading (μV)	Difference (μV)	Error (%)
Channel X + Input	200040.89	5.76	0.00
Channel X + Input	20006.10	0.48	0.00
Channel X - Input	-20002.92	2.55	-0.01
Channel Y + Input	200032.08	-3.21	-0.00
Channel Y + Input	20004.20	-1.29	-0.01
Channel Y - Input	-20004.09	1.52	-0.01
Channel Z + Input	200033.60	-1.56	-0.00
Channel Z + Input	20003.49	-2.00	-0.01
Channel Z - Input	-20004.81	0.85	-0.00

Low Range	Reading (μV)	Difference (μV)	Error (%)
Channel X + Input	2000.63	-0.76	-0.04
Channel X + Input	201.08	-0.29	-0.15
Channel X - Input	-199.07	-0.39	0.20
Channel Y + Input	2001.55	0.25	0.01
Channel Y + Input	199.66	-1.59	-0.79
Channel Y - Input	-199.65	-0.88	0.45
Channel Z + Input	2001.32	0.14	0.01
Channel Z + Input	200.72	-0.51	-0.25
Channel Z - Input	-200.26	-1.43	0.72

2. Common mode sensitivity

DASY measurement parameters: Auto Zero Time: 3 sec; Measuring time: 3 sec

	Common mode Input Voltage (mV)	High Range Average Reading (μV)	Low Range Average Reading (μV)
Channel X	200	11.76	10.55
	- 200	-10.27	-11.69
Channel Y	200	15.87	16.13
	- 200	-17.91	-18.33
Channel Z	200	5.47	5.16
	- 200	-7.23	-6.76

3. Channel separation

DASY measurement parameters: Auto Zero Time: 3 sec; Measuring time: 3 sec

	Input Voltage (mV)	Channel X (μV)	Channel Y (μV)	Channel Z (μV)
Channel X	200	-	-0.54	-4.17
Channel Y	200	7.56	-	0.46
Channel Z	200	9.61	5.52	-

4. AD-Converter Values with inputs shorted

DASY measurement parameters: Auto Zero Time: 3 sec; Measuring time: 3 sec

	High Range (LSB)	Low Range (LSB)
Channel X	15562	17474
Channel Y	15992	17482
Channel Z	15642	14726

5. Input Offset Measurement

DASY measurement parameters: Auto Zero Time: 3 sec; Measuring time: 3 sec

Input 10MΩ

	Average (μV)	min. Offset (μV)	max. Offset (μV)	Std. Deviation (μV)
Channel X	0.71	-0.23	2.09	0.45
Channel Y	-0.40	-1.78	0.63	0.55
Channel Z	-0.76	-1.83	0.29	0.47

6. Input Offset Current

Nominal Input circuitry offset current on all channels: <25fA

7. Input Resistance (Typical values for information)

	Zeroing (kOhm)	Measuring (MOhm)
Channel X	200	200
Channel Y	200	200
Channel Z	200	200

8. Low Battery Alarm Voltage (Typical values for information)

Typical values	Alarm Level (VDC)
Supply (+ Vcc)	+7.9
Supply (- Vcc)	-7.6

9. Power Consumption (Typical values for information)

Typical values	Switched off (mA)	Stand by (mA)	Transmitting (mA)
Supply (+ Vcc)	+0.01	+6	+14
Supply (- Vcc)	-0.01	-8	-9

IMPORTANT NOTICE

USAGE OF THE DAE4

The DAE unit is a delicate, high precision instrument and requires careful treatment by the user. There are no serviceable parts inside the DAE. Special attention shall be given to the following points:

Battery Exchange: The battery cover of the DAE4 unit is fixed using a screw, over tightening the screw may cause the threads inside the DAE to wear out.

Shipping of the DAE: Before shipping the DAE to SPEAG for calibration, remove the batteries and pack the DAE in an antistatic bag. This antistatic bag shall then be packed into a larger box or container which protects the DAE from impacts during transportation. The package shall be marked to indicate that a fragile instrument is inside.

E-Stop Failures: Touch detection may be malfunctioning due to broken magnets in the E-stop. Rough handling of the E-stop may lead to damage of these magnets. Touch and collision errors are often caused by dust and dirt accumulated in the E-stop. To prevent E-stop failure, the customer shall always mount the probe to the DAE carefully and keep the DAE unit in a non-dusty environment if not used for measurements.

Repair: Minor repairs are performed at no extra cost during the annual calibration. However, SPEAG reserves the right to charge for any repair especially if rough unprofessional handling caused the defect.

DASY Configuration Files: Since the exact values of the DAE input resistances, as measured during the calibration procedure of a DAE unit, are not used by the DASY software, a nominal value of 200 MOhm is given in the corresponding configuration file.

Important Note:

Warranty and calibration is void if the DAE unit is disassembled partly or fully by the Customer.

Important Note:

Never attempt to grease or oil the E-stop assembly. Cleaning and readjusting of the E-stop assembly is allowed by certified SPEAG personnel only and is part of the annual calibration procedure.

Important Note:

To prevent damage of the DAE probe connector pins, use great care when installing the probe to the DAE. Carefully connect the probe with the connector notch oriented in the mating position. Avoid any rotational movement of the probe body versus the DAE while turning the locking nut of the connector. The same care shall be used when disconnecting the probe from the DAE.



Accredited by the Swiss Accreditation Service (SAS)
The Swiss Accreditation Service is one of the signatories to the EA
Multilateral Agreement for the recognition of calibration certificates

Accreditation No.: **SCS 0108**

Client **SGS-TW (Auden)**

Certificate No: **AM1DV3-3115_Jun19**

CALIBRATION CERTIFICATE

Object **AM1DV3 - SN: 3115**

Calibration procedure(s) **QA CAL-24.v4
Calibration procedure for AM1D magnetic field probes and TMFS in the
audio range**

Calibration date: **June 14, 2019**

This calibration certificate documents the traceability to national standards, which realize the physical units of measurements (SI).
The measurements and the uncertainties with confidence probability are given on the following pages and are part of the certificate.

All calibrations have been conducted in the closed laboratory facility: environment temperature $(22 \pm 3)^\circ\text{C}$ and humidity $< 70\%$.

Calibration Equipment used (M&TE critical for calibration)

Primary Standards	ID #	Cal Date (Certificate No.)	Scheduled Calibration
Keithley Multimeter Type 2001	SN: 0810278	03-Sep-18 (No. 23488)	Sep-19
Reference Probe AM1DV2	SN: 1008	20-Dec-18 (No. AM1DV2-1008_Dec18)	Dec-19
DAE4	SN: 781	09-Jan-19 (No. DAE4-781_Jan19)	Jan-20
Secondary Standards	ID #	Check Date (in house)	Scheduled Check
AMCC	SN: 1050	01-Oct-13 (in house check Oct-17)	Oct-19
AMMI Audio Measuring Instrument	SN: 1062	26-Sep-12 (in house check Oct-17)	Oct-19

Calibrated by: **Name** Claudio Leubler **Function** Laboratory Technician

Signature

Approved by: **Name** Katja Pokovic **Function** Technical Manager

Issued: June 14, 2019

This calibration certificate shall not be reproduced except in full without written approval of the laboratory.

[References

- [1] ANSI-C63.19-2007
American National Standard for Methods of Measurement of Compatibility between Wireless Communications Devices and Hearing Aids.
- [2] ANSI-C63.19-2011
American National Standard, Methods of Measurement of Compatibility between Wireless Communications Devices and Hearing Aids.
- [3] DASY5 manual, Chapter: Hearing Aid Compatibility (HAC) T-Coil Extension

Description of the AM1D probe

The AM1D Audio Magnetic Field Probe is a fully shielded magnetic field probe for the frequency range from 100 Hz to 20 kHz. The pickup coil is compliant with the dimensional requirements of [1+2]. The probe includes a symmetric low noise amplifier for the signal available at the shielded 3 pin connector at the side. Power is supplied via the same connector (phantom power supply) and monitored via the LED near the connector. The 7 pin connector at the end of the probe does not carry any signals, but determines the angle of the sensor when mounted on the DAE. The probe supports mechanical detection of the surface.

The single sensor in the probe is arranged in a tilt angle allowing measurement of 3 orthogonal field components when rotating the probe by 120° around its axis. It is aligned with the perpendicular component of the field, if the probe axis is tilted nominally 35.3° above the measurement plane, using the connector rotation and sensor angle stated below.

The probe is fully RF shielded when operated with the matching signal cable (shielded) and allows measurement of audio magnetic fields in the close vicinity of RF emitting wireless devices according to [1+2] without additional shielding.

Handling of the item

The probe is manufactured from stainless steel. In order to maintain the performance and calibration of the probe, it must not be opened. The probe is designed for operation in air and shall not be exposed to humidity or liquids. For proper operation of the surface detection and emergency stop functions in a DASY system, the probe must be operated with the special probe cup provided (larger diameter).

Methods Applied and Interpretation of Parameters

- *Coordinate System:* The AM1D probe is mounted in the DASY system for operation with a HAC Test Arch phantom with AMCC Helmholtz calibration coil according to [3], with the tip pointing to “southwest” orientation.
- *Functional Test:* The functional test preceding calibration includes test of Noise level
RF immunity (1kHz AM modulated signal). The shield of the probe cable must be well connected.
Frequency response verification from 100 Hz to 10 kHz.
- *Connector Rotation:* The connector at the end of the probe does not carry any signals and is used for fixation to the DAE only. The probe is operated in the center of the AMCC Helmholtz coil using a 1 kHz magnetic field signal. Its angle is determined from the two minima at nominally +120° and –120° rotation, so the sensor in the tip of the probe is aligned to the vertical plane in z-direction, corresponding to the field maximum in the AMCC Helmholtz calibration coil.
- *Sensor Angle:* The sensor tilting in the vertical plane from the ideal vertical direction is determined from the two minima at nominally +120° and –120°. DASY system uses this angle to align the sensor for radial measurements to the x and y axis in the horizontal plane.

Sensitivity: With the probe sensor aligned to the z-field in the AMCC, the output of the probe is compared to the magnetic field in the AMCC at 1 kHz. The field in the AMCC Helmholtz coil is given by the geometry and the current through the coil, which is monitored on the precision shunt resistor of the coil.

AM1D probe identification and configuration data

Item	AM1DV3 Audio Magnetic 1D Field Probe
Type No	SP AM1 001 BB
Serial No	3115

Overall length	296 mm
Tip diameter	6.0 mm (at the tip)
Sensor offset	3.0 mm (centre of sensor from tip)
Internal Amplifier	20 dB

Manufacturer / Origin	Schmid & Partner Engineering AG, Zurich, Switzerland
-----------------------	--

Calibration data

Connector rotation angle	(in DASY system)	259.3 °	+/- 3.6 ° (k=2)
Sensor angle	(in DASY system)	0.24 °	+/- 0.5 ° (k=2)
Sensitivity at 1 kHz	(in DASY system)	0.00791 V/(A/m)	+/- 2.2 % (k=2)

The reported uncertainty of measurement is stated as the standard uncertainty of measurement multiplied by the coverage factor $k=2$, which for a normal distribution corresponds to a coverage probability of approximately 95%.



Appendix C

Photographs

1. SAR measurement System
2. Photographs of EUT test position
3. EUT Constructional Details

1 SAR measurement System



2 Photographs of Test Setup

Photo 1: Receiver of mobile contact center of Arch

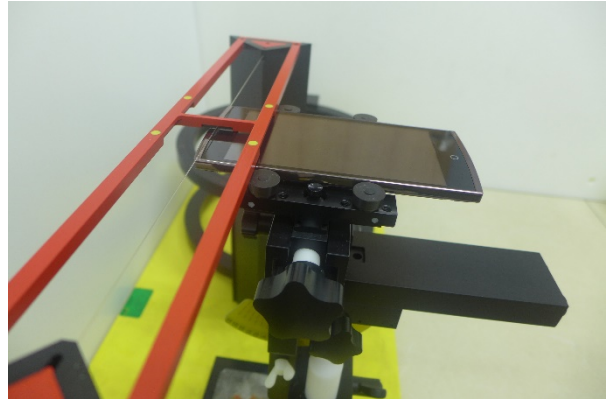
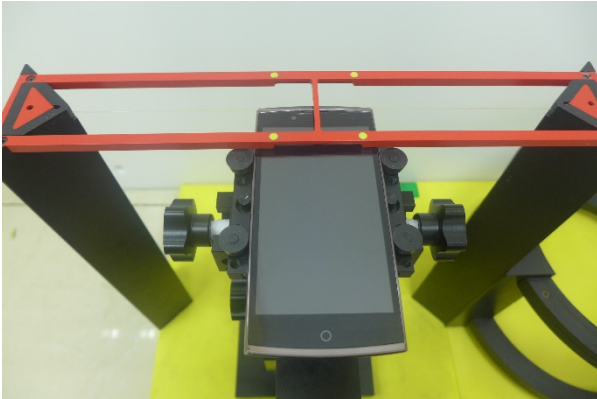

3 Photographs of the EUT

Photo 2: Front View



Photo 3: Back View

