

FCC RF Test Report

APPLICANT : Unimax Communications
EQUIPMENT : CDMA EVDO REV A 800/1900MHz mobile phone
BRAND NAME : UMX
MODEL NAME : U680
FCC ID : P46-U680
STANDARD : FCC Part 15 Subpart C §15.247
CLASSIFICATION : (DTS) Digital Transmission System

The product was received on Dec. 11, 2012 and completely tested on Jan. 08, 2013. We, SPORTON INTERNATIONAL (KUNSHAN) INC., would like to declare that the tested sample has been evaluated in accordance with the procedures and shown the compliance with the applicable technical standards.

The test results in this report apply exclusively to the tested model / sample. Without written approval of SPORTON INTERNATIONAL (KUNSHAN) INC., the test report shall not be reproduced except in full.

Reviewed by:



Jones Tsai / Manager



SPORTON INTERNATIONAL (KUNSHAN) INC.
No. 3-2, PingXiang Road, Kunshan, Jiangsu Province, P.R.C.



TABLE OF CONTENTS

REVISION HISTORY..... 3

SUMMARY OF TEST RESULT 4

1 GENERAL DESCRIPTION 5

 1.1 Applicant..... 5

 1.2 Manufacturer..... 5

 1.3 Feature of Equipment Under Test 5

 1.4 Product Specification of Equipment Under Test..... 5

 1.5 Testing Site..... 6

 1.6 Applied Standards 6

2 TEST CONFIGURATION OF EQUIPMENT UNDER TEST 7

 2.1 Carrier Frequency Channel 7

 2.2 Pre-Scanned RF Power..... 8

 2.3 Test Mode..... 9

 2.4 Connection Diagram of Test System..... 10

 2.5 Support Unit used in test configuration and system 11

 2.6 RF Utility 11

 2.7 Measurement Results Explanation Example..... 12

3 TEST RESULT..... 13

 3.1 6dB and 99% Bandwidth Measurement 13

 3.2 Output Power Measurement..... 26

 3.3 Power Spectral Density Measurement 29

 3.4 Conducted Band Edges and Spurious Emission Measurement 43

 3.5 Radiated Emission Measurement..... 56

 3.6 AC Conducted Emission Measurement..... 74

 3.7 Antenna Requirements..... 78

4 LIST OF MEASURING EQUIPMENT 79

5 UNCERTAINTY OF EVALUATION 80

APPENDIX A. PHOTOGRAPHS OF EUT

APPENDIX B. SETUP PHOTOGRAPHS

SUMMARY OF TEST RESULT

Report Section	FCC Rule	IC Rule	Description	Limit	Result	Remark
3.1	15.247(a)(2)	A8.2(a)	6dB Bandwidth	$\geq 0.5\text{MHz}$	Pass	-
3.1	-	Gen 4.6.1	99% Bandwidth	-	Pass	-
3.2	15.247(b)	A8.4	Power Output Measurement	$\leq 30\text{dBm}$	Pass	-
3.3	15.247(e)	A8.2(b)	Power Spectral Density	$\leq 8\text{dBm}/3\text{kHz}$	Pass	-
3.4	15.247(d)	A8.5	Conducted Band Edges	$\leq 20\text{dBc}$	Pass	-
			Conducted Spurious Emission		Pass	-
3.5	15.247(d)	A8.5	Radiated Band Edges	15.209(a) & 15.247(d)	Pass	-
			Radiated Spurious Emission		Pass	Under limit 4.73 dB at 2399.000 MHz
3.6	15.207	Gen 7.2.4	AC Conducted Emission	15.207(a)	Pass	Under limit 7.22 dB at 1.220 MHz
3.7	15.203 & 15.247(b)	A8.4	Antenna Requirement	N/A	Pass	-



1 General Description

1.1 Applicant

Unimax Communications
18201 McDermott St. West Suite E, Irvine, CA 92614

1.2 Manufacturer

Unimax Communications
18201 McDermott St. West Suite E, Irvine, CA 92614

1.3 Feature of Equipment Under Test

Product Feature	
Equipment	CDMA EVDO REV A 800/1900MHz mobile phone
Brand Name	UMX
Model Name	U680
FCC ID	P46-U680
EUT supports Radios application	CDMA/EV-DO/WLAN 11bgn/Bluetooth3.0 EDR
HW Version	G3616_V1.1
SW Version	U680_05.03
EUT Stage	Identical Prototype

Remark:

1. The above EUT's information was declared by manufacturer. Please refer to the specifications or user's manual for more detailed description.
2. There are two different types of EUT that only with different logo in the front. The others are the same including circuit design, PCB board, structure and all components. It is special to declare.

1.4 Product Specification of Equipment Under Test

Product Specification subjective to this standard	
Tx/Rx Frequency Range	2412 MHz ~ 2462 MHz
Number of Channels	11
Carrier Frequency of Each Channel	2412+(n-1)*5 MHz; n=1~11
Maximum Output Power to Antenna	802.11b : 20.61 dBm (0.1151 W) 802.11g : 18.62 dBm (0.0728 W) 802.11n HT20 : 18.51 dBm (0.0710 W)
99% Occupied Bandwidth	802.11b : 18.80MHz 802.11g : 18.00MHz 802.11n HT20 : 19.40MHz
Antenna Type	PIFA Antenna type with gain -1.50 dBi
Type of Modulation	802.11b : DSSS (DBPSK / DQPSK / CCK) 802.11g/n : OFDM (BPSK / QPSK / 16QAM / 64QAM)

1.5 Testing Site

Test Site	SPORTON INTERNATIONAL (KUNSHAN) INC.			
Test Site Location	No. 3-2, PingXiang Road, Kunshan, Jiangsu Province, P.R.C. TEL: +86-0512-5790-0158 FAX: +86-0512-5790-0958			
Test Site No.	Sporton Site No.			FCC/IC Registration No.
	TH01-KS	CO01-KS	03CH01-KS	149928/4086E-1

1.6 Applied Standards

According to the specifications of the manufacturer, the EUT must comply with the requirements of the following standards:

- ♦ FCC Part 15 Subpart C §15.247
- ♦ FCC KDB Publication No. 558074 D01 DTS Meas. Guidance v02
- ♦ ANSI C63.4-2003 and ANSI C63.10-2009
- ♦ IC RSS-210 Issue 8
- ♦ IC RSS-Gen Issue 3
- ♦ NOTICE 2012-DRS0126

Remark:

1. All test items were verified and recorded according to the standards and without any deviation during the test.
2. This EUT has also been tested and complied with the requirements of FCC Part 15, Subpart B, recorded in a separate test report.
3. Per the section 2.2.3 of Notice of 2012-DRS0126, “ Receivers Excluded from Industry Canada Requirements”, only radio communication receivers operating in stand-alone mode within the band 30-960 MHz and scanner receivers are subject to Industry Canada requirements.

2 Test Configuration of Equipment Under Test

The EUT has been associated with peripherals and configuration operated in a manner tended to maximize its emission characteristics in a typical application. Frequency range investigated: conducted emission (150 KHz to 30 MHz) and radiated emission (9 KHz to the 10th harmonic of the highest fundamental frequency or to 40 GHz, whichever is lower). For radiated measurement, pre-scanned in three orthogonal panels, X, Y, Z. The worst cases (Y plane) were recorded in this report.

The final configuration from all the combinations and the worst-case data rates were investigated by measuring the maximum power across all the data rates and modulation modes under section 2.2.

Based on the worst configuration found above, the RF power setting is set individually to meet FCC compliance limit for the final conducted and radiated tests shown in section 2.3.

2.1 Carrier Frequency Channel

Frequency Band	Channel	Freq. (MHz)	Channel	Freq. (MHz)
2400-2483.5 MHz	1	2412	7	2442
	2	2417	8	2447
	3	2422	9	2452
	4	2427	10	2457
	5	2432	11	2462
	6	2437	-	-

2.2 Pre-Scanned RF Power

Preliminary tests were performed in different data rate and antenna configurations as following table and the highest power data rates were chosen for full test in the following tables. Final Output Power equals to Measured Output Power adds the duty factor.

Channel	Frequency	2.4GHz 802.11b RF Power (dBm)			
		DSSS Data Rate			
		1 Mbps	2 Mbps	5.5 Mbps	11 Mbps
CH 01	2412 MHz	19.68	19.71	19.73	19.72
CH 06	2437 MHz	20.11	20.14	20.13	20.15
CH 11	2462 MHz	20.51	20.55	20.6	20.61

Channel	Frequency	2.4GHz 802.11g RF Power (dBm)							
		OFDM Data Rate							
		6 Mbps	9 Mbps	12 Mbps	18 Mbps	24 Mbps	36 Mbps	48 Mbps	54 Mbps
CH 01	2412 MHz	17.42	16.91	17.73	17.23	17.73	17.31	17.08	17.62
CH 06	2437 MHz	18.22	17.67	18.19	17.63	18.15	17.85	17.81	18.03
CH 11	2462 MHz	18.42	17.89	18.43	17.73	18.62	18.42	17.97	18.22

Channel	Frequency	2.4GHz 802.11n HT20 RF Power (dBm)							
		OFDM Data Rate							
		MCS0	MCS1	MCS2	MCS3	MCS4	MCS5	MCS6	MCS7
CH 01	2412 MHz	17	17.26	17.17	17.63	17.7	17.65	17.79	16.71
CH 06	2437 MHz	17.97	17.74	17.61	17.84	17.93	17.95	17.73	17.05
CH 11	2462 MHz	18.09	18.01	18.51	18.05	18.01	17.92	18.35	17.3

2.3 Test Mode

Final results of test modes, data rates and test channels are shown as following table.

Test Cases				
	Test Items	Mode	Data Rate	Test Channel
Conducted TCs	6dB and 99% BW Power Spectral Density	802.11b	11 Mbps	1/6/11
		802.11g	24 Mbps	1/6/11
		802.11n HT20	19.5 Mbps	1/6/11
	Output Power	802.11b	11 Mbps	1/6/11
		802.11g	24 Mbps	1/6/11
		802.11n HT20	19.5 Mbps	1/6/11
	Conducted Band Edge	802.11b	11 Mbps	1/11
		802.11g	24 Mbps	1/11
		802.11n HT20	19.5 Mbps	1/11
Conducted Spurious Emission	802.11b	11 Mbps	1/6/11	
	802.11g	24 Mbps	1/6/11	
	802.11n HT20	19.5 Mbps	1/6/11	
Radiated TCs	Radiated Band Edge	802.11b	11 Mbps	1/11
		802.11g	24 Mbps	1/11
		802.11n HT20	19.5 Mbps	1/11
	Radiated Spurious Emission	802.11b	11 Mbps	1/6/11
		802.11g	24 Mbps	1/6/11
		802.11n HT20	19.5 Mbps	1/6/11
AC Conducted Emission	Mode 1 : CDMA2000 BC0 Idle + WLAN Link + Bluetooth Link + USB Cable (Charging from Adapter) + Earphone			

2.4 Connection Diagram of Test System

<WLAN Tx Mode>

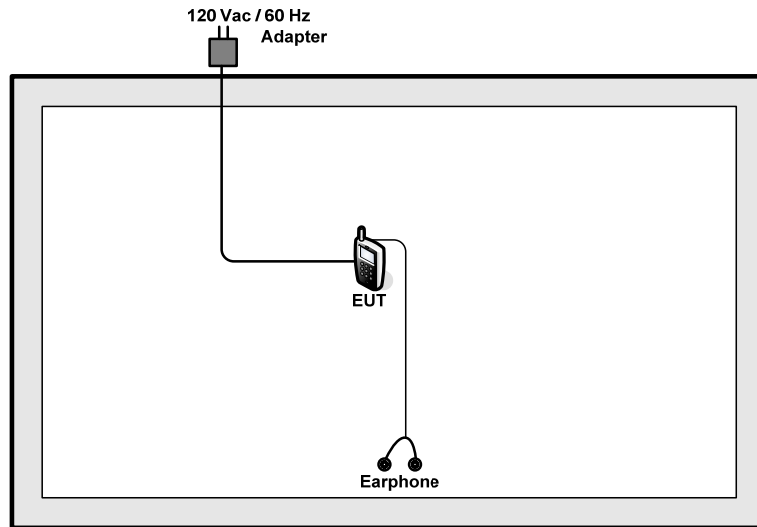

<AC Conducted Emission Mode>

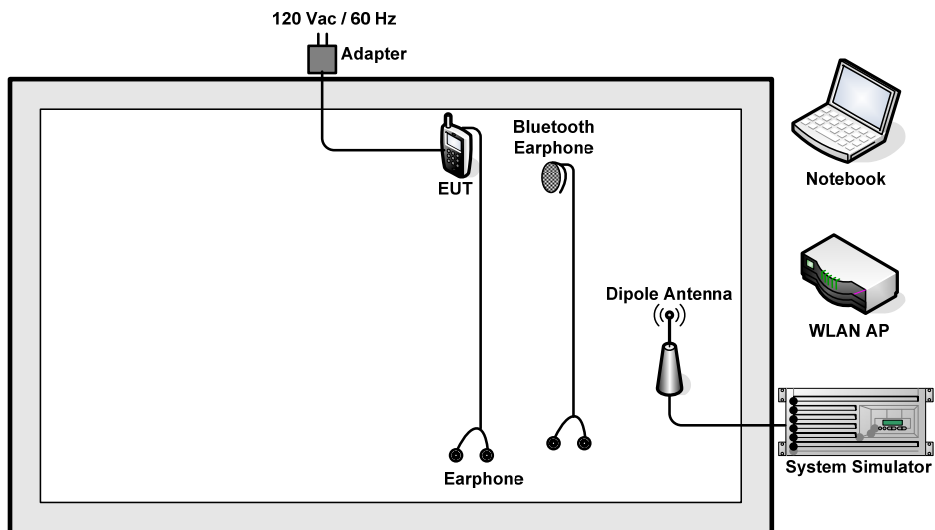

2.5 Support Unit used in test configuration and system

Item	Equipment	Trade Name	Model Name	FCC ID	Data Cable	Power Cord
1.	System Simulator	R&S	CMU 200	N/A	N/A	Unshielded, 1.8 m
2.	DC Power Supply	GWINSTEK	GPS-3030D	N/A	N/A	Unshielded, 1.8 m
3.	WLAN AP	D-Link	DIR-855	KA2DIR855A2	N/A	Unshielded, 1.8 m
4.	Notebook	DELL	P08S	QDS-BRCM1030	N/A	AC I/P: Unshielded, 0.9 m DC O/P: Shielded, 1.8 m
5.	Bluetooth Earphone	Nokia	BH-106	QTLBH-106	N/A	N/A

2.6 RF Utility

For WLAN function, programmed RF utility, “ADB” installed in the EUT make the EUT provides functions like channel selection and power level for continuous transmitting and receiving signals.



2.7 Measurement Results Explanation Example

For conducted test items:

The offset level is set in the spectrum analyzer to compensate the RF cable loss and 10dB attenuator between EUT conducted output port and spectrum analyzer. With the offset compensation, the spectrum analyzer reading level is exactly the EUT RF output level.

The spectrum analyzer offset is derived from RF cable loss and 10dB attenuator factor.

Offset = RF cable loss + attenuator factor.

Following table shows an offset computation example with cable loss 7.50 dB.

Example :

$$\begin{aligned} \text{Offset(dB)} &= \text{RF cable loss(dB)} + \text{attenuator factor(dB)}. \\ &= 7.50 + 10 = 17.50 \text{ (dB)} \end{aligned}$$

3 Test Result

3.1 6dB and 99% Bandwidth Measurement

3.1.1 Limit of 6dB and 99% Bandwidth

The minimum 6 dB bandwidth shall be at least 500 KHz.

3.1.2 Measuring Instruments

See list of measuring instruments of this test report.

3.1.3 Test Procedures

1. The testing follows the Measurement Procedure of FCC KDB No. 558074 DTS D01 Meas. Guidance v02.
2. The RF output of EUT was connected to the spectrum analyzer by RF cable and attenuator. The path loss was compensated to the results for each measurement.
3. Set to the maximum power setting and enable the EUT transmit continuously.
4. Make the measurement with the spectrum analyzer's resolution bandwidth (RBW) = 100 kHz. Set the Video bandwidth (VBW) = 300 kHz. In order to make an accurate measurement. The 6 dB bandwidth must be greater than 500 KHz.
5. For 99% Bandwidth Measurement, the spectrum analyzer's resolution bandwidth (RBW) is set 1MHz and set the Video bandwidth (VBW) = 3MHz.
6. Measure and record the results in the test report.

3.1.4 Test Setup

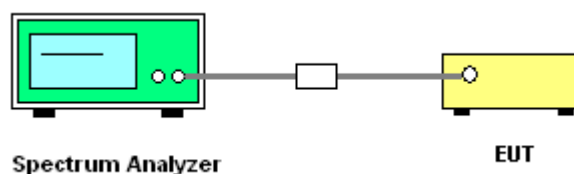

3.1.5 Test Result of 6dB Bandwidth

Test Mode :	802.11b	Temperature :	20~21°C
Test Engineer :	Zhi Lu	Relative Humidity :	40~41%

Channel	Frequency (MHz)	802.11b 6dB Bandwidth (MHz)	6dB Bandwidth Min. Limit (MHz)	Pass/Fail
01	2412	10.08	0.5	Pass
06	2437	10.04	0.5	Pass
11	2462	10.04	0.5	Pass

6 dB Bandwidth Plot on 802.11b Channel 01

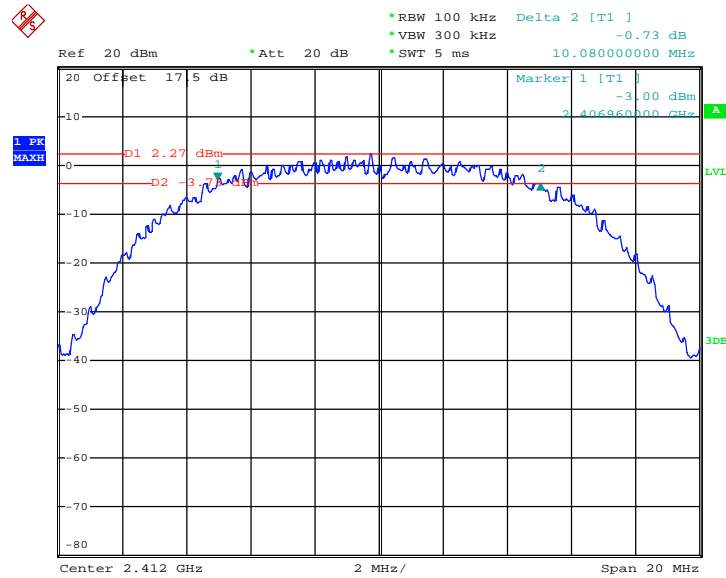

Date: 14.DEC.2012 17:07:41



6 dB Bandwidth Plot on 802.11b Channel 06

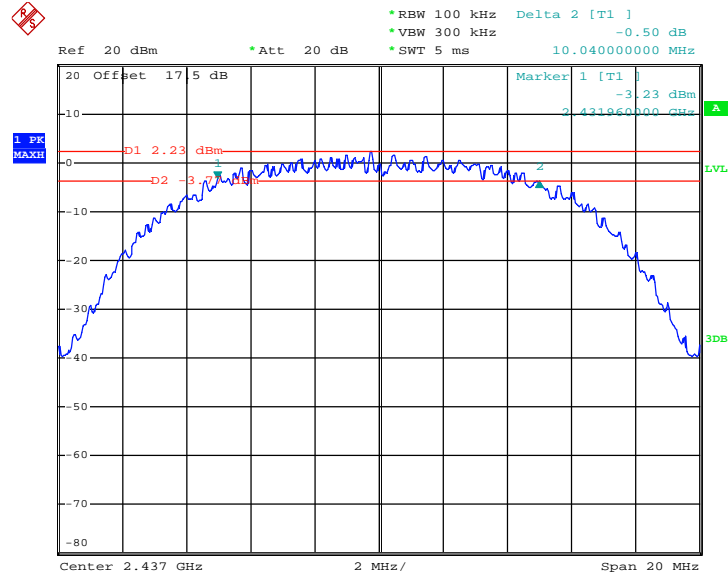

Date: 14.DEC.2012 17:06:02

6 dB Bandwidth Plot on 802.11b Channel 11

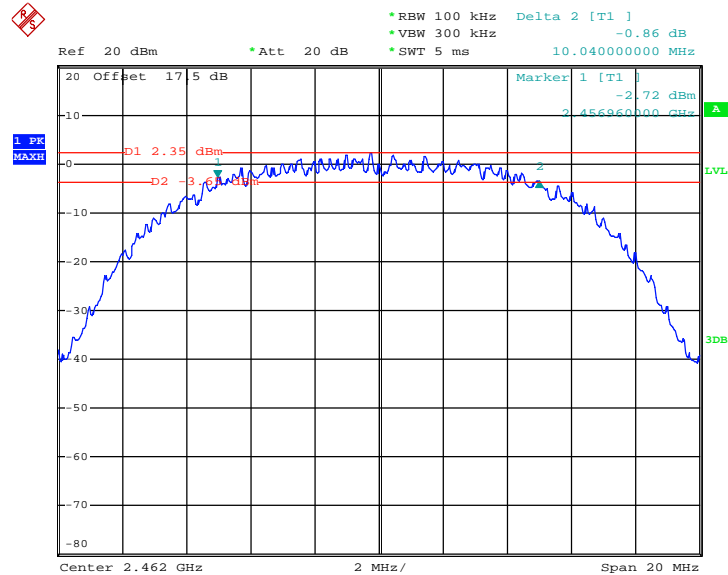

Date: 14.DEC.2012 17:10:17



Test Mode :	802.11g	Temperature :	20~21°C
Test Engineer :	Zhi Lu	Relative Humidity :	40~41%

Channel	Frequency (MHz)	802.11g 6dB Bandwidth (MHz)	6dB Bandwidth Min. Limit (MHz)	Pass/Fail
01	2412	16.44	0.5	Pass
06	2437	16.48	0.5	Pass
11	2462	16.48	0.5	Pass

6 dB Bandwidth Plot on 802.11g Channel 01

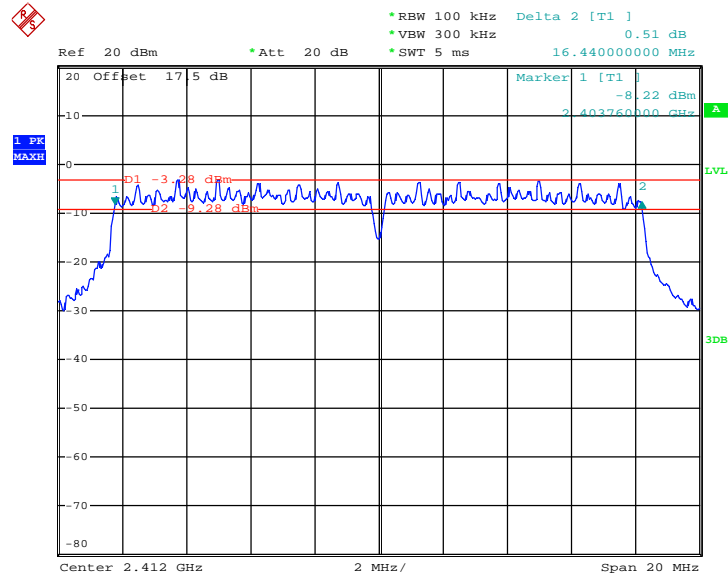

Date: 31.DEC.2012 16:22:08



6 dB Bandwidth Plot on 802.11g Channel 06

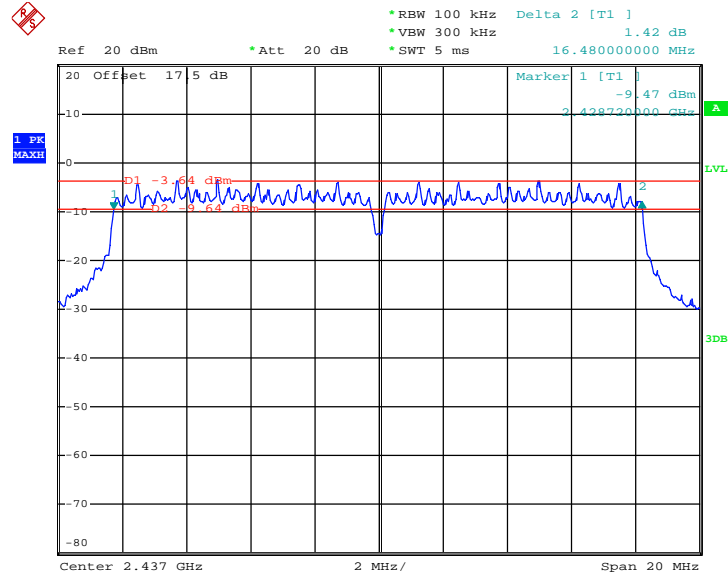

Date: 31.DEC.2012 16:23:28

6 dB Bandwidth Plot on 802.11g Channel 11

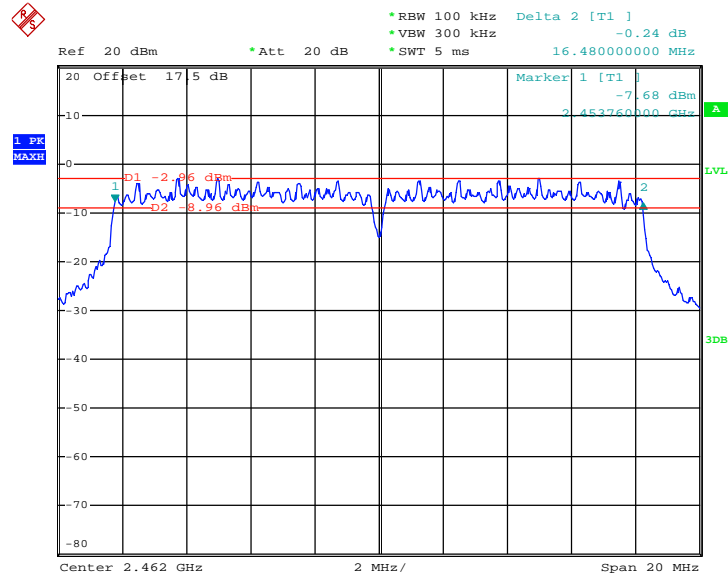

Date: 31.DEC.2012 16:25:28



Test Mode :	802.11n HT20	Temperature :	20~21°C
Test Engineer :	Zhi Lu	Relative Humidity :	40~41%

Channel	Frequency (MHz)	2.4GHz 802.11n HT20 6dB Bandwidth (MHz)	6dB Bandwidth Min. Limit (MHz)	Pass/Fail
01	2412	17.44	0.5	Pass
06	2437	17.12	0.5	Pass
11	2462	17.44	0.5	Pass

6 dB Bandwidth Plot on 802.11n HT20 Channel 01

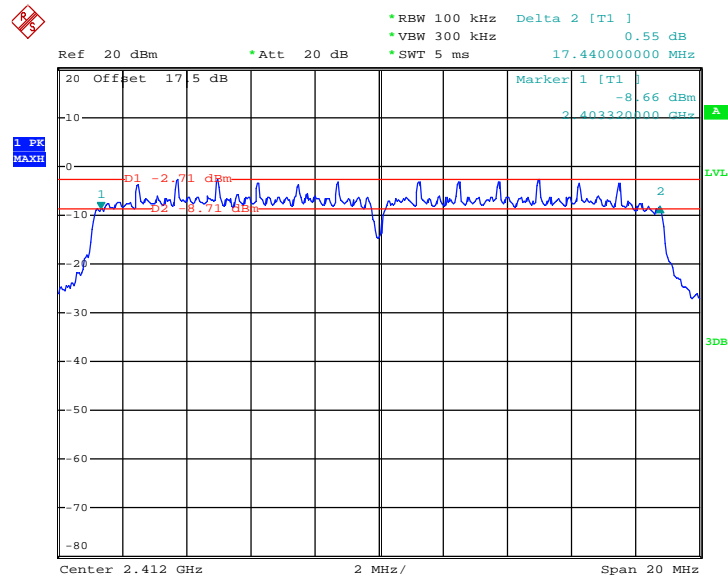

Date: 31.DEC.2012 16:20:32



6 dB Bandwidth Plot on 802.11n HT20 Channel 06

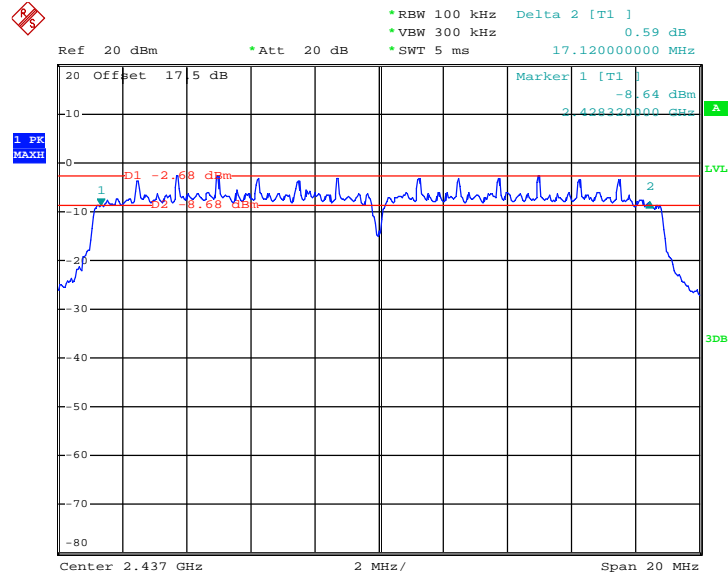

Date: 31.DEC.2012 16:18:28

6 dB Bandwidth Plot on 802.11n HT20 Channel 11

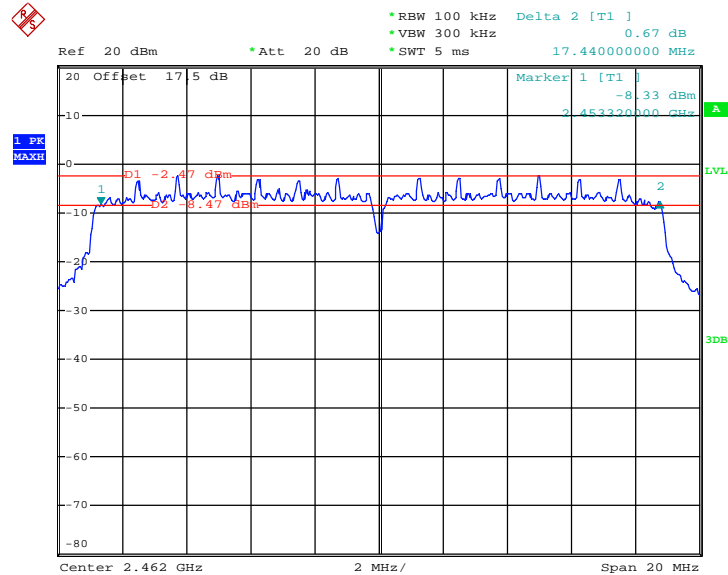

Date: 31.DEC.2012 16:16:22



3.1.6 Test Result of 99% Occupied Bandwidth

Test Mode :	802.11b	Temperature :	20~21°C
Test Engineer :	Zhi Lu	Relative Humidity :	40~41%

Channel	Frequency (MHz)	802.11b 99% Occupied Bandwidth (MHz)	Pass/Fail
01	2412	14.00	Pass
06	2437	14.00	Pass
11	2462	14.10	Pass

99% Occupied Bandwidth Plot on 802.11b Channel 01

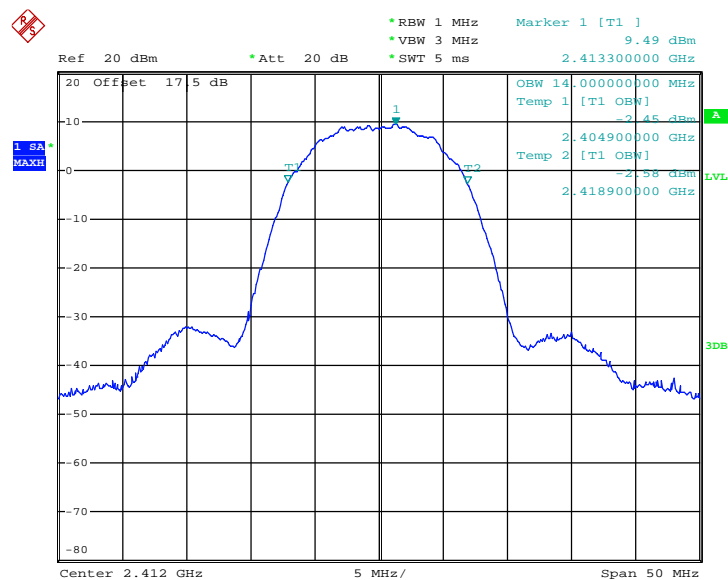

Date: 8.JAN.2013 17:48:50



99% Occupied Bandwidth Plot on 802.11b Channel 06

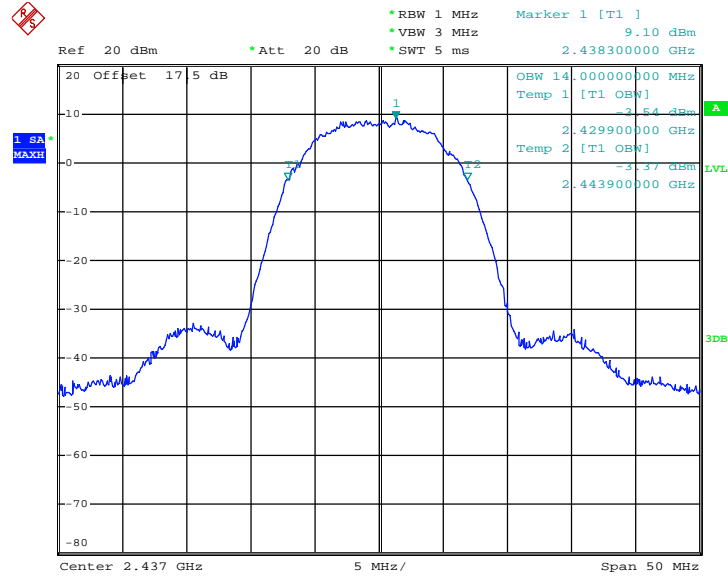

Date: 8.JAN.2013 17:49:26

99% Occupied Bandwidth Plot on 802.11b Channel 11

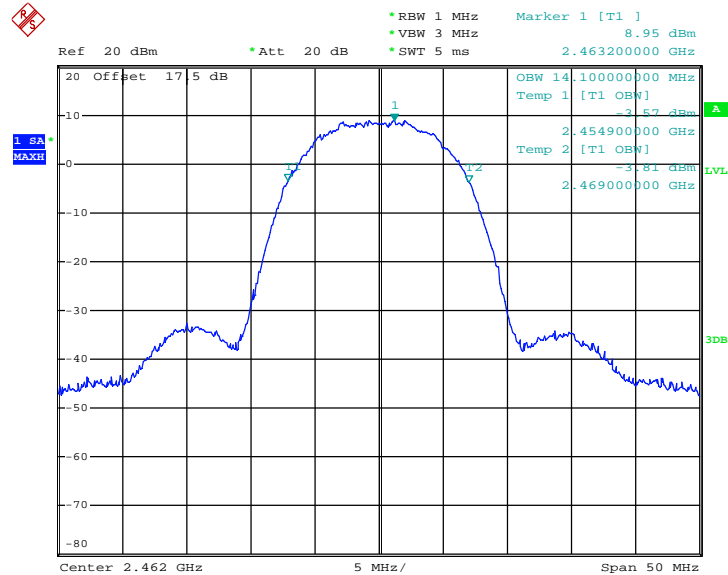

Date: 8.JAN.2013 17:50:08



Test Mode :	802.11g	Temperature :	20~21°C
Test Engineer :	Zhi Lu	Relative Humidity :	40~41%

Channel	Frequency (MHz)	802.11g 99% Occupied Bandwidth (MHz)	Pass/Fail
01	2412	18.00	Pass
06	2437	18.00	Pass
11	2462	18.00	Pass

99% Occupied Bandwidth Plot on 802.11g Channel 01

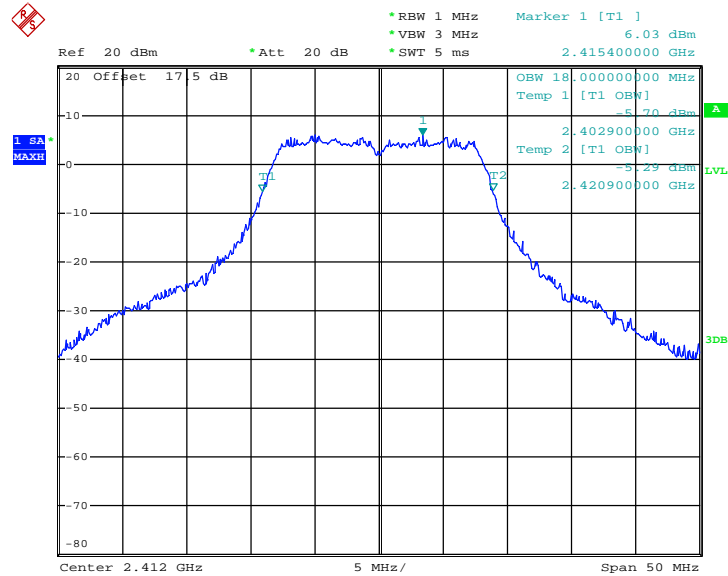

Date: 31.DEC.2012 17:27:48



99% Occupied Bandwidth Plot on 802.11g Channel 06

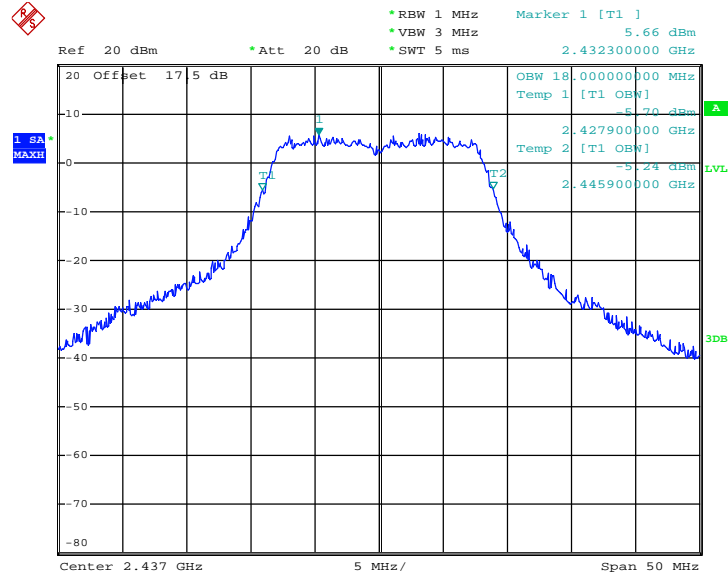

Date: 31.DEC.2012 17:28:37

99% Occupied Bandwidth Plot on 802.11g Channel 11

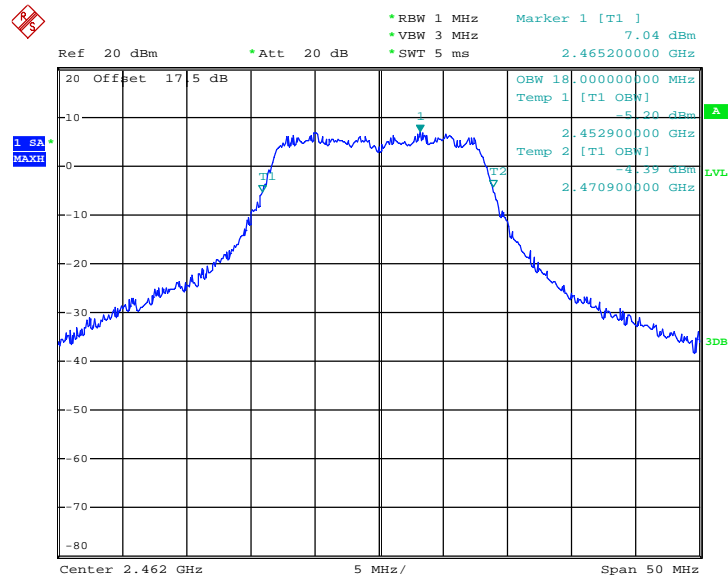

Date: 31.DEC.2012 17:29:45



Test Mode :	802.11n HT20	Temperature :	20~21°C
Test Engineer :	Zhi Lu	Relative Humidity :	40~41%

Channel	Frequency (MHz)	2.4GHz 802.11n HT20 99% Occupied Bandwidth (MHz)	Pass/Fail
01	2412	19.40	Pass
06	2437	19.40	Pass
11	2462	19.30	Pass

99% Occupied Bandwidth Plot 802.11n HT20 Channel 01

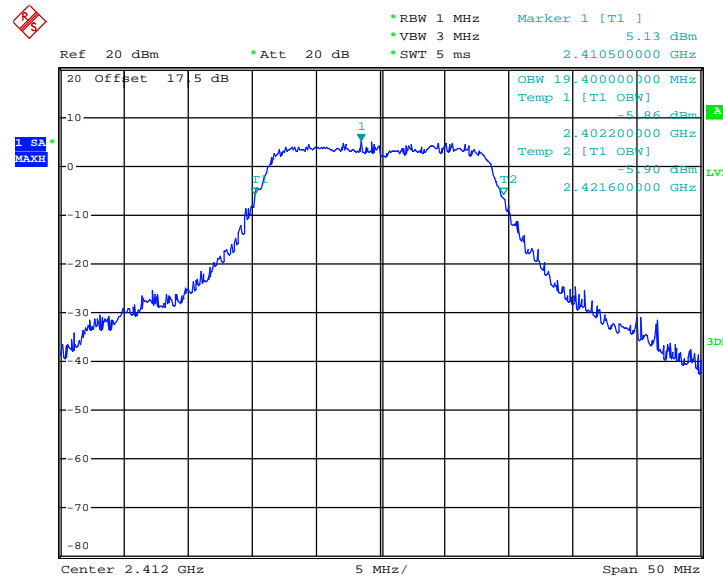

Date: 31.DEC.2012 17:26:29



99% Occupied Bandwidth Plot 802.11n HT20 Channel 06

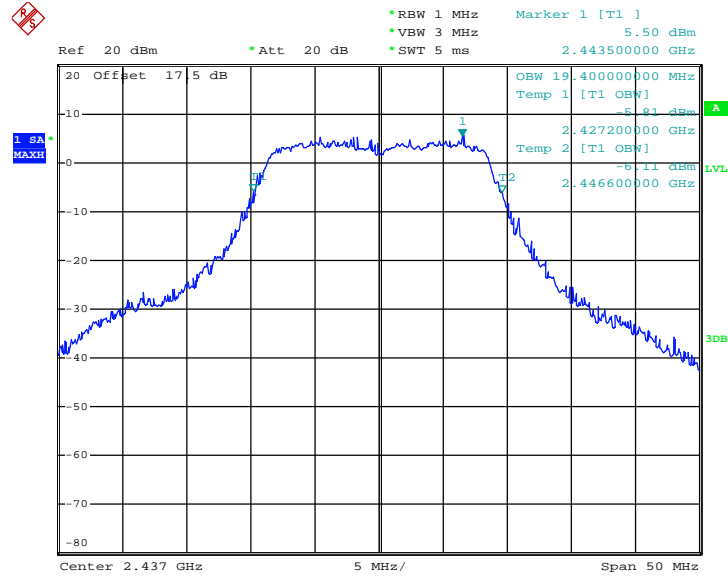

Date: 31.DEC.2012 17:25:39

99% Occupied Bandwidth Plot 802.11n HT20 Channel 11

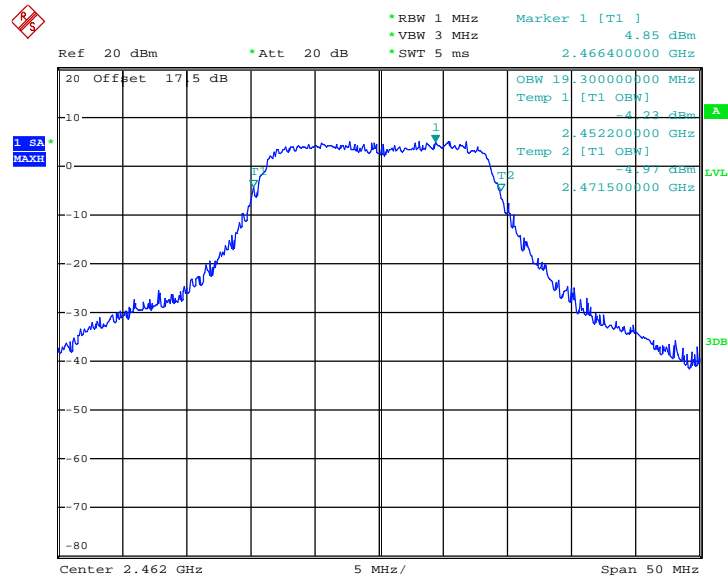

Date: 31.DEC.2012 17:24:51

3.2 Output Power Measurement

3.2.1 Limit of Output Power

For systems using digital modulation in the 2400-2483.5MHz, the limit for peak output power is 30dBm. If transmitting antenna of directional gain greater than 6dBi are used the peak output power from the intentional radiator shall be reduced below the above stated value by the amount in dB that the directional gain of the antenna exceeds 6 dBi. In case of point-to-point operation, the limit has to be reduced by 1dB for every 3dB that the directional gain of the antenna exceeds 6dBi.

3.2.2 Measuring Instruments

See list of measuring instruments of this test report.

3.2.3 Test Procedures

1. The testing follows the Measurement Procedure of FCC KDB No. 558074 DTS D01 Meas. Guidance v02.
2. The RF output of EUT was connected to the spectrum analyzer by RF cable and attenuator. The path loss was compensated to the results for each measurement.
3. Set to the maximum power setting and enable the EUT transmit continuously.
4. Measure the conducted output power and record the results in the test report.

3.2.4 Test Setup

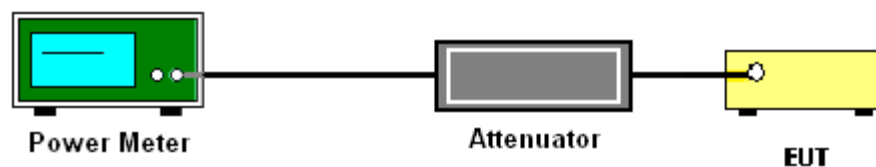



3.2.5 Test Result of Peak Output Power

Test Mode :	802.11b	Temperature :	20~21°C
Test Engineer :	Zhi Lu	Relative Humidity :	40~41%

Channel	Frequency (MHz)	802.11b Peak Output Power (dBm)	Max. Limits (dBm)	Pass/Fail
01	2412	19.72	30	Pass
06	2437	20.15	30	Pass
11	2462	20.61	30	Pass

Test Mode :	802.11g	Temperature :	20~21°C
Test Engineer :	Zhi Lu	Relative Humidity :	40~41%

Channel	Frequency (MHz)	802.11g Peak Output Power (dBm)	Max. Limits (dBm)	Pass/Fail
01	2412	17.73	30	Pass
06	2437	18.15	30	Pass
11	2462	18.62	30	Pass

Test Mode :	802.11n HT20	Temperature :	20~21°C
Test Engineer :	Zhi Lu	Relative Humidity :	40~41%

Channel	Frequency (MHz)	2.4GHz 802.11n HT20 Peak Output Power (dBm)	Max. Limits (dBm)	Pass/Fail
01	2412	17.17	30	Pass
06	2437	17.61	30	Pass
11	2462	18.51	30	Pass



3.2.6 Test Result of Average output Power (Reporting Only)

Test Mode :	802.11b	Temperature :	20~21°C
Test Engineer :	Zhi Lu	Relative Humidity :	40~41%
Duty Cycle:	97.90%	Duty Factor:	0.09dB

Channel	Frequency (MHz)	802.11b Average Output Power (dBm)
01	2412	11.59
06	2437	11.94
11	2462	11.39

Test Mode :	802.11g	Temperature :	20~21°C
Test Engineer :	Zhi Lu	Relative Humidity :	40~41%
Duty Cycle:	95.68%	Duty Factor:	0.19dB

Channel	Frequency (MHz)	802.11g Average Output Power (dBm)
01	2412	8.39
06	2437	8.79
11	2462	8.90

Test Mode :	802.11n HT20	Temperature :	20~21°C
Test Engineer :	Zhi Lu	Relative Humidity :	40~41%
Duty Cycle:	94.46%	Duty Factor:	0.25dB

Channel	Frequency (MHz)	802.11n HT20 Average Output Power (dBm)
01	2412	8.32
06	2437	8.44
11	2462	8.84

3.3 Power Spectral Density Measurement

3.3.1 Limit of Power Spectral Density

The peak power spectral density shall not be greater than 8dBm in any 3KHz band at any time interval of continuous transmission.

3.3.2 Measuring Instruments

See list of measuring instruments of this test report.

3.3.3 Test Procedures

1. The testing follows Measurement Procedure 9.1 Option 1 of FCC KDB Publication No. 558074 D01 DTS Meas. Guidance v02
2. The RF output of EUT was connected to the spectrum analyzer by RF cable and attenuator. The path loss was compensated to the results for each measurement.
3. Set to the maximum power setting and enable the EUT transmit continuously.
4. Make the measurement with the spectrum analyzer's resolution bandwidth (RBW) = 3 kHz. Video bandwidth VBW = 10 kHz In order to make an accurate measurement, set the span to 1.5 times DTS Channel Bandwidth. (6dB BW)
5. Detector = peak, Sweep time = auto couple, Trace mode = max hold, Allow trace to fully stabilize. Use the peak marker function to determine the maximum power level.
6. Measure and record the results in the test report.

3.3.4 Test Setup

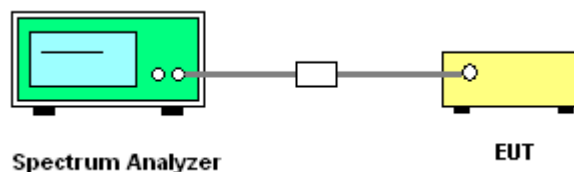

3.3.5 Test Result of Power Spectral Density

Test Mode :	802.11b	Temperature :	20~21°C
Test Engineer :	Zhi Lu	Relative Humidity :	40~41%

Channel	Frequency (MHz)	802.11b Power Density		Max. Limits (dBm/3KHz)	Pass/Fail
		PSD/100KHz (dBm)	PSD/3KHz (dBm)		
01	2412	-0.30	-11.85	8	Pass
06	2437	0.00	-11.99	8	Pass
11	2462	0.34	-11.69	8	Pass

Test Mode :	802.11g	Temperature :	20~21°C
Test Engineer :	Zhi Lu	Relative Humidity :	40~41%

Channel	Frequency (MHz)	802.11g Power Density		Max. Limits (dBm/3KHz)	Pass/Fail
		PSD/100KHz (dBm)	PSD/3KHz (dBm)		
01	2412	-3.39	-17.40	8	Pass
06	2437	-3.37	-16.83	8	Pass
11	2462	-2.70	-16.48	8	Pass

Test Mode :	802.11n HT20	Temperature :	20~21°C
Test Engineer :	Zhi Lu	Relative Humidity :	40~41%

Channel	Frequency (MHz)	802.11n HT20 Power Density		Max. Limits (dBm/3KHz)	Pass/Fail
		PSD/100KHz (dBm)	PSD/3KHz (dBm)		
01	2412	-2.62	-16.70	8	Pass
06	2437	-2.87	-16.52	8	Pass
11	2462	-2.51	-17.34	8	Pass

Note:

1. Measured power density (dBm) has offset with cable loss.
2. The Measured power density (dBm)/ 100KHz is reference level and used as 20dBc down for Conducted Band Edges and Conducted Spurious Emission limit line.



3.3.6 Test Result of Power Spectral Density Plots (100kHz)

PSD 100kHz Plot on 802.11b Channel 01

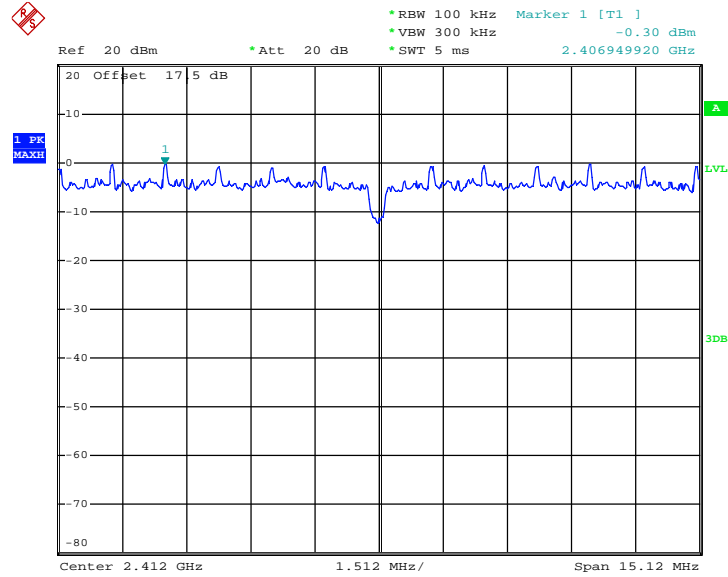

Date: 14.DEC.2012 17:29:20



PSD 100kHz Plot on 802.11b Channel 06

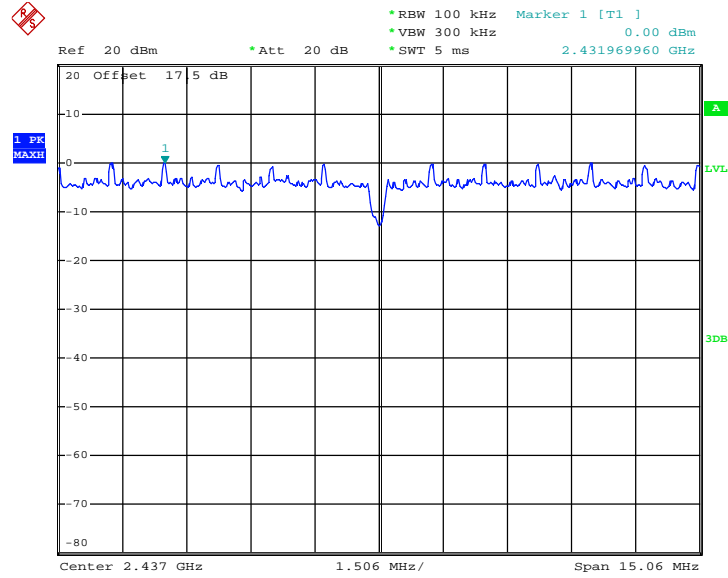

Date: 14.DEC.2012 17:34:48

PSD 100kHz Plot on 802.11b Channel 11

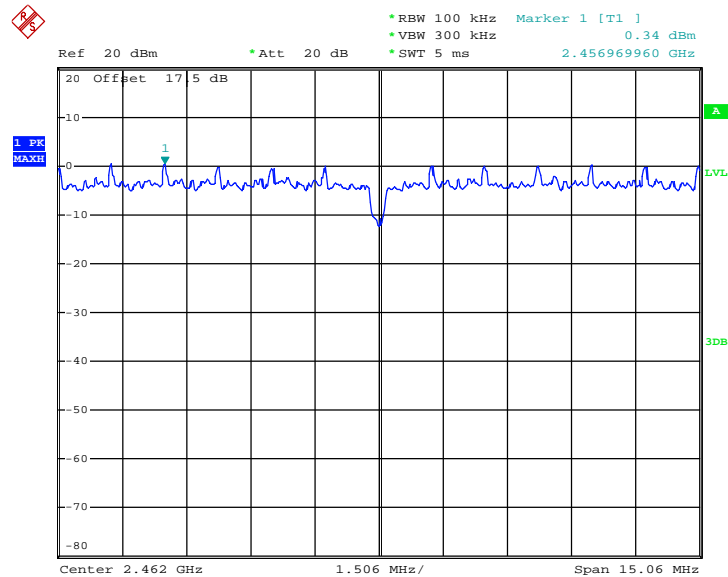

Date: 14.DEC.2012 17:33:18



PSD 100kHz Plot on 802.11g Channel 01

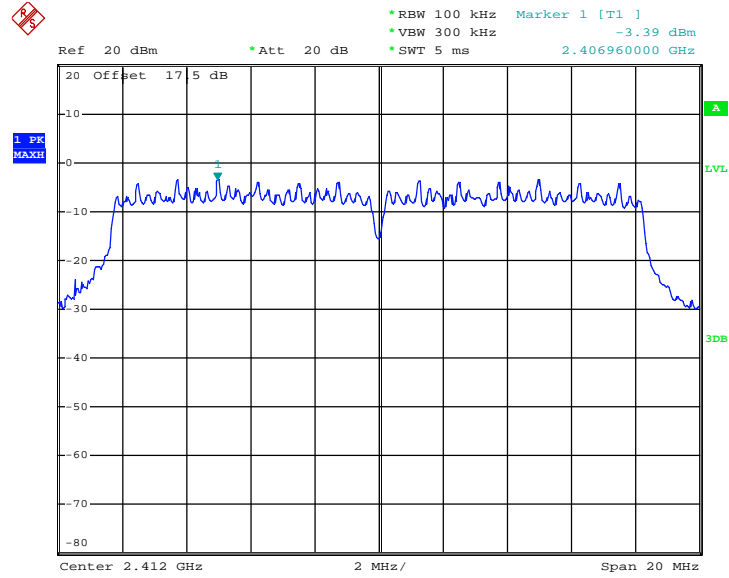

Date: 31.DEC.2012 15:57:19



PSD 100kHz Plot on 802.11g Channel 06

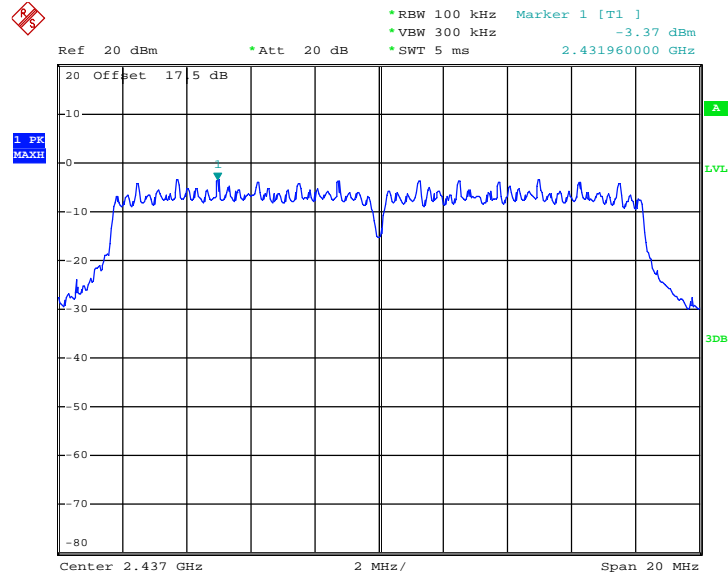

Date: 31.DEC.2012 15:56:39

PSD 100kHz Plot on 802.11g Channel 11

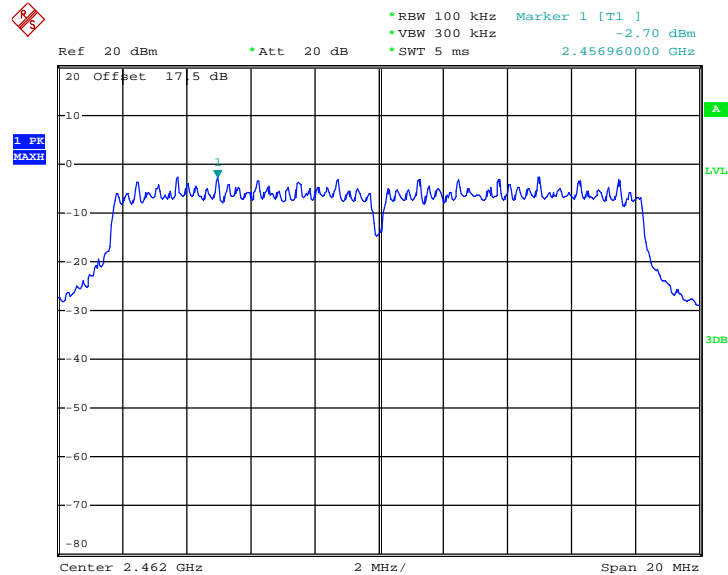

Date: 31.DEC.2012 15:55:42



PSD 100kHz Plot on 802.11n HT20 Channel 01

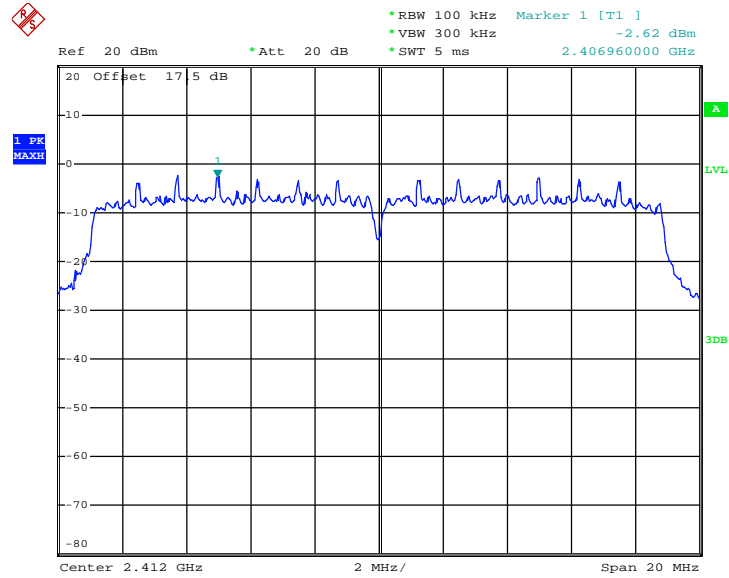

Date: 31.DEC.2012 15:58:23



PSD 100kHz Plot on 802.11n HT20 Channel 06

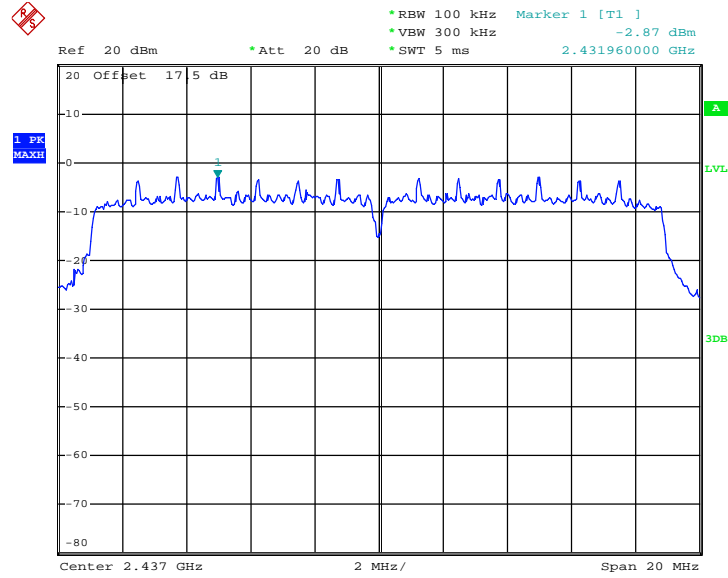

Date: 31.DEC.2012 16:01:38

PSD 100kHz Plot on 802.11n HT20 Channel 11

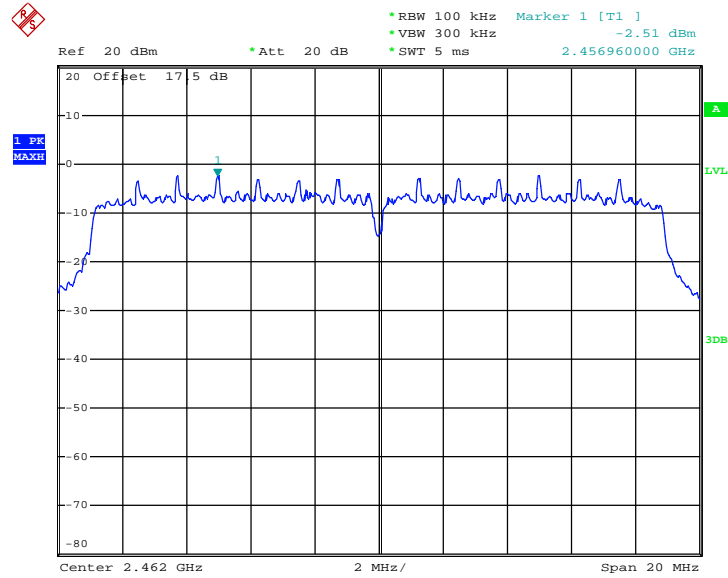

Date: 31.DEC.2012 16:12:37



3.3.7 Test Result of Power Spectral Density Plots (3kHz)

PSD 3kHz Plot on 802.11b Channel 01

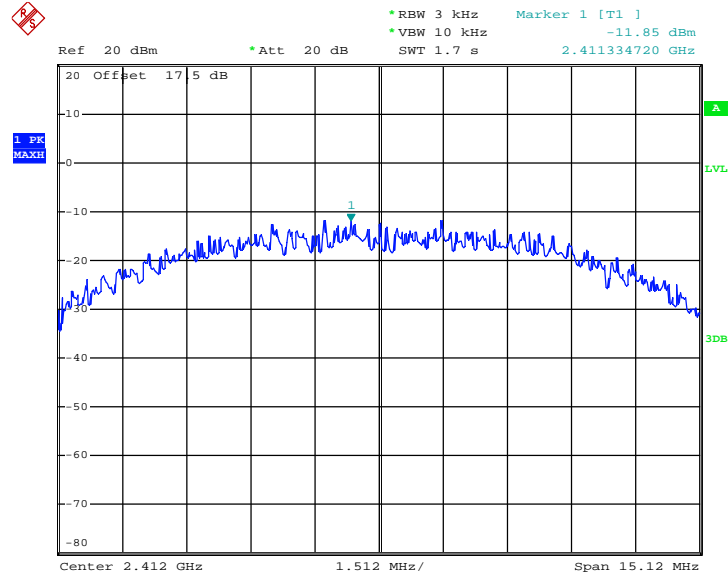

Date: 14.DEC.2012 17:50:50



PSD 3kHz Plot on 802.11b Channel 06

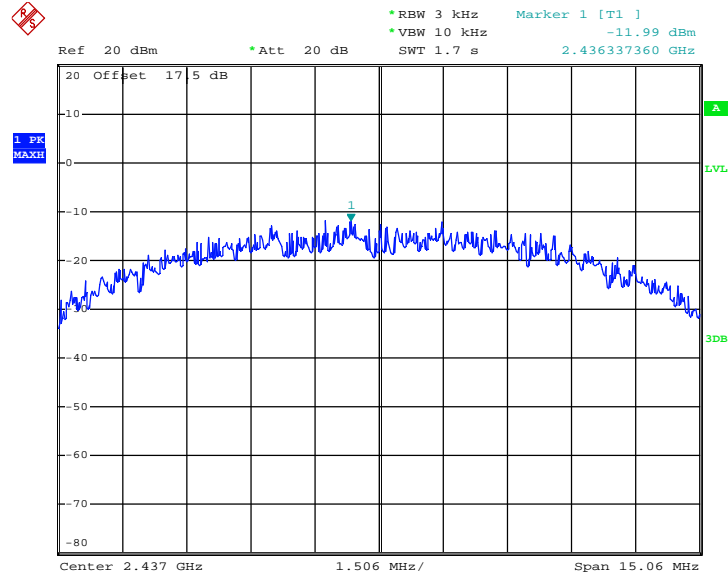

Date: 14.DEC.2012 17:52:03

PSD 3kHz Plot on 802.11b Channel 11

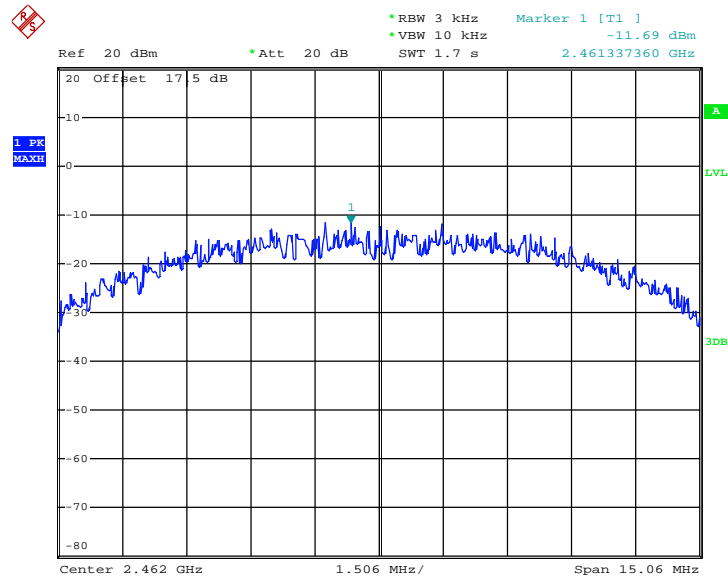

Date: 14.DEC.2012 19:01:21



PSD 3kHz Plot on 802.11g Channel 01

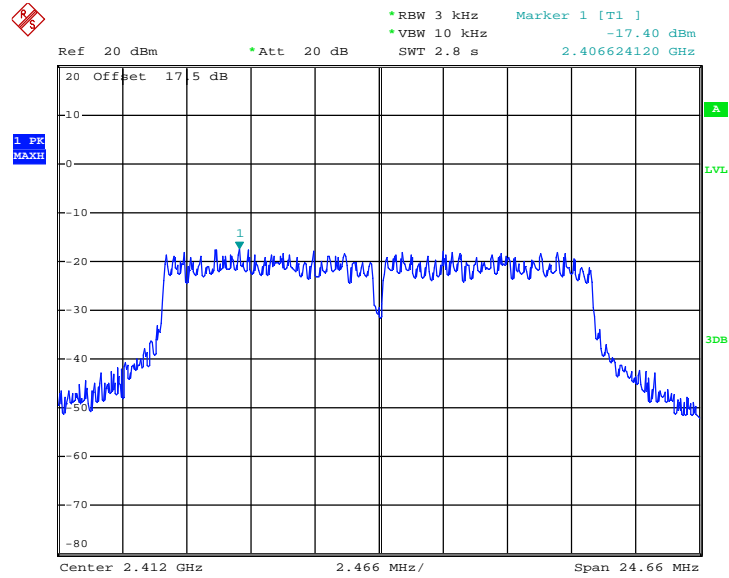

Date: 31.DEC.2012 16:45:59



PSD 3kHz Plot on 802.11g Channel 06

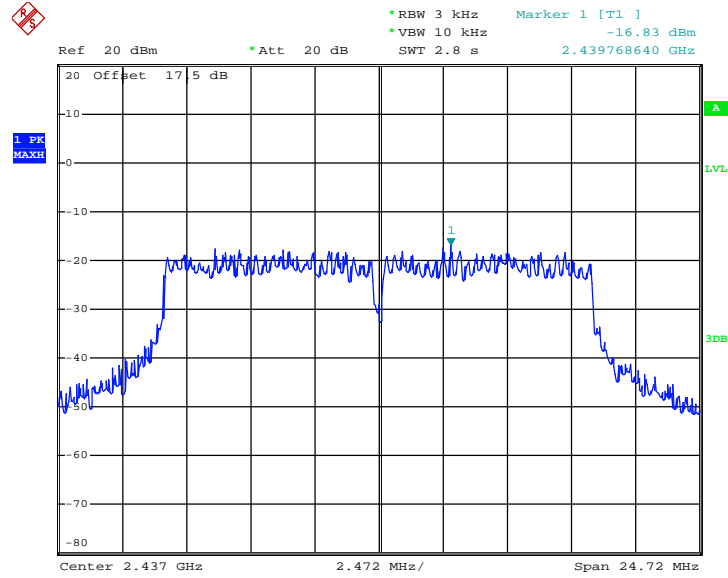

Date: 31.DEC.2012 16:50:22

PSD 3kHz Plot on 802.11g Channel 11

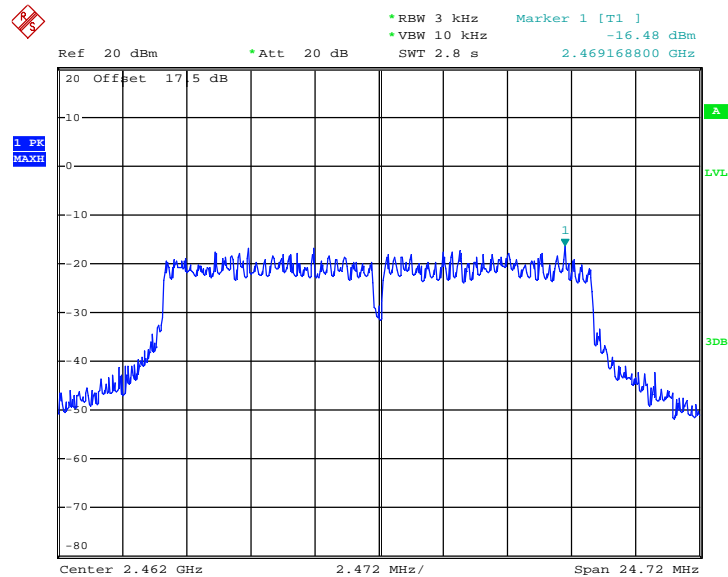

Date: 31.DEC.2012 16:48:33



PSD 3kHz Plot on 802.11n HT20 Channel 01

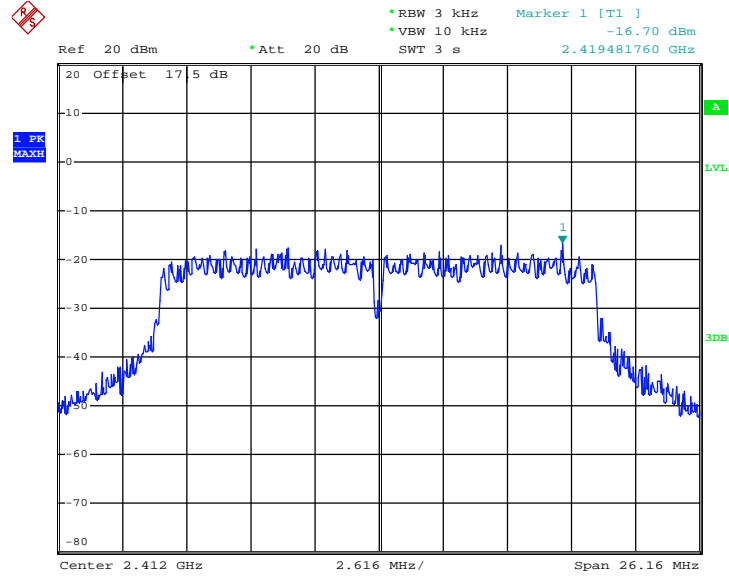

Date: 31.DEC.2012 16:52:28



PSD 3kHz Plot on 802.11n HT20 Channel 06

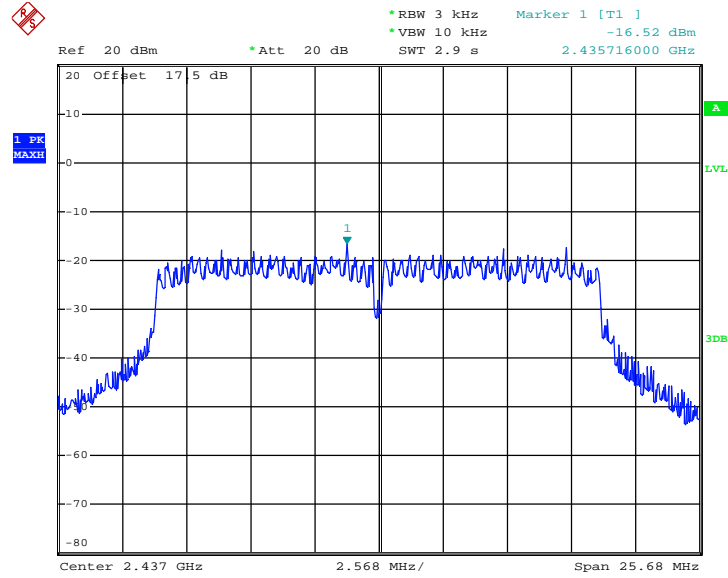

Date: 31.DEC.2012 16:53:43

PSD 3kHz Plot on 802.11n HT20 Channel 11

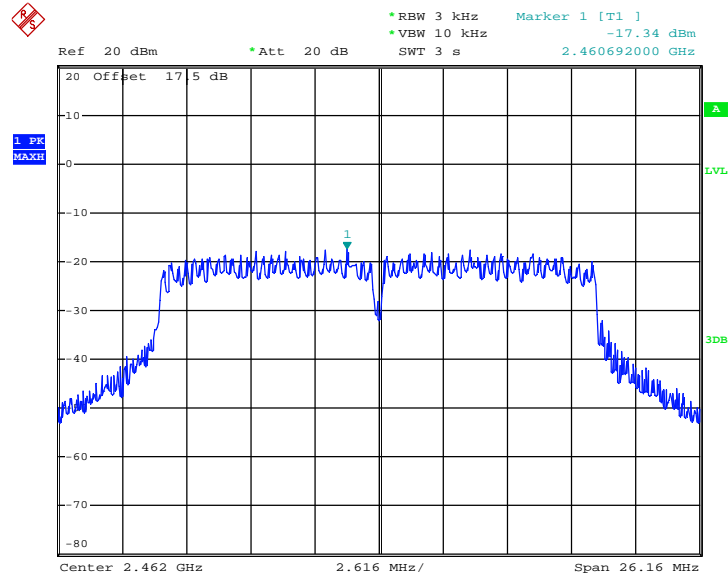

Date: 31.DEC.2012 16:55:14

3.4 Conducted Band Edges and Spurious Emission Measurement

3.4.1 Limit of Conducted Band Edges and Spurious Emission Measurement

In any 100 kHz bandwidth outside of the authorized frequency band, the emissions which fall in the non-restricted bands shall be attenuated at least 20 dB / 30dB relative to the maximum PSD level in 100 kHz by RF conducted measurement and radiated emissions which fall in the restricted bands, as defined in Section 15.205(a), must also comply with the radiated emission limits specified in Section 15.209(a).

3.4.2 Measuring Instruments

See list of measuring instruments of this test report.

3.4.3 Test Procedures

1. The testing follows the Measurement Procedure of FCC KDB No. 558074 DTS D01 Meas. Guidance v02.
2. The RF output of EUT was connected to the spectrum analyzer by RF cable and attenuator. The path loss was compensated to the results for each measurement.
3. Set to the maximum power setting and enable the EUT transmit continuously.
4. Set RBW = 100 KHz, VBW=300 KHz, Peak Detector. Unwanted Emissions measured in any 100 kHz bandwidth outside of the authorized frequency band shall be attenuated by at least 20 dB relative to the maximum in-band peak PSD level in 100 kHz, when maximum peak conducted output power procedure is used. The attenuation is set to 30dB, when maximum conducted output power procedure is used.
5. Measure and record the results in the test report.

3.4.4 Test Setup

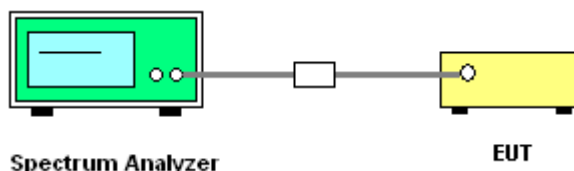



Test Mode :	802.11g	Temperature :	20~21°C
Test Band :	Low and High	Relative Humidity :	40~41%
Test Channel :	01 and 11	Test Engineer :	Zhi Lu

Low Band Edge Plot on 802.11g Channel 01

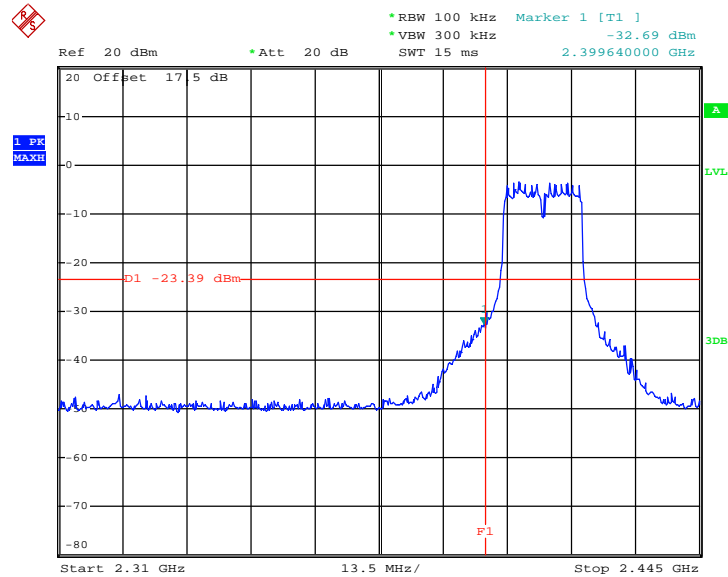

Date: 31.DEC.2012 17:19:55

High Band Edge Plot on 802.11g Channel 11

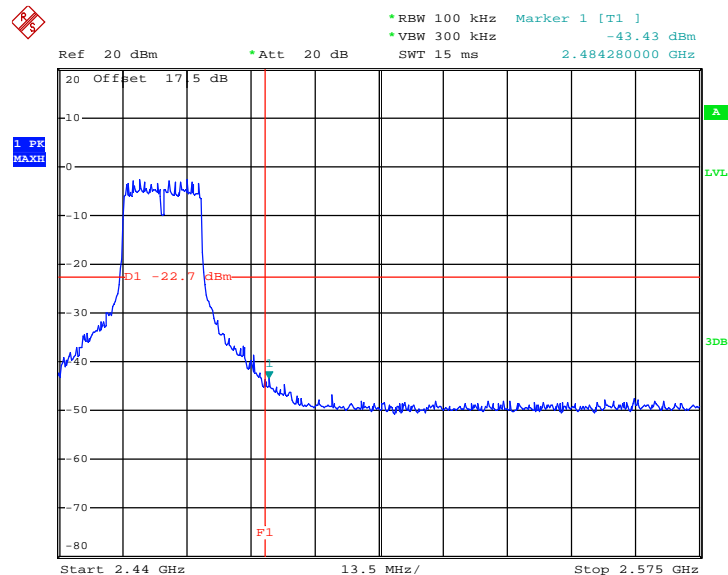

Date: 31.DEC.2012 17:18:22



Test Mode :	802.11n HT20	Temperature :	20~21°C
Test Band :	Low and High	Relative Humidity :	40~41%
Test Channel :	01 and 11	Test Engineer :	Zhi Lu

Low Band Edge Plot on 802.11n HT20 Channel 01

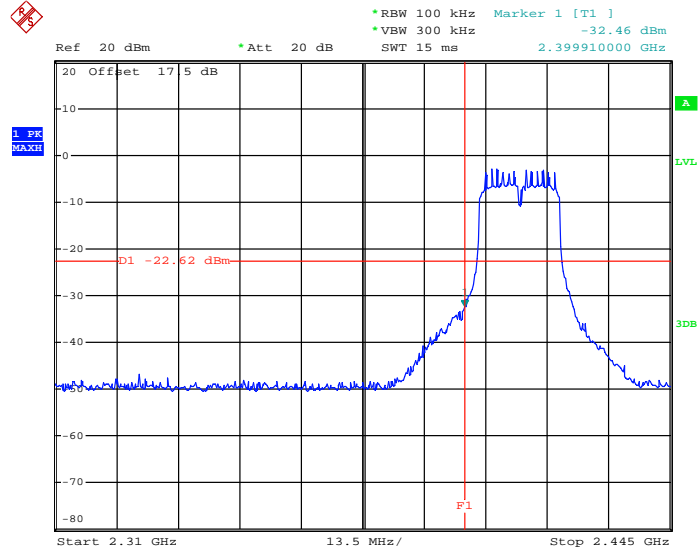

Date: 31.DEC.2012 17:21:22

High Band Edge Plot on 802.11n HT20 Channel 11

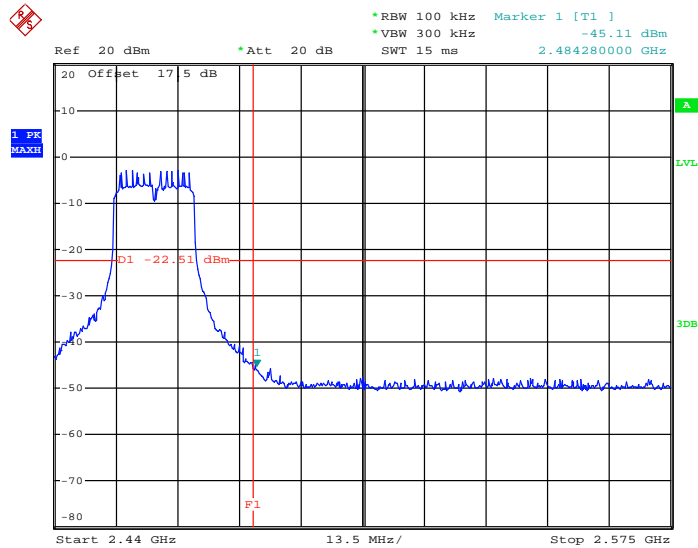

Date: 31.DEC.2012 17:22:48

3.4.6 Test Plots of Spurious Emission

Test Mode :	802.11b	Temperature :	20~21°C
Test Band :	30MHz-3GHz and 2G-25GHz	Relative Humidity :	40~41%
Test Channel :	01, 06, 11	Test Engineer :	Zhi Lu

802.11b 30 MHz~3 GHz

Conducted Spurious Emission Plot on Channel 01

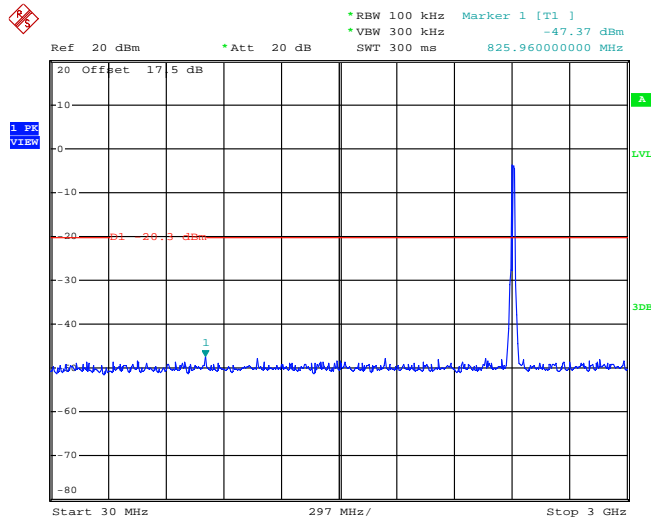

Date: 14.DEC.2012 19:25:06

802.11b 2 GHz~25 GHz

Conducted Spurious Emission Plot on Channel 01

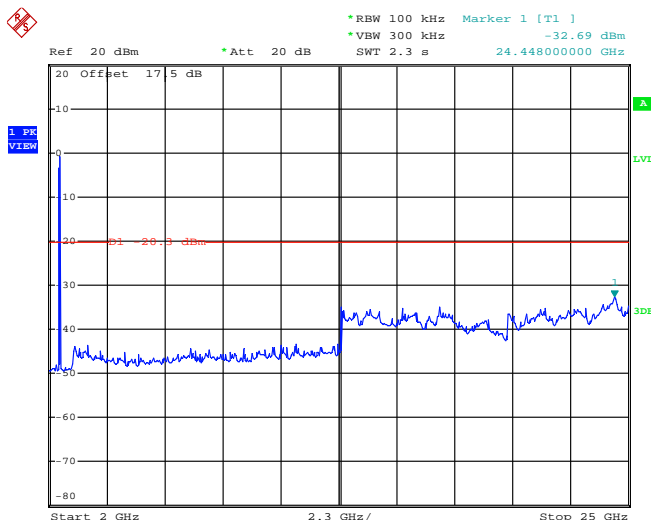

Date: 14.DEC.2012 19:24:30



802.11b 30 MHz~3 GHz

Conducted Spurious Emission Plot on Channel 06

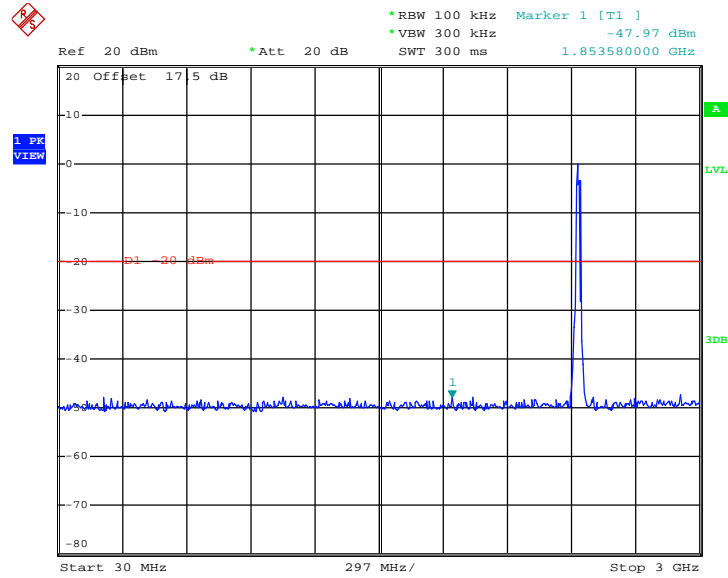

Date: 14.DEC.2012 19:22:20

802.11b 2 GHz~25 GHz

Conducted Spurious Emission Plot on Channel 06

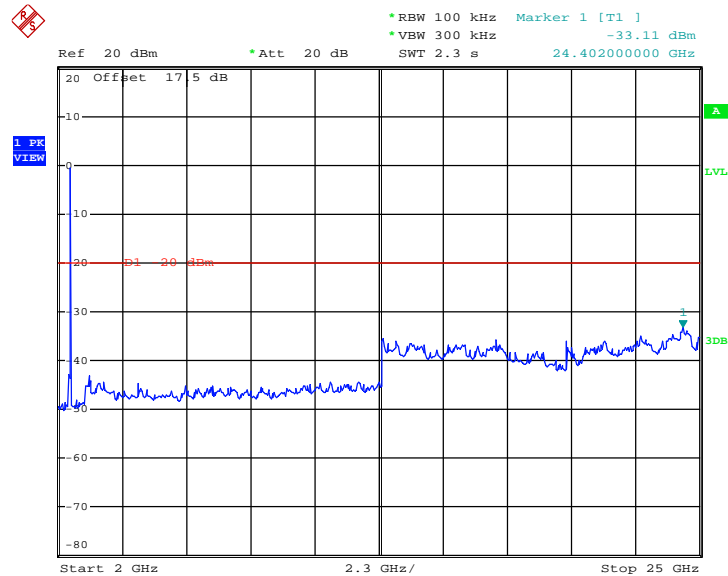

Date: 14.DEC.2012 19:23:05



802.11b 30 MHz~3 GHz

Conducted Spurious Emission Plot on Channel 11

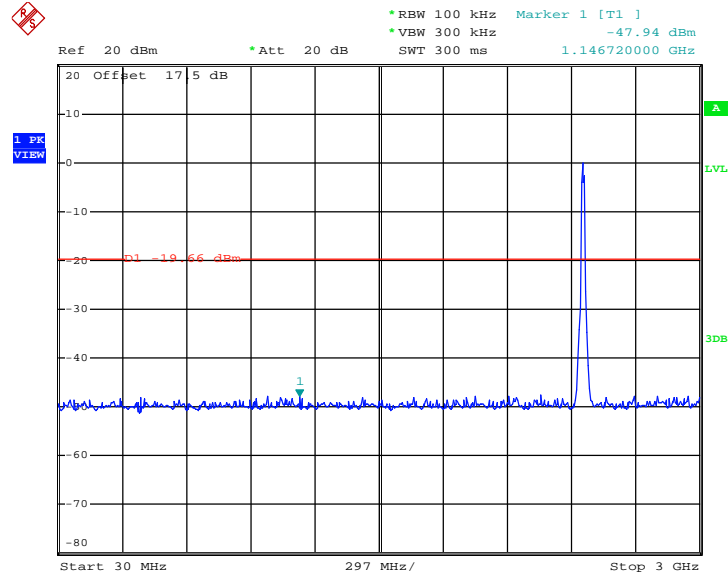

Date: 14.DEC.2012 19:26:40

802.11b 2 GHz~25 GHz

Conducted Spurious Emission Plot on Channel 11

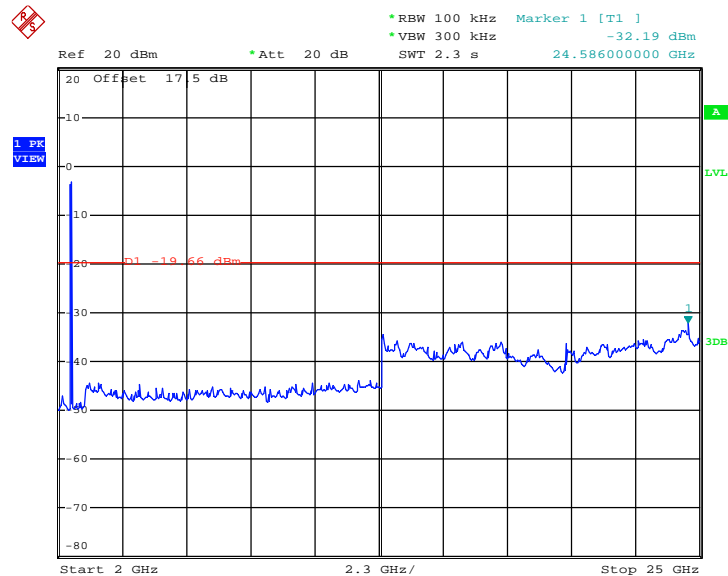

Date: 14.DEC.2012 19:27:31



Test Mode :	802.11g	Temperature :	20~21°C
Test Band :	30MHz-3GHz and 2G-25GHz	Relative Humidity :	40~41%
Test Channel :	01, 06, 11	Test Engineer :	Zhi Lu

802.11g 30 MHz~3 GHz

Conducted Spurious Emission Plot on Channel 01

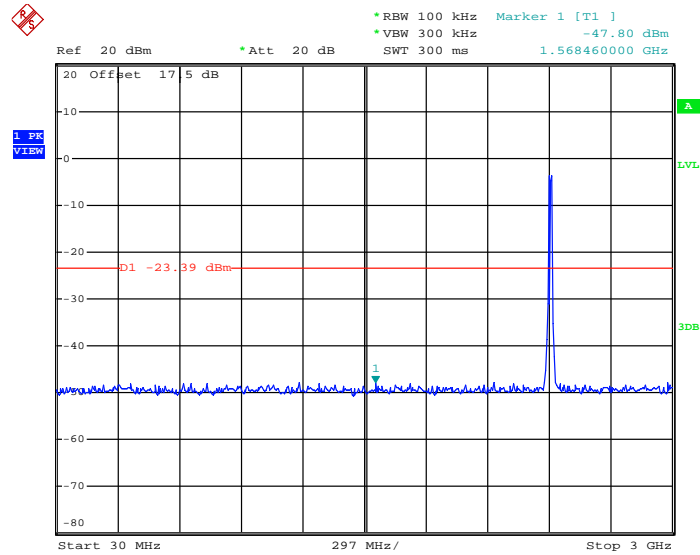

Date: 31.DEC.2012 17:11:34

802.11g 2 GHz~25 GHz

Conducted Spurious Emission Plot on Channel 01

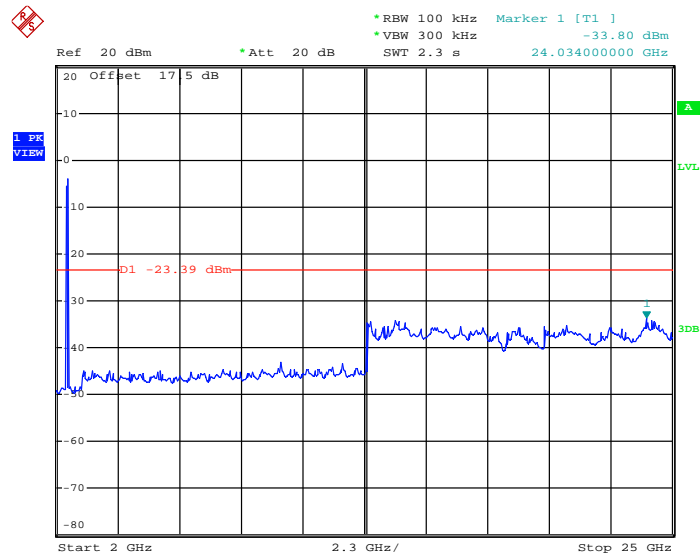

Date: 31.DEC.2012 17:12:46



802.11g 30 MHz~3 GHz

Conducted Spurious Emission Plot on Channel 06

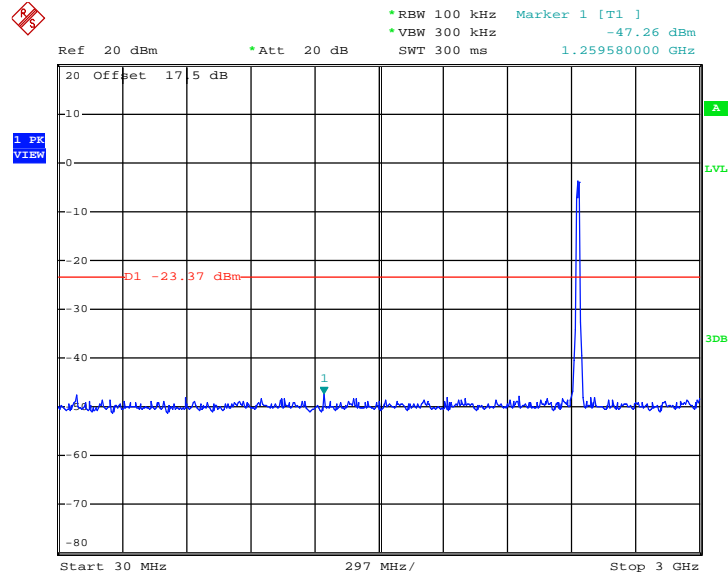

Date: 31.DEC.2012 17:14:02

802.11g 2 GHz~25 GHz

Conducted Spurious Emission Plot on Channel 06

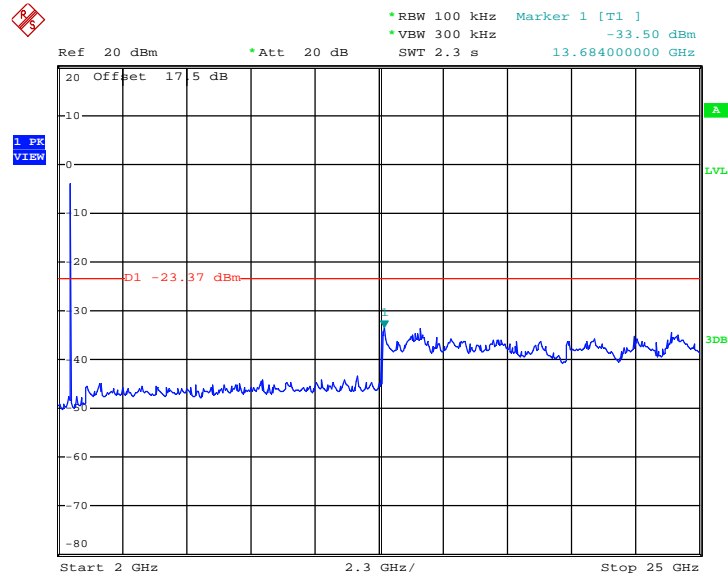

Date: 31.DEC.2012 17:14:51



802.11g 30 MHz~3 GHz

Conducted Spurious Emission Plot on Channel 11

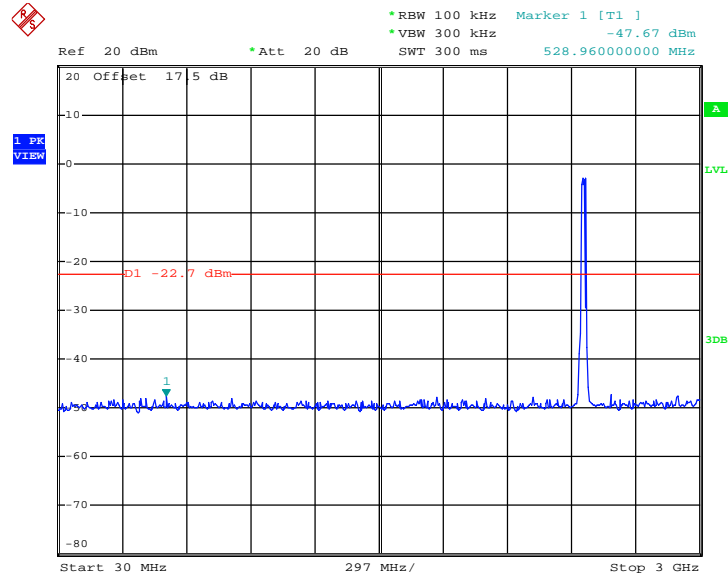

Date: 31.DEC.2012 17:16:24

802.11g 2 GHz~25 GHz

Conducted Spurious Emission Plot on Channel 11

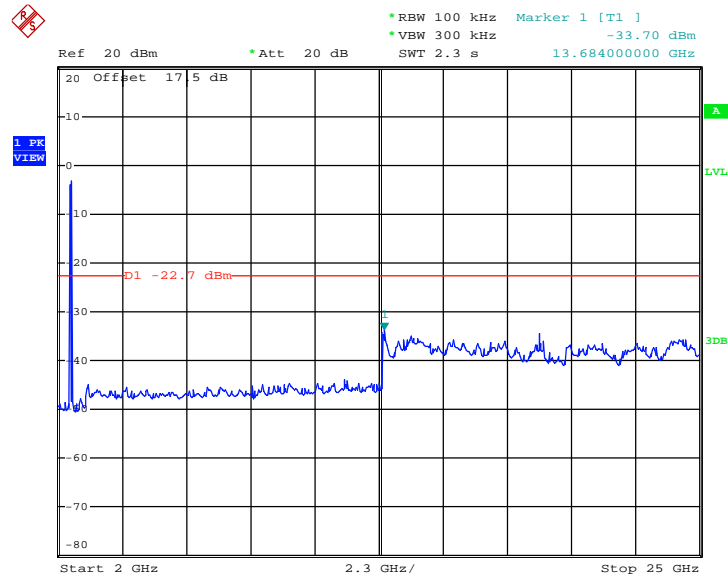

Date: 31.DEC.2012 17:16:54



Test Mode :	802.11n HT20	Temperature :	20~21°C
Test Band :	30MHz-3GHz and 2G-25GHz	Relative Humidity :	40~41%
Test Channel :	01, 06, 11	Test Engineer :	Zhi Lu

802.11n HT20 30 MHz~3 GHz

Conducted Spurious Emission Plot on Channel 01

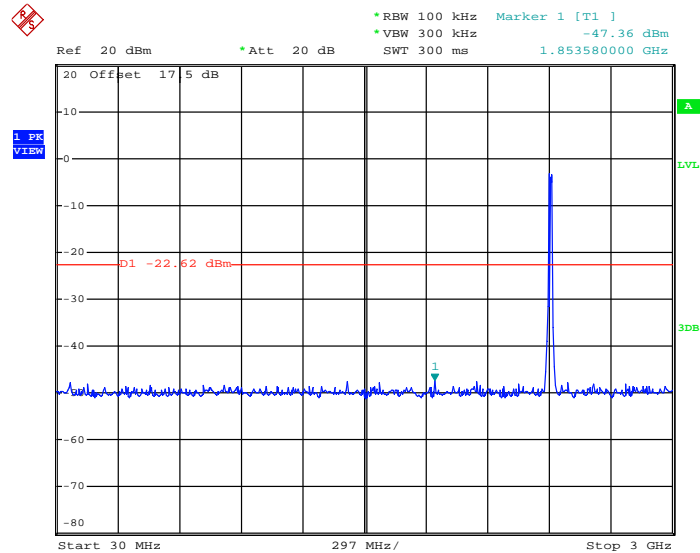

Date: 31.DEC.2012 17:04:46

802.11n HT20 2 GHz~25 GHz

Conducted Spurious Emission Plot on Channel 01

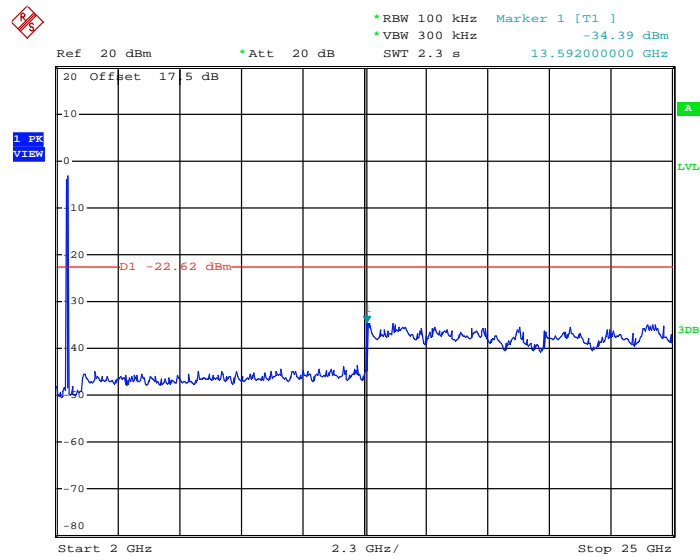

Date: 31.DEC.2012 17:05:48



802.11n HT20 30 MHz~3 GHz

Conducted Spurious Emission Plot on Channel 06

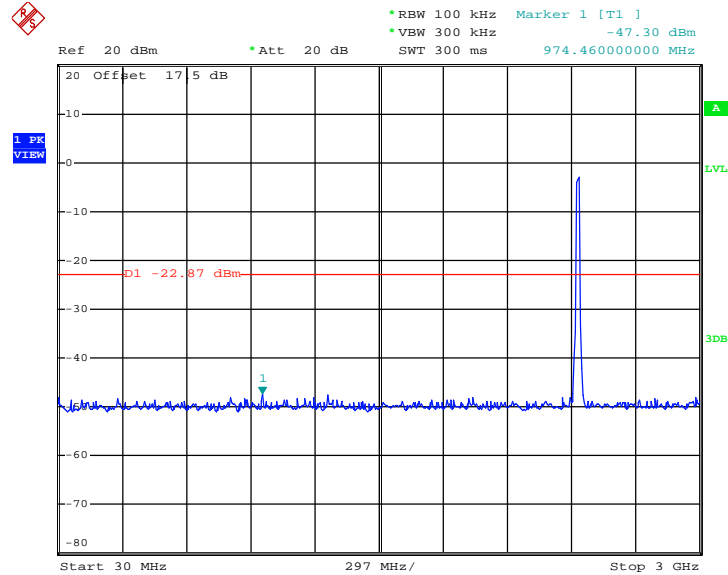

Date: 31.DEC.2012 17:02:03

802.11n HT20 2 GHz~25 GHz

Conducted Spurious Emission Plot on Channel 06

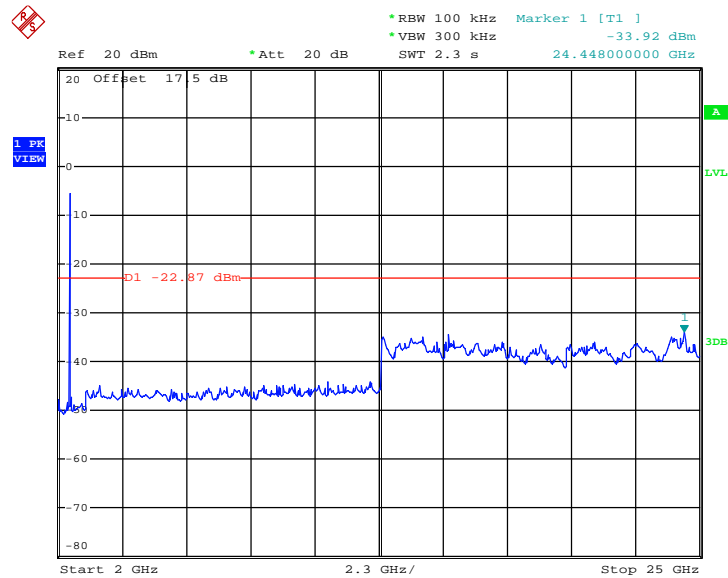

Date: 31.DEC.2012 17:01:25



802.11n HT20 30 MHz~3 GHz

Conducted Spurious Emission Plot on Channel 11

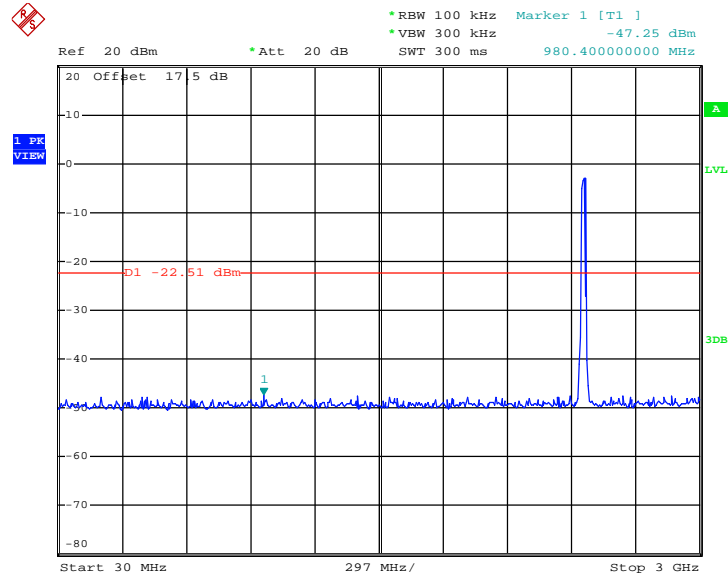

Date: 31.DEC.2012 16:59:08

802.11n HT20 2 GHz~25 GHz

Conducted Spurious Emission Plot on Channel 11

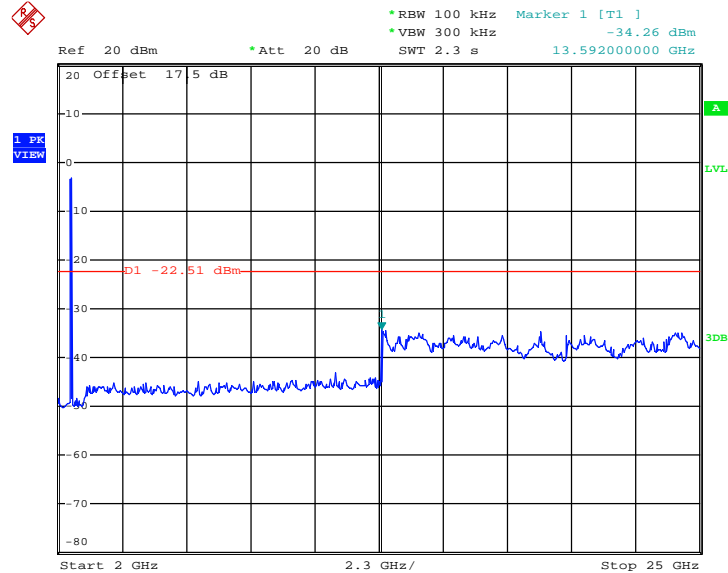

Date: 31.DEC.2012 16:59:51



3.5 Radiated Emission Measurement

3.5.1 Limit of Radiated Emission

In any 100 KHz bandwidth outside the intentional radiator frequency band, all harmonics/spurious must be at least 20 dB below the highest emission level within the authorized band. If the output power of this device was measured by spectrum analyzer, the attenuation under this paragraph shall be 30 dB instead of 20 dB. In addition, radiated emissions which fall in the restricted bands must also comply with the FCC section 15.209 limits as below.

Frequency (MHz)	Field Strength (microvolts/meter)	Measurement Distance (meters)
0.009 – 0.490	2400/F(KHz)	300
0.490 – 1.705	24000/F(KHz)	30
1.705 – 30.0	30	30
30 – 88	100	3
88 – 216	150	3
216 - 960	200	3
Above 960	500	3

3.5.2 Measuring Instruments

See list of measuring instruments of this test report.

3.5.3 Test Procedures

1. The testing follows the guidelines in ANSI C63. 10-2009
2. The EUT was arranged to its worst case and then tune the antenna tower (from 1 m to 4 m) and turntable (from 0 degree to 360 degrees) to find the maximum reading. A pre-amp and a high pass filter are used for the test in order to get better signal level.
3. The EUT was placed on a turntable with 0.8 meter above ground.
4. The EUT was set 3 meters from the interference receiving antenna, which was mounted on the top of a variable height antenna tower.
5. Corrected Reading: Antenna Factor + Cable Loss + Read Level - Preamp Factor = Level
6. For measurement below 1GHz, If the emission level of the EUT measured by the peak detector is 3 dB lower than the applicable limit, the peak emission level will be reported. Otherwise, the emission measurement will be repeated using the quasi-peak detector and reported.
7. Use the following spectrum analyzer settings:
 - (1) Span shall wide enough to fully capture the emission being measured;
 - (2) Set RBW=100 KHz for $f < 1$ GHz; $VBW \geq RBW$; Sweep = auto; Detector function = peak; Trace = max hold;
 - (3) Set RBW = 1 MHz, $VBW = 3$ MHz for $f \geq 1$ GHz for peak measurement.
 For average measurement:
 - $VBW = 10$ Hz, when duty cycle is no less than 98 percent.
 - $VBW \geq 1/T$, when duty cycle is less than 98 percent where T is the minimum transmission duration over which the transmitter is on and is transmitting at its maximum power control level for the tested mode of operation.

Band	Duty Cycle(%)	T(ms)	1/T(KHz)	VBW Setting
802.11b	97.904	1.308	0.76452599	1KHz
802.11g	93.380	0.536	1.86567164	3KHz
802.11n HT20	94.460	0.665	1.5037594	3KHz

Note: For average measurement with duty cycle < 98%, use reduced VBW measurement method 4.2.3.2.3 in ANSI C63.10.

3.5.4 Test Setup

For radiated emissions below 30MHz

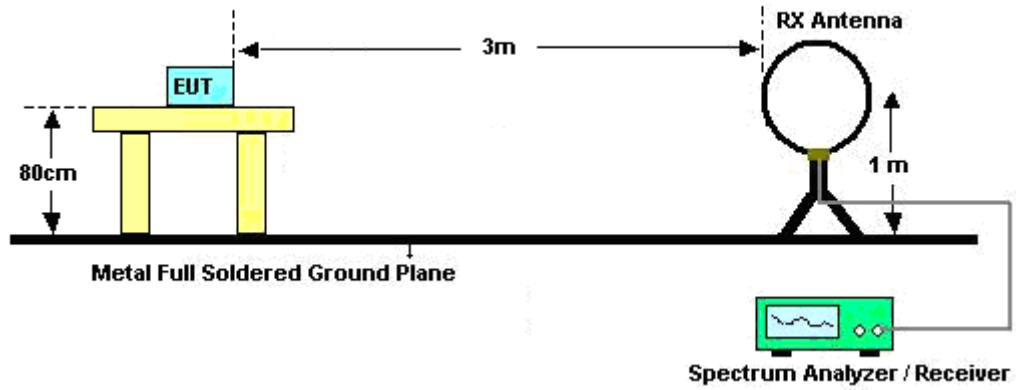

For radiated emissions from 30MHz to 1GHz

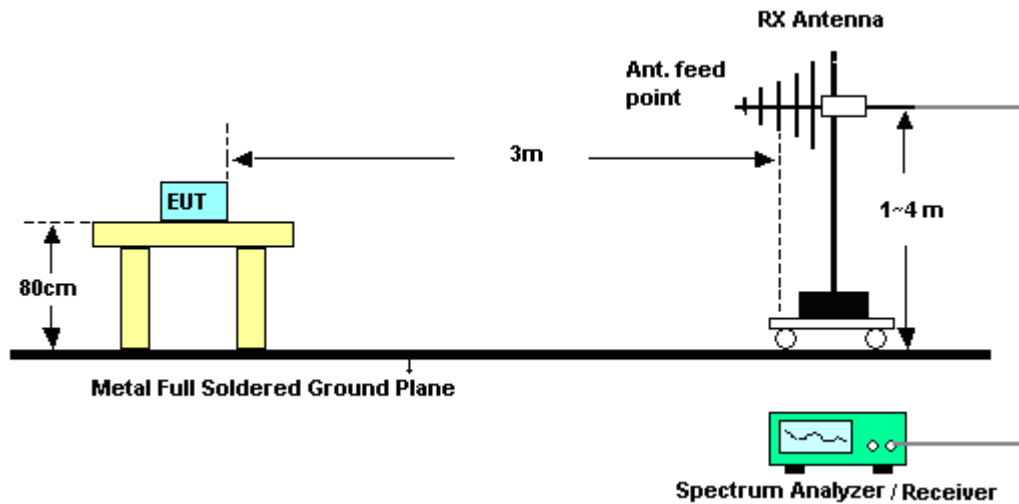

For radiated emissions above 1GHz

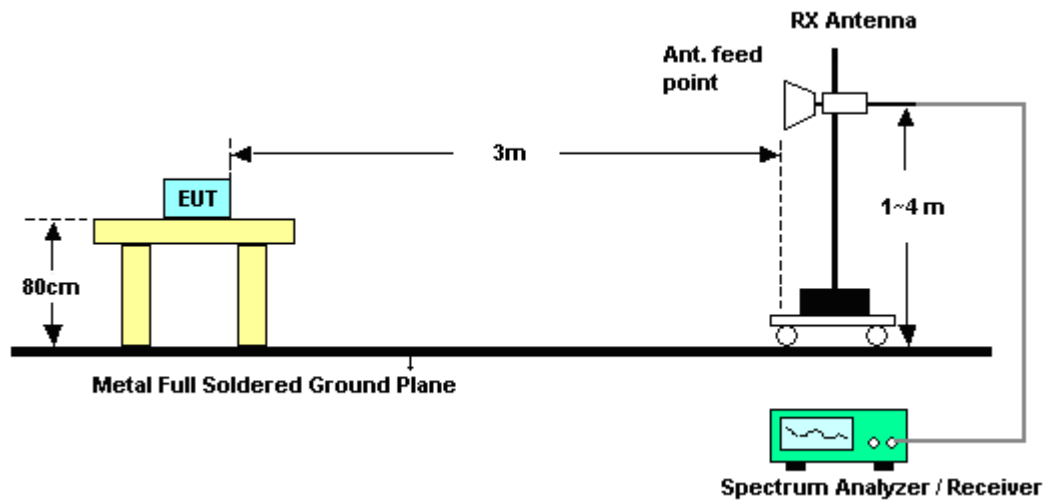

3.5.5 Test Results of Radiated Emissions (9 KHz ~ 30 MHz)

The low frequency, which started from 9 KHz to 30MHz, was pre-scanned and the result which was 20dB lower than the limit line per 15.31(o) was not reported.



3.5.6 Test Result of Radiated Band Edges

Test Mode :	802.11b	Temperature :	22~23°C
Test Band :	Low	Relative Humidity :	41~42%
Test Channel :	01	Test Engineer :	Steven Hao

ANTENNA POLARITY : HORIZONTAL										
Frequency (MHz)	Level (dBµV/m)	Over Limit (dB)	Limit Line (dBµV/m)	Read Level (dBµV)	Antenna Factor (dB)	Cable Loss (dB)	Preamp Factor (dB)	Ant Pos (cm)	Table Pos (deg)	Remark
2389.29	53.25	-20.75	74	49.79	32.86	2.11	31.51	100	20	Peak
2390	42.29	-11.71	54	38.83	32.86	2.11	31.51	100	20	Average

ANTENNA POLARITY : VERTICAL										
Frequency (MHz)	Level (dBµV/m)	Over Limit (dB)	Limit Line (dBµV/m)	Read Level (dBµV)	Antenna Factor (dB)	Cable Loss (dB)	Preamp Factor (dB)	Ant Pos (cm)	Table Pos (deg)	Remark
2389.2	50.52	-23.48	74	47.06	32.86	2.11	31.51	120	0	Peak
2389.74	38.07	-15.93	54	34.61	32.86	2.11	31.51	120	0	Average

Test Mode :	802.11b	Temperature :	22~23°C
Test Band :	High	Relative Humidity :	41~42%
Test Channel :	11	Test Engineer :	Steven Hao

ANTENNA POLARITY : HORIZONTAL										
Frequency (MHz)	Level (dBµV/m)	Over Limit (dB)	Limit Line (dBµV/m)	Read Level (dBµV)	Antenna Factor (dB)	Cable Loss (dB)	Preamp Factor (dB)	Ant Pos (cm)	Table Pos (deg)	Remark
2483.71	52.55	-21.45	74	48.89	33.01	2.16	31.51	100	25	Peak
2483.5	41.2	-12.8	54	37.54	33.01	2.16	31.51	100	25	Average

ANTENNA POLARITY : VERTICAL										
Frequency (MHz)	Level (dBµV/m)	Over Limit (dB)	Limit Line (dBµV/m)	Read Level (dBµV)	Antenna Factor (dB)	Cable Loss (dB)	Preamp Factor (dB)	Ant Pos (cm)	Table Pos (deg)	Remark
2486.14	50.9	-23.1	74	47.24	33.01	2.16	31.51	106	160	Peak
2483.5	37.65	-16.35	54	33.99	33.01	2.16	31.51	106	160	Average



Test Mode :	802.11g	Temperature :	22~23°C
Test Band :	Low	Relative Humidity :	41~42%
Test Channel :	01	Test Engineer :	Steven Hao

ANTENNA POLARITY : HORIZONTAL										
Frequency (MHz)	Level (dBμV/m)	Over Limit (dB)	Limit Line (dBμV/m)	Read Level (dBμV)	Antenna Factor (dB)	Cable Loss (dB)	Preamp Factor (dB)	Ant Pos (cm)	Table Pos (deg)	Remark
2390	64.87	-9.13	74	61.41	32.86	2.11	31.51	100	345	Peak
2390	48.95	-5.05	54	45.49	32.86	2.11	31.51	100	345	Average

ANTENNA POLARITY : VERTICAL										
Frequency (MHz)	Level (dBμV/m)	Over Limit (dB)	Limit Line (dBμV/m)	Read Level (dBμV)	Antenna Factor (dB)	Cable Loss (dB)	Preamp Factor (dB)	Ant Pos (cm)	Table Pos (deg)	Remark
2390	55.47	-18.53	74	52.01	32.86	2.11	31.51	100	161	Peak
2390	40.03	-13.97	54	36.57	32.86	2.11	31.51	100	161	Average

Test Mode :	802.11g	Temperature :	22~23°C
Test Band :	High	Relative Humidity :	41~42%
Test Channel :	11	Test Engineer :	Steven Hao

ANTENNA POLARITY : HORIZONTAL										
Frequency (MHz)	Level (dBμV/m)	Over Limit (dB)	Limit Line (dBμV/m)	Read Level (dBμV)	Antenna Factor (dB)	Cable Loss (dB)	Preamp Factor (dB)	Ant Pos (cm)	Table Pos (deg)	Remark
2483.59	60.32	-13.68	74	56.66	33.01	2.16	31.51	100	342	Peak
2483.53	43.75	-10.25	54	40.09	33.01	2.16	31.51	100	342	Average

ANTENNA POLARITY : VERTICAL										
Frequency (MHz)	Level (dBμV/m)	Over Limit (dB)	Limit Line (dBμV/m)	Read Level (dBμV)	Antenna Factor (dB)	Cable Loss (dB)	Preamp Factor (dB)	Ant Pos (cm)	Table Pos (deg)	Remark
2483.5	56.09	-17.91	74	52.43	33.01	2.16	31.51	100	151	Peak
2483.71	40.91	-13.09	54	37.25	33.01	2.16	31.51	100	151	Average



Test Mode :	802.11n HT20	Temperature :	22~23°C
Test Band :	Low	Relative Humidity :	41~42%
Test Channel :	01	Test Engineer :	Steven Hao

ANTENNA POLARITY : HORIZONTAL										
Frequency (MHz)	Level (dBμV/m)	Over Limit (dB)	Limit Line (dBμV/m)	Read Level (dBμV)	Antenna Factor (dB)	Cable Loss (dB)	Preamp Factor (dB)	Ant Pos (cm)	Table Pos (deg)	Remark
2390	67.48	-6.52	74	64.02	32.86	2.11	31.51	100	0	Peak
2390	47.35	-6.65	54	43.89	32.86	2.11	31.51	100	0	Average

ANTENNA POLARITY : VERTICAL										
Frequency (MHz)	Level (dBμV/m)	Over Limit (dB)	Limit Line (dBμV/m)	Read Level (dBμV)	Antenna Factor (dB)	Cable Loss (dB)	Preamp Factor (dB)	Ant Pos (cm)	Table Pos (deg)	Remark
2390	60.01	-13.99	74	56.55	32.86	2.11	31.51	168	0	Peak
2390	40.9	-13.1	54	37.44	32.86	2.11	31.51	168	0	Average

Test Mode :	802.11n HT20	Temperature :	22~23°C
Test Band :	High	Relative Humidity :	41~42%
Test Channel :	11	Test Engineer :	Steven Hao

ANTENNA POLARITY : HORIZONTAL										
Frequency (MHz)	Level (dBμV/m)	Over Limit (dB)	Limit Line (dBμV/m)	Read Level (dBμV)	Antenna Factor (dB)	Cable Loss (dB)	Preamp Factor (dB)	Ant Pos (cm)	Table Pos (deg)	Remark
2483.5	61.78	-12.22	74	58.12	33.01	2.16	31.51	100	360	Peak
2483.5	44.36	-9.64	54	40.7	33.01	2.16	31.51	100	360	Average

ANTENNA POLARITY : VERTICAL										
Frequency (MHz)	Level (dBμV/m)	Over Limit (dB)	Limit Line (dBμV/m)	Read Level (dBμV)	Antenna Factor (dB)	Cable Loss (dB)	Preamp Factor (dB)	Ant Pos (cm)	Table Pos (deg)	Remark
2483.5	54.09	-19.91	74	50.43	33.01	2.16	31.51	154	63	Peak
2483.5	38.45	-15.55	54	34.79	33.01	2.16	31.51	154	63	Average



3.5.7 Test Result of Radiated Emission (30 MHz ~ 10th Harmonic)

NOTE: Below 1GHz for radiated emission measurement, pre-scanned all test modes and only choose the worst case mode was recorded in the report.

Test Mode :	802.11b	Temperature :	22~23°C
Test Channel :	01	Relative Humidity :	41~42%
Test Engineer :	Steven Hao	Polarization :	Horizontal
Remark :	1. 2412 MHz is fundamental signal which can be ignored. 2. 7236 MHz is not within a restricted band, and its limit line is 20dB below the highest emission level. 3. Average measurement was not performed if peak level went lower than the average limit. Peak		

Frequency (MHz)	Level (dBμV/m)	Over Limit (dB)	Limit Line (dBμV/m)	Read Level (dBμV)	Antenna Factor (dB)	Cable Loss (dB)	Preamp Factor (dB)	Ant Pos (cm)	Table Pos (deg)	Remark
2397.03	65.9	-21.75	87.65	62.44	32.86	2.11	31.51	100	20	Peak
2412	107.65	-	-	104.15	32.89	2.12	31.51	100	20	Peak
2412	98.81	-	-	95.31	32.89	2.12	31.51	100	20	Average
4824	49.77	-24.23	74	43.04	35.17	3.09	31.53	120	360	Peak
7236	51.83	-35.82	87.65	43.36	36.18	3.24	30.95	120	0	Peak



Test Mode :	802.11b	Temperature :	22~23°C
Test Channel :	01	Relative Humidity :	41~42%
Test Engineer :	Steven Hao	Polarization :	Vertical
Remark :	1. 2412 MHz is fundamental signal which can be ignored. 2. 7236 MHz is not within a restricted band, and its limit line is 20dB below the highest emission level. 3. Average measurement was not performed if peak level went lower than the average limit. Peak		

Frequency (MHz)	Level (dBμV/m)	Over Limit (dB)	Limit Line (dBμV/m)	Read Level (dBμV)	Antenna Factor (dB)	Cable Loss (dB)	Preamp Factor (dB)	Ant Pos (cm)	Table Pos (deg)	Remark
2397.66	56.94	-22.25	79.19	53.48	32.86	2.11	31.51	120	0	Peak
2412	99.19	-	-	95.69	32.89	2.12	31.51	120	0	Peak
2412	90.38	-	-	86.88	32.89	2.12	31.51	120	0	Average
4824	50.37	-23.63	74	43.64	35.17	3.09	31.53	200	156	Peak
7236	51.94	-27.25	79.19	43.47	36.18	3.24	30.95	100	35	Peak



Test Mode :	802.11b	Temperature :	22~23°C
Test Channel :	06	Relative Humidity :	41~42%
Test Engineer :	Steven Hao	Polarization :	Horizontal
Remark :	1. 2437 MHz is fundamental signal which can be ignored. 2. Average measurement was not performed if peak level went lower than the average limit. Peak		

Frequency (MHz)	Level (dBμV/m)	Over Limit (dB)	Limit Line (dBμV/m)	Read Level (dBμV)	Antenna Factor (dB)	Cable Loss (dB)	Preamp Factor (dB)	Ant Pos (cm)	Table Pos (deg)	Remark
2437	106.88	-	-	103.3	32.95	2.14	31.51	100	7	Peak
2437	97.76	-	-	94.18	32.95	2.14	31.51	100	7	Average
4874	49.26	-24.74	74	42.48	35.18	3.12	31.52	100	0	Peak
7312	50.74	-23.26	74	42.27	36.2	3.21	30.94	169	248	Peak

Test Mode :	802.11b	Temperature :	22~23°C
Test Channel :	06	Relative Humidity :	41~42%
Test Engineer :	Steven Hao	Polarization :	Vertical
Remark :	1. 2437 MHz is fundamental signal which can be ignored. 2. Average measurement was not performed if peak level went lower than the average limit. Peak		

Frequency (MHz)	Level (dBμV/m)	Over Limit (dB)	Limit Line (dBμV/m)	Read Level (dBμV)	Antenna Factor (dB)	Cable Loss (dB)	Preamp Factor (dB)	Ant Pos (cm)	Table Pos (deg)	Remark
2437	96.82	-	-	93.24	32.95	2.14	31.51	100	186	Peak
2437	87.92	-	-	84.34	32.95	2.14	31.51	100	186	Average
4874	49.07	-24.93	74	42.29	35.18	3.12	31.52	100	0	Peak
7312	50.37	-23.63	74	41.9	36.2	3.21	30.94	120	100	Peak



Test Mode :	802.11b	Temperature :	22~23°C
Test Channel :	11	Relative Humidity :	41~42%
Test Engineer :	Steven Hao	Polarization :	Horizontal
Remark :	1. 2462 MHz is fundamental signal which can be ignored. 2. Average measurement was not performed if peak level went lower than the average limit. Peak		

Frequency (MHz)	Level (dBμV/m)	Over Limit (dB)	Limit Line (dBμV/m)	Read Level (dBμV)	Antenna Factor (dB)	Cable Loss (dB)	Preamp Factor (dB)	Ant Pos (cm)	Table Pos (deg)	Remark
2462	107.27	-	-	103.65	32.98	2.15	31.51	100	19	Peak
2462	97.78	-	-	94.16	32.98	2.15	31.51	100	19	Average
4924	50.19	-23.81	74	43.36	35.19	3.15	31.51	100	0	Peak
7386	51.36	-22.64	74	42.86	36.24	3.19	30.93	136	200	Peak

Test Mode :	802.11b	Temperature :	22~23°C
Test Channel :	11	Relative Humidity :	41~42%
Test Engineer :	Steven Hao	Polarization :	Vertical
Remark :	1. 2462 MHz is fundamental signal which can be ignored. 2. Average measurement was not performed if peak level went lower than the average limit. Peak		

Frequency (MHz)	Level (dBμV/m)	Over Limit (dB)	Limit Line (dBμV/m)	Read Level (dBμV)	Antenna Factor (dB)	Cable Loss (dB)	Preamp Factor (dB)	Ant Pos (cm)	Table Pos (deg)	Remark
2462	97.27	-	-	93.65	32.98	2.15	31.51	104	154	Peak
2462	88.23	-	-	84.61	32.98	2.15	31.51	104	154	Average
4924	49.16	-24.84	74	42.33	35.19	3.15	31.51	100	50	Peak
7386	51.08	-22.92	74	42.58	36.24	3.19	30.93	100	200	Peak



Test Mode :	802.11g	Temperature :	22~23°C
Test Channel :	01	Relative Humidity :	41~42%
Test Engineer :	Steven Hao	Polarization :	Horizontal
Remark :	1. 2412 MHz is fundamental signal which can be ignored. 2. 7236 MHz is not within a restricted band, and its limit line is 20dB below the highest emission level. 3. Average measurement was not performed if peak level went lower than the average limit. Peak		

Frequency (MHz)	Level (dBμV/m)	Over Limit (dB)	Limit Line (dBμV/m)	Read Level (dBμV)	Antenna Factor (dB)	Cable Loss (dB)	Preamp Factor (dB)	Ant Pos (cm)	Table Pos (deg)	Remark
30.531	18.95	-21.05	40	34.9	17.29	0.34	33.58	-	-	Peak
71.581	16.8	-23.2	40	44.4	5.46	0.53	33.59	-	-	Peak
129.015	16.29	-27.21	43.5	37.5	11.71	0.67	33.59	-	-	Peak
211.527	14.82	-28.68	43.5	37.98	9.54	0.84	33.54	-	-	Peak
441.743	17.92	-28.08	46	33.69	16.26	1.19	33.22	-	-	Peak
942.131	30.32	-15.68	46	40.31	20.7	1.75	32.44	100	126	Peak
2399	76.33	-6.94	83.27	72.87	32.86	2.11	31.51	100	345	Peak
2412	103.27	-	-	99.77	32.89	2.12	31.51	100	346	Peak
2412	91.15	-	-	87.65	32.89	2.12	31.51	100	346	Average
4824	49	-25	74	42.27	35.17	3.09	31.53	100	16	Peak
7236	50.56	-32.71	83.27	42.09	36.18	3.24	30.95	100	101	Peak



Test Mode :	802.11g	Temperature :	22~23°C
Test Channel :	01	Relative Humidity :	41~42%
Test Engineer :	Steven Hao	Polarization :	Vertical
Remark :	1. 2412 MHz is fundamental signal which can be ignored. 2. 7236 MHz is not within a restricted band, and its limit line is 20dB below the highest emission level. 3. Average measurement was not performed if peak level went lower than the average limit. Peak		

Frequency (MHz)	Level (dBμV/m)	Over Limit (dB)	Limit Line (dBμV/m)	Read Level (dBμV)	Antenna Factor (dB)	Cable Loss (dB)	Preamp Factor (dB)	Ant Pos (cm)	Table Pos (deg)	Remark
47.826	23.61	-16.39	40	48.28	8.5	0.43	33.6	-	-	Peak
100.934	22.43	-21.07	43.5	44.84	10.62	0.58	33.61	-	-	Peak
129.015	19.56	-23.94	43.5	40.77	11.71	0.67	33.59	-	-	Peak
226.099	18.12	-27.88	46	40.16	10.59	0.87	33.5	-	-	Peak
824.597	28.61	-17.39	46	39.49	20.16	1.64	32.68	-	-	Peak
942.131	30.2	-15.8	46	40.19	20.7	1.75	32.44	100	112	Peak
2398.02	66.75	-9.1	75.85	63.29	32.86	2.11	31.51	100	161	Peak
2412	95.85	-	-	92.35	32.89	2.12	31.51	140	326	Peak
2412	83.76	-	-	80.26	32.89	2.12	31.51	140	326	Average
4824	49.06	-24.94	74	42.33	35.17	3.09	31.53	100	62	Peak
7236	49.96	-25.89	75.85	41.49	36.18	3.24	30.95	100	105	Peak



Test Mode :	802.11g	Temperature :	22~23°C
Test Channel :	06	Relative Humidity :	41~42%
Test Engineer :	Steven Hao	Polarization :	Horizontal
Remark :	1. 2437 MHz is fundamental signal which can be ignored. 2. Average measurement was not performed if peak level went lower than the average limit. Peak		

Frequency (MHz)	Level (dBμV/m)	Over Limit (dB)	Limit Line (dBμV/m)	Read Level (dBμV)	Antenna Factor (dB)	Cable Loss (dB)	Preamp Factor (dB)	Ant Pos (cm)	Table Pos (deg)	Remark
2437	102.6	-	-	99.02	32.95	2.14	31.51	100	344	Peak
2437	91.2	-	-	87.62	32.95	2.14	31.51	100	344	Average
4874	49.68	-24.32	74	42.9	35.18	3.12	31.52	100	0	Peak
7311	50.04	-23.96	74	41.57	36.2	3.21	30.94	100	26	Peak

Test Mode :	802.11g	Temperature :	22~23°C
Test Channel :	06	Relative Humidity :	41~42%
Test Engineer :	Steven Hao	Polarization :	Vertical
Remark :	1. 2437 MHz is fundamental signal which can be ignored. 2. Average measurement was not performed if peak level went lower than the average limit. Peak		

Frequency (MHz)	Level (dBμV/m)	Over Limit (dB)	Limit Line (dBμV/m)	Read Level (dBμV)	Antenna Factor (dB)	Cable Loss (dB)	Preamp Factor (dB)	Ant Pos (cm)	Table Pos (deg)	Remark
2437	94.15	-	-	90.57	32.95	2.14	31.51	100	321	Peak
2437	82.23	-	-	78.65	32.95	2.14	31.51	100	321	Average
4874	48.92	-25.08	74	42.14	35.18	3.12	31.52	100	196	Peak
7311	50.02	-23.98	74	41.55	36.2	3.21	30.94	100	90	Peak



Test Mode :	802.11g	Temperature :	22~23°C
Test Channel :	11	Relative Humidity :	41~42%
Test Engineer :	Steven Hao	Polarization :	Horizontal
Remark :	1. 2462 MHz is fundamental signal which can be ignored. 2. Average measurement was not performed if peak level went lower than the average limit. Peak		

Frequency (MHz)	Level (dBμV/m)	Over Limit (dB)	Limit Line (dBμV/m)	Read Level (dBμV)	Antenna Factor (dB)	Cable Loss (dB)	Preamp Factor (dB)	Ant Pos (cm)	Table Pos (deg)	Remark
2462	104.17	-	-	100.55	32.98	2.15	31.51	100	345	Peak
2462	92.53	-	-	88.91	32.98	2.15	31.51	100	345	Average
4924	49.37	-24.63	74	42.54	35.19	3.15	31.51	100	25	Peak
7386	49.78	-24.22	74	41.28	36.24	3.19	30.93	100	18	Peak

Test Mode :	802.11g	Temperature :	22~23°C
Test Channel :	11	Relative Humidity :	41~42%
Test Engineer :	Steven Hao	Polarization :	Vertical
Remark :	1. 2462 MHz is fundamental signal which can be ignored. 2. Average measurement was not performed if peak level went lower than the average limit. Peak		

Frequency (MHz)	Level (dBμV/m)	Over Limit (dB)	Limit Line (dBμV/m)	Read Level (dBμV)	Antenna Factor (dB)	Cable Loss (dB)	Preamp Factor (dB)	Ant Pos (cm)	Table Pos (deg)	Remark
2462	95.65	-	-	92.03	32.98	2.15	31.51	100	191	Peak
2462	84.23	-	-	80.61	32.98	2.15	31.51	100	191	Average
4924	48.61	-25.39	74	41.78	35.19	3.15	31.51	100	151	Peak
7386	50.79	-23.21	74	42.29	36.24	3.19	30.93	100	32	Peak



Test Mode :	802.11n HT20	Temperature :	22~23°C
Test Channel :	01	Relative Humidity :	41~42%
Test Engineer :	Steven Hao	Polarization :	Horizontal
Remark :	1. 2412 MHz is fundamental signal which can be ignored. 2. 7236 MHz is not within a restricted band, and its limit line is 20dB below the highest emission level. 3. Average measurement was not performed if peak level went lower than the average limit. Peak		

Frequency (MHz)	Level (dBμV/m)	Over Limit (dB)	Limit Line (dBμV/m)	Read Level (dBμV)	Antenna Factor (dB)	Cable Loss (dB)	Preamp Factor (dB)	Ant Pos (cm)	Table Pos (deg)	Remark
2399	73.71	-8.88	82.59	70.25	32.86	2.11	31.51	100	0	Peak
2412	102.59	-	-	99.09	32.89	2.12	31.51	100	355	Peak
2412	91.72	-	-	88.22	32.89	2.12	31.51	100	355	Average
4824	48.67	-25.33	74	41.94	35.17	3.09	31.53	100	268	Peak
7236	50.5	-32.09	82.59	42.03	36.18	3.24	30.95	102	34	Peak

Test Mode :	802.11n HT20	Temperature :	22~23°C
Test Channel :	01	Relative Humidity :	41~42%
Test Engineer :	Steven Hao	Polarization :	Vertical
Remark :	1. 2412 MHz is fundamental signal which can be ignored. 2. 7236 MHz is not within a restricted band, and its limit line is 20dB below the highest emission level. 3. Average measurement was not performed if peak level went lower than the average limit. Peak		

Frequency (MHz)	Level (dBμV/m)	Over Limit (dB)	Limit Line (dBμV/m)	Read Level (dBμV)	Antenna Factor (dB)	Cable Loss (dB)	Preamp Factor (dB)	Ant Pos (cm)	Table Pos (deg)	Remark
2399	65.81	-4.73	70.54	62.35	32.86	2.11	31.51	168	0	Peak
2412	90.54	-	-	87.04	32.89	2.12	31.51	200	340	Peak
2412	79.48	-	-	75.98	32.89	2.12	31.51	200	340	Average
4824	49.12	-24.88	74	42.39	35.17	3.09	31.53	100	256	Peak
7236	50.02	-20.52	70.54	41.55	36.18	3.24	30.95	100	0	Peak



Test Mode :	802.11n HT20	Temperature :	22~23°C
Test Channel :	06	Relative Humidity :	41~42%
Test Engineer :	Steven Hao	Polarization :	Horizontal
Remark :	1. 2437 MHz is fundamental signal which can be ignored. 2. Average measurement was not performed if peak level went lower than the average limit. Peak		

Frequency (MHz)	Level (dBμV/m)	Over Limit (dB)	Limit Line (dBμV/m)	Read Level (dBμV)	Antenna Factor (dB)	Cable Loss (dB)	Preamp Factor (dB)	Ant Pos (cm)	Table Pos (deg)	Remark
2437	101.21	-	-	97.63	32.95	2.14	31.51	100	360	Peak
2437	90.58	-	-	87	32.95	2.14	31.51	100	360	Average
4874	48.76	-25.24	74	41.98	35.18	3.12	31.52	100	157	Peak
7311	50.02	-23.98	74	41.55	36.2	3.21	30.94	102	57	Peak

Test Mode :	802.11n HT20	Temperature :	22~23°C
Test Channel :	06	Relative Humidity :	41~42%
Test Engineer :	Steven Hao	Polarization :	Vertical
Remark :	1. 2437 MHz is fundamental signal which can be ignored. 2. Average measurement was not performed if peak level went lower than the average limit. Peak		

Frequency (MHz)	Level (dBμV/m)	Over Limit (dB)	Limit Line (dBμV/m)	Read Level (dBμV)	Antenna Factor (dB)	Cable Loss (dB)	Preamp Factor (dB)	Ant Pos (cm)	Table Pos (deg)	Remark
2437	92.83	-	-	89.25	32.95	2.14	31.51	169	360	Peak
2437	82.07	-	-	78.49	32.95	2.14	31.51	169	360	Average
4874	49.33	-24.67	74	42.55	35.18	3.12	31.52	102	360	Peak
7311	50	-24	74	41.53	36.2	3.21	30.94	100	0	Peak



Test Mode :	802.11n HT20	Temperature :	22~23°C
Test Channel :	11	Relative Humidity :	41~42%
Test Engineer :	Steven Hao	Polarization :	Horizontal
Remark :	1. 2462 MHz is fundamental signal which can be ignored. 2. Average measurement was not performed if peak level went lower than the average limit. Peak		

Frequency (MHz)	Level (dBμV/m)	Over Limit (dB)	Limit Line (dBμV/m)	Read Level (dBμV)	Antenna Factor (dB)	Cable Loss (dB)	Preamp Factor (dB)	Ant Pos (cm)	Table Pos (deg)	Remark
2462	100.77	-	-	97.15	32.98	2.15	31.51	100	360	Peak
2462	90.57	-	-	86.95	32.98	2.15	31.51	100	360	Average
4924	48.7	-25.3	74	41.87	35.19	3.15	31.51	100	236	Peak
7386	50.12	-23.88	74	41.62	36.24	3.19	30.93	102	68	Peak

Test Mode :	802.11n HT20	Temperature :	22~23°C
Test Channel :	11	Relative Humidity :	41~42%
Test Engineer :	Steven Hao	Polarization :	Vertical
Remark :	1. 2462 MHz is fundamental signal which can be ignored. 2. Average measurement was not performed if peak level went lower than the average limit. Peak		

Frequency (MHz)	Level (dBμV/m)	Over Limit (dB)	Limit Line (dBμV/m)	Read Level (dBμV)	Antenna Factor (dB)	Cable Loss (dB)	Preamp Factor (dB)	Ant Pos (cm)	Table Pos (deg)	Remark
2462	92.16	-	-	88.54	32.98	2.15	31.51	180	338	Peak
2462	81.45	-	-	77.83	32.98	2.15	31.51	180	338	Average
4924	47.92	-26.08	74	41.09	35.19	3.15	31.51	100	200	Peak
7386	49.83	-24.17	74	41.33	36.24	3.19	30.93	101	48	Peak

3.6 AC Conducted Emission Measurement

3.6.1 Limit of AC Conducted Emission

For equipment that is designed to be connected to the public utility (AC) power line, the radio frequency voltage that is conducted back onto the AC power line on any frequency or frequencies within the band 150 KHz to 30 MHz shall not exceed the limits in the following table.

Frequency of Emission (MHz)	Conducted Limit (dBuV)	
	Quasi-Peak	Average
0.15-0.5	66 to 56*	56 to 46*
0.5-5	56	46
5-30	60	50

*Decreases with the logarithm of the frequency.

3.6.2 Measuring Instruments

See list of measuring instruments of this test report.

3.6.3 Test Procedures

1. The testing follows the guidelines in ANSI C63.4-2003 and ANSI C63.10-2009.
2. The EUT was placed 0.4 meter from the conducting wall of the shielding room, and it was kept at least 80 centimeters from any other grounded conducting surface.
3. Connect EUT to the power mains through a line impedance stabilization network (LISN).
4. All the support units are connecting to the other LISN.
5. The LISN provides 50 ohm coupling impedance for the measuring instrument.
6. The FCC states that a 50 ohm, 50 microhenry LISN should be used.
7. Both sides of AC line were checked for maximum conducted interference.
8. The frequency range from 150 KHz to 30 MHz was searched.
9. Set the test-receiver system to Peak Detect Function and specified bandwidth with Maximum Hold Mode.

3.6.4 Test Setup

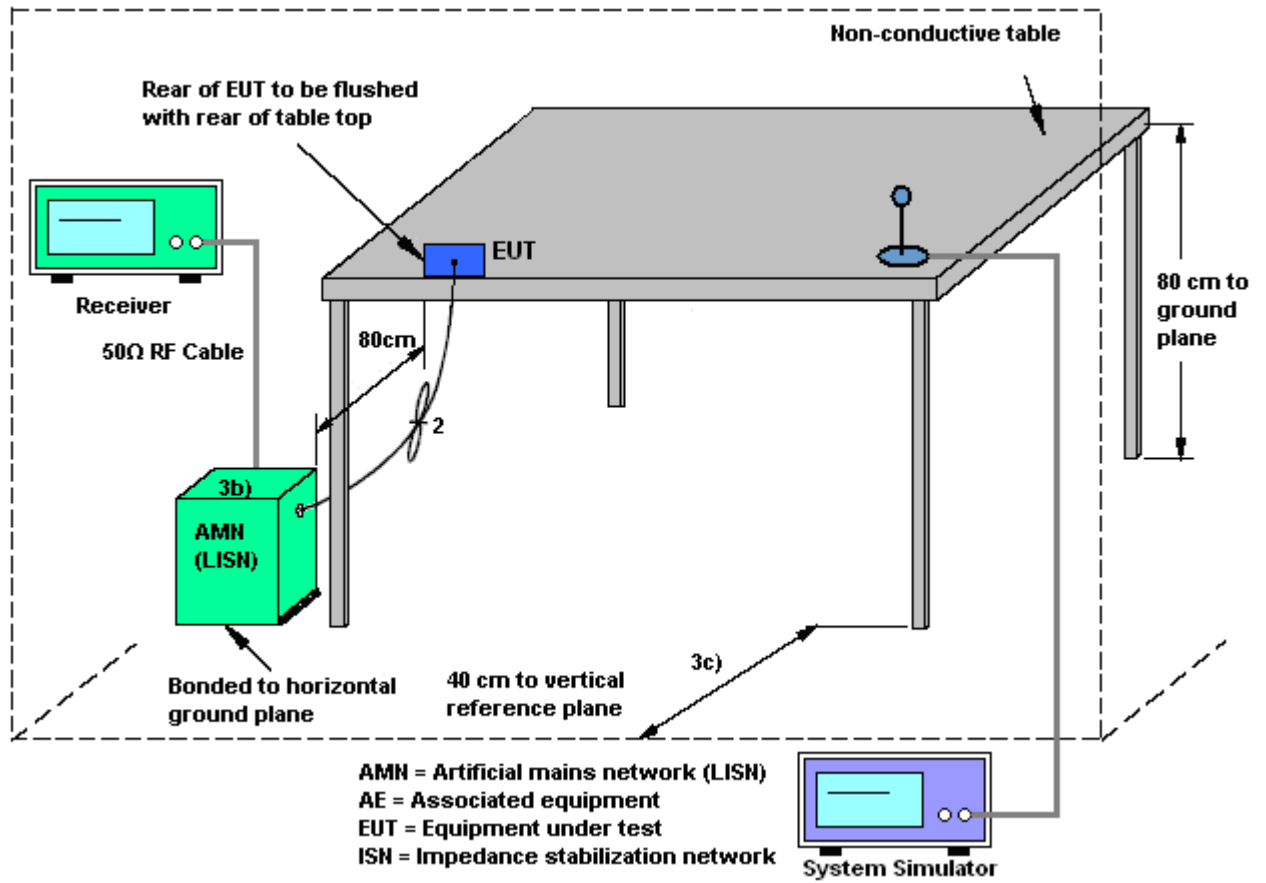



3.6.5 Test Result of AC Conducted Emission

Test Mode :	Mode 1	Temperature :	19~20°C
Test Engineer :	Tom Wang	Relative Humidity :	39~40%
Test Voltage :	120Vac / 60Hz	Phase :	Line
Function Type :	CDMA2000 BC0 Idle + WLAN Link + Bluetooth Link + USB Cable (Charging from Adapter) + Earphone		
Remark :	All emissions not reported here are more than 10 dB below the prescribed limit.		

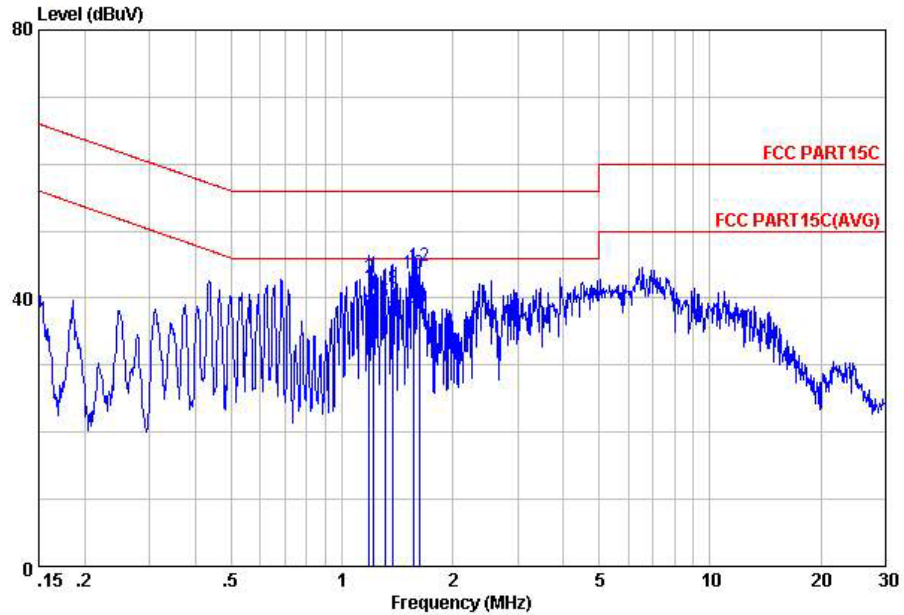

Site : C001-KS
 Condition: FCC PART15C LISN-111230 LINE

	Freq	Level	Over	Limit	Read	LISN	Cable	
	MHz	dBuV	Limit	Line	Level	Factor	Loss	Remark
			dB	dBuV	dBuV	dB	dB	
1	1.18	37.98	-8.02	46.00	27.80	-0.10	10.28	Average
2	1.18	42.98	-13.02	56.00	32.80	-0.10	10.28	QP
3	1.22	38.78	-7.22	46.00	28.60	-0.10	10.28	Average
4	1.22	40.48	-15.52	56.00	30.30	-0.10	10.28	QP
5	1.31	39.38	-16.62	56.00	29.19	-0.10	10.29	QP
6	1.31	34.88	-11.12	46.00	24.69	-0.10	10.29	Average
7	1.37	36.68	-9.32	46.00	26.49	-0.10	10.29	Average
8	1.37	41.38	-14.62	56.00	31.19	-0.10	10.29	QP
9	1.56	38.49	-7.51	46.00	28.31	-0.11	10.29	Average
10	1.56	43.79	-12.21	56.00	33.61	-0.11	10.29	QP
11	1.62	38.69	-7.31	46.00	28.50	-0.11	10.30	Average
12	1.62	44.89	-11.11	56.00	34.70	-0.11	10.30	QP



Test Mode :	Mode 1	Temperature :	19~20°C
Test Engineer :	Tom Wang	Relative Humidity :	39~40%
Test Voltage :	120Vac / 60Hz	Phase :	Neutral
Function Type :	CDMA2000 BC0 Idle + WLAN Link + Bluetooth Link + USB Cable (Charging from Adapter) + Earphone		
Remark :	All emissions not reported here are more than 10 dB below the prescribed limit.		

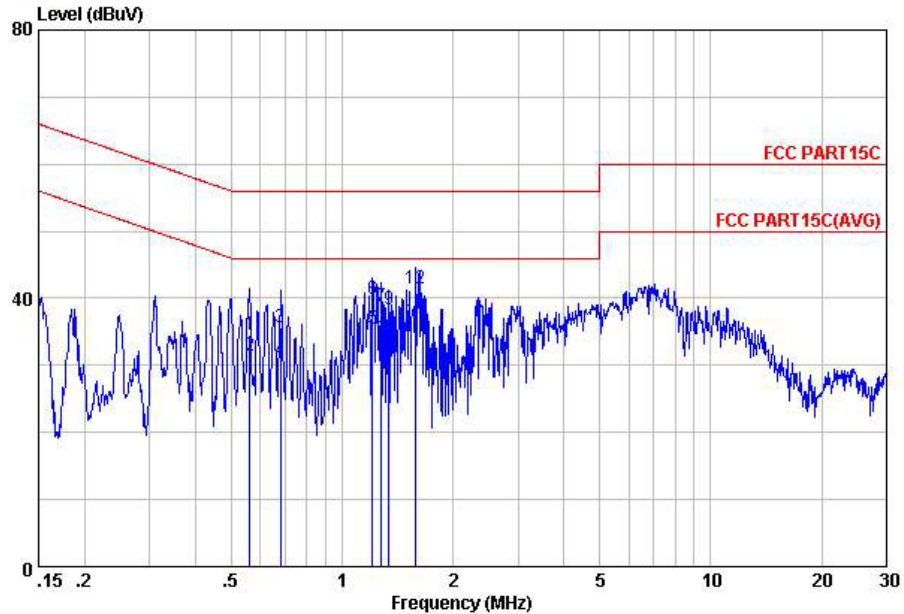

Site : C001-KS
 Condition: FCC PART15C LISN-111230 NEUTRAL

	Freq	Level	Over	Limit	Read	LISN	Cable	Remark
	MHz	dBuV	Limit	Line	Level	Factor	Loss	
			dB	dBuV	dBuV	dB	dB	
1	0.56	34.58	-21.42	56.00	24.40	-0.08	10.26	QP
2	0.56	31.48	-14.52	46.00	21.30	-0.08	10.26	Average
3	0.68	35.59	-20.41	56.00	25.40	-0.08	10.27	QP
4	0.68	30.79	-15.21	46.00	20.60	-0.08	10.27	Average
5	1.21	35.49	-10.51	46.00	25.30	-0.09	10.28	Average
6	1.21	39.99	-16.01	56.00	29.80	-0.09	10.28	QP
7	1.28	38.69	-17.31	56.00	28.50	-0.10	10.29	QP
8	1.28	33.79	-12.21	46.00	23.60	-0.10	10.29	Average
9	1.34	38.29	-17.71	56.00	28.10	-0.10	10.29	QP
10	1.34	33.39	-12.61	46.00	23.20	-0.10	10.29	Average
11	1.59	36.49	-9.51	46.00	26.30	-0.10	10.29	Average
12	1.59	41.49	-14.51	56.00	31.30	-0.10	10.29	QP



3.7 Antenna Requirements

3.7.1 Standard Applicable

If directional gain of transmitting antennas is greater than 6dBi, the power shall be reduced by the same level in dB comparing to gain minus 6dBi. For the fixed point-to-point operation, the power shall be reduced by one dB for every 3 dB that the directional gain of the antenna exceeds 6 dBi. The use of a permanently attached antenna or of an antenna that uses a unique coupling to the intentional radiator shall be considered sufficient to comply with the FCC rule.

3.7.2 Antenna Connected Construction

Non-standard connector used.

3.7.3 Antenna Gain

The antenna peak gain of EUT is less than 6 dBi. Therefore, it is not necessary to reduce maximum peak output power limit.

4 List of Measuring Equipment

Instrument	Manufacturer	Model No.	Serial No.	Characteristics	Calibration Date	Test Date	Due Date	Remark
Spectrum Analyzer	R&S	FSP40	100319	9kHz~40GHz	Dec. 29, 2012	Dec. 14, 2012~ Jan. 08, 2013	Dec. 28, 2013	Conducted (TH01-KS)
Power Meter	Agilent	E4416A	MY45101555	N/A	Aug. 22, 2012	Dec. 14, 2012~ Jan. 08, 2013	Aug. 21, 2013	Conducted (TH01-KS)
Power Sensor	Agilent	E9327A	MY44421198	N/A	Aug. 22, 2012	Dec. 14, 2012~ Jan. 08, 2013	Aug. 21, 2013	Conducted (TH01-KS)
DC Power Supply	GWINSTEK	GPS-3030D	E1884515	N/A	Aug. 22, 2012	Dec. 14, 2012~ Jan. 08, 2013	Aug. 21, 2013	Conducted (TH01-KS)
Thermal Chamber	Ten Billion	TTC-B3S	TBN-960502	N/A	Dec. 29, 2012	Dec. 14, 2012~ Jan. 08, 2013	Dec. 28, 2013	Conducted (TH01-KS)
EMI Test Receiver	R&S	ESCI	100534	9kHz~3GHz	Nov. 08, 2012	Dec. 30, 2012	Nov. 07, 2013	Radiation (03CH01-KS)
Spectrum Analyzer	R&S	FSP30	100400	9kHz~30GHz	Jun. 01, 2012	Dec. 30, 2012	May 31, 2013	Radiation (03CH01-KS)
Bilog Antenna	SCHAFFNER	CBL6112D	23182	25MHz~2GHz	Dec. 07, 2012	Dec. 30, 2012	Dec. 06, 2013	Radiation (03CH01-KS)
Loop Antenna	R&S	HFH2-Z2	860004/ 001	9 kHz~30 MHz	Jul. 03, 2012	Dec. 30, 2012	Jul. 02, 2014	Radiation (03CH01-KS)
Double Ridge Horn Antenna	EMCO	3117	00075959	1GHz~18GHz	Jan. 07, 2012	Dec. 30, 2012	Jan. 06, 2013	Radiation (03CH01-KS)
Amplifier	com-power	PA-103A	161069	1MHz~1GHz	Jun. 01, 2012	Dec. 30, 2012	May 31, 2013	Radiation (03CH01-KS)
Amplifier	Agilent	8449B	3008A02370	1GHz~26.5GHz	Dec. 29, 2012	Dec. 30, 2012	Dec. 28, 2013	Radiation (03CH01-KS)
Active Horn Antenna	com-power	AHA-118	701023	1GHz~18GHz	Nov. 07, 2012	Dec. 30, 2012	Nov. 06, 2013	Radiation (03CH01-KS)
SHF-EHF Horn	Schwarzbeck	BBHA 9170	9170249	15GHz~40GHz	Nov. 23, 2012	Dec. 30, 2012	Nov. 22, 2013	Radiation (03CH01-KS)
EMI Receiver	R&S	ESCI7	100768	9kHz~7GHz	Jun. 01, 2012	Dec. 31, 2012	May 31, 2013	Conduction (CO01-KS)
LISN	MessTec	AN3016	60103	9kHz~30MHz	Dec. 29, 2012	Dec. 31, 2012	Dec. 28, 2013	Conduction (CO01-KS)
LISN	MessTec	AN3016	60105	9kHz~30MHz	Dec. 29, 2012	Dec. 31, 2012	Dec. 28, 2013	Conduction (CO01-KS)
AC Power Source	Chroma	61602	ABP000000811	N/A	Nov. 15, 2012	Dec. 31, 2012	Nov. 14, 2013	Conduction (CO01-KS)
System Simulator	R&S	CMU200	837587/066	2G Full-Band	Dec. 29, 2012	Dec. 31, 2012	Dec. 28, 2013	Conduction (CO01-KS)



5 Uncertainty of Evaluation

Uncertainty of Radiated Emission Measurement (30 MHz ~ 1000 MHz)

Measuring Uncertainty for a Level of Confidence of 95% ($U = 2Uc(y)$)	2.54
---	------

Uncertainty of Radiated Emission Measurement (1 GHz ~ 40 GHz)

Measuring Uncertainty for a Level of Confidence of 95% ($U = 2Uc(y)$)	4.72
---	------

Uncertainty of Conducted Emission Measurement (150 KHz ~ 30 MHz)

Measuring Uncertainty for a Level of Confidence of 95% ($U = 2Uc(y)$)	2.26
---	------



Appendix A. Photographs of EUT

Please refer to Sporton report number EP2D1401 as below.