



# FCC RF Test Report

**APPLICANT** : Unimax Communications  
**EQUIPMENT** : CDMA EVDO REV A 800/1900MHz mobile phone  
**BRAND NAME** : UMX  
**MODEL NAME** : U680  
**FCC ID** : P46-U680  
**STANDARD** : FCC Part 15 Subpart C §15.247  
**CLASSIFICATION** : (DSS) Spread Spectrum Transmitter

The product was received on Dec. 11, 2012 and completely tested on Dec. 31, 2012. We, SPORTON INTERNATIONAL (KUNSHAN) INC., would like to declare that the tested sample has been evaluated in accordance with the procedures and shown the compliance with the applicable technical standards.

The test results in this report apply exclusively to the tested model / sample. Without written approval of SPORTON INTERNATIONAL (KUNSHAN) INC., the test report shall not be reproduced except in full.

Reviewed by:

Jones Tsai / Manager



**SPORTON INTERNATIONAL (KUNSHAN) INC.**  
**No. 3-2, PingXiang Road, Kunshan, Jiangsu Province, P.R.C.**



# TABLE OF CONTENTS

**REVISION HISTORY..... 3**

**SUMMARY OF TEST RESULT ..... 4**

**1 GENERAL DESCRIPTION..... 5**

    1.1 Applicant..... 5

    1.2 Manufacturer..... 5

    1.3 Feature of Equipment Under Test..... 5

    1.4 Product Specification of Equipment Under Test..... 5

    1.5 Testing Site..... 6

    1.6 Applied Standards ..... 6

**2 TEST CONFIGURATION OF EQUIPMENT UNDER TEST..... 7**

    2.1 Descriptions of Test Mode..... 7

    2.2 Test Mode..... 8

    2.3 Connection Diagram of Test System..... 9

    2.4 Support Unit used in test configuration and system ..... 10

    2.5 Description of RF Function Operation Test Setup..... 10

    2.6 Measurement Results Explanation Example..... 11

**3 TEST RESULT ..... 13**

    3.1 Number of Channel Measurement ..... 13

    3.2 Hopping Channel Separation Measurement ..... 15

    3.3 Dwell Time Measurement..... 22

    3.4 20dB and 99% Bandwidth Measurement ..... 24

    3.5 Peak Output Power Measurement ..... 37

    3.6 Conducted Band Edges Measurement ..... 40

    3.7 Conducted Spurious Emission Measurement ..... 47

    3.8 Radiated Band Edges and Spurious Emission Measurement ..... 51

    3.9 AC Conducted Emission Measurement..... 63

    3.10 Antenna Requirements..... 67

**4 LIST OF MEASURING EQUIPMENT..... 68**

**5 UNCERTAINTY OF EVALUATION..... 69**

**APPENDIX A. PHOTOGRAPHS OF EUT**

**APPENDIX B. SETUP PHOTOGRAPHS**





## SUMMARY OF TEST RESULT

Report Section	FCC Rule	IC Rule	Description	Limit	Result	Remark
3.1	15.247(a)(1)	A8.4(2)	Number of Channels	≥ 15Chs	Pass	-
3.2	15.247(a)(1)	A8.1(b)	Hopping Channel Separation	≥ 2/3 of 20dB BW	Pass	-
3.3	15.247(a)(1)	A8.1(d)	Dwell Time of Each Channel	≤ 0.4sec in 31.6sec period	Pass	-
3.4	15.247(a)(1)	A8.1(a)	20dB Bandwidth	NA	Pass	-
3.4	-	Gen 4.6.1	99% Bandwidth	-	Pass	-
3.5	15.247(b)(1)	A8.1(b)	Peak Output Power	≤ 1 w for 1Mbps ≤ 125 Mw for 2, 3Mbps	Pass	-
3.6	15.247(d)	A8.5	Conducted Band Edges	≤ 20dBc	Pass	-
3.7	15.247(d)	A8.5	Conducted Spurious Emission	≤ 20dBc	Pass	-
3.8	15.247(d)	A8.5	Radiated Band Edges and Radiated Spurious Emission	15.209(a) & 15.247(d)	Pass	Under limit 8.08 dB at 2483.500 MHz
3.9	15.207	Gen 7.2.4	AC Conducted Emission	15.207(a)	Pass	Under limit 7.22 dB at 1.220 MHz
3.10	15.203 & 15.247(b)	A8.4	Antenna Requirement	N/A	Pass	-



# 1 General Description

## 1.1 Applicant

**Unimax Communications**

18201 McDermott St. West Suite E, Irvine, CA 92614

## 1.2 Manufacturer

**Unimax Communications**

18201 McDermott St. West Suite E, Irvine, CA 92614

## 1.3 Feature of Equipment Under Test

Product Feature	
Equipment	CDMA EVDO REV A 800/1900MHz mobile phone
Brand Name	UMX
Model Name	U680
FCC ID	P46-U680
EUT supports Radios application	CDMA/EV-DO/WLAN 11bgn/Bluetooth3.0 EDR
HW Version	G3616_V1.1
SW Version	U680_05.03
EUT Stage	Identical Prototype

Remark:

1. The above EUT's information was declared by manufacturer. Please refer to the specifications or user's manual for more detailed description.
2. There are two different types of EUT that only with different logo in the front. The others are the same including circuit design, PCB board, structure and all components. It is special to declare.

## 1.4 Product Specification of Equipment Under Test

Product Specification subjective to this standard	
Tx/Rx Frequency Range	2402 MHz ~ 2480 MHz
Number of Channels	79
Carrier Frequency of Each Channel	2402+n*1 MHz; n=0~78
Maximum Output Power to Antenna	Bluetooth BDR (1Mbps) : 9.05 dBm (0.0080 W) Bluetooth EDR (2Mbps) : 9.79 dBm (0.0095 W) Bluetooth EDR (3Mbps) : 10.23 dBm (0.0105 W)
99% Occupied Bandwidth	Bluetooth BDR (1Mbps) : 0.8760MHz Bluetooth EDR (2Mbps) : 1.1700MHz Bluetooth EDR (3Mbps) : 1.1640MHz
Antenna Type	PIFA Antenna type with gain -1.50 dBi
Type of Modulation	Bluetooth 3.0 BDR (1Mbps) : GFSK Bluetooth 3.0 EDR (2Mbps) : $\pi/4$ -DQPSK Bluetooth 3.0 EDR (3Mbps) : 8-DPSK



### 1.5 Testing Site

<b>Test Site</b>	SPORTON INTERNATIONAL (KUNSHAN) INC.			
<b>Test Site Location</b>	No. 3-2, PingXiang Road, Kunshan, Jiangsu Province, P.R.C. TEL: +86-0512-5790-0158 FAX: +86-0512-5790-0958			
<b>Test Site No.</b>	<b>Sporton Site No.</b>			<b>FCC/IC Registration No.</b>
	TH01-KS	CO01-KS	03CH01-KS	149928/4086E-1

### 1.6 Applied Standards

According to the specifications of the manufacturer, the EUT must comply with the requirements of the following standards:

- ♦ FCC Part 15 Subpart C §15.247
- ♦ FCC Public Notice DA 00-705
- ♦ ANSI C63.4-2003 and ANSI C63.10-2009
- ♦ IC RSS-210 Issue 8
- ♦ IC RSS-Gen Issue 3
- ♦ NOTICE 2012-DRS0126

**Remark:**

1. All test items were verified and recorded according to the standards and without any deviation during the test.
2. This EUT has also been tested and complied with the requirements of FCC Part 15, Subpart B, recorded in a separate test report.
3. Per the section 2.2.3 of Notice of 2012-DRS0126, “ Receivers Excluded from Industry Canada Requirements”, only radio communication receivers operating in stand-alone mode within the band 30-960 MHz and scanner receivers are subject to Industry Canada requirements.

## 2 Test Configuration of Equipment Under Test

### 2.1 Descriptions of Test Mode

Preliminary tests were performed in different data rate and recorded the RF output power in the following table:

Channel	Frequency	Bluetooth RF Output Power		
		Data Rate / Modulation		
		GFSK	$\pi/4$ -DQPSK	8-DPSK
		1Mbps	2Mbps	3Mbps
Ch00	2402MHz	7.85 dBm	8.54 dBm	8.97 dBm
Ch39	2441MHz	8.47 dBm	9.19 dBm	9.56 dBm
Ch78	2480MHz	9.05 dBm	9.79 dBm	<b>10.23 dBm</b>

**Remark:**

1. All the test data for each data rate were verified, but only the worst case was reported.
  2. The data rate was set in 3Mbps for all the test items due to the highest RF output power.
- a. The EUT has been associated with peripherals pursuant to ANSI C63.4-2003 and ANSI C63.10-2009 and configuration operated in a manner tended to maximize its emission characteristics in a typical application. Frequency range investigated: conduction (150 KHz to 30 MHz), radiation (9 KHz to the 10th harmonic of the highest fundamental frequency or to 40 GHz, whichever is lower). Pre-scanned tests, X, Y, Z in three orthogonal panels, and different data rates were conducted to determine the final configuration (Y plane as worst plane) from all possible combinations, and the worst mode of radiated spurious emissions is Bluetooth 3Mbps mode, and recorded in this report.
  - b. AC power line Conducted Emission was tested under maximum output power.

## 2.2 Test Mode

The following summary table is showing all test modes to demonstrate in compliance with the standard.

Summary table of Test Cases			
Test Item	Data Rate / Modulation		
	Bluetooth BDR 1Mbps GFSK	Bluetooth EDR 2Mbps $\pi/4$ -DQPSK	Bluetooth EDR 3Mbps 8-DPSK
Conducted Test Cases	Mode 1: CH00_2402 MHz	Mode 4: CH00_2402 MHz	Mode 7: CH00_2402 MHz
	Mode 2: CH39_2441 MHz	Mode 5: CH39_2441 MHz	Mode 8: CH39_2441 MHz
	Mode 3: CH78_2480 MHz	Mode 6: CH78_2480 MHz	Mode 9: CH78_2480 MHz
Radiated Test Cases	Bluetooth EDR 3Mbps 8-DPSK		
	Mode 1: CH00_2402 MHz		
	Mode 2: CH39_2441 MHz		
	Mode 3: CH78_2480 MHz		
AC Conducted Emission	Mode 1 :CDMA2000 BC0 Idle + WLAN Link + Bluetooth Link + USB Cable (Charging from Adapter) + Earphone		
<p><b>Remark:</b> For radiated test cases, the worst mode data rate 3Mbps was reported only, because this data rate has the highest RF output power at preliminary tests, and the conducted spurious emissions and conducted band edge measurement for each data rate are no worse than 3Mbps, and no other significantly frequencies found in conducted spurious emission.</p>			



## 2.3 Connection Diagram of Test System

<Bluetooth Tx Mode>

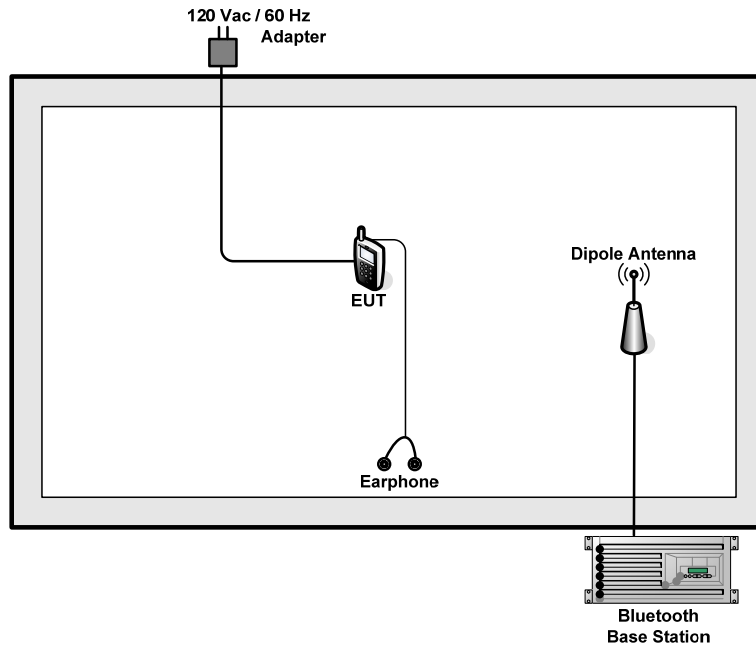

<AC Conducted Emission Mode>

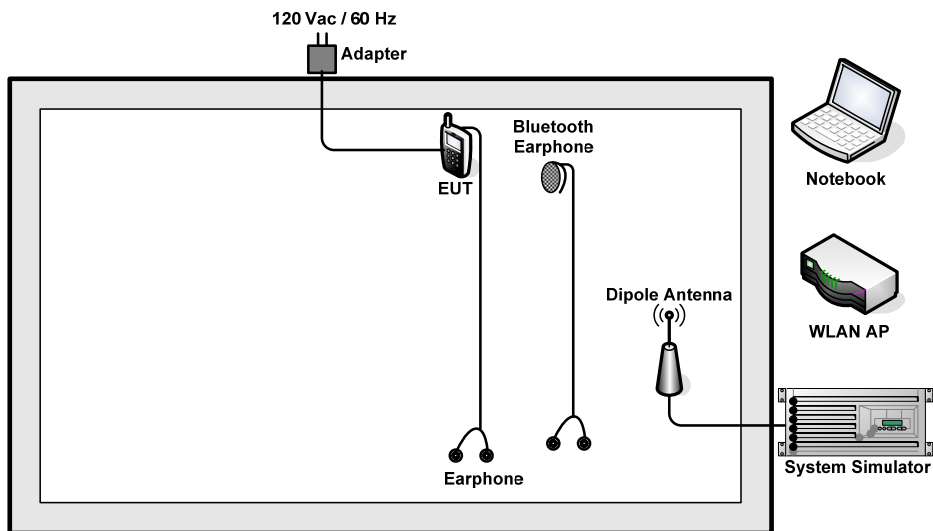

## 2.4 Support Unit used in test configuration and system

Item	Equipment	Trade Name	Model Name	FCC ID	Data Cable	Power Cord
1.	System Simulator	R&S	CMU 200	N/A	N/A	Unshielded, 1.8 m
2.	Bluetooth Base Station	R&S	CBT	FCC DoC	N/A	Unshielded, 1.8 m
3.	DC Power Supply	GWINSTEK	GPS-3030D	N/A	N/A	Unshielded, 1.8 m
4.	WLAN AP	D-Link	DIR-855	KA2DIR855A2	N/A	Unshielded, 1.8 m
5.	Notebook	DELL	P08S	QDS-BRCM1030	N/A	AC I/P: Unshielded, 0.9 m DC O/P: Shielded, 1.8 m
6.	Bluetooth Earphone	Nokia	BH-106	QTLBH-106	N/A	N/A

## 2.5 Description of RF Function Operation Test Setup

For Bluetooth function, programmed RF utility, “ADB” installed in the EUT make the EUT provides functions like channel selection and power level for continuous transmitting and receiving signals.

## 2.6 Measurement Results Explanation Example

### For conducted test items:

The offset level is set in the spectrum analyzer to compensate the RF cable loss and 10dB attenuator between EUT conducted output port and spectrum analyzer. With the offset compensation, the spectrum analyzer reading level is exactly the EUT RF output level.

The spectrum analyzer offset is derived from RF cable loss and 10dB attenuator factor.

*Offset = RF cable loss + attenuator factor.*

Following table shows an offset computation example with cable loss 5.6 dB.

Example :

$$\begin{aligned} \text{Offset(dB)} &= \text{RF cable loss(dB)} + \text{attenuator factor(dB)} \\ &= 5.6 + 10 = 15.6 \text{ (dB)} \end{aligned}$$

### For radiated band edges and spurious emission test :

Per part 15.35(c), the EUT Bluetooth average emission level could be determined by the peak emission level applying duty cycle correction factor, to represent averaging over the whole pulse train.

The average level is derived from the peak level corrected with "Duty cycle correction factor".

$$\text{Average Emission Level(dBuV/m)} = \text{Peak Emission Level(dBuV/m)} + \text{Duty cycle correction factor(dB)}$$

$$\text{Duty cycle correction factor(dB)} = 20 * \log(\text{Duty cycle}).$$

$$\text{Duty cycle} = \text{On time} / 100 \text{ milliseconds}$$

$$\text{On time} = \text{dwell time} * \text{hopping number in } 100 \text{ ms}$$

For example : bluetooth with dwell time 2.9ms and 2 hops in 100 ms, then

$$\text{Duty cycle correction factor(dB)} = 20 * \log( (2.9 * 2) / 100 ) = -24.73 \text{ dB}$$

Following shows an average computation example with duty cycle correction factor = -24.73dB, and the peak emission level is 45.61 dBuV/m.



Example :

$$\begin{aligned} \text{Average Emission Level(dBuV/m)} &= \text{Peak Emission Level(dBuV/m)} + \text{duty cycle correction factor(dB)} \\ &= 45.61 + ( -24.73 ) = 20.88 \text{ (dBuV/m)} \end{aligned}$$





Number of Hopping Channel Plot on Channel 00 - 78

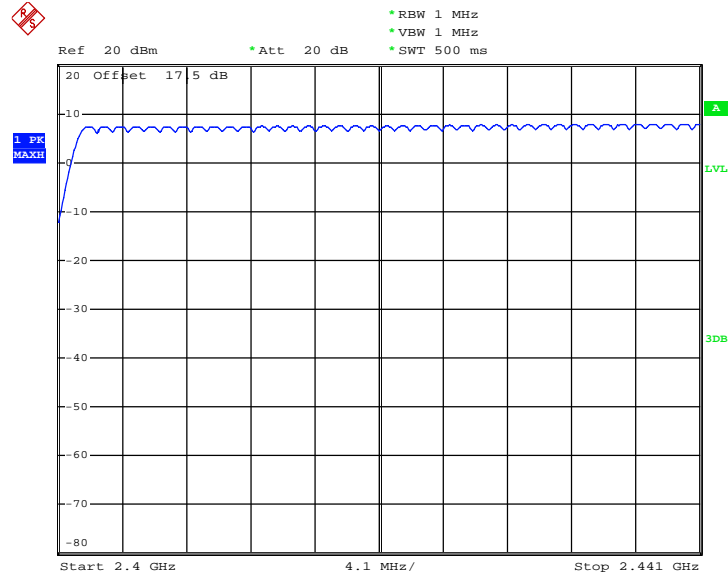

Date: 14.DEC.2012 16:39:23

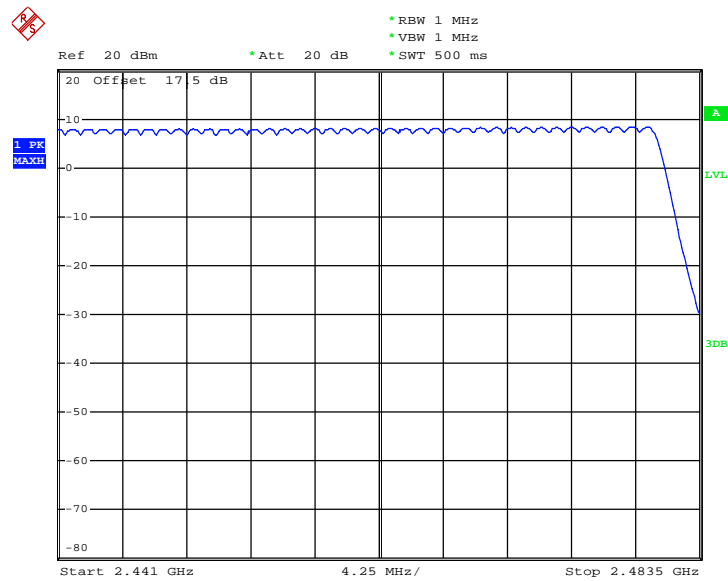

Date: 14.DEC.2012 16:44:32

## 3.2 Hopping Channel Separation Measurement

### 3.2.1 Limit of Hopping Channel Separation

Frequency hopping systems operating in the 2400-2483.5 MHz band may have hopping channel carrier frequencies that are separated by 25 KHz or two-thirds of the 20 dB bandwidth of the hopping channel, whichever is greater.

### 3.2.2 Measuring Instruments

See list of measuring instruments of this test report.

### 3.2.3 Test Procedures

1. The testing follows FCC Public Notice DA 00-705 Measurement Guidelines.
2. The RF output of EUT was connected to the spectrum analyzer by RF cable and attenuator. The path loss was compensated to the results for each measurement.
3. Set to the maximum power setting and enable the EUT transmit continuously.
4. Enable the EUT hopping function.
5. Use the following spectrum analyzer settings:  
Span = wide enough to capture the peaks of two adjacent channels;  $RBW \geq 1\%$  of the span;  
 $VBW \geq RBW$ ; Sweep = auto; Detector function = peak; Trace = max hold.
6. Measure and record the results in the test report.

### 3.2.4 Test Setup

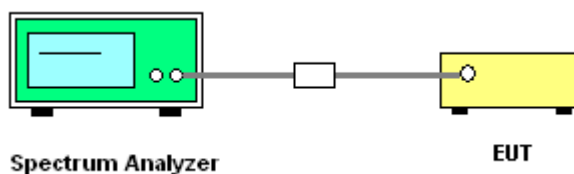



3.2.5 Test Result of Hopping Channel Separation

Test Mode :	1Mbps	Temperature :	20~21°C
Test Engineer :	Zhi Lu	Relative Humidity :	40~41%

Channel	Frequency (MHz)	Frequency Separation (MHz)	(2/3 of 20dB BW) Limits (MHz)	Pass/Fail
00	2402	1.002	0.6373	Pass
39	2441	1.008	0.6240	Pass
78	2480	1.002	0.6027	Pass

Channel Separation Plot on Channel 00 - 01

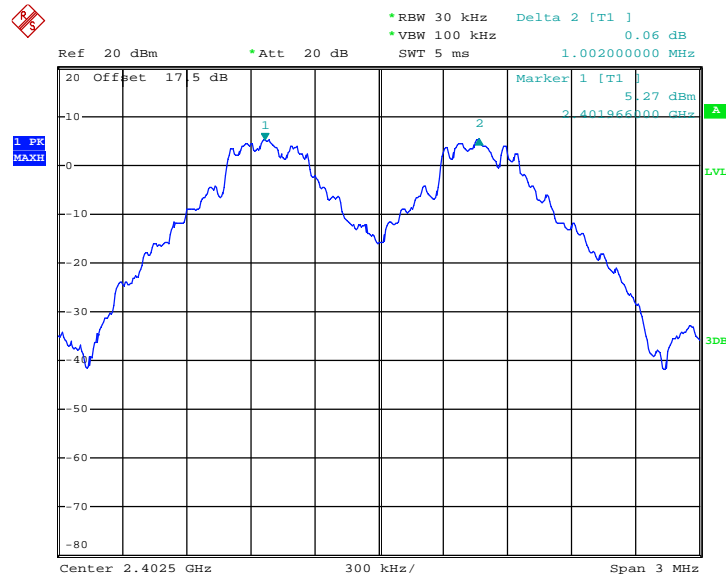

Date: 14.DEC.2012 16:00:09





### Channel Separation Plot on Channel 39 - 40

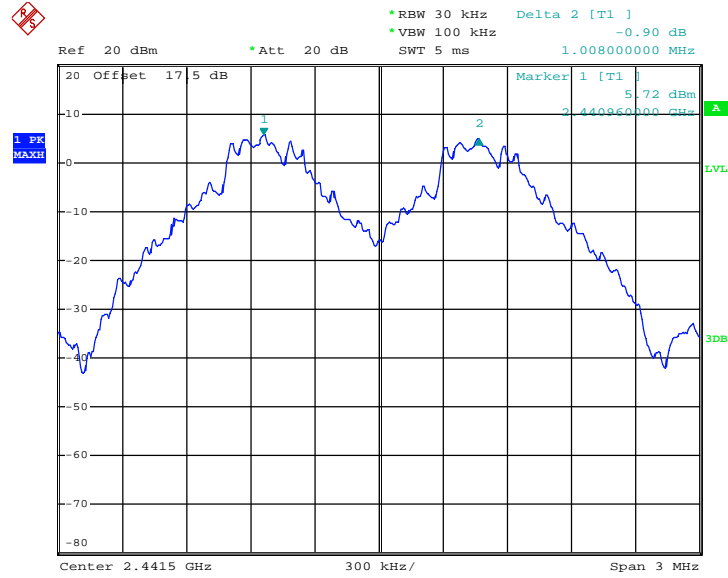

Date: 14.DEC.2012 16:01:18

### Channel Separation Plot on Channel 77 - 78

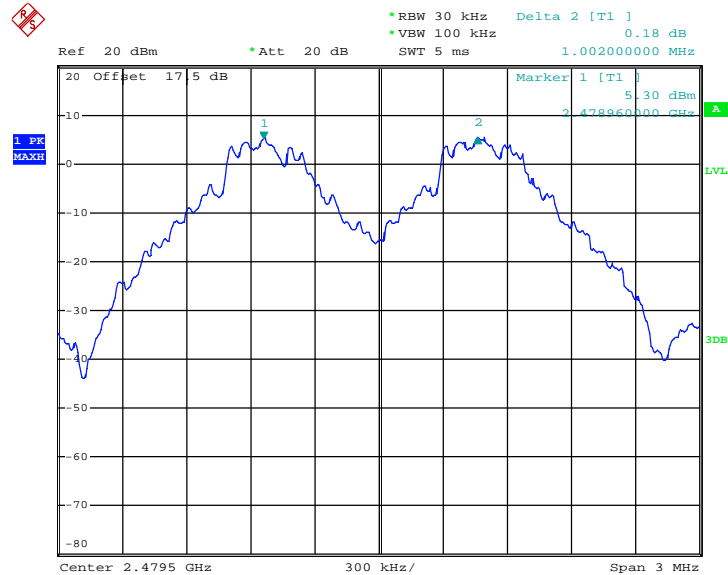

Date: 14.DEC.2012 16:02:14



Test Mode :	2Mbps	Temperature :	20~21°C
Test Engineer :	Zhi Lu	Relative Humidity :	40~41%

Channel	Frequency (MHz)	Frequency Separation (MHz)	(2/3 of 20dB BW) Limits (MHz)	Pass/Fail
00	2402	1.002	0.8347	Pass
39	2441	1.002	0.8560	Pass
78	2480	1.002	0.8320	Pass

Channel Separation Plot on Channel 00 - 01

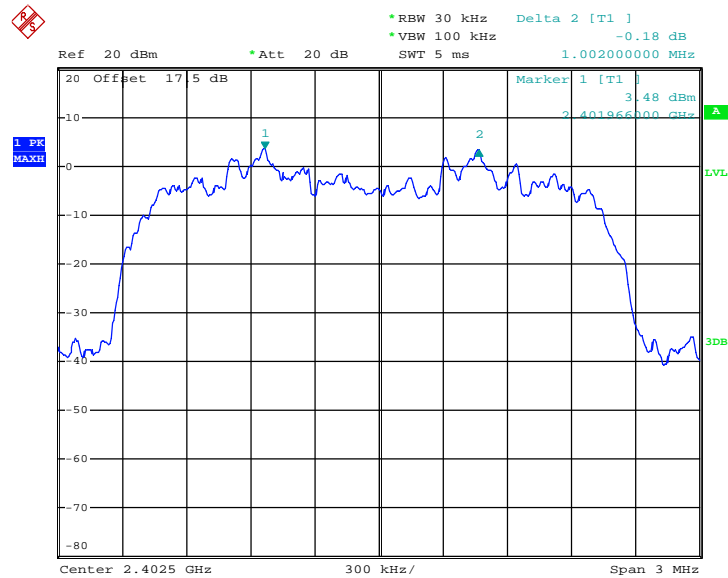

Date: 14.DEC.2012 16:04:39



### Channel Separation Plot on Channel 39 - 40

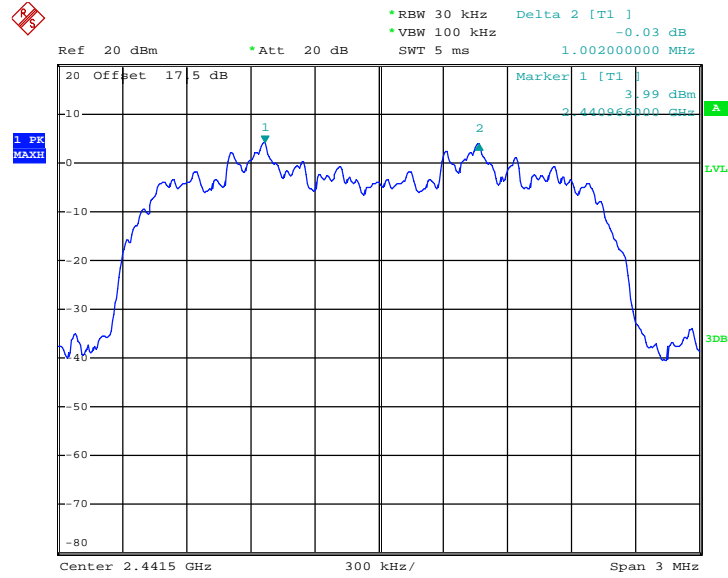

Date: 14.DEC.2012 16:03:39

### Channel Separation Plot on Channel 77 - 78

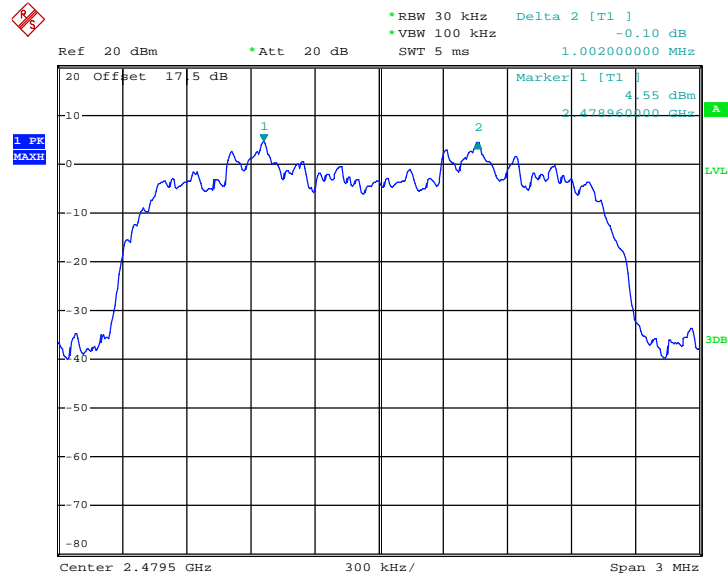

Date: 14.DEC.2012 16:02:59



Test Mode :	3Mbps	Temperature :	20~21°C
Test Engineer :	Zhi Lu	Relative Humidity :	40~41%

Channel	Frequency (MHz)	Frequency Separation (MHz)	(2/3 of 20dB BW) Limits (MHz)	Pass/Fail
00	2402	1.008	0.8267	Pass
39	2441	1.002	0.8373	Pass
78	2480	1.002	0.8320	Pass

Channel Separation Plot on Channel 00 - 01

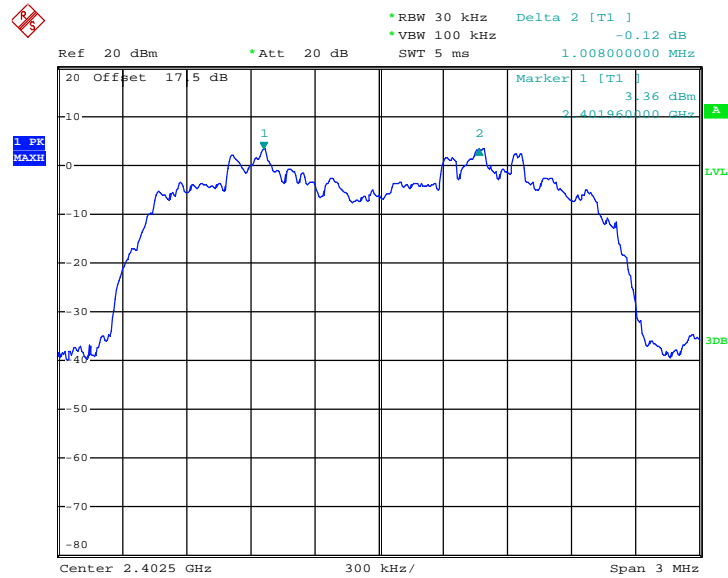

Date: 14.DEC.2012 16:05:18



Channel Separation Plot on Channel 39 - 40

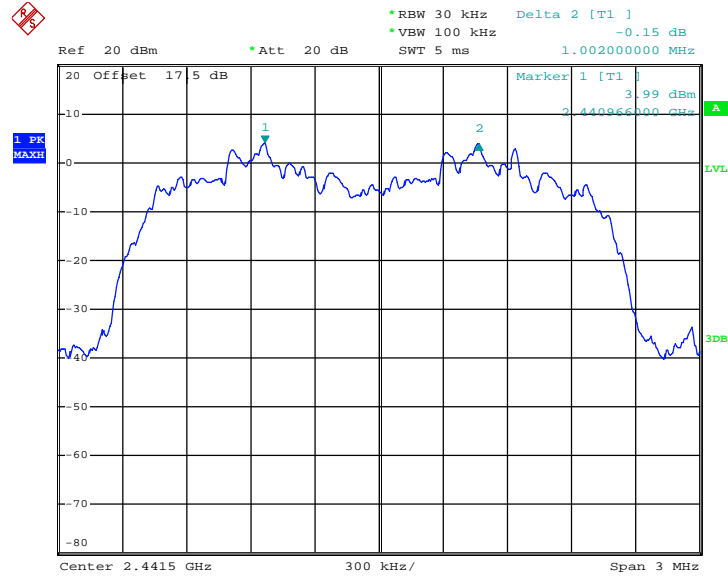

Date: 14.DEC.2012 16:05:51

Channel Separation Plot on Channel 77 - 78

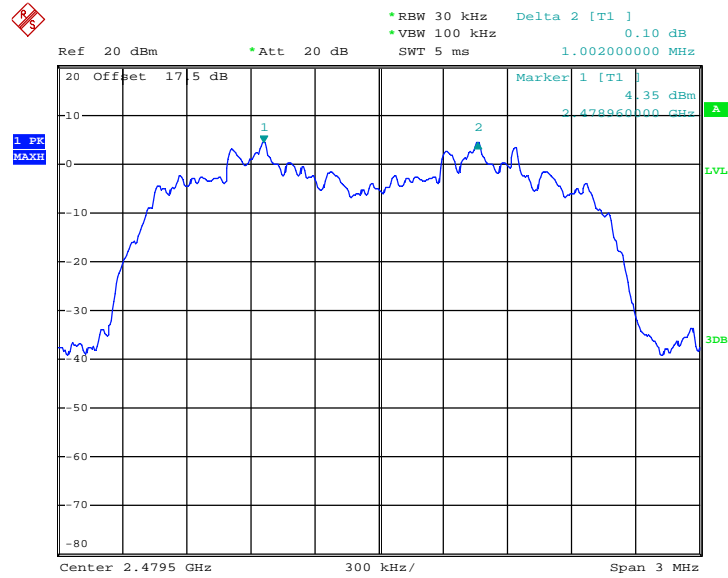

Date: 14.DEC.2012 16:06:46



**Remark:**

1. In normal mode, hopping rate is 1600hops/s with 6 slots in 79 hopping channels.  
 With channel hopping rate (1600 / 6 / 79) in Occupancy Time Limit (0.4 x 79) (s),  
 Hops Over Occupancy Time comes to (1600 / 6 / 79) x (0.4 x 79) = 106.67 hops.
  
2. In AFH mode, hopping rate is 800hops/s with 6 slots in 20 hopping channels.  
 With channel hopping rate (800 / 6 / 20) in Occupancy Time Limit (0.4 x 20) (s),  
 Hops Over Occupancy Time comes to (800 / 6 / 20) x (0.4 x 20) = 53.34 hops.
  
3. Dwell Time(s) = Hops Over Occupancy Time (hops) x Package Transfer Time

**Package Transfer Time Plot**

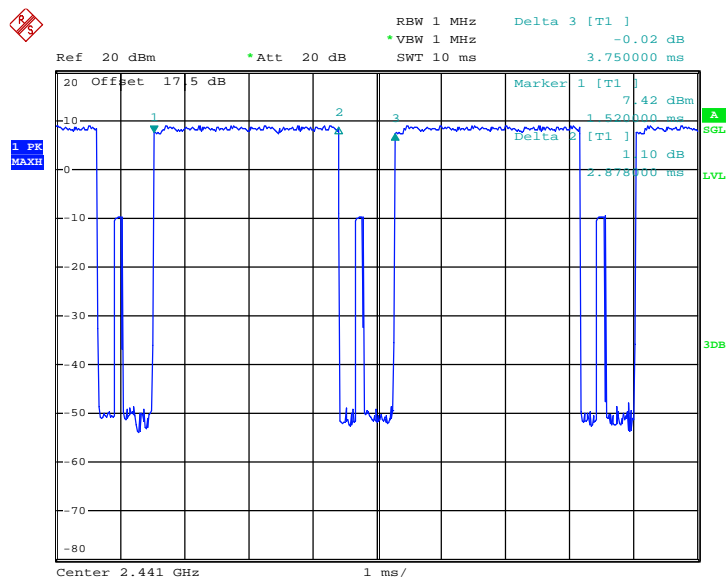

Date: 13.DEC.2012 10:39:54

### 3.4 20dB and 99% Bandwidth Measurement

#### 3.4.1 Limit of 20dB and 99% Bandwidth

Reporting only

#### 3.4.2 Measuring Instruments

See list of measuring instruments of this test report.

#### 3.4.3 Test Procedures

1. The testing follows FCC Public Notice DA 00-705 Measurement Guidelines.
2. The RF output of EUT was connected to the spectrum analyzer by RF cable and attenuator. The path loss was compensated to the results for each measurement.
3. Set to the maximum power setting and enable the EUT transmit continuously.
4. Use the following spectrum analyzer settings for 20dB Bandwidth measurement.  
Span = approximately 2 to 3 times the 20 dB bandwidth, centered on a hopping channel;  
RBW  $\geq$  1% of the 20 dB bandwidth; VBW  $\geq$  RBW; Sweep = auto; Detector function = peak;  
Trace = max hold.
5. Use the following spectrum analyzer settings for 99 % Bandwidth measurement.  
For 99% Bandwidth measurement, the RBW=30kHz, and VBW = 100 kHz. Sweep = auto ;  
Detector function = sample. Trace = max hold.
6. Measure and record the results in the test report.

#### 3.4.4 Test Setup

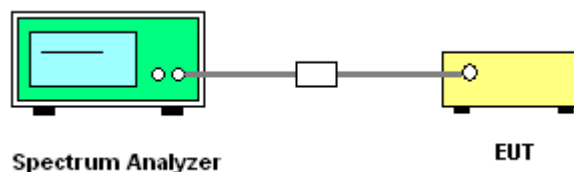



3.4.5 Test Result of 20dB Bandwidth

Test Mode :	1Mbps	Temperature :	20~21°C
Test Engineer :	Zhi Lu	Relative Humidity :	40~41%

Channel	Frequency (MHz)	20dB Bandwidth (MHz)
00	2402	0.956
39	2441	0.936
78	2480	0.904

20 dB Bandwidth Plot on Channel 00

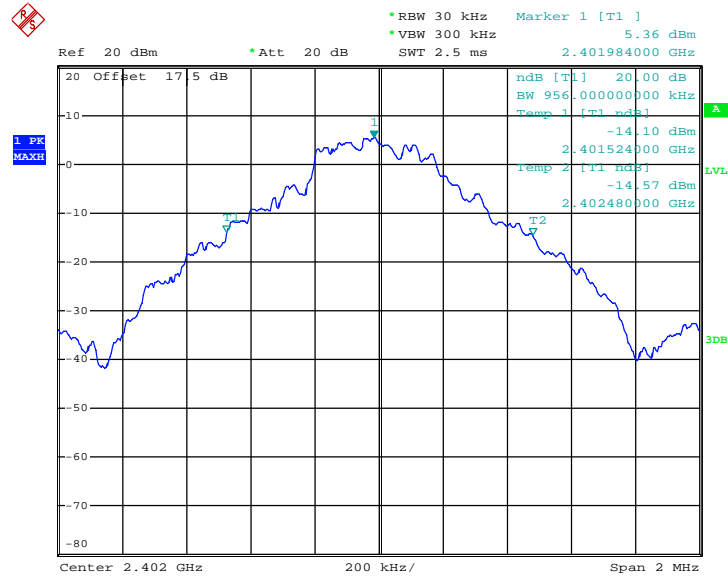

Date: 14.DEC.2012 15:48:05



20 dB Bandwidth Plot on Channel 39

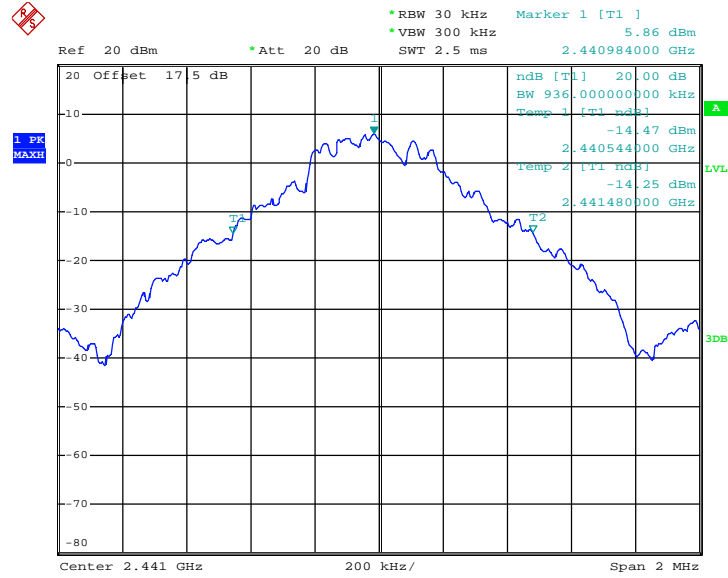

Date: 14.DEC.2012 15:48:31

20 dB Bandwidth Plot on Channel 78

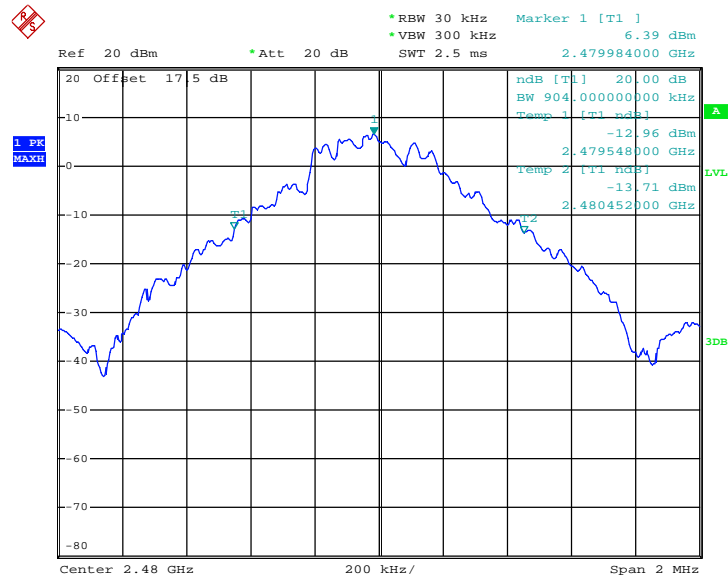

Date: 14.DEC.2012 15:48:51



Test Mode :	2Mbps	Temperature :	20~21°C
Test Engineer :	Zhi Lu	Relative Humidity :	40~41%

Channel	Frequency (MHz)	20dB Bandwidth (MHz)
00	2402	1.252
39	2441	1.284
78	2480	1.248

20 dB Bandwidth Plot on Channel 00

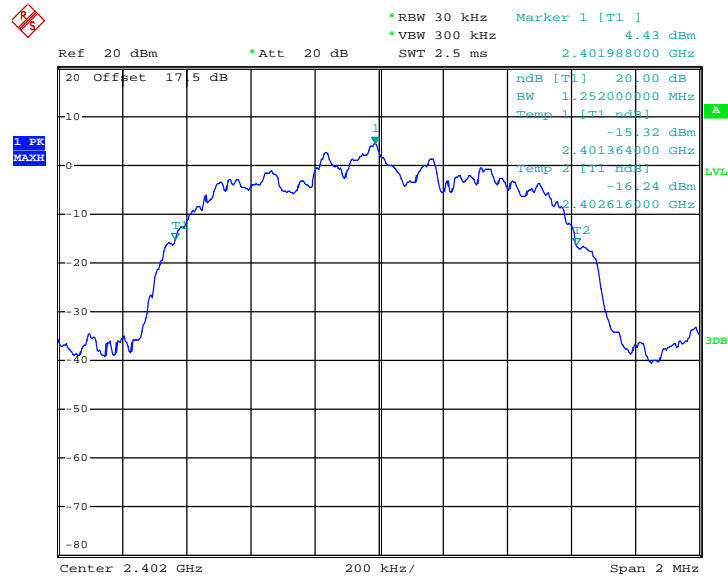

Date: 14.DEC.2012 15:50:22



### 20 dB Bandwidth Plot on Channel 39

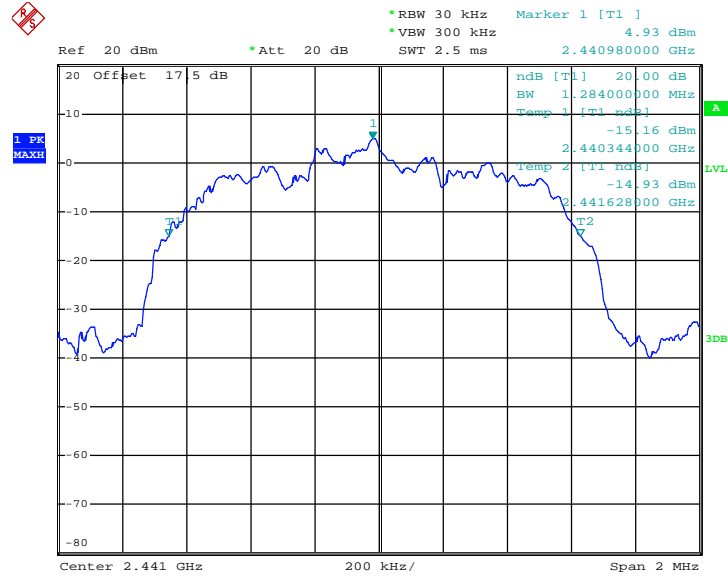

Date: 14.DEC.2012 15:50:01

### 20 dB Bandwidth Plot on Channel 78

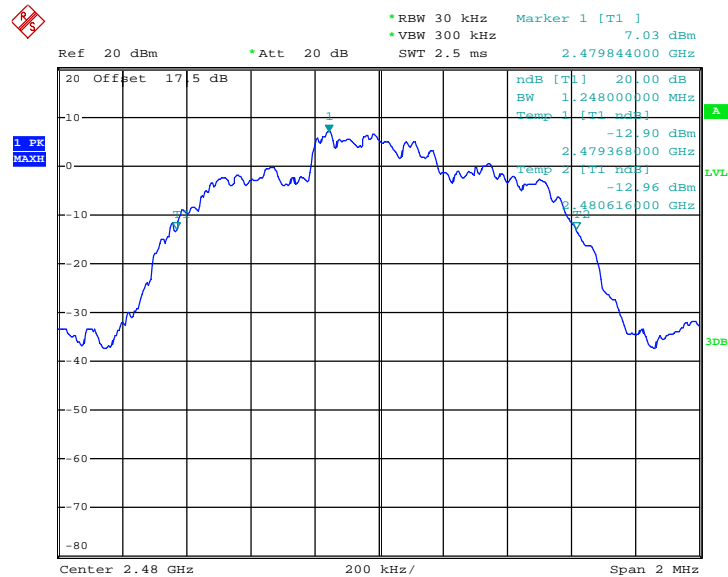

Date: 14.DEC.2012 15:49:34



Test Mode :	3Mbps	Temperature :	20~21°C
Test Engineer :	Zhi Lu	Relative Humidity :	40~41%

Channel	Frequency (MHz)	20dB Bandwidth (MHz)
00	2402	1.240
39	2441	1.256
78	2480	1.248

20 dB Bandwidth Plot on Channel 00

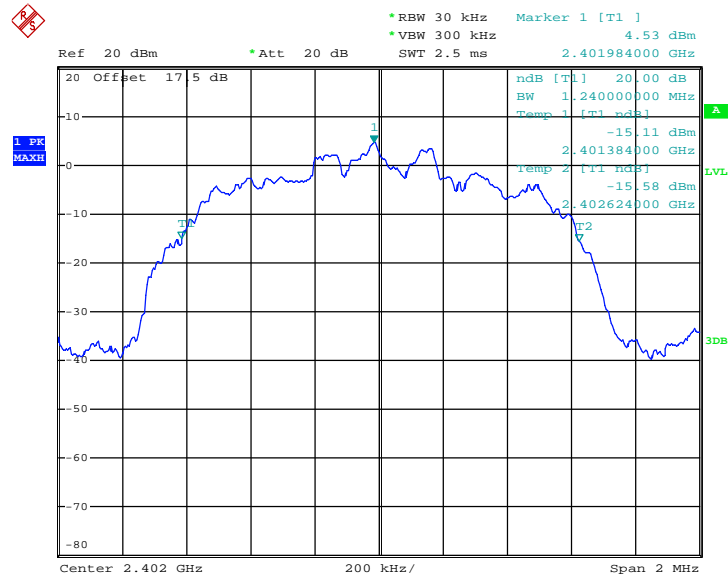

Date: 14.DEC.2012 15:51:15



20 dB Bandwidth Plot on Channel 39

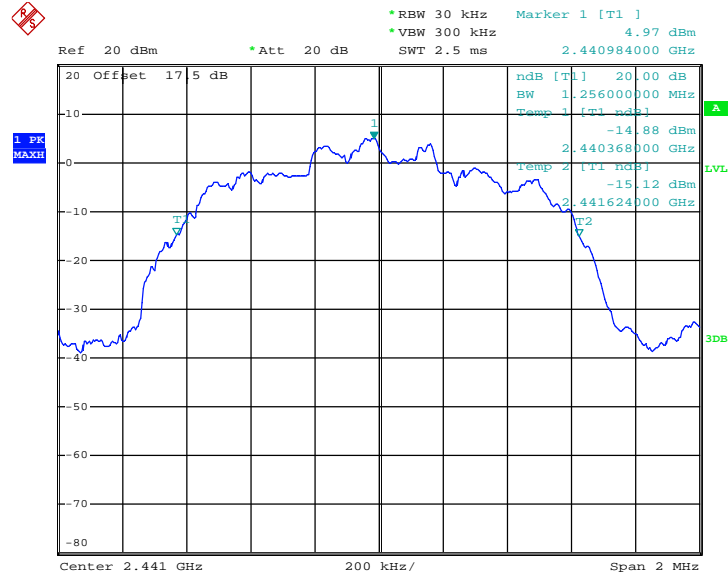

Date: 14.DEC.2012 15:52:03

20 dB Bandwidth Plot on Channel 78

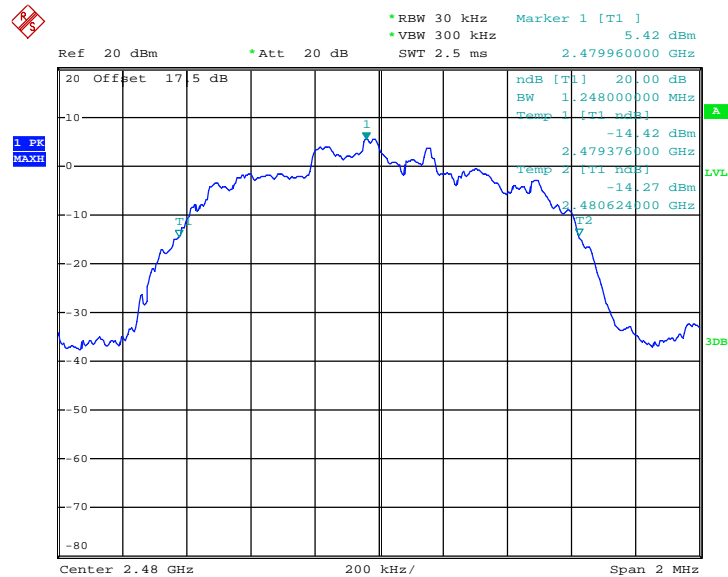

Date: 14.DEC.2012 15:52:40

3.4.6 Test Result of 99% Occupied Bandwidth

Test Mode :	1Mbps	Temperature :	20~21°C
Test Engineer :	Zhi Lu	Relative Humidity :	40~41%

Channel	Frequency (MHz)	99% Occupied Bandwidth (MHz)
00	2402	0.876
39	2441	0.876
78	2480	0.858

99% Bandwidth Plot on Channel 00

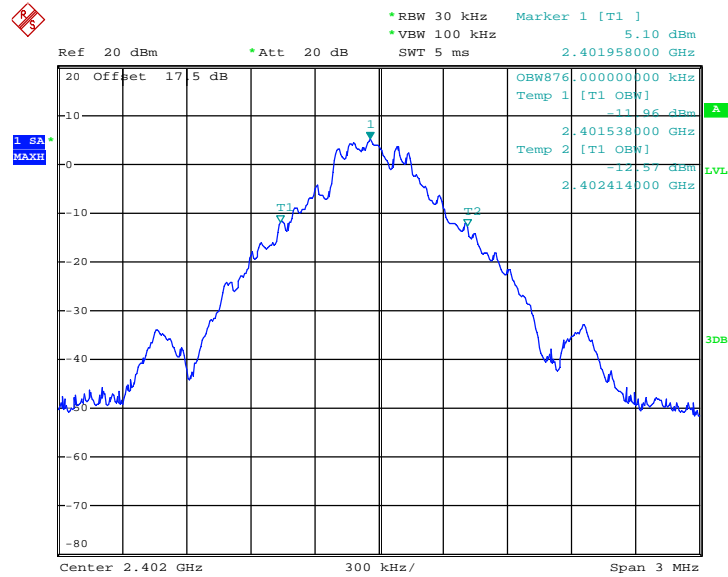

Date: 14.DEC.2012 15:58:41



99% Occupied Bandwidth Plot on Channel 39

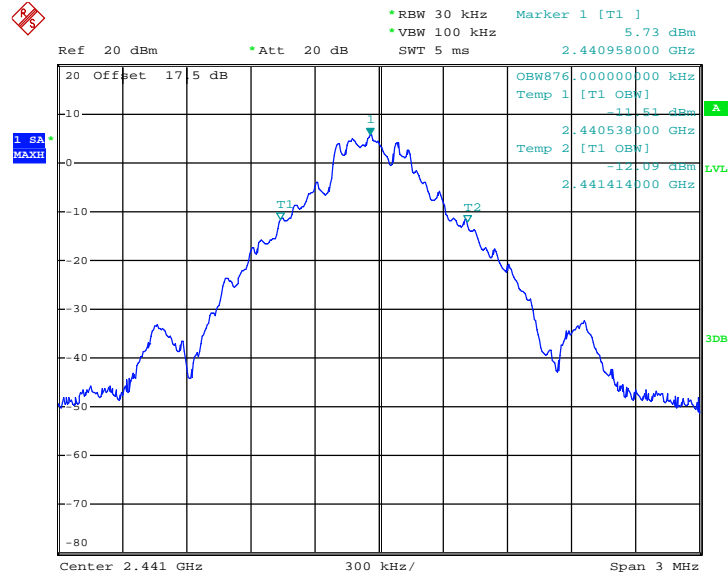

Date: 14.DEC.2012 15:58:19

99% Occupied Bandwidth Plot on Channel 78

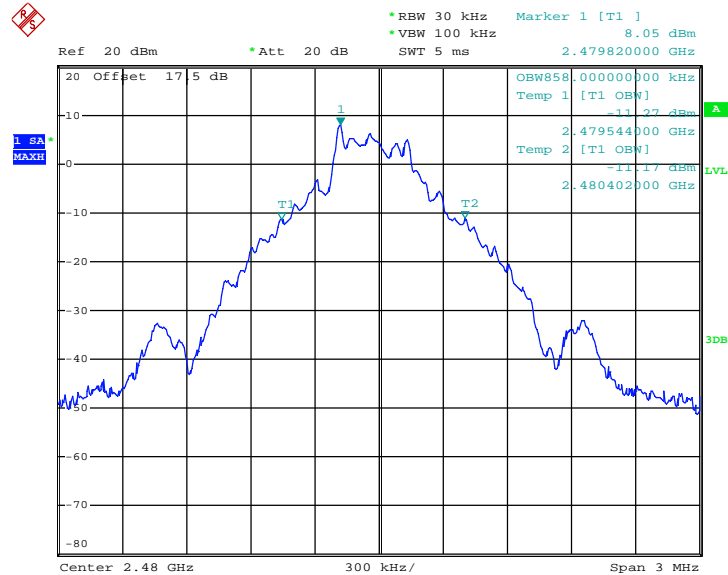

Date: 14.DEC.2012 15:57:48





Test Mode :	2Mbps	Temperature :	20~21°C
Test Engineer :	Zhi Lu	Relative Humidity :	40~41%

Channel	Frequency (MHz)	99% Occupied Bandwidth (MHz)
00	2402	1.164
39	2441	1.170
78	2480	1.170

99% Bandwidth Plot on Channel 00

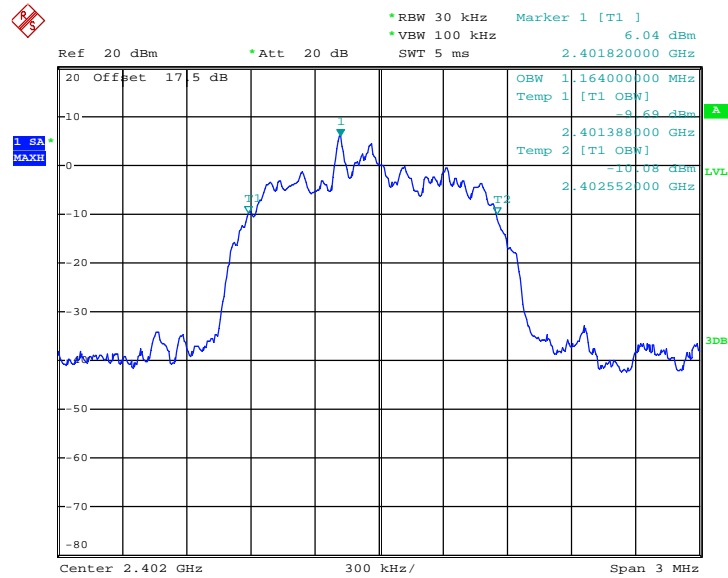

Date: 14.DEC.2012 15:56:32



99% Occupied Bandwidth Plot on Channel 39

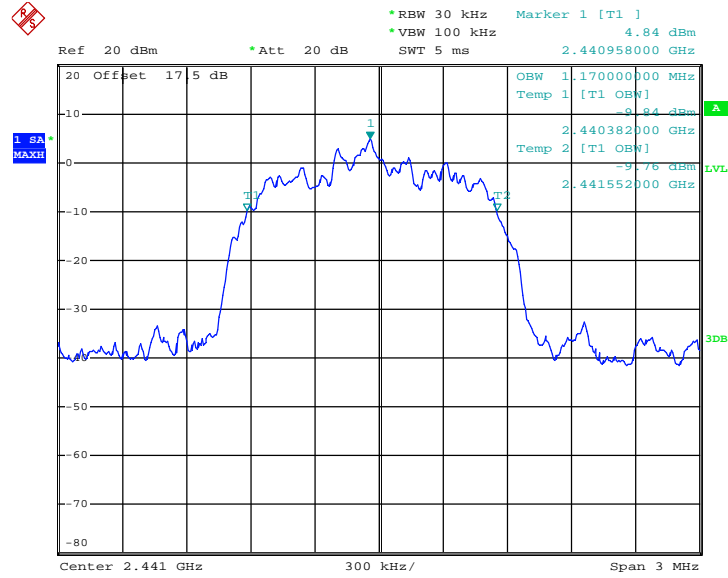

Date: 14.DEC.2012 15:57:02

99% Occupied Bandwidth Plot on Channel 78

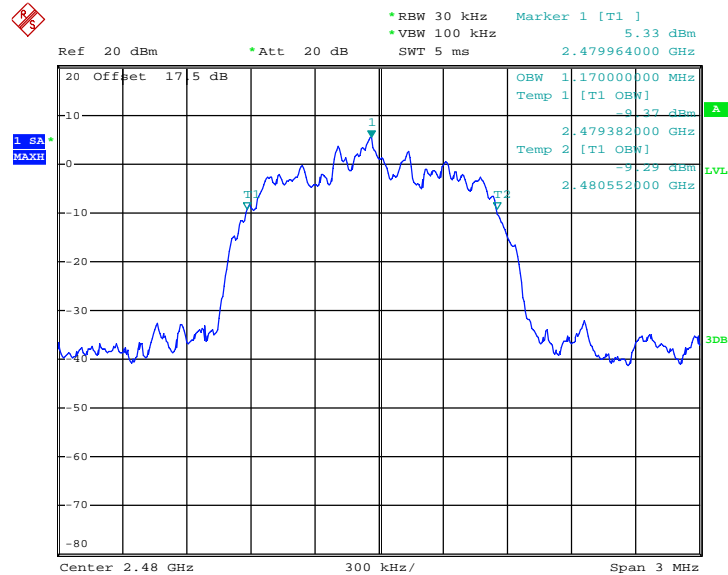

Date: 14.DEC.2012 15:57:25



Test Mode :	3Mbps	Temperature :	20~21°C
Test Engineer :	Zhi Lu	Relative Humidity :	40~41%

Channel	Frequency (MHz)	99% Occupied Bandwidth (MHz)
00	2402	1.152
39	2441	1.164
78	2480	1.146

99% Bandwidth Plot on Channel 00

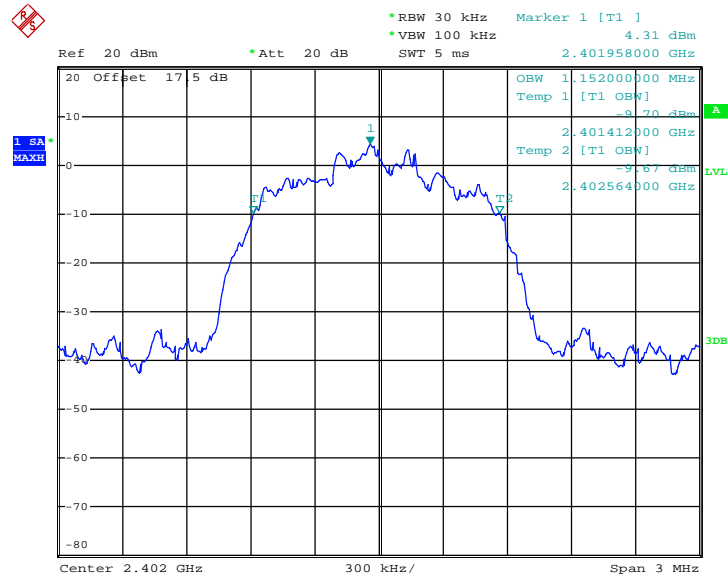

Date: 14.DEC.2012 15:56:10



99% Occupied Bandwidth Plot on Channel 39

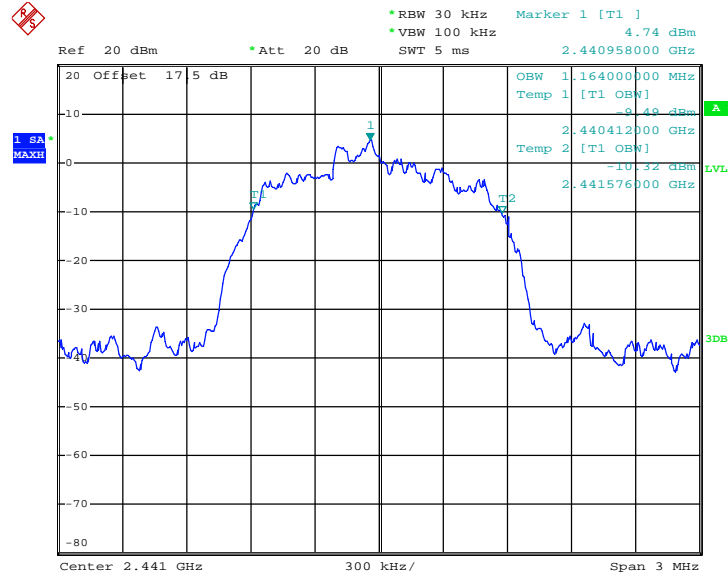

Date: 14.DEC.2012 15:54:12

99% Occupied Bandwidth Plot on Channel 78

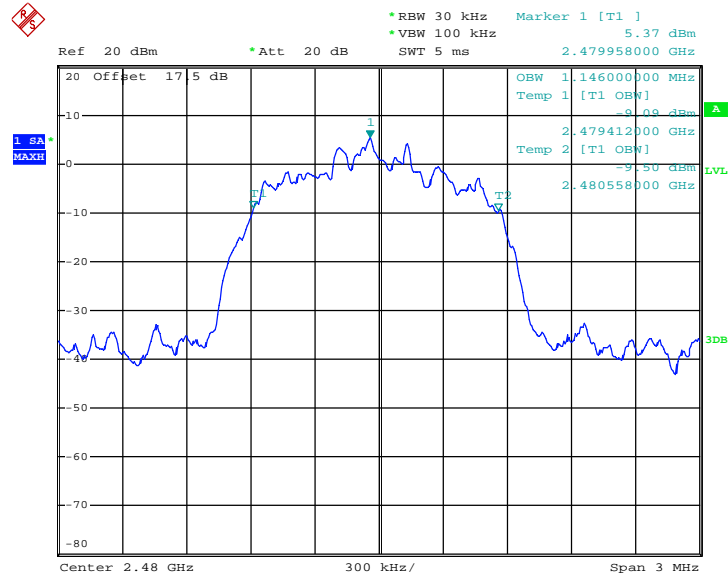

Date: 14.DEC.2012 15:53:47

## 3.5 Peak Output Power Measurement

### 3.5.1 Limit of Peak Output Power

Section 15.247 (b) The maximum peak conducted output power of the intentional radiator shall not exceed the following: (1) For frequency hopping systems operating in the 2400-2483.5 MHz band employing at least 75 non-overlapping hopping channels, and all frequency hopping systems in the 5725-5850 MHz band: 1 watt. For all other frequency hopping systems in the 2400-2483.5 MHz band 0.125 watts. The power limit for 1Mbps is 1watt, and for 2Mbps, and 3Mbps are 0.125 watts.

### 3.5.2 Measuring Instruments

See list of measuring instruments of this test report.

### 3.5.3 Test Procedures

1. The testing follows FCC Public Notice DA 00-705 Measurement Guidelines.
2. The RF output of EUT was connected to the spectrum analyzer by RF cable and attenuator. The path loss was compensated to the results for each measurement.
3. Set to the maximum power setting and enable the EUT transmit continuously.
4. Measure the conducted output power with cable loss and record the results in the test report.
5. Measure and record the results in the test report.

### 3.5.4 Test Setup

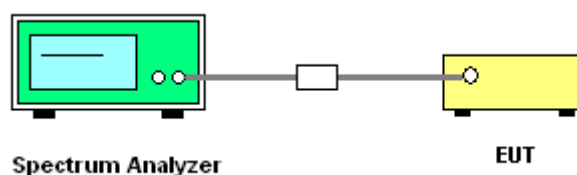



3.5.5 Test Result of Peak Output Power

Test Mode :	3Mbps	Temperature :	20~21°C
Test Engineer :	Zhi Lu	Relative Humidity :	40~41%

Channel	Frequency (MHz)	RF Power (dBm)		
		8-DPSK	Max. Limits (dBm)	Pass/Fail
		3 Mbps		
00	2402	8.97	20.97	Pass
39	2441	9.56	20.97	Pass
78	2480	10.23	20.97	Pass

Peak Output Power Plot on Channel 00

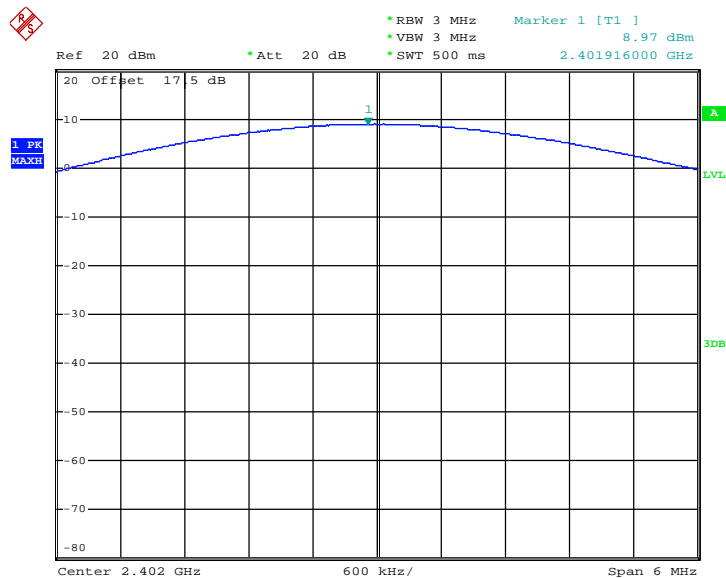

Date: 13.DEC.2012 10:26:18



### Peak Output Power Plot on Channel 39

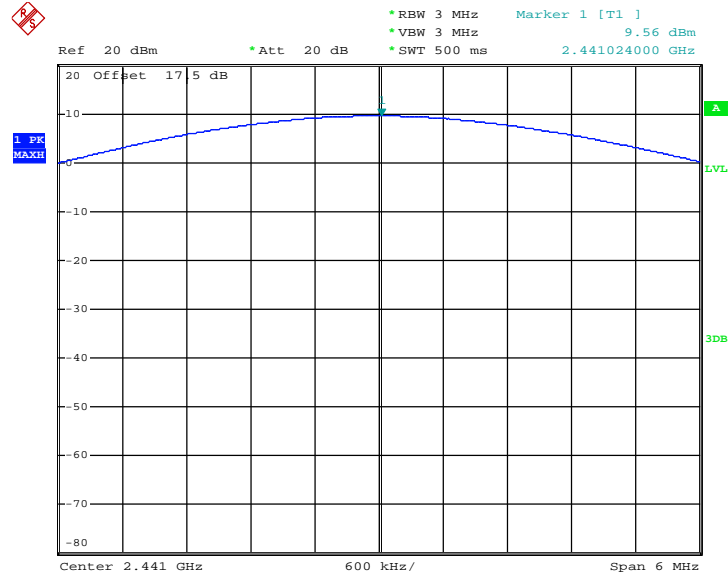

Date: 13.DEC.2012 10:27:50

### Peak Output Power Plot on Channel 78

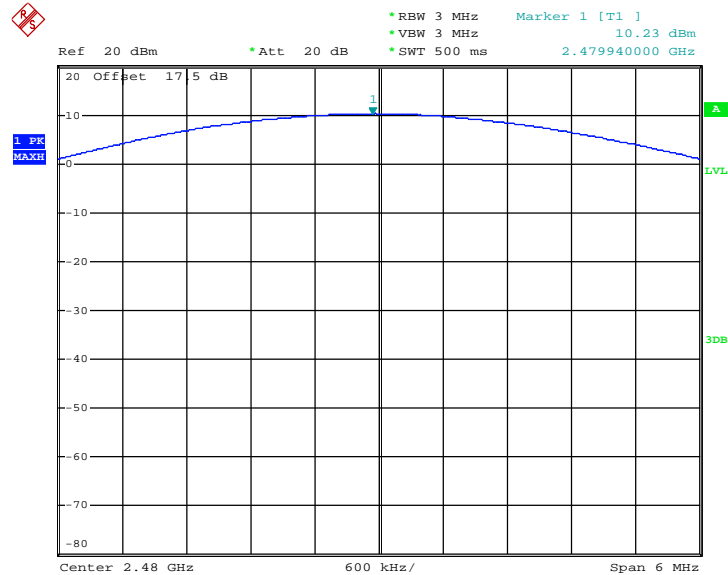

Date: 13.DEC.2012 11:21:46

## 3.6 Conducted Band Edges Measurement

### 3.6.1 Limit of Band Edges

In any 100 KHz bandwidth outside the intentional radiation frequency band, the radio frequency power shall be at least 20 dB below the highest level of the radiated power. In addition, radiated emissions which fall in the restricted bands must also comply with the radiated emission limits.

### 3.6.2 Measuring Instruments

See list of measuring instruments of this test report.

### 3.6.3 Test Procedures

1. The testing follows the guidelines in Band-edge Compliance of RF Conducted Emissions of FCC Public Notice DA 00-705 Measurement Guidelines.
2. Set to the maximum power setting and enable the EUT transmit continuously.
3. Set RBW = 300KHz ( $\geq 1\%$  span=30MHz ), VBW = 300KHz ( $\geq$  RBW). Band edge emissions must be at least 20 dB down from the highest emission level within the authorized band as measured with a 300KHz RBW. The attenuation shall be 30 dB instead of 20 dB when RMS conducted output power procedure is used.
4. Enable hopping function of the EUT and then repeat step 2. and 3.
5. Measure and record the results in the test report.

### 3.6.4 Test Setup

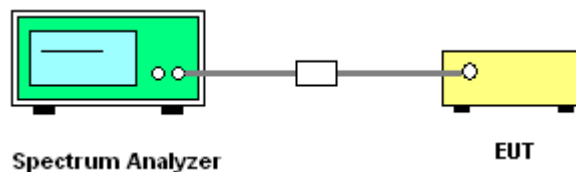





### 3.6.5 Test Result of Conducted Band Edges

Test Mode :	1Mbps	Temperature :	20~21°C
Test Channel :	00 and 78	Relative Humidity :	40~41%
		Test Engineer :	Zhi Lu

Low Band Edge Plot on Channel 00

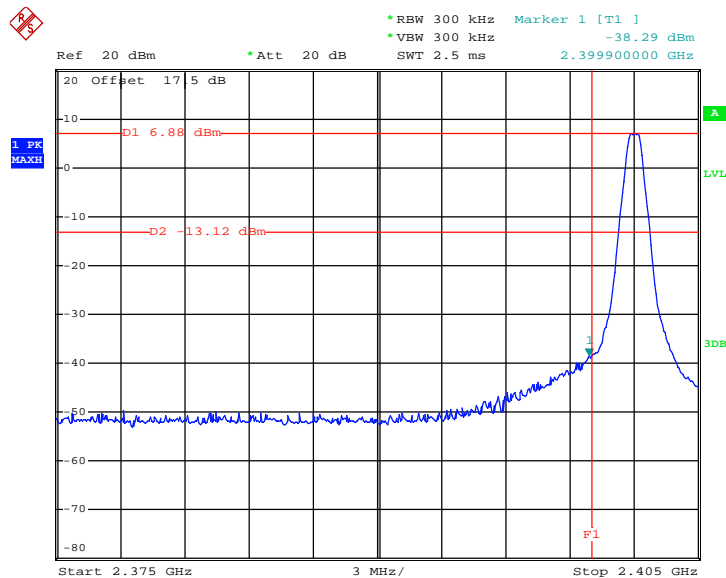

Date: 14.DEC.2012 16:18:07

High Band Edge Plot on Channel 78

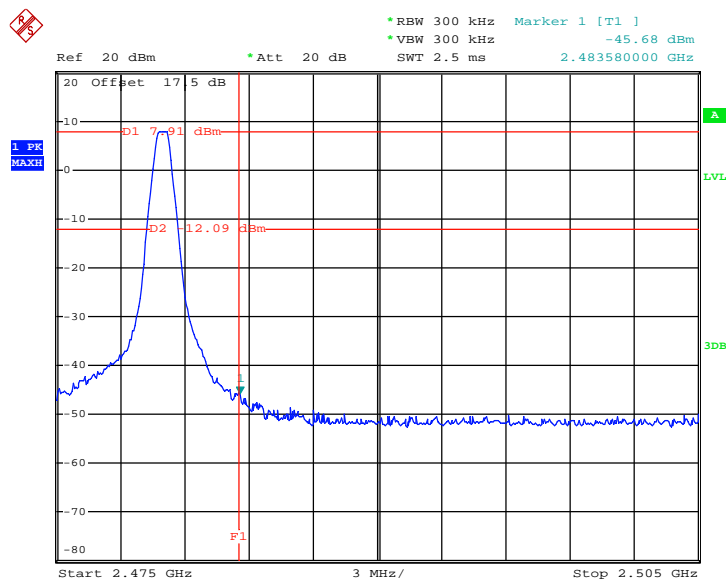

Date: 14.DEC.2012 16:17:19



Test Mode :	2Mbps	Temperature :	20~21°C
Test Channel :	00 and 78	Relative Humidity :	40~41%
		Test Engineer :	Zhi Lu

Low Band Edge Plot on Channel 00

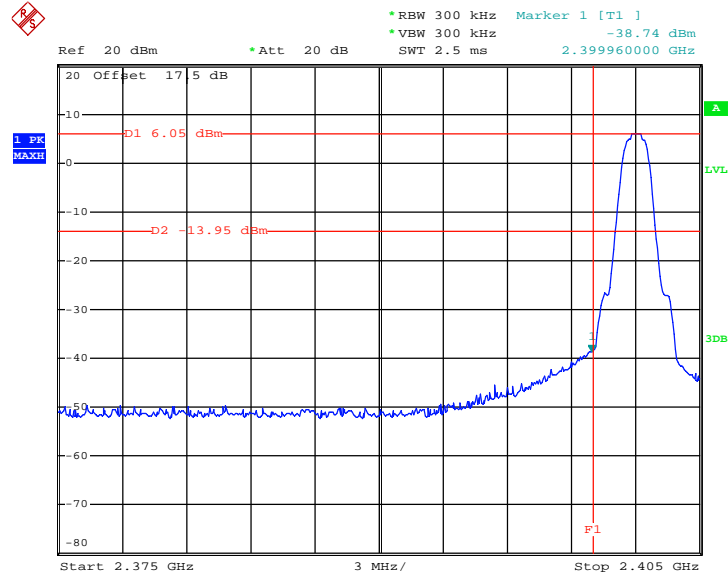

Date: 14.DEC.2012 16:15:12

High Band Edge Plot on Channel 78

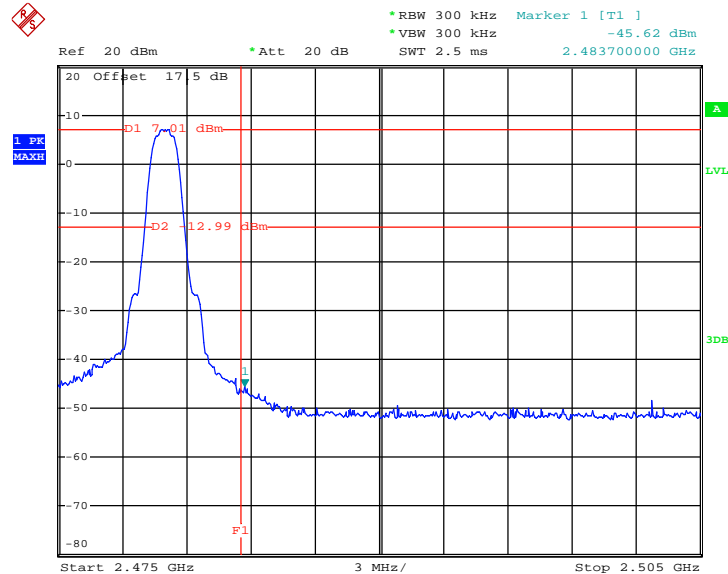

Date: 14.DEC.2012 16:13:46



Test Mode :	3Mbps	Temperature :	20~21°C
Test Channel :	00 and 78	Relative Humidity :	40~41%
		Test Engineer :	Zhi Lu

Low Band Edge Plot on Channel 00

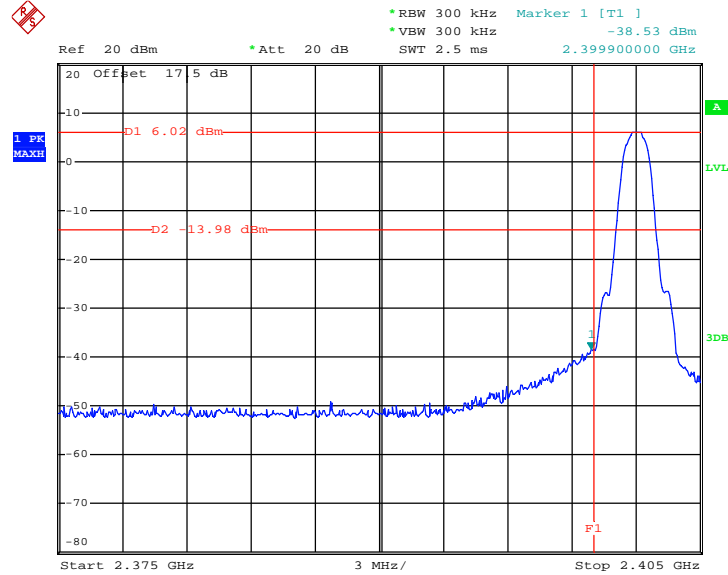

Date: 14.DEC.2012 16:09:52

High Band Edge Plot on Channel 78

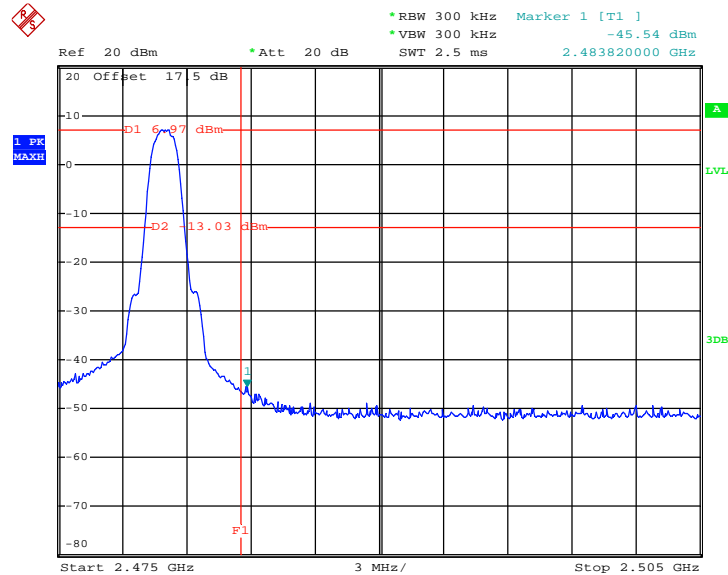

Date: 14.DEC.2012 16:08:40



### 3.6.6 Test Result of Conducted Hopping Mode Band Edges

Test Mode :	1Mbps	Temperature :	20~21°C
Test Engineer :	Zhi Lu	Relative Humidity :	40~41%

Hopping Mode Low Band Edge Plot on Channel 00

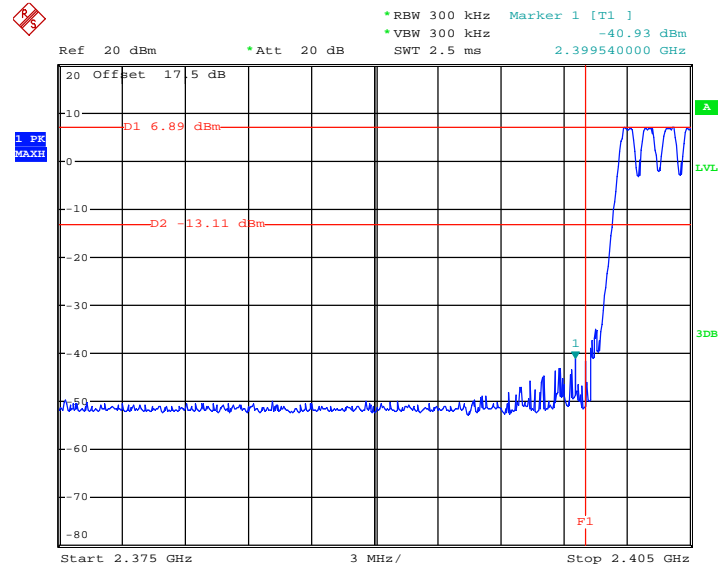

Date: 14.DEC.2012 16:21:41

Hopping Mode High Band Edge Plot on Channel 78

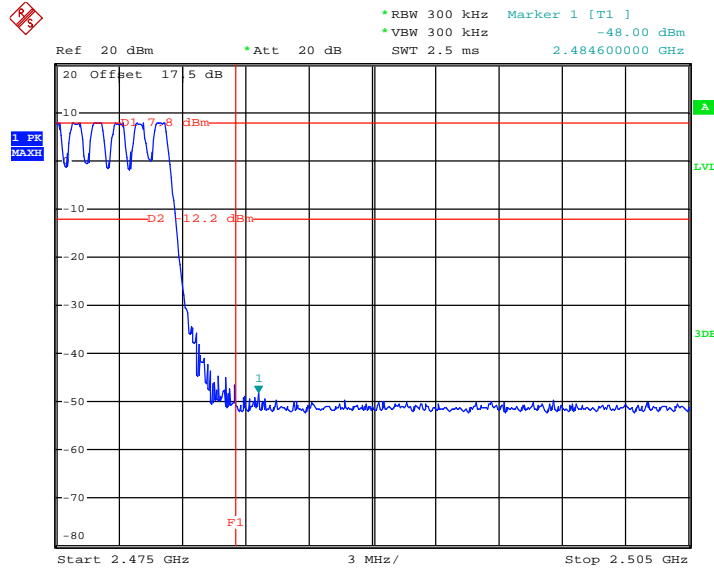

Date: 14.DEC.2012 16:20:34



Test Mode :	2Mbps	Temperature :	20~21°C
Test Engineer :	Zhi Lu	Relative Humidity :	40~41%

Hopping Mode Low Band Edge Plot on Channel 00

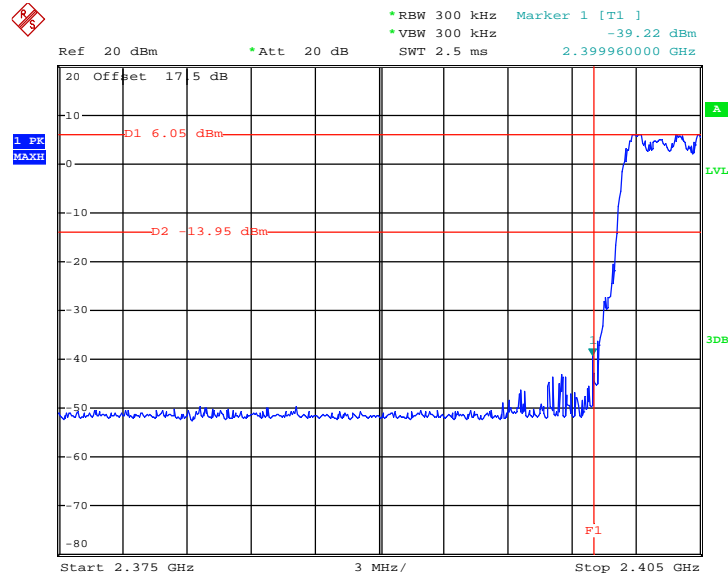

Date: 14.DEC.2012 16:24:50

Hopping Mode High Band Edge Plot on Channel 78

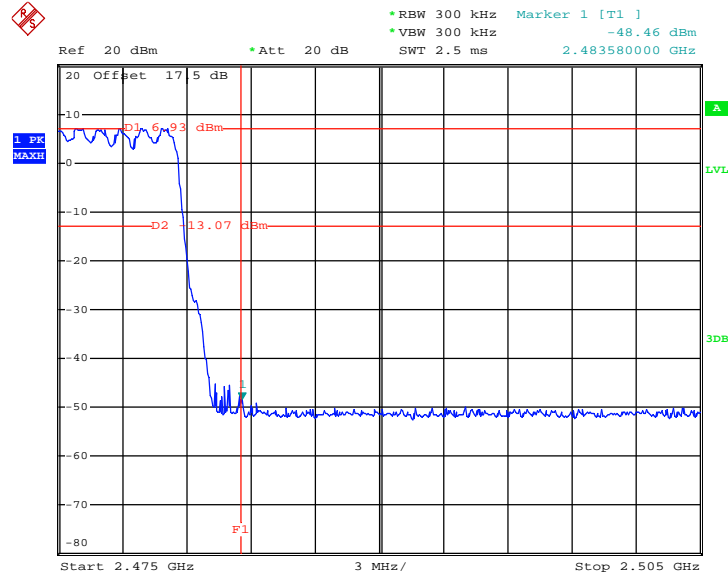

Date: 14.DEC.2012 16:23:43



Test Mode :	3Mbps	Temperature :	20~21°C
Test Engineer :	Zhi Lu	Relative Humidity :	40~41%

Hopping Mode Low Band Edge Plot on Channel 00

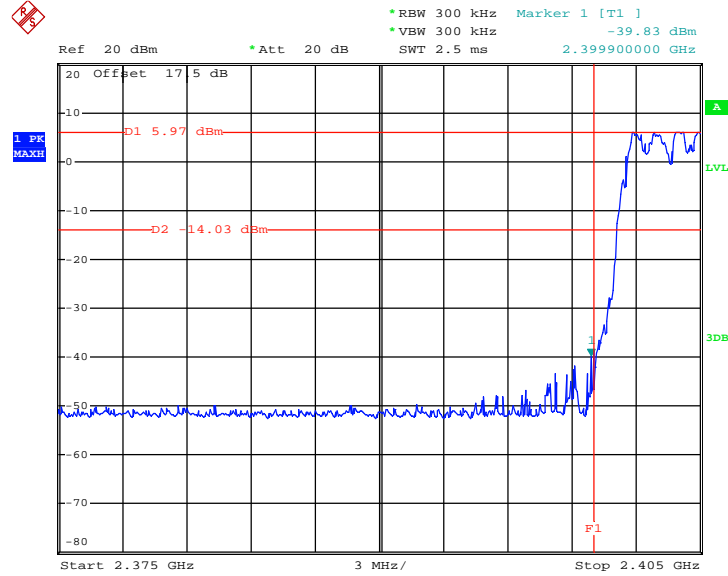

Date: 14.DEC.2012 16:27:55

Hopping Mode High Band Edge Plot on Channel 78

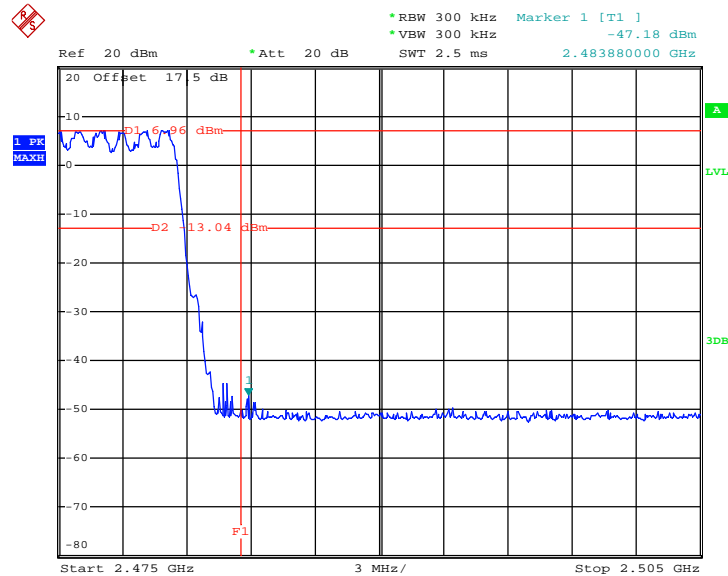

Date: 14.DEC.2012 16:26:49

## 3.7 Conducted Spurious Emission Measurement

### 3.7.1 Limit of Spurious Emission Measurement

In any 100 KHz bandwidth outside the intentional radiation frequency band, the radio frequency power shall be at least 20 dB below the highest level of the radiated power. In addition, radiated emissions which fall in the restricted bands must also comply with the radiated emission limits.

### 3.7.2 Measuring Instruments

See list of measuring instruments of this test report.

### 3.7.3 Test Procedure

1. The testing follows the guidelines in Spurious RF Conducted Emissions of FCC Public Notice DA 00-705 Measurement Guidelines
2. The RF output of EUT was connected to the spectrum analyzer by RF cable and attenuator. The path loss was compensated to the results for each measurement.
3. Set to the maximum power setting and enable the EUT transmit continuously.
4. Set RBW = 100 KHz, VBW = 300KHz, scan up through 10th harmonic. All harmonics / spurs must be at least 20 dB down from the highest emission level within the authorized band as measured with a 100 KHz RBW.
5. Measure and record the results in the test report.

### 3.7.4 Test Setup

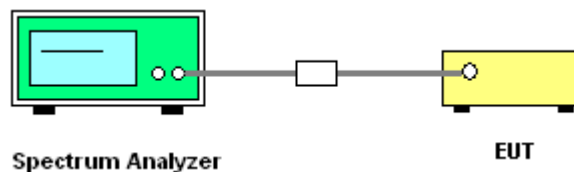



### 3.7.5 Test Results

Test Mode :	3Mbps	Temperature :	20~21°C
Test Channel :	00	Relative Humidity :	40~41%
		Test Engineer :	Zhi Lu

Conducted Spurious Emission Plot between 30MHz ~ 3 GHz

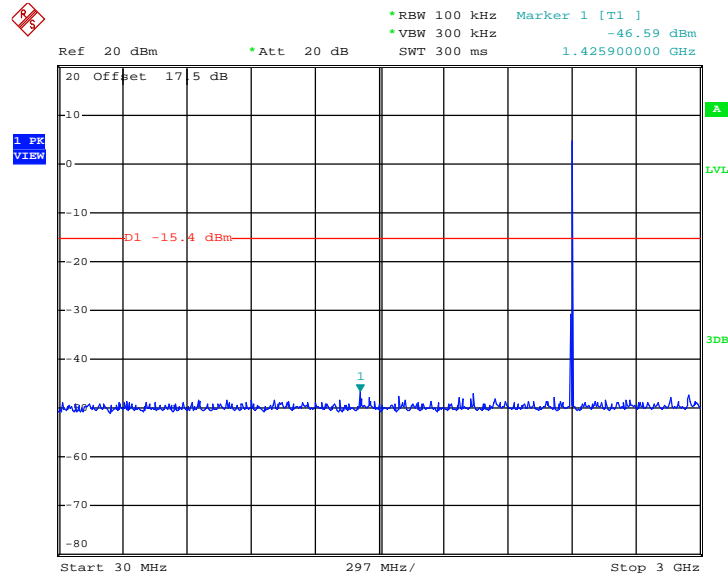

Date: 14.DEC.2012 16:46:14

Conducted Spurious Emission Plot between 2 GHz ~ 25 GHz

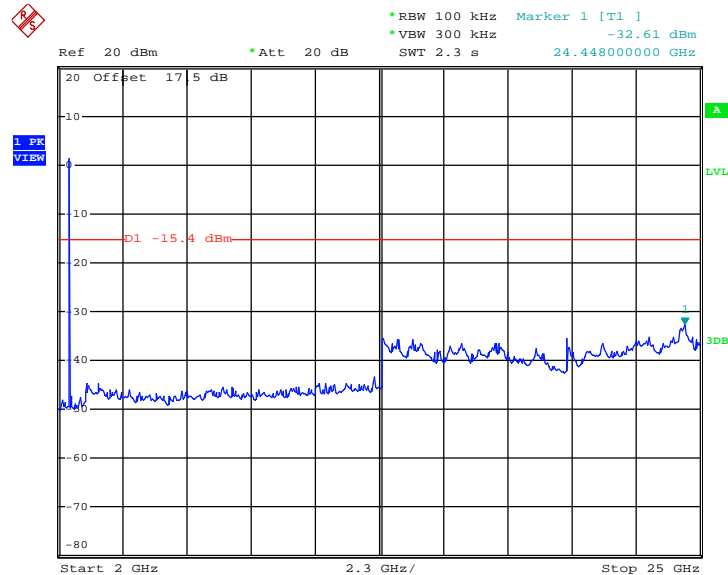

Date: 14.DEC.2012 16:47:05





Test Mode :	3Mbps	Temperature :	20~21°C
Test Channel :	39	Relative Humidity :	40~41%
		Test Engineer :	Zhi Lu

Conducted Spurious Emission Plot between 30MHz ~ 3 GHz

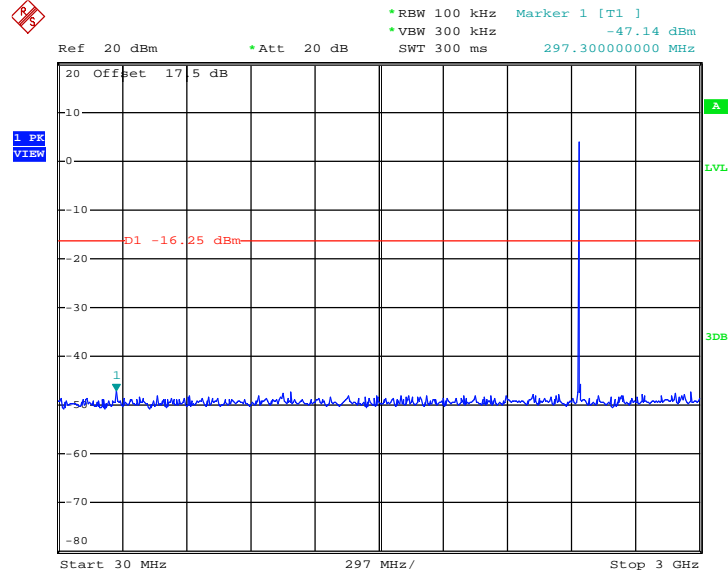

Date: 14.DEC.2012 16:48:02

Conducted Spurious Emission Plot between 2 GHz ~ 25 GHz

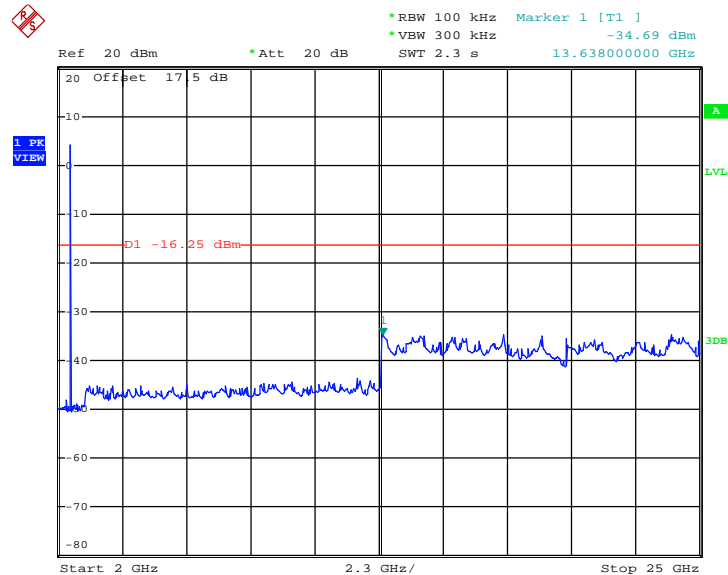

Date: 4.JAN.2013 12:35:45



Test Mode :	3Mbps	Temperature :	20~21°C
Test Channel :	78	Relative Humidity :	40~41%
		Test Engineer :	Zhi Lu

Conducted Spurious Emission Plot between 30MHz ~ 3 GHz

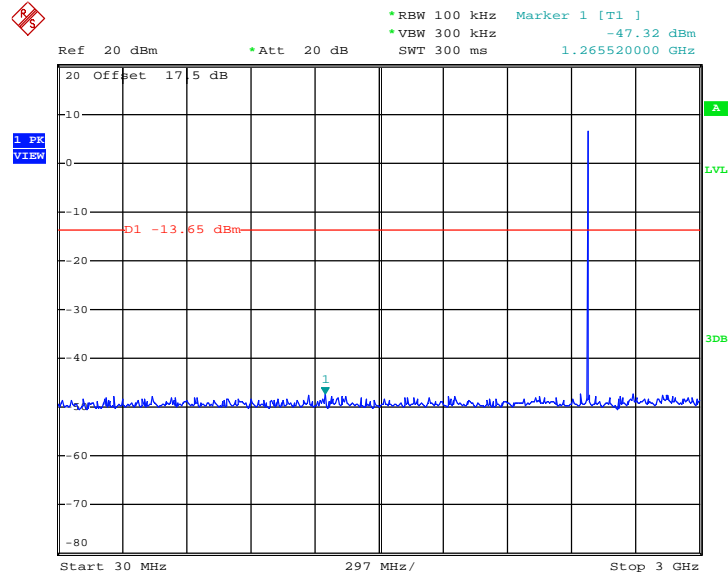

Date: 14.DEC.2012 16:49:39

Conducted Spurious Emission Plot between 2 GHz ~ 25 GHz

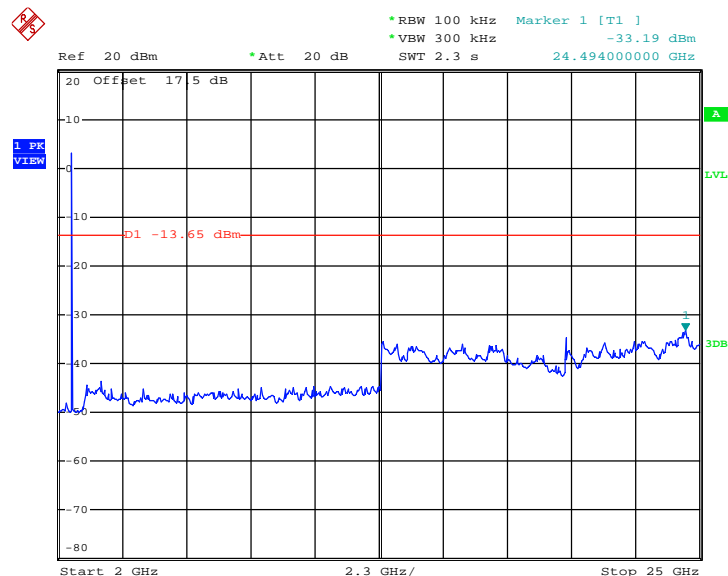

Date: 14.DEC.2012 16:50:14

### 3.8 Radiated Band Edges and Spurious Emission Measurement

#### 3.8.1 Limit of Radiated Band Edges and Spurious Emission

In any 100 KHz bandwidth outside the intentional radiator frequency band, all harmonics/spurious must be at least 20 dB below the highest emission level within the authorized band. In addition, radiated emissions which fall in the restricted bands must also comply with the FCC section 15.209 limits as below.

Frequency (MHz)	Field Strength (microvolts/meter)	Measurement Distance (meters)
0.009 – 0.490	2400/F(KHz)	300
0.490 – 1.705	24000/F(KHz)	30
1.705 – 30.0	30	30
30 – 88	100	3
88 – 216	150	3
216 - 960	200	3
Above 960	500	3

#### 3.8.2 Measuring Instruments

See list of measuring instruments of this test report.



### 3.8.3 Test Procedures

1. The testing follows the guidelines in Spurious Radiated Emissions of FCC Public Notice DA 00-705 Measurement Guidelines and fulfills ANSI C63.4-2003 and the guidelines in ANSI C63.10-2009 test site requirement.
2. The EUT was placed on a turntable with 0.8 meter above ground.
3. The EUT was set 3 meters from the interference receiving antenna, which was mounted on the top of a variable height antenna tower.
4. For each suspected emission, the EUT was arranged to its worst case and then tune the Antenna tower (from 1 m to 4 m) and turntable (from 0 degree to 360 degrees) to find the maximum reading. A pre-amp and a high pass filter are used for the test in order to get better signal level to comply with the guidelines.
5. Set to the maximum power setting and enable the EUT transmit continuously.
6. For measurement below 1GHz, If the emission level of the EUT measured by the peak detector is 3 dB lower than the applicable limit, the peak emission level will be reported. Otherwise, the emission measurement will be repeated using the quasi-peak detector and reported.
7. Use the following spectrum analyzer settings:
  - (1) Span shall wide enough to fully capture the emission being measured;
  - (2) Set RBW=100 KHz for  $f < 1$  GHz, RBW=1MHz for  $f > 1$ GHz ; VBW  $\geq$  RBW; Sweep = auto; Detector function = peak; Trace = max hold for peak
  - (3) For average measurement: use duty cycle correction factor method per 15.35(c).  
Duty cycle = On time/100 milliseconds  
On time =  $N_1 * L_1 + N_2 * L_2 + \dots + N_{n-1} * L_{n-1} + N_n * L_n$   
Where  $N_1$  is number of type 1 pulses,  $L_1$  is length of type 1 pulses, etc.  
Average Level = Peak Level +  $20 * \log(\text{Duty cycle})$
8. Corrected Reading: Antenna Factor + Cable Loss + Read Level - Preamp Factor = Level

Note: The average levels were calculated from the peak level corrected with duty cycle correction factor (24.79dB) derived from  $20 \log(\text{dwell time}/100\text{ms})$ .

### 3.8.4 Test Setup

For radiated emissions below 30MHz

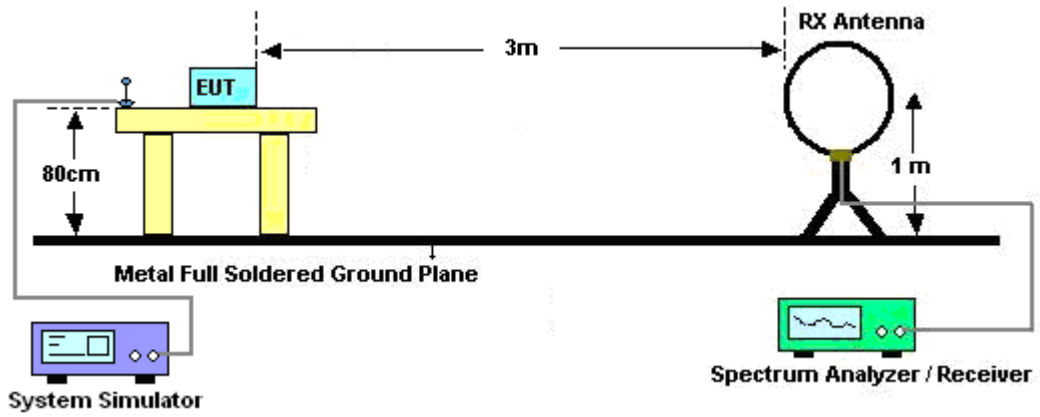

For radiated emissions from 30MHz to 1GHz

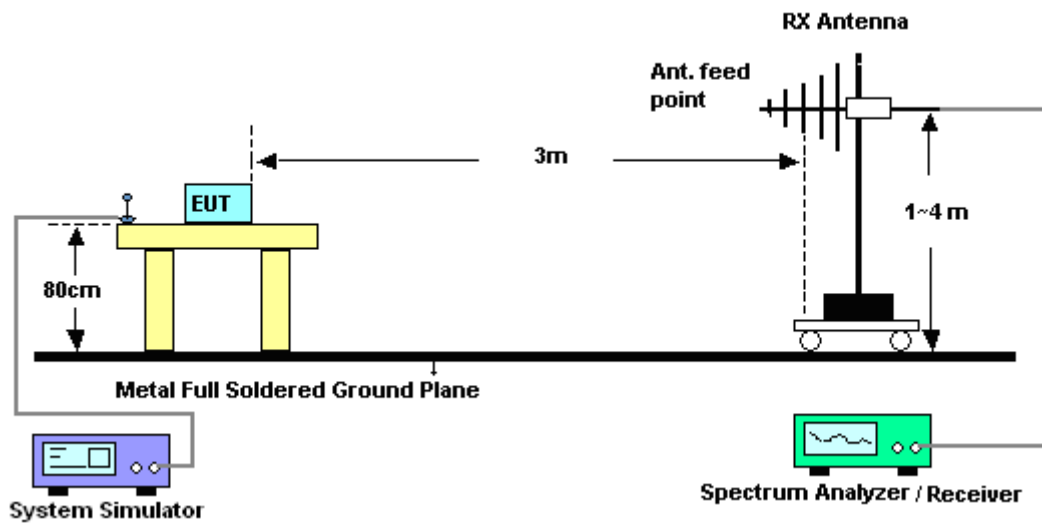

For radiated emissions above 1GHz

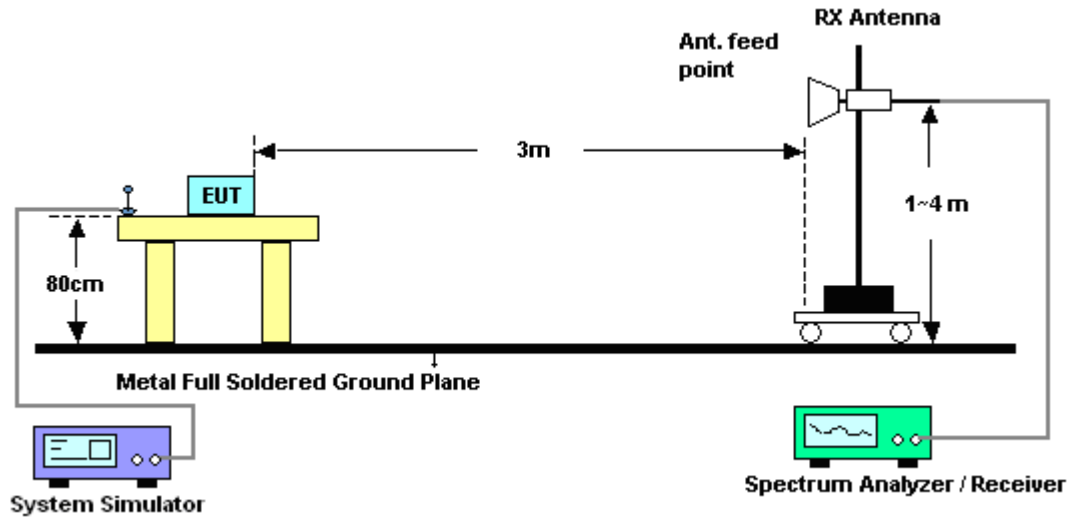

### 3.8.5 Test Results of Radiated Emissions (9 KHz ~ 30 MHz)

The low frequency, which started from 9 KHz to 30MHz, was pre-scanned and the result which was 20dB lower than the limit line per 15.31(o) was not reported.

### 3.8.6 Duty cycle correction factor for average measurement

#### 3DH5 on time/100ms (One Pulse) Plot on Channel 39

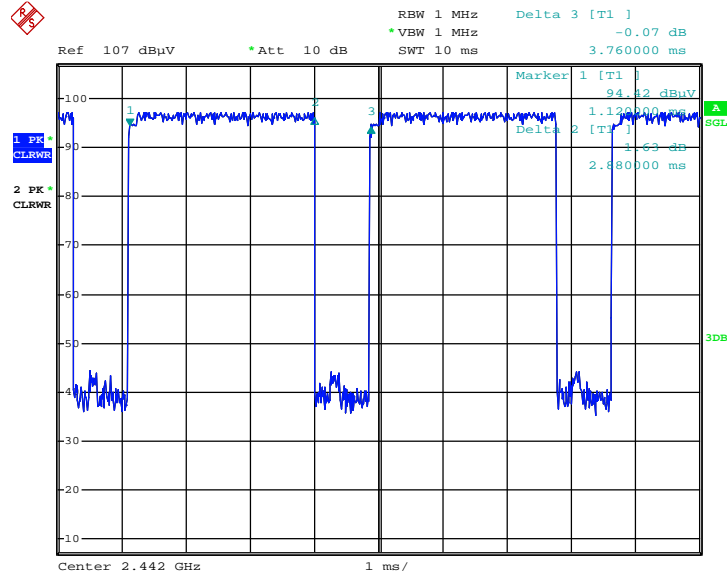

Date: 19.DEC.2012 20:38:29

#### 3DH5 on time/100ms (Count Pulses) Plot on Channel 39

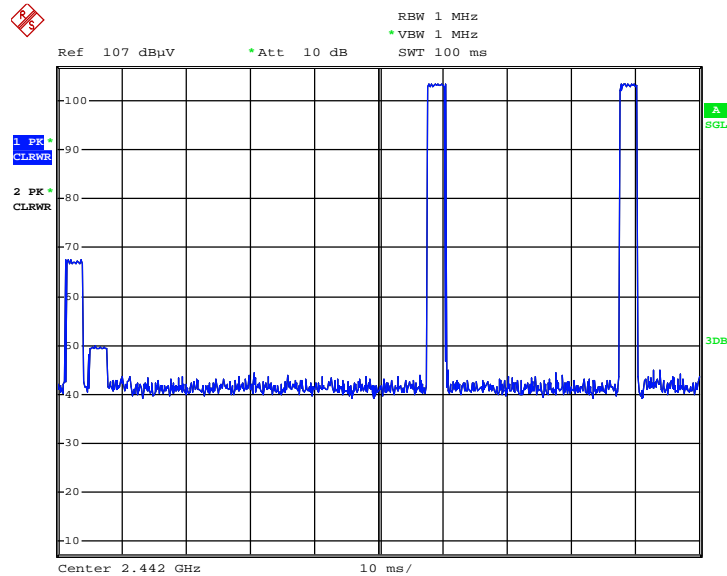

Date: 19.DEC.2012 20:39:05

**Note:**

1. Duty cycle = on time/100 milliseconds = 2 \* 2.88 / 100 = 5.76 %
2. Duty cycle correction factor = 20\*log(Duty cycle) = -24.79 dB
3. 3DH5 has the highest duty cycle and is reported.



3.8.7 Test Result of Radiated Band Edges

Test Mode :	3Mbps	Temperature :	22~23°C
Test Channel :	00	Relative Humidity :	41~42%
		Test Engineer :	Steven Hao

ANTENNA POLARITY : HORIZONTAL										
Frequency ( MHz )	Level ( dBμV/m )	Over Limit ( dB )	Limit Line ( dBμV/m )	Read Level ( dBμV )	Antenna Factor ( dB )	Cable Loss ( dB )	Preamp Factor ( dB )	Ant Pos ( cm )	Table Pos ( deg )	Remark
2367.06	48.23	-25.77	74	44.85	32.81	2.08	31.51	100	18	Peak
2367.06	23.44	-30.56	54	-	-	-	-	-	-	Average

ANTENNA POLARITY : VERTICAL										
Frequency ( MHz )	Level ( dBμV/m )	Over Limit ( dB )	Limit Line ( dBμV/m )	Read Level ( dBμV )	Antenna Factor ( dB )	Cable Loss ( dB )	Preamp Factor ( dB )	Ant Pos ( cm )	Table Pos ( deg )	Remark
2328.36	50.54	-23.46	74	47.23	32.76	2.06	31.51	105	136	Peak
2328.36	25.75	-28.25	54	-	-	-	-	-	-	Average

**Note:** The average levels were calculated from the peak level corrected with duty cycle correction factor (24.79dB) derived from 20log (dwell time/100ms).

For example: Average level = 50.54dBuV/m – 24.79 (dB) = 25.75dBuV/m.

Test Mode :	3Mbps	Temperature :	22~23°C
Test Channel :	78	Relative Humidity :	41~42%
		Test Engineer :	Steven Hao

ANTENNA POLARITY : HORIZONTAL										
Frequency ( MHz )	Level ( dBμV/m )	Over Limit ( dB )	Limit Line ( dBμV/m )	Read Level ( dBμV )	Antenna Factor ( dB )	Cable Loss ( dB )	Preamp Factor ( dB )	Ant Pos ( cm )	Table Pos ( deg )	Remark
2483.5	65.92	-8.08	74	62.26	33.01	2.16	31.51	100	15	Peak
2483.5	41.13	-12.87	54	-	-	-	-	-	-	Average

ANTENNA POLARITY : VERTICAL										
Frequency ( MHz )	Level ( dBμV/m )	Over Limit ( dB )	Limit Line ( dBμV/m )	Read Level ( dBμV )	Antenna Factor ( dB )	Cable Loss ( dB )	Preamp Factor ( dB )	Ant Pos ( cm )	Table Pos ( deg )	Remark
2483.5	56.54	-17.46	74	52.88	33.01	2.16	31.51	100	330	Peak
2483.5	31.75	-22.25	54	-	-	-	-	-	-	Average



**3.8.8 Test Result of Radiated Emission (30 MHz ~ 10<sup>th</sup> Harmonic)**

NOTE: Below 1GHz for radiated emission measurement, pre-scanned all test modes and only choose the worst case mode was recorded in the report.

<b>Test Mode :</b>	3Mbps	<b>Temperature :</b>	22~23°C
<b>Test Channel :</b>	00	<b>Relative Humidity :</b>	41~42%
<b>Test Engineer :</b>	Steven Hao	<b>Polarization :</b>	Horizontal
<b>Remark :</b>	1. 2402 MHz is fundamental signal which can be ignored. 2. 7206 MHz is not within a restricted band, and its limit line is 20dB below the highest emission level. 3. Average measurement was not performed if peak level went lower than the average limit.		

Frequency ( MHz )	Level ( dBμV/m )	Over Limit ( dB )	Limit Line ( dBμV/m )	Read Level (dBμV)	Antenna Factor ( dB )	Cable Loss ( dB )	Preamp Factor ( dB )	Ant Pos ( cm )	Table Pos ( deg )	Remark
2399	69.03	-16.76	85.79	65.57	32.86	2.11	31.51	100	18	Peak
2402	105.79	-	-	102.33	32.86	2.11	31.51	100	18	Peak
2402	81	-	-	-	-	-	-	-	-	Average
4804	48.11	-25.89	74	41.4	35.17	3.08	31.54	100	21	Peak
7206	49.32	-36.47	85.79	40.88	36.16	3.24	30.96	100	26	Peak

**Note:** Other harmonics are lower than background noise.



<b>Test Mode :</b>	3Mbps	<b>Temperature :</b>	22~23°C
<b>Test Channel :</b>	00	<b>Relative Humidity :</b>	41~42%
<b>Test Engineer :</b>	Steven Hao	<b>Polarization :</b>	Vertical
<b>Remark :</b>	1. 2402 MHz is fundamental signal which can be ignored. 2. 7206 MHz is not within a restricted band, and its limit line is 20dB below the highest emission level. 3. Average measurement was not performed if peak level went lower than the average limit.		

Frequency ( MHz )	Level ( dBμV/m )	Over Limit ( dB )	Limit Line ( dBμV/m )	Read Level (dBμV)	Antenna Factor ( dB )	Cable Loss ( dB )	Preamp Factor ( dB )	Ant Pos ( cm )	Table Pos ( deg )	Remark
2399	58.09	-16.18	74.27	54.63	32.86	2.11	31.51	105	136	Peak
2402	94.27	-	-	90.81	32.86	2.11	31.51	105	136	Peak
2402	69.48	-	-	-	-	-	-	-	-	Average
4804	49.23	-24.77	74	42.52	35.17	3.08	31.54	100	300	Peak
7206	50.04	-24.23	74.27	41.6	36.16	3.24	30.96	100	306	Peak

**Note:** Other harmonics are lower than background noise.



<b>Test Mode :</b>	3Mbps	<b>Temperature :</b>	22~23°C
<b>Test Channel :</b>	39	<b>Relative Humidity :</b>	41~42%
<b>Test Engineer :</b>	Steven Hao	<b>Polarization :</b>	Horizontal
<b>Remark :</b>	1. 2441 MHz is fundamental signal which can be ignored. 2. Average measurement was not performed if peak level went lower than the average limit.		

Frequency ( MHz )	Level ( dBμV/m )	Over Limit ( dB )	Limit Line ( dBμV/m )	Read Level (dBμV)	Antenna Factor ( dB )	Cable Loss ( dB )	Preamp Factor ( dB )	Ant Pos ( cm )	Table Pos ( deg )	Remark
2441	105.61	-	-	102.03	32.95	2.14	31.51	100	12	Peak
2441	80.82	-	-	-	-	-	-	-	-	Average
4882	49.05	-24.95	74	42.27	35.18	3.12	31.52	100	16	Peak
7323	50.32	-23.68	74	41.84	36.21	3.21	30.94	100	18	Peak

**Note:** Other harmonics are lower than background noise.



<b>Test Mode :</b>	3Mbps	<b>Temperature :</b>	22~23°C
<b>Test Channel :</b>	39	<b>Relative Humidity :</b>	41~42%
<b>Test Engineer :</b>	Steven Hao	<b>Polarization :</b>	Vertical
<b>Remark :</b>	1. 2441 MHz is fundamental signal which can be ignored. 2. Average measurement was not performed if peak level went lower than the average limit.		

Frequency ( MHz )	Level ( dBμV/m )	Over Limit ( dB )	Limit Line ( dBμV/m )	Read Level (dBμV)	Antenna Factor ( dB )	Cable Loss ( dB )	Preamp Factor ( dB )	Ant Pos ( cm )	Table Pos ( deg )	Remark
2441	95.23	-	-	91.65	32.95	2.14	31.51	100	321	Peak
2441	70.44	-	-	-	-	-	-	-	-	Average
4882	49.08	-24.92	74	42.3	35.18	3.12	31.52	100	312	Peak
7323	50.48	-23.52	74	42	36.21	3.21	30.94	100	320	Peak

**Note:** Other harmonics are lower than background noise.



<b>Test Mode :</b>	3Mbps	<b>Temperature :</b>	22~23°C
<b>Test Channel :</b>	78	<b>Relative Humidity :</b>	41~42%
<b>Test Engineer :</b>	Steven Hao	<b>Polarization :</b>	Horizontal
<b>Remark :</b>	1. 2480 MHz is fundamental signal which can be ignored. 2. Average measurement was not performed if peak level went lower than the average limit.		

Frequency ( MHz )	Level ( dBμV/m )	Over Limit ( dB )	Limit Line ( dBμV/m )	Read Level (dBμV)	Antenna Factor ( dB )	Cable Loss ( dB )	Preamp Factor ( dB )	Ant Pos ( cm )	Table Pos ( deg )	Remark
30.317	19.33	-20.67	40	34.56	18	0.34	33.57	-	-	Peak
69.114	10.63	-29.37	40	38.42	5.28	0.52	33.59	-	-	Peak
100.934	13.94	-29.56	43.5	36.35	10.62	0.58	33.61	-	-	Peak
117.773	13.2	-30.3	43.5	34.38	11.8	0.62	33.6	-	-	Peak
256.521	14.62	-31.38	46	35.02	12.1	0.93	33.43	-	-	Peak
942.131	27.59	-18.41	46	37.58	20.7	1.75	32.44	100	181	Peak
2480	105.97	-	-	102.31	33.01	2.16	31.51	100	15	Peak
2480	81.18	-	-	-	-	-	-	-	-	Average
4960	48.47	-25.53	74	41.62	35.2	3.16	31.51	100	21	Peak
7440	50.33	-23.67	74	41.8	36.27	3.18	30.92	100	15	Peak

**Note:** Other harmonics are lower than background noise.



<b>Test Mode :</b>	3Mbps	<b>Temperature :</b>	22~23°C
<b>Test Channel :</b>	78	<b>Relative Humidity :</b>	41~42%
<b>Test Engineer :</b>	Steven Hao	<b>Polarization :</b>	Vertical
<b>Remark :</b>	1. 2480 MHz is fundamental signal which can be ignored. 2. Average measurement was not performed if peak level went lower than the average limit.		

Frequency ( MHz )	Level ( dBμV/m )	Over Limit ( dB )	Limit Line ( dBμV/m )	Read Level (dBμV)	Antenna Factor ( dB )	Cable Loss ( dB )	Preamp Factor ( dB )	Ant Pos ( cm )	Table Pos ( deg )	Remark
37.416	20.62	-19.38	40	40.17	13.7	0.38	33.63	-	-	Peak
47.826	23.39	-16.61	40	48.06	8.5	0.43	33.6	100	126	Peak
100.934	23.26	-20.24	43.5	45.67	10.62	0.58	33.61	-	-	Peak
129.015	19.72	-23.78	43.5	40.93	11.71	0.67	33.59	-	-	Peak
824.597	26.04	-19.96	46	36.92	20.16	1.64	32.68	-	-	Peak
942.131	28.74	-17.26	46	38.73	20.7	1.75	32.44	-	-	Peak
2480	94.69	-	-	91.03	33.01	2.16	31.51	100	329	Peak
2480	69.9	-	-	-	-	-	-	-	-	Average
4960	48.55	-25.45	74	41.7	35.2	3.16	31.51	100	312	Peak
7440	51	-23	74	42.47	36.27	3.18	30.92	100	332	Peak

**Note:** Other harmonics are lower than background noise.

### 3.9 AC Conducted Emission Measurement

#### 3.9.1 Limit of AC Conducted Emission

For equipment that is designed to be connected to the public utility (AC) power line, the radio frequency voltage that is conducted back onto the AC power line on any frequency or frequencies within the band 150 KHz to 30 MHz shall not exceed the limits in the following table.

Frequency of emission (MHz)	Conducted limit (dBuV)	
	Quasi-peak	Average
0.15-0.5	66 to 56*	56 to 46*
0.5-5	56	46
5-30	60	50

\*Decreases with the logarithm of the frequency.

#### 3.9.2 Measuring Instruments

See list of measuring instruments of this test report.

#### 3.9.3 Test Procedures

1. The test follows the guidelines in ANSI C63.4-2003 and ANSI C63.10-2009 test site requirement.
2. The EUT was placed 0.4 meter from the conducting wall of the shielding room was kept at least 80 centimeters from any other grounded conducting surface.
3. Connect EUT to the power mains through a line impedance stabilization network (LISN).
4. All the support units are connecting to the other LISN.
5. The LISN provides 50 ohm coupling impedance for the measuring instrument.
6. The FCC states that a 50 ohm, 50 microhenry LISN should be used.
7. Both sides of AC line were checked for maximum conducted interference.
8. The frequency range from 150 KHz to 30 MHz was searched.
9. Set the test-receiver system to Peak Detect Function and specified bandwidth with Maximum Hold Mode.

### 3.9.4 Test Setup

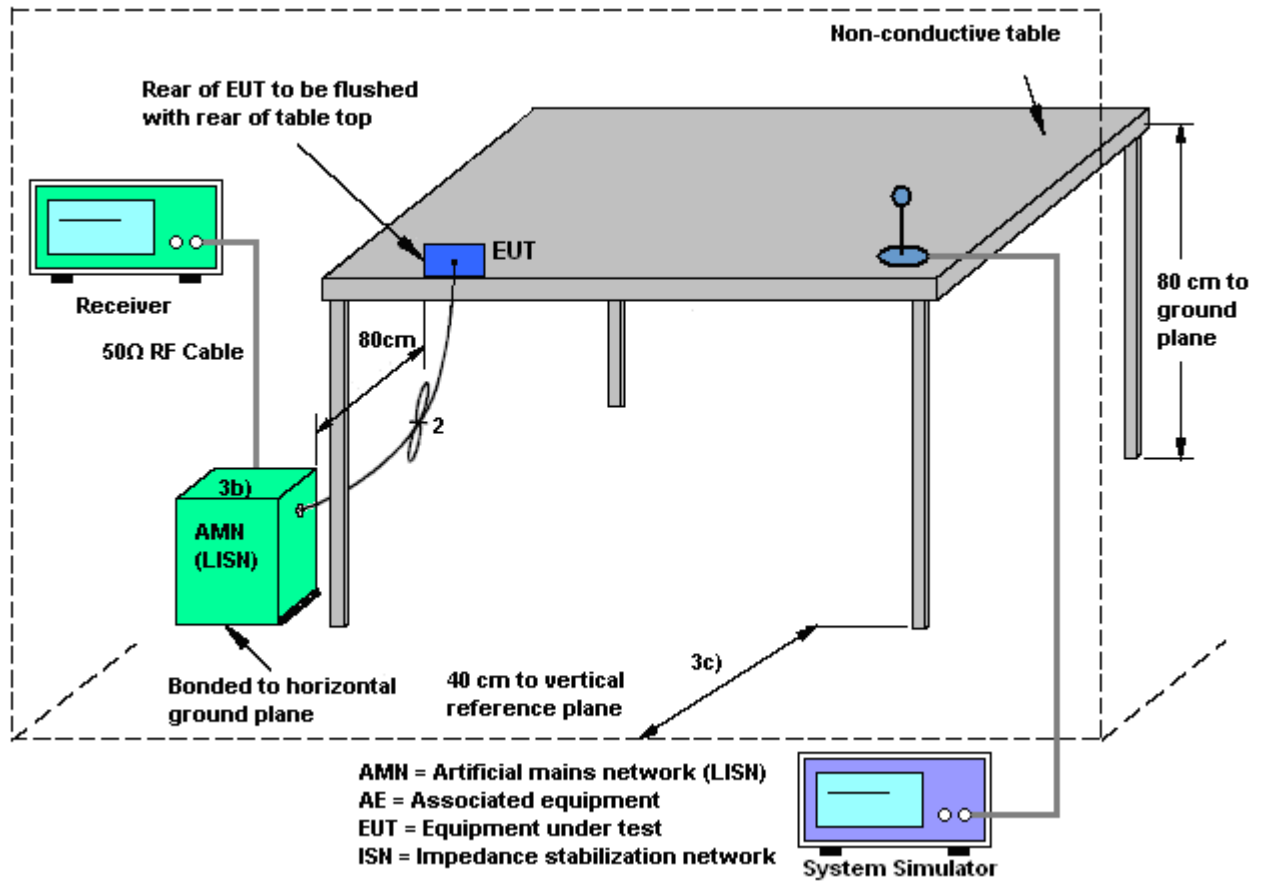





3.9.5 Test Result of AC Conducted Emission

Test Mode :	Mode 1	Temperature :	19~20°C
Test Engineer :	Tom Wang	Relative Humidity :	39~40%
Test Voltage :	120Vac / 60Hz	Phase :	Line
Function Type :	CDMA2000 BC0 Idle + WLAN Link + Bluetooth Link + USB Cable (Charging from Adapter) + Earphone		
Remark :	All emissions not reported here are more than 10 dB below the prescribed limit.		

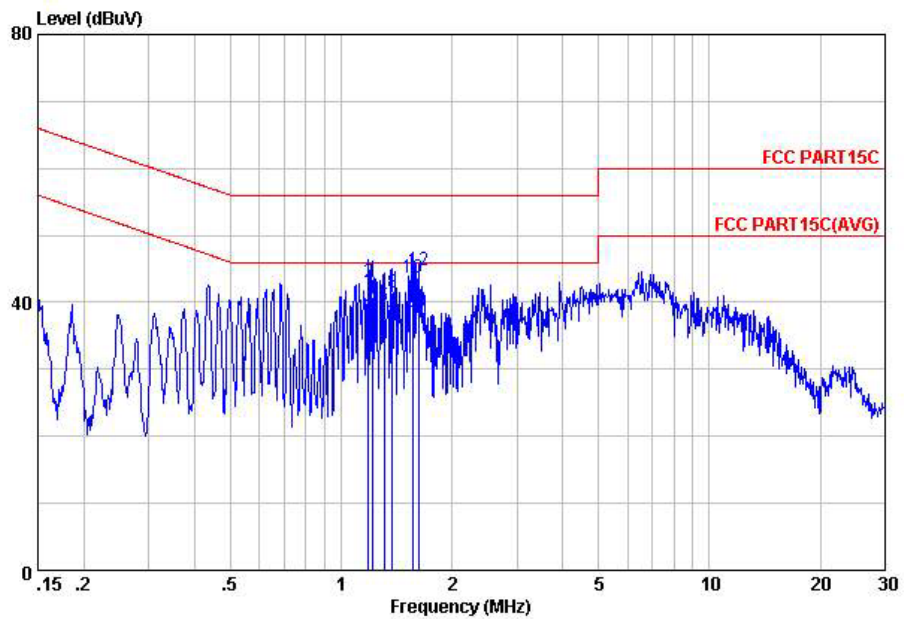

Site : C001-KS  
 Condition: FCC PART15C LISN-111230 LINE

	Freq	Level	Over	Limit	Read	LISN	Cable	Remark
	MHz	dBuV	Limit	Line	Level	Factor	Loss	
			dB	dBuV	dBuV	dB	dB	
1	1.18	37.98	-8.02	46.00	27.80	-0.10	10.28	Average
2	1.18	42.98	-13.02	56.00	32.80	-0.10	10.28	QP
3	1.22	38.78	-7.22	46.00	28.60	-0.10	10.28	Average
4	1.22	40.48	-15.52	56.00	30.30	-0.10	10.28	QP
5	1.31	39.38	-16.62	56.00	29.19	-0.10	10.29	QP
6	1.31	34.88	-11.12	46.00	24.69	-0.10	10.29	Average
7	1.37	36.68	-9.32	46.00	26.49	-0.10	10.29	Average
8	1.37	41.38	-14.62	56.00	31.19	-0.10	10.29	QP
9	1.56	38.49	-7.51	46.00	28.31	-0.11	10.29	Average
10	1.56	43.79	-12.21	56.00	33.61	-0.11	10.29	QP
11	1.62	38.69	-7.31	46.00	28.50	-0.11	10.30	Average
12	1.62	44.89	-11.11	56.00	34.70	-0.11	10.30	QP



Test Mode :	Mode 1	Temperature :	19~20°C
Test Engineer :	Tom Wang	Relative Humidity :	39~40%
Test Voltage :	120Vac / 60Hz	Phase :	Neutral
Function Type :	CDMA2000 BC0 Idle + WLAN Link + Bluetooth Link + USB Cable (Charging from Adapter) + Earphone		
Remark :	All emissions not reported here are more than 10 dB below the prescribed limit.		

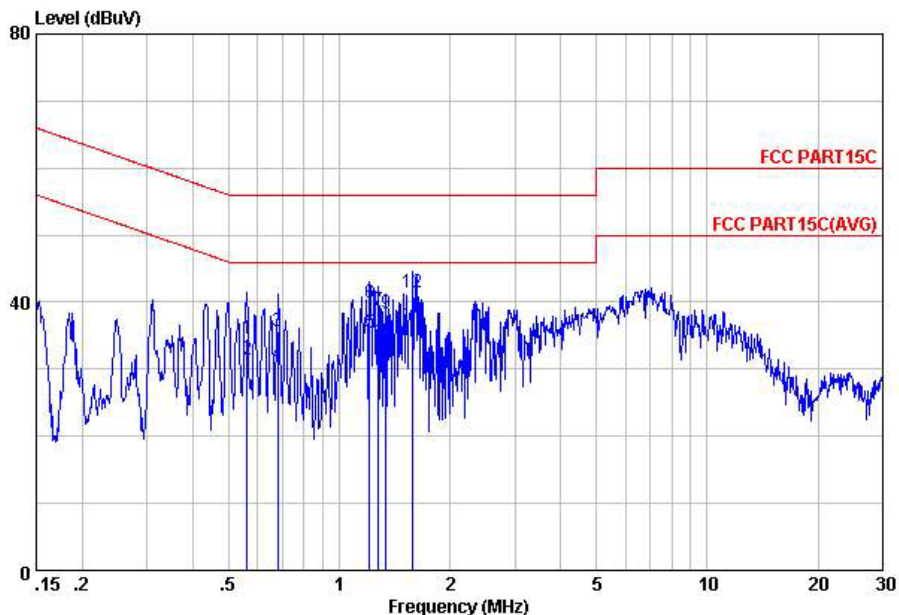

Site : C001-KS  
 Condition: FCC PART15C LISN-111230 NEUTRAL

	Freq	Level	Over	Limit	Read	LISN	Cable	Remark
	MHz	dBuV	Limit	Line	Level	Factor	Loss	
			dB	dBuV	dBuV	dB	dB	
1	0.56	34.58	-21.42	56.00	24.40	-0.08	10.26	QP
2	0.56	31.48	-14.52	46.00	21.30	-0.08	10.26	Average
3	0.68	35.59	-20.41	56.00	25.40	-0.08	10.27	QP
4	0.68	30.79	-15.21	46.00	20.60	-0.08	10.27	Average
5	1.21	35.49	-10.51	46.00	25.30	-0.09	10.28	Average
6	1.21	39.99	-16.01	56.00	29.80	-0.09	10.28	QP
7	1.28	38.69	-17.31	56.00	28.50	-0.10	10.29	QP
8	1.28	33.79	-12.21	46.00	23.60	-0.10	10.29	Average
9	1.34	38.29	-17.71	56.00	28.10	-0.10	10.29	QP
10	1.34	33.39	-12.61	46.00	23.20	-0.10	10.29	Average
11	1.59	36.49	-9.51	46.00	26.30	-0.10	10.29	Average
12	1.59	41.49	-14.51	56.00	31.30	-0.10	10.29	QP



## **3.10 Antenna Requirements**

### **3.10.1 Standard Applicable**

If directional gain of transmitting antennas is greater than 6dBi, the power shall be reduced by the same level in dB comparing to gain minus 6dBi. The use of a permanently attached antenna or of an antenna that uses a unique coupling to the intentional radiator shall be considered sufficient to comply with the FCC rule.

### **3.10.2 Antenna Connected Construction**

Non-standard connector used.

### **3.10.3 Antenna Gain**

The antenna peak gain of EUT is less than 6 dBi. Therefore, it is not necessary to reduce maximum peak output power limit.



## 4 List of Measuring Equipment

Instrument	Manufacturer	Model No.	Serial No.	Characteristics	Calibration Date	Test Date	Due Date	Remark
Spectrum Analyzer	R&S	FSP40	100319	9kHz~40GHz	Dec. 30, 2011	Dec. 13, 2012~ Dec. 14, 2012	Dec. 29, 2012	Conducted (TH01-KS)
DC Power Supply	GWINSTEK	GPS-3030D	E1884515	N/A	Aug. 22, 2012	Dec. 13, 2012~ Dec. 14, 2012	Aug. 21, 2013	Conducted (TH01-KS)
Thermal Chamber	Ten Billion	TTC-B3S	TBN-960502	N/A	Dec. 30, 2011	Dec. 13, 2012~ Dec. 14, 2012	Dec. 29, 2012	Conducted (TH01-KS)
Bluetooth Base Station	R&S	CBT	100783	N/A	Aug. 17, 2012	Dec. 13, 2012~ Dec. 14, 2012	Aug. 16, 2013	Conducted (TH01-KS)
EMI Test Receiver	R&S	ESCI	100534	9kHz~3GHz	Nov. 08, 2012	Dec. 30, 2012	Nov. 07, 2013	Radiation (03CH01-KS)
Spectrum Analyzer	R&S	FSP30	100400	9kHz~30GHz	Jun. 01, 2012	Dec. 19, 2012~ Dec. 30, 2012	May 31, 2013	Radiation (03CH01-KS)
Bilog Antenna	SCHAFFNER	CBL6112D	23182	25MHz~2GHz	Dec. 07, 2012	Dec. 30, 2012	Dec. 06, 2013	Radiation (03CH01-KS)
Loop Antenna	R&S	HFH2-Z2	860004/ 001	9 kHz~30 MHz	Jul. 03, 2012	Dec. 30, 2012	Jul. 02, 2014	Radiation (03CH01-KS)
Double Ridge Horn Antenna	EMCO	3117	00075959	1GHz~18GHz	Jan. 07, 2012	Dec. 30, 2012	Jan. 06, 2013	Radiation (03CH01-KS)
Amplifier	com-power	PA-103A	161069	1MHz~1GHz	Jun. 01, 2012	Dec. 30, 2012	May 31, 2013	Radiation (03CH01-KS)
Amplifier	Agilent	8449B	3008A02370	1GHz~26.5GHz	Dec. 29, 2012	Dec. 30, 2012	Dec. 28, 2013	Radiation (03CH01-KS)
Active Horn Antenna	com-power	AHA-118	701023	1GHz~18GHz	Nov. 07, 2012	Dec. 30, 2012	Nov. 06, 2013	Radiation (03CH01-KS)
SHF-EHF Horn	Schwarzbeck	BBHA 9170	9170249	15GHz~40GHz	Nov. 23, 2012	Dec. 30, 2012	Nov. 22, 2013	Radiation (03CH01-KS)
Bluetooth Base Station	R&S	CBT	100783	N/A	Aug. 17, 2012	Dec. 30, 2012	Aug. 16, 2013	Radiation (03CH01-KS)
EMI Receiver	R&S	ESCI7	100768	9kHz~7GHz	Jun. 01, 2012	Dec. 31, 2012	May 31, 2013	Conduction (CO01-KS)
LISN	MessTec	AN3016	60103	9kHz~30MHz	Dec. 29, 2012	Dec. 31, 2012	Dec. 28, 2013	Conduction (CO01-KS)
LISN	MessTec	AN3016	60105	9kHz~30MHz	Dec. 29, 2012	Dec. 31, 2012	Dec. 28, 2013	Conduction (CO01-KS)
AC Power Source	Chroma	61602	ABP000000811	N/A	Nov. 15, 2012	Dec. 31, 2012	Nov. 14, 2013	Conduction (CO01-KS)
System Simulator	R&S	CMU200	837587/066	2G Full-Band	Dec. 29, 2012	Dec. 31, 2012	Dec. 28, 2013	Conduction (CO01-KS)

## 5 Uncertainty of Evaluation

### Uncertainty of Radiated Emission Measurement (30 MHz ~ 1000 MHz)

Measuring Uncertainty for a Level of Confidence of 95% ( $U = 2Uc(y)$ )	2.54
---	------

### Uncertainty of Radiated Emission Measurement (1 GHz ~ 40 GHz)

Measuring Uncertainty for a Level of Confidence of 95% ( $U = 2Uc(y)$ )	4.72
---	------

### Uncertainty of Conducted Emission Measurement (150 KHz ~ 30 MHz)

Measuring Uncertainty for a Level of Confidence of 95% ( $U = 2Uc(y)$ )	2.26
---	------



## **Appendix A. Photographs of EUT**

Please refer to Sporton report number EP2D1401 as below.