



August 29, 2003

**FEDERAL COMMUNICATIONS COMMISSION**

7435 Oakland Mills Road  
Columbia, MD 21046  
USA

**Subject: Type Acceptance Application under FCC 47 CFR, Parts 2 and 90 (Subpart I) - Non-Broadcast Radio Transceivers Operating in the frequency bands 806 - 821 MHz (25 kHz Channel Spacing) and 821-824 MHz (12.5 kHz Channel Spacing).**

**Applicant: Keycorp Limited**  
**Product: Mobile Payment Terminal**  
**Model: LP9100 / K78-204**  
**FCC ID: P3A-K78-YYY**



Dear Sir/Madam,

As appointed agent for Keycorp Limited, we would like to submit the application for certification of the above product. Please review all necessary files uploaded to FCC OET Laboratory Division Electronic Filing Site.



The Keycorp Limited Mobile Payment Terminal, Model LP9100 / K78-204 employs a Wavenet Technology Wireless OEM Modem Module certified by FCC (FCC ID: PQS-BM28001, on Dec. 2, 2002). Since, there is no change on the radio module's operation with exception to the duty cycle (from 10% to 30%), only the following tests are performed to ensure the continuing compliance with different enclosure and power supply conditions:



- (1) RF output power: to ensure the maximum power still meets the FCC Grant FCC ID: PQS-BM28001 so that the test results from this application can be used for the new application FCC ID: P3A-K78YYY.
- (2) Transmitter spurious/harmonic radiated emissions. These tests are performed to ensure that the new enclosure and packaging will not affect radiated emissions from the OEM radio transmitter module.
- (3) RF exposure evaluation for portable application (SAR).
- (4) 99% occupied bandwidth and emission masks



If you have any queries, please do not hesitate to contact us by our TOLL FREE number:

OUR TELEPHONE NO.: 1-877-765-4173



Yours truly,



Tri Minh Luu, P.Eng  
Vice President - Engineering



3000 Bristol Circle,  
Oakville, Ontario,  
Canada L6H 6G4

Tel.: (905) 829-1570  
Fax.: (905) 829-8050

Website: [www.ultratech-labs.com](http://www.ultratech-labs.com)  
Email: [vic@ultratech-labs.com](mailto:vic@ultratech-labs.com)

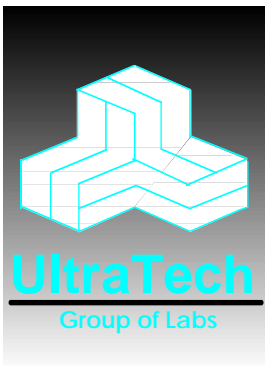

August 29, 2003

**Keycorp Limited.**  
Keycorp Tower, Level 5  
799 Pacific Highway  
Chatswood NSW 2067  
Sydney, Australia

**Attn.: Mr. Ken McAnulty**

**Subject: Type Acceptance Application under FCC 47 CFR, Parts 2 and 90 (Subpart I) - Non-Broadcast Radio Transceivers Operating in the frequency bands 806 - 821 MHz (25 kHz Channel Spacing) and 821-824 MHz (12.5 kHz Channel Spacing).**

**Product: Mobile Payment Terminal**  
**Model: LP9100 / K78-204**  
**FCC ID: P3A-K78-YYY**

Dear Mr. McAnulty,

The product sample has been tested in accordance with **FCC 47 CFR, Parts 2 and 90 (Subpart I) - Licensed Non-Broadcast Radio Transceiver Operating in the frequency band 806-821 and 821-824 MHz**, and the results and observation were recorded in the engineering report, Our File No.: KYC-009F90

Enclosed you will find copy of the engineering report. If you have any queries, please do not hesitate to contact us.

Yours truly,

Tri Minh Luu, P.Eng  
Vice President - Engineering

Encl.



31040/SIT



C-1376

Canada  
46390-2049

NVLAP  
200093-0



00-034



SL2-IN-E-1119R



entela

3000 Bristol Circle,  
Oakville, Ontario,  
Canada L6H 6G4

Tel.: (905) 829-1570  
Fax.: (905) 829-8050

Website: [www.ultratech-labs.com](http://www.ultratech-labs.com)  
Email: [vic@ultratech-labs.com](mailto:vic@ultratech-labs.com)



## TABLE OF CONTENTS

<b>EXHIBIT 1.</b>	<b>SUBMITTAL CHECK LIST .....</b>	<b>1</b>
<b>EXHIBIT 2.</b>	<b>INTRODUCTION.....</b>	<b>2</b>
2.1.	SCOPE .....	2
2.2.	RELATED SUBMITTAL(S)/GRANT(S).....	2
2.3.	NORMATIVE REFERENCES .....	2
<b>EXHIBIT 3.</b>	<b>PERFORMANCE ASSESSMENT .....</b>	<b>3</b>
3.1.	CLIENT INFORMATION.....	3
3.2.	EQUIPMENT UNDER TEST (EUT) INFORMATION.....	3
3.3.	EUT'S TECHNICAL SPECIFICATIONS .....	6
3.4.	LIST OF EUT'S PORTS.....	6
3.5.	ANCILLARY EQUIPMENT .....	6
<b>EXHIBIT 4.</b>	<b>EUT OPERATING CONDITIONS AND CONFIGURATIONS DURING TESTS.....</b>	<b>7</b>
4.1.	CLIMATE TEST CONDITIONS .....	7
4.2.	OPERATIONAL TEST CONDITIONS & ARRANGEMENT FOR TEST SIGNALS .....	7
<b>EXHIBIT 5.</b>	<b>SUMMARY OF TEST RESULTS.....</b>	<b>8</b>
5.1.	LOCATION OF TESTS.....	8
5.2.	APPLICABILITY & SUMMARY OF EMC EMISSION TEST RESULTS.....	8
5.3.	MODIFICATIONS INCORPORATED IN THE EUT FOR COMPLIANCE PURPOSES.....	8
<b>EXHIBIT 6.</b>	<b>MEASUREMENTS, EXAMINATIONS &amp; TEST DATA FOR EMC EMISSIONS.....</b>	<b>9</b>
6.1.	TEST PROCEDURES .....	9
6.2.	MEASUREMENT UNCERTAINTIES .....	9
6.3.	MEASUREMENT EQUIPMENT USED.....	9
6.4.	ESSENTIAL/PRIMARY FUNCTIONS AS DECLARED BY THE MANUFACTURER .....	9
6.5.	RF POWER OUTPUT @ FCC 2.1046 & 90.205.....	10
6.6.	EMISSION MASK @ FCC 2.1049, 90.208 & 90.210.....	11
6.7.	FIELD STRENGTH OF SPURIOUS RADIATION @ FCC 2.1053 & 90.210 .....	26
<b>EXHIBIT 7.</b>	<b>MEASUREMENT UNCERTAINTY .....</b>	<b>28</b>
7.1.	RADIATED EMISSION MEASUREMENT UNCERTAINTY.....	28
<b>EXHIBIT 8.</b>	<b>MEASUREMENT METHODS.....</b>	<b>29</b>
8.1.	RADIATED POWER MEASUREMENTS (ERP & EIRP) USING SUBSTITUTION .....	29
8.2.	EMISSION MASK .....	2

## EXHIBIT 1. SUBMITTAL CHECK LIST

Annex No.	Exhibit Type	Description of Contents	Quality Check (OK)
--	Test Report	Test Report	OK
1	Test Setup Photos	Photos # 1 to 12	OK
2	External Photos of EUT	Photos # 1 to 5	OK
3	Internal Photos of EUT	Photos of 1 to 15	OK
4	Cover Letters	<ul style="list-style-type: none"><li>• Letter from Ultratech for Certification Request</li><li>• Letter from the Applicant to appoint Ultratech to act as an agent</li><li>• Letter from the Applicant to request for Confidentiality Filing</li></ul>	
5	Attestation Statements	NA	N/A
6	ID Label/Location Info	ID Label Location of ID Label	OK
7	Block Diagrams	Block Diagrams	OK
8	Schematic Diagrams	Schematic Diagrams	OK
9	Parts List/Tune Up Info	Parts List/Tune Up Info	OK
10	Operational Description	Operational Description	OK
11	RF Exposure Info	RF Exposure Info	OK
12	Users Manual	Users Manual	OK

## EXHIBIT 2. INTRODUCTION

### 2.1. SCOPE

<b>Reference:</b>	FCC Parts 2 and 90
<b>Title:</b>	Telecommunication – 47 Code of Federal Regulations (CFR) Parts 2 & 90
<b>Purpose of Test:</b>	FCC Certification for Radio operating in the frequency band 806-821 and 821-824 MHz (12.5 and 25 kHz Channel Spacing).
<b>Test Procedures:</b>	Both conducted and radiated emissions measurements were conducted in accordance with American National Standards Institute ANSI C63.4 - American National Standard for Methods of Measurement of Radio-Noise Emissions from Low-Voltage Electrical and Electronic Equipment in the Range of 9 kHz to 40 GHz.

### 2.2. RELATED SUBMITTAL(S)/GRANT(S)

None.

### 2.3. NORMATIVE REFERENCES

Publication	Year	Title
FCC CFR Parts 0-19, 80-End	2002	Code of Federal Regulations – Telecommunication
ANSI C63.4	1992	American National Standard for Methods of Measurement of Radio-Noise Emissions from Low-Voltage Electrical and Electronic Equipment in the Range of 9 kHz to 40 GHz
CISPR 22 & EN 55022	1997 1998	Limits and Methods of Measurements of Radio Disturbance Characteristics of Information Technology Equipment
CISPR 16-1	1999	Specification for Radio Disturbance and Immunity measuring apparatus and methods

## EXHIBIT 3. PERFORMANCE ASSESSMENT

### 3.1. CLIENT INFORMATION

APPLICANT	
<b>Name:</b>	Keycorp Limited
<b>Address:</b>	Keycorp Tower, Level 5 799 Pacific Highway Chatswood NSW 2067 Sydney, Australia
<b>Contact Person:</b>	Mr. Ken McAnulty Phone #: +61 2 9415 2900 Fax #: +61 2 9415 1363 Email Address: kmcanulty@keycorp.net

MANUFACTURER	
<b>Name:</b>	Keycorp Limited
<b>Address:</b>	Keycorp Tower, Level 5 799 Pacific Highway Chatswood NSW 2067 Sydney, Australia
<b>Contact Person:</b>	Mr. Ken McAnulty Phone #: +61 2 9415 2900 Fax #: +61 2 9415 1363 Email Address: kmcanulty@keycorp.net

### 3.2. EQUIPMENT UNDER TEST (EUT) INFORMATION

The following information (with the exception of the Date of Receipt) has been supplied by the applicant.

<b>Brand Name:</b>	Keycorp Limited
<b>Product Name:</b>	Mobile Payment Terminal
<b>Model Name or Number:</b>	LP9100 / K78-204
<b>Type of Equipment:</b>	Terminal Equipment
<b>External Power Supply:</b>	4.8 Vdc
<b>Transmitting/Receiving Antenna Type:</b>	Non-integral

## MOBILE PAYMENT TERMINAL - PRODUCT DESCRIPTION

The device is a payment terminal used in both mobile and fixed applications. The terminal is capable of supporting magnetic card and smart card transactions by using wireless data communication.

The terminal features a printer module, a battery module, user interface including a display, an integrated wireless modem module and a dial up modem. The terminal may also be used in a fixed configuration through external communication ports.

The terminal provides the following features:

- (a) Credit/debit transactions off-line or on-line through the internally fitted wireless modem module.
- (b) Smart card transactions
- (c) Print receipts through the integrated printer or an external device.

Storage of transaction logs on a removable storage media

**Model Number:-** The Model number of the unit may be either K78-204 or LP 9100. There is no difference between the two units. The purpose of the two model numbers is for distribution purposes.

**Magnetic Card Reader:-** The terminal supports a magnetic card reader.

**Customer and Merchant Smart Card Slots:-** The supports two full size smart cards, one for the merchant and one for the customer. Each card is fully enclosed within the K78-204/LP9100.

**SAM Slots:-** The Terminal supports 1 SAM module.

**LCD:-** The terminal provides a 128(h) x 64(v) LCD monochrome graphics display.

**Power Switch:-** The power switch on the device prevents accidental powering on or off.

**Printer:-** The terminal includes a thermal printer.

**Communications Module:** The terminal includes an internal wireless modem module.



### **PSTN Modem**

The terminal provides a modem that offers a dial up connection through the PSTN.

The modem supports an asynchronous connection and is capable of operating at speeds of up to 2400 baud.

The PSTN modem and the Wireless modem cannot operate simultaneously.

#### External Cable

The terminal provides an external port connector to support RS 232 ports through external interface cable 763-578059.

The external cable may be used for connection of external devices such as an external modem, printer or PC.

### **Power Supply:**

The terminal is normally powered from internal batteries. This is a 4.8V NiMH battery pack.

However, the batteries can be charged or the terminal can be operated using an external power supply (Ault type PW 107) or a 12Vdc car adapter.

### 3.3. EUT'S TECHNICAL SPECIFICATIONS

TRANSMITTER	
Equipment Type:	[x] Portable/Handheld
Intended Operating Environment:	[ x ] Commercial [ x ] Light Industry & Heavy Industry
Power Supply Requirement:	4.8 Vdc
RF Output Power Rating:	33.2 dBm (2.1 W maximum)
Operating Frequency Range:	806-821 MHz 821-824 MHz
RF Output Impedance:	50 Ohms
Channel Spacing:	12.5 & 25 kHz
Duty Cycle:	30% maximum
Modulation Type:	Frequency Modulation (FM)
Emission Designation:	<ul style="list-style-type: none"> <li>• 20K0F1D</li> <li>• 12K6F1D</li> </ul>
Antenna Connector Type:	Extendable with quarter wavelength helical over Quarter wavelength whip
Antenna Description:	Manufacturer: Ace Technologies Type: Extendable with quarter wavelength helical over Quarter wavelength whip Model: MAX-1000 Frequency Range: 824-894 MHz In/Out Impedance: 50 Ohms Gain (dBi): 2±1 (extended) or -1±1 (Retracted) Connector Type: Thread

### 3.4. LIST OF EUT'S PORTS

Port Number	EUT's Port Description	Number of Identical Ports	Connector Type	Cable Type (Shielded/Non-shielded)
1	Ethernet	1	RJ11	Non-shielded
1	RS232	1	26-way-D type	Shielded

### 3.5. ANCILLARY EQUIPMENT

The radio device was connected to the following ancillary/peripheral equipment necessary to exercise the functions and features of the EUT.

1. Toshiba Laptop, Model 1605CDS/4.3, SN: 1027387C4

## EXHIBIT 4. EUT OPERATING CONDITIONS AND CONFIGURATIONS DURING TESTS

### 4.1. CLIMATE TEST CONDITIONS

The climate conditions of the test environment are as follows:

Temperature:	21°C
Humidity:	51%
Pressure:	102 kPa
Power Input Source:	4.8 Vdc

### 4.2. OPERATIONAL TEST CONDITIONS & ARRANGEMENT FOR TEST SIGNALS

<b>Operating Modes:</b>	The transmitter was operated in a continuous transmission mode with the carrier modulated as specified in the Test Data.
<b>Special Test Software:</b>	Test software provided by Keycorp Limited.to configured the EUT for different test modes
<b>Special Hardware Used:</b>	N/A
<b>Transmitter Test Antenna:</b>	The EUT is tested with the antenna fitted in a manner typical of normal intended use.

<b>Transmitter Test Signals</b>	
Frequency Band(s): <ul style="list-style-type: none"> <li>▪ 806-821 MHz</li> <li>▪ 821-824 MHz:</li> </ul>	Lowest, middle and highest channel frequencies tested: 806 MHz, 813.5 MHz and 821 MHz 821 MHz, 822.5 MHz and 824 MHz
Transmitter Wanted Output Test Signals: <ul style="list-style-type: none"> <li>▪ RF Power Output (measured maximum output power):</li> <li>▪ Normal Test Modulation:</li> <li>▪ Modulating Signal Source:</li> </ul>	33.18 dBm (2.1 Watts) Conducted 4-Level FSK Internal random data

## EXHIBIT 5. SUMMARY OF TEST RESULTS

### 5.1. LOCATION OF TESTS

All of the measurements described in this report were performed at Ultratech Group of Labs located in the city of Oakville, Province of Ontario, Canada.

Radiated Emissions were performed at the Ultratech's 3 Meter Open Field Test Site (OFTS) situated in the Town of Oakville, province of Ontario.

The above site have been calibrated in accordance with ANSI C63.4, and found to be in compliance with the requirements of Sec. 2.948 of the FCC Rules. The descriptions and site measurement data of the Oakville Open Field Test Site has been filed with FCC office (FCC File No.: 31040/SIT 1300B3) and Industry Canada office (Industry Canada File No.: IC2049). Last Date of Site Calibration: August 10, 2002.

### 5.2. APPLICABILITY & SUMMARY OF EMC EMISSION TEST RESULTS

FCC 47 CFR Section(s)	Test Requirements	Applicability (Yes/No)
90.205 & 2.1046	RF Power Output	Yes
1.1307, 1.1310, 2.1091 & 2.1093	RF Exposure Limit	Yes
90.213 & 2.1055	Frequency Stability	See original filing test report
90.242(b)(8) & 2.1047(a)	Audio Frequency Response	Not applicable
90.210 & 2.1047(b)	Modulation Limiting	Not applicable
90.210 & 2.1049	Emission Limitation & Emission Mask	Yes
90.210, 2.1057 & 2.1051	Emission Limits - Spurious Emissions at Antenna Terminal	See original filing test report
90.210, 2.1057 & 2.1053	Emission Limits - Field Strength of Spurious Emissions	Yes

### 5.3. MODIFICATIONS INCORPORATED IN THE EUT FOR COMPLIANCE PURPOSES

None.

## **EXHIBIT 6. MEASUREMENTS, EXAMINATIONS & TEST DATA FOR EMC EMISSIONS**

### **6.1. TEST PROCEDURES**

This section contains test results only. Details of test methods and procedures can be found in Exhibit 7 of this report.

### **6.2. MEASUREMENT UNCERTAINTIES**

The measurement uncertainties stated were calculated in accordance with requirements of UKAS Document NIS 81 with a confidence level of 95%. Please refer to Exhibit 6 for Measurement Uncertainties.

### **6.3. MEASUREMENT EQUIPMENT USED**

The measurement equipment used complied with the requirements of the Standards referenced in the Methods & Procedures ANSI C63.4:1992 and CISPR 16-1.

### **6.4. ESSENTIAL/PRIMARY FUNCTIONS AS DECLARED BY THE MANUFACTURER**

The essential function of the EUT is to correctly communicate data to and from radios over RF link.

## 6.5. RF POWER OUTPUT @ FCC 2.1046 & 90.205

### 6.5.1. Limits @ FCC 90.205

Please refer to FCC 47 CFR, Part 90, Subpart I, Section 90.205 for specification details.

### 6.5.2. Method of Measurements

Please refer to Exhibit 8, section 8.1 (Conducted) and section 8.2 (Radiated) for test procedures and test setup.

### 6.5.3. Test Equipment List

Test Instruments	Manufacturer	Model No.	Serial No.	Frequency Range
Attenuator	Weinschel Corp	24-20-34	BK-2804	DC – 8.5 GHz
Spectrum Analyzer	Rohde Schwarz	FSEK20/B4/B21	834157/005	9 kHz – 40 GHz

### 6.5.4. Test Arrangement

Conducted Output Power at Antenna Terminals:

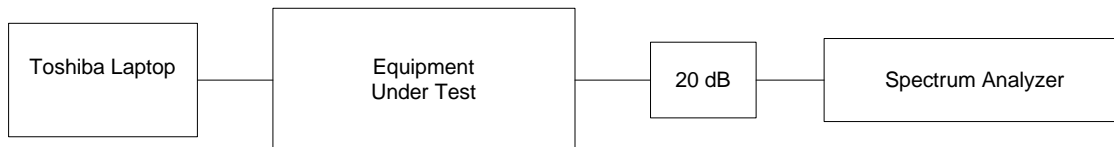

### 6.5.5. Test Data

Conducted Output Power at Antenna Terminals:

Transmitter Channel Output	Fundamental Frequency (MHz)	Measured Power (dBm)	Power Rating (dBm)
Lowest	806	33.03	33.0
Middle	815	33.05	33.0
Highest	824	33.18	33.0

## 6.6. EMISSION MASK @ FCC 2.1049, 90.208 & 90.210

### 6.6.1. Limits @ FCC 90.209 & 90.210

Emissions shall be attenuated below the mean output power of the transmitter as follows:

Frequency Range (MHz)	Maximum Authorized BW (kHz)	Channel Spacing (kHz)	Recommended Max. Frequency Deviation (kHz)	FCC Applicable Mask
806-821	20	25	5	MASK G (Data)
821-824	20	12.5	2.5	MASK H (Data)

### 6.6.2. Method of Measurements

Refer to Exhibit 8, § 8.2 of this report for measurement details

### 6.6.3. Test Equipment List

Test Instruments	Manufacturer	Model No.	Serial No.	Frequency Range
Attenuator	Weinschel Corp	24-20-34	BK-2804	DC – 8.5 GHz
Spectrum Analyzer/EMI Receiver	Hewlett Packard	HP 8593EM	3412A00103	9 kHz – 26.5 GHz
Spectrum Analyzer	Rohde Schwarz	FSEK20/B4/B21	834157/005	9 kHz – 40 GHz
Audio Oscillator	Hewlett Packard	HP 204C	0989A08798	DC to 1.2 MHz

### 6.6.4. Test Arrangement

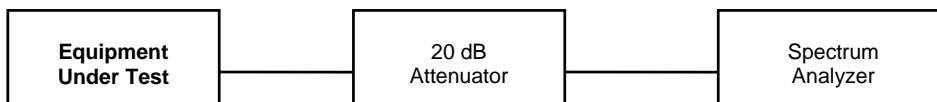

## 6.6.5. Test Data

### 6.6.5.1. 99% Occupied Bandwidth – 25 kHz Channel Spacing 806-821

Frequency (MHz)	Emission Designation	Measured 99% OBW (kHz)	Recommended Max. 99% OBW (kHz)	Refer to Plot Number
806.0	20K0F1D	16.4	20	1
813.5	20K0F1D	16.7	20	2
821.0	20K0F1D	17.0	20	3

### 6.6.5.2. 99% Occupied Bandwidth – 12.5 kHz Channel Spacing 821-824 MHz

Frequency (MHz)	Emission Designation	Measured 99% OBW (kHz)	Recommended Max. 99% OBW (kHz)	Refer to Plot Number
821.0	12K6F1D	11.4	20	4
822.5	12K6F1D	11.6	20	5
824.0	12K6F1D	11.6	20	6

Please refer to Plot 1 to 6 for detailed measurements.



**Plot # 1: 99% Occupied Bandwidth at 806 MHz in FCC Permitted 806 – 821 MHz Band**  
**Modulation:** Random data, 4-Level FSK RDLAP 19.2, 5.6kHz deviation

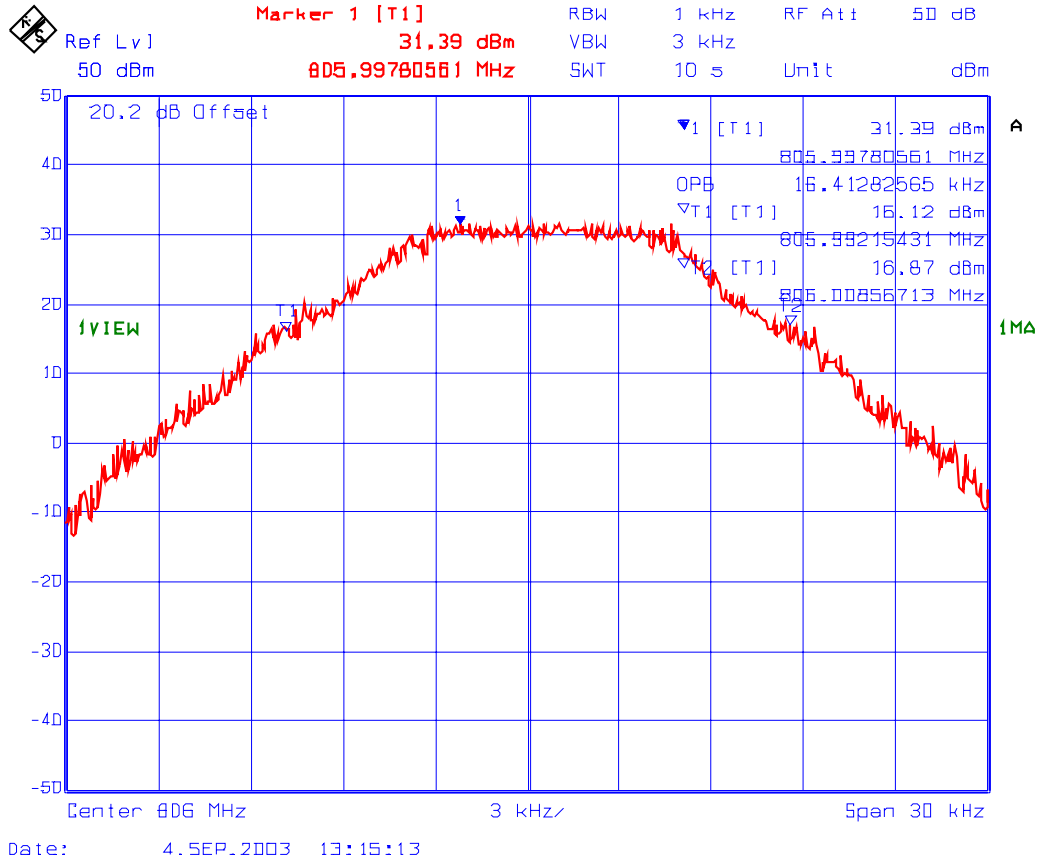

**Plot # 2: 99% Occupied Bandwidth at 813.5 MHz in FCC Permitted 806 – 821 MHz Band**

**Modulation:** Random data, 4-Level FSK RDLAP 19.2, 5.6kHz deviation

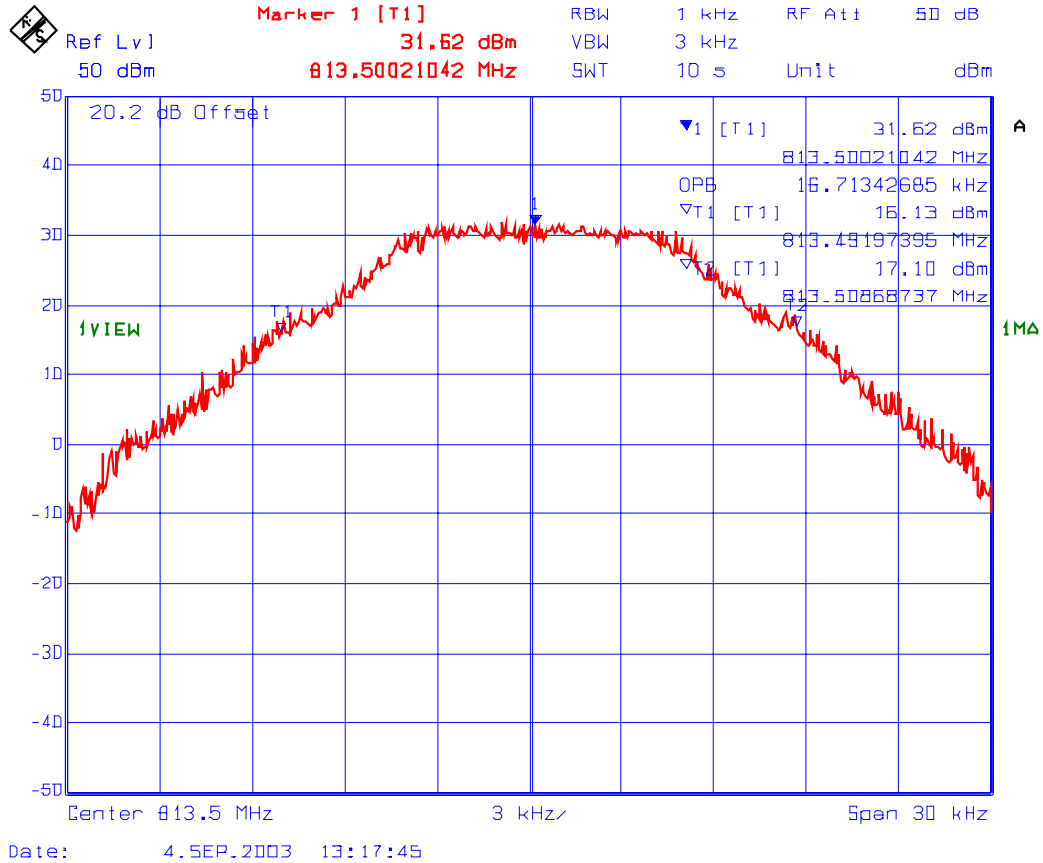

**Plot # 3: 99% Occupied Bandwidth at 821 MHz in FCC Permitted 806 – 821 MHz Band**  
**Modulation:** Random data, 4-Level FSK RDLAP 19.2, 5.6kHz deviation

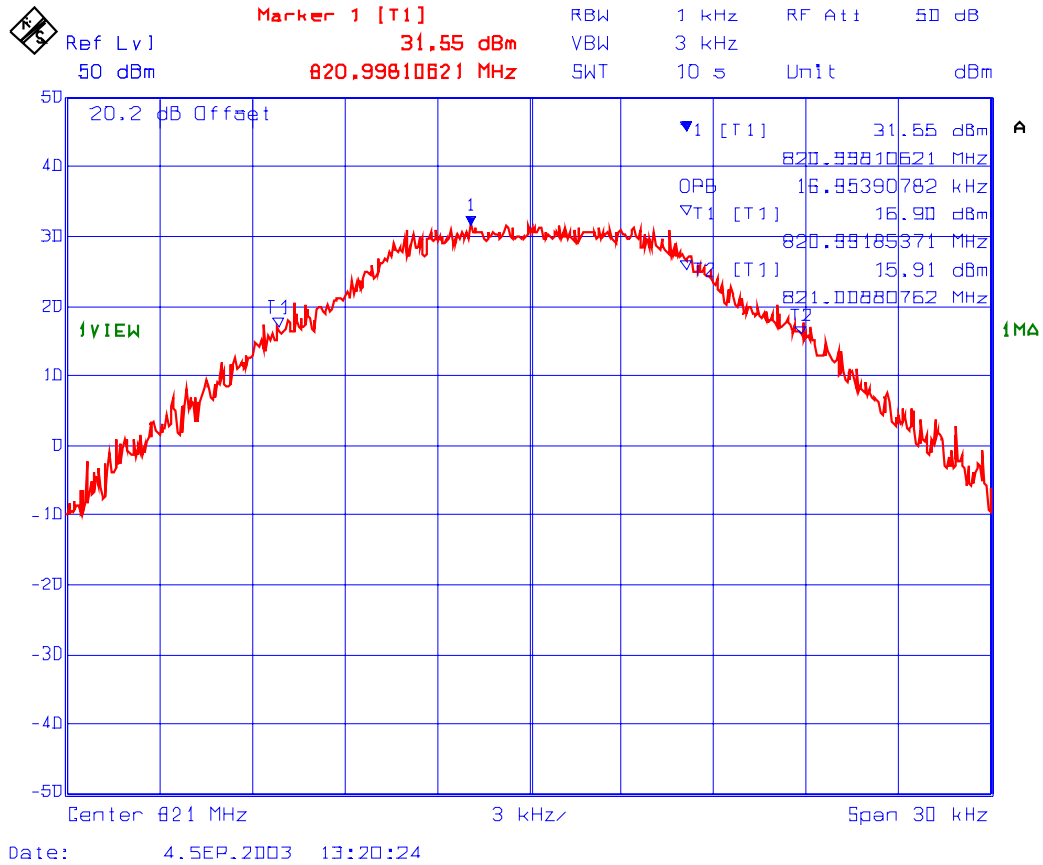

**Plot # 4: 99% Occupied Bandwidth at 821 MHz in FCC Permitted 821 – 824 MHz Band**

**Modulation:** Random data, 4-Level FSK RDLAP 19.2, 5.6kHz deviation

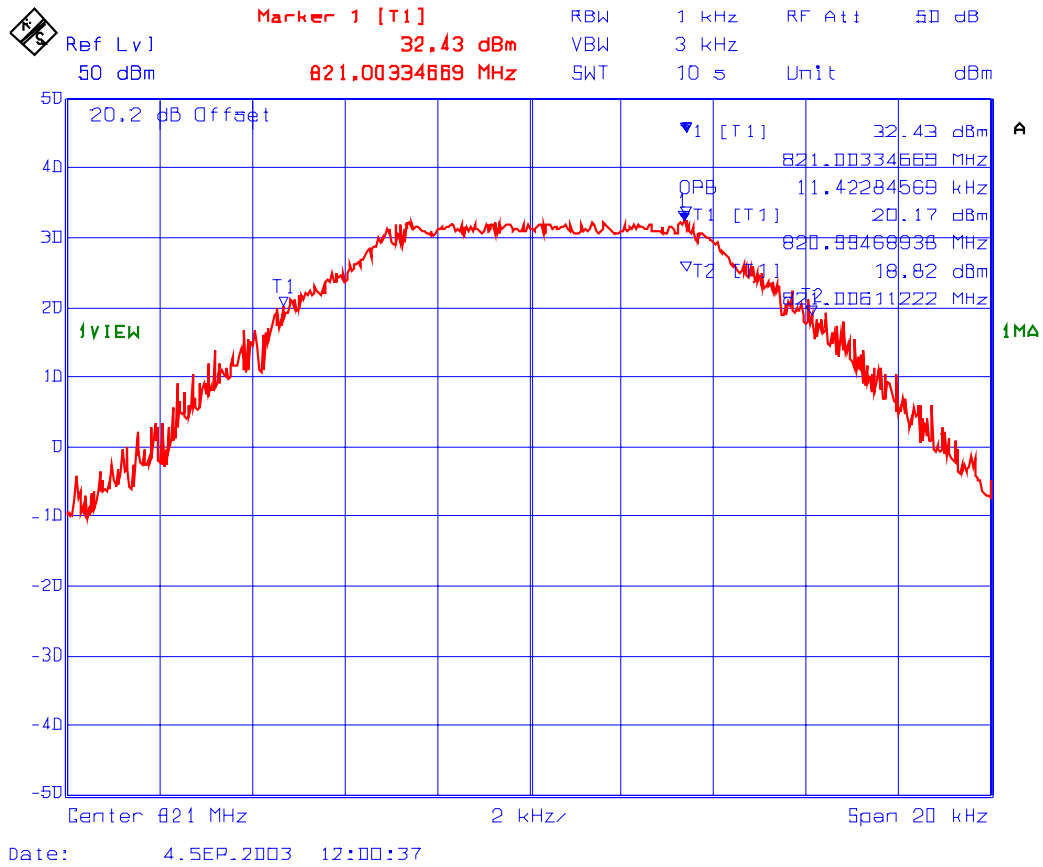

**Plot # 5: 99% Occupied Bandwidth at 822.5 MHz in FCC Permitted 821 – 824 MHz Band**

**Modulation:** Random data, 4-Level FSK RDLAP 19.2, 5.6kHz deviation

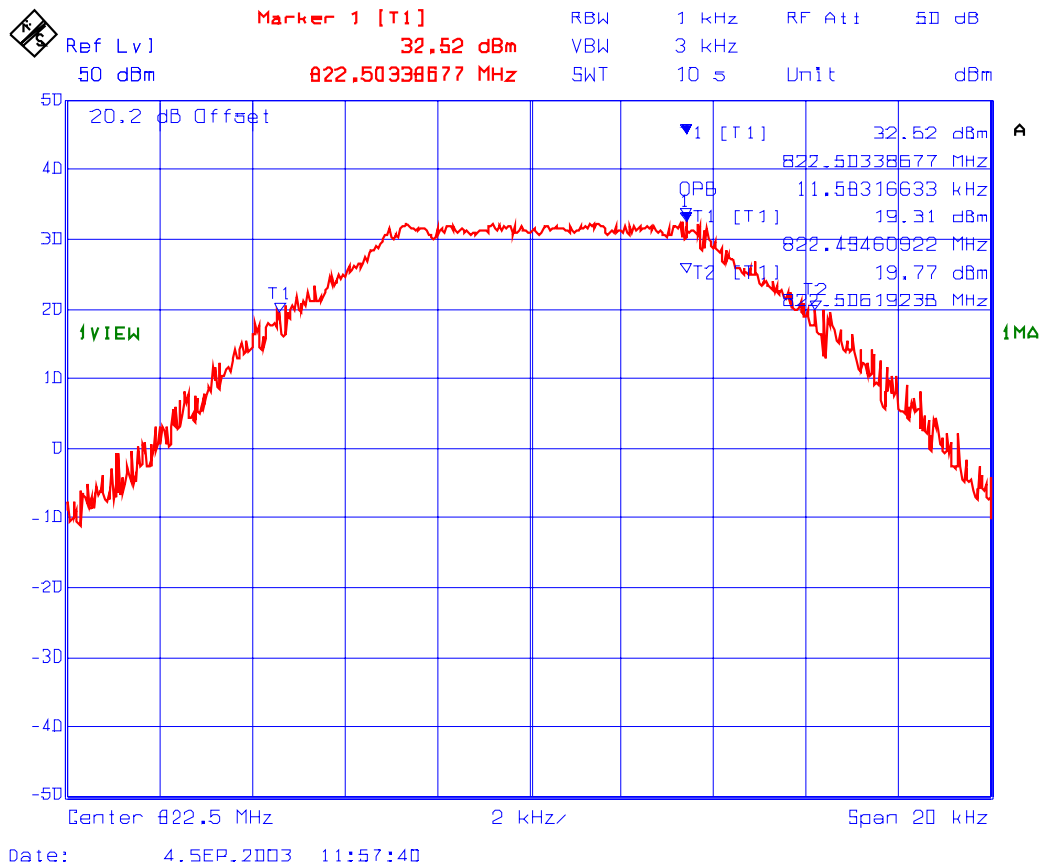

**Plot # 6: 99% Occupied Bandwidth at 824 MHz in FCC Permitted 821 – 824 MHz Band**

**Modulation:** Random data, 4-Level FSK RDLAP 19.2, 5.6kHz deviation

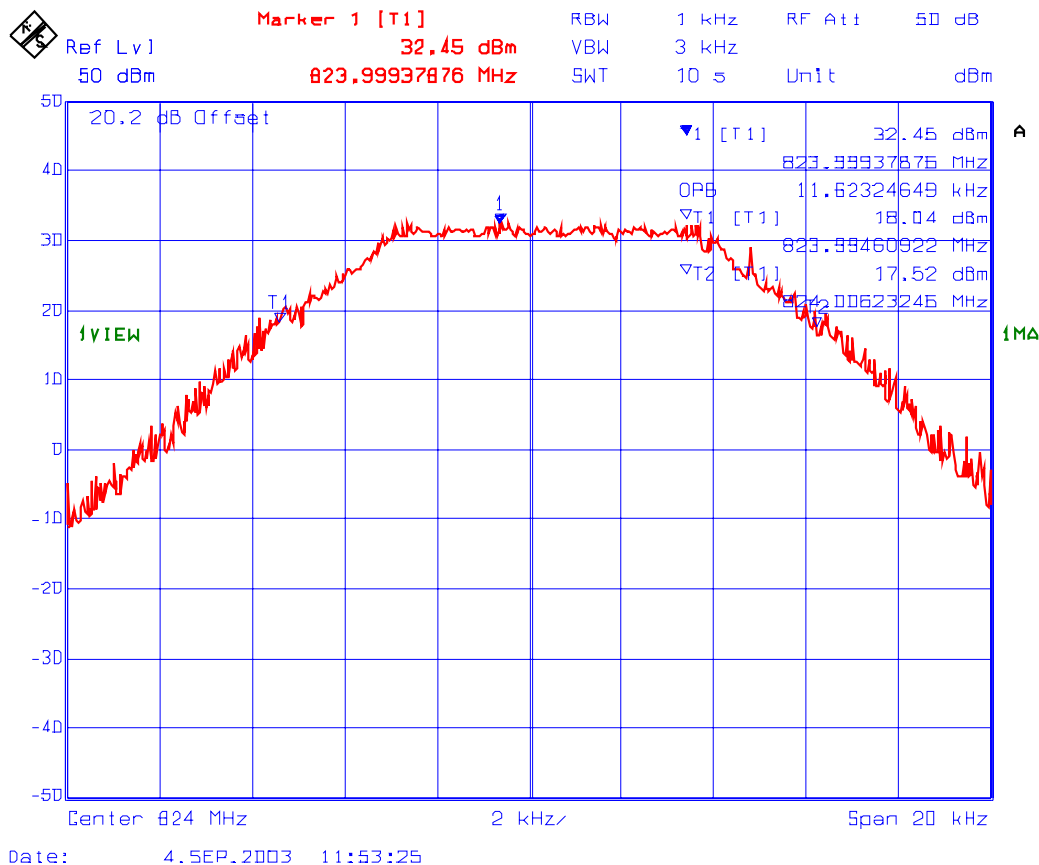

### **6.6.5.3. Emission Masks**

Conform.

- Emission Mask G for FM Data Modulation, Permitted Band 806-821 MHz, 25 kHz Channel Spacing, setting: refer to Plots # 7 to 9
- Emission Mask H for FM Data Modulation, Permitted Band 821-824 MHz, 12.5 kHz Channel Spacing, setting: refer to Plots # 10 to 12

**Plot # 7: Emission Mask G - Low 806 MHz in FCC Permitted 806 – 821 MHz Band**  
**Modulation:** Random data, 4-Level FSK RDLAP 19.2, 5.6kHz deviation

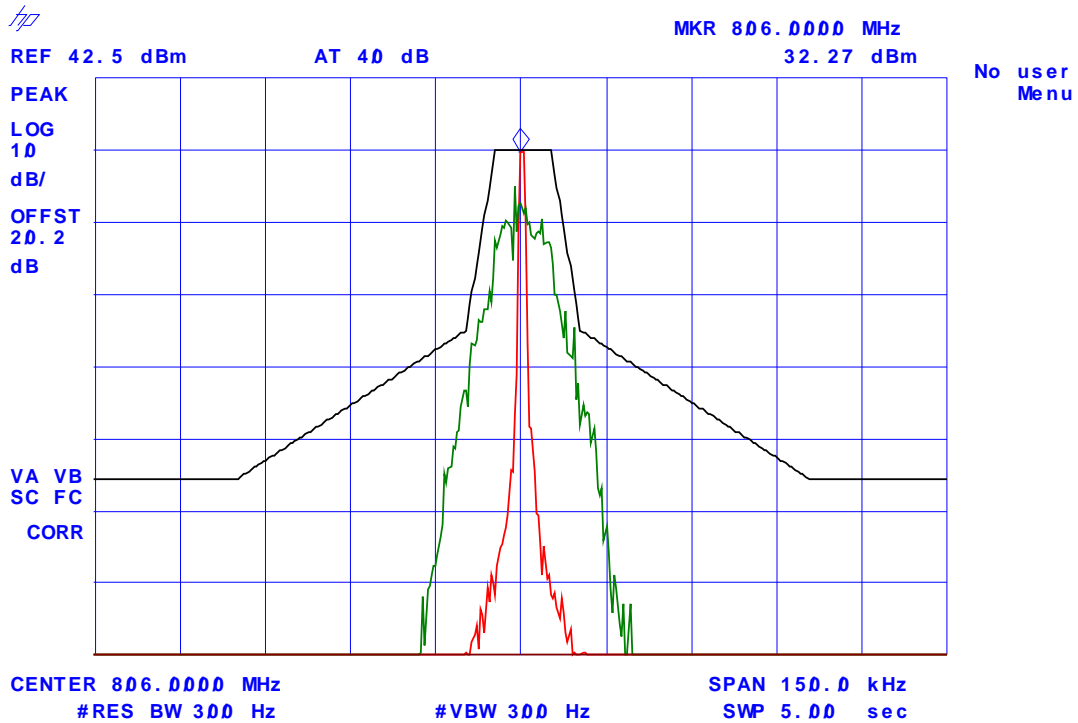



**Plot # 8: Emission Mask G - Middle 813.5 MHz in FCC Permitted 806 – 821 MHz Band**  
**Modulation:** Random data, 4-Level FSK RDLAP 19.2, 5.6kHz deviation

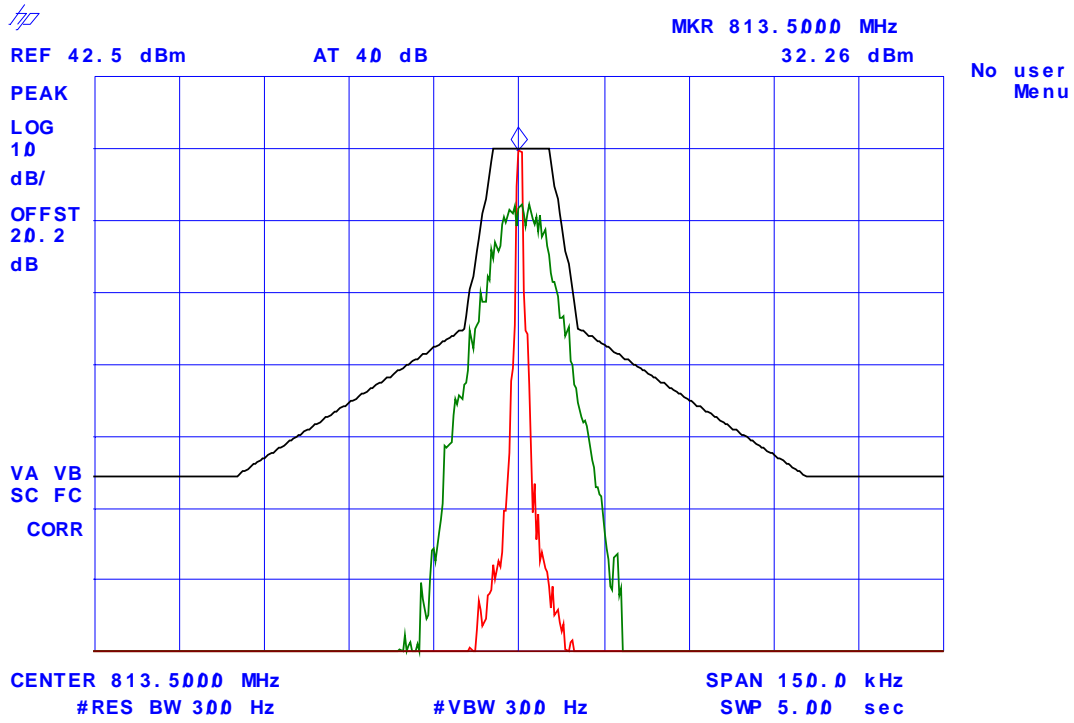

**Plot # 9: Emission Mask G - High 821 MHz in FCC Permitted 806 – 821 MHz Band**  
**Modulation:** Random data, 4-Level FSK RDLAP 19.2, 5.6kHz deviation

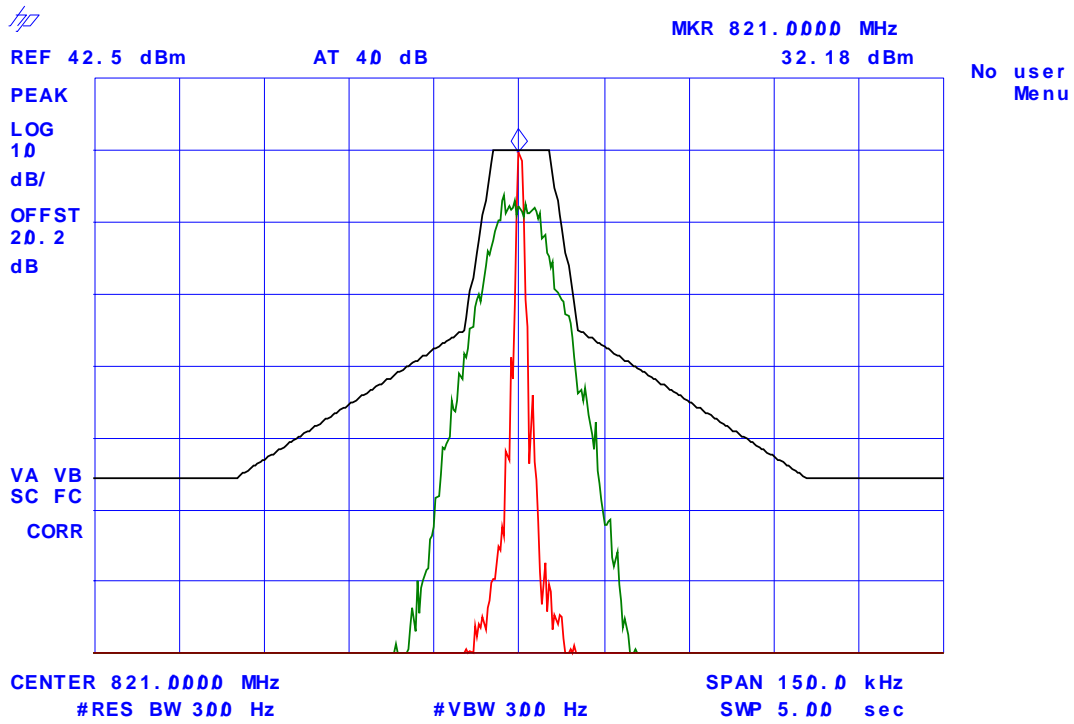

**Plot # 10: Emission Mask H - Low 821 MHz in FCC Permitted 821 – 824 MHz Band**  
**Modulation:** Random data, 4-Level FSK RDLAP 19.2, 5.6kHz deviation

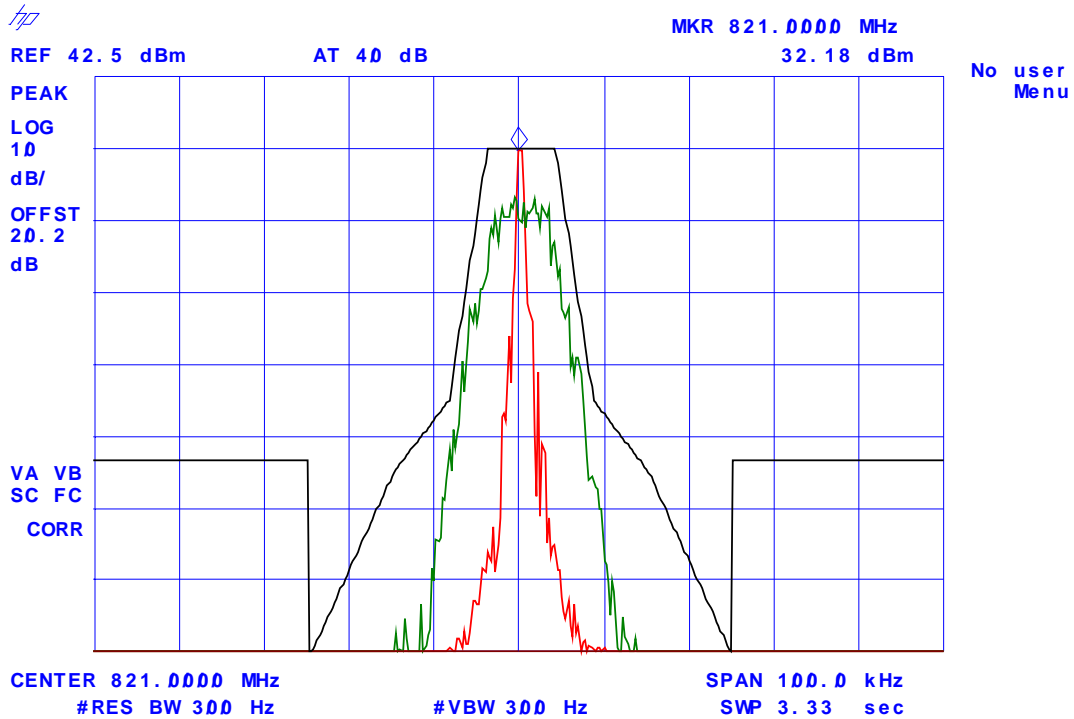

**Plot # 11: Emission Mask H - Middle 822.5 MHz in FCC Permitted 821 – 824 MHz Band**  
**Modulation:** Random data, 4-Level FSK RDLAP 19.2, 5.6kHz deviation

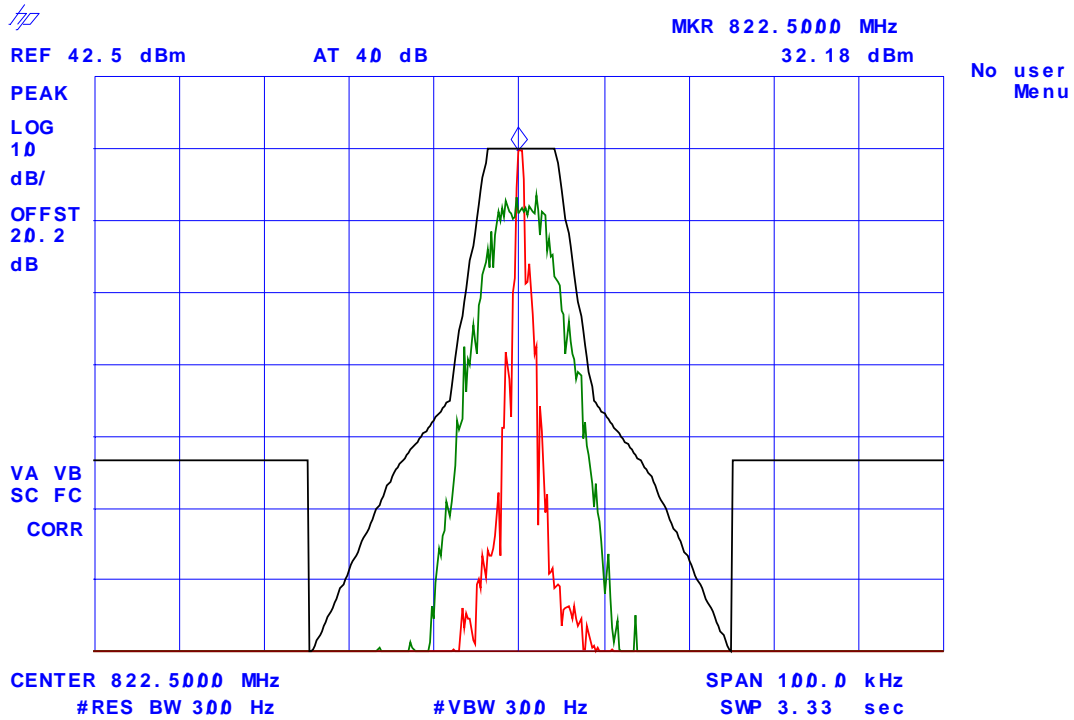

**Plot # 12: Emission Mask H - High 824 MHz in FCC Permitted 821 – 824 MHz Band**  
**Modulation:** Random data, 4-Level FSK RDLAP 19.2, 5.6kHz deviation

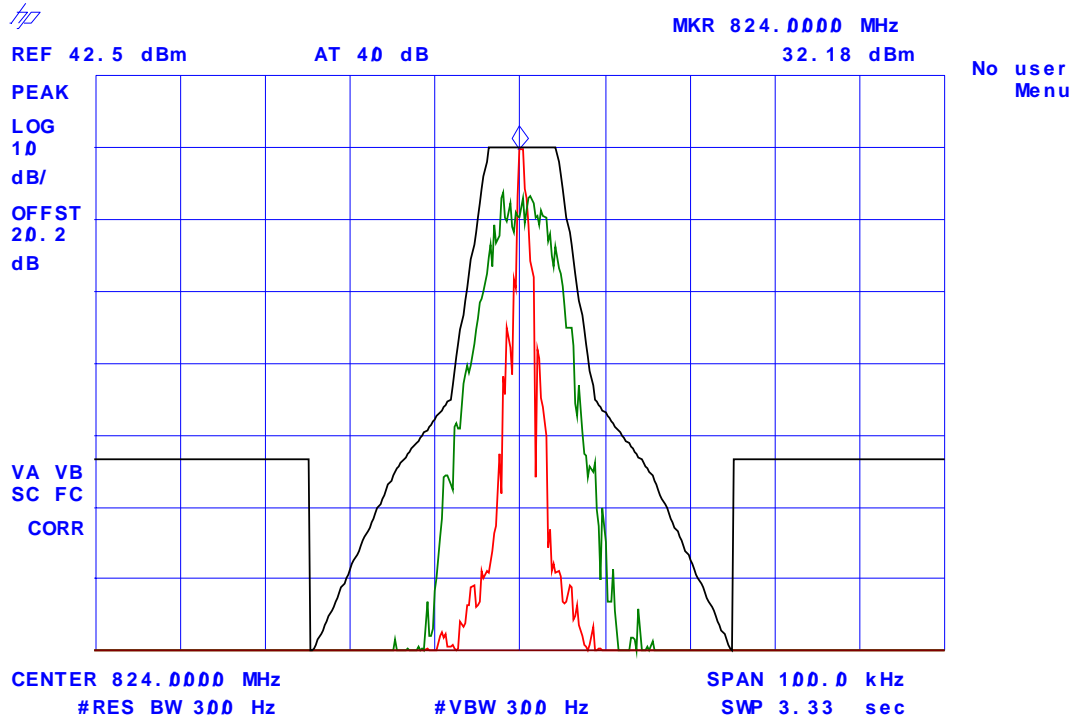

## 6.7. FIELD STRENGTH OF SPURIOUS RADIATION @ FCC 2.1053 & 90.210

### 6.7.1. Limits @ FCC 90.210

Emissions shall be attenuated below the mean output power of the transmitter as follows:

FCC Rules	Worst Case Emissions Limit	Attenuation Limit (dBc)
FCC 90.210(g)	FCC 90.210 (g)	43 + 10 log (P), P is output power in watts

### 6.7.2. Method of Measurements

The spurious/harmonic ERP measurements, using substitution method specified in Exhibit 8, section 8.1 of this report and its value in dBc is calculated as follows:

If the transmitter's antenna is an integral part of the EUT, the ERP is measured using substitution method.

If the transmitter's antenna is non-integral and diverse, the lowest ERP of the carrier with 0 dBi antenna gain is used for calculation of the spurious/harmonic emissions in dBc:

Lowest ERP of the carrier = EIRP – 2.15 dB = P<sub>c</sub> + G - 2.15 dB = xxx dBm (conducted) + 0 dBi – 2.15 dB  
 Spurious /harmonic emissions levels expressed in dBc (dB below carrier) are as follows:

ERP of spurious/harmonic (dBc) = ERP of carrier (dBm) – ERP of spurious/harmonic emission (dBm)

### 6.7.3. Test Equipment List

Test Instruments	Manufacturer	Model No.	Serial No.	Frequency Range
Spectrum Analyzer/ EMI Receiver	Hewlett Packard	HP 8546A	...	9 kHz to 5.6 GHz with built-in 30 dB Gain Pre-selector, QP, Average & Peak Detectors.
RF Amplifier	Com-Power	PA-102		1 MHz to 1 GHz, 30 dB gain nominal
Microwave Amplifier	Hewlett Packard	HP 83017A		1 GHz to 26.5 GHz, 30 dB nominal
Biconilog Antenna	EMCO	3142	10005	30 MHz to 2 GHz
Dipole Antenna	EMCO	3121C	8907-434	30 GHz – 1 GHz
Dipole Antenna	EMCO	3121C	8907-440	30 GHz – 1 GHz
Horn Antenna	EMCO	3155	9701-5061	1 GHz – 18 GHz
Horn Antenna	EMCO	3155	9911-5955	1 GHz – 18 GHz
RF Signal Generator	Hewlett Packard	HP 83752B	3610A00457	0.01 – 20 GHz

## 6.7.4. Test Data

### 6.7.4.1. Near Lowest Frequency (806 MHz)

Fundamental Frequency:	806 MHz
RF Output Power:	33.03 dBm
Limit:	46.03 dBc
Modulation:	4-Level FSK RDLAP 19.2, 5.6kHz deviation
The emissions were scanned from 10 MHz to 10 GHz and no significant emissions were found. All emissions were more than 20 dB below the limit.	

### 6.7.4.2. Near Middle Frequency (813.5 MHz)

Fundamental Frequency:	815 MHz
RF Output Power:	33.05 dBm
Limit:	46.05 dBc
Modulation:	4-Level FSK RDLAP 19.2, 5.6kHz deviation
The emissions were scanned from 10 MHz to 10 GHz and no significant emissions were found. All emissions were more than 20 dB below the limit.	

### 6.7.4.3. Near Highest Frequency (821 MHz)

Fundamental Frequency:	824MHz
RF Output Power:	33.18 dBm
Limit:	46.18 dBc
Modulation:	4-Level FSK RDLAP 19.2, 5.6kHz deviation
The emissions were scanned from 10 MHz to 10 GHz and no significant emissions were found. All emissions were more than 20 dB below the limit.	

## EXHIBIT 7. MEASUREMENT UNCERTAINTY

The measurement uncertainties stated were calculated in accordance with the requirements of NIST Technical Note 1297 and NIS 81 (1994)

### 7.1. RADIATED EMISSION MEASUREMENT UNCERTAINTY

CONTRIBUTION (Radiated Emissions)	PROBABILITY DISTRIBUTION	UNCERTAINTY ( $\pm$ dB)	
		3 m	10 m
Antenna Factor Calibration	Normal (k=2)	$\pm 1.0$	$\pm 1.0$
Cable Loss Calibration	Normal (k=2)	$\pm 0.3$	$\pm 0.5$
EMI Receiver specification	Rectangular	$\pm 1.5$	$\pm 1.5$
Antenna Directivit	Rectangular	+0.5	+0.5
Antenna factor variation with height	Rectangular	$\pm 2.0$	$\pm 0.5$
Antenna phase center variation	Rectangular	0.0	$\pm 0.2$
Antenna factor frequency interpolation	Rectangular	$\pm 0.25$	$\pm 0.25$
Measurement distance variation	Rectangular	$\pm 0.6$	$\pm 0.4$
Site imperfections	Rectangular	$\pm 2.0$	$\pm 2.0$
Mismatch: Receiver VRC $\Gamma_1 = 0.2$ Antenna VRC $\Gamma_R = 0.67$ (Bi) 0.3 (Lp) Uncertainty limits $20\text{Log}(1 \pm \Gamma_1 \Gamma_R)$	U-Shaped	+1.1 -1.25	$\pm 0.5$
System repeatability	Std. Deviation	$\pm 0.5$	$\pm 0.5$
Repeatability of EUT		-	-
Combined standard uncertainty	Normal	+2.19 / -2.21	+1.74 / -1.72
Expanded uncertainty U	Normal (k=2)	+4.38 / -4.42	+3.48 / -3.44

Calculation for maximum uncertainty when 3m biconical antenna including a factor of k = 2 is used:

$$U = 2u_c(y) = 2x(+2.19) = +4.38 \text{ dB} \quad \text{And} \quad U = 2u_c(y) = 2x(-2.21) = -4.42 \text{ dB}$$



## EXHIBIT 8. MEASUREMENT METHODS

### 8.1. RADIATED POWER MEASUREMENTS (ERP & EIRP) USING SUBSTITUTION

#### 8.1.1. Maximizing RF Emission Level (E-Field)

- (a) The measurements were performed with full rf output power and modulation.
- (b) Test was performed at listed 3m open area test site (listed with FCC, IC, ITI, NVLAP, ACA & VCCI).
- (c) The transmitter under test was placed at the specified height on a non-conducting turntable (80 cm height)
- (d) The BICONILOG antenna (20 MHz to 1 GHz) or HORN antenna (1 GHz to 18 GHz) was used for measuring.
- (e) Load an appropriate correction factors file in EMI Receiver for correcting the field strength reading level
  - ® Total Correction Factor recorded in the EMI Receiver = Cable Loss + Antenna Factor
  - ®  $E \text{ (dBuV/m)} = \text{Reading (dBuV)} + \text{Total Correction Factor (dB/m)}$
- (f) Set the EMI Receiver #1 and #2 as follows:

Center Frequency:	test frequency
Resolution BW:	100 kHz
Video BW:	same
Detector Mode:	positive
Average:	off
Span:	3 x the signal bandwidth

- (g) The test antenna was lowered or raised from 1 to 4 meters until the maximum signal level was detected.
- (h) The transmitter was rotated through  $360^\circ$  about a vertical axis until a higher maximum signal was received.
- (i) The test antenna was lowered or raised again from 1 to 4 meters until a maximum was obtained. This level was recorded.
- (j) The recorded reading was corrected to the true field strength level by adding the antenna factor, cable loss and subtracting the pre-amplifier gain.
- (k) The above steps were repeated with both transmitters' antenna and test receiving antenna placed in vertical and horizontal polarization. Both readings with the antennas placed in vertical and horizontal polarization shall be recorded.
- (l) Repeat for all different test signal frequencies

### 8.1.2. Measuring the EIRP of Spurious/Harmonic Emissions using Substitution Method

- (a) Set the EMI Receiver #1(for measuring E-Field) and Receiver #2 (for measuring EIRP) as follows:

Center Frequency: equal to the signal source  
Resolution BW: 10 kHz  
Video BW: same  
Detector Mode: positive  
Average: off  
Span: 3 x the signal bandwidth

- (b) Load an appropriate correction factors file in EMI Receiver for correcting the field strength reading level  
Ⓡ Total Correction Factor recorded in the EMI Receiver = Cable Loss + Antenna Factor  
Ⓡ  $E \text{ (dBuV/m)} = \text{Reading (dBuV)} + \text{Total Correction Factor (dB/m)}$   
(c) Select the frequency and E-field levels obtained in the Section 8.2.1 for ERP/EIRP measurements.  
(d) Substitute the EUT by a signal generator and one of the following transmitting antenna (substitution antenna):  
Ⓡ DIPOLE antenna for frequency from 30-1000 MHz or  
Ⓡ HORN antenna for frequency above 1 GHz  
(e) Mount the transmitting antenna at 1.5 meter high from the ground plane.  
(f) Use one of the following antenna as a receiving antenna:  
Ⓡ DIPOLE antenna for frequency from 30-1000 MHz or  
Ⓡ HORN antenna for frequency above 1 GHz  
(g) If the DIPOLE antenna is used, tune it's elements to the frequency as specified in the calibration manual.  
(h) Adjust both transmitting and receiving antenna in a VERTICAL polarization.  
(i) Tune the EMI Receivers to the test frequency.  
(j) Lower or raise the test antenna from 1 to 4 meters until the maximum signal level was detected.  
(k) The transmitter was rotated through  $360^\circ$  about a vertical axis until a higher maximum signal was received.  
(l) Lower or raise the test antenna from 1 to 4 meters until the maximum signal level was detected.  
(m) Adjust input signal to the substitution antenna until an equal or a known related level to that detected from the transmitter was obtained in the test receiver.  
(n) Record the power level read from the Average Power Meter and calculates the ERP/EIRP as follows:

$$P = P1 - L1 = (P2 + L2) - L1 = P3 + A + L2 - L1$$
$$\text{EIRP} = P + G1 = P3 + L2 - L1 + A + G1$$
$$\text{ERP} = \text{EIRP} - 2.15 \text{ dB}$$

Total Correction factor in EMI Receiver # 2 =  $L2 - L1 + G1$

Where: P: Actual RF Power fed into the substitution antenna port after corrected.  
P1: Power output from the signal generator  
P2: Power measured at attenuator A input  
P3: Power reading on the Average Power Meter  
EIRP: EIRP after correction  
ERP: ERP after correction

- (o) Adjust both transmitting and receiving antenna in a HORIZONTAL polarization, then repeat step (k) to (o)  
(p) Repeat step (d) to (o) for different test frequency  
(q) Repeat steps (c) to (j) with the substitution antenna oriented in horizontal polarization.  
(r) Actual gain of the EUT's antenna is the difference of the measured EIRP and measured RF power at the RF port. Correct the antenna gain if necessary.

Figure 2

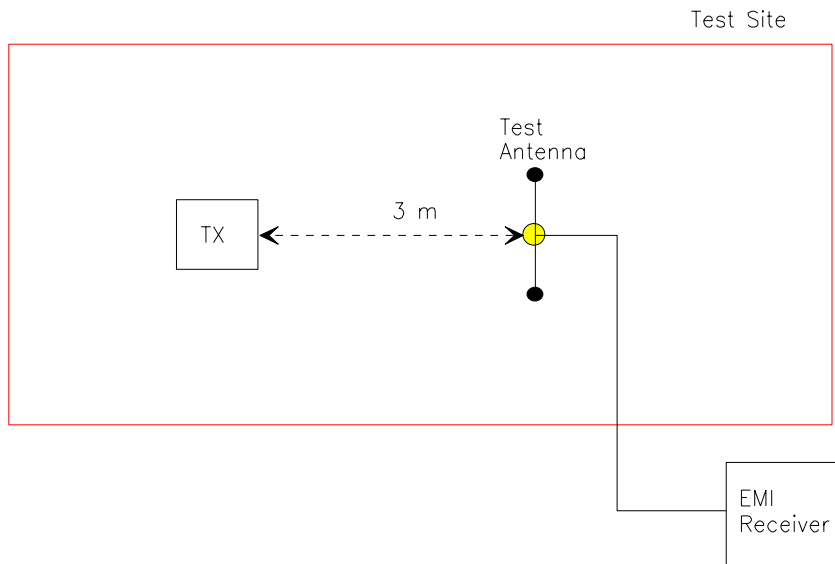
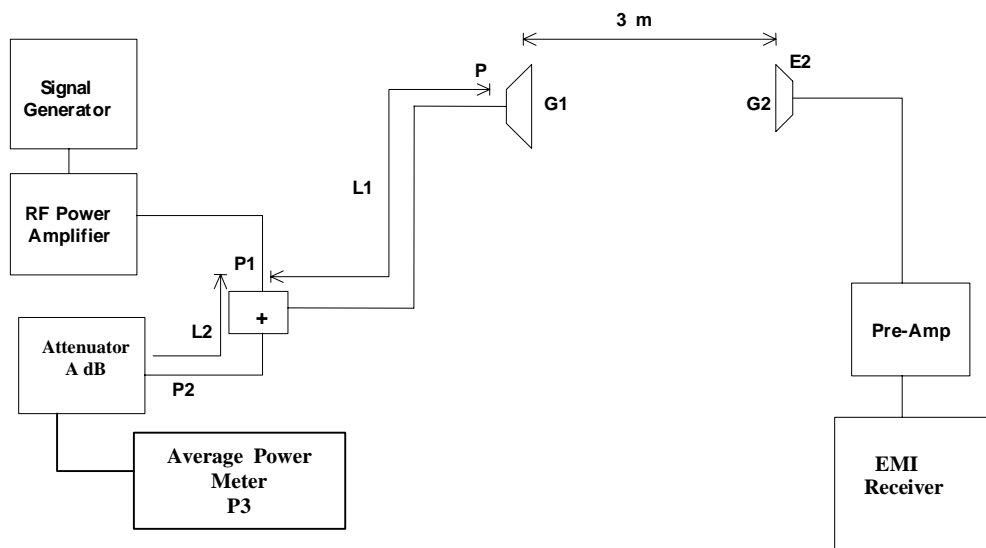

Figure 3



## 8.2. EMISSION MASK

Voice or Digital Modulation Through a Voice Input Port @ 2.1049(c)(i):- The transmitter was modulated by a 2.5 KHz tone signal at an input level 16 dB greater than that required to produce 50% modulation (e.g.:  $\pm 2.5$  KHz peak deviation at 1 KHz modulating frequency). The input level was established at the frequency of maximum response of the audio modulating circuit.

Digital Modulation Through a Data Input Port @ 2.1049(h):- Transmitters employing digital modulation techniques - when modulated by an input signal such that its amplitude and symbol rate represent the maximum rated conditions under which the equipment will be operated. The signal shall be applied through any filter networks, pseudo-random generators or other devices required in normal service. Additionally, the Emission Masks shall be shown for operation with any devices used for modifying the spectrum when such devices are operational at the discretion of the user.

The following EMI Receiver bandwidth shall be used for measurement of Emission Mask/Out-of-Band Emission Measurements:

- (1) For 25 kHz Channel Spacing: RBW = 300 Hz
- (2) For 12.5 kHz or 6.25 kHz Channel Spacings: RBW = 100 Hz

The all cases the Video Bandwidth shall be equal or greater than the measuring bandwidth.