

FCC TEST REPORT

FCC ID : P37AR01AR02
Applicant : UniStrong Science & Technology (USA) Inc.
Address : 2501 E. Chapman Ave., Suite 100, Fullerton, CA 92831.

Equipment Under Test (EUT) :

Product Name : Indoor Bluetooth Speaker
Model No. : AIR01, AIR02

Standards : FCC CFR47 Part 15 Section 15.247:2010

Date of Test : July 25 ~ August 25, 2012

Date of Issue : August 8, 2012

Test Engineer : Zero Zhou / Engineer



Reviewed By : Philo zhong / Manager

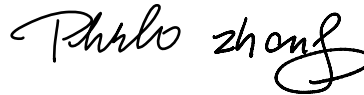

Test Result	: PASS
--------------------	---------------

Prepared By:

Waltek Services (Shenzhen) Co., Ltd.

1/F, Fukangtai Building, West Baima Rd., Songgang Street, Baoan District,
Shenzhen 518105, China

Tel :+86-755-83551033

Fax:+86-755-83552400

✧ The sample detailed above has been tested to the requirements of Council Directives ANSI C63.4:2003. The test results have been reviewed against the Directives above and found to meet their essential requirements.

2 Test Summary

Test Items	Test Requirement	Result
Radiated Spurious Emissions (26MHz to 25GHz)	15.205(a) 15.209 15.247(d)	PASS
20dB Bandwidth	15.247(a)(1)	PASS
Maximum Peak Output Power	15.247(b)(1)	PASS
Frequency Separation	15.247(a)(1)	PASS
Number of Hopping Frequency	15.247(a)(1)(iii)	PASS
Dwell time	15.247(a)(1)(iii)	PASS
Maximum Permissible Exposure (Exposure of Humans to RF Fields)	1.1307(b)(1)	PASS

The results shown in this test report refer only to the sample(s) tested , This Test report cannot be reproduced, except in full, without prior written permission of the Company.

3 Contents

	Page
1 COVER PAGE	1
-	
2 TEST SUMMARY	2
3 CONTENTS	3
4 GENERAL INFORMATION	5
4.1 CLIENT INFORMATION.....	5
4.2 GENERAL DESCRIPTION OF E.U.T.	5
4.3 DETAILS OF E.U.T.....	5
4.4 DESCRIPTION OF SUPPORT UNITS.....	5
4.5 STANDARDS APPLICABLE FOR TESTING	5
4.6 TEST FACILITY	6
4.7 TEST LOCATION	6
5 EQUIPMENT USED DURING TEST	7
6 CONDUCTED EMISSION	9
6.1 E.U.T. OPERATION.....	9
6.2 EUT SETUP.....	10
6.3 CONDUCTED EMISSION TEST RESULT	10
6.4 PHOTOGRAPH – CONDUCTED EMISSION TEST SETUP	13
7 RADIATED SPURIOUS EMISSIONS	14
7.1 EUT OPERATION :	14
7.2 MEASUREMENT UNCERTAINTY	14
7.3 TEST SETUP.....	15
7.4 SPECTRUM ANALYZER SETUP	17
7.5 TEST PROCEDURE.....	18
7.6 CORRECTED AMPLITUDE & MARGIN CALCULATION.....	18
7.7 SUMMARY OF TEST RESULTS	18
7.8 PHOTOGRAPH – RADIATION SPURIOUS EMISSION TEST SETUP.....	32
8 BAND EDGE MEASUREMENTS	34
9 20 DB BANDWIDTH MEASUREMENT	39
9.1 TEST PROCEDURE:.....	39
9.2 TEST RESULT:	39
10 MAXIMUM PEAK OUTPUT POWER	41
10.1 TEST PROCEDURE:.....	41
10.2 TEST RESULT:.....	41
11 HOPPING CHANNEL SEPARATION	42
11.1 TEST PROCEDURE:.....	42
11.2 TEST RESULT:.....	42
12 NUMBER OF HOPPING FREQUENCY	45
12.1 TEST PROCEDURE:.....	45
12.2 TEST RESULT: TOTAL CHANNELS ARE 79 CHANNELS.....	45
13 DWELL TIME	46
13.1 TEST PROCEDURE:.....	46
13.2 TEST RESULT:.....	46
14 ANTENNA REQUIREMENT	53

The results shown in this test report refer only to the sample(s) tested , This Test report cannot be reproduced, except in full, without prior written permission of the Company.

15 RF EXPOSURE 54

15.1 REQUIMENTS: 54

15.2 THE PROCEDURES / LIMIT 54

15.3 MPE CALCULATION METHOD 55

16 PHOTOGRAPHS - CONSTRUCTIONAL DETAILS..... 56

16.1 PRODUCT VIEW 56

16.2 EUT – APPEARANCE VIEW 57

16.3 EUT – OPEN VIEW 61

16.4 EUT – PCB VIEW 61

17 FCC LABEL..... 65

4 General Information

4.1 Client Information

Applicant : UniStrong Science & Technology (USA) Inc.
Address of Applicant : 2501 E. Chapman Ave., Suite 100, Fullerton, CA 92831.

Manufacturer : SHENZHEN DEHUIDA TECHNOLOGY CO., LTD
Address of Manufacturer : Dehuida Industrial Park, No.237, Xikeng Road, Guanlan Street, Baoan District, Shenzhen City.

4.2 General Description of E.U.T.

Product Name : Indoor Bluetooth Speaker
Model No. : AIR01, AIR02
Difference : All models are exactly the same except for different color and appearance.

4.3 Details of E.U.T.

Technical Data : Adapter input: 100 ~ 240VAC, 50/60Hz, 1.1A max
Adapter output: 15.0VDC, 2A
Adapter model: TPA103-30150-US

Operation Frequency : 2402MHz ~ 2480MHz

Antenna Gain : 0 dBi

4.4 Description of Support Units

The EUT has been tested as an independent unit.

4.5 Standards Applicable for Testing

The customer requested FCC tests for a Indoor Bluetooth Speaker. The Rules used were FCC CFR47 Part 15 Section 15.203, Section 15.207, Section 15.209 and Section 15.247.

4.6 Test Facility

The test facility has a test site registered with the following organizations:

- **IC – Registration No.: IC7760A**

Waltek Services(Shenzhen) Co., Ltd. has been registered and fully described in a report filed with the Industry Canada. The acceptance letter from the Industry Canada is maintained in our files. Registration 7760A, July 10, 2012.

- **FCC – Registration No.: 880581**

Waltek Services(Shenzhen) Co., Ltd. EMC Laboratory has been registered and fully described in a report filed with the (FCC) Federal Communications Commission. The acceptance letter from the FCC is maintained in our files. Registration 880581, May 26, 2011.

4.7 Test Location

All the tests were performed at:

Waltek Services(Shenzhen) Co., Ltd. at 1/F, Fukangtai Building, West Baima Rd., Songgang Street, Baoan District, Shenzhen, China

5 Equipment Used during Test

Equipment Name	Manufacturer Model	Equipment No	Internal No	Specification	Cal. Date	Due Date	Uncertainty
EMC Analyzer	Agilent/ E7405A	MY451149 43	W2008001	9k-26.5GHz	Aug. 2, 2012	Aug. 1, 2013	±1dB
Trilog Broadband Antenne	SCHWARZECK MESS-ELEKTROM / VULB9163	336	W2008002	30-3000 MHz	Aug. 2, 2012	Aug. 1, 2013	±1dB
Broad-band Horn Antenna	SCHWARZECK MESS-ELEKTROM / BBHA 9120D(1201)	667	W2008003	1-18GHz	Aug. 2, 2012	Aug. 1, 2013	f < 10 GHz : ±1dB 10GHz < f < 18 GHz : ±1.5dB
Broadband Preamplifier	SCHWARZECK MESS-ELEKTROM / BBV 9718	9718-148	W2008004	0.5-18GHz	Aug. 2, 2012	Aug. 1, 2013	±1.2dB
Broad-band Horn Antenna	SCHWARZECK MESS-ELEKTROM / BBHA 9170	399	W2008005	15-26.5GHz	Aug. 2, 2012	Aug. 1, 2013	±1.5dB
Broadband Preamplifier	SCHWARZECK MESS-ELEKTROM / BBV 9719	9719-254	W2008006	18-26.5GHz	Aug. 2, 2012	Aug. 1, 2013	±1.2dB
10m Coaxial Cable with N-male Connectors	SCHWARZECK MESS-ELEKTROM / AK 9515 H	-	-	-	Aug. 2, 2012	Aug. 1, 2013	-
10m 50 Ohm Coaxial Cable	SCHWARZECK MESS-ELEKTROM / AK 9513	-	-	-	Aug. 2, 2012	Aug. 1, 2013	-
Positioning Controller	C&C LAB/ CC-C-IF	-	-	-	Aug. 2, 2012	Aug. 1, 2013	-
Color Monitor	SUNSPON/ SP-14C	-	-	-	Aug. 2, 2012	Aug. 1, 2013	-
Test Receiver	ROHDE&SCHWARZ/ ESPI	101155	W2005001	9k-3GHz	Aug. 2, 2012	Aug. 1, 2013	±1dB
Two-Line V-Network	ROHDE&SCHWARZ/ ENV216	100115	W2005002	50Ω/50μH	Aug. 2, 2012	Aug. 1, 2013	±10%
RF Generator	TESEQ GmbH/ NSG4070	25781	W2008008	Fraq-range : 9K-1GHz RF voltage : - 60 dBm- +10dBm	Aug. 2, 2012	Aug. 1, 2013	Power_freq distinguish0. 1Hz RFelectricity distinguish 0.1B

The results shown in this test report refer only to the sample(s) tested , This Test report cannot be reproduced, except in full, without prior written permission of the Company.

Equipment Name	Manufacturer Model	Equipment No	Internal No	Specification	Cal. Date	Due Date	Uncertainty
Active Loop Antenna	Beijing Dazhi / ZN30900A	-	-	-	Aug. 2, 2012	Aug. 1, 2013	±1Db
MP3 Player	Ipod Player/A1285	5K85004U3R0	-	-	Aug. 2, 2012	Aug. 1, 2013	±0.5dB

The results shown in this test report refer only to the sample(s) tested , This Test report cannot be reproduced, except in full, without prior written permission of the Company.

6 Conducted Emission

Test Requirement:	FCC CFR 47 Part 15 Section 15.207
Test Method:	ANSI C63.4:2003
Test Result:	PASS
Frequency Range:	150kHz to 30MHz
Class:	Class B
Limit:	66-56 dB μ V between 0.15MHz & 0.5MHz 56 dB μ V between 0.5MHz & 5MHz 60 dB μ V between 5MHz & 30MHz
Detector:	Peak for pre-scan (9kHz Resolution Bandwidth) Quasi-Peak & Average if maximised peak within 6dB of Average Limit

6.1 E.U.T. Operation

Operating Environment:

Temperature: 25.5 °C

Humidity: 51 % RH

Atmospheric Pressure: 1012 mbar

EUT Operation:

The pre-test was performed in normal link mode and connect PC Line in mode, the worse mode is normal link mode, so the data show is that mode's only.

The EUT was tested according to ANSI C63.4:2003. The frequency spectrum from 150kHz to 30MHz was investigated.

The maximised peak emissions from the EUT was scanned and measured for both the Live and Neutral Lines. Quasi-peak & average measurements were performed if peak emissions were within 6dB of the average limit line.

6.2 EUT Setup

The conducted emission tests were performed using the setup accordance with the ANSI C63.4:2003, The specification used in this report was the FCC Part15.207 limits.

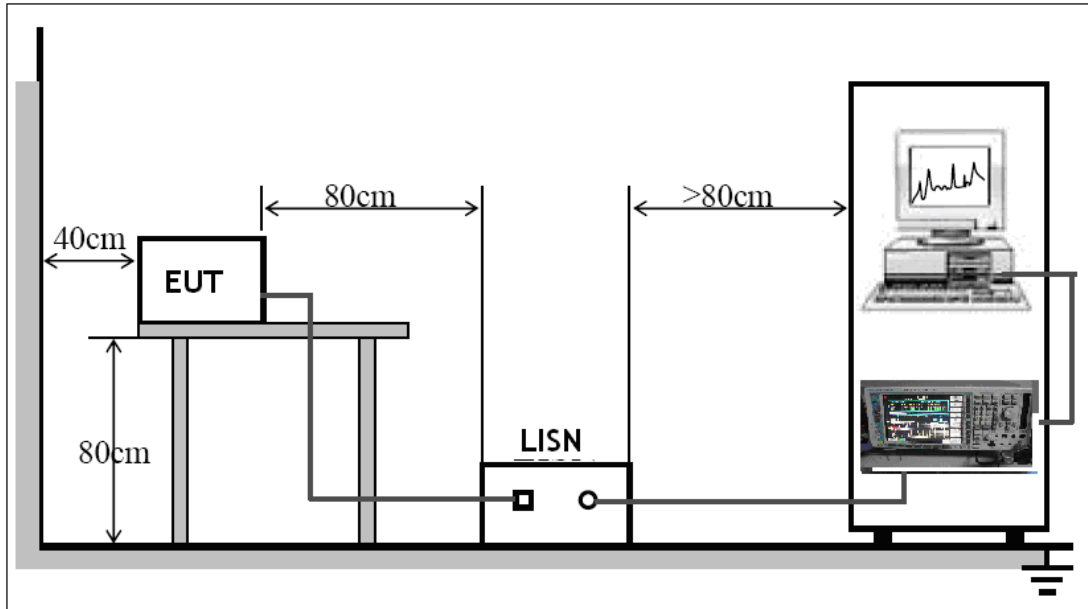

The EUT was placed on the test table in shielding room

6.3 Conducted Emission Test Result

An initial pre-scan was performed on the live and neutral lines.

Live line:

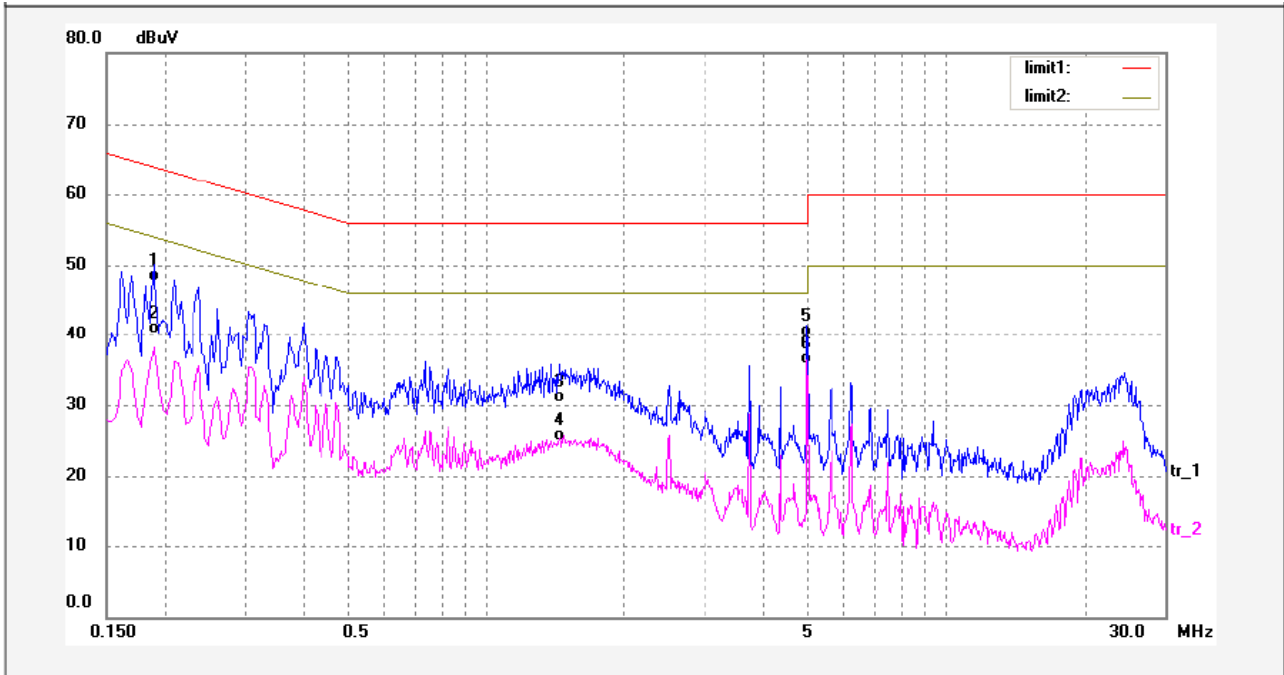

No.	Freq. (MHz)	Reading (dBuV)	Factor (dB)	Result (dBuV)	Limit dBuV	Margin (dB)	Detector	Remark
1	0.1900	37.05	10.67	47.72	64.03	-16.31	QP	
2	0.1900	29.39	10.67	40.06	54.03	-13.97	AVG	
3	1.4420	18.11	12.19	30.30	56.00	-25.70	QP	
4	1.4420	12.79	12.19	24.98	46.00	-21.02	AVG	
5	5.0020	28.02	11.63	39.65	60.00	-20.35	QP	
6	5.0020	24.14	11.63	35.77	50.00	-14.23	AVG	

The results shown in this test report refer only to the sample(s) tested , This Test report cannot be reproduced, except in full, without prior written permission of the Company.

Neutral line:

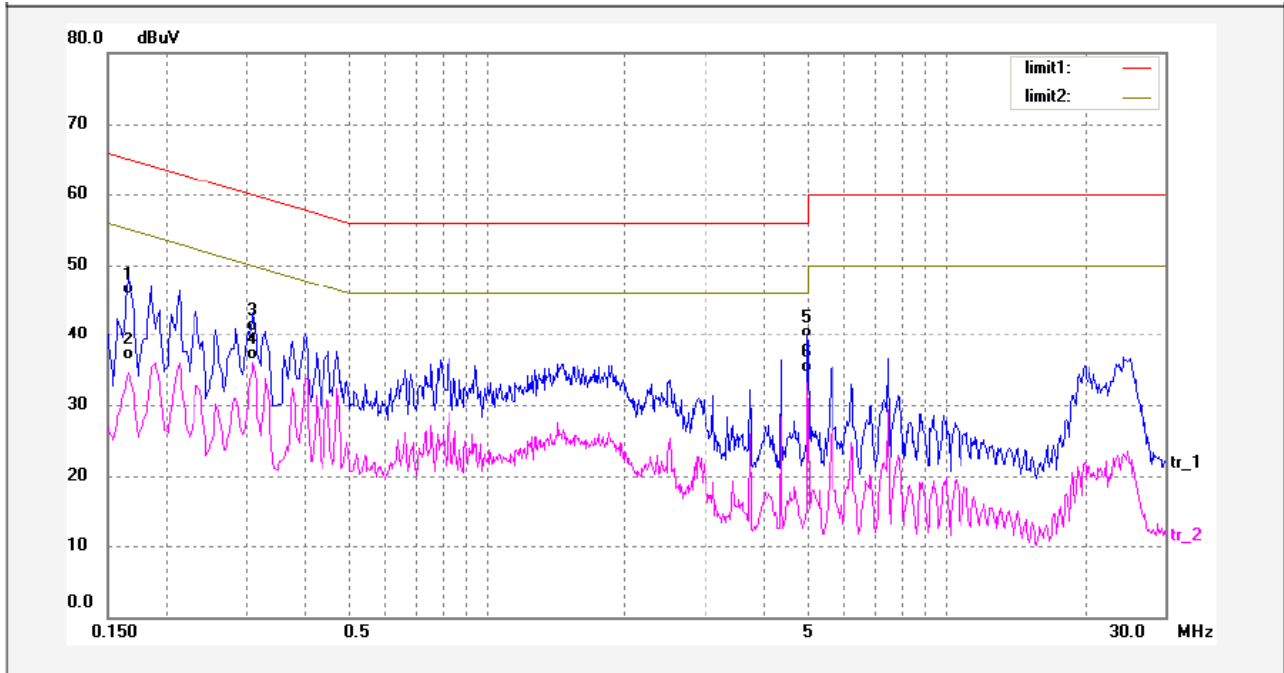

No.	Freq. (MHz)	Reading (dBuV)	Factor (dB)	Result (dBuV)	Limit dBuV	Margin (dB)	Detector	Remark
1	0.1660	35.05	10.65	45.70	65.15	-19.45	QP	
2	0.1660	25.62	10.65	36.27	55.15	-18.88	AVG	
3	0.3100	29.86	10.63	40.49	59.97	-19.48	QP	
4	0.3100	25.76	10.63	36.39	49.97	-13.58	AVG	
5	5.0020	27.86	11.63	39.49	60.00	-20.51	QP	
6	5.0020	22.92	11.63	34.55	50.00	-15.45	AVG	

The results shown in this test report refer only to the sample(s) tested , This Test report cannot be reproduced, except in full, without prior written permission of the Company.

6.4 Photograph – Conducted Emission Test Setup



The results shown in this test report refer only to the sample(s) tested , This Test report cannot be reproduced, except in full, without prior written permission of the Company.

WALTEK SERVICES

Reference No.: WT12075138-S-S-F

7 Radiated Spurious Emissions

Test Requirement:	FCC CFR47 Part 15 Section 15.209 & 15.247
Test Method:	DA 00-705
Test Result:	PASS
Frequency Range:	26MHz to 25GHz
Measurement Distance:	3m
15.209 Limit:	40.0 dBuV/m between 30MHz & 88MHz 43.5 dBuV/m between 88MHz & 216MHz 46.0 dBuV/m between 216MHz & 960MHz 54.0 dBuV/m above 960MHz
15.247 (d) Limit:	(d) In any 100 kHz bandwidth outside the frequency band in which the spread spectrum or digitally modulated intentional radiator is operating. The radio frequency power that is produced by the intentional radiator shall be at least 20 dB below that in the 100 kHz bandwidth within the band that contains the highest level of the desired power, based on either an RF conducted or a radiated measurement, provided the transmitter demonstrates compliance with the peak conducted power limits.
Test mode:	The EUT was tested in continuously Transmit mode.

7.1 EUT Operation :

Operating Environment:

Temperature:	25.5 °C
Humidity:	51 % RH
Atmospheric Pressure:	1012 mbar

7.2 Measurement Uncertainty

All measurements involve certain levels of uncertainties, especially in the field of EMC. The factors contributing to uncertainties are spectrum analyzer, cable loss, antenna factor calibration, antenna directivity, antenna factor variation with height, antenna phase center variation, antenna factor frequency interpolation, measurement distance variation, site imperfections, mismatch (average), and system repeatability.

Based on NIS 81, The Treatment of Uncertainty in EMC Measurements, the best estimate of the uncertainty of a radiation emissions measurement at Waltek EMC Lab is ± 5.03 dB.

7.3 Test Setup

The radiated emission tests were performed in the 3m Semi- Anechoic Chamber test site, using the setup accordance with the ANSI C63.4:2003.

The diagram below shows the test setup that is utilized to make the measurements for emission from 26 MHz to 30 MHz Emissions.

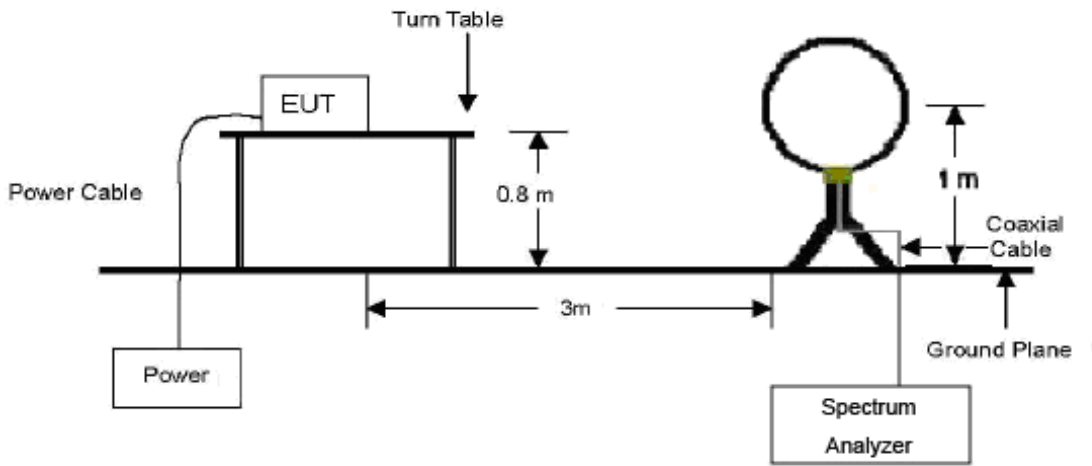

The diagram below shows the test setup that is utilized to make the measurements for emission from 30 MHz to 1 GHz Emissions.

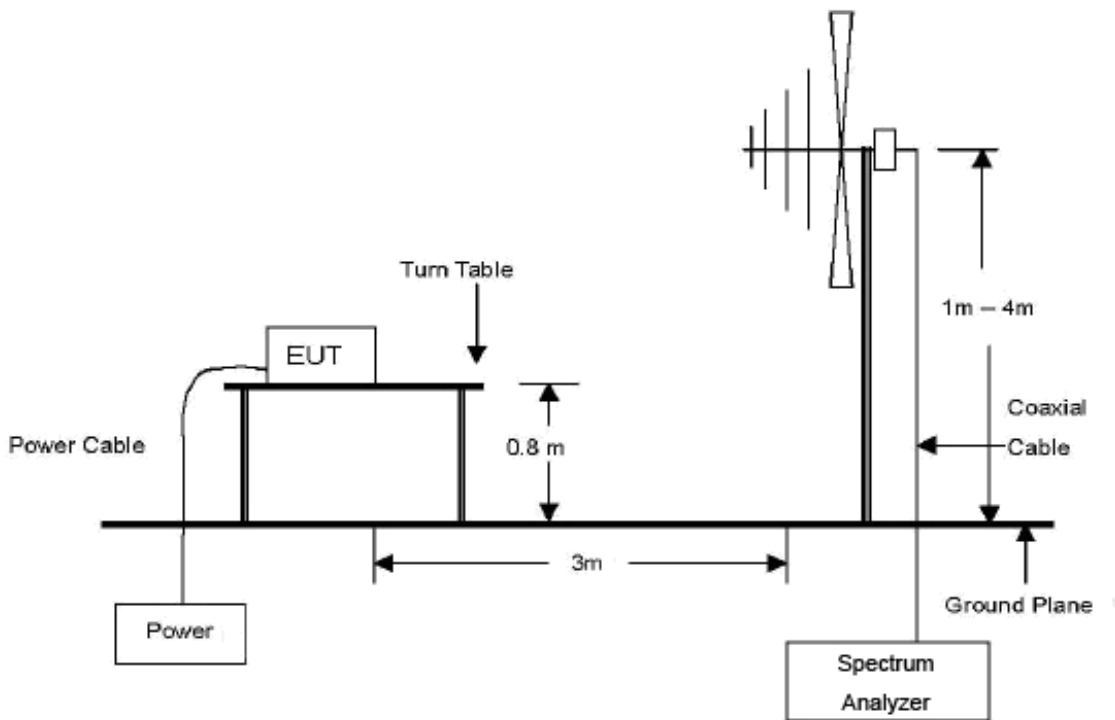

The results shown in this test report refer only to the sample(s) tested , This Test report cannot be reproduced, except in full, without prior written permission of the Company.

The diagram below shows the test setup that is utilized to make the measurements for emission from 1 GHz to 25 GHz Emissions.

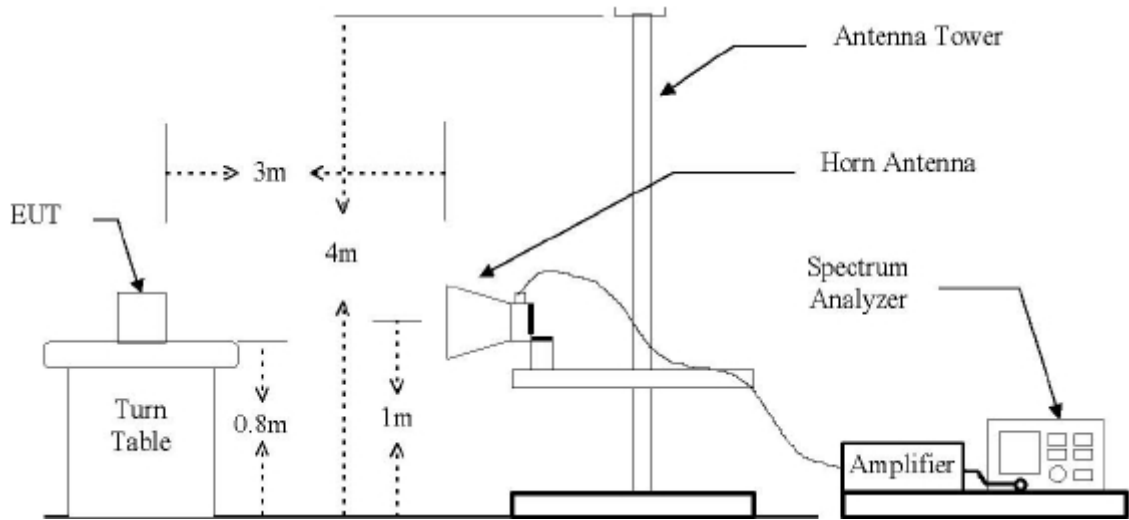

The results shown in this test report refer only to the sample(s) tested , This Test report cannot be reproduced, except in full, without prior written permission of the Company.

7.4 Spectrum Analyzer Setup

According to FCC Part15 Rules, the system was tested 26MHz to 25000MHz.

26MHz ~ 30MHz

Start Frequency	26MHz
Stop Frequency.....	30MHz
Sweep Speed.....	Auto
IF Bandwidth.....	10KHz
Video Bandwidth.....	10KHz
Resolution Bandwidth.....	10KHz

30MHz ~ 1GHz

Start Frequency	30 MHz
Stop Frequency.....	1000MHz
Sweep Speed.....	Auto
IF Bandwidth.....	120 KHz
Video Bandwidth.....	100KHz
Quasi-Peak Adapter Bandwidth	120 KHz
Quasi-Peak Adapter Mode	Normal
Resolution Bandwidth	100KHz

Above 1GHz

Start Frequency	1000 MHz
Stop Frequency.....	25000MHz
Sweep Speed.....	Auto
IF Bandwidth.....	120 KHz
Video Bandwidth.....	3MHz
Quasi-Peak Adapter Bandwidth	120 KHz
Quasi-Peak Adapter Mode	Normal
Resolution Bandwidth	1MHz

7.5 Test Procedure

1. The EUT is placed on a turntable, which is 0.8m above ground plane.
2. The turntable shall be rotated for 360 degrees to determine the position of maximum emission level.
3. EUT is set 3m away from the receiving antenna, which is moved from 1m to 4m to find out the maximum emissions.
4. Maximum procedure was performed on the six highest emissions to ensure EUT compliance.
5. And also, each emission was to be maximized by changing the polarization of receiving antenna both horizontal and vertical.
6. Repeat above procedures until the measurements for all frequencies are complete.
7. The radiation measurements are performed in X(normal uses) axis positioning. And all the modes was tested in the report. Only the worst case is shown in the report.

7.6 Corrected Amplitude & Margin Calculation

The Corrected Amplitude is calculated by adding the Antenna Factor and Cable Factor, and subtracting the Amplifier Gain from the Amplitude reading. The basic equation is as follows:

$$\text{Corr. Ampl.} = \text{Indicated Reading} + \text{Antenna Factor} + \text{Cable Factor} - \text{Amplifier Gain}$$

The “**Margin**” column of the following data tables indicates the degree of compliance with the applicable limit. For example, a margin of -7dB means the emission is 7dB below the maximum limit for Class B. The equation for margin calculation is as follows:

$$\text{Margin} = \text{Corr. Ampl.} - \text{Limit}$$

7.7 Summary of Test Results

According to the data in this section, the EUT complied with the FCC CFR47 Part 15 Section 15.209 & 15.247 Rules.

Test mode: continuously receive mode

Remark: the EUT was pretested at the high, middle and low channel, and the worse case was the middle Channel, so the data show was the low channel only.

Because the emissions below 30MHz are more than 20dB below the limit, the data is not show in the report.

Test Frequency : 30MHz ~ 1000MHz

Antenna polarization: Vertical

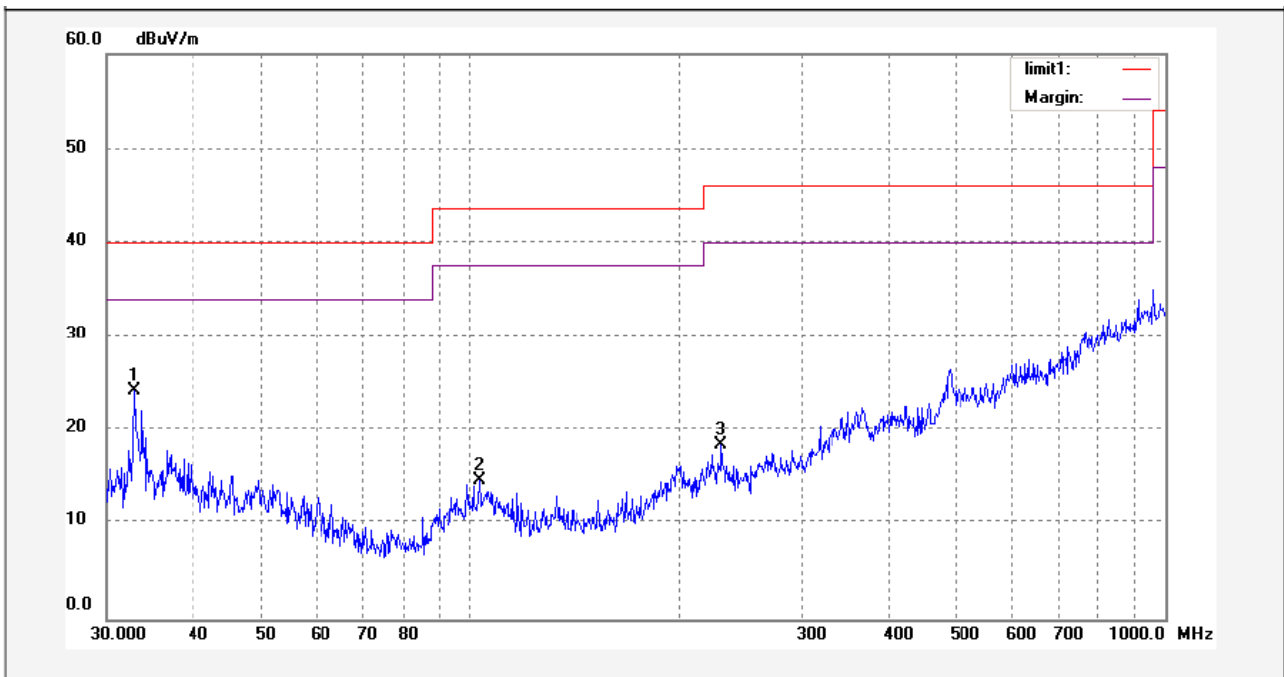

No.	Freq. (MHz)	Reading (dBuV/m)	Factor (dB)	Result (dBuV/m)	Limit (dBuV/m)	Margin (dB)	Detector	Remark
1	32.8697	7.72	16.57	24.29	40.00	-15.71	peak	
2	103.3353	0.60	14.16	14.76	43.50	-28.74	peak	
3	230.2295	2.34	16.19	18.53	46.00	-27.47	peak	

The results shown in this test report refer only to the sample(s) tested , This Test report cannot be reproduced, except in full, without prior written permission of the Company.

Antenna polarization: Horizontal

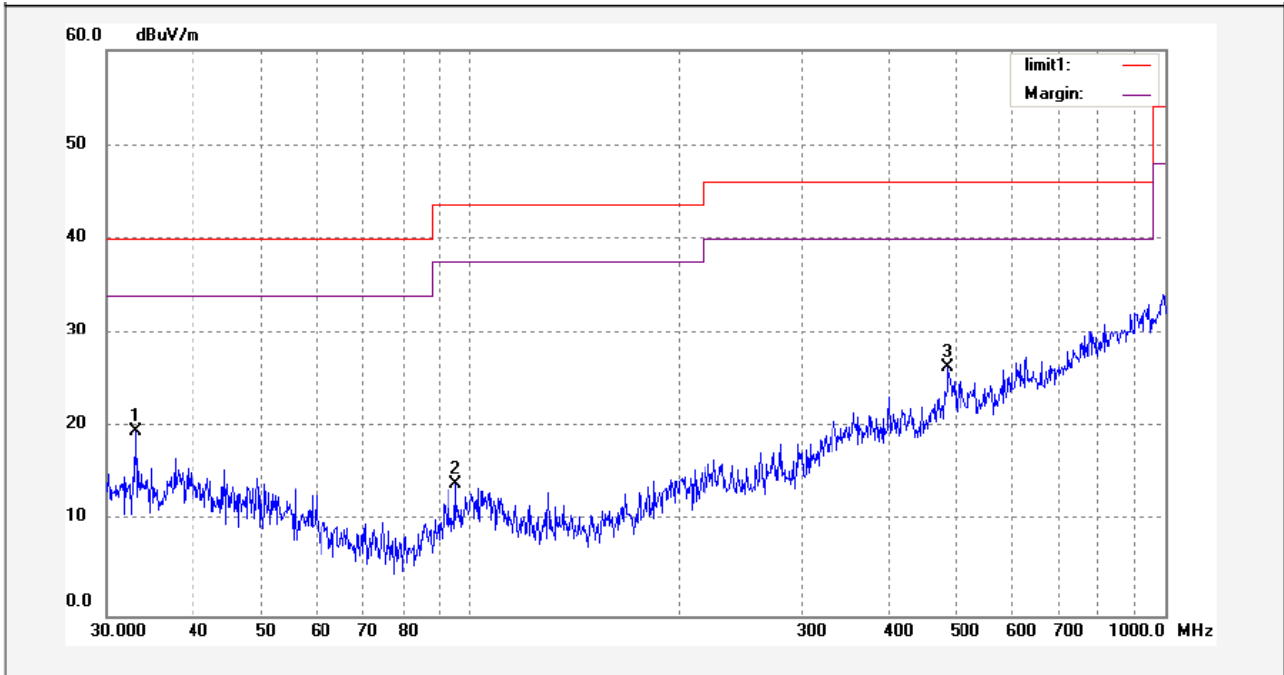

No.	Freq. (MHz)	Reading (dBuV/m)	Factor (dB)	Result (dBuV/m)	Limit (dBuV/m)	Margin (dB)	Detector	Remark
1	32.9854	2.94	16.57	19.51	40.00	-20.49	peak	
2	95.3131	0.75	13.21	13.96	43.50	-29.54	peak	
3	486.6136	1.54	24.72	26.26	46.00	-19.74	peak	

The results shown in this test report refer only to the sample(s) tested , This Test report cannot be reproduced, except in full, without prior written permission of the Company.

Test Frequency: Above 1GHz radiation test data:

Remark: No any emissions were found from 18GHz to 25 GHz, So the radiated emissions from 18GHz to 25GHz were not record.

Antenna polarization: Vertical

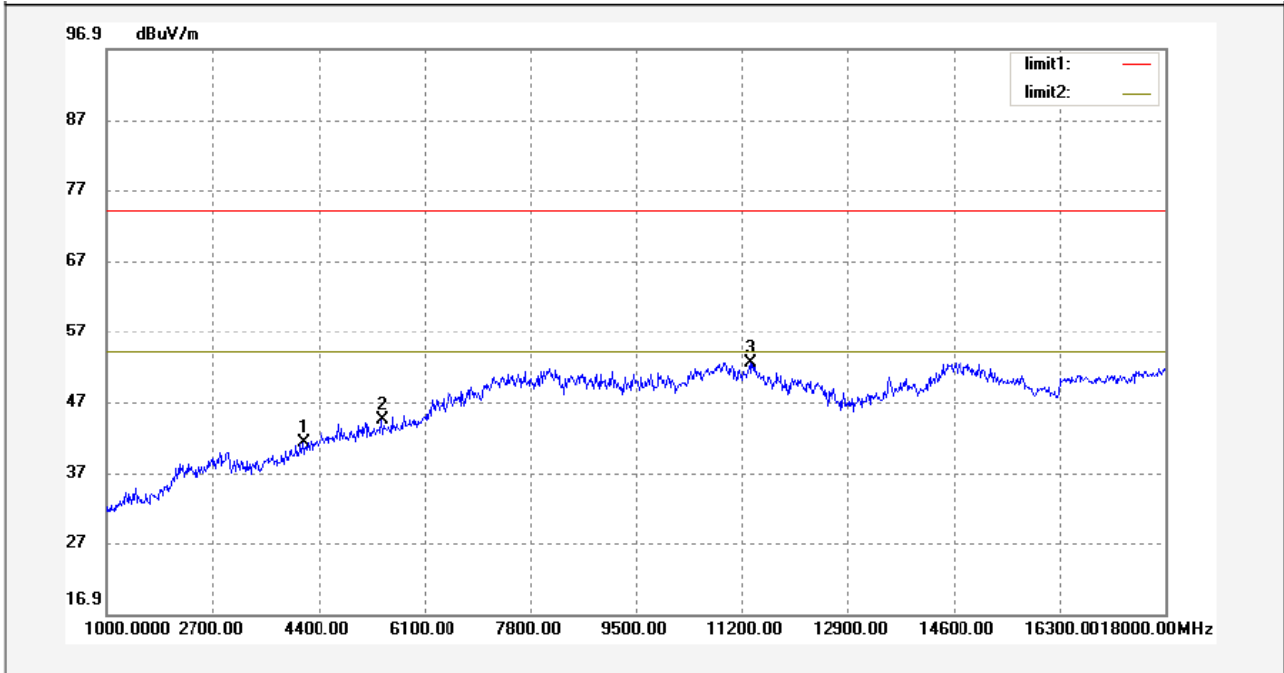

No.	Freq. (MHz)	Reading (dBuV/m)	Factor (dB)	Result (dBuV/m)	Limit (dBuV/m)	Margin (dB)	Detector	Remark
1	4134.269	47.35	-6.21	41.14	74.00	-32.86	peak	
2	5411.824	47.70	-3.37	44.33	74.00	-29.67	peak	
3	11339.679	42.28	10.12	52.40	74.00	-21.60	peak	

The results shown in this test report refer only to the sample(s) tested , This Test report cannot be reproduced, except in full, without prior written permission of the Company.

Antenna polarization: Horizontal

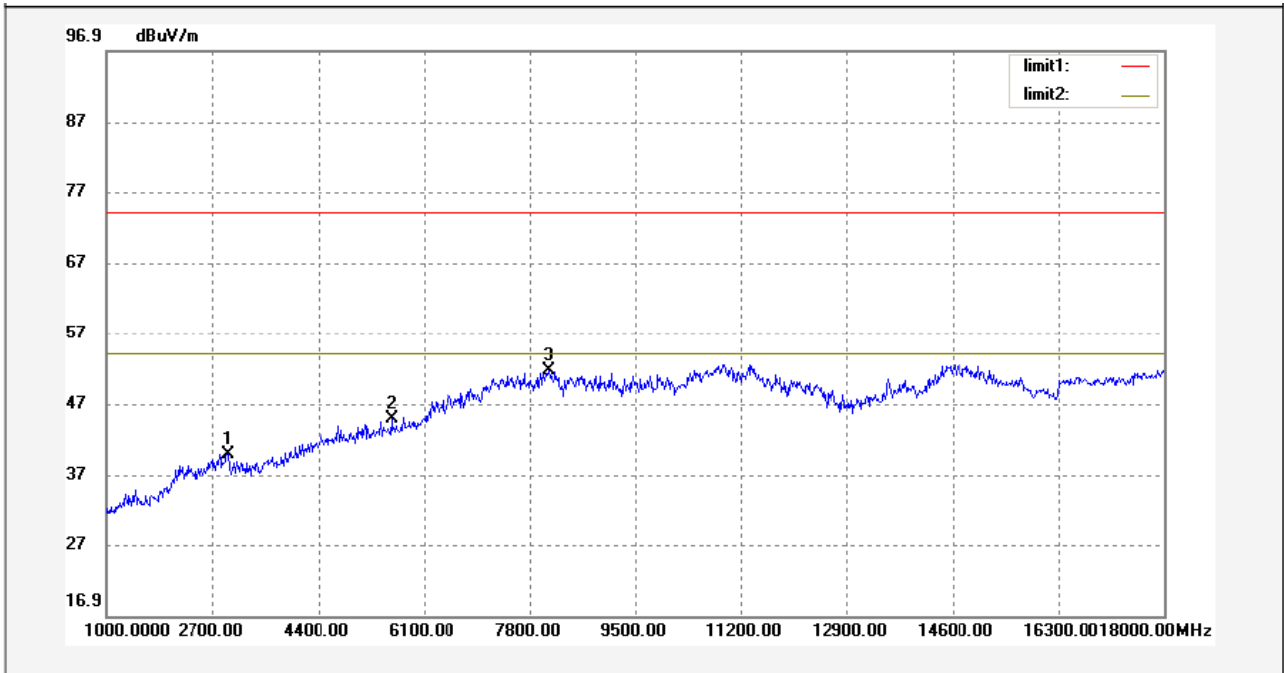

No.	Freq. (MHz)	Reading (dBuV/m)	Factor (dB)	Result (dBuV/m)	Limit (dBuV/m)	Margin (dB)	Detector	Remark
1	2941.884	48.64	-8.75	39.89	74.00	-34.11	peak	
2	5582.164	47.93	-3.06	44.87	74.00	-29.13	peak	
3	8103.206	47.27	4.33	51.60	74.00	-22.40	peak	

The results shown in this test report refer only to the sample(s) tested , This Test report cannot be reproduced, except in full, without prior written permission of the Company.

Test mode: normal link mode

Remark: Because the emissions below 30MHz are more than 20dB below the limit, the data is not show in the report.

Test Frequency : 30MHz ~ 1000MHz

Antenna polarization: Vertical

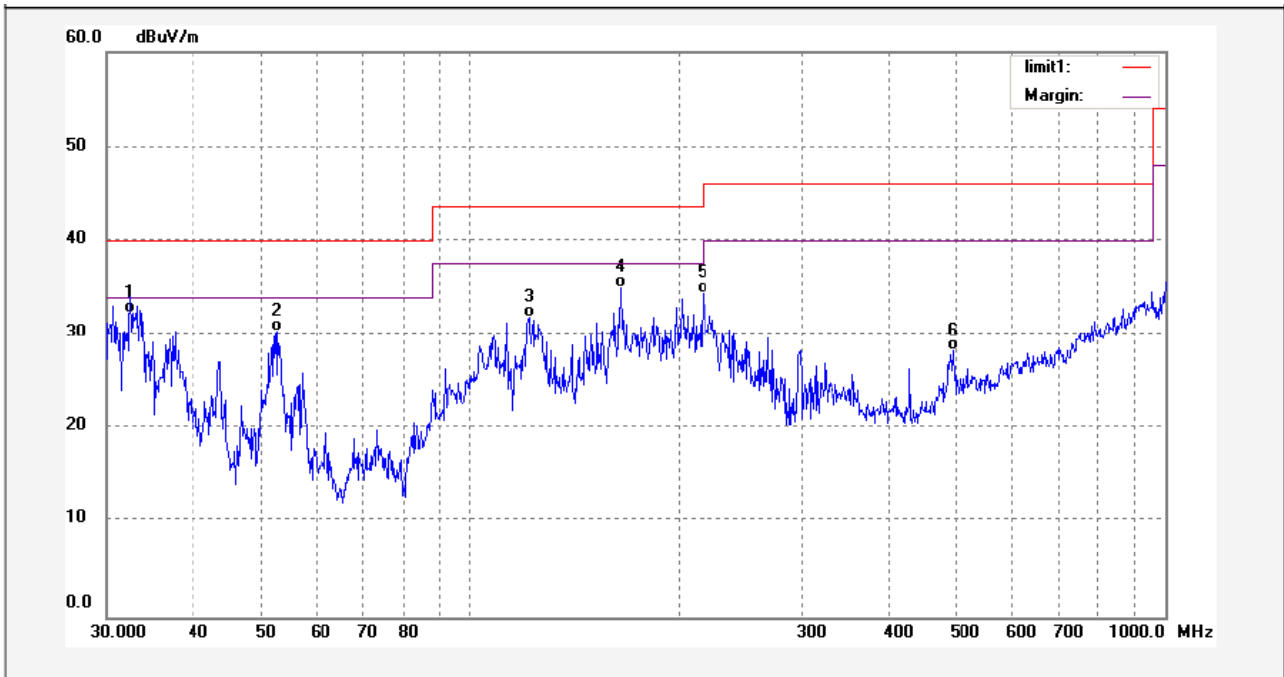

No.	Freq. (MHz)	Reading (dBuV/m)	Factor (dB)	Result (dBuV/m)	Limit (dBuV/m)	Margin (dB)	Detector	Remark
1	32.4109	15.82	16.58	32.40	40.00	-7.60	QP	
2	52.8197	16.08	14.31	30.39	40.00	-9.61	QP	
3	121.4623	20.10	11.81	31.91	43.50	-11.59	QP	
4	164.8912	23.09	11.94	35.03	43.50	-8.47	QP	
5	216.1197	19.11	15.33	34.44	46.00	-11.56	QP	
6	495.2379	3.88	24.38	28.26	46.00	-17.74	QP	

The results shown in this test report refer only to the sample(s) tested , This Test report cannot be reproduced, except in full, without prior written permission of the Company.

Antenna polarization: Horizontal

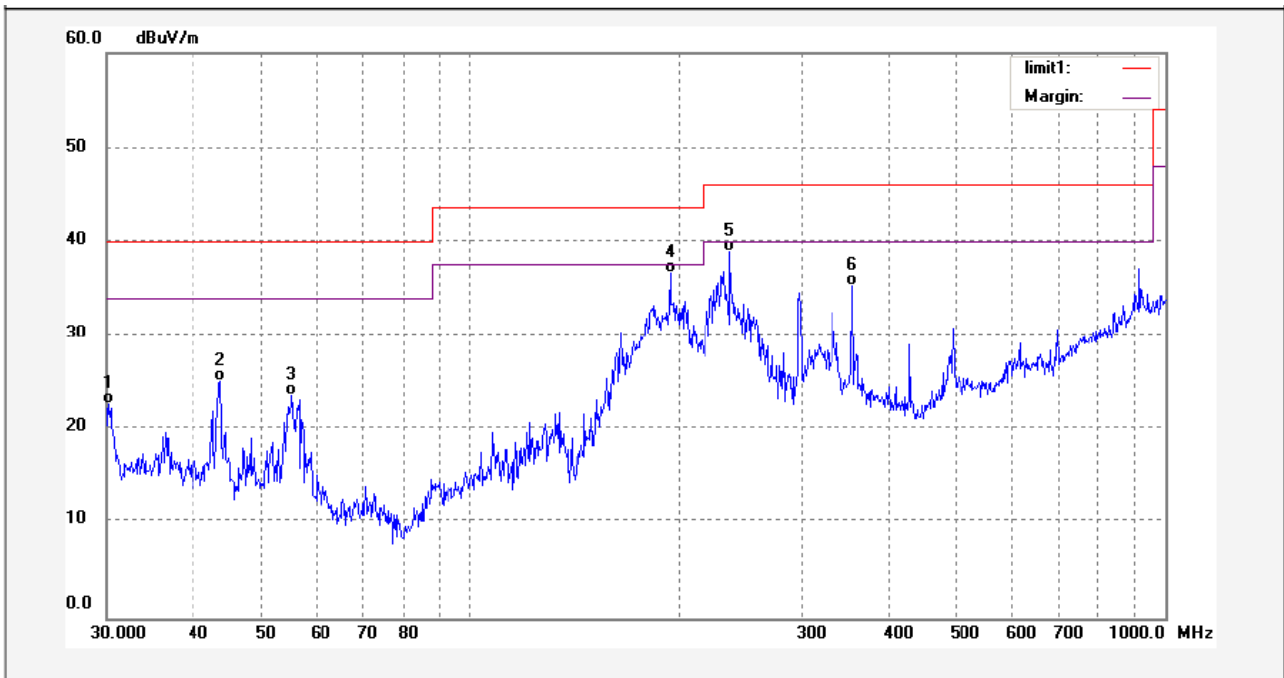

No.	Freq. (MHz)	Reading (dBuV/m)	Factor (dB)	Result (dBuV/m)	Limit (dBuV/m)	Margin (dB)	Detector	Remark
1	30.2116	6.52	16.19	22.71	40.00	-17.29	QP	
2	43.6914	10.11	15.07	25.18	40.00	-14.82	QP	
3	55.2883	9.94	13.72	23.66	40.00	-16.34	QP	
4	193.8163	21.92	14.69	36.61	43.50	-6.89	QP	
5	236.7928	23.20	15.66	38.86	46.00	-7.14	QP	
6	354.6912	14.85	20.43	35.28	46.00	-10.72	QP	

The results shown in this test report refer only to the sample(s) tested , This Test report cannot be reproduced, except in full, without prior written permission of the Company.

Test mode: connect PC Aux in mode

Remark: Because the emissions below 30MHz are more than 20dB below the limit, the data is not show in the report.

Test Frequency : 30MHz ~ 1000MHz

Antenna polarization: Vertical

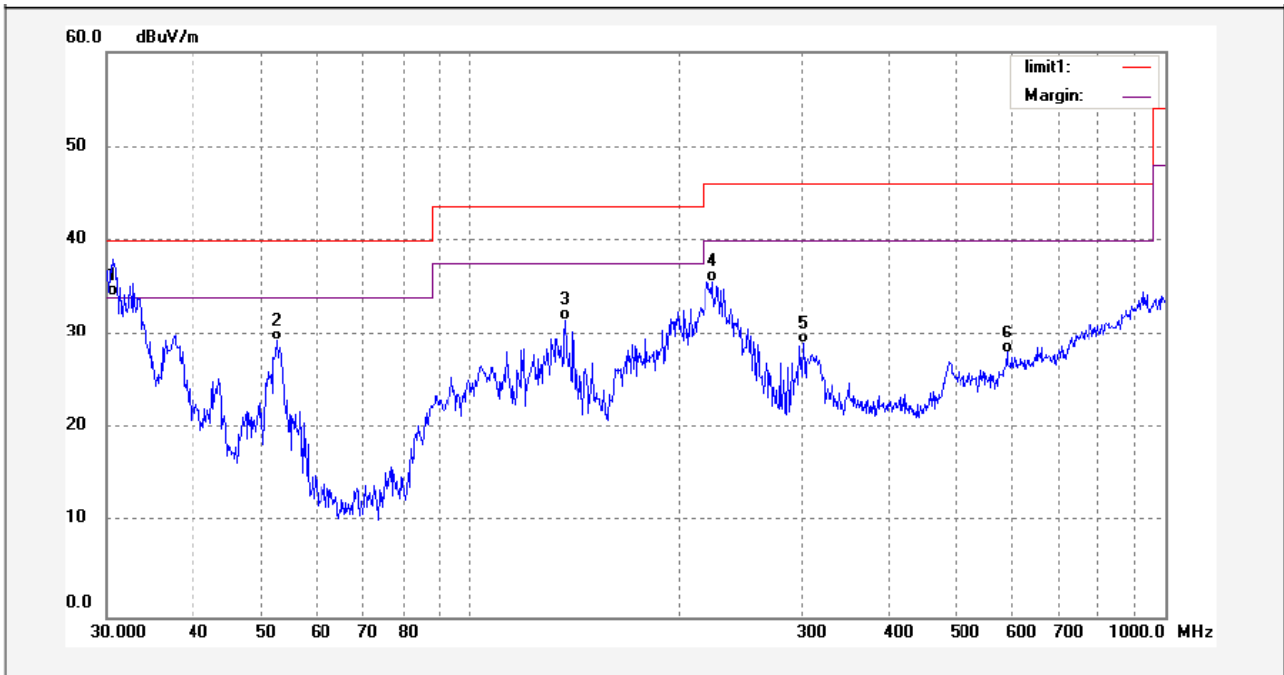

No.	Freq. (MHz)	Reading (dBuV/m)	Factor (dB)	Result (dBuV/m)	Limit (dBuV/m)	Margin (dB)	Detector	Remark
1	30.6392	17.86	16.29	34.15	40.00	-5.85	QP	
2	52.6345	15.00	14.35	29.35	40.00	-10.65	QP	
3	136.8747	19.62	11.94	31.56	43.50	-11.94	QP	
4	223.0630	19.40	16.27	35.67	46.00	-10.33	QP	
5	301.7572	11.84	17.19	29.03	46.00	-16.97	QP	
6	592.4290	2.93	25.12	28.05	46.00	-17.95	QP	

The results shown in this test report refer only to the sample(s) tested , This Test report cannot be reproduced, except in full, without prior written permission of the Company.

Antenna polarization: Horizontal

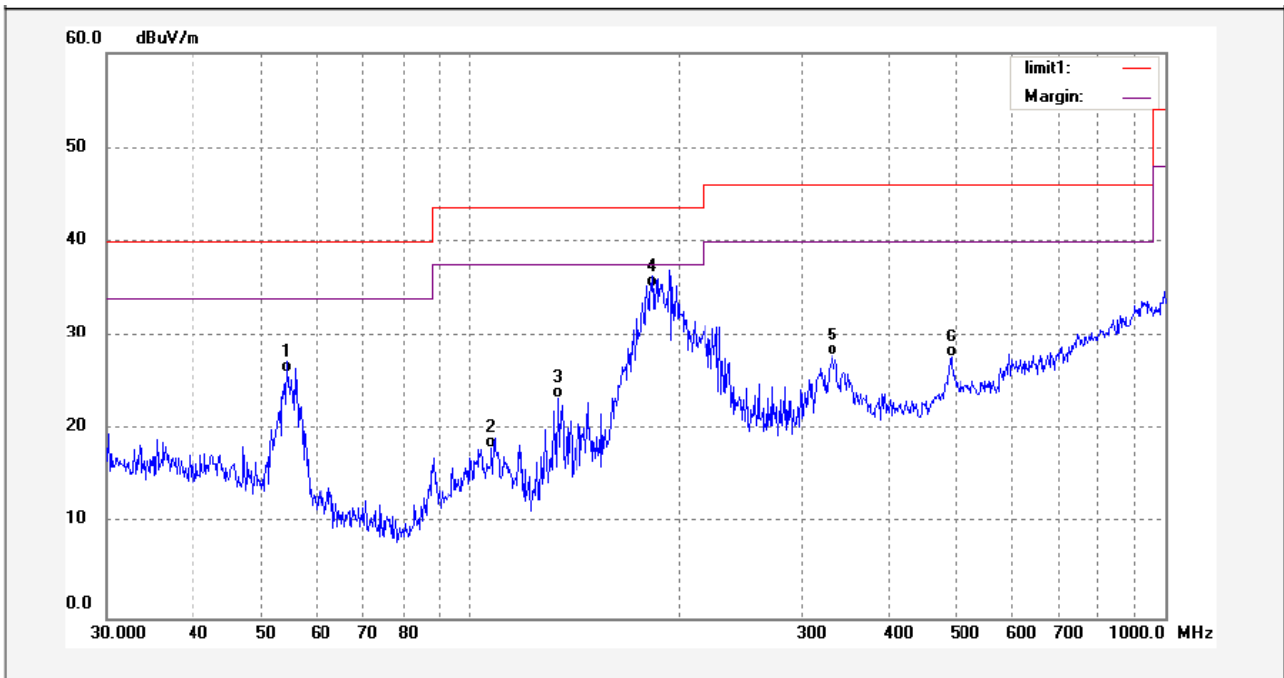

No.	Freq. (MHz)	Reading (dBuV/m)	Factor (dB)	Result (dBuV/m)	Limit (dBuV/m)	Margin (dB)	Detector	Remark
1	54.3255	12.05	13.94	25.99	40.00	-14.01	QP	
2	107.4074	4.13	14.01	18.14	43.50	-25.36	QP	
3	133.5493	11.30	12.08	23.38	43.50	-20.12	QP	
4	182.5785	21.57	13.58	35.15	43.50	-8.35	QP	
5	331.7858	8.54	19.34	27.88	46.00	-18.12	QP	
6	491.7700	2.35	25.29	27.64	46.00	-18.36	QP	

The results shown in this test report refer only to the sample(s) tested , This Test report cannot be reproduced, except in full, without prior written permission of the Company.

Test mode: continuously transmit mode

Remark: the EUT was pretested at the high, middle and low channel, and the worse case was the middle Channel, so the data show was the middle channel only.

Because the emissions below 30MHz are more than 20dB below the limit, the data is not show in the report.

Test Frequency : 30MHz ~ 1000MHz

Antenna polarization: Vertical

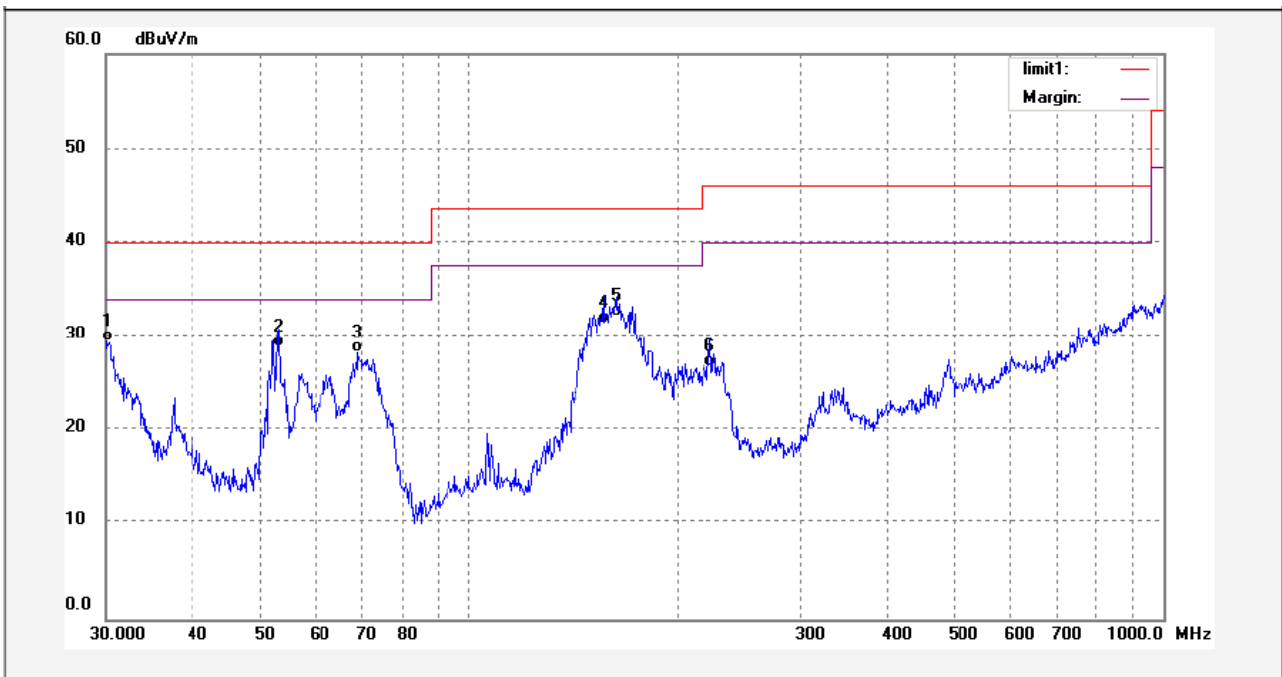

No.	Freq. (MHz)	Reading (dBuV/m)	Factor (dB)	Result (dBuV/m)	Limit (dBuV/m)	Margin (dB)	Detector	Remark
1	30.0000	13.26	16.15	29.41	40.00	-10.59	QP	
2	53.1922	14.68	14.21	28.89	40.00	-11.11	QP	
3	69.2297	18.26	10.08	28.34	40.00	-11.66	QP	
4	156.4259	20.40	10.96	31.36	43.50	-12.14	QP	
5	163.1623	20.50	11.71	32.21	43.50	-11.29	QP	
6	222.2807	10.55	16.23	26.78	46.00	-19.22	QP	

The results shown in this test report refer only to the sample(s) tested , This Test report cannot be reproduced, except in full, without prior written permission of the Company.

Antenna polarization: Horizontal

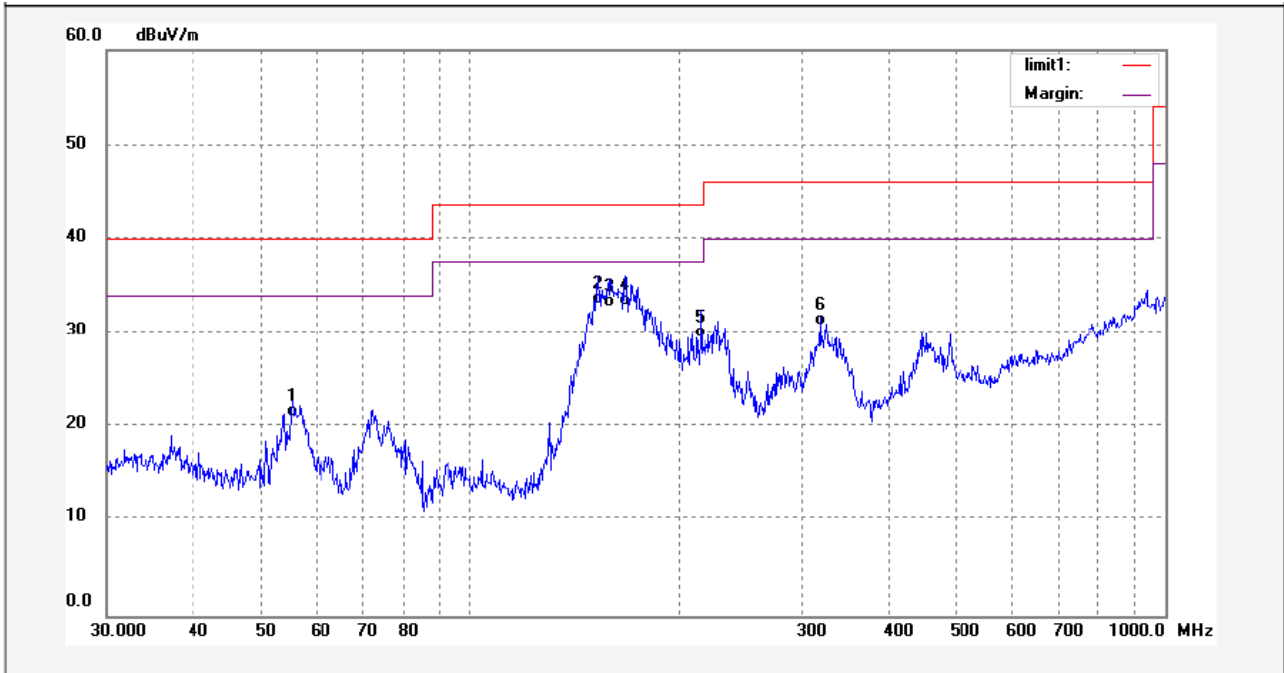

No.	Freq. (MHz)	Reading (dBuV/m)	Factor (dB)	Result (dBuV/m)	Limit (dBuV/m)	Margin (dB)	Detector	Remark
1	55.4829	7.36	13.67	21.03	40.00	-18.97	QP	
2	153.1627	22.17	10.92	33.09	43.50	-10.41	QP	
3	159.1983	21.53	11.22	32.75	43.50	-10.75	QP	
4	167.2250	21.00	12.00	33.00	43.50	-10.50	QP	
5	214.6063	14.44	15.08	29.52	43.50	-13.98	QP	
6	318.0875	12.20	18.56	30.76	46.00	-15.24	QP	

The results shown in this test report refer only to the sample(s) tested , This Test report cannot be reproduced, except in full, without prior written permission of the Company.

Test Frequency: 1GHz ~ 25GHz

And the below is the Fundamental and Harmonic

Frequency (MHz)	Detector	Antenna Polarization	Emission Level (dBuV/m)	Limit (dBuV/m)	Margin (dB)	Antenna Height (m)	Turntable Angle (°)
Low frequency							
2402.00	AV	Vertical	94.95		(Fund.)	1.4	50
4804.00	AV	Vertical	40.15	54.00	-13.85	1.1	105
7206.00	AV	Vertical	39.54	54.00	-14.46	1.6	160
9608.00	AV	Vertical	38.12	54.00	-15.88	1.7	110
12010.00	AV	Vertical	35.41	54.00	-18.59	1.8	195
14412.00	AV	Vertical	33.15	54.00	-20.85	1.3	160
16814.00	AV	Vertical	34.85	54.00	-19.15	1.8	150
19216.00	AV	Vertical	35.48	54.00	-18.52	1.4	120
21618.00	AV	Vertical	30.42	54.00	-23.58	1.7	40
24020.00	AV	Vertical	36.15	54.00	-17.85	1.1	110
2402.00	AV	Horizontal	86.98		(Fund.)	1.3	60
4804.00	AV	Horizontal	36.48	54.00	-17.52	1.1	160
7206.00	AV	Horizontal	34.2	54.00	-19.8	1.6	110
9608.00	AV	Horizontal	35.15	54.00	-18.85	1.1	160
12010.00	AV	Horizontal	32.15	54.00	-21.85	1.6	100
14412.00	AV	Horizontal	30.15	54.00	-23.85	1.1	170
16814.00	AV	Horizontal	35.88	54.00	-18.12	1.6	160
19216.00	AV	Horizontal	34.48	54.00	-19.52	1.7	140
21618.00	AV	Horizontal	30.45	54.00	-23.55	1.3	150
24020.00	AV	Horizontal	48.14	54.00	-5.86	1.4	70
2402.00	PK	Vertical	101.52		(Fund.)	1.6	40
4804.00	PK	Vertical	57.15	74.00	-16.85	1.7	110
7206.00	PK	Vertical	59.64	74.00	-14.36	1.8	150
9608.00	PK	Vertical	57.12	74.00	-16.88	1.3	220
12010.00	PK	Vertical	50.21	74.00	-23.79	1.3	110
14412.00	PK	Vertical	51.05	74.00	-22.95	1.1	120
16814.00	PK	Vertical	49.88	74.00	-24.12	1.5	175
19216.00	PK	Vertical	46.84	74.00	-27.16	1.1	170
21618.00	PK	Vertical	48.68	74.00	-25.32	1.8	120
24020.00	PK	Vertical	48.99	74.00	-25.01	1.3	130
2402.00	PK	Horizontal	96.48		(Fund.)	1.9	110
4804.00	PK	Horizontal	54.98	74.00	-19.02	1.7	150
7206.00	PK	Horizontal	55.89	74.00	-18.11	1.9	100
9608.00	PK	Horizontal	51.25	74.00	-22.75	1.1	50
12010.00	PK	Horizontal	50.48	74.00	-23.52	1.3	195
14412.00	PK	Horizontal	49.02	74.00	-24.98	1.4	40
16814.00	PK	Horizontal	48.57	74.00	-25.43	1.9	230
19216.00	PK	Horizontal	49.48	74.00	-24.52	1.4	120

The results shown in this test report refer only to the sample(s) tested , This Test report cannot be reproduced, except in full, without prior written permission of the Company.

21618.00	PK	Horizontal	47.12	74.00	-26.88	1.3	160
24020.00	PK	Horizontal	45.24	74.00	-28.76	1.8	120
Middle frequency							
2441.00	AV	Vertical	95.48		(Fund.)	1.6	80
4882.00	AV	Vertical	41.95	54.00	-12.05	1.5	150
7323.00	AV	Vertical	40.25	54.00	-13.75	1.2	130
9764.00	AV	Vertical	38.33	54.00	-15.67	1.1	50
12205.00	AV	Vertical	40.44	54.00	-13.56	1.4	60
14646.00	AV	Vertical	35.25	54.00	-18.75	1.1	190
17087.00	AV	Vertical	35.14	54.00	-18.86	1.6	50
19528.00	AV	Vertical	31.74	54.00	-22.26	1.4	60
21969.00	AV	Vertical	32.69	54.00	-21.31	1.9	220
24410.00	AV	Vertical	33.49	54.00	-20.51	1.1	140
2441.00	AV	Horizontal	91.08		(Fund.)	1.2	180
4882.00	AV	Horizontal	38.88	54.00	-15.12	1.5	130
7323.00	AV	Horizontal	39.45	54.00	-14.55	1.6	320
9764.00	AV	Horizontal	35.26	54.00	-18.74	1.1	180
12205.00	AV	Horizontal	33.17	54.00	-20.83	1.3	190
14646.00	AV	Horizontal	33.08	54.00	-20.92	1.3	230
17087.00	AV	Horizontal	30.15	54.00	-23.85	1.8	195
19528.00	AV	Horizontal	30.09	54.00	-23.91	1.3	130
21969.00	AV	Horizontal	29.89	54.00	-24.11	1.3	200
24410.00	AV	Horizontal	30.42	54.00	-23.58	1.6	180
2441.00	PK	Vertical	104.52		(Fund.)	1.3	40
4882.00	PK	Vertical	66.12	74.00	-7.88	1.0	140
7323.00	PK	Vertical	63.45	74.00	-10.55	1.5	160
9764.00	PK	Vertical	58.99	74.00	-15.01	1.2	160
12205.00	PK	Vertical	60.45	74.00	-13.55	1.8	230
14646.00	PK	Vertical	55.67	74.00	-18.33	1.1	60
17087.00	PK	Vertical	56.46	74.00	-17.54	1.5	40
19528.00	PK	Vertical	51.51	74.00	-22.49	1.4	170
21969.00	PK	Vertical	52.36	74.00	-21.64	1.6	195
24410.00	PK	Vertical	50.01	74.00	-23.99	1.3	160
2441.00	PK	Horizontal	100.52		(Fund.)	1.7	50
4882.00	PK	Horizontal	59.17	74.00	-14.83	1.6	105
7323.00	PK	Horizontal	57.85	74.00	-16.15	1.8	130
9764.00	PK	Horizontal	54.26	74.00	-19.74	1.6	110
12205.00	PK	Horizontal	55.14	74.00	-18.86	1.5	210
14646.00	PK	Horizontal	50.44	74.00	-23.56	1.4	190
17087.00	PK	Horizontal	49.98	74.00	-24.02	1.3	170
19528.00	PK	Horizontal	52.17	74.00	-21.83	1.4	210
21969.00	PK	Horizontal	53.26	74.00	-20.74	1.2	40
24410.00	PK	Horizontal	48.19	74.00	-25.81	1.5	195

The results shown in this test report refer only to the sample(s) tested , This Test report cannot be reproduced, except in full, without prior written permission of the Company.

High frequency							
2480.00	AV	Vertical	96.24		(Fund.)	1.6	230
4960.00	AV	Vertical	47.86	54.00	-6.14	1.5	60
7440.00	AV	Vertical	45.15	54.00	-8.85	1.4	160
9920.00	AV	Vertical	40.85	54.00	-13.15	1.3	110
12400.00	AV	Vertical	42.52	54.00	-11.48	1.6	150
14880.00	AV	Vertical	43.51	54.00	-10.49	1.7	160
17360.00	AV	Vertical	40.23	54.00	-13.77	1.2	150
19840.00	AV	Vertical	38.48	54.00	-15.52	1.5	240
22320.00	AV	Vertical	39.65	54.00	-14.35	1.5	160
24800.00	AV	Vertical	34.15	54.00	-19.85	1.4	185
2480.00	AV	Horizontal	92.99		(Fund.)	1.2	180
4960.00	AV	Horizontal	42.18	54.00	-11.82	2.1	190
7440.00	AV	Horizontal	40.59	54.00	-13.41	1.3	170
9920.00	AV	Horizontal	38.51	54.00	-15.49	1.4	240
12400.00	AV	Horizontal	39.45	54.00	-14.55	1.3	175
14880.00	AV	Horizontal	37.51	54.00	-16.49	1.8	170
17360.00	AV	Horizontal	33.12	54.00	-20.88	1.5	240
19840.00	AV	Horizontal	34.45	54.00	-19.55	2.0	100
22320.00	AV	Horizontal	30.85	54.00	-23.15	1.4	140
24800.00	AV	Horizontal	27.48	54.00	-26.52	2.3	150
2480.00	PK	Vertical	105.22		(Fund.)	1.3	220
4960.00	PK	Vertical	64.18	74.00	-9.82	1.1	80
7440.00	PK	Vertical	60.85	74.00	-13.15	2.2	170
9920.00	PK	Vertical	59.66	74.00	-14.34	1.4	140
12400.00	PK	Vertical	60.05	74.00	-13.95	1.5	140
14880.00	PK	Vertical	58.12	74.00	-15.88	1.1	120
17360.00	PK	Vertical	57.98	74.00	-16.02	1.3	130
19840.00	PK	Vertical	55.17	74.00	-18.83	1.1	170
22320.00	PK	Vertical	50.96	74.00	-23.04	1.9	180
24800.00	PK	Vertical	47.98	74.00	-26.02	1.5	175
2480.00	PK	Horizontal	100.89		(Fund.)	1.8	230
4960.00	PK	Horizontal	58.45	74.00	-15.55	1.3	120
7440.00	PK	Horizontal	57.84	74.00	-16.16	1.6	160
9920.00	PK	Horizontal	55.16	74.00	-18.84	1.2	230
12400.00	PK	Horizontal	50.45	74.00	-23.55	1.3	150
14880.00	PK	Horizontal	51.96	74.00	-22.04	1.9	130
17360.00	PK	Horizontal	48.99	74.00	-25.01	2.0	200
19840.00	PK	Horizontal	46.15	74.00	-27.85	1.4	210
22320.00	PK	Horizontal	47.98	74.00	-26.02	2.4	160
24800.00	PK	Horizontal	42.19	74.00	-31.81	1.6	240

The results shown in this test report refer only to the sample(s) tested , This Test report cannot be reproduced, except in full, without prior written permission of the Company.

7.8 Photograph – Radiation Spurious Emission Test Setup

Below 1GHz



30MHz - 1GHz

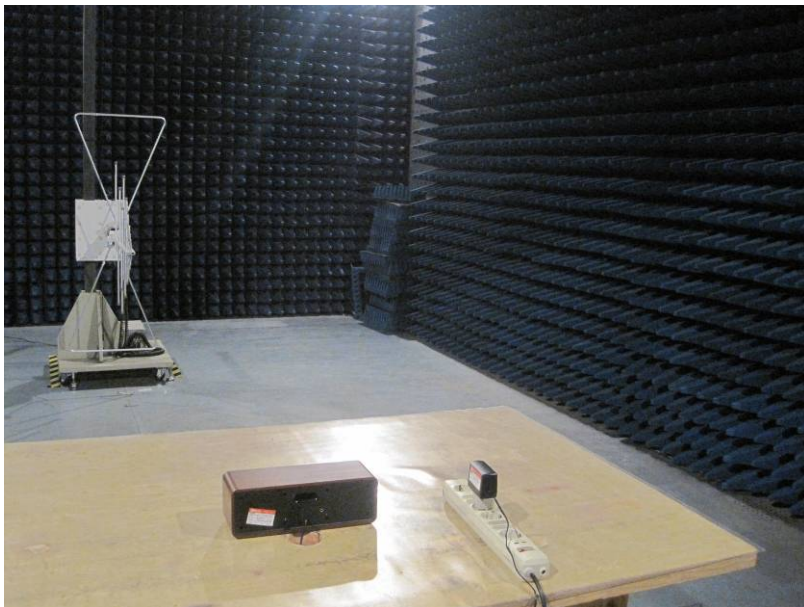

The results shown in this test report refer only to the sample(s) tested , This Test report cannot be reproduced, except in full, without prior written permission of the Company.

WALTEK SERVICES

Reference No.: WT12075138-S-S-F

Above 1GHz



The results shown in this test report refer only to the sample(s) tested , This Test report cannot be reproduced, except in full, without prior written permission of the Company.

WALTEK SERVICES

Reference No.: WT12075138-S-S-F

8 Band Edge Measurements

Test Requirement:	Section 15.247(d) In addition, radiated emissions which fall in the restricted bands. as defined in Section 15.205(a), must also comply with the radiated emission limits specified in Section 15.209(a) (see Section 15.205(c)).
Test Method:	Based on DA 00-705
Measurement Distance:	3m
Limit:	40.0 dBuV/m between 30MHz & 88MHz; 43.5 dBuV/m between 88MHz & 216MHz; 46.0 dBuV/m between 216MHz & 960MHz; 54.0 dBuV/m above 960MHz. 74.0 dBuV/m for peak above 1GHz 54.0 dBuV/m for AVG above 1GHz
Detector:	For Peak value: RBW = 1 MHz for $f \geq 1$ GHz VBW \geq RBW; Sweep = auto Detector function = peak Trace = max hold For AVG value: RBW = 1 MHz for $f \geq 1$ GHz VBW = 10Hz; Sweep = auto Detector function = AVG Trace = max hold

Test Result:
Low Channel – Peak

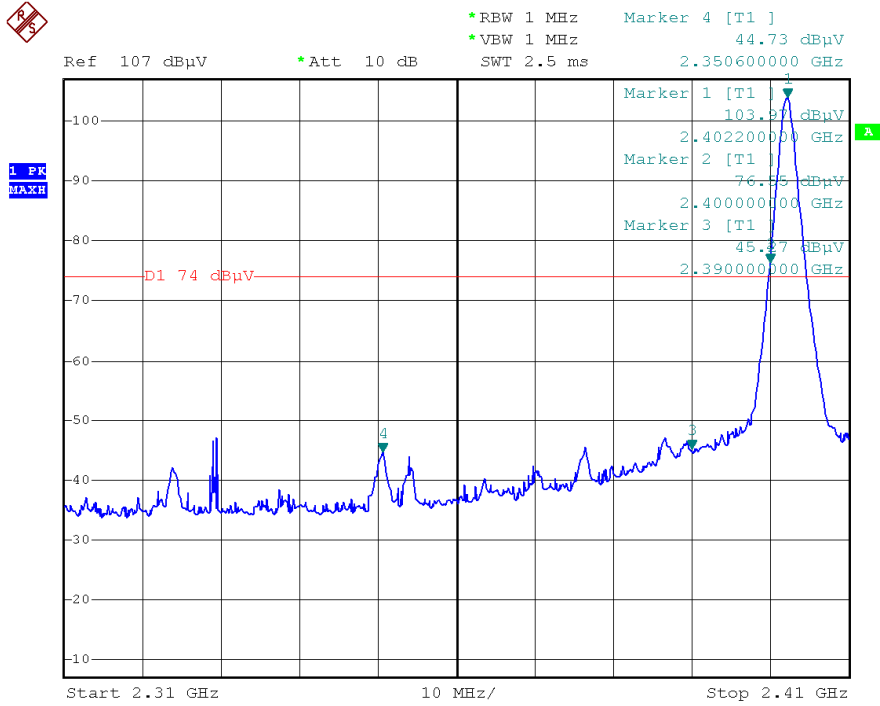

The results shown in this test report refer only to the sample(s) tested , This Test report cannot be reproduced, except in full, without prior written permission of the Company.

Low Channel – AV

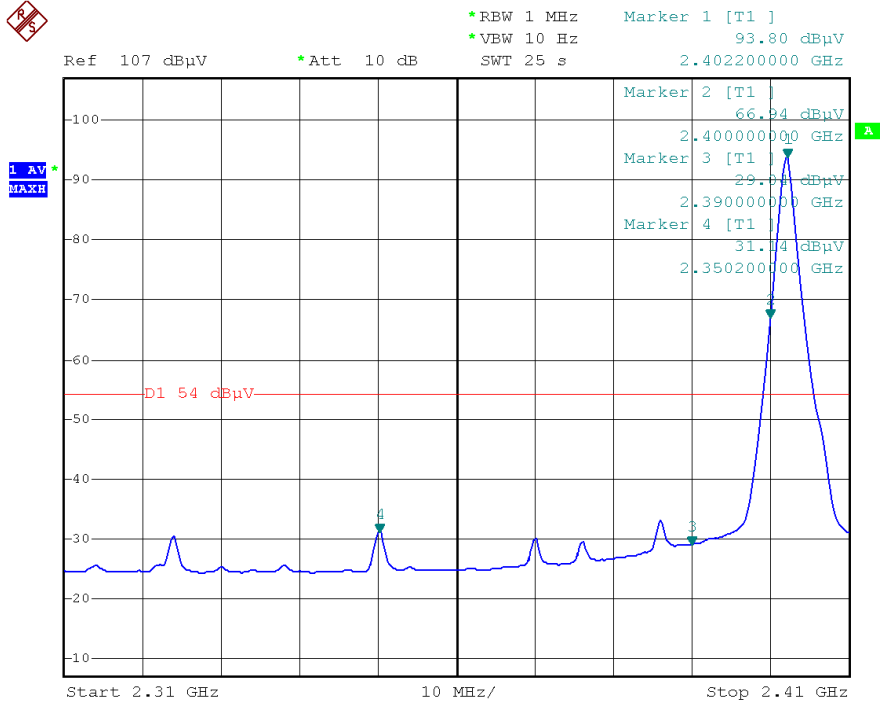

The results shown in this test report refer only to the sample(s) tested , This Test report cannot be reproduced, except in full, without prior written permission of the Company.

High Channel – Peak

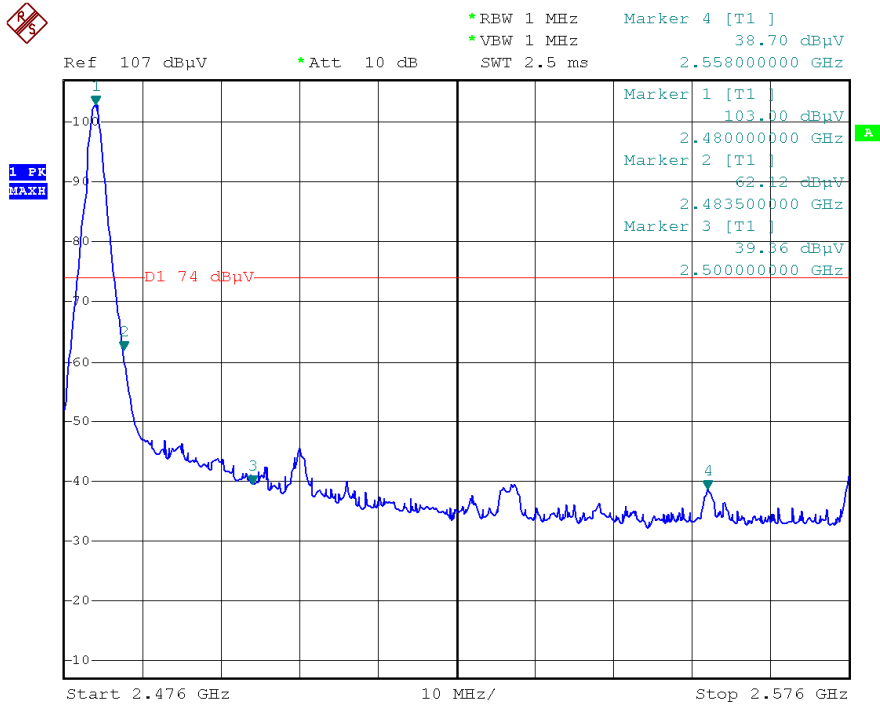

The results shown in this test report refer only to the sample(s) tested , This Test report cannot be reproduced, except in full, without prior written permission of the Company.

High Channel – AV

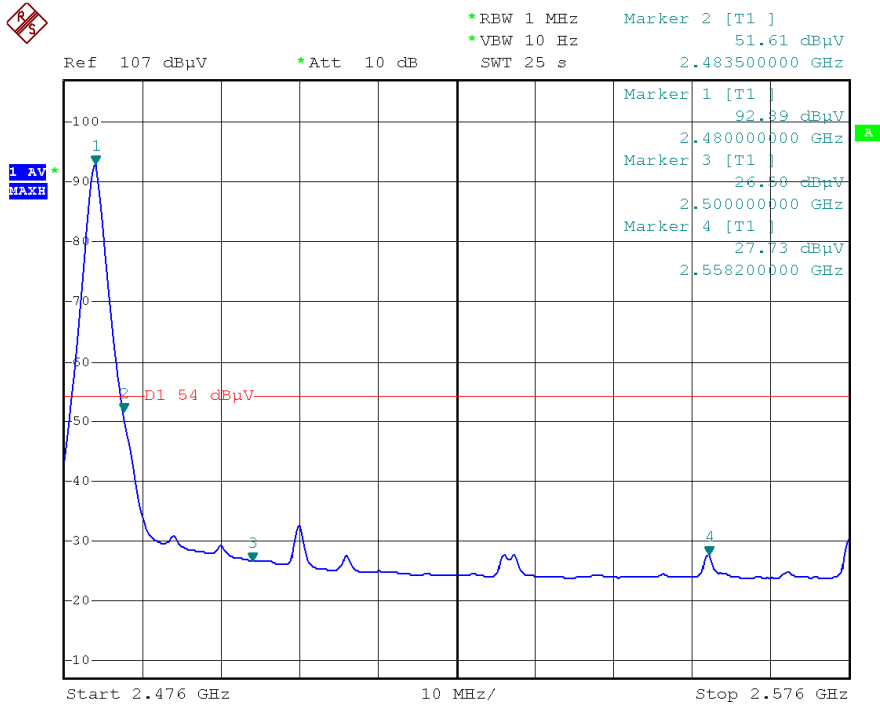

The results shown in this test report refer only to the sample(s) tested , This Test report cannot be reproduced, except in full, without prior written permission of the Company.

9 20 dB Bandwidth Measurement

Test Requirement: FCC CFR47 Part 15 Section 15.247
 Test Method: Based on DA 00-705
 Test Mode: Test in fixing operating frequency at low, Middle, high channel.

9.1 Test Procedure:

1. Remove the antenna from the EUT and then connect a low RF cable from the antenna port to the spectrum;
2. Set the spectrum analyzer: Span = 3MHz, RBW = 100kHz, VBW = 100kHz

9.2 Test Result:

Test Channel	Bandwidth
Low	1.128MHz
Middle	1.086MHz
High	1.086MHz

Test result plot as follows:

Low Channel



The results shown in this test report refer only to the sample(s) tested , This Test report cannot be reproduced, except in full, without prior written permission of the Company.

Middle Channel

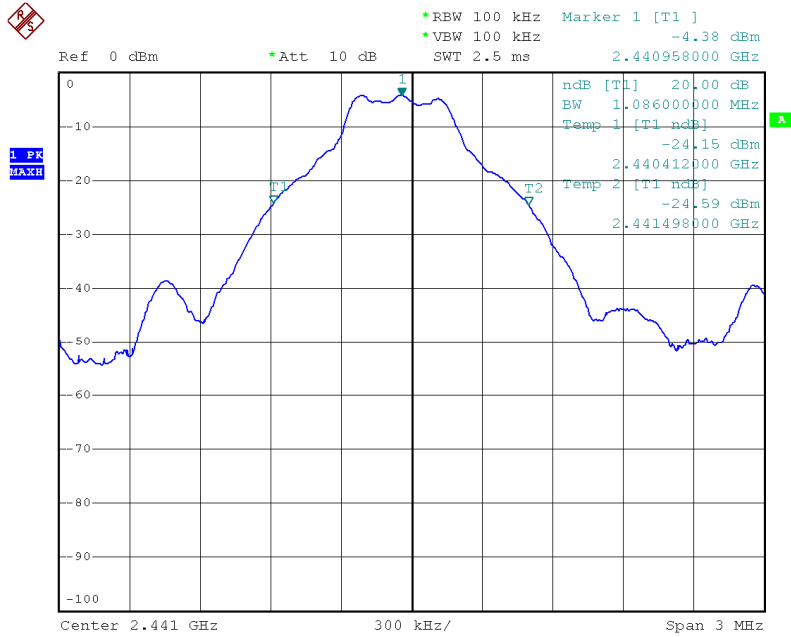

High Channel

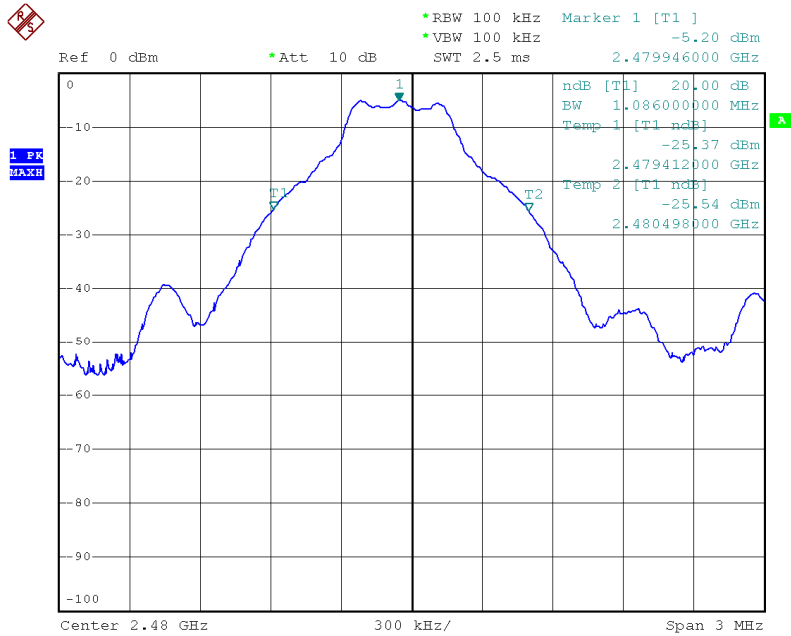

The results shown in this test report refer only to the sample(s) tested , This Test report cannot be reproduced, except in full, without prior written permission of the Company.

10 Maximum Peak Output Power

Test Requirement:	FCC CFR47 Part 15 Section 15.247
Test Method:	Based on ANSI C63.4:2003
Test Limit:	Regulation 15.247 (b)(1)For frequency hopping systems operating in the 2400-2483.5 MHz band employing at least 75 non-overlapping hopping channels, and all frequency hopping systems in the 5725-5850 MHz band: 1 watt. For all other frequency hopping systems in the 2400-2483.5 MHz band: 0.125 watts. Refer to the result “Number of Hopping Frequency” of this document. The 1 watts (30 dBm) limit applies.
Test mode:	Test in fixing frequency transmitting mode.

10.1 Test Procedure:

1. Remove the antenna from the EUT and then connect a low RF cable from the antenna port to the spectrum.
2. Set the spectrum analyzer: RBW = 3 MHz. VBW = 10 MHz. Sweep = auto; Detector Function = Peak.
3. Keep the EUT in transmitting at lowest, medium and highest channel individually. Record the max value.

10.2 Test Result:

Test Channel	Output Power (dBm)	Limit (dBm)
Low	-3.27	30
Middle	-4.08	30
High	-4.92	30

11 Hopping Channel Separation

Test Requirement:	FCC CFR47 Part 15 Section 15.247
Test Method:	Based on DA 00-705
Test Limit:	Regulation 15.247(a)(1) Frequency hopping systems shall have hopping channel carrier frequencies separated by a minimum of 25 kHz or the 20 dB bandwidth of the hopping channel, whichever is greater. Alternatively, frequency hopping systems operating in the 2400-2483.5 MHz band may have hopping channel carrier frequencies that are separated by 25 kHz or two-thirds of the 20 dB bandwidth of the hopping channel, whichever is greater, provided the systems operate with an output power no greater than 125 mW.
Test Mode:	Test in hopping transmitting operating mode.

11.1 Test Procedure:

1. Remove the antenna from the EUT and then connect a low RF cable from the antenna port to the spectrum.
2. Set the spectrum analyzer: RBW = 30kHz. VBW = 100kHz , Span = 2MHz. Sweep = auto; Detector Function = Peak. Trace = Max hold.
3. Allow the trace to stabilize. Use the marker-delta function to determine the separation between the peaks of the adjacent channels. The limit is specified in one of the subparagraphs of this Section Submit this plot.

11.2 Test Result:

Test Channel	Separation (MHz)	Result
Low	1.000	PASS
Middle	1.000	PASS
High	1.000	PASS

Test result plot as follows:

Low Channel:

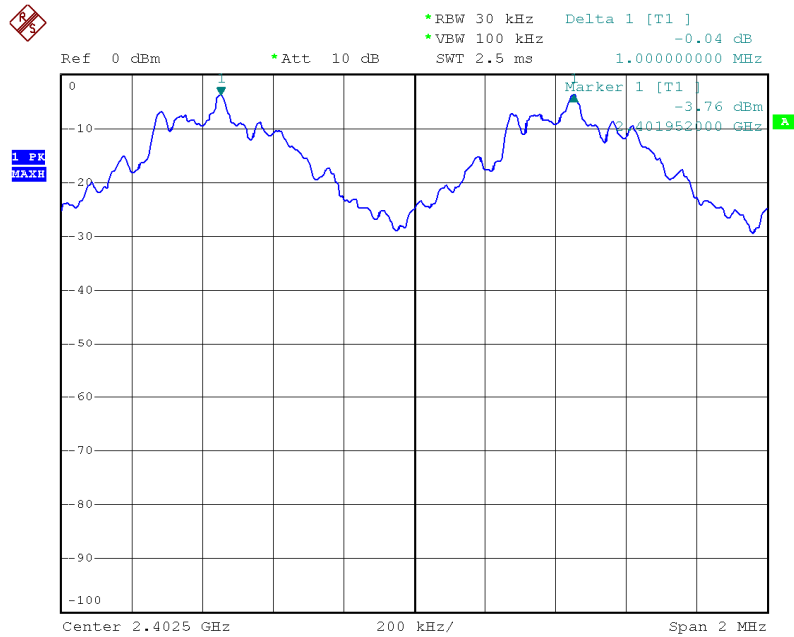

Middle Channel

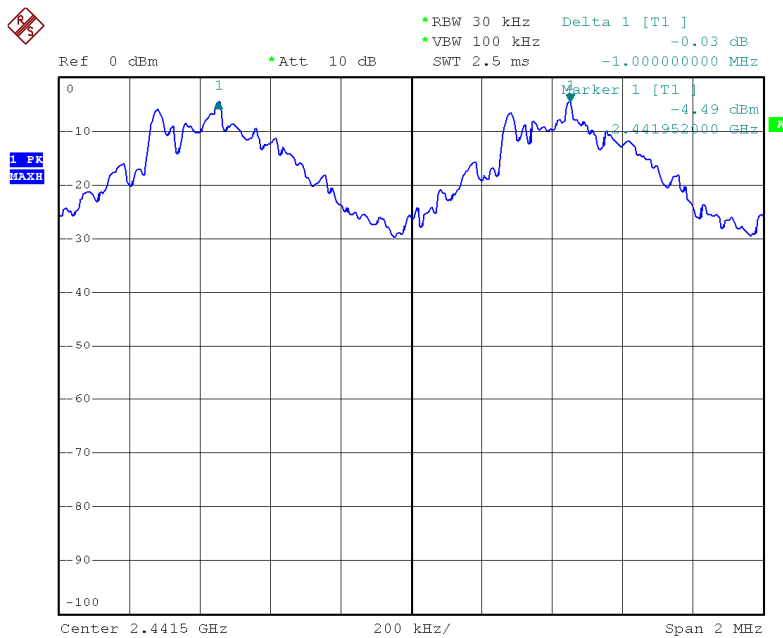

The results shown in this test report refer only to the sample(s) tested , This Test report cannot be reproduced, except in full, without prior written permission of the Company.

High Channel

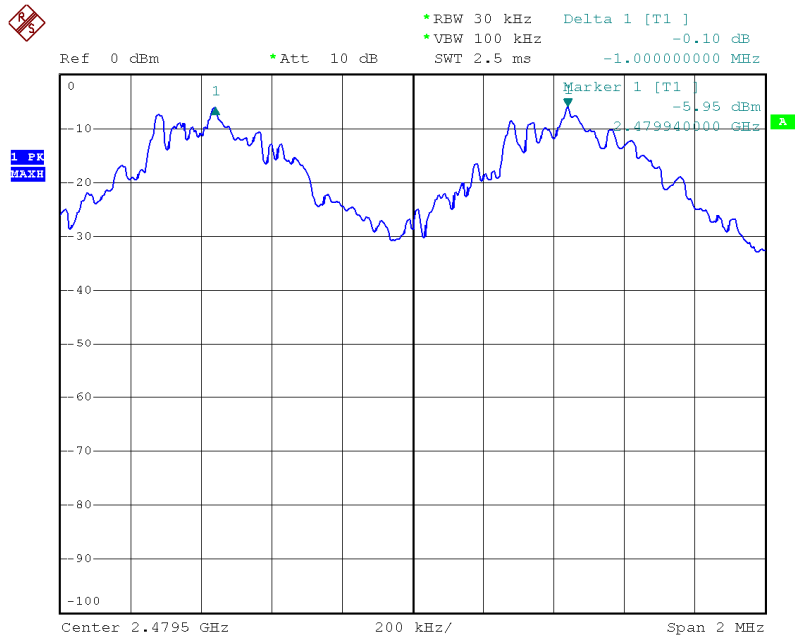

The results shown in this test report refer only to the sample(s) tested , This Test report cannot be reproduced, except in full, without prior written permission of the Company.

12 Number of Hopping Frequency

Test Requirement:	FCC CFR47 Part 15 Section 15.247
Test Method:	Based on DA 00-705
Test Limit:	Regulation 15.247 (a)(1)(iii) Frequency hopping systems in the 2400-2483.5 MHz band shall use at least 15 channels.
Test Mode:	Test in hopping transmitting operating mode.

12.1 Test Procedure:

1. Remove the antenna from the EUT and then connect a low RF cable from the antenna port to the spectrum.
2. Set the spectrum analyzer: RBW = 100 kHz. VBW = 100 kHz. Sweep = auto; Detector Function = Peak. Trace = Max hold.
3. Allow the trace to stabilize. It may prove necessary to break the span up to sections. in order to clearly show all of the hopping frequencies. The limit is specified in one of the subparagraphs of this Section.
4. Set the spectrum analyzer: Center Frequency = 2441MHz, Span = 86MHz. Submit the test result graph.

12.2 Test Result: Total Channels are 79 Channels.

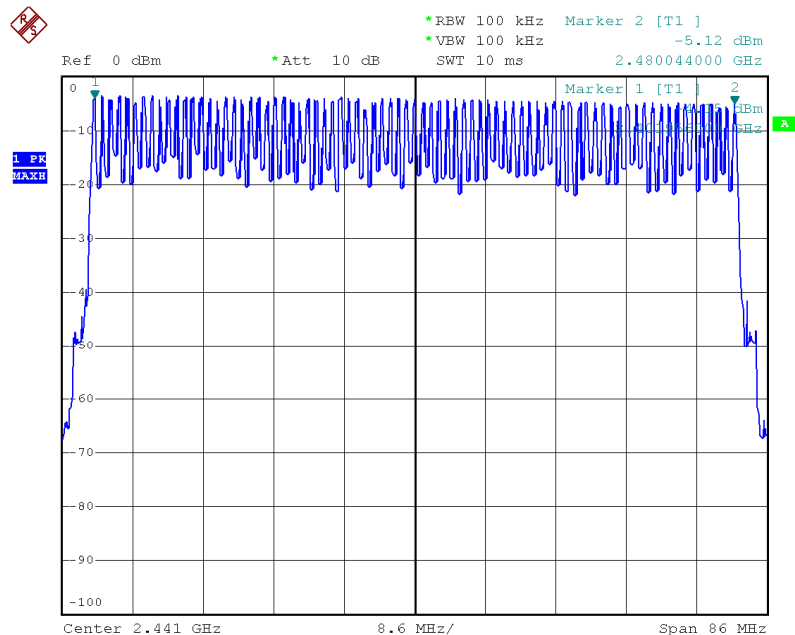

The results shown in this test report refer only to the sample(s) tested , This Test report cannot be reproduced, except in full, without prior written permission of the Company.

13 Dwell Time

Test Requirement:	FCC CFR47 Part 15 Section 15.247
Test Method:	Based on DA 00-705
Test Limit:	Regulation 15.247(a)(1)(iii) Frequency hopping systems in the 2400-2483.5 MHz band shall use at least 15 channels. The average time of occupancy on any channel shall not be greater than 0.4 seconds within a period of 0.4 seconds multiplied by the number of hopping channels employed.
Test Mode:	Test in hopping transmitting operating mode.

13.1 Test Procedure:

- 1.Remove the antenna from the EUT and then connect a low RF cable from the antenna port to the spectrum.
- 2.Set spectrum analyzer span = 0. centered on a hopping channel;
- 3.Set RBW = 1MHz and VBW = 1MHz.Sweep = as necessary to capture the entire dwell time per hopping channel.
- 4.Use the marker-delta function to determine the dwell time. If this value varies with different modes of operation (e.g.. data rate. modulation format. etc.). repeat this test for each variation. The limit is specified in one of the subparagraphs of this Section. Submit this plot(s).

13.2 Test Result:

Dwell time = Pulse wide x (Hopping rate / Number of channels) x Period

The test period: $T = 0.4(s) * 79 = 31.6 (s)$

DH5 Packet permit maximum $1600 / 79 / 6$ hops per second in each channel (5 time slots RX, 1 time slot TX).

DH3 Packet permit maximum $1600 / 79 / 4$ hops per second in each channel (3 time slots RX, 1 time slot TX).

DH1 Packet permit maximum $1600 / 79 / 2$ hops per second in each channel (1 time slot RX, 1 time slot TX). So,the Dwell Time can be calculated as follows:

Data Packet	Dwell Time(s)
DH5	$1600/79/6*31.6*(MkrDelta)/1000$
DH3	$1600/79/4*31.6*(MkrDelta)/1000$
DH1	$1600/79/2*31.6*(MkrDelta)/1000$

Note : Mkr Delta is once pulse time .

Low Channel: 2402MHz

Dwell time of each occupation in this channel as follows:

Data Packet	Frequency	Mkr Delta(ms)	Dwell Time(s)	Limits(s)	Result
DH5	2402 MHz	3.104	0.331	0.400	Pass
DH3	2402 MHz	1.798	0.288	0.400	Pass
DH1	2402 MHz	0.530	0.170	0.400	Pass

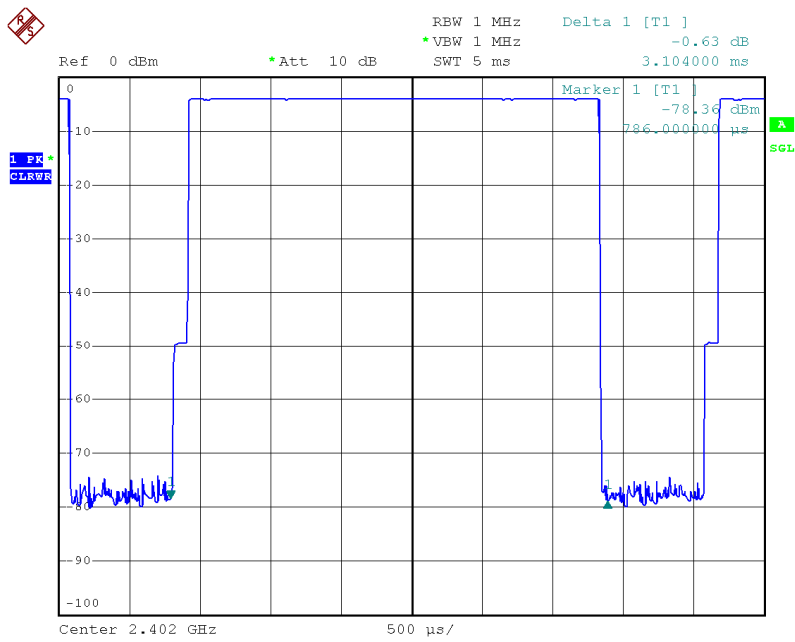

(DH5)

The results shown in this test report refer only to the sample(s) tested , This Test report cannot be reproduced, except in full, without prior written permission of the Company.

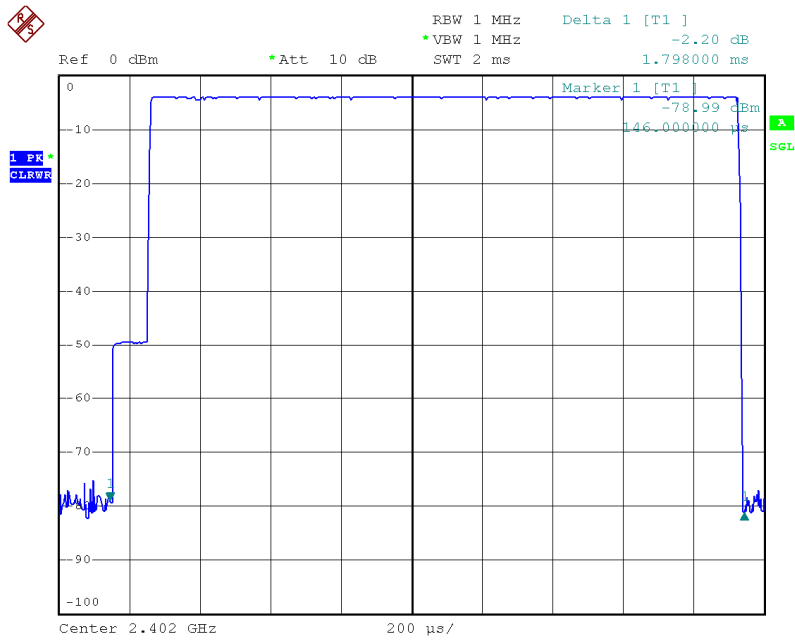

(DH3)

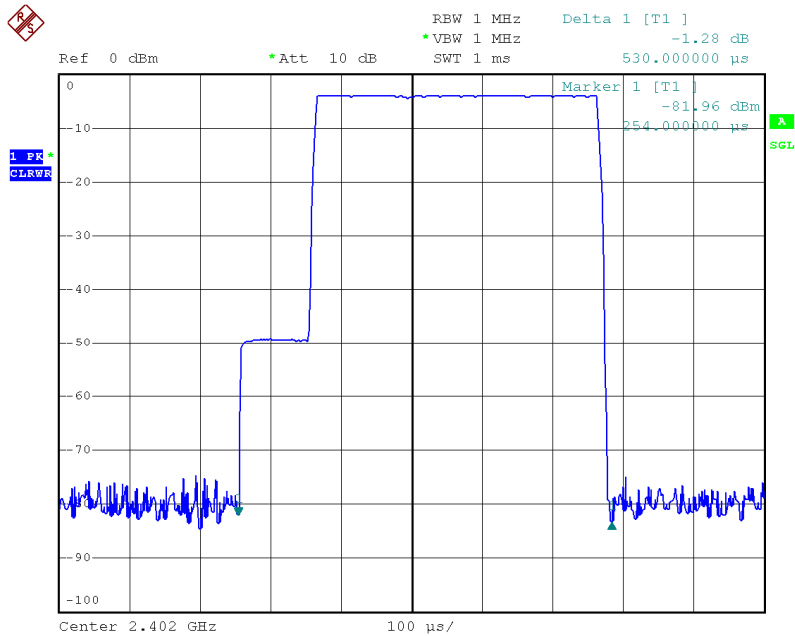

(DH1)

The results shown in this test report refer only to the sample(s) tested , This Test report cannot be reproduced, except in full, without prior written permission of the Company.

Middle Channel: 2441MHz

Dwell time of each occupation in this channel as follows:

Data Packet	Frequency	Mkr Delta(ms)	Dwell Time(s)	Limits(s)	Result
DH5	2441 MHz	3.080	0.329	0.400	Pass
DH3	2441 MHz	1.798	0.288	0.400	Pass
DH1	2441 MHz	0.530	0.170	0.400	Pass

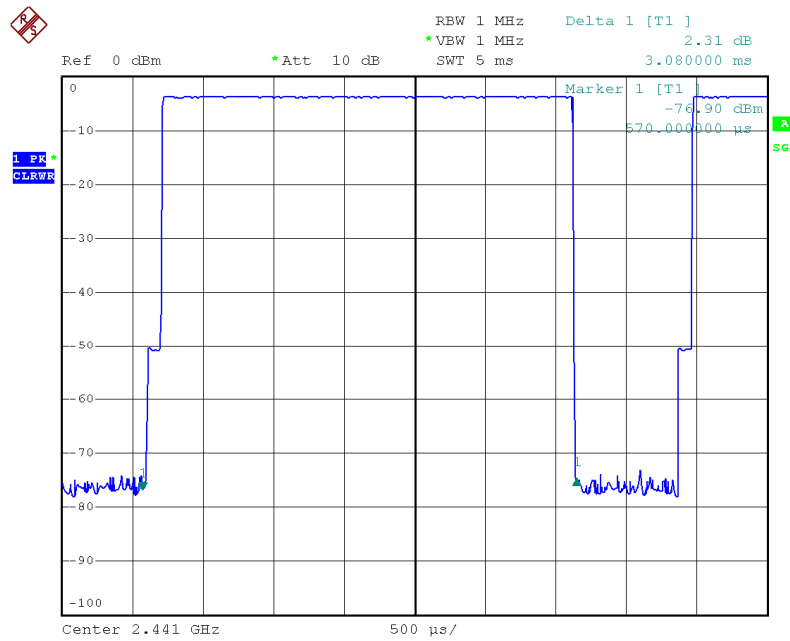

(DH5)

The results shown in this test report refer only to the sample(s) tested , This Test report cannot be reproduced, except in full, without prior written permission of the Company.

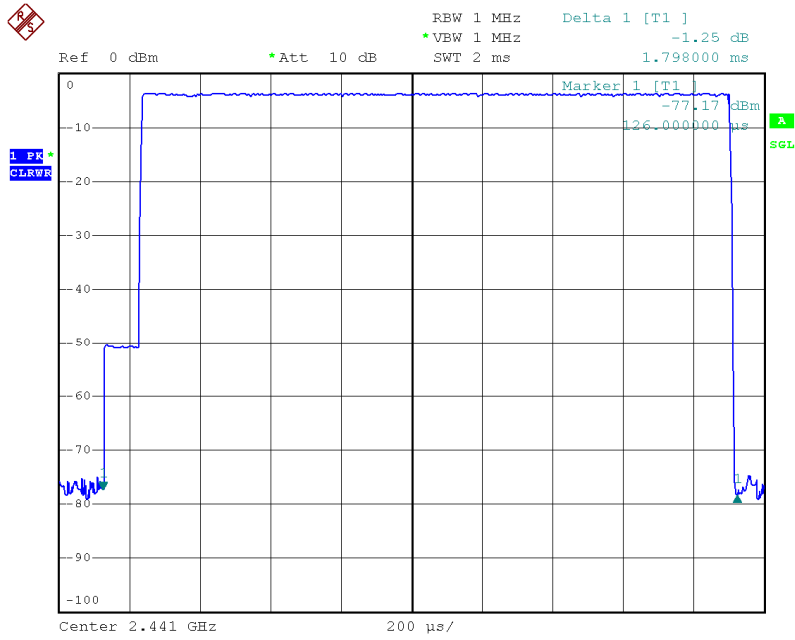

(DH3)

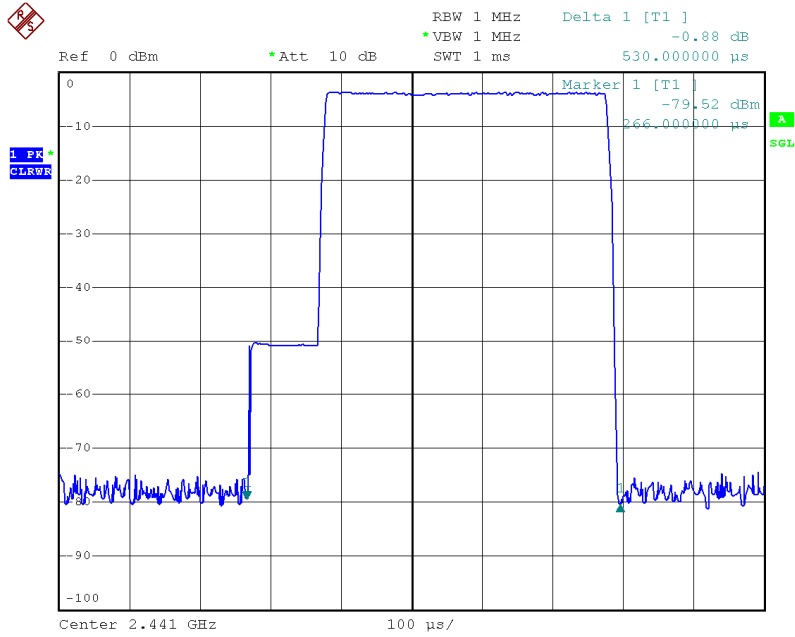

(DH1)

The results shown in this test report refer only to the sample(s) tested , This Test report cannot be reproduced, except in full, without prior written permission of the Company.

High Channel: 2480MHz

Dwell time of each occupation in this channel as follows:

Data Packet	Frequency	Mkr Delta(ms)	Dwell Time(s)	Limits(s)	Result
DH5	2480 MHz	3.052	0.326	DH5	Pass
DH3	2480 MHz	1.802	0.288	DH3	Pass
DH1	2480 MHz	0.534	0.171	DH1	Pass

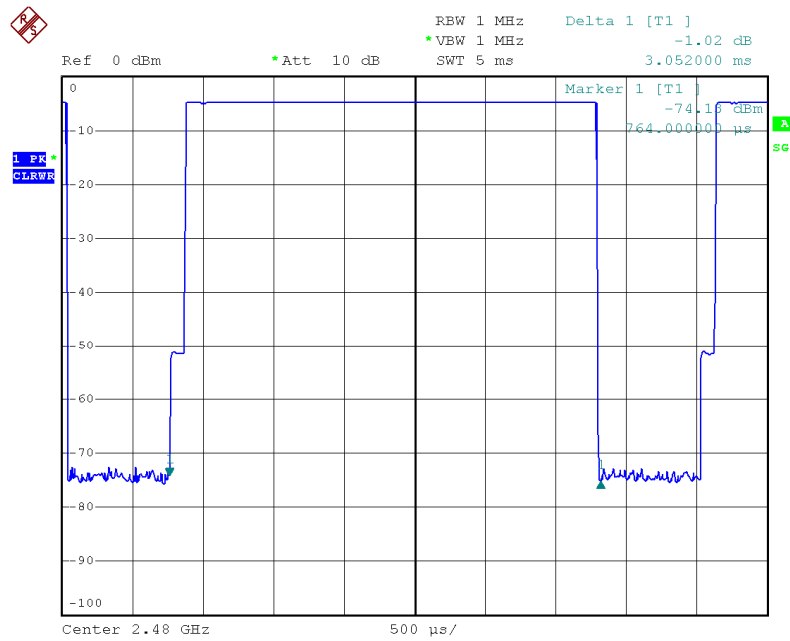

(DH5)

The results shown in this test report refer only to the sample(s) tested , This Test report cannot be reproduced, except in full, without prior written permission of the Company.

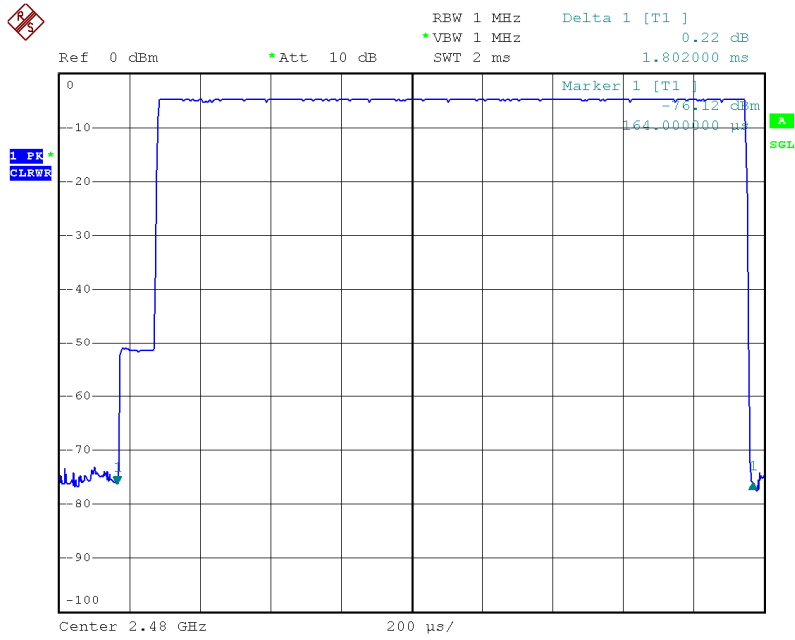

(DH3)

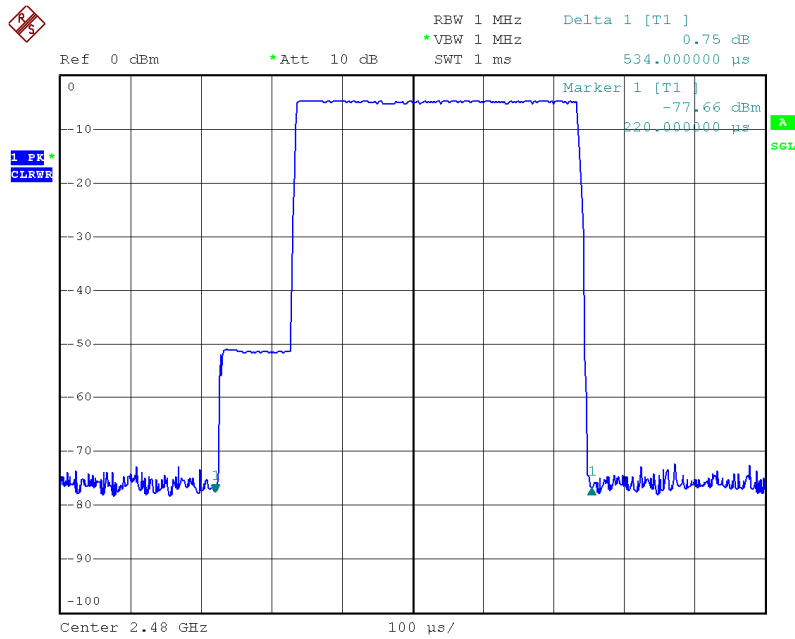

(DH1)

The results shown in this test report refer only to the sample(s) tested , This Test report cannot be reproduced, except in full, without prior written permission of the Company.

14 Antenna Requirement

According to the FCC Part 15 Paragraph 15.203, an intentional radiator shall be designed to ensure that no antenna other than that furnished by the responsible party shall be used with the device. The use of a permanently attached antenna or of an antenna that uses a unique coupling to the intentional radiator shall be considered sufficient to comply with the provisions of this section. This product has a permanent PCB antenna, fulfill the requirement of this section.

15 RF Exposure

Test Requirement: FCC Part 1.1307

Test Mode: The EUT work in test mode(Tx).

15.1 Requirments:

Systems operating under the provisions of this section shall be operated in a manner that ensures that the public is not exposed to radio frequency energy levels in excess limit for maximum permissible exposure. In accordance with 47 CFR FCC Part 2 Subpart J, section 2.1093 this device has been defined as a mobile device.

15.2 The procedures / limit

(A) Limits for Occupational / Controlled Exposure

Frequency Range (MHz)	Electric Field Strength (E) (V/m)	Magnetic Field Strength (H) (A/m)	Power Density (S) (mW/ cm ²)	Averaging Time E ² , H ² or S (minutes)
0.3-3.0	614	1.63	(100)*	6
3.0-30	1842 / f	4.89 / f	(900 / f)*	6
30-300	61.4	0.163	1.0	6
300-1500			F/300	6
1500-100,000			5	6

(B) Limits for General Population / Uncontrolled Exposure

Frequency Range (MHz)	Electric Field Strength (E) (V/m)	Magnetic Field Strength (H) (A/m)	Power Density (S) (mW/ cm ²)	Averaging Time E ² , H ² or S (minutes)
0.3-1.34	614	1.63	(100)*	30
1.34-30	824/f	2.19/f	(180/f)*	30
30-300	27.5	0.073	0.2	30
300-1500			F/1500	30
1500-100,000			1.0	30

Note: f = frequency in MHz ; *Plane-wave equivalent power density

15.3 MPE Calculation Method

$$E \text{ (V/m)} = \frac{\sqrt{30 \times P \times G}}{d} \quad \text{Power Density: } Pd \text{ (W/m}^2\text{)} = \frac{E^2}{377}$$

E = Electric field (V/m)

P = Peak RF output power (W)

G = EUT Antenna numeric gain (numeric)

d = Separation distance between radiator and human body (m)

The formula can be changed to

$$Pd = \frac{30 \times P \times G}{377 \times d^2}$$

From the peak EUT RF output power, the minimum mobile separation distance, d=0.2m, as well as the gain of the used antenna, the RF power density can be obtained

Antenna Gain (dBi)	Antenna Gain (numeric)	Peak Output Power (dBm)	Peak Output Power (mW)	Power Density (S) (mW/cm ²)	Limit of Power Density (S) (mW/cm ²)	Test Result
0	1	-3.27	0.4709	0.000094	1	Complies
0	1	-4.08	0.3908	0.000074	1	Complies
0	1	-4.92	0.3221	0.000064	1	Complies

The results shown in this test report refer only to the sample(s) tested , This Test report cannot be reproduced, except in full, without prior written permission of the Company.

16 Photographs - Constructional Details

16.1 Product View



Model: AIR01



Model: AIR02

16.2 EUT – Appearance View

Model: AIR01



The results shown in this test report refer only to the sample(s) tested , This Test report cannot be reproduced, except in full, without prior written permission of the Company.

WALTEK SERVICES

Reference No.: WT12075138-S-S-F



The results shown in this test report refer only to the sample(s) tested , This Test report cannot be reproduced, except in full, without prior written permission of the Company.

WALTEK SERVICES

Reference No.: WT12075138-S-S-F

Model: AIR01



The results shown in this test report refer only to the sample(s) tested , This Test report cannot be reproduced, except in full, without prior written permission of the Company.

WALTEK SERVICES

Reference No.: WT12075138-S-S-F



The results shown in this test report refer only to the sample(s) tested , This Test report cannot be reproduced, except in full, without prior written permission of the Company.

WALTEK SERVICES

Reference No.: WT12075138-S-S-F

16.3 EUT – Open View



16.4 EUT – PCB View

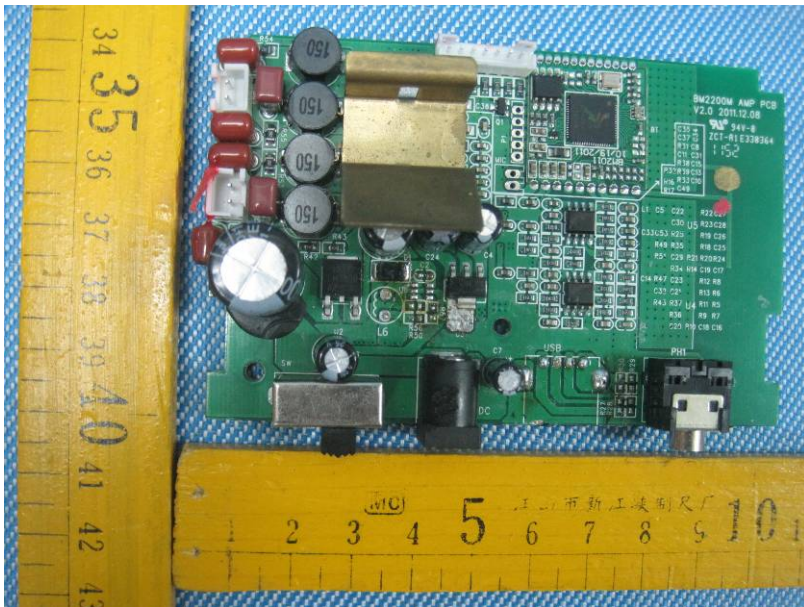

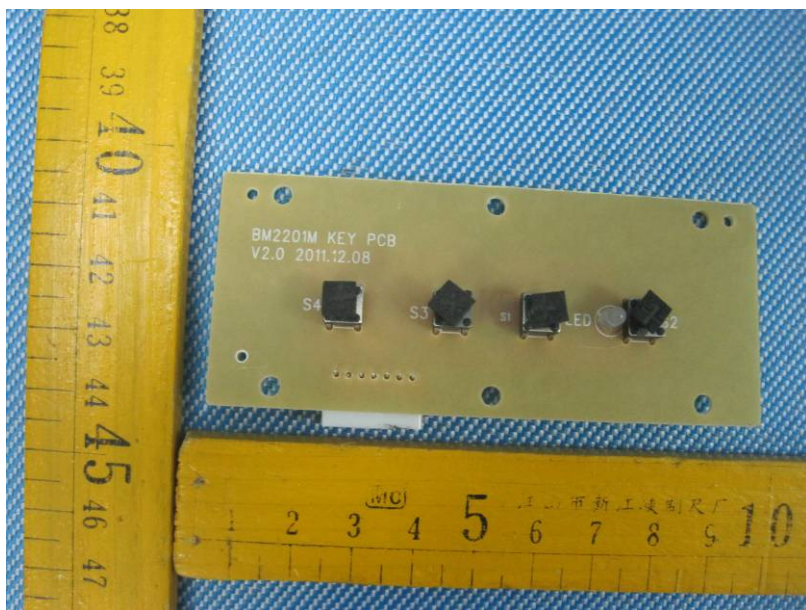
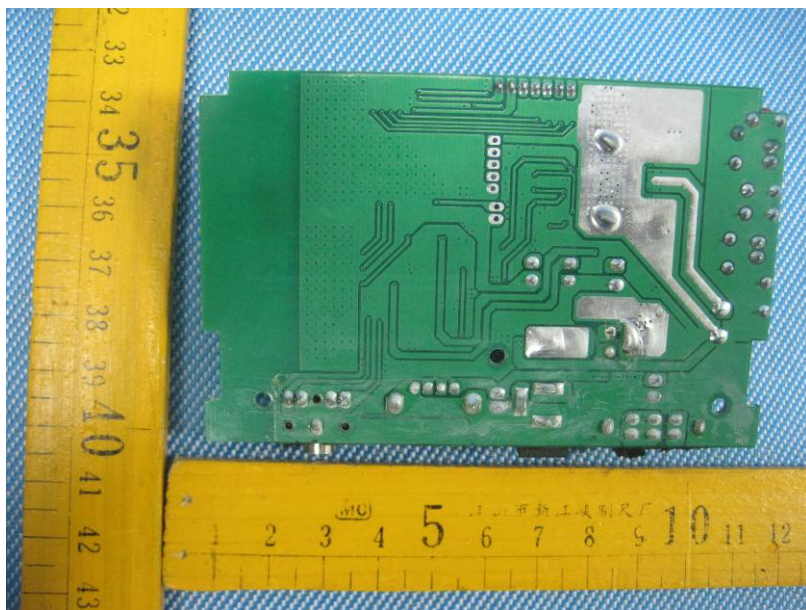

The results shown in this test report refer only to the sample(s) tested , This Test report cannot be reproduced, except in full, without prior written permission of the Company.

WALTEK SERVICES

Reference No.: WT12075138-S-S-F

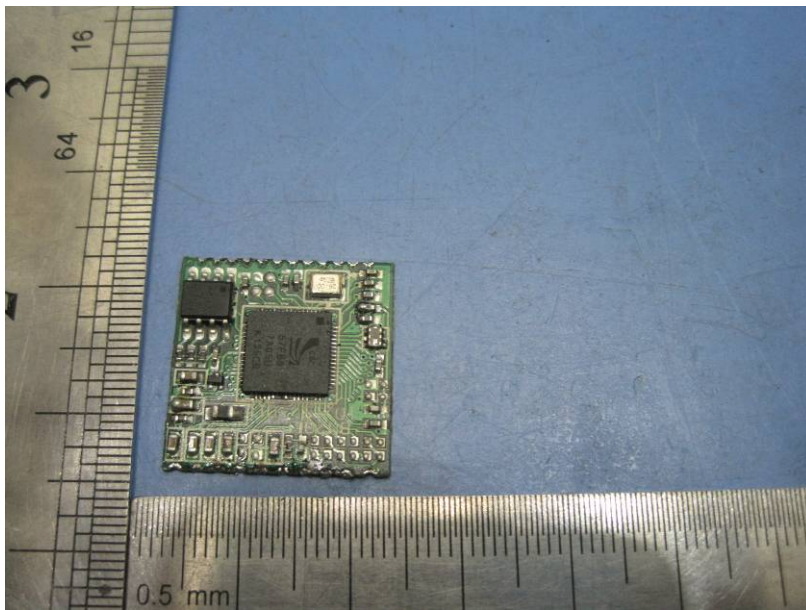
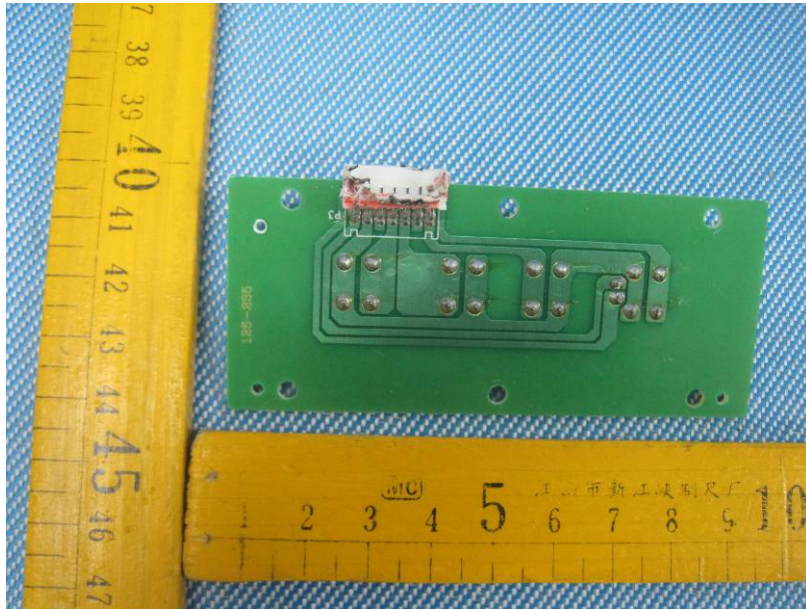

The results shown in this test report refer only to the sample(s) tested , This Test report cannot be reproduced, except in full, without prior written permission of the Company.

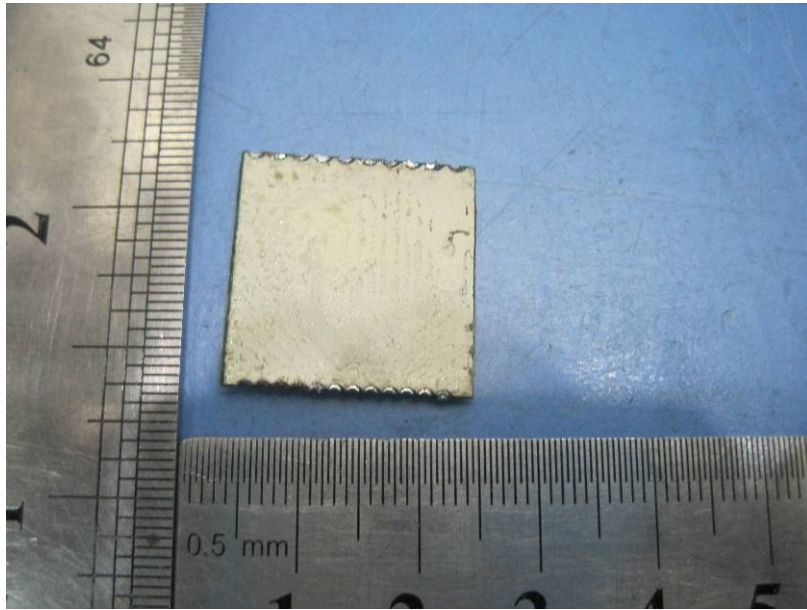

The results shown in this test report refer only to the sample(s) tested , This Test report cannot be reproduced, except in full, without prior written permission of the Company.

WALTEK SERVICES

Reference No.: WT12075138-S-S-F

17 FCC Label

This device complies with Part 15 of the FCC Rules. Operation is subject to the following two conditions:(1)this device may not cause harmful interference,and (2) this device must accept any interference received, including interference that may cause undesired operation

The Label must not be a stick-on paper. The Label on these products must be permanently affixed to the product and readily visible at the time of purchase and must last the expected lifetime of the equipment not be readily detachable.

Proposed Label Location on EUT
EUT Bottom View/ proposed FCC Label Location

