



Testing Tomorrow's Technology

Class 2 Permissive Change Test Report

For

Part 2, Subpart J, Paragraph 2.907 Equipment Authorization of Certification for an Intentional Radiator per Part 15, Subpart C, paragraphs 15.207, 15.209 and 15.247

And

RSS-247 Issue 2: Digital Transmission Systems (DTSs), Frequency Hopping Systems (FHSs) and License-Exempt Local Area Network (LE-LAN) Devices

For the

Neptune Technology Group, Inc.

Model: R900

**FCC ID: P2SR900CE
IC ID: 4171B-R900CE**

UST Project: 23-0195

Issue Date: October 17, 2023

Total Pages: 21

**3505 Francis Circle Alpharetta, GA 30004
PH: 770-740-0717 Fax: 770-740-1508
www.ustech-lab.com**



Testing Tomorrow's Technology

I certify that I am authorized to sign for the Test Agency and that all of the statements in this report and in the Exhibits attached hereto are true and correct to the best of my knowledge and belief:

US TECH (Agent Responsible For Test):

By: Alan Ghasiani

Name: Alan Ghasiani

Title: Compliance Engineer – President

Date: October 17, 2023



This report shall not be reproduced except in full. This report may be copied in part only with the prior written approval of US Tech. The results contained in this report are subject to the adequacy and representative character of the sample provided. This report must not be used to claim product certification, approval, or endorsement by NVLAP, NIST or any agency of the Federal Government.

3505 Francis Circle Alpharetta, GA 30004
PH : 770-740-0717 Fax : 770-740-1508
www.ustech-lab.com

US Tech Test Report:
FCC ID:
IC ID:
Test Report Number:
Issue Date:
Customer:
Model:

FCC Part 15 Class II Permissive Change
P2SR900CE
4171B-R900CE
23-0195
October 17, 2023
Neptune Technology Group, Inc.
R900

MEASUREMENT TECHNICAL REPORT

Company Name:	Neptune Technology Group, Inc.
Address:	1600 Alabama Hwy 229 Tallasse, AL 36078, USA
Model:	R900
FCC ID:	P2SR900CE
IC ID:	4171B-R900CE
Date:	October 17, 2023

This report concerns (check one): Original Class II Permissive Change

Equipment type: 900 MHz ISM Radio Transceiver

Technical Information:

Radio Technology:	FHSS
Frequency of Operation (MHz):	911.08 – 919.07
Output Power (dBm):	18.32
Type of Modulation:	OOK
Data/Bit Rate (M)bps:	1200 Baud
Antenna Gain (dBi):	Refer to Tables 5
Software used to program EUT:	PMIT v2.2.210208.74
EUT firmware:	2.4
Power setting:	248

Report prepared by:

US Tech

3505 Francis Circle Alpharetta, GA 30004

PH : 770-740-0717 Fax : 770-740-1508

www.ustech-lab.com

US Tech Test Report:
FCC ID:
IC ID:
Test Report Number:
Issue Date:
Customer:
Model:

FCC Part 15 Class II Permissive Change
P2SR900CE
4171B-R900CE
23-0195
October 17, 2023
Neptune Technology Group, Inc.
R900

Table of Contents

<u>Title</u>	<u>Page</u>
1 General Information	6
1.1 Purpose of this Report	6
1.2 Characterization of Test Sample	6
1.3 Product Description	6
1.4 Configuration of Tested System	6
1.5 Test Facility	7
1.6 Related Submittal(s)/Grant(s)	7
2 Tests and Measurements	10
2.1 Test Equipment	10
2.2 Modifications to EUT Hardware	10
2.3 Number of Measurements for Intentional Radiators (CFR 15.31(m))	11
2.4 Frequency Range of Radiated Measurements (CFR 15.33)	11
2.4.1 Intentional Radiator	11
2.4.2 Unintentional Radiator	11
2.5 Measurement Detector Function and Bandwidth (CFR 15.35)	12
2.5.1 Detector Function and Associated Bandwidth	12
2.5.2 Corresponding Peak and Average Requirements	12
2.5.3 Pulsed Transmitter Averaging	12
2.6 Transmitter Duty Cycle (Part 15.35(c))	13
2.7 Restricted Bands of Operation (Part 15.205)	13
2.8 EUT Antenna Requirements (CFR 15.203)	13
2.10 Intentional Radiator, Radiated Emissions (CFR 15.209, 15.247(d))	14
2.10.1 EUT Worst Case Test Configuration	14
2.12 Intentional Radiator Power Line Conducted Emissions (CFR 15.207)	17
2.13 Unwanted Emissions of the Intentional Radiator, (CFR 15.209 and 15.33(a))	17
2.14 Measurement Uncertainty	21
2.14.1 Conducted Emissions Measurement Uncertainty	21
2.14.2 Radiated Emissions Measurement Uncertainty	21
3 Test Results	21

US Tech Test Report:
FCC ID:
IC ID:
Test Report Number:
Issue Date:
Customer:
Model:

FCC Part 15 Class II Permissive Change
P2SR900CE
4171B-R900CE
23-0195
October 17, 2023
Neptune Technology Group, Inc.
R900

List of Figures

<u>Title</u>	<u>Page</u>
Figure 1. EUT Test Configuration Diagram	9
Figure 2. Radiated Emissions 30 MHz – 1000 MHz, Horizontal	19
Figure 3. Radiated Emissions 30 MHz – 1000 MHz, Vertical	19

List of Tables

<u>Title</u>	<u>Page</u>
Table 1. EUT and Peripherals	8
Table 2. Details of I/O Cables Attached to EUT	8
Table 3. Test Instruments	10
Table 4. Number of Test Frequencies for Intentional Radiators	11
Table 5. Antenna 1 (External Antenna)	13
Table 6. Peak Radiated Fundamental and Harmonic Emissions	15
Table 7. Average Radiated Fundamental and Harmonic Emissions	16
Table 8. Spurious Radiated Emissions (30 MHz – 1 GHz)	18
Table 9. Spurious Radiated Emissions (1 GHz – 9 GHz)	20

List of Attachments

FCC Agency Agreement
Application Forms
RF Exposure

External Photos
Test Configuration Photographs
Letter of Confidentiality

US Tech Test Report:
FCC ID:
IC ID:
Test Report Number:
Issue Date:
Customer:
Model:

FCC Part 15 Class II Permissive Change
P2SR900CE
4171B-R900CE
23-0195
October 17, 2023
Neptune Technology Group, Inc.
R900

1 General Information

1.1 Purpose of this Report

This report is prepared as a means of conveying test results and information concerning the suitability of this exact product for Class II Permissive Change certification as an intentional transmitter device and public distribution according to FCC Rules and Regulations Part 15, Section 247 and Industry Canada RSS-247. The EUT is now packaged with a new external antenna, new enclosure, and the removal of the internal loop antenna. See the C2PC letter for details. Due to this change, additional radiated emission testing was performed to determine compliance to a Class II Permissive Change. Information concerning the new antenna is found in Table 5 of this report.

1.2 Characterization of Test Sample

The samples used for testing were received by US Tech on October 17, 2023 in good operating condition.

1.3 Product Description

The Equipment under Test (EUT) is the Neptune Technology Group, Model R900. The EUT is a network endpoint that collects meter reading data from an encoder register. It then transmits the data for collection using LTE-M cellular technology. The collection data is stored and downloaded into the utility billing system for processing. The R900 cellular endpoint has three different options for covers so that it can be installed on a wall or in a pit application. It operates on the AT&T and FirstNet LTE-M networks and contains an FCC and ISED Certified LTE Module bearing FCC ID: RI7ME310G1WW and IC: 5131A-ME310G1WW.

1.4 Configuration of Tested System

The Test Sample was tested per *ANSI C63.10:2013, American National Standard of Procedures for Compliance Testing of Unlicensed Wireless Devices* for the intentional radiator aspect of the device and *ANSI C63.4:2014, Methods of Measurement of Low-Voltage Electrical and Electronic Equipment in the Range of 9 kHz to 40 GHz (2014)* for the unintentional radiator aspect of the device as well as FCC subpart B and C of Part 15 and per FCC KDB Publication number 558074 v05r02 for Digital Transmission Systems Operating Under section 15.247.

US Tech Test Report:
FCC ID:
IC ID:
Test Report Number:
Issue Date:
Customer:
Model:

FCC Part 15 Class II Permissive Change
P2SR900CE
4171B-R900CE
23-0195
October 17, 2023
Neptune Technology Group, Inc.
R900

Per FCC Parts 15.107 and 15.109, digital RF conducted and radiated emissions below 1 GHz were measured with the spectrum analyzer's resolution bandwidth (RBW) adjusted to 9 kHz and 120 kHz, respectively. All measurements performed above 1 GHz were made with a RBW of 1 MHz. All measurements are peak unless stated otherwise. The video filter associated with the spectrum analyzer was set to 3 times the RBW or as required per the standard throughout the evaluation process.

A list of EUT and Peripherals is found in Table 1 below. A block diagram of the tested system is shown in Figure 1. Test configuration photographs for spurious and fundamental emissions are provided in separate Appendices.

1.5 Test Facility

Testing was performed at US Tech's measurement facility at 3505 Francis Circle, Alpharetta, GA 30004. This site has been fully described and registered with the FCC. Its designation number is 186022. Additionally, this site has also been fully described and submitted to Industry Canada (IC), and has been approved under file number 9900A-1.

1.6 Related Submittal(s)/Grant(s)

The EUT is subject to the following FCC Equipment Authorizations:

- a) Certification under section 15.209 as an intentional transmitter.
- b) SDoC under 15.101 as a digital device.

US Tech Test Report:
 FCC ID:
 IC ID:
 Test Report Number:
 Issue Date:
 Customer:
 Model:

FCC Part 15 Class II Permissive Change
 P2SR900CE
 4171B-R900CE
 23-0195
 October 17, 2023
 Neptune Technology Group, Inc.
 R900

Table 1. EUT and Peripherals

EUT MANUFACTURER	MODEL NUMBER	SERIAL NUMBER	FCC/IC ID	CABLES P/D
EUT Neptune Technology Group.	R900	Engineering Sample	FCC ID: P2SR900CE IC: 4171B-R900CE	N/A
PERIPHERAL MANUFACTURER	MODEL NUMBER	SERIAL NUMBER	FCC/IC ID	CABLES P/D
2 AA Rechargeable Lithium Batteries Tenavolts	N/A	Engineering Sample	N/A	N/A
Test Fixture Neptune Technology Group	N/A	Engineering Sample	N/A	N/A
Antenna See antenna details	--	--	--	--

S= Shielded, U= Unshielded, P= Power, D= Data

Table 2. Details of I/O Cables Attached to EUT

DESCRIPTION OF CABLE	DETAILS OF CABLE			CABLE LENGTH
	Manufacturer	Part Number		
Antenna cable	Neptune Technology Group	Various		< 0.5 m
	Shield Type	Shield Termination	Back-shell	
	CND	CND	CND	

Shield Type

N/A = None
 F = Foil
 B = Braided
 2B = Double Braided
 CND = Could Not Determine

Shield Termination

N/A = None
 360 = 360 Degrees
 P = Pigtail/Drain Wire
 CND = Could Not Determine
 MU = Metal Unshielded

Back-shell

N/A = Not Applicable
 PS = Plastic Shielded
 PU = Plastic Unshielded
 MS = Metal Shielded

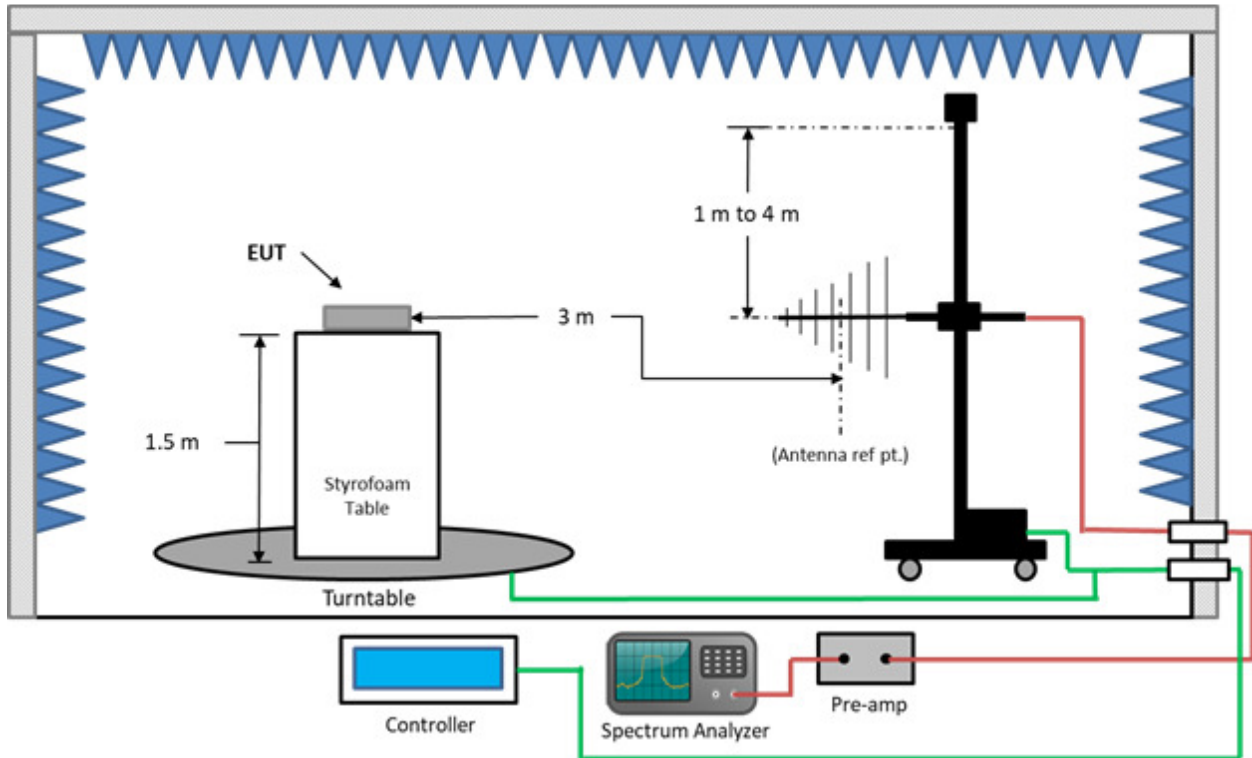

Figure 1. EUT Test Configuration Diagram

US Tech Test Report:
 FCC ID:
 IC ID:
 Test Report Number:
 Issue Date:
 Customer:
 Model:

FCC Part 15 Class II Permissive Change
 P2SR900CE
 4171B-R900CE
 23-0195
 October 17, 2023
 Neptune Technology Group, Inc.
 R900

2 Tests and Measurements

2.1 Test Equipment

The table below lists test equipment used to evaluate this product.

Table 3. Test Instruments

TEST INSTRUMENT	MODEL NUMBER	MANUFACTURER	SERIAL NUMBER	CALIBRATION DUE DATE
Spectrum Analyzer	E4404A	Agilent	MY45304803	7/21/2025 2 yr.
RF Preamp 100 kHz To 1.3 GHz	8447D	Hewlett-Packard	1937A01611	7/20/2024
Preamp 1.0 GHz To 26.0 GHz	8449B	Hewlett-Packard	3008A00914	3/3/2024
Biconical Antenna	3110B	EMCO	9307-1431	1/13/2025 2 yr.
Log Periodic Antenna	3146	EMCO	9110-3236	12/13/2023 2 yr
Horn Antenna	SAS-571	A.H. Systems	605	2/3/2023 2 yr.
High Pass Filter	VHF-1320 15542	Mini-Circuits, Inc.	3 0843	8/2/2024

Note: The calibration interval of the above test instruments are 12 months unless stated otherwise and all calibrations are traceable to NIST/USA.

2.2 Modifications to EUT Hardware

No modifications were made by US Tech to bring the EUT into compliance with FCC Part 15.247 and RSS-247 requirements.

2.3 Number of Measurements for Intentional Radiators (CFR 15.31(m))

Measurements of intentional radiators or receivers shall be performed and reported for each band in which the device can be operated, with the device operating at the number of frequencies in each band specified in Table 3 as follows:

Table 4. Number of Test Frequencies for Intentional Radiators

Frequency Range over which the device operates	Number of Frequencies	Location in the Range of operation
1 MHz or less	1	Middle
1 to 10 MHz	2	1 near the top 1 near the bottom
Greater than 10 MHz	3	1 near top 1 near middle 1 near bottom

The EUT operates over the range of 911.08 MHz to 919.07 MHz (7.99 MHz); therefore, two test frequencies were evaluated.

2.4 Frequency Range of Radiated Measurements (CFR 15.33)

2.4.1 Intentional Radiator

The spectrum shall be investigated for the intentional radiator from the lowest RF signal generated in the EUT, without going below 9 kHz to the 10th harmonic of the highest fundamental frequency generated or 40 GHz, whichever is the lowest.

2.4.2 Unintentional Radiator

For the digital device, an unintentional radiator, the frequency range shall be 30 MHz to 1000 MHz, or to the range specified in 2.4.1 above; whichever is the higher range of investigation.

US Tech Test Report:
FCC ID:
IC ID:
Test Report Number:
Issue Date:
Customer:
Model:

FCC Part 15 Class II Permissive Change
P2SR900CE
4171B-R900CE
23-0195
October 17, 2023
Neptune Technology Group, Inc.
R900

2.5 Measurement Detector Function and Bandwidth (CFR 15.35)

The radiated and conducted emissions limits shown herein are based on the parameters listed in the following paragraphs.

2.5.1 Detector Function and Associated Bandwidth

On frequencies below 1000 MHz, the limits herein are based upon measurement equipment employing a CISPR quasi-peak detector function and related measurement bandwidths (i.e. 9 kHz from 150 kHz to 30 MHz and 120 kHz from 30 MHz to 1000 MHz). Alternatively, measurements may be made with equipment employing a peak detector function as long as the same bandwidths specified for the quasi-peak device are used.

2.5.2 Corresponding Peak and Average Requirements

Above 1000 MHz, radiated limits are based on measuring instrumentation employing an average detector function. When average radiated emissions are specified there is also a corresponding peak requirement that is measured using a peak detector. The peak limit shall be 20 dB greater than the average limit. For all measurements above 1000 MHz, the Resolution Bandwidth shall be at least 1 MHz.

2.5.3 Pulsed Transmitter Averaging

When the radiated emissions limit is expressed as an average value, and the transmitter is pulsed, the measured field strength shall be determined by applying a Duty Cycle Correction Factor based upon dividing the total ON time during the first 100 ms period by 100 ms (or by the period if less than 100 ms). The duty cycle may also be expressed logarithmically in dB. In this case, the Duty Cycle Correction Factor was determined from the manufacturer's claim.

US Tech Test Report:
FCC ID:
IC ID:
Test Report Number:
Issue Date:
Customer:
Model:

FCC Part 15 Class II Permissive Change
P2SR900CE
4171B-R900CE
23-0195
October 17, 2023
Neptune Technology Group, Inc.
R900

2.6 Transmitter Duty Cycle (Part 15.35(c))

The Duty Cycle calculations are confidential and can be provided upon request by contacting Neptune Technology Group.

2.7 Restricted Bands of Operation (Part 15.205)

Only spurious emissions can fall in the frequency bands of CFR 15.205. The field strength of these emissions cannot exceed the limits of 15.209. Radiated harmonics and other spurious emissions are examined for this requirement see paragraph 2.10.

2.8 EUT Antenna Requirements (CFR 15.203)

An intentional radiator shall be designed to ensure that no antenna other than that furnished by the responsible party shall be used with the device. The use of a permanently attached antenna or of an antenna that uses a unique coupling to the intentional radiator shall be considered sufficient to comply with the provisions of this section. The antenna details are as follows:

Table 5. Antenna 1 (External Antenna)

Manufacturer	Model	Type	Gain (dBi)	Connector
Neptune Technology Group	Standard Plus Antenna	Pit Antenna	6.0	proprietary BNC twist-lock RF connector

US Tech Test Report:
FCC ID:
IC ID:
Test Report Number:
Issue Date:
Customer:
Model:

FCC Part 15 Class II Permissive Change
P2SR900CE
4171B-R900CE
23-0195
October 17, 2023
Neptune Technology Group, Inc.
R900

2.10 Intentional Radiator, Radiated Emissions (CFR 15.209, 15.247(d))

For radiated measurements, the EUT was set into a continuous transmission mode. Below 1 GHz, the RBW of the measuring instrument was set equal to 120 kHz. Peak measurements above 1 GHz were measured using a RBW = 1 MHz, with a VBW \geq 3 x RBW. For average measurements above 1 GHz, the emissions were measured using an average detector. The measurement of each signal detected was maximized by rotating the turntable 360° clockwise and counterclockwise and raising and lowering the receive antenna between 1 and 4 meters in height while monitoring the ever changing spectrum analyzer display with Trace A in the Max-Hold mode and Trace B in the Clear-Write mode for the largest signal visible. The emission from the EUT was measured and recorded when both maxima were simultaneously satisfied.

2.10.1 EUT Worst Case Test Configuration

On the test site, the EUT was placed on top of a polystyrene table 80 cm above the ground plane inside a semi-anechoic test chamber. The EUT was evaluated in each of its three axes (X/Y/Z) while transmitting on the channel that produced the highest output power for worst case condition. The position of the EUT determined to be worst case was with the EUT positioned along its X axis (top of EUT facing up). The worst case test results of the fundamental and harmonics are presented in the table below.

US Tech Test Report:
 FCC ID:
 IC ID:
 Test Report Number:
 Issue Date:
 Customer:
 Model:

FCC Part 15 Class II Permissive Change
 P2SR900CE
 4171B-R900CE
 23-0195
 October 17, 2023
 Neptune Technology Group, Inc.
 R900

Table 6. Peak Radiated Fundamental and Harmonic Emissions

Test: FCC Part 15.247 / 15.209								
Frequency (MHz)	Test Data (dBuV)	Additional Factor	AF+CL-PA (dB/m)	Corrected Results (dBuV/m)	Limits (dBuV/m)	Distance / Polarization	Margin (dB)	Detector
Low Channel								
911.08	90.31	--	25.49	115.80	--	3m./HORZ	--	PK
1822.16	66.47	--	-8.43	58.04	74.0	3.0m./HORZ	16.0	PK
2733.24	47.97	--	-4.80	43.17	74.0	3.0m./HORZ	30.8	PK
3644.33	48.32	--	-3.58	44.74	74.0	3.0m./HORZ	29.3	PK
4555.41	46.06	--	-0.75	45.31	74.0	3.0m./HORZ	28.7	PK
5466.49	46.96	--	2.59	49.55	74.0	3.0m./HORZ	24.5	PK
Note 1	--	--	--	--	--	--	--	--
High Channel								
919.07	89.61	--	24.46	114.07	--	3m./VERT	--	PK
1838.14	62.73	--	-8.31	54.42	74.0	3.0m./VERT	19.6	PK
2757.21	51.36	--	-4.91	46.45	74.0	3.0m./VERT	27.6	PK
3676.31	51.84	--	-3.38	48.46	74.0	3.0m./VERT	25.5	PK
4595.35	47.46	--	-0.80	46.66	74.0	3.0m./VERT	27.3	PK
5514.40	47.14	--	2.74	49.88	74.0	3.0m./VERT	24.1	PK
Note 1	--	--	--	--	--	--	--	--

Notes:

1. No other signals detected within 20 dB of specification limit. Harmonics investigated up to the 10th harmonic

Sample calculation at 911.08 MHz:

Magnitude of Measured Frequency	90.31	dBuV
+Additional Factor	0.00	dB
+Antenna Factor + Cable Loss - Amplifier Gain	24.49	dB/m
Corrected Result	115.80	dBuV/m

Test Date: October 16, 2023

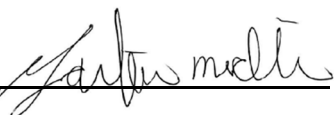
Signature: 

Test Engineer: Gabriel Medina

US Tech Test Report:
 FCC ID:
 IC ID:
 Test Report Number:
 Issue Date:
 Customer:
 Model:

FCC Part 15 Class II Permissive Change
 P2SR900CE
 4171B-R900CE
 23-0195
 October 17, 2023
 Neptune Technology Group, Inc.
 R900

Table 7. Average Radiated Fundamental and Harmonic Emissions

Test: FCC Part 15.247 / 15.209								
Frequency (MHz)	Test Data (dBuV)	Additional Factor	AF+CL-PA (dB/m)	Corrected Results (dBuV/m)	Limits (dBuV/m)	Distance / Polarity	Margin (dB)	Detector
Low Channel								
911.08	89.48	--	25.49	114.97	--	3m./HORZ	--	QP
1822.16	48.43	--	-8.43	40.00	54.0	3.0m./HORZ	14.0	AVG
2733.24	33.12	--	-4.80	28.32	54.0	3.0m./HORZ	25.7	AVG
3644.33	34.40	--	-3.58	30.82	54.0	3.0m./HORZ	23.2	AVG
4555.41	32.55	--	-0.75	31.80	54.0	3.0m./HORZ	22.2	AVG
5466.49	32.66	--	2.59	35.25	54.0	3.0m./HORZ	18.8	AVG
Note 1	--	--	--	--	--	--	--	--
High Channel								
919.07	89.30	--	24.46	113.76	--	3m./VERT	--	QP
1838.14	45.90	--	-8.31	37.59	54.0	3.0m./VERT	16.4	AVG
2757.21	35.51	--	-4.91	30.60	54.0	3.0m./VERT	23.4	AVG
3676.31	37.33	--	-3.38	33.95	54.0	3.0m./VERT	20.0	AVG
4595.35	33.27	--	-0.80	32.47	54.0	3.0m./VERT	21.5	AVG
5514.40	34.65	--	2.74	37.39	54.0	3.0m./VERT	16.6	AVG
Note 1	--	--	--	--	--	--	--	--

Notes:

1. No other signals detected within 20 dB of specification limit. Harmonics investigated up to the 10th harmonic.

Sample calculation at 911.08 MHz:

Magnitude of Measured Frequency	89.48	dBuV
+Additional Factor (Duty cycle correction)	0.00	dB
+Antenna Factor + Cable Loss - Amplifier Gain	25.49	dB/m
Corrected Result	114.97	dBuV/m

Test Date: October 16, 2023

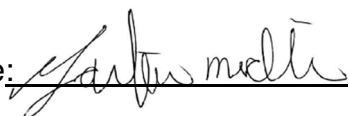
Signature: 

Test Engineer: Gabriel Medina

US Tech Test Report:
FCC ID:
IC ID:
Test Report Number:
Issue Date:
Customer:
Model:

FCC Part 15 Class II Permissive Change
P2SR900CE
4171B-R900CE
23-0195
October 17, 2023
Neptune Technology Group, Inc.
R900

2.12 Intentional Radiator Power Line Conducted Emissions (CFR 15.207)

The EUT is battery powered; therefore, this test is not applicable.

2.13 Unwanted Emissions of the Intentional Radiator, (CFR 15.209 and 15.33(a))

The test data provided herein is to support the verification requirement for unwanted radiated emissions coming from the EUT in a transmitting state per 15.209 and was investigated from 30 MHz to 9 GHz. The EUT was put into a co-located continuous transmit mode of operation and tested as detailed in ANSI C63.10:2013, Clause 6.4.6. Data is presented in the table below.

The measurement bandwidths for each frequency scan that was evaluated were set as follows:

Frequency Span	RBW / VBW
30 MHz – 1 GHz	120 kHz / 360 kHz
Above 1 GHz	1 MHz / 3 MHz

Note: Based on the changes made to the EUT, the device was only re-evaluated from 30 MHz to 1000 MHz. The emissions measurements seen were deemed to be equal to or less than what was previously recorded; therefore, no additional spurious emissions measurements were made beyond the measurements below.

US Tech Test Report:
 FCC ID:
 IC ID:
 Test Report Number:
 Issue Date:
 Customer:
 Model:

FCC Part 15 Class II Permissive Change
 P2SR900CE
 4171B-R900CE
 23-0195
 October 17, 2023
 Neptune Technology Group, Inc.
 R900

Table 8. Spurious Radiated Emissions (30 MHz – 1 GHz)

30 MHz to 1 GHz with Class B Limits Test: Radiated Emissions per CFR 15.209							
Frequency (MHz)	Test Data (dBuV)	AF+CL-PA (dB)	Results (dBuV/m)	Limits (dBuV/m)	Distance / Polarity	Margin (dB)	Detector PK / QP
86.20	32.95	-15.46	17.49	40.0	3m./HORZ	22.5	PK
565.20	33.80	-3.71	30.09	46.0	3m./HORZ	15.9	PK
834.05	36.79	-0.09	36.70	46.0	3m./HORZ	9.3	PK
31.35	39.21	-11.44	27.77	40.0	3m./VERT	12.2	PK
565.20	34.49	-5.21	29.28	46.0	3m./VERT	16.7	PK
872.40	40.63	-1.03	39.60	46.0	3m./VERT	6.4	PK

Test Date: October 16, 2023

Signature:  Test Engineer: Gabriel Medina

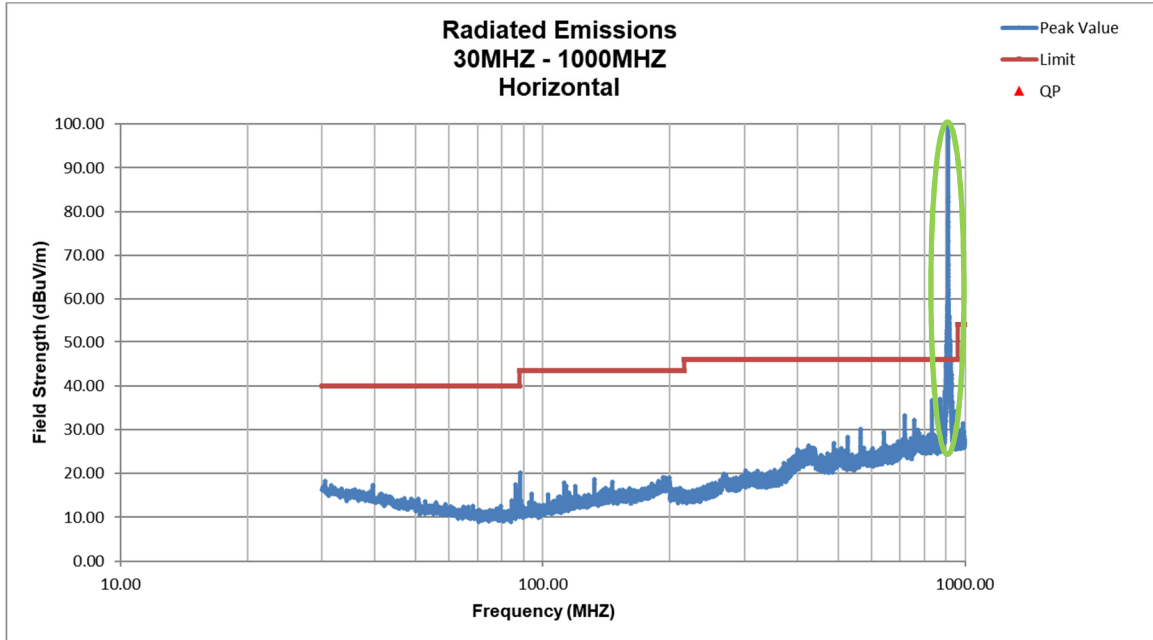

Figure 2. Radiated Emissions 30 MHz – 1000 MHz, Horizontal

Note: Circled in green is the fundamental of 900 MHz radio

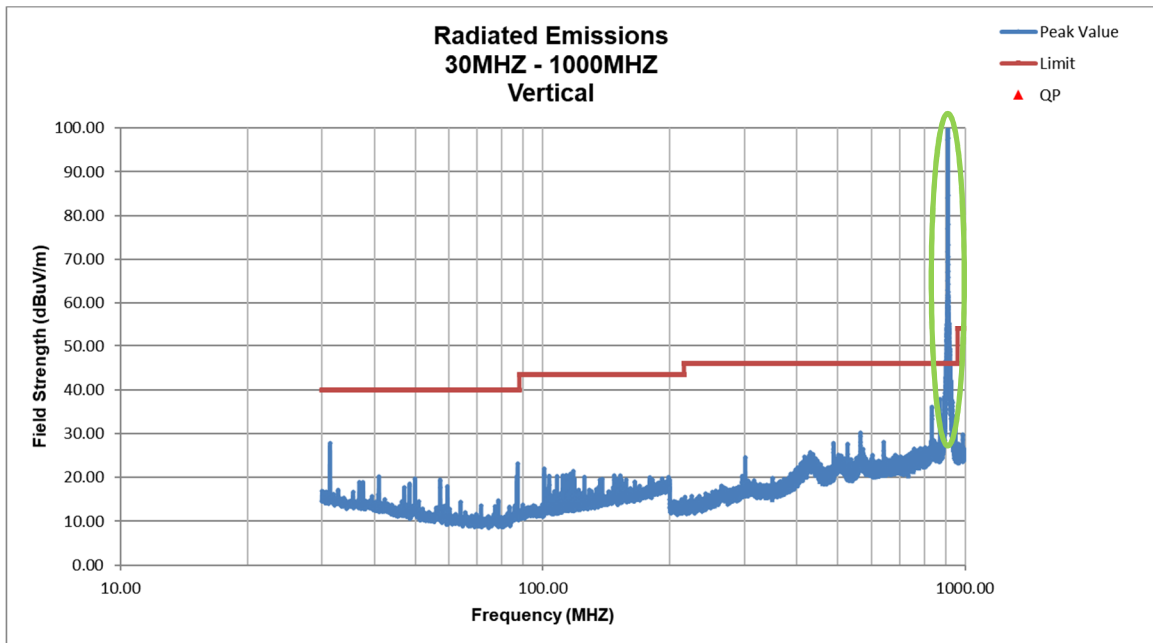

Figure 3. Radiated Emissions 30 MHz – 1000 MHz, Vertical

Note: Circled in green is the fundamental of 900 MHz radio

US Tech Test Report:
FCC ID:
IC ID:
Test Report Number:
Issue Date:
Customer:
Model:

FCC Part 15 Class II Permissive Change
P2SR900CE
4171B-R900CE
23-0195
October 17, 2023
Neptune Technology Group, Inc.
R900

Table 9. Spurious Radiated Emissions (1 GHz – 9 GHz)

1 GHz to 10 GHz with Class B Limits Test: Radiated Emissions per CFR 15.209							
Frequency (MHz)	Test Data (dBuV)	AF+CL-PA (dB)	Results (dBuV/m)	Limits (dBuV/m)	Distance / Polarization	Margin (dB)	Detector PK / AVG
No emissions other than harmonics of the fundamental frequency were detected.							

Test Date: October 16, 2023

Signature:  Test Engineer: Gabriel Medina

US Tech Test Report:
FCC ID:
IC ID:
Test Report Number:
Issue Date:
Customer:
Model:

FCC Part 15 Class II Permissive Change
P2SR900CE
4171B-R900CE
23-0195
October 17, 2023
Neptune Technology Group, Inc.
R900

2.14 Measurement Uncertainty

The measurement uncertainties given were calculated using the method detailed in CISPR 16-4-2:2011. A coverage factor of $k=2$ was used to give a level of confidence of approximately 95%.

2.14.1 Conducted Emissions Measurement Uncertainty

Measurement Uncertainty (within a 95% confidence level) for this test is ± 2.78 dB.

2.14.2 Radiated Emissions Measurement Uncertainty

For a measurement distance of 3 m the measurement uncertainty (with a 95% confidence level) for this test using a Biconical Antenna (30 MHz to 200 MHz) is ± 5.3 dB. This value includes all elements of measurement.

The measurement uncertainty (with a 95% confidence level) for this test using a Log Periodic Antenna (200 MHz to 1000 MHz) is ± 5.1 dB.

The measurement uncertainty (with a 95% confidence level) for this test using a Horn Antenna (Above 1000 MHz) is ± 5.1 dB.

3 Test Results

The EUT is deemed to have met the requirements of the standards cited within the test report when tested as detailed in the test report.