



Excellence in Compliance Testing

Certification Test Report

**FCC ID: P2SMRXV3
IC: 4171B-MRXV3**

**FCC Rule Part: 15.249
IC Radio Standards Specification: RSS-210**

ACS Report Number: 16-0202.W06.2A

**Manufacturer: Neptune Technology Group Inc.
Model: MRX920v3**

**Test Begin Date: May 24, 2016
Test End Date: June 2, 2016**

Report Issue Date: July 7, 2016



FOR THE SCOPE OF ACCREDITATION UNDER Certificate Number: AT-2021

This report must not be used by the client to claim product certification, approval, or endorsement by ANAB, NIST, or any agency of the Federal Government.

Prepared by:

**Ryan McGann
Wireless Program Manager
Advanced Compliance Solutions, Inc.**

Reviewed by:

**Thierry Jean-Charles
EMC Engineer
Advanced Compliance Solutions, Inc.**

This test report shall not be reproduced except in full. This report may be reproduced in part with prior written consent of ACS, Inc. The results contained in this report are representative of the sample(s) submitted for evaluation.

This report contains 19 pages

TABLE OF CONTENTS

1	GENERAL	3
1.1	PURPOSE.....	3
1.2	PRODUCT DESCRIPTION.....	3
1.3	TEST METHODOLOGY AND CONSIDERATIONS	4
2	TEST FACILITIES.....	5
2.1	LOCATION	5
2.2	LABORATORY ACCREDITATIONS/RECOGNITIONS/CERTIFICATIONS	5
2.3	RADIATED EMISSIONS TEST SITE DESCRIPTION	6
2.3.1	<i>Semi-Anechoic Chamber Test Site.....</i>	<i>6</i>
2.3.2	<i>Open Area Tests Site (OATS)</i>	<i>7</i>
2.4	CONDUCTED EMISSIONS TEST SITE DESCRIPTION	8
3	APPLICABLE STANDARD REFERENCES.....	8
4	LIST OF TEST EQUIPMENT.....	9
5	SUPPORT EQUIPMENT.....	10
6	EQUIPMENT UNDER TEST SETUP BLOCK DIAGRAM	10
7	SUMMARY OF TESTS.....	11
7.1	ANTENNA REQUIREMENT – FCC 15.203	11
7.2	POWER LINE CONDUCTED EMISSIONS – FCC 15.207, IC: RSS-GEN 8.8	11
7.3	20dB / 99% BANDWIDTH – FCC 15.215; IC RSS-GEN 4.6.....	11
7.3.1	<i>Measurement Procedure.....</i>	<i>11</i>
7.3.2	<i>Measurement Results</i>	<i>11</i>
7.4	FUNDAMENTAL FIELD STRENGTH – FCC 15.249(A); IC RSS-210 A2.9(A).....	15
7.4.1	<i>Measurement Procedure.....</i>	<i>15</i>
7.4.2	<i>Measurement Results</i>	<i>15</i>
7.5	RADIATED SPURIOUS EMISSIONS – FCC 15.249(A)(D)(E); IC RSS-210 A2.9(A)(B).....	16
7.5.1	<i>Measurement Procedure.....</i>	<i>16</i>
7.5.2	<i>Duty Cycle Correction.....</i>	<i>16</i>
7.5.3	<i>Measurement Results</i>	<i>17</i>
7.5.4	<i>Sample Calculation:</i>	<i>18</i>
8	CONCLUSION.....	19

1 GENERAL

1.1 Purpose

The purpose of this report is to demonstrate compliance with Part 15 Subpart C of the FCC's Code of Federal Regulations and Industry Canada's Radio Standards Specification RSS-210 Certification.

1.2 Product Description

The MRX920v3 is a 910-920MHz transceiver that is used in a motor vehicle to read wireless water meters manufactured by Neptune Technology Group and 3rd-party manufacturers. The MRX920v3 also contains a low-power Bluetooth Transceiver to allow a computing device to stream or download meter readings.

This report addresses the Bluetooth Transceiver only.

Technical Information:

Modulation	Frequency Range (MHz)	Number of Channels	Channel Separation (kHz)	Data Rate (Mbps)
GFSK	2402 - 2480	79	1000	1
$\pi/4$ -DQPSK	2402 - 2480	79	1000	2
8DPSK	2402 - 2480	79	1000	3

Antenna Type/Gain: Chip Antenna, 1.3 dBi gain
Operating Voltage: 12V

Manufacturer Information:
Neptune Technology Group Inc.
1600 Alabama Highway 229
Tallasse, AL 36078

EUT Serial Numbers: Prototype #10

Test Sample Condition: The test samples were provided in good working order with no visible defects.

1.3 Test Methodology and Considerations

All modes of operation, including all available data rates, were evaluated for each mode. The data presented in this report represents the worst case where applicable.

For radiated emissions the EUT was evaluated in three orthogonal orientations. The worst case orientation for fundamental field strength and radiated band edge was Y-orientation. The worst case orientation for radiated spurious emissions was Z-orientation. See the test setup photos for more information.

The EUT is designed to be used exclusively in a vehicle, therefore AC power line conducted emissions was not performed.

Radiated inter-modulation testing was performed for all combinations of simultaneous transmission and found to be in compliance.

2 TEST FACILITIES

2.1 Location

The radiated and conducted emissions test sites are located at the following address:

Advanced Compliance Solutions
5015 B.U. Bowman Drive
Buford, GA 30518
Phone: (770) 831-8048
Fax: (770) 831-8598

2.2 Laboratory Accreditations/Recognitions/Certifications

ACS is accredited to ISO/IEC 17025 by the ANSI-ASQ National Accreditation Board/ANAB accreditation program, and has been issued certificate number AT-2021 in recognition of this accreditation. Unless otherwise specified, all tests methods described within this report are covered under the ISO/IEC 17025 scope of accreditation.

The Semi-Anechoic Chamber Test Site, Open Area Test Site (OATS) and Conducted Emissions Site have been fully described, submitted to, and accepted by the FCC, Industry Canada and the Japanese Voluntary Control Council for Interference by information technology equipment.

FCC Registration Number: 391271
Industry Canada Lab Code: IC 4175A
VCCI Member Number: 1831

- VCCI OATS Registration Number R-1526
- VCCI Conducted Emissions Site Registration Number: C-1608

2.3 Radiated Emissions Test Site Description

2.3.1 Semi-Anechoic Chamber Test Site

The Semi-Anechoic Chamber Test Site consists of a 20' x 30' x 18' shielded enclosure. The chamber is lined with Toyo Ferrite Grid Absorber, model number FFG-1000. The ferrite tile grid is 101 x 101 x 19mm thick and weighs approximately 550 grams. These tiles are mounted on steel panels and installed directly on the inner walls of the chamber.

The turntable is 150cm in diameter and is located 160cm from the back wall of the chamber. The chamber is grounded via 1 - 8' copper ground rod, installed at the center of the back wall, it is bound to the ground plane using 3/4" stainless steel braided cable.

The turntable is all steel, flush mounted table installed in an all steel frame. The table is remotely operated from inside the control room located 25' from the range. The turntable is electrically bonded to the surrounding ground plane via steel fingers installed on the edge of the turn table. The steel fingers make constant contact with the ground plane during operation.

Behind the turntable is a 3' x 6' x 4' deep shielded pit used for support equipment if necessary. The pit is equipped with 1 - 4" PVC chases from the turntable to the pit that allow for cabling to the EUT if necessary. The underside of the turntable can be accessed from the pit so cables can be supplied to the EUT from the pit.

A diagram of the Semi-Anechoic Chamber Test Site is shown in Figure 2.3-1 below:

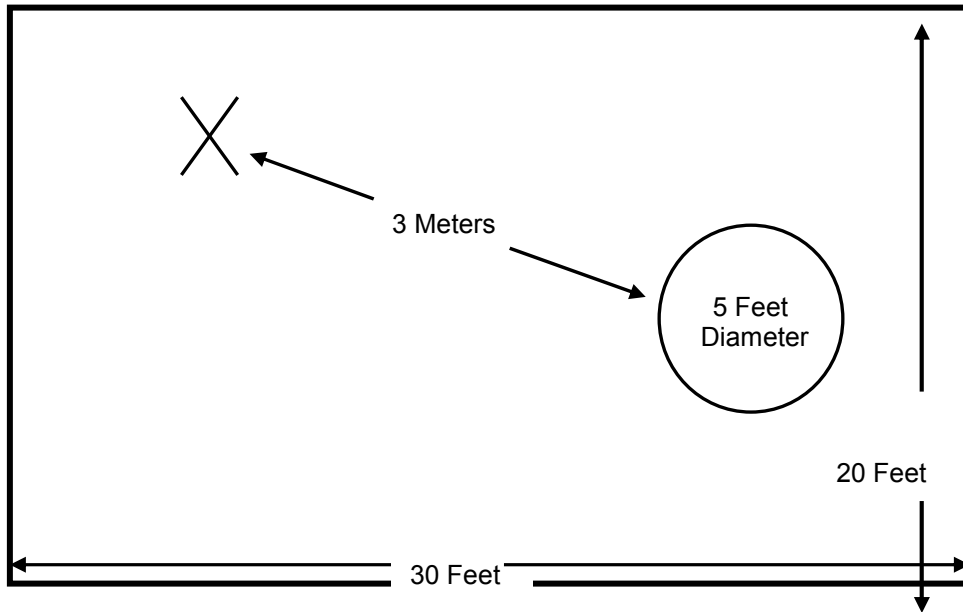

Figure 2.3-1: Semi-Anechoic Chamber Test Site

2.3.2 Open Area Tests Site (OATS)

The open area test site consists of a 40' x 66' concrete pad covered with a perforated electro-plated galvanized sheet metal. The perforations in the sheet metal are 1/8" holes that are staggered every 3/16". The individual sheets are placed to overlap each other by 1/4" and are riveted together to provide a continuous seam. Rivets are spaced every 3" in a 3 x 20 meter perimeter around the antenna mast and EUT area. Rivets in the remaining area are spaced as necessary to properly secure the ground plane and maintain the electrical continuity.

The entire ground plane extends 12' beyond the turntable edge and 16' beyond the antenna mast when set to a 10 meter measurement distance. The ground plane is grounded via 4 - 8' copper ground rods, each installed at a corner of the ground plane and bound to the ground plane using 3/4" stainless steel braided cable.

The turntable is an all aluminum 10' flush mounted table installed in an all aluminum frame. The table is remotely operated from inside the control room located 40' from the range. The turntable is electrically bonded to the surrounding ground plane via steel fingers installed on the edge of the turn table. The steel fingers make constant contact with the ground plane during operation.

Adjacent to the turntable is a 7' x 7' square and 4' deep concrete pit used for support equipment if necessary. The pit is equipped with 5 - 4" PVC chases from the pit to the control room that allow for cabling to the EUT if necessary. The underside of the turntable can be accessed from the pit so cables can be supplied to the EUT from the pit. The pit is covered with 2 sheets of 1/4" diamond style re-enforced steel sheets. The sheets are painted to match the perforated steel ground plane; however the underside edges have been masked off to maintain the electrical continuity of the ground plane. All reflecting objects are located outside of the ellipse defined in ANSI C63.4.

A diagram of the Open Area Test Site is shown in Figure 2.3-2 below:

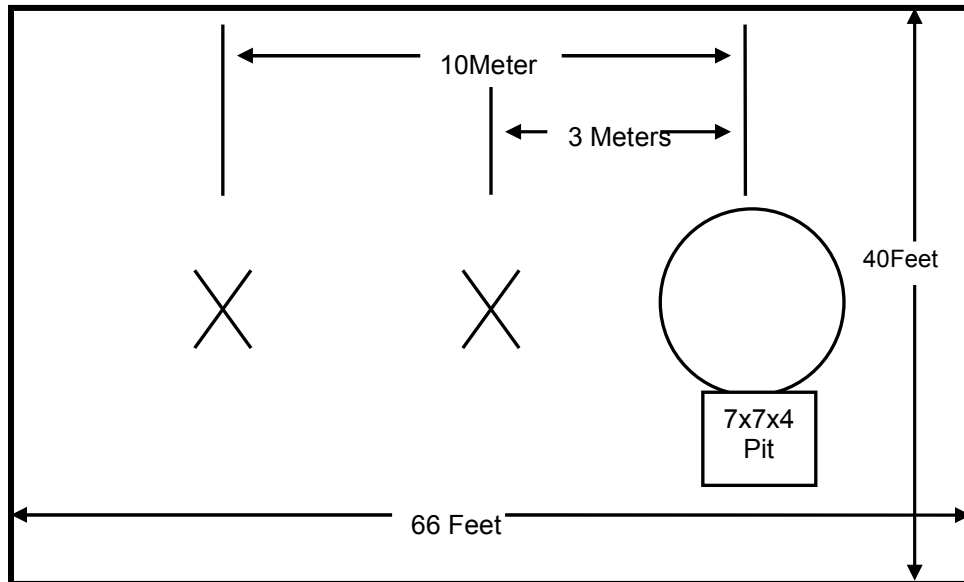

Figure 2.3-2: Open Area Test Site

2.4 Conducted Emissions Test Site Description

The AC mains conducted EMI site is located in the main EMC lab. It consists of an 8' x 8' solid aluminum horizontal ground reference plane (GRP) bonded every 3" to an 8' X 8' vertical ground plane.

The site is of sufficient size to test table top and floor standing equipment in accordance with section 6.1.4 of ANSI C63.10.

A diagram of the room is shown below in figure 4.1.3-1:

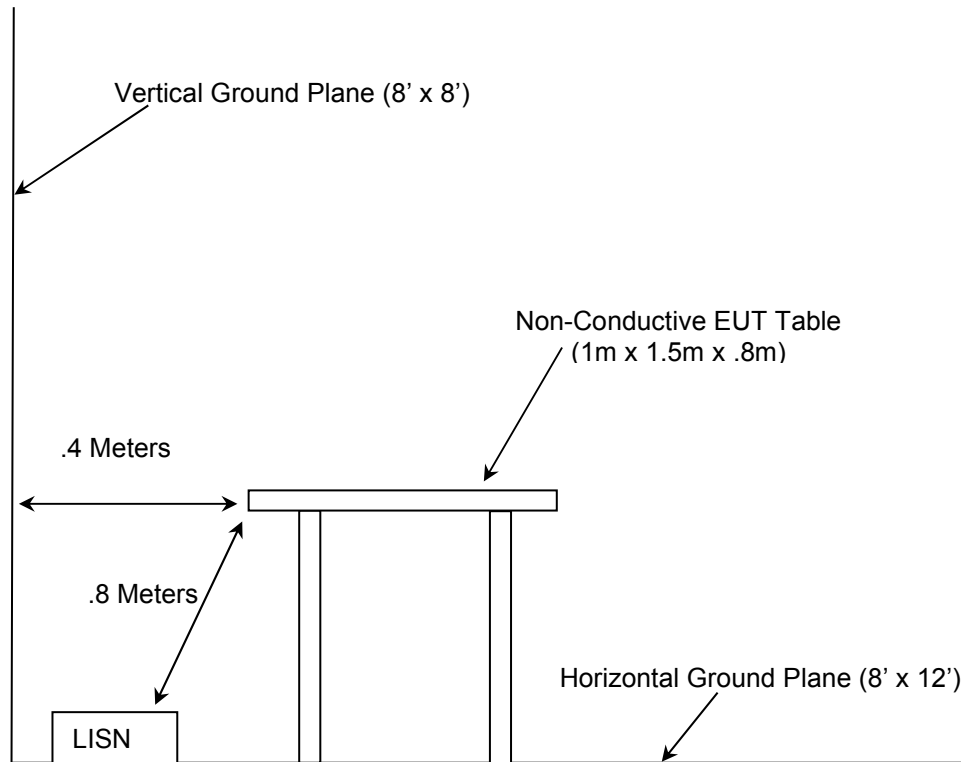

Figure 2.4-1: AC Mains Conducted EMI Site

3 APPLICABLE STANDARD REFERENCES

The following standards were used:

- ❖ ANSI C63.10-2013: American National Standard of Procedures for Compliance Testing of Unlicensed Wireless Devices
- ❖ US Code of Federal Regulations (CFR): Title 47, Part 2, Subpart J: Equipment Authorization Procedures, 2016
- ❖ US Code of Federal Regulations (CFR): Title 47, Part 15, Subpart C: Radio Frequency Devices, Intentional Radiators, 2016
- ❖ FCC KDB 558074 D01 DTS Meas Guidance v03r04 - Guidance for Performing Compliance Measurements on Digital Transmission Systems (DTS) Operating Under §15.247, January 7, 2016
- ❖ Industry Canada Radio Standards Specification: RSS-210 – Licence-exempt Radio Apparatus (All Frequency Bands): Category I Equipment, Issue 8, Dec 2010.
- ❖ Industry Canada Radio Standards Specification: RSS-GEN – General Requirements and Information for the Certification of Radiocommunication Equipment, Issue 4, Nov 2014.

4 LIST OF TEST EQUIPMENT

The calibration interval of test equipment is annually or the manufacturer's recommendations. Where the calibration interval deviates from the annual cycle based on the instrument manufacturer's recommendations, it shall be stated below.

Table 4-1: Test Equipment

AssetID	Manufacturer	Model #	Equipment Type	Serial #	Last Calibration Date	Calibration Due Date
1	Rohde & Schwarz	ESMI - Display	Spectrum Analyzers	833771/007	7/14/2015	7/14/2016
2	Rohde & Schwarz	ESMI-Receiver	Spectrum Analyzers	839587/003	7/14/2015	7/14/2016
30	Spectrum Technologies	DRH-0118	Antennas	970102	4/30/2015	4/30/2017
40	EMCO	3104	Antennas	3211	2/10/2015	2/10/2017
73	Agilent	8447D	Amplifiers	2727A05624	7/15/2015	7/15/2016
167	ACS	Hammer EMI Cable S	Cable Set	167	10/20/2015	10/20/2016
267	Agilent	N1911A	Meters	MY45100129	8/24/2015	8/24/2017
268	Agilent	N1921A	Sensors	MY45240184	8/13/2015	8/13/2017
292	Florida RF Cables	SMR-290AW-480.0-SMR	Cables	None	2/17/2016	2/17/2017
337	Microwave Circuits	H1G513G1	Filters	282706	5/13/2016	5/13/2017
338	Hewlett Packard	8449B	Amplifiers	3008A01111	8/21/2015	8/21/2017
340	Aeroflex/Weinschel	AS-20	Attenuators	7136	7/13/2015	7/13/2016
412	Electro Metrics	LPA-25	Antennas	1241	7/24/2014	7/24/2016
422	Florida RF	MS-200AW-72.0-SN	Cables	805	10/30/2015	10/30/2016
616	Florida RF Cables	SMRE-200W-12.0	Cables	N/A	9/3/2015	9/3/2016
622	Rohde & Schwarz	FSV40	Analyzers	101338	7/15/2015	7/15/2016

5 SUPPORT EQUIPMENT

Table 5-1: Support Equipment

Item	Equipment Type	Manufacturer	Model Number	Serial Number
1	Battery	Duralast	24MD-DL	N/A
2	Antenna	Laird	B8965C	N/A

6 EQUIPMENT UNDER TEST SETUP BLOCK DIAGRAM

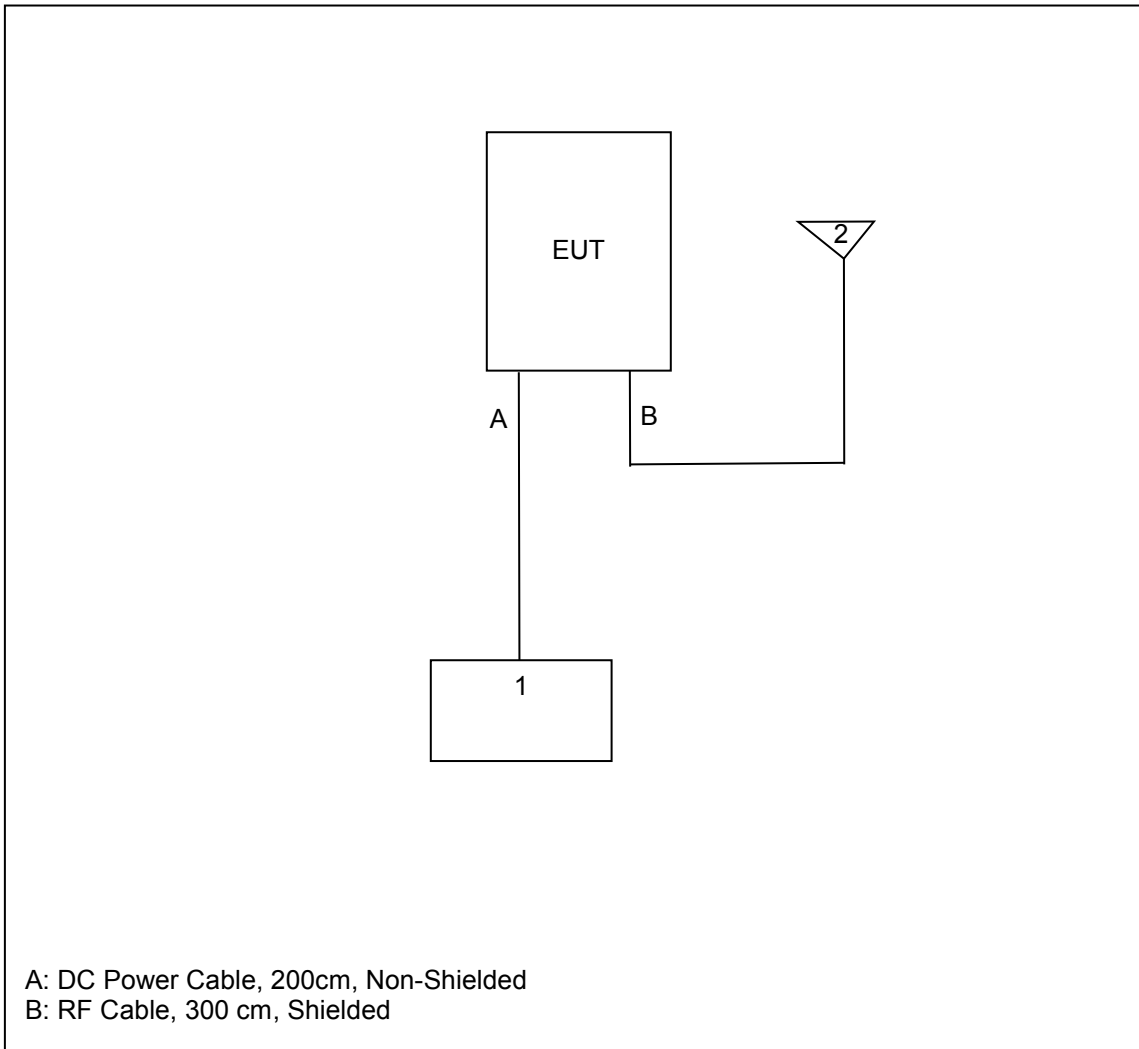

Figure 6-1: Test Setup Block Diagram

7 SUMMARY OF TESTS

Along with the tabular data shown below, plots were taken of all signals deemed important enough to document.

7.1 Antenna Requirement – FCC 15.203

The antenna is a non-detachable chip antenna with 1.3dBi gain. The antenna is permanently attached to the radio, therefore satisfying the requirements of 15.203.

7.2 Power Line Conducted Emissions – FCC 15.207, IC: RSS-Gen 8.8

The EUT is designed for operation exclusively in an automobile and not connected to the public AC mains, therefore power line conducted emissions was not performed.

7.3 20dB / 99% Bandwidth – FCC 15.215; IC RSS-Gen 6.6

7.3.1 Measurement Procedure

The span of the spectrum analyzer display was set between two times and five times the occupied bandwidth (OBW) of the emission. The RBW of the spectrum analyzer was set to approximately 1 % to 5 % of the OBW. The trace was set to max hold with a peak detector active. The Delta function of the analyzer was utilized to determine the 20 dB bandwidth of the emission.

The occupied bandwidth measurement function of the analyzer was used for the 99% bandwidth. The span of the analyzer shall be set to capture all products of the modulation process, including the emission skirts. The resolution bandwidth was set to 1% to 5% of the occupied bandwidth. The video bandwidth was set to 3 times the resolution bandwidth. A peak detector was used.

7.3.2 Measurement Results

Table 7.3.2-1: 20dB / 99% Bandwidth

Frequency (MHz)	20dB Bandwidth (kHz)	99% Bandwidth (kHz)	Modulation	Data Rate (Mbps)
2402	827.41	879.63	GFSK	1
2441	835.47	835.76		
2480	827.51	838.19		
2402	1185.34	1208.12	$\pi/4$ -DQPSK	2
2441	1175.87	1179.81		
2480	1176.99	1161.43		
2402	1183.93	1161.24	8DPSK	3
2441	1186.46	1171.56		
2480	1184.68	1136.59		

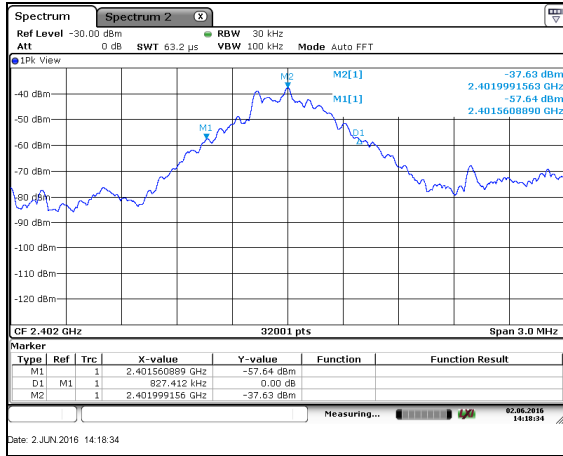

Figure 7.3.2-1: 20dB BW Low CH (GFSK - 1Mbps)

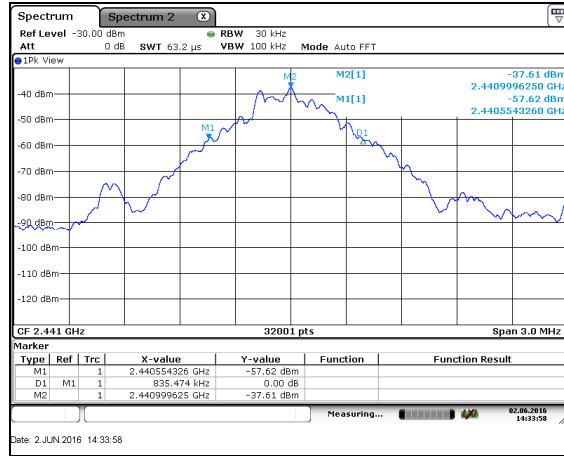

Figure 7.3.2-2: 20dB BW Mid CH (GFSK - 1Mbps)

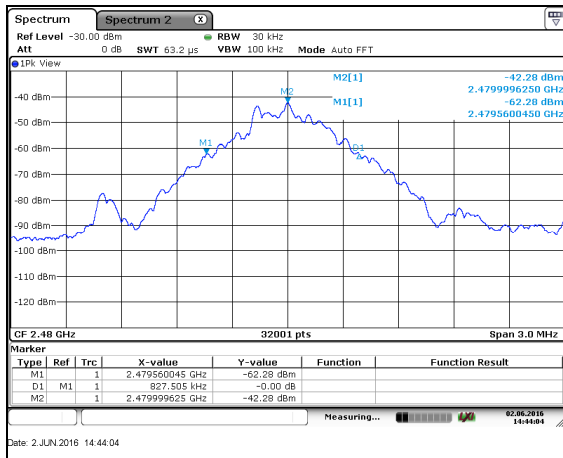

Figure 7.3.2-3: 20dB BW High CH (GFSK - 1Mbps)

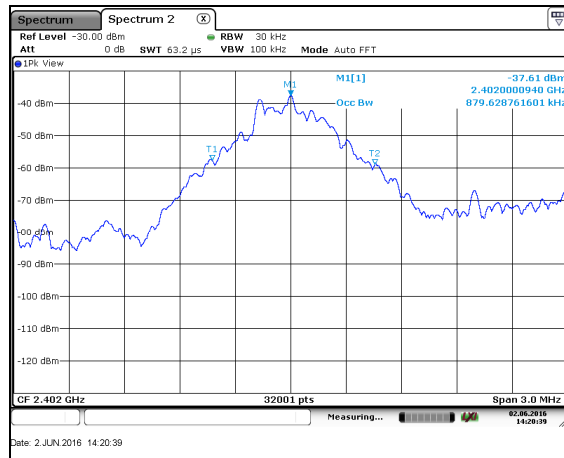

Figure 7.3.2-4: 99% OBW Low CH (GFSK - 1Mbps)

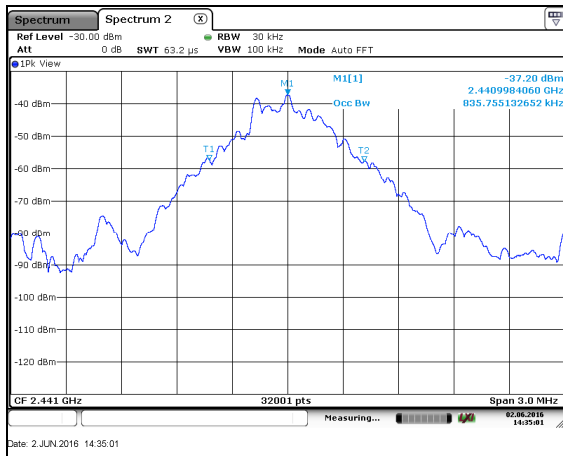

Figure 7.3.2-5: 99% OBW Mid CH (GFSK - 1Mbps)

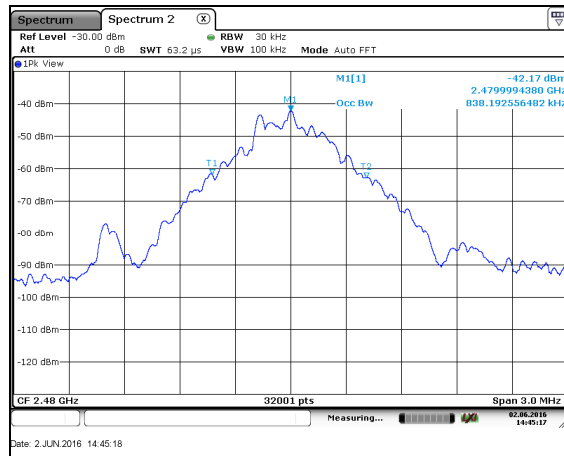

Figure 7.3.2-6: 99% OBW High CH (GFSK - 1Mbps)

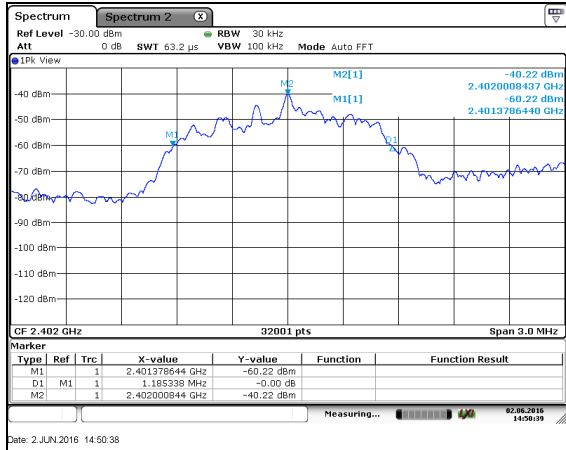

Figure 7.3.2-7: 20dB BW Low CH ($\pi/4$ DQPSK - 2Mbps)

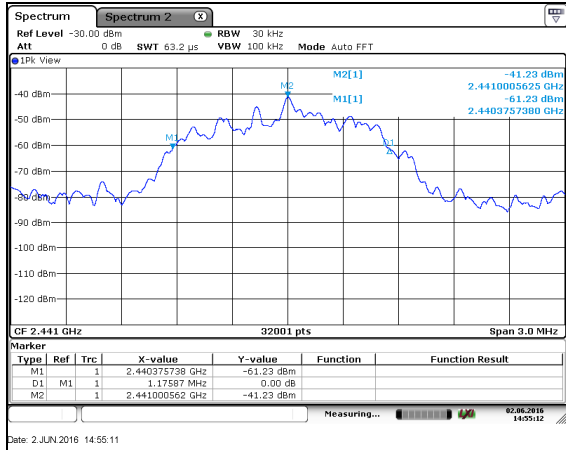

Figure 7.3.2-8: 20dB BW Mid CH ($\pi/4$ DQPSK - 2Mbps)

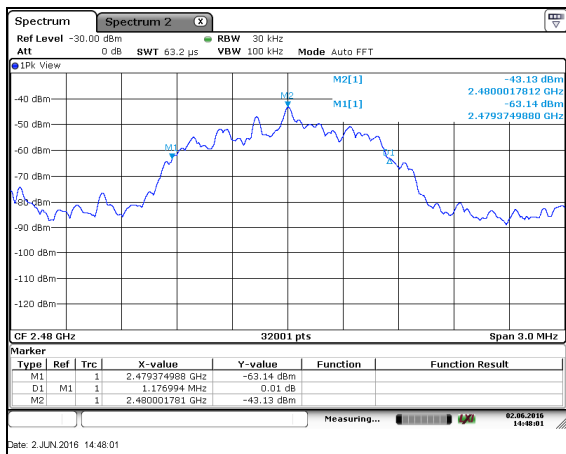

Figure 7.3.2-9: 20dB BW High CH ($\pi/4$ DQPSK - 2Mbps)

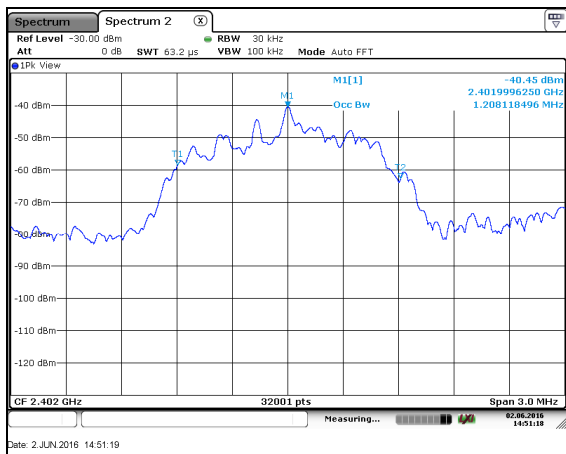

Figure 7.3.2-10: 99% OBW Low CH ($\pi/4$ DQPSK - 2Mbps)

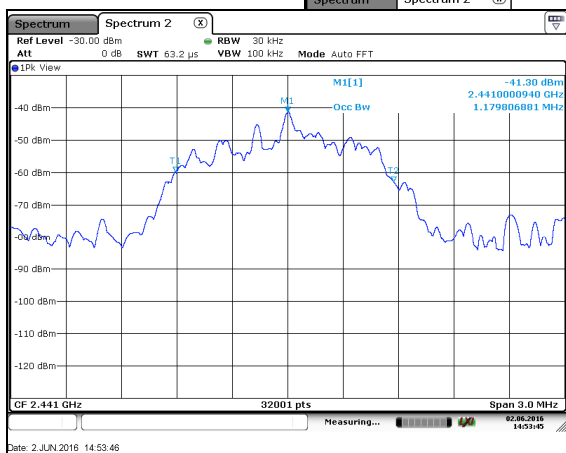

Figure 7.3.2-11: 99% OBW Mid CH ($\pi/4$ DQPSK - 2Mbps)

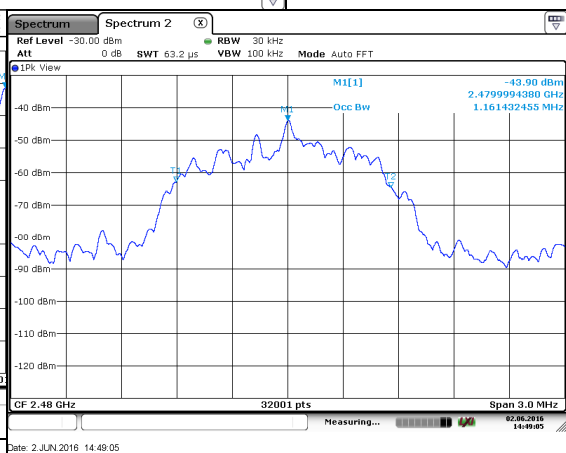

Figure 7.3.2-12: 99% OBW High CH ($\pi/4$ DQPSK - 2Mbps)

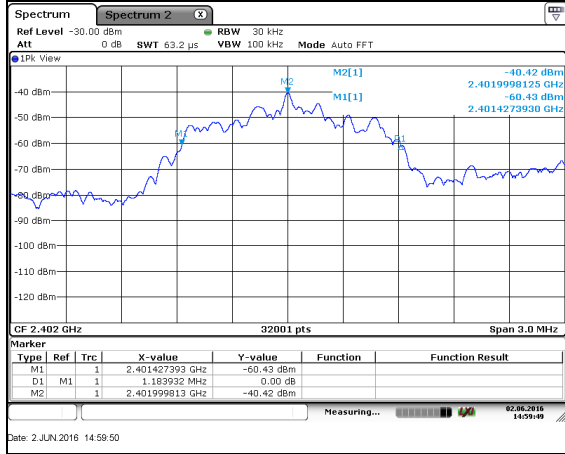

Figure 7.3.2-13: 20dB BW Low CH (8DPSK - 3Mbps)

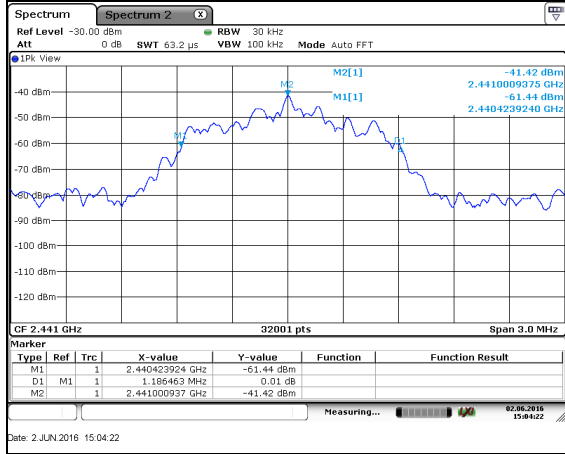

Figure 7.3.2-14: 20dB BW Mid CH (8DPSK - 3Mbps)

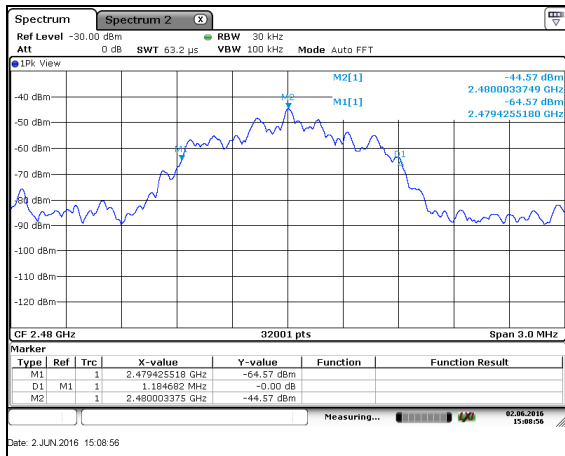

Figure 7.3.2-15: 20dB BW High CH (8DPSK - 3Mbps)

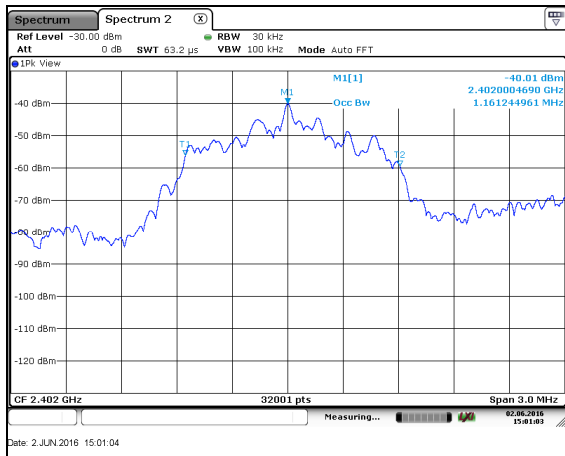

Figure 7.3.2-16: 99% OBW Low CH (8DPSK - 3Mbps)

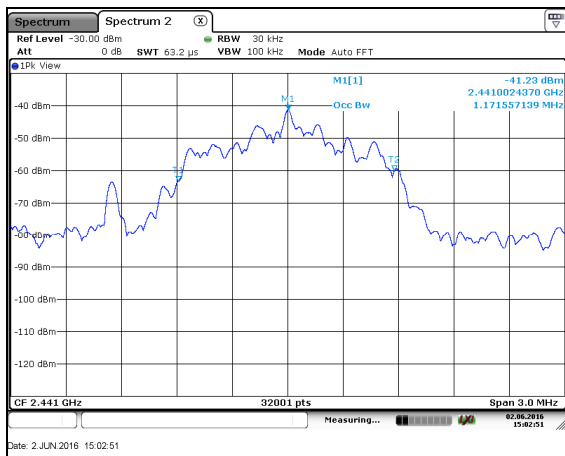

Figure 7.3.2-17: 99% OBW Mid CH (8DPSK - 3Mbps)

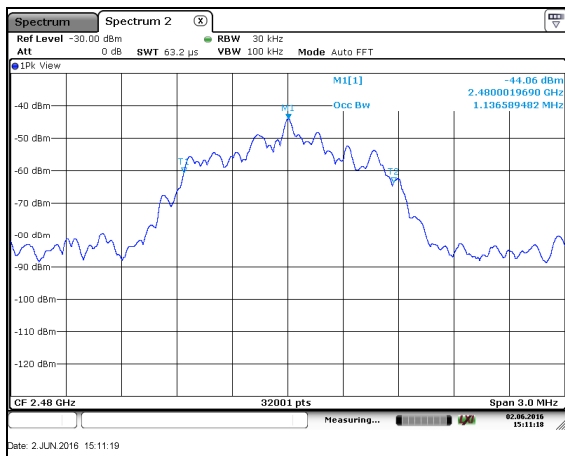

Figure 7.3.2-18: 99% OBW High CH (8DPSK - 3Mbps)

7.4 Fundamental Field Strength – FCC 15.249(a); IC RSS-210 A2.9(a)

7.4.1 Measurement Procedure

The EUT was rotated through 360° and the receive antenna height was varied from 1m to 4m so that the maximum radiated emissions level would be detected. Peak and average measurements were made with RBW and VBW of 3 MHz and 10 MHz respectively.

7.4.2 Duty Cycle Correction

For average radiated measurements, using a 6.25% duty cycle, the measured level was reduced by a factor 24.08dB. The duty cycle correction factor is determined using the formula: $20\log(6.25/100)$.

A detail explanation of the duty cycle is provided in the theory of operation accompanying this report.

7.4.3 Measurement Results

Results are shown below in Tables 7.4.2-1 to 7.4.2-3.

Table 7.4.3-1: Fundamental Field Strength (GFSK - 1Mbps)

Frequency (MHz)	Level (dBuV)		Antenna Polarity (H/V)	Correction Factors (dB)	Corrected Level (dBuV/m)		Limit (dBuV/m)		Margin (dB)	
	pk	Qpk/Avg			pk	Qpk/Avg	pk	Qpk/Avg	pk	Qpk/Avg
2402	78.29	73.60	H	-5.32	72.97	44.19	114.0	94.0	41.0	49.8
2402	76.27	71.60	V	-5.32	70.95	42.19	114.0	94.0	43.1	51.8
2441	79.31	71.13	H	-5.13	74.18	41.91	114.0	94.0	39.8	52.1
2441	75.43	67.30	V	-5.13	70.30	38.08	114.0	94.0	43.7	55.9
2480	78.40	73.55	H	-4.94	73.46	44.52	114.0	94.0	40.5	49.5
2480	74.31	69.67	V	-4.94	69.37	40.64	114.0	94.0	44.6	53.3

Table 7.4.3-2: Fundamental Field Strength ($\pi/4$ DQPSK - 2Mbps)

Frequency (MHz)	Level (dBuV)		Antenna Polarity (H/V)	Correction Factors (dB)	Corrected Level (dBuV/m)		Limit (dBuV/m)		Margin (dB)	
	pk	Qpk/Avg			pk	Qpk/Avg	pk	Qpk/Avg	pk	Qpk/Avg
2402	79.69	71.59	H	-5.32	74.37	42.18	114.0	94.0	39.6	51.8
2402	75.63	67.76	V	-5.32	70.31	38.35	114.0	94.0	43.7	55.6
2441	80.03	71.93	H	-5.13	74.90	42.71	114.0	94.0	39.1	51.3
2441	75.30	67.18	V	-5.13	70.17	37.96	114.0	94.0	43.8	56.0
2480	77.48	69.51	H	-4.94	72.54	40.48	114.0	94.0	41.5	53.5
2480	72.61	64.71	V	-4.94	67.67	35.68	114.0	94.0	46.3	58.3

Table 7.4.3-3: Fundamental Field Strength (8DPSK - 3Mbps)

Frequency (MHz)	Level (dBuV)		Antenna Polarity (H/V)	Correction Factors (dB)	Corrected Level (dBuV/m)		Limit (dBuV/m)		Margin (dB)	
	pk	Qpk/Avg			pk	Qpk/Avg	pk	Qpk/Avg	pk	Qpk/Avg
2402	79.75	70.48	H	-5.32	74.43	41.07	114.0	94.0	39.6	52.9
2402	77.02	67.89	V	-5.32	71.70	38.48	114.0	94.0	42.3	55.5
2441	79.46	70.27	H	-5.13	74.33	41.05	114.0	94.0	39.7	52.9
2441	76.24	67.13	V	-5.13	71.11	37.91	114.0	94.0	42.9	56.1
2480	77.58	68.47	H	-4.94	72.64	39.44	114.0	94.0	41.4	54.5
2480	71.29	62.27	V	-4.94	66.35	33.24	114.0	94.0	47.7	60.7

7.5 Radiated Spurious Emissions – FCC 15.249(a)(d)(e); IC RSS-210 A2.9(a)(b)

7.5.1 Measurement Procedure

Radiated emissions tests were made over the frequency range of 30MHz to 25 GHz, 10 times the highest fundamental frequency.

The EUT was rotated through 360° and the receive antenna height was varied from 1m to 4m so that the maximum radiated emissions level would be detected. For frequencies below 1000MHz, quasi-peak measurements were made using a resolution bandwidth RBW of 120 kHz and a video bandwidth VBW of 300 kHz. For frequencies above 1000MHz, peak and average measurements were made with RBW and VBW of 1 MHz and 3MHz respectively. The average emissions were further corrected by applying the duty cycle correction of the EUT for comparison to the average limit.

Radiated emissions were evaluated for all modulations and data rates.

All out of band emissions were evaluated, including any emissions at or near the band-edge.

7.5.2 Duty Cycle Correction

For average radiated measurements, using a 6.25% duty cycle, the measured level was reduced by a factor 24.08dB. The duty cycle correction factor is determined using the formula: $20\log(6.25/100)$.

A detail explanation of the duty cycle is provided in the theory of operation accompanying this report.

7.5.3 Measurement Results

Radiated spurious emissions are reported in the table 7.5.3-1 to 7.5.3-3 below.

Table 7.5.3-1: Radiated Spurious Emissions Tabulated Data (GFSK - 1Mbps)

Frequency (MHz)	Level (dBuV)		Antenna Polarity (H/V)	Correction Factors (dB)	Corrected Level (dBuV/m)		Limit (dBuV/m)		Margin (dB)	
	pk	Qpk/Avg			pk	Qpk/Avg	pk	Qpk/Avg	pk	Qpk/Avg
2402 MHz (Low Channel)										
2400	48.89	37.72	H	-5.33	43.56	8.30	74.0	54.0	30.4	45.7
2400	48.67	36.83	V	-5.33	43.34	7.41	74.0	54.0	30.7	46.6
4804	59.46	52.88	H	2.02	61.48	30.82	74.0	54.0	12.5	23.2
4804	67.73	61.54	V	2.02	69.75	39.48	74.0	54.0	4.3	14.5
2441 MHz (Middle Channel)										
4882	53.36	41.33	H	2.26	55.62	19.51	74.0	54.0	18.4	34.5
4882	59.48	47.12	V	2.26	61.74	25.30	74.0	54.0	12.3	28.7
2480 MHz (High Channel)										
4960	57.05	44.96	H	2.51	59.56	23.38	74.0	54.0	14.4	30.6
4960	59.15	47.19	V	2.51	61.66	25.61	74.0	54.0	12.3	28.4

Table 7.5.3-2: Radiated Spurious Emissions Tabulated Data ($\pi/4$ DQPSK - 2Mbps)

Frequency (MHz)	Level (dBuV)		Antenna Polarity (H/V)	Correction Factors (dB)	Corrected Level (dBuV/m)		Limit (dBuV/m)		Margin (dB)	
	pk	Qpk/Avg			pk	Qpk/Avg	pk	Qpk/Avg	pk	Qpk/Avg
2402 MHz (Low Channel)										
2400	52.35	36.45	H	-5.33	47.02	7.03	74.0	54.0	27.0	47.0
2400	50.20	35.28	V	-5.33	44.87	5.86	74.0	54.0	29.1	48.1
4804	55.83	45.25	H	2.02	57.85	23.19	74.0	54.0	16.2	30.8
4804	63.55	53.19	V	2.02	65.57	31.13	74.0	54.0	8.4	22.9
2441 MHz (Middle Channel)										
4882	53.16	40.77	H	2.26	55.42	18.95	74.0	54.0	18.6	35.0
4882	61.03	48.39	V	2.26	63.29	26.57	74.0	54.0	10.7	27.4
2480 MHz (High Channel)										
4960	59.12	44.68	V	2.51	61.63	23.10	74.0	54.0	12.4	30.9

Table 7.5.3-3: Radiated Spurious Emissions Tabulated Data (8DPSK - 3Mbps)

Frequency (MHz)	Level (dBuV)		Antenna Polarity (H/V)	Correction Factors (dB)	Corrected Level (dBuV/m)		Limit (dBuV/m)		Margin (dB)	
	pk	Qpk/Avg			pk	Qpk/Avg	pk	Qpk/Avg	pk	Qpk/Avg
2402 MHz (Low Channel)										
2400	52.32	36.27	H	-5.33	46.99	6.85	74.0	54.0	27.0	47.1
2400	50.21	35.31	V	-5.33	44.88	5.89	74.0	54.0	29.1	48.1
4804	55.09	44.25	H	2.02	57.11	22.19	74.0	54.0	16.9	31.8
4804	63.05	51.71	V	2.02	65.07	29.65	74.0	54.0	8.9	24.4
2441 MHz (Middle Channel)										
4882	59.86	46.71	H	2.26	62.12	24.89	74.0	54.0	11.9	29.1
4882	57.93	44.86	V	2.26	60.19	23.04	74.0	54.0	13.8	31.0
2480 MHz (High Channel)										
4960	58.21	43.36	H	2.51	60.72	21.78	74.0	54.0	13.3	32.2
4960	55.22	41.17	V	2.51	57.73	19.59	74.0	54.0	16.3	34.4

7.5.4 Sample Calculation:

$$R_C = R_U + CF_T$$

Where:

 $CF_T =$ Total Correction Factor (AF+CA+AG)-DC (Average Measurements Only) $R_U =$ Uncorrected Reading $R_C =$ Corrected Level $AF =$ Antenna Factor $CA =$ Cable Attenuation $AG =$ Amplifier Gain $DC =$ Duty Cycle Correction Factor**Example Calculation: Peak**Corrected Level: $48.89 - 5.33 = 43.56\text{dBuV/m}$ Margin: $74.0\text{dBuV/m} - 43.56\text{dBuV/m} = 30.4\text{dB}$ **Example Calculation: Average**Corrected Level: $37.72 - 5.33 - 24.08 = 8.30\text{dBuV}$ Margin: $54.0\text{dBuV} - 8.30\text{dBuV} = 45.7\text{dB}$

8 CONCLUSION

In the opinion of ACS, Inc. the MRX920v3, provided by Neptune Technology Group Inc., meets the requirements of FCC Part 15 subpart C and Industry Canada's Radio Standards Specification RSS-210.

END REPORT