

GHOSC 4K

Quick Guide

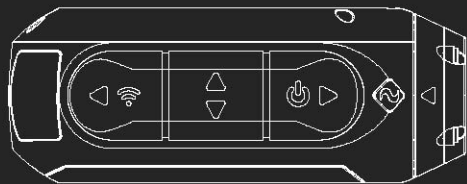
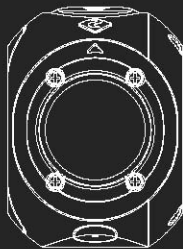

Thank you for purchasing the Drift Ghost 4K

CUSTOMER SUPPORT

Download the full manual and check our official website for firmware updates, customer support, and info on all of our products.

<https://driftinnovation.com/>

If you have any suggestions, comments or concerns; please contact our customer support team at:

support@driftinnovation.com



WARRANTY

Warranty does not apply if the product is damaged due to physical abuse, mishandling, accident, fire, frostbite, water damage, negligence or failure to follow the supplied operating instructions. For more information on your warranty, see:

<https://driftinnovation.com/warranty>

- 3-4 About Your Camera | Package Contents
- 5-6 Initial Setup | Getting Started
 - 7 Camera Modes
 - 8 Settings Menu
- 9-10 Settings
 - 11 Mounting the Camera
- 12-13 Feature Overview
 - 14 Accessory Guide
 - 15 Wi-Fi + Firmware
 - 16 Connecting Your Camera
- 17-18 Specifications
- 19-21 Disclosures

About Your Camera

- A**  Rear Button
- B**  Middle Button
- C**  Front Button
- D** Status LED
- E** Rotating Lens
- F** Battery Module
- G** Module Latch
- H** Wi-Fi LED
- I** Rear Screen
- J** Dual microphones
- K** Reset Button
- L** MicroSD Card Slot
- M** 10 Pin Mini USB Port
- N** Rubber Cover

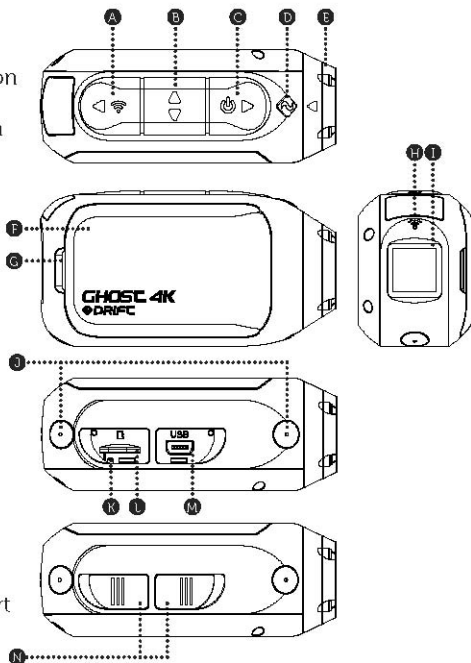

Package Contents

- A Ghost 4K Camera
- B Universal Clip
- C Flat Adhesive Mount
- D Curved Adhesive Mount
- E USB-Mic Converter
- F MiniUSB Cable

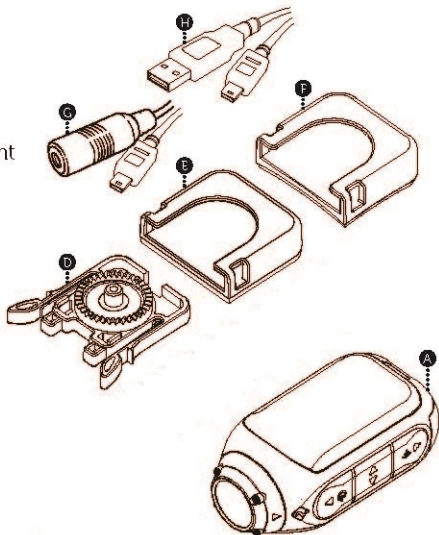

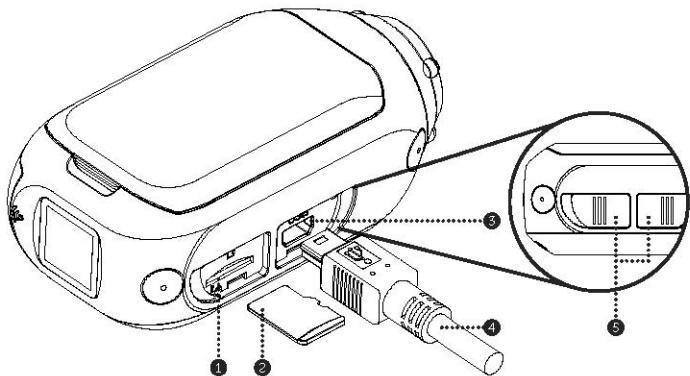

Initial Setup

1. Uncover the microSD slot by lifting its rubber cover.
2. Insert a Class 10 or higher microSD/HC/XC card (up to 64GB).
Format before first usage!
3. Uncover the mini USB port by lifting its rubber cover.
4. Connect the camera via a mini USB cable to a powered USB port, and charge the battery for 2.5 hours before first use.
5. Replace the rubber covers securely to cover both the microSD slot and mini USB port. You are ready to go!



POWER ON/OFF

1. Press and hold the  button to power on.
2. The Rear Screen will power on, showing the welcome display.
3. The camera is now ready to record video or take photos.
4. Current camera mode is indicated by the colour of the Status LED and Rear Screen, along with the icon in the top left of the Rear Screen.
5. To power off, press and hold the  button for 3 seconds.

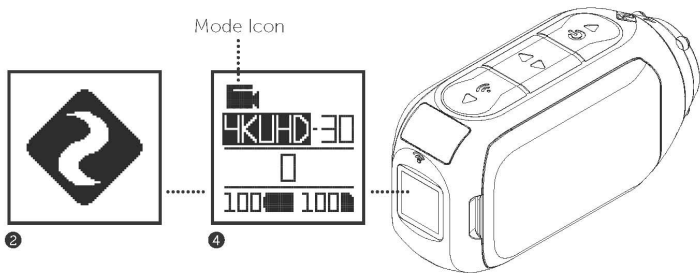

MODE NAVIGATION

To change the current camera recording mode, press the  button; changing between Video, Photo, Timelapse, Photoburst, Favourites* and General Settings modes. *Favourites available if option is turned on.

VIDEO MODE

(Green LED) Press the  button to start recording. The Status LED and LCD backlight will flash red to indicate recording. Press the  button again to stop recording.

VIDEO SETTINGS

- Resolution
- Frame Rate

PHOTO MODE



(Yellow LED) The camera will capture still images when the  button is pressed, and the status LED and LCD screen will flash red each time a photo is captured.

PHOTO SETTINGS

- Resolution

TIMELAPSE MODE

(Purple LED) Press the  button to capture a series of still images at a specified rate. The Status LED and LCD screen will flash red each time an image is captured. To stop recording, press the  button once more.

TIMELAPSE SETTINGS

- Resolution
- Timelapse Interval



PHOTOBURST MODE

(Cyan LED) The camera will capture a burst of still images for an allotted duration and at a specified rate, when the  button is pressed. For best results, use a memory card with the highest possible data rate.

PHOTOBURST SETTINGS

- Resolution
- Burst Duration
- Capture Rate

SETTINGS MENU NAVIGATION

1. On arrival to the settings menu, the highlight black box rests on the top, highlighting the Settings Menu icon as the starting position.
2. Press the  button to navigate down, this highlights the next setting.
3. Press the  button to change the option for that setting.
4. At any time, press the  button to change mode (returning to Video).

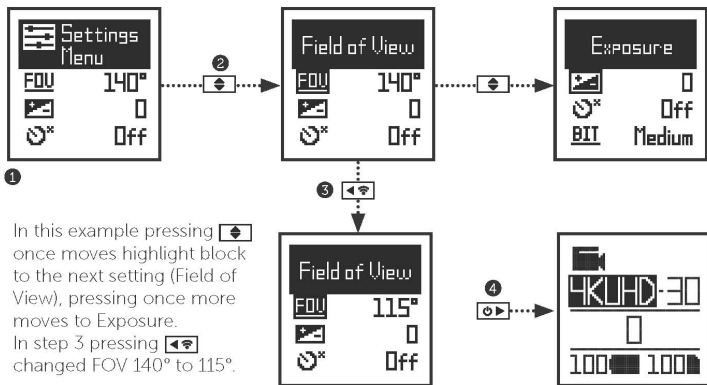

In this example pressing  once moves highlight block to the next setting (Field of View), pressing once more moves to Exposure.

In step 3 pressing  changed FOV 140° to 115°.

Field of View	90° / 115° / 140°
Exposure	-2 / -1 / 0 / +1 / +2
Self Timer	OFF / 3S / 5S / 10S
Video Bit Rate	HIGH / MEDIUM / LOW
Video Filter	NORMAL / VIVID / LOW LIGHT / WATER
ISO	100 / 200 / 400 / 800 / AUTO
Video Tagging	YES / NO
Video Tagging Interval	10S / 30S / 1MIN / 2MIN / 5MIN / 10MIN
Car DVR	YES / MANUAL / NO
Car DVR Loop Interval	1MIN / 2MIN / 5MIN / 10MIN
Simultaneous Photo	OFF / ON
Simultaneous Photo Interval	2S / 5S / 10S / 30S / 1MIN / 2MIN / 5MIN / 10MIN
Video Stabilization	OFF / ON
Microphone	FRONT ONLY / BACK ONLY
Front Mic Sensitivity	OFF / LOW / MED / HIGH
Rear Mic Sensitivity	OFF / LOW / MED / HIGH
Speaker Volume	OFF / LOW / MED / HIGH

Settings

Status Indicator LED	OFF / ON
Wi-Fi	OFF / ON / ALWAYS ON
Remote Control Pairing	YES / NO
Instant Record	YES / NO
Video Standard	ALL / NTSC / PAL / CINEMATIC
Date	YYYY/MM/DD HH/mm
Date Stamp	OFF / ON
Default Start-Up Mode	RESUME LAST SESSION / VIDEO / PHOTO / TIMELAPSE / PHOTOBURST / VIDEO + PHOTO
Camera Off	NO / 2MIN / 5MIN / 10MIN / 20MIN
THM Files	ON / OFF
Language	EN / FR / DE / ES / IT / CN
Reset Settings	YES / NO
Format SD Card	YES / NO
Serial Number	XXXXXX
Firmware Version	XXXXXX

Mounting the Camera

1. Attach the Universal Clip to the camera in any 360° orientation as needed – first position the clip in the desired orientation, then secure by rotating the screw base by hand.
2. Slide the Universal Clip into your chosen mount, ensuring that it 'clicks' into place. ****Double check it has been fully inserted by pushing out the clips.***
3. Align your shot. Rotate the lens by hand, using the lens marker as an 'up' reference, maintaining it perpendicular to the ground for correct orientation.

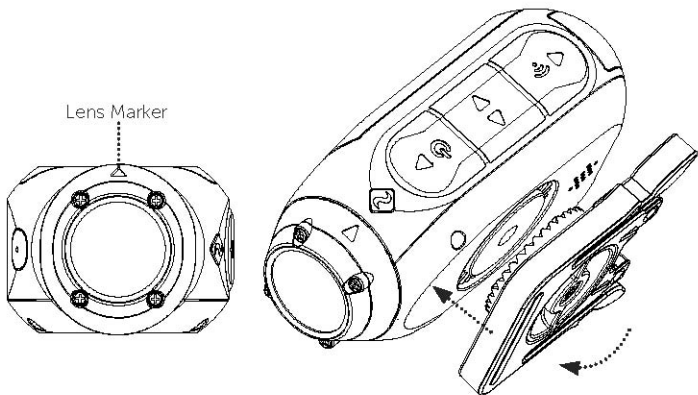

CAR DVR MODE

This hands-off mode is ideal for insurance and security purposes.

The camera records footage in a continuous loop style (DVR Intervals) recording loop after loop until it fills the MicroSD Card. Once full, the oldest loops will be deleted as the newer ones are saved. The DVR loop interval can be 10s, 30s, 1min, 2min, 5min or 10min.

VIDEO TAGGING

When activated, this feature allows the camera to continuously record video, but only save when important footage is "Tagged".

While recording video, pressing the  button will save past, present and future video. For example, with a video tagging interval of 30s selected, the camera will save the previous 30s, the current 30s, and an additional 30s – a total of 1m 30s "tagged" footage. ***The Video Tagging feature requires a class 10 micro SD card with 4GB of free space to function correctly.***

INSTANT ON MODE

Enabling Instant On Mode allows the camera to turn on, and immediately start recording with a single press of the  button.

CINEMATIC MODE

Selecting Cinematic Mode will allow the user to film in frame rates of 24 or 48fps. Navigate to the 'Video Standard' option in settings menu to enable Cinematic Mode.

DUAL FRONT AND REAR MICROPHONES

The Ghost 4K features two microphones - located in the front and the rear of the camera, to help ensure the best possible sound at all times. We recommend selection of the front microphone while the camera is stationary; the rear microphone being ideal for reducing wind noise while the camera is moving.

BIT RATE

Users can choose to keep the normal compression used by the H.264 codec, or if they prefer, allow a higher flow of data for preserving more of the original recording. This will result in a bigger file size.

FILTER

Quickly tailor your cameras settings to the recording conditions with filters. Choose between Normal / Vivid / Low Light / Water.

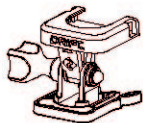

PIVOT MOUNT

Mountable anywhere at nearly any angle, the Drift Pivot Mount is your tool to capture the moment from any point of view you can imagine. Includes flat and curved adhesives, and can be used together with any other Drift mount.

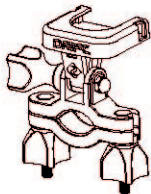

HANDLEBAR MOUNT

The Drift handlebar mount is the perfect accessory for riders, whatever your discipline. Compatible with bars between 19mm and 36mm, and capable of pivoting more than 180 degrees, the handlebar mount opens up almost any angle for your video.

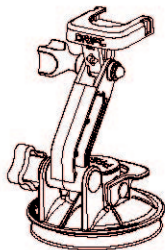

SUCTION CUP MOUNT

The ideal accessory for mounting your Ghost 4K to any non-porous flat surface. Ideal for use on car windshields or bodywork, the Suction Cup makes it simple to turn, tilt, and rotate your camera 360°.

To turn on your Ghost 4K Wi-Fi, simply press and hold the  button. A blue Wi-Fi indicator LED shows that Wi-Fi is enabled.

Wi-Fi can also be turned on via the camera's settings menu, where you'll also find an option to permanently switch the Wi-Fi network on.

DOWNLOAD THE DRIFT LIFE APP

Setup your shot, capture, playback, edit and live stream on your mobile device.



INSTALLING FIRMWARE

Download the latest firmware from the Drift website and copy the Ghost_4K.bin file into the root of a formatted micro SD card. Insert the micro SD card into the camera and power on.

The camera screen will display 'Firmware Updating' as the update is installed. Once complete, the camera will power down.

Connecting Your Camera

CONNECTING TO A PC

1. Connect the camera using the USB cable (provided); the camera screen will show a USB icon.
2. The camera's folder may open automatically; if not, open using My Computer.
3. The camera should be recognised as a removable disk; double-click to open.
4. Open the DCIM folder to access your files.

CONNECTING TO A MAC

1. Connect the camera using the USB cable (provided); the camera screen will show a USB icon.
2. The camera's folder may open automatically; if not, open using Finder.
3. The camera should be recognised as an external device; double-click to open.
4. Open the DCIM folder to access your files.

Specifications

Video Resolution and Frame Rates:

4K (4096 X 2160 17:1)	25 FPS
4K UHD (3840 X 2160, 16:9)	24 / 25 / 30 FPS
2.7K (2704 X 1520 16:9)	24 / 25 / 30 / 60 FPS
1080P (1920 X 1080 16:9)	24 / 25 / 30 / 50 / 60 / 100 / 120 FPS
720P (1280 X 720 16:9)	25 / 30 / 48 / 50 / 60 / 200 / 240 FPS

File format:	.MP4 (H.264 codec)
Sensor type:	CMOS
Field-of-view (diagonal):	90° / 115° / 140°
Lens focal range:	0.5m to infinity
Lens rotation:	300°
Zoom:	x10 (digital)
Photo mode:	5 / 8 / 12 mega-pixels
Exposure:	Auto / Step Manual (Advanced Users)
LCD Screen:	Color Dot Matrix Backlit LCD
Microphones:	Dual Front/Rear Microphones
Memory Capacity:	Micro SD, SDHC, SDXC memory cards up to 64GB

Inputs:	Mini USB 10 Pin, External Microphone via USB adaptor.
Outputs:	A/V and HDMI Out via USB Adapter.
Connectivity:	USB Plug And Play, Mini USB 10 Pin.
Power:	1500mAh internal, 500mAh modular battery included.
Radio Frequency:	2.4Ghz
Camera Dimensions:	43 (W) x 82.2 (L) x 31.4 (D) mm
Weight:	120g
Compatibility:	Windows XP and up / Mac OS 10.2 and up For 4K viewing a monitor capable of playback is required. For viewing / editing minimum requirements include: 8GB RAM integrated graphics, 4th generation i5 and 17 Intel® Core™ or AMD A10-7800 APU. Discreet graphics cards starting from GeForce® GTX™ 650, or AMD Radeon™ HD 7000 Series and above. Due to the immense processing required to render 4K, meeting system requirements may still lead to staggered or choppy playback.

FCC Information

This device complies with Part 15 of the FCC Rules.

Operation is subject to the following two conditions:

- (1) this device may not cause harmful interference, and
- (2) this device must accept interference received, including interference that may cause undesired operation.

WARNING

Changes or modifications to this unit not expressly approved by the party responsible for compliance could void the user's authority to operate the equipment.

The equipment has been tested and found to comply with the limits for a Class B digital device, pursuant

to Part 15 of the FCC Rules. These limits are designed to provide reasonable protection against harmful interference in a residential installation. This equipment generates, uses, and can radiate radio frequency energy and, if not installed and used in accordance with the instructions, may cause harmful interference to radio communications. However, there is no guarantee that interference will not occur in a particular installation. If this equipment does cause harmful interference to radio or television reception, which can be determined by powering the equipment on and off, the user is encouraged to try to correct the interference by one or more of the following measures:

Reorient or relocate the receiving antenna;

Increase the separation between the equipment and the receiver;

Connect the equipment into an outlet on a circuit different from that which the receiver is connected;

Consult the dealer or an experienced radio / TV technician for help.

This device complies with Industry Canada license-exempt RSS standard(s).

Operation is subject to the following two conditions:

- (1) this device may not cause interference, and
- (2) this device must accept any interference, including interference that may cause undesired operation of the device.

This Class [B] digital apparatus complies with Canadian ICES-003. Son fonctionnement est soumis aux deux conditions suivantes:

- (1) cet appareil ne peut pas causer l'intervention, et
- (2) cet appareil doit accepter de l'intervention, y compris l'intervention qui peut causer l'opération non désirée de.

Cet appareil numérique de la classe [B] est conforme à la norme NMB-003 du Canada.

Cet appareil s'accorde avec Industrie Canada licence-exempte RSS standard.

FCC STATEMENT :

This device complies with Part 15 of the FCC Rules. Operation is subject to the following two conditions:

(1) This device may not cause harmful interference, and (2) This device must accept any interference received, including interference that may cause undesired operation.

2.Warning: Changes or modifications not expressly approved by the party responsible for compliance could void the user's authority to operate the equipment.

NOTE: This equipment has been tested and found to comply with the limits for a Class B digital device, pursuant to Part 15 of the FCC Rules. These limits are designed to provide reasonable protection against harmful interference in a residential installation. This equipment generates uses and can radiate radio frequency energy and, if not installed and used in accordance with the instructions, may cause harmful interference to radio communications. However, there is no guarantee that interference will not occur in a particular installation. If this equipment does cause harmful interference to radio or television reception, which can be determined by turning the equipment off and on, the user is encouraged to try to correct the interference by one or more of the following measures:

Reorient or relocate the receiving antenna.

Increase the separation between the equipment and receiver.

Connect the equipment into an outlet on a circuit different from that to which the receiver is connected.

Consult the dealer or an experienced radio/TV technician for help.

RF warning statement:

The device has been evaluated to meet general RF exposure requirement. The device can be used in portable exposure condition without restriction.