



TEST REPORT

Report Reference No...... : **TRE1404018101** R/C.....: 69315
FCC ID..... : **P2F-FD9963**
IC ID..... : **10574A-FD9963**
Applicant's name..... : **Drift Innovation Ltd**
Address..... : The Light Box Unit 125, 111 Power Road ,London,UK.
Manufacturer..... : Foxda Technology Industrial(Shenzhen) Co.,Ltd
Address..... : 1F of 1st Building&1F-3F of 2nd Building, Foxda Industrial Zone,North of Lanzhu Road,Pingshan New District,Shenzhen City,Guangdong Province,P.R.China
Test item description : **STEALTH 2**
Trade Mark : Drift
Model/Type reference..... : FD9963
Listed Model(s) : /
Standard : **FCC CFR Title 47 Part 15 Subpart C Section 15.249**
RSS-210 Issue 8
Date of receipt of test sample.....: Apirl 29, 2014
Date of testing.....: Apirl 30, 2014- Jun 11, 2014
Date of issue.....: Jun 11, 2014
Result.....: **PASS**

Compiled by
 (position+printed name+signature)..: File administrators Vivi Zhou 
Supervised by
 (position+printed name+signature)..: Project Engineer Lion Cai 
Approved by
 (position+printed name+signature)..: RF Manager Hans Hu 

Testing Laboratory Name : **Shenzhen Huatongwei International Inspection Co., Ltd**
Address..... : Keji Nan No.12 Road, Hi-tech Park, Shenzhen, China

Shenzhen Huatongwei International Inspection Co., Ltd. All rights reserved.

This publication may be reproduced in whole or in part for non-commercial purposes as long as the Shenzhen Huatongwei International Inspection Co., Ltd is acknowledged as copyright owner and source of the material. Shenzhen Huatongwei International Inspection Co., Ltd takes no responsibility for and will not assume liability for damages resulting from the reader's interpretation of the reproduced material due to its placement and context.

1.	<u>TEST STANDARDS AND TEST DESCRIPTION.....</u>	3
1.1.	Test Standards	3
1.2.	Test Description	3
2.	<u>SUMMARY</u>	4
2.1.	Client Information	4
2.2.	Product Description	4
2.3.	EUT configuration	4
2.4.	Modifications	4
3.	<u>TEST ENVIRONMENT</u>	5
3.1.	Address of the test laboratory	5
3.2.	Test Facility	5
3.3.	Environmental conditions	6
3.4.	Statement of the measurement uncertainty	6
3.5.	Equipments Used during the Test	7
4.	<u>TEST CONDITIONS AND RESULTS.....</u>	8
4.1.	Antenna requirement	8
4.2.	AC Conducted Emissions Test	9
4.3.	Radiated Emission Test	12
4.4.	Out of band emissions	16
4.5.	20dB Bandwidth and 99% Occupancy Bandwidth Measurement	18
5.	<u>TEST SETUP PHOTOS OF THE EUT</u>	20
6.	<u>EXTERNAL AND INTERNAL PHOTOS OF THE EUT</u>	22

1. TEST STANDARDS AND TEST DESCRIPTION

1.1. Test Standards

The tests were performed according to following standards:

[47 CFR FCC Rules Part 15.249](#): Frequency Hopping, Direct Spread Spectrum and Hybrid Systems that are in operation within the bands of 902-928 MHz, 2400-2483.5 MHz, 5725-5850 MHz and 24.0 - 24.25 GHz.

[ANSI C63.10](#): American National Standard for Testing Unlicensed Wireless Devices

[RSS-210 Issue 8](#): –Licence-exempt Radio Apparatus (All Frequency Bands): Category I Equipment

[RSS-Gen Issue 3](#): –General Requirements and Information for the Certification of Radio Apparatus

1.2. Test Description

Test Item	Section in CFR 47	RSS-210 Annex 8	Result
Antenna requirement	15.203	RSS-210 Annex 8	Pass
AC Power Conducted Emission	15.207	RSS-Gen 7.12	Pass
Radiated Emission	15.109/ 15.205/ 15.209/15.249 (a)	RSS-Gen 7.2.5 RSS-Gen 7.2.4	Pass
Band Edge	15.249(d)	RSS-Gen 7.2.2 RSS-Gen A2.9 (a)	Pass
20dB Bandwidth / 99% occupy bandwidth	15. 215	RSS-210 A2.9 (b)	Pass

Remark: The measurement uncertainty is not included in the test result.

2. SUMMARY

2.1. Client Information

Applicant:	Drift Innovation Ltd
Address:	The Light Box Unit 125, 111 Power Road ,London,UK.
Manufacturer:	Foxda Technology Industrial(Shenzhen) Co.,Ltd
Address:	1F of 1st Building&1F-3F of 2nd Building, Foxda Industrial Zone,North of Lanzhu Road,Pingshan New District,Shenzhen City,Guangdong Province,P.R.China

2.2. Product Description

Name of EUT	STEALTH 2
Trade Mark:	Drift
Model/Type reference:	FD9963
Listed Model(s):	/
Power supply:	DC 3.7V From internal battery
Adapter information:	/
2.4GHz Transmitter	
Modulation:	GFSK
Operation frequency:	2430MHz
Channel number:	1
Antenna type:	Internal Antenna
Antenna gain:	0.08 dBi

2.3. EUT configuration

The following peripheral devices and interface cables were connected during the measurement:

- - supplied by the manufacturer
- - supplied by the lab

<input type="radio"/>	Power Cable	Length (m) :	/
		Shield :	/
		Detachable :	/
<input type="radio"/>	Multimeter	Manufacturer :	/
		Model No. :	/

2.4. Modifications

No modifications were implemented to meet testing criteria.

3. TEST ENVIRONMENT

3.1. Address of the test laboratory

Shenzhen Huatongwei International Inspection Co., Ltd.
Keji Nan No.12 Road, Hi-tech Park, Shenzhen, China
Phone: 86-755-26748019 Fax: 86-755-26748089

3.2. Test Facility

The test facility is recognized, certified, or accredited by the following organizations:

CNAS-Lab Code: L1225

Shenzhen Huatongwei International Inspection Co., Ltd. has been assessed and proved to be in compliance with CNAS-CL01 Accreditation Criteria for Testing and Calibration Laboratories (identical to ISO/IEC 17025: 2005 General Requirements) for the Competence of Testing and Calibration Laboratories, Date of Registration: Mar. 01, 2012. Valid time is until February 28, 2015.

A2LA-Lab Cert. No. 2243.01

Shenzhen Huatongwei International Inspection Co., Ltd. EMC Laboratory has been accredited by A2LA for technical competence in the field of electrical testing, and proved to be in compliance with ISO/IEC 17025: 2005 General Requirements for the Competence of Testing and Calibration Laboratories and any additional program requirements in the identified field of testing. Valid time is until Sept 30, 2015.

FCC-Registration No.: 662850

Shenzhen Huatongwei International Inspection Co., Ltd. EMC Laboratory has been registered and fully described in a report filed with the FCC (Federal Communications Commission). The acceptance letter from the FCC is maintained in our files. Registration 662850, Renewal date Jul. 01, 2012, valid time is until Jun. 01, 2015.

IC-Registration No.: 5377A

The 3m Alternate Test Site of Shenzhen Huatongwei International Inspection Co., Ltd. has been registered by Certification and Engineering Bureau of Industry Canada for the performance of radiated measurements with Registration No. 5377A on Dec. 31, 2013, valid time is until Dec. 31, 2016.

ACA

Shenzhen Huatongwei International Inspection Co., Ltd. EMC Laboratory can also perform testing for the Australian C-Tick mark as a result of our A2LA accreditation.

VCCI

The 3m Semi-anechoic chamber (12.2m×7.95m×6.7m) of Shenzhen Huatongwei International Inspection Co., Ltd. has been registered in accordance with the Regulations for Voluntary Control Measures with Registration No.:R-2484. Date of Registration: Dec. 20, 2012. Valid time is until Dec. 29, 2015.

Radiated disturbance above 1GHz measurement of Shenzhen Huatongwei International Inspection Co., Ltd. has been registered in accordance with the Regulations for Voluntary Control Measures with Registration No.: G-292. Date of Registration: Dec. 24, 2013. Valid time is until Dec. 23, 2016.

Main Ports Conducted Interference Measurement of Shenzhen Huatongwei International Inspection Co., Ltd. has been registered in accordance with the Regulations for Voluntary Control Measures with Registration No.: C-2726. Date of Registration: Dec. 20, 2012. Valid time is until Dec. 19, 2015.

Telecommunication Ports Conducted Interference Measurement of Shenzhen Huatongwei International Inspection Co., Ltd. has been registered in accordance with the Regulations for Voluntary Control Measures with Registration No.: T-1837. Date of Registration: May 07, 2013. Valid time is until May 06, 2016.

DNV

Shenzhen Huatongwei International Inspection Co., Ltd. has been found to comply with the requirements of DNV towards subcontractor of EMC and safety testing services in conjunction with the EMC and Low voltage Directives and in the voluntary field. The acceptance is based on a formal quality Audit and follow-ups according to relevant parts of ISO/IEC Guide 17025 (2005), in accordance with the requirements of the DNV Laboratory Quality Manual towards subcontractors. Valid time is until Aug. 24, 2016.

3.3. Environmental conditions

During the measurement the environmental conditions were within the listed ranges:

Temperature:	15~35°C
Relative Humidity:	30~60 %
Air Pressure:	950~1050mba

3.4. Statement of the measurement uncertainty

The data and results referenced in this document are true and accurate. The reader is cautioned that there may be errors within the calibration limits of the equipment and facilities. The measurement uncertainty was calculated for all measurements listed in this test report according to TR-100028-01 "Electromagnetic compatibility and Radio spectrum Matters (ERM); Uncertainties in the measurement of mobile radio equipment characteristics; Part 1" and TR-100028-02 "Electromagnetic compatibility and Radio spectrum Matters (ERM); Uncertainties in the measurement of mobile radio equipment characteristics; Part 2" and is documented in the Shenzhen Huatongwei International Inspection Co., Ltd quality system according to DIN EN ISO/IEC 17025. Furthermore, component and process variability of devices similar to that tested may result in additional deviation. The manufacturer has the sole responsibility of continued compliance of the device.

Hereafter the best measurement capability for Shenzhen Huatongwei laboratory is reported:

Test Items	Measurement Uncertainty	Notes
Transmitter power conducted	0.57 dB	(1)
Transmitter power Radiated	2.20 dB	(1)
Conducted spurious emission 9KHz-40 GHz	1.60 dB	(1)
Radiated spurious emission 9KHz-40 GHz	2.20 dB	(1)
Conducted Emission 9KHz-30MHz	3.39 dB	(1)
Radiated Emission 30~1000MHz	4.24 dB	(1)
Radiated Emission 1~18GHz	5.16 dB	(1)
Radiated Emission 18-40GHz	5.54 dB	(1)
Occupied Bandwidth	-----	(1)

(1) This uncertainty represents an expanded uncertainty expressed at approximately the 95% confidence level using a coverage factor of $k=1.96$.

3.5. Equipments Used during the Test

AC Power Conducted Emission					
Item	Test Equipment	Manufacturer	Model No.	Serial No.	Cal Due
1	Artificial Mains	Rohde&Schwarz	ESH2-Z5	100028	2014/10/25
2	EMI Test Receiver	Rohde&Schwarz	ESCI3	100038	2014/10/25
3	Pulse Limiter	Rohde&Schwarz	ESHSZ2	100044	2014/10/25
4	EMI Test Software	Rohde&Schwarz	ES-K1 V1.71	N/A	N/A

Radiated Emission					
Item	Test Equipment	Manufacturer	Model No.	Serial No.	Cal Due
1	Ultra-Broadband Antenna	ShwarzBeck	VULB9163	538	2014/10/25
2	EMI TEST RECEIVER	Rohde&Schwarz	ESI 26	100009	2014/10/25
3	EMI TEST Software	Audix	E3	N/A	N/A
4	TURNTABLE	ETS	2088	2149	N/A
5	ANTENNA MAST	ETS	2075	2346	N/A
6	EMI TEST Software	Rohde&Schwarz	ESK1	N/A	N/A
7	HORN ANTENNA	ShwarzBeck	9120D	1011	2014/10/25
8	Amplifer	Sonoma	310N	E009-13	2014/10/25
9	JS amplifer	Rohde&Schwarz	JS4-00101800-28-5A	F201504	2014/10/25
10	High pass filter	Compliance Direction systems	BSU-6	34202	2014/10/25
11	HORN ANTENNA	ShwarzBeck	9120D	1012	2014/10/25
12	Amplifer	Compliance Direction systems	PAP1-4060	120	2014/10/25
13	Loop Antenna	Rohde&Schwarz	HFH2-Z2	100020	2014/10/25
14	TURNTABLE	MATURO	TT2.0	----	N/A
15	ANTENNA MAST	MATURO	TAM-4.0-P	----	N/A
16	Horn Antenna	SCHWARZBECK	BBHA9170	25841	2014/10/25
17	ULTRA-BROADBAND ANTENNA	Rohde&Schwarz	HL562	100015	2014/10/25

Maximum Peak Output Power / Power Spectral Density / 6dB Bandwidth / Band Edge Compliance of RF Emission / Spurious RF Conducted Emission					
Item	Test Equipment	Manufacturer	Model No.	Serial No.	Cal Due
1	Spectrum Analyzer	Rohde&Schwarz	FSP	1164.4391.40	2014/10/25

The Cal.Interval was one year

4. TEST CONDITIONS AND RESULTS

4.1. Antenna requirement

Requirement

FCC CFR Title 47 Part 15 Subpart C Section 15.203:

An intentional radiator shall be designed to ensure that no antenna other than that furnished by the responsible party shall be used with the device. The use of a permanently attached antenna or of an antenna that uses a unique coupling to the intentional radiator, the manufacturer may design the unit so that a broken antenna can be replaced by the user, but the use of a standard antenna jack or electrical connector is prohibited.

RSS-Gen 7.1.2:

A transmitter can only be sold or operated with antennas with which it was approved. Transmitter may be approved with multiple antenna types. An antenna type comprises antennas having similar in-band and out-of-band radiation patterns. Testing shall be performed using the highest gain antenna of each combination of transmitter and antenna type for which approval is being sought, with the transmitter output power set at the maximum level. Any antenna of the same type having equal or lesser gain as an antenna that had been successfully tested with the transmitter, will also be considered approved with the transmitter, and may be used and marketed with the transmitter. For Category I transmitters, the manufacturer shall include with the application for certification a list of acceptable antenna types to be used with the transmitter.

When a measurement at the antenna connector is used to determine RF output power, the effective gain of the device's antenna shall be stated, based on measurement or on data from the antenna manufacturer. For transmitters of RF output power of 10 milliwatts or less, only the portion of the antenna gain that is in excess of 6 dBi (6 dB above isotropic gain) shall be added to the measured RF output power to demonstrate compliance with the radiated power limits specified in the applicable standard. For transmitters of output power greater than 10 milliwatts, the total antenna gain shall be added to the measured RF output power to demonstrate compliance to the specified radiated power limits.

Test Result:

The antenna is integral antenna, the best case gain of the antenna is 0.08dBi

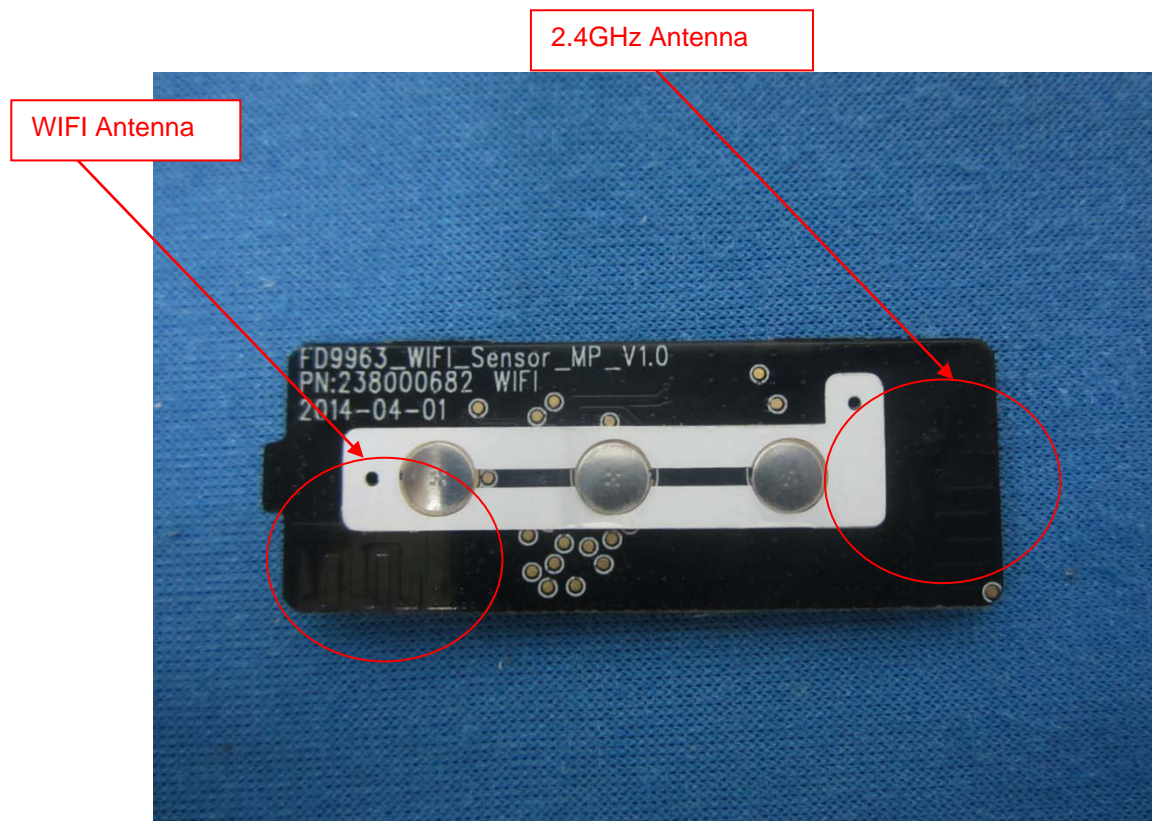

4.2. AC Conducted Emissions Test

TEST CONFIGURATION

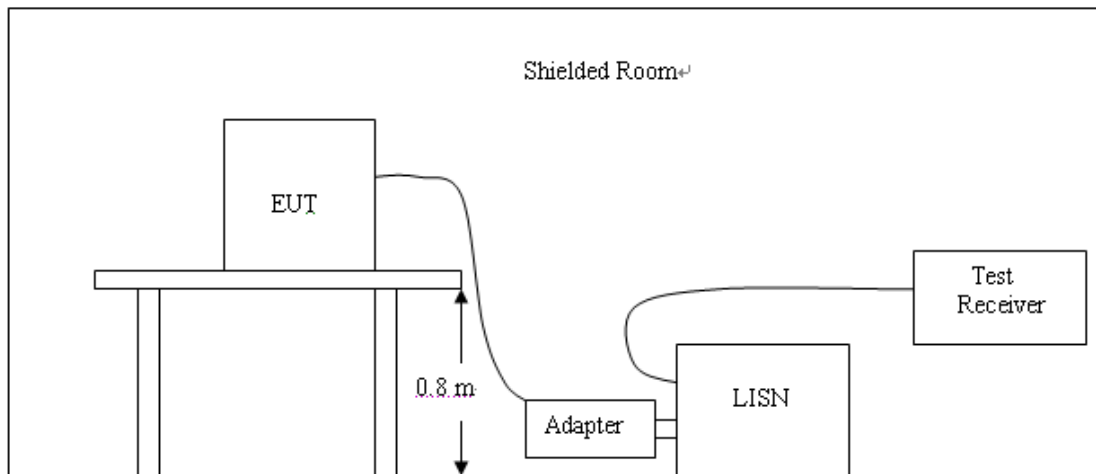

TEST PROCEDURE

1. The equipment was set up as per the test configuration to simulate typical actual usage per the user's manual. The EUT is a tabletop system, a wooden table with a height of 0.8 meters is used and is placed on the ground plane as per ANSI C63.4-2009.
2. Support equipment, if needed, was placed as per ANSI C63.4-2009
- 3 All I/O cables were positioned to simulate typical actual usage as per ANSI C63.4-2009
4. The EUT received DC5V power from USB and USB connect to PC,the adapter received AC120V/60Hz power through a Line Impedance Stabilization Network (LISN) which supplied power source and was grounded to the ground plane.
5. All support equipments received AC power from a second LISN, if any.
6. The EUT test program was started. Emissions were measured on each current carrying line of the EUT using a spectrum Analyzer / Receiver connected to the LISN powering the EUT. The LISN has two monitoring points: Line 1 (Hot Side) and Line 2 (Neutral Side). Two scans were taken: one with Line 1 connected to Analyzer / Receiver and Line 2 connected to a 50 ohm load; the second scan had Line 1 connected to a 50 ohm load and Line 2 connected to the Analyzer / Receiver.
7. Analyzer / Receiver scanned from 150 KHz to 30MHz for emissions in each of the test modes.
8. During the above scans, the emissions were maximized by cable manipulation.

CONDUCTED LIMIT

For intentional device, according to § 15.207(a) and RSS-Gen Section 7.2.4 for AC Power Conducted Emission Limits is as following:

Frequency (MHz)	Maximum RF Line Voltage (dBµV)			
	CLASS A		CLASS B	
	Q.P.	Ave.	Q.P.	Ave.
0.15 - 0.50	79	66	66-56*	56-46*
0.50 - 5.00	73	60	56	46
5.00 - 30.0	73	60	60	50

* Decreasing linearly with the logarithm of the frequency

TEST RESULTS

Test mode:	2.4GHz Transmitting	Polarization	L
------------	---------------------	--------------	---

SCAN TABLE: "Voltage (9K-30M)FIN"
 Short Description: 150K-30M Voltage

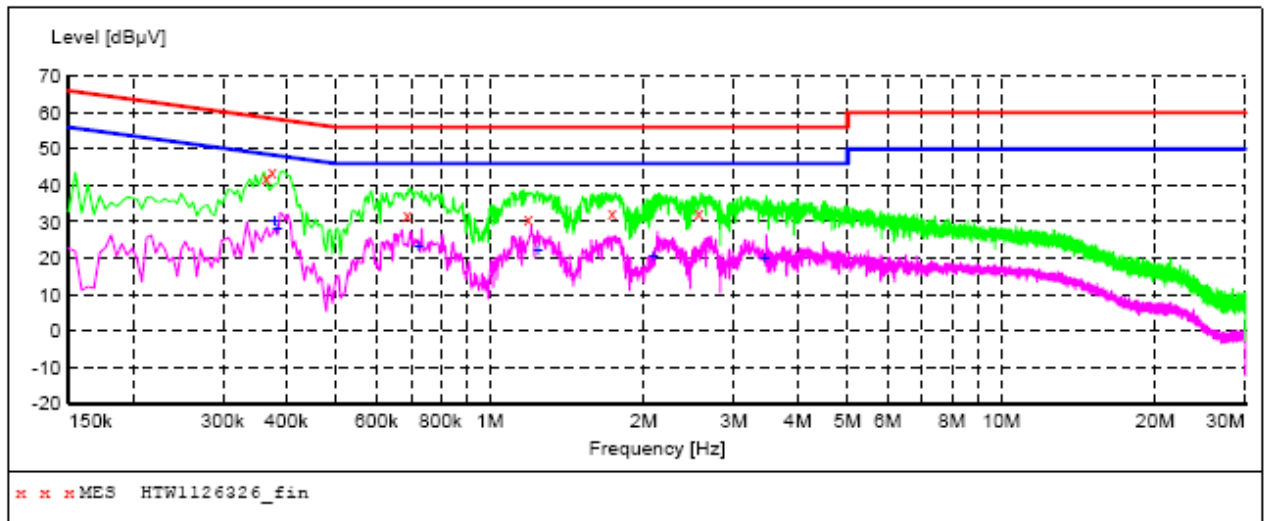

MEASUREMENT RESULT: "HTW1126326_fin"

5/26/2014 3:00PM

Frequency MHz	Level dBµV	Transd dB	Limit dBµV	Margin dB	Detector	Line	PE
0.366000	42.10	10.5	59	16.5	QP	L1	GND
0.375000	43.80	10.5	58	14.6	QP	L1	GND
0.690000	31.90	10.3	56	24.1	QP	L1	GND
1.189500	30.70	10.3	56	25.3	QP	L1	GND
1.734000	32.40	10.3	56	23.6	QP	L1	GND
2.562000	32.60	10.3	56	23.4	QP	L1	GND

MEASUREMENT RESULT: "HTW1126326_fin2"

5/26/2014 3:00PM

Frequency MHz	Level dBµV	Transd dB	Limit dBµV	Margin dB	Detector	Line	PE
0.379500	30.50	10.5	48	17.8	AV	L1	GND
0.384000	28.30	10.5	48	19.9	AV	L1	GND
0.726000	23.10	10.2	46	22.9	AV	L1	GND
1.243500	22.20	10.3	46	23.8	AV	L1	GND
2.094000	20.80	10.3	46	25.2	AV	L1	GND
3.453000	20.00	10.3	46	26.0	AV	L1	GND

Test mode:	2.4GHz Transmitting	Polarization	N
------------	---------------------	--------------	---

SCAN TABLE: "Voltage (9K-30M)FIN"

Short Description: 150K-30M Voltage

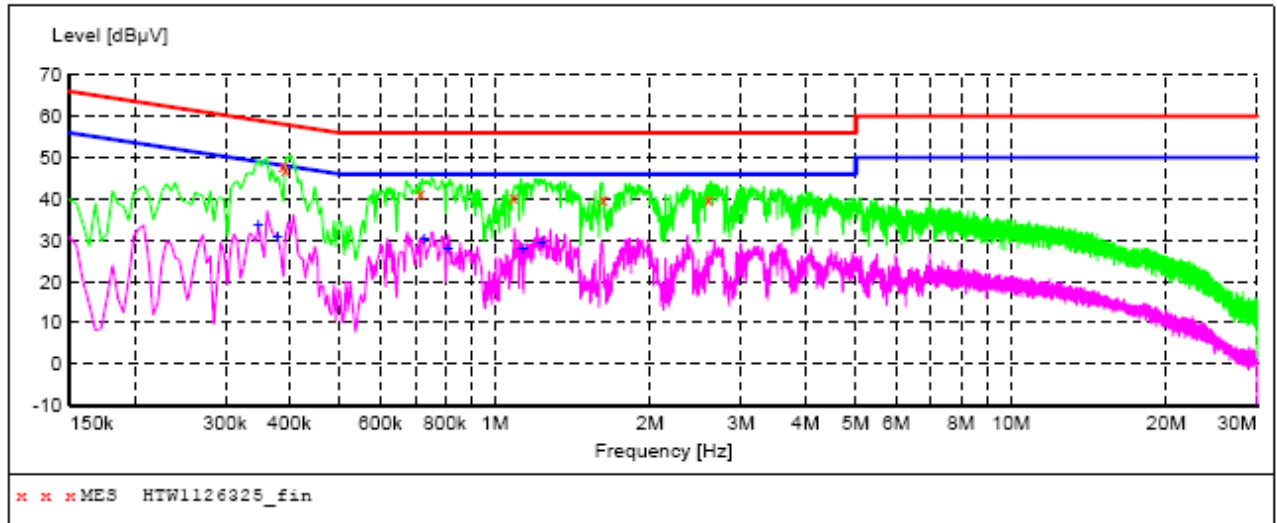

MEASUREMENT RESULT: "HTW1126325_fin"

5/26/2014 2:56PM

Frequency MHz	Level dBµV	Transd dB	Limit dBµV	Margin dB	Detector	Line	PE
0.388500	48.00	10.5	58	10.1	QP	N	GND
0.393000	47.00	10.5	58	11.0	QP	N	GND
0.717000	41.50	10.3	56	14.5	QP	N	GND
1.086000	40.40	10.3	56	15.6	QP	N	GND
1.621500	40.10	10.3	56	15.9	QP	N	GND
2.598000	40.20	10.3	56	15.8	QP	N	GND

MEASUREMENT RESULT: "HTW1126325_fin2"

5/26/2014 2:56PM

Frequency MHz	Level dBµV	Transd dB	Limit dBµV	Margin dB	Detector	Line	PE
0.348000	33.60	10.6	49	15.4	AV	N	GND
0.379500	30.90	10.5	48	17.4	AV	N	GND
0.730500	30.20	10.2	46	15.8	AV	N	GND
0.811500	27.90	10.2	46	18.1	AV	N	GND
1.135500	28.00	10.3	46	18.0	AV	N	GND
1.234500	29.40	10.3	46	16.6	AV	N	GND

4.3. Radiated Emission Test

TEST CONFIGURATION

Frequency range 9KHz – 30MHz

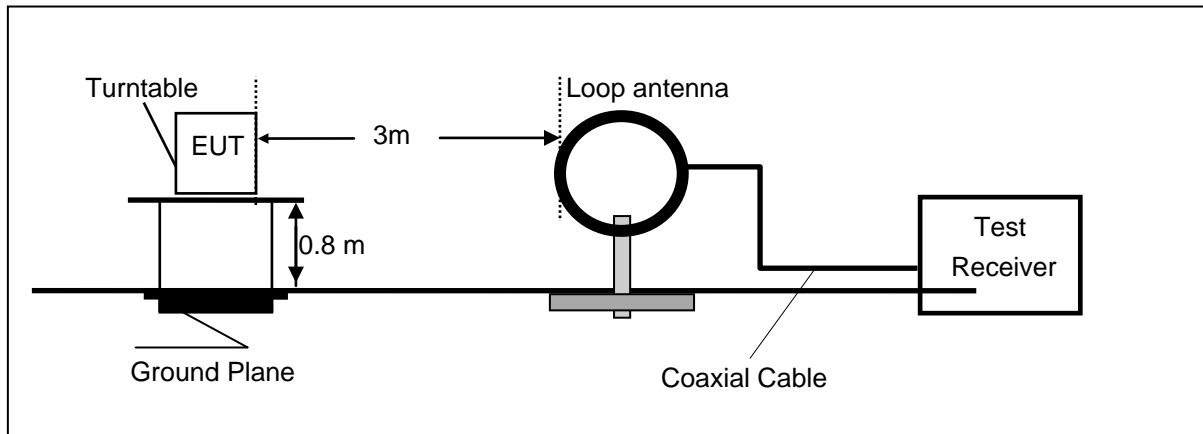

Frequency range 30MHz – 100MHz

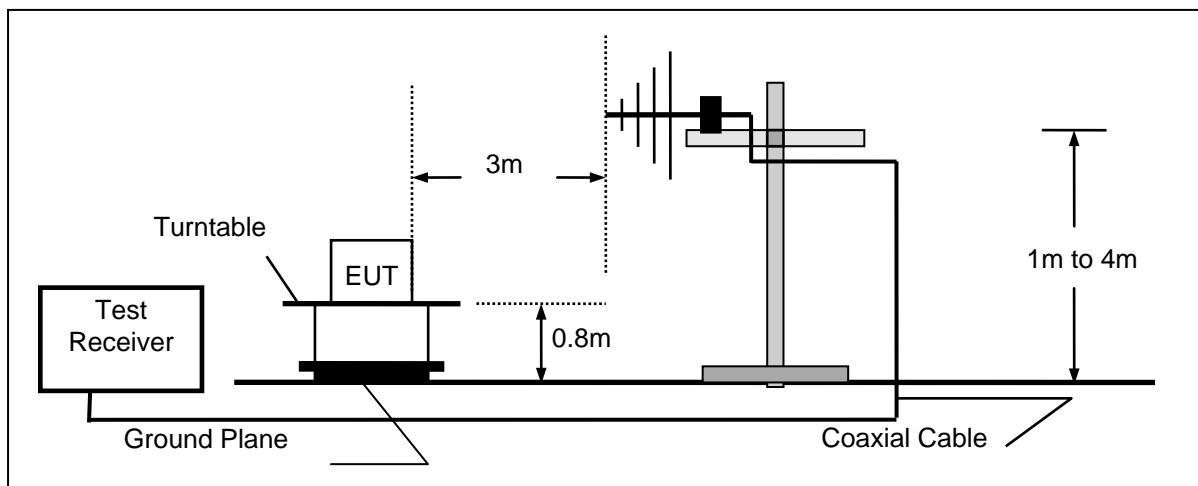

Frequency range above 1GHz-25GHz

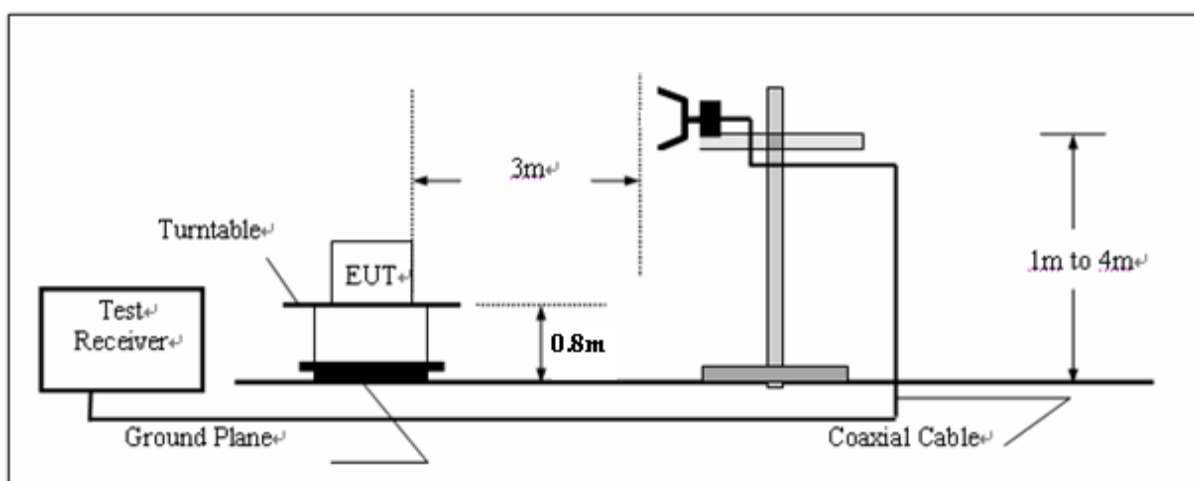

TEST PROCEDURE

1. The EUT is placed on a turntable, which is 0.8m above ground plane.
2. The turntable shall be rotated for 360 degrees to determine the position of maximum emission level.
3. EUT is set 3m away from the receiving antenna, which is varied from 1m to 4m to find out the highest emissions.
4. Maximum procedure was performed on the six highest emissions to ensure EUT compliance.

5. And also, each emission was to be maximized by changing the polarization of receiving antenna both horizontal and vertical.
6. Repeat above procedures until the measurements for all frequencies are complete.
7. The EUT minimum operation frequency was 26MHz and maximum operation frequency was 2430MHz.so radiated emission test frequency band from 9KHz to 25GHz.

Field Strength Calculation

The field strength is calculated by adding the Antenna Factor and Cable Factor and subtracting the Amplifier Gain and Duty Cycle Correction Factor(if any) from the measured reading. The basic equation with a sample calculation is as follows:

$$FS = RA + AF + CL + AG$$

Where FS = Field Strength	CL = Cable Attenuation Factor (Cable Loss)
RA = Reading Amplitude	AG = Amplifier Gain
AF = Antenna Factor	

RADIATION LIMIT

According to 15.249 (a): Except as provided in paragraph (b) of this section, the field strength of emissions from intentional radiators operated within these frequency bands shall comply with the following:

Fundamental frequency	Field strength of fundamental		Field strength of harmonics	
	millivolts/ meter	dBuV/m	microvolts/ meter	dBuV/m
902-928MHz	50	94.00	500	54.00
2400-2483.5MHz	50	94.00	500	54.00
5725-5875 MHz	50	94.00	500	54.00
24.0-24.25 GHz	250	108.00	2500	68.00

According to RSS-210 A2.9 (a): The field strength measured at 3 metres shall not exceed the limits in the following table:

Fundamental frequency	Field strength of fundamental		Field strength of harmonics	
	millivolts/ meter	dBuV/m	microvolts/ meter	dBuV/m
902-928MHz	50	94.00	500	54.00
2400-2483.5MHz	50	94.00	500	54.00
5725-5875 MHz	50	94.00	500	54.00

Note: The limits shown in the above table are based on measurements using an average detector, except for the fundamental emission in the frequency band 902-928 MHz, which is based on measurements using a CISPR quasi-peak detector.

The frequency spectrum above 1 GHz for Transmitter was investigated. All emission not reported are much lower than the prescribed limits. Set the RBW=1MHz,VBW=3MHz for Peak Detector while the RBW=1MHz,VBW=10Hz for Average Detector,Readings are both peak and average values.

For intentional device, according to § 15.209(a) and RSS-gen section 7.2.5 Table 5 the general requirement of field strength of radiated emissions from intentional radiators at a distance of 3 meters shall not exceed the following table.

Frequency(MHz)	Distance(Meters)	Radiated(dBuV/m)	Radiated(µV/m)
0.009-0.49	300	20log(2400/F(KHz))	2400/F(KHz)
0.49-1.705	30	20log(24000/F(KHz))	24000/F(KHz)
1.705-30	30	20log(30)	30
30-88	3	40.0	100
88-216	3	43.5	150
216-960	3	46.0	200
Above 960	3	54.0	500

TEST RESULTS

Remark:

1. ULTRA-BROADBAND ANTENNA for the radiation emission test below 1G.
2. HORN ANTENNA for the radiation emission test above 1G.
3. We tested three orientations,recored woest case for results.

For 2430MHz

Frequency (MHz)	Level (dBuV/m)	Cable Loss (dB)	Antenna Factor (dB/m)	Preamp Factor (dB)	Reading Level (dBuV/m)	Limit (dBuV/m)	Margin (dB)	Antenna Polarization	Detector
2430.00	92.42	27.45	3.83	36.55	87.15	114.00	26.85	Hor	Peak
2430.00	90.62	27.45	3.83	36.55	85.35	94.00	8.65	Hor	Average
2430.00	95.43	27.45	3.83	36.55	90.16	114.00	23.84	Ver	Peak
2430.00	91.79	27.45	3.83	36.55	86.52	94.00	7.48	Ver	Average

For 9KHz to 30MHz

Frequency (MHz)	Corrected Reading (dB μ V/m)@3m	FCC Limit (dB μ V/m) @3m	Margin (dB)	Detector	Result
13.25	43.89	69.54	25.65	QP	PASS
23.35	42.54	69.58	27.04	QP	PASS

Measurement data:**■ Below 1GHz**

Frequency (MHz)	Read Level (dBuV)	Antenna Factor (dB/m)	Cable Loss (dB)	Preamp Factor (dB)	Level (dBuV/m)	Limit Line (dBuV/m)	Over Limit (dB)	Polarization
32.38	27.34	21.5	0.6	32.06	17.38	40	22.62	Vertical
89.95	39.79	11.88	0.96	31.84	20.79	40	19.21	Vertical
96.79	39.06	12.09	1.16	31.75	20.56	43.5	22.94	Vertical
196.86	38.69	11.42	1.55	31.97	19.69	46	26.31	Vertical
535.15	50.44	18.8	2.06	32.16	39.14	46	6.86	Vertical
863.97	46.09	23.04	4.96	31.2	42.89	46	3.11	Vertical
32.38	29.54	21.5	0.6	32.06	19.58	40	20.42	Horizontal
89.95	40.76	11.88	0.96	31.84	21.76	40	18.24	Horizontal
96.79	41.45	12.09	1.16	31.75	22.95	40	17.05	Horizontal
196.86	38.78	11.42	1.55	31.97	19.78	40	20.22	Horizontal
535.15	46.4	18.8	2.06	32.16	35.1	47	11.9	Horizontal
863.97	44.58	23.04	4.96	31.2	41.38	47	5.62	Horizontal

■ Above 1GHz

Peak value:

Frequency (MHz)	Read Level (dBuV)	Antenna Factor (dB/m)	Cable Loss (dB)	Preamp Factor (dB)	Level (dBuV/m)	Limit Line (dBuV/m)	Over Limit (dB)	Polarization
4860	44.28	30.88	5.7	35.27	45.59	74	28.41	Vertical
7290	39.04	35.82	6.91	35.13	46.64	74	27.36	Vertical
9720	34.83	37.45	8.84	35.53	45.59	74	28.41	Vertical
12150	*					74		Vertical
14580	*					74		Vertical
4860	42.27	30.88	5.7	35.27	43.58	74	30.42	Horizontal
7290	36.09	35.82	6.91	35.13	43.69	74	30.31	Horizontal
9720	33.13	37.45	8.84	35.53	43.89	74	30.11	Horizontal
12150	*					74		Horizontal
14580	*					74		Horizontal

Average value:

Frequency (MHz)	Read Level (dBuV)	Antenna Factor (dB/m)	Cable Loss (dB)	Preamp Factor (dB)	Level (dBuV/m)	Limit Line (dBuV/m)	Over Limit (dB)	Polarization
4860	31.07	30.88	5.7	35.27	32.38	54	21.62	Vertical
7290	25.86	35.82	6.91	35.13	33.46	54	20.54	Vertical
9720	22.09	37.45	8.84	35.53	32.85	54	21.15	Vertical
12150	*					54		Vertical
14580	*					54		Vertical
4860	31.38	30.88	5.7	35.27	32.69	54	21.31	Horizontal
7290	25.25	35.82	6.91	35.13	32.85	54	21.15	Horizontal
9720	20.58	37.45	8.84	35.53	31.34	54	22.66	Horizontal
12150	*					54		Horizontal
14580	*					54		Horizontal

- REMARKS:**
1. Emission level (dBuV/m)=Raw Value(dBuV)+Correction Factor(dB/m)
 2. Correction Factor (dB/m) = Antenna Factor (dB/m)+Cable Factor (dB)-Pre-amplifier Factor
 3. The other emission levels were very low against the limit.
 4. Margin value = Limit value- Emission level.
 5. The limit value is defined as per 15.249

4.4. Out of band emissions

TEST PROCEDURE

The band edge compliance of RF radiated emission should be measured by following the guidance in ANSI C63.4 with respect to maximizing the emission by rotating the EUT, measuring the emission while the EUT is situated in three orthogonal planes (if appropriate), adjusting the measurement antenna height and polarization etc. Set RBW to 1MHz and VBM to 3MHz to measure the peak field strength and set RBW to 1MHz and VBW to 10Hz to measure the average radiated field strength. The conducted RF band edge was measured by using a spectrum analyzer. Set span wide enough to capture the highest in-band emission and the emission at the band edge. Set RBW to 100 KHz and VBM to 300 KHz, to measure the conducted peak band edge.

TEST CONFIGURATION

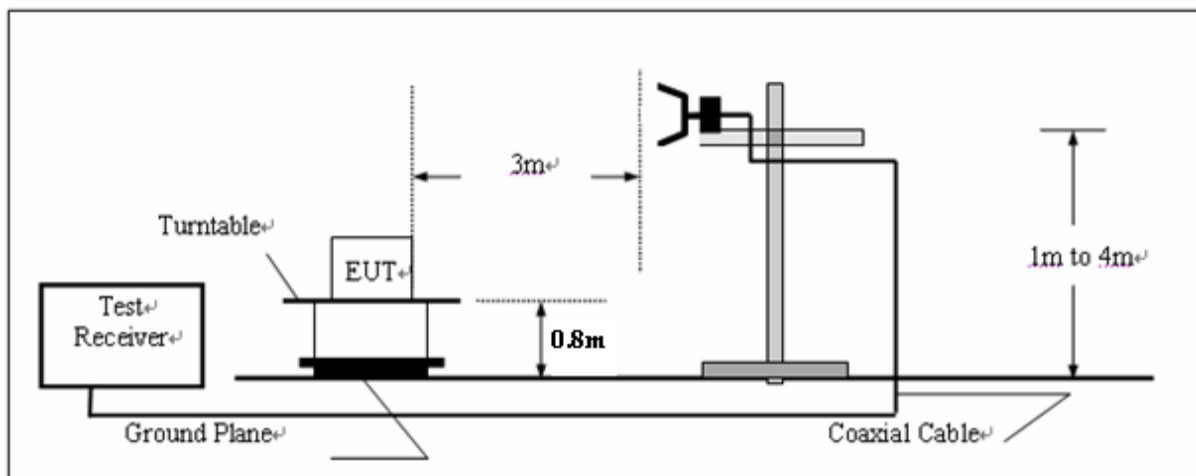

LIMIT

FCC PART 15.249(d) Emissions radiated outside of the specified frequency bands, except for harmonics, shall be attenuated by at least 50 dB below the level of the fundamental or to the general radiated emission limits in §15.209, whichever is the lesser attenuation.

According to RSS-210 A2.9 (b): Emissions radiated outside of the specified frequency bands, except for harmonics, shall be attenuated by at least 50 dB below the level of the fundamental or to the general field strength limits listed in RSS-Gen, whichever is less stringent.

TEST RESULTS

Measurement data:**Peak value:**

Frequency (MHz)	Read Level (dBuV)	Factor (dB/m)	Level (dBuV/m)	Limit Line (dBuV/m)	Over Limit (dB)	Polarization
2390.00	50.40	-5.28	45.12	74.00	28.88	Vertical
2483.50	50.76	-5.22	45.54	74.00	28.46	Vertical
2390.00	47.40	-5.28	42.12	74.00	31.88	Horizontal
2483.50	50.84	-5.22	45.62	74.00	28.38	Horizontal

Average value:

Frequency (MHz)	Read Level (dBuV)	Antenna Factor (dB/m)	Level (dBuV/m)	Limit Line (dBuV/m)	Over Limit (dB)	Polarization
2390.00	44.07	-5.28	38.79	54.00	15.21	Vertical
2483.50	45.58	-5.22	40.36	54.00	13.64	Vertical
2389.52	43.30	-5.28	38.02	54.00	15.98	Horizontal
2483.50	43.43	-5.22	38.21	54.00	15.79	Horizontal

- REMARKS:**
1. Emission level (dBuV/m)=Raw Value(dBuV)+Correction Factor(dB/m)
 2. Correction Factor (dB/m) = Antenna Factor (dB/m)+Cable Factor (dB)-Pre-amplifier Factor
 3. The other emission levels were very low against the limit.
 4. Margin value = Limit value- Emission level.
 5. The limit value is defined as per 15.249

4.5. 20dB Bandwidth and 99% Occupancy Bandwidth Measurement

TEST CONFIGURATION

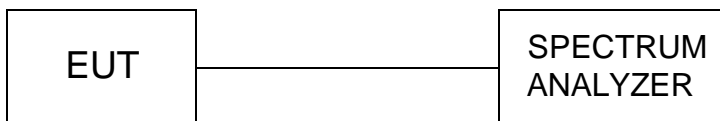

TEST PROCEDURE

The transmitter output is connected to the spectrum analyzer. The spectrum analyzer center frequency is set to the transmitter frequency. The RBW is set to 100 KHz and VBW is set 300 KHz.

LIMIT

Intentional radiators operating under the alternative provisions to the general emission limits, as contained in §§ 15.217 through 15.257 and in Subpart E of this part, must be designed to ensure that the 20 dB bandwidth of the emission, or whatever bandwidth may otherwise be specified in the specific rule section under which the equipment operates, is contained within the frequency band designated in the rule section under which the equipment is operated.

TEST RESULTS

Operating Frequency (MHz)	20dB Bandwidth Results (MHz)	99% Bandwidth Results (MHz)	Limits (MHz)		Result
2430	1.413	1.336	>2400	<2483.5	PASS

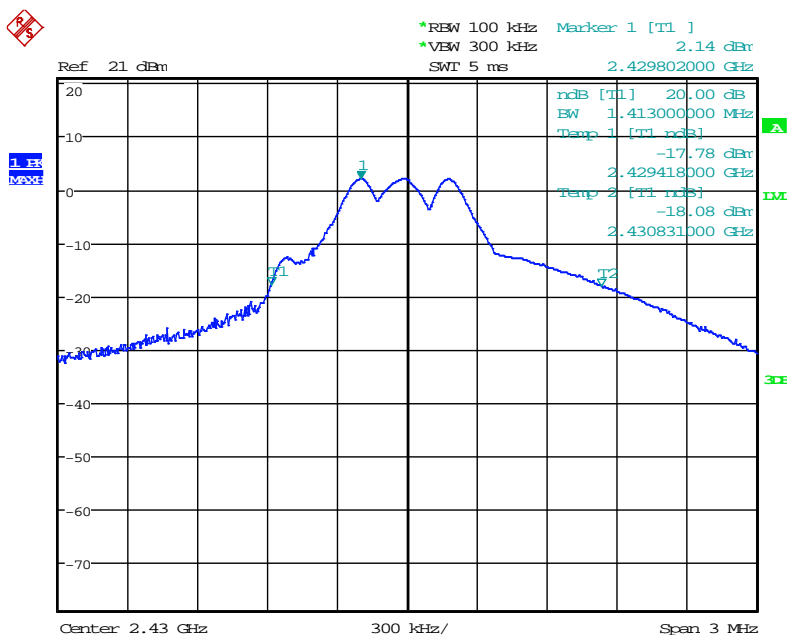

Date: 26.MAY.2014 17:47:49

20dB bandwidth

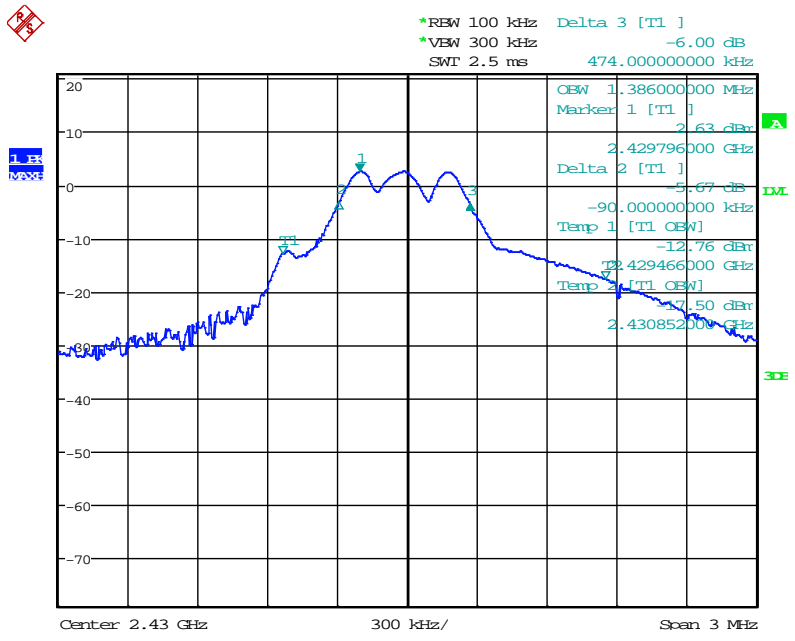

Date: 26.MAY.2014 21:09:44

99% Occupancy bandwidth

5. Test Setup Photos of the EUT

Radiated Emission (30MHz-1GHz)



Radiated Emission (above 1GHz)



Radiated Emission (Below 30MHz)



Conducted Emission (AC Mains)



6. External and Internal Photos of the EUT

External Photos





Internal Photos

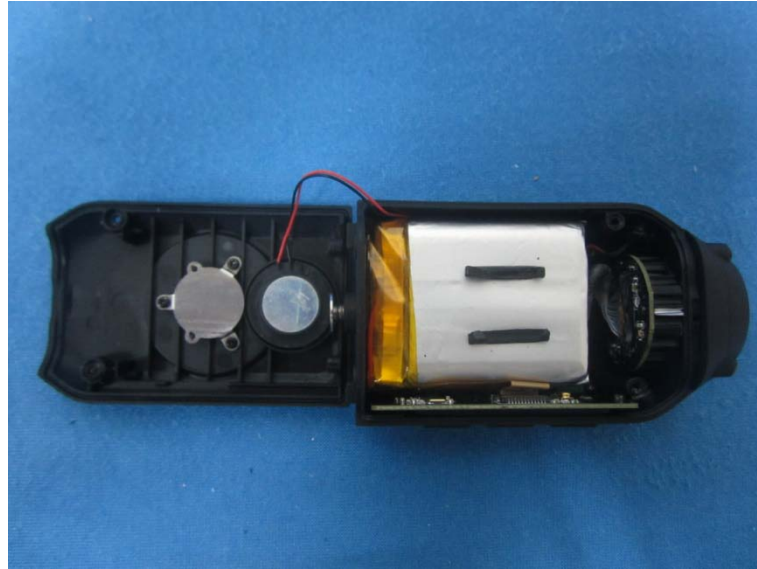

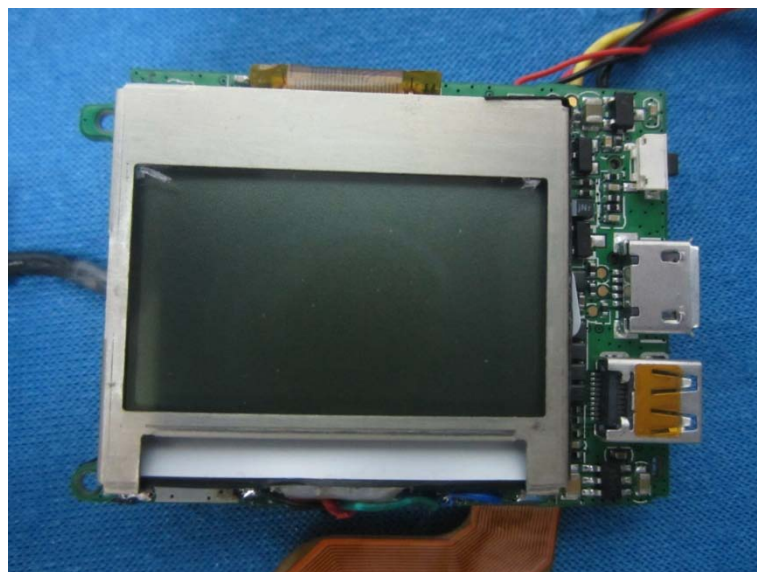
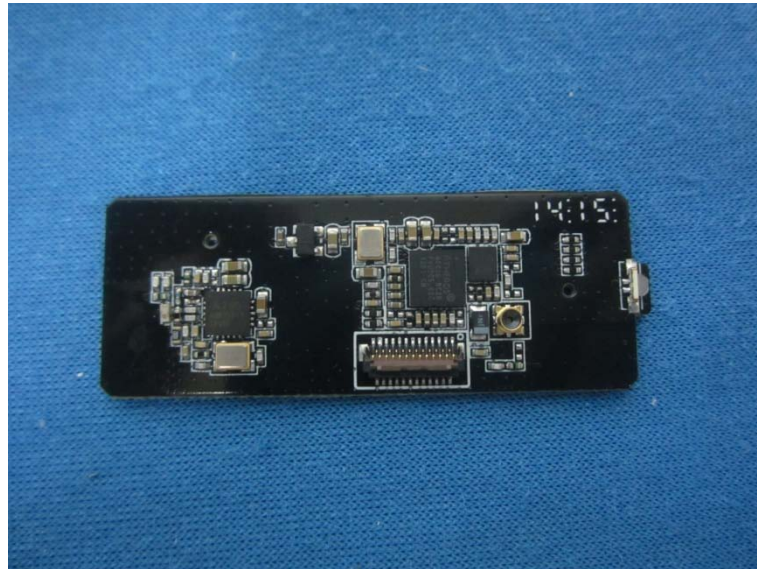

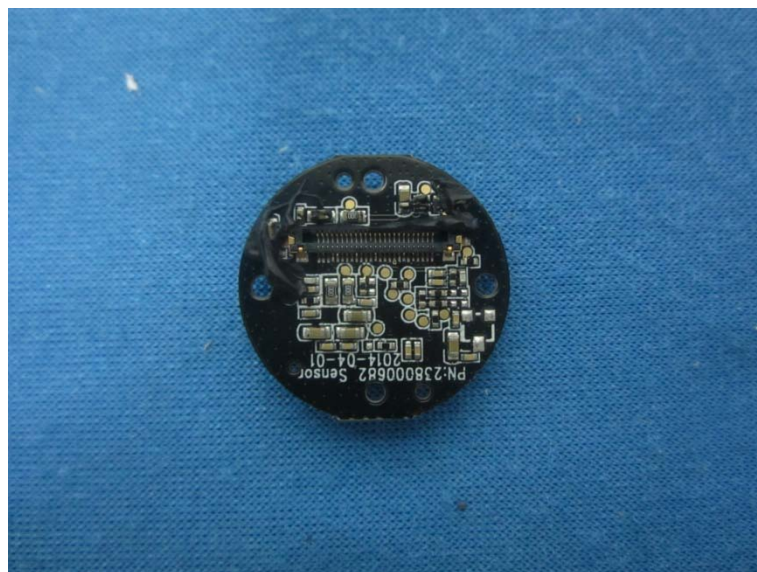
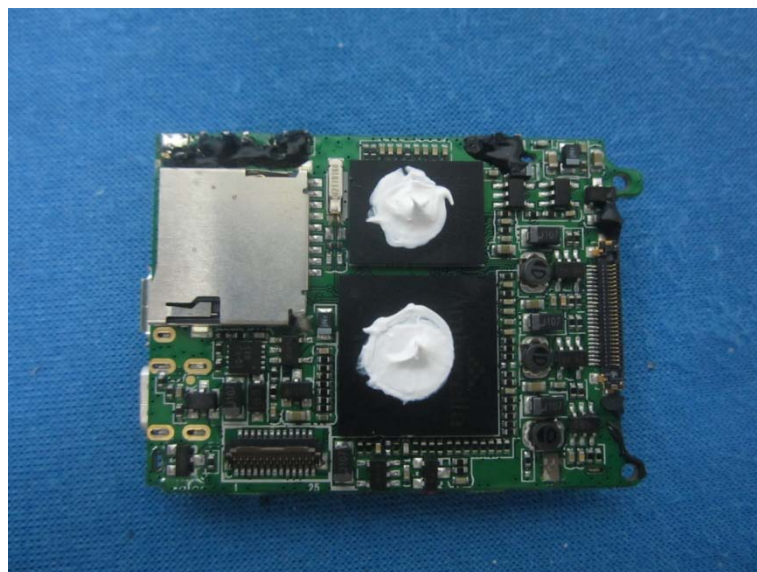
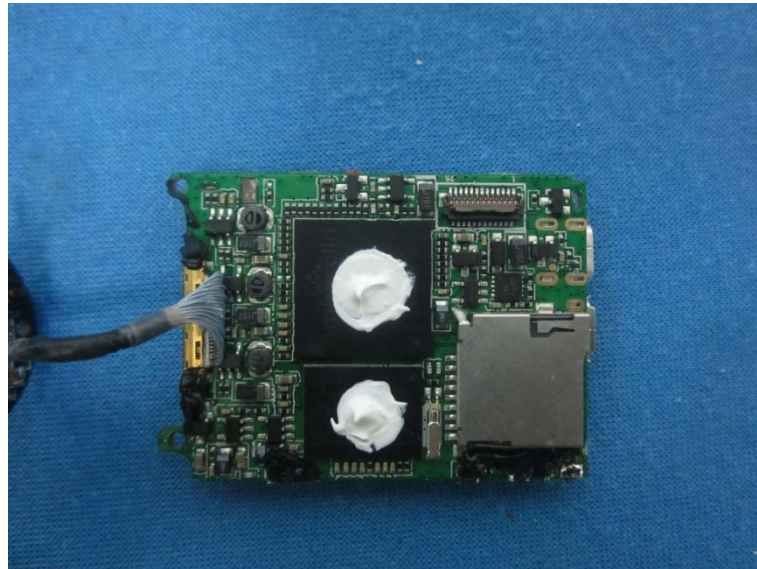

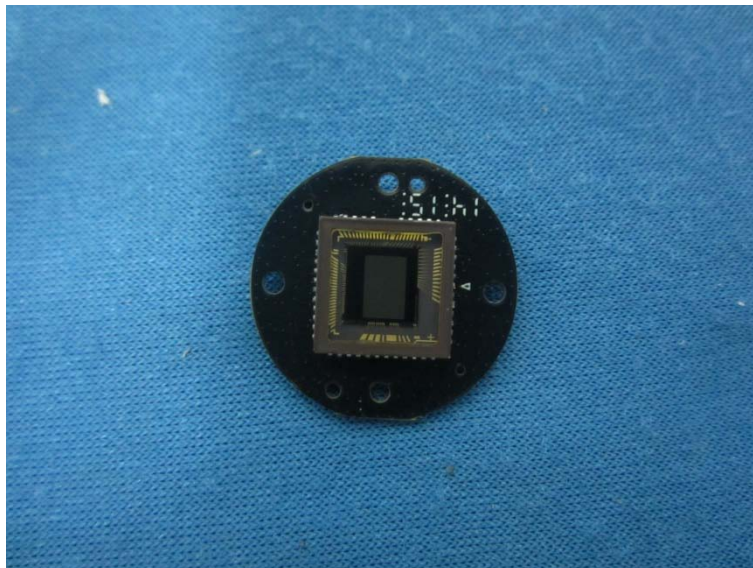

.....End of Report.....