

FCC PART 15.249

TEST REPORT

For

Drift Innovation Ltd.

The Light Box Unit 125, 111 Power Road, London, UK.

FCC ID: P2F-DI-RC505

Report Type: Original Report	Product Type: Drift 2-Way Remote Control
Test Engineer: Mick Yin	<i>Mick Yin</i>
Report Number: RSZ120917005-00R	
Report Date: 2012-10-15	
Reviewed By: Sula Huang RF Engineer	<i>Sula Huang</i>
Test Laboratory:	Bay Area Compliance Laboratories Corp. (Shenzhen) 6/F, the 3rd Phase of WanLi Industrial Building ShiHua Road, FuTian Free Trade Zone Shenzhen, Guangdong, China Tel: +86-755-33320018 Fax: +86-755-33320008 www.baclcorp.com.cn

Note: This test report is prepared for the customer shown above and for the device described herein. It may not be duplicated or used in part without prior written consent from Bay Area Compliance Laboratories Corp. (Shenzhen). This report **must not** be used by the customer to claim product certification, approval, or endorsement by NVLAP*, NIST, or any agency of the Federal Government.

* This report may contain data that are not covered by the NVLAP accreditation and shall be marked with an asterisk "★"

TABLE OF CONTENTS

GENERAL INFORMATION.....	3
PRODUCT DESCRIPTION FOR EQUIPMENT UNDER TEST (EUT)	3
OBJECTIVE	3
RELATED SUBMITTAL(S)/GRANT(S).....	3
TEST METHODOLOGY	3
TEST FACILITY	3
SYSTEM TEST CONFIGURATION.....	5
JUSTIFICATION	5
EUT EXERCISE SOFTWARE	5
EQUIPMENT MODIFICATIONS	5
SUPPORT EQUIPMENT LIST AND DETAILS	5
EXTERNAL I/O CABLE.....	5
BLOCK DIAGRAM OF TEST SETUP	6
SUMMARY OF TEST RESULTS	7
FCC§15.203 - ANTENNA REQUIREMENT.....	8
APPLICABLE STANDARD	8
ANTENNA CONNECTOR CONSTRUCTION	8
FCC §15.207 (A) – AC LINE CONDUCTED EMISSIONS	9
APPLICABLE STANDARD	9
MEASUREMENT UNCERTAINTY	9
EUT SETUP	9
EMI TEST RECEIVER SETUP.....	10
TEST EQUIPMENT LIST AND DETAILS.....	10
TEST PROCEDURE	10
TEST RESULTS SUMMARY.....	10
TEST DATA	10
FCC§15.205, §15.209&§15.249- RADIATED EMISSIONS	13
APPLICABLE STANDARD	13
MEASUREMENT UNCERTAINTY	13
TEST EQUIPMENT SETUP.....	13
EUT SETUP.....	14
TEST PROCEDURE	14
CORRECTED AMPLITUDE & MARGIN CALCULATION	14
TEST EQUIPMENT LIST AND DETAILS.....	15
TEST RESULTS SUMMARY.....	15
TEST DATA	15
FCC§15.249(D) - OUT OF BAND EMISSION (50DB ATTENUATION)	17
APPLICABLE STANDARD	17
TEST PROCEDURE	17
TEST EQUIPMENT LIST AND DETAILS.....	17
TEST DATA	17

GENERAL INFORMATION

Product Description for Equipment under Test (EUT)

The *Drift Innovation Ltd.*'s product, model number: *DI-RC505 (FCC ID: P2F-DI-RC505)* or the "EUT" in this report was a *Drift 2-Way Remote Control*, which was measured approximately: 5.9 cm (L) x 4.8 cm (W) x 1.2 cm (H), rated input voltage: DC 3.7V Li-ion battery or DC 5V charging from USB port..

** All measurement and test data in this report was gathered from production sample serial number: 1209071 (Assigned by BACL, Shenzhen). The EUT was received on 2012-09-17.*

Objective

This report is prepared on behalf of *Drift Innovation Ltd.* in accordance with Part 2-Subpart J, and Part 15-Subparts A, B and C of the Federal Communication Commissions rules.

The tests were performed in order to determine compliance with FCC Part 15, Subpart C, and section 15.203, 15.205, 15.207, 15.209 and 15.249 rules.

Related Submittal(s)/Grant(s)

FCC part 15.249 DXX and FCC part 15.247 DTS submissions of camera unit with ID: P2FF9935

Test Methodology

All measurements contained in this report were conducted with ANSI C63.4-2009, American National Standard for Methods of Measurement of Radio-Noise Emissions from Low-Voltage Electrical and Electronic Equipment in the range of 9 kHz to 40 GHz.

All radiated and conducted emissions measurement was performed at Bay Area Compliance Laboratories Corp. (Shenzhen). The radiated testing was performed at an antenna-to-EUT distance of 3 meters.

Test Facility

The Test site used by Bay Area Compliance Laboratories Corp. (Shenzhen) to collect test data is located on the 6/F, the 3rd Phase of WanLi Industrial Building, ShiHua Road, FuTian Free Trade Zone Shenzhen, Guangdong, China.

Test site at Bay Area Compliance Laboratories Corp. (Shenzhen) has been fully described in reports submitted to the Federal Communication Commission (FCC). The details of these reports have been found to be in compliance with the requirements of Section 2.948 of the FCC Rules on December 06, 2010. The facility also complies with the radiated and AC line conducted test site criteria set forth in ANSI C63.4-2009.

The Federal Communications Commission has the reports on file and is listed under FCC Registration No.: 382179. The test site has been approved by the FCC for public use and is listed in the FCC Public Access Link (PAL) database.

Additionally, Bay Area Compliance Laboratories Corp. (Shenzhen) is an ISO/IEC 17025 accredited laboratory, and is accredited by National Voluntary Laboratory Accredited Program (Lab Code 200707-0).



The current scope of accreditations can be found at <http://ts.nist.gov/Standards/scopes/2007070.htm>

SYSTEM TEST CONFIGURATION

Justification

The system was configured for testing in a typical fashion (as normally used by a typical user).

EUT Exercise Software

No exercise software.

Equipment Modifications

No modification was made to the EUT tested.

Support Equipment List and Details

Manufacturer	Description	Model	Serial Number
DELL	PC	VOSTRO 220S	127BP2X
DELL	Keyboard	L100	CNORH656658907BL05DC
DELL	Mouse	MOC5UO	G1900NKD
DELL	LCD Monitor	E178WFPC	CN-OWY564-64180-7C4-2SQH

External I/O Cable

Cable Description	Length (m)	From/Port	To
Shielded Detachable USB Cable	1.5	Host PC	Mouse
Shielded Detachable K/B Cable	1.5	Host PC	Keyboard
Shielded Detachable VGA Cable	1.8	Host PC	LCD Monitor
Unshielded Detachable USB Cable with core	0.6	EUT	Host PC

Block Diagram of Test Setup

AC Line Conducted Emission:

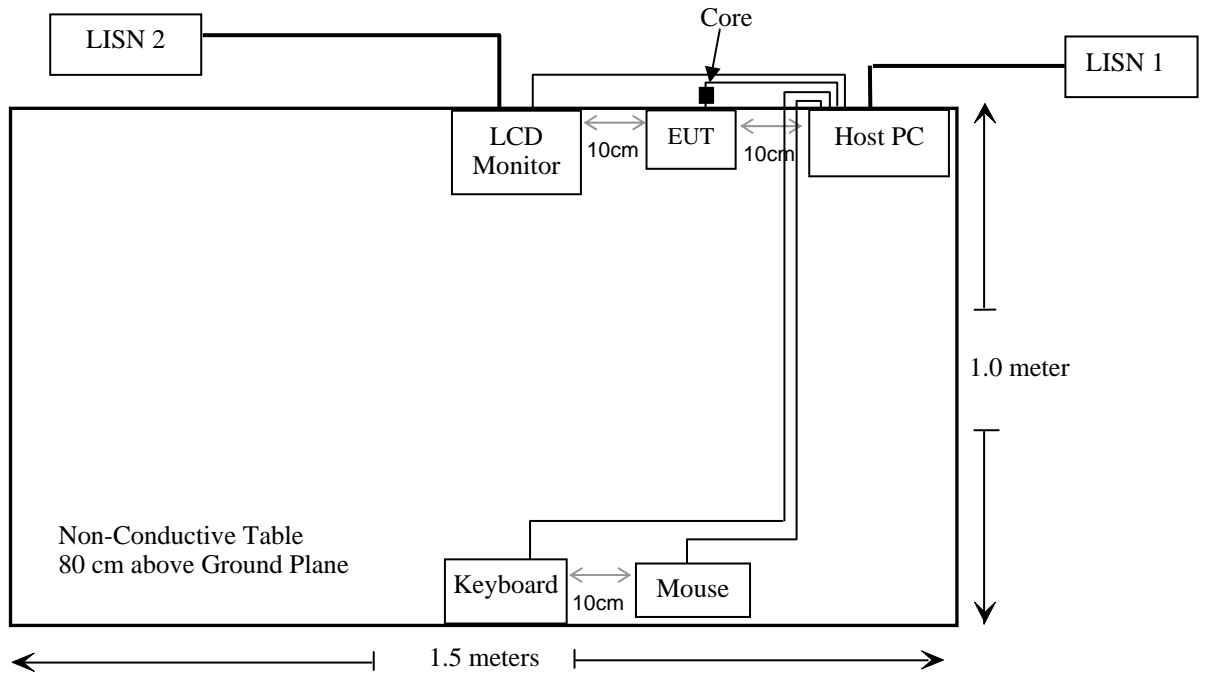

Radiated Emission:

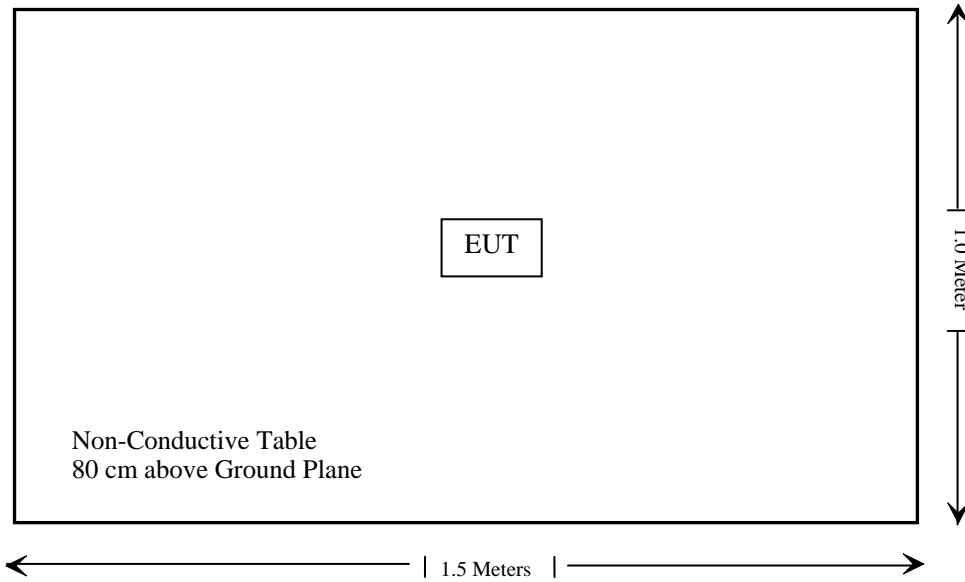

SUMMARY OF TEST RESULTS

FCC Rules	Description of Test	Result
§15.203	Antenna Requirement	Compliance
§15.207(a)	Conducted Emissions	Compliance
15.205, §15.209, §15.249	Radiated Emissions	Compliance
§15.249(d)	Outside of Band Emission-50dB attenuation	Compliance

FCC§15.203 - ANTENNA REQUIREMENT

Applicable Standard

For intentional device, according to §15.203, an intentional radiator shall be designed to ensure that no antenna other than that furnished by the responsible party shall be used.

Antenna Connector Construction

The EUT has an integrated antenna arrangement, which was permanently attached and the gain was 0 dBi, fulfill the requirement of this section. Please refer to EUT photos.

Result: Compliant

FCC §15.207 (a) – AC LINE CONDUCTED EMISSIONS

Applicable Standard

FCC §15.207

Measurement Uncertainty

All measurements involve certain levels of uncertainties, especially in field of EMC. The factors contributing to uncertainties are spectrum analyzer, cable loss, and LISN.

Based on CISPR 16-4-4, The Treatment of Uncertainty in EMC Measurements, the best estimate of the uncertainty of any conducted emissions measurement at Bay Area Compliance Laboratory Corp. (Shenzhen) is 2.4 dB (k=2, 95% level of confidence), and the uncertainty will not be taken into consideration for all the test data recorded in the report.

EUT Setup

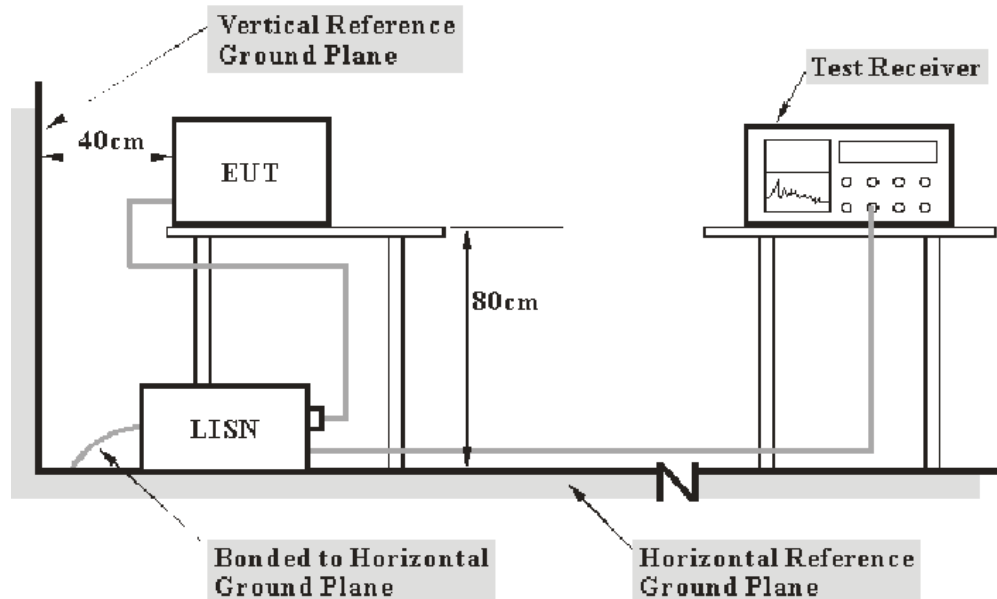

- Note:**
1. Support units were connected to second LISN.
 2. Both of LISNs (AMN) 80 cm from EUT and at the least 80 cm from other units and other metal planes support units.

The setup of EUT is according with per ANSI C63.4-2009 measurement procedure. The specification used was with the FCC Part 15.207 limits.

The host PC was connected to a 120 VAC/60 Hz power source.

EMI Test Receiver Setup

The EMI test receiver was set to investigate the spectrum from 150 kHz to 30 MHz.

During the conducted emission test, the EMI test receiver was set with the following configurations:

<i>Frequency Range</i>	<i>IF B/W</i>
150 kHz – 30 MHz	9 kHz

Test Equipment List and Details

Manufacturer	Description	Model	Serial Number	Calibration Date	Calibration Due Date
Rohde & Schwarz	EMI Test Receiver	ESCS30	100176	2011-11-24	2012-11-23
Rohde & Schwarz	L.I.S.N.	ESH2-Z5	892107/021	2011-11-17	2012-11-16
Com-Power	L.I.S.N.	LI-200	12005	N/A	N/A
Com-Power	L.I.S.N.	LI-200	12208	N/A	N/A
Rohde & Schwarz	Pulse limiter	ESH3Z2	DE25985	2012-07-08	2013-07-07
BACL	CE Test software	BACL-CE	V1.0	N/A	N/A

* **Statement of Traceability:** Bay Area Compliance Laboratory Corp. (Shenzhen) attests that all calibrations have been performed in accordance to NVLAP requirements, traceable to the NIST.

Test Procedure

During the conducted emission test, the host PC was connected to the outlet of the first LISN, and the other relevant equipments were connected to the second LISN.

Maximizing procedure was performed on the six (6) highest emissions of the EUT.

All data was recorded in the Quasi-peak and average detection mode.

Test Results Summary

According to the recorded data in following table, the EUT complied with the FCC Part 15.207, with the worst margin reading of:

9.03 dB at 9.255 MHz in the Neutral conducted mode

Test Data

Environmental Conditions

Temperature:	25 °C
Relative Humidity:	48 %
ATM Pressure:	100.0 kPa

The testing was performed by Mick Yin on 2012-09-19.

EUT Operation Mode: Charging

AC 120V/60 Hz, Line

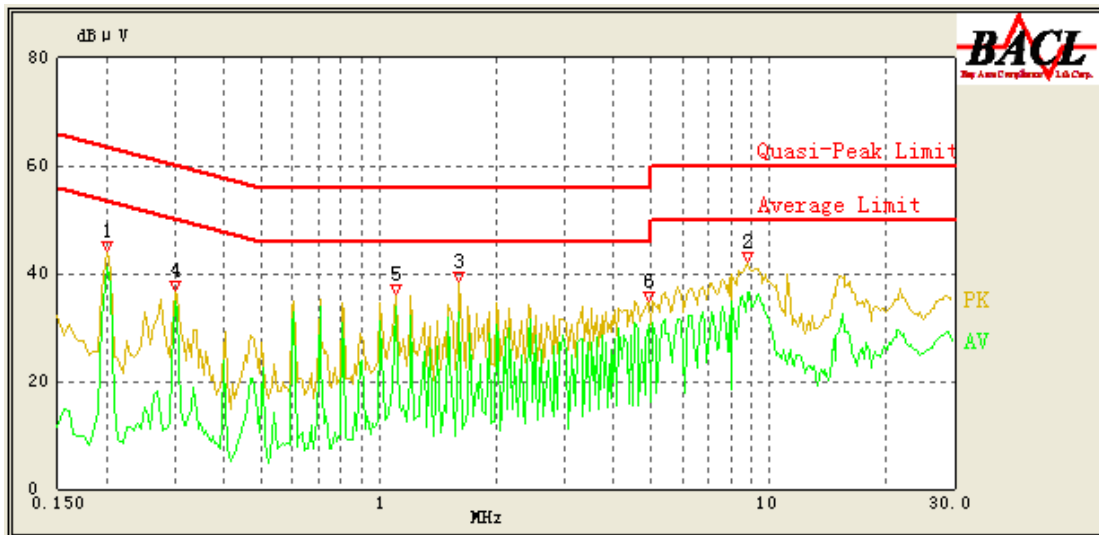

Frequency (MHz)	Corrected Amplitude (dBμV)	Correction Factor (dB)	Limit (dBμV)	Margin (dB)	Detector (PK/Ave./QP)
1.105	33.85	10.17	46.00	12.15	Ave.
1.610	32.72	10.19	46.00	13.28	Ave.
8.850	36.50	10.45	50.00	13.50	Ave.
0.200	41.03	10.27	54.57	13.54	Ave.
4.930	30.41	10.30	46.00	15.59	Ave.
0.300	34.84	10.26	51.71	16.87	Ave.
1.610	35.01	10.19	56.00	20.99	QP
1.105	34.25	10.17	56.00	21.75	QP
0.200	42.45	10.27	64.57	22.12	QP
8.845	37.82	10.45	60.00	22.18	QP
4.930	32.58	10.30	56.00	23.42	QP
0.300	34.91	10.26	61.71	26.80	QP

AC 120V/60 Hz, Neutral

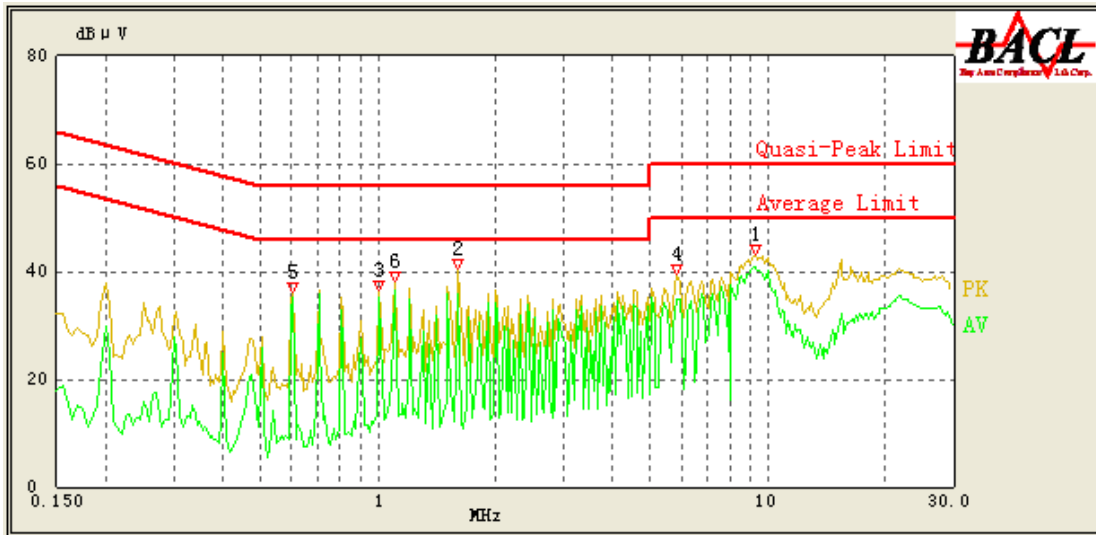

Frequency (MHz)	Corrected Amplitude (dBμV)	Correction Factor (dB)	Limit (dBμV)	Margin (dB)	Detector (PK/Ave./QP)
9.255	40.97	10.46	50.00	9.03	Ave.
1.105	36.40	10.17	46.00	9.60	Ave.
1.610	35.81	10.19	46.00	10.19	Ave.
1.005	35.08	10.17	46.00	10.92	Ave.
0.605	35.01	10.23	46.00	10.99	Ave.
5.835	34.87	10.32	50.00	15.13	Ave.
9.255	41.56	10.46	60.00	18.44	QP
1.610	37.49	10.19	56.00	18.51	QP
1.105	37.36	10.17	56.00	18.64	QP
1.005	35.81	10.17	56.00	20.19	QP
0.605	35.09	10.23	56.00	20.91	QP
5.835	37.54	10.32	60.00	22.46	QP

Note:

- 1) Corrected Amplitude = Reading + Correction Factor
- 2) Correction Factor = LISN/ISN VDF (Voltage Division Factor) + Cable Loss + Pulse Limiter Attenuation
The corrected factor has been input into the transducer of the test software.
- 3) Margin = Limit – Corrected Amplitude

FCC§15.205, §15.209&§15.249- RADIATED EMISSIONS

Applicable Standard

As per FCC§15.249 (a), except as provided in paragraph (b) of this section, the field strength of emissions from intentional radiators operated within these frequency bands shall comply with the following:

Fundamental frequency	Field strength of fundamental (millivolts/meter)	Field strength of harmonics (microvolts/meter)
902–928 MHz	50	500
2400–2483.5 MHz	50	500
5725–5875 MHz	50	500
24.0–24.25 GHz	250	2500

As per FCC§15.249 (c), Field strength limits are specified at a distance of 3 meters.

(d) Emissions radiated outside of the specified frequency bands, except for harmonics, shall be attenuated by at least 50 dB below the level of the fundamental or to the general radiated emission limits in §15.209, whichever is the lesser attenuation.

Measurement Uncertainty

All measurements involve certain levels of uncertainties, especially in field of EMC. The factors contributing to uncertainties are spectrum analyzer, cable loss, antenna factor calibration, antenna directivity, antenna factor variation with height, antenna phase center variation, antenna factor frequency interpolation, measurement distance variation, site imperfections, mismatch (average), and system repeatability.

Based on CISPR 16-4-4, The Treatment of Uncertainty in EMC Measurements, the best estimate of the uncertainty of a radiation emissions measurement at Bay Area Compliance Laboratories Corp. (Shenzhen) is 4.0 dB. (k=2, 95% level of confidence), and the uncertainty will not be taken into consideration for all the test data recorded in the report.

Test Equipment Setup

The spectrum analyzer or receiver is set as:

Below 1000MHz:

$$\text{RBW} = 100 \text{ kHz} / \text{VBW} = 300 \text{ kHz} / \text{Sweep} = \text{Auto}$$

Above 1000MHz:

$$\text{Peak: RBW} = 1\text{MHz} / \text{VBW} = 1\text{MHz} / \text{Sweep} = \text{Auto}$$

$$\text{Average: RBW} = 1\text{MHz} / \text{VBW} = 10\text{Hz} / \text{Sweep} = \text{Auto}$$

EUT Setup

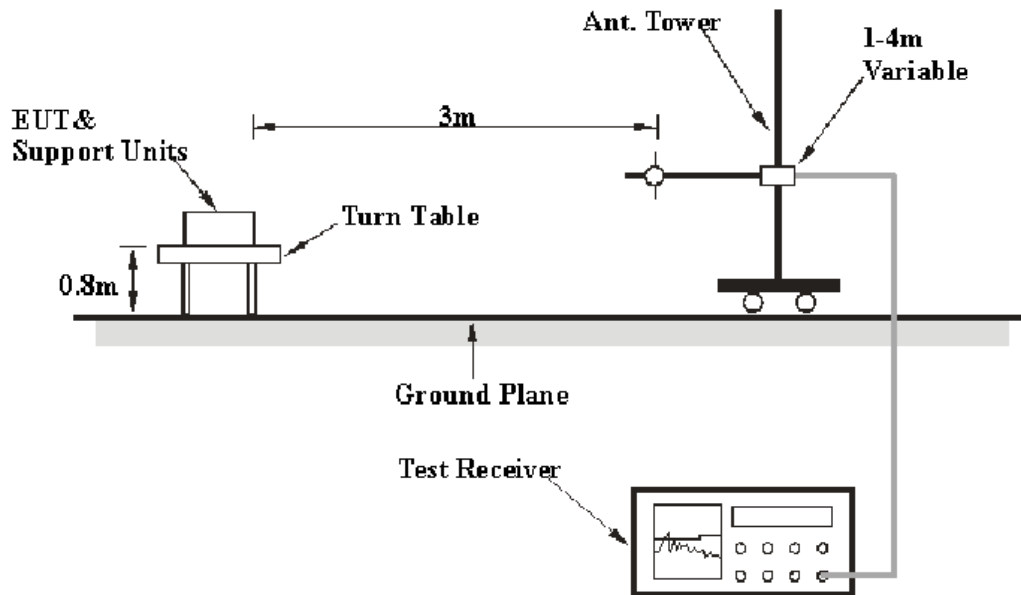

The radiated emission and out of band emission tests were performed in the 3 meters chamber test site, using the setup accordance with the ANSI C63.4-2009. The specification used was the FCC 15.209/15.205 and FCC 15.249 limits.

Test Procedure

Maximizing procedure was performed on the highest emissions to ensure that the EUT complied with all installation combinations.

The EUT is set 3 meter away from the testing antenna, which is varied from 1-4 mete, and the EUT is placed on a turntable, which is 0.8 meter above ground plane, the table shall be rotated for 360 degrees to find out the highest emission. The receiving antenna should be changed the polarization both of horizontal and vertical.

Corrected Amplitude & Margin Calculation

The Corrected Amplitude is calculated by adding the Antenna Factor and Cable Loss, and subtracting the Amplifier Gain from the Meter Reading. The basic equation is as follows:

$$\text{Corrected Amplitude} = \text{Meter Reading} + \text{Antenna Factor} + \text{Cable Loss} - \text{Amplifier Gain}$$

The “**Margin**” column of the following data tables indicates the degree of compliance with the applicable limit. For example, a margin of 7dB means the emission is 7dB below the limit. The equation for margin calculation is as follows:

$$\text{Margin} = \text{Limit} - \text{Corrected Amplitude}$$

Test Equipment List and Details

Manufacturer	Description	Model	Serial Number	Calibration Date	Calibration Due Date
HP	Amplifier	HP8447D	2944A09795	2011-11-24	2012-11-23
Rohde & Schwarz	EMI Test Receiver	ESCI	101122	2012-08-08	2012-08-07
Sunol Sciences	Broadband Antenna	JB1	A040904-1	2012-03-17	2013-03-16
Mini-Circuits	Amplifier	ZVA-213+	T-E27H	2012-03-08	2013-03-08
Sunol Sciences	Horn Antenna	DRH-118	A052304	2011-12-01	2012-11-30
Rohde & Schwarz	Signal Analyzer	FSIQ26	8386001028	2011-11-24	2012-11-23
the electro-Mechanics Co.	Horn Antenna	3116	9510-2270	2011-10-14	2012-10-13
R&S	Auto test Software	EMC32	V6.30	-	-

* **Statement of Traceability:** Bay Area Compliance Laboratories Corp. (Shenzhen) attests that all calibrations have been performed in accordance to NVLAP requirements, traceable to the NIST.

Test Results Summary

According to the data in the following table, the EUT complied with the FCC Part 15.209 & 15.205 & 15.249, with the worst margin reading of:

6.38 dB at 4860.0 MHz in the Vertical polarization

Test Data

Environmental Conditions

Temperature:	25 °C
Relative Humidity:	48 %
ATM Pressure:	100.0 kPa

The testing was performed by Mick Yin on 2012-09-26.

Test Mode: Transmitting

30MHz-25 GHz

Frequency (MHz)	Receiver		Turntable Degree	Rx Antenna		Corrected Factor (dB)	Corrected Amplitude (dBµV/m)	FCC Part 15.249/205/209	
	Reading (dBµV)	Detector (PK/QP/Ave.)		Height (m)	Polar (H/V)			Limit (dBµV/m)	Margin (dB)
Channel Frequency (2430 MHz)									
4860.0	55.16	PK	28	1.1	V	12.46	67.62	74	6.38
9720.0	47.19	PK	57	1.2	V	19.40	66.59	74	7.41
2430	76.74	Ave.	78	1.2	H	6.13	82.87	94	11.13
7290.0	44.72	PK	69	1.3	H	16.49	61.21	74	12.79
246.8	48.78	QP	226	1.5	H	-15.9	32.88	46	13.12
2430	74.12	Ave.	113	1.1	V	6.13	80.25	94	13.75
9720.0	19.74	Ave.	57	1.2	V	19.40	39.14	54	14.86
4860.0	24.61	Ave.	28	1.1	V	12.46	37.07	54	16.93
7290.0	20.17	Ave.	69	1.3	H	16.49	36.66	54	17.34
2430	89.19	PK	78	1.2	H	6.13	95.32	114	18.68
2430	87.90	PK	113	1.1	V	6.13	94.03	114	19.97
2386.6	45.27	PK	57	1.3	H	6.13	51.40	74	22.60
2493.8	43.67	PK	116	1.0	H	7.21	50.88	74	23.12
2386.6	22.26	Ave.	57	1.3	H	6.13	28.39	54	25.61
2493.8	21.03	Ave.	116	1.0	H	7.21	28.24	54	25.76
2492.5	21.08	Ave.	38	1.2	V	6.81	27.89	54	26.11
2492.5	40.41	PK	38	1.2	V	6.81	47.22	74	26.78

FCC§15.249(d) - OUT OF BAND EMISSION (50DB ATTENUATION)

Applicable Standard

Emissions radiated outside of the specified frequency bands, except for harmonics, shall be attenuated by at least 50 dB below the level of the fundamental or to the general radiated emission limits in §15.209, whichever is the lesser attenuation

Test Procedure

1. Check the calibration of the measuring instrument using either an internal calibrator or a known signal from an external generator.
2. Position the EUT without connection to measurement instrument. Turn on the EUT and connect its antenna terminal to measurement instrument via a low loss cable. Then set it to any one measured frequency within its operating range, and make sure the instrument is operated in its linear range.
3. Set RBW to 100 kHz and VBW of spectrum analyzer to 300 kHz with a convenient frequency span including 100 kHz bandwidth from band edge.
4. Measure the highest amplitude appearing on spectral display and set it as a reference level. Plot the graph with marking the highest point and edge frequency.
5. Repeat above procedures until all measured frequencies were complete.

Test Equipment List and Details

Manufacturer	Description	Model	Serial Number	Calibration Date	Calibration Due Date
Rohde & Schwarz	Signal Analyzer	FSIQ26	8386001028	2011-11-24	2012-11-23

* **Statement of Traceability:** Bay Area Compliance Laboratories Corp. (Shenzhen) attests that all calibrations have been performed in accordance to NVLAP requirements, traceable to the NIST.

Test Data

Environmental Conditions

Temperature:	25 °C
Relative Humidity:	48 %
ATM Pressure:	100.0 kPa

The testing was performed by Mick Yin on 2012-09-27.

Test Result: Compliance

Please refer to the following table and plots:

Frequency (MHz)	Delta Peak to Band Emission (dBc)	Delta Limit (dBc)	Result
2397.82	53.65	50	Pass
2489.26	56.17	50	Pass

Band Edge, Left Side

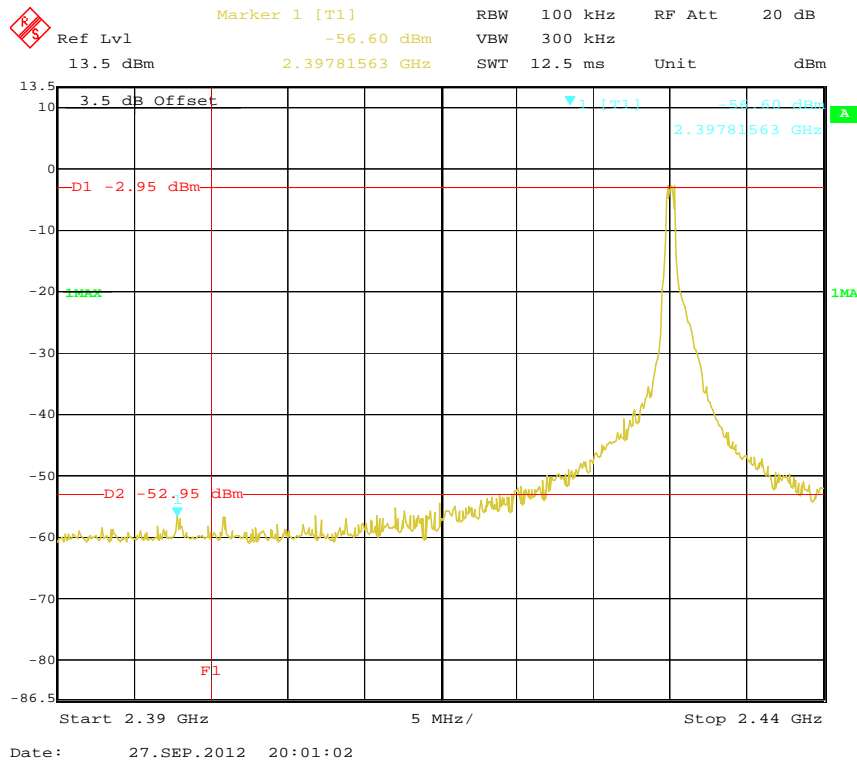

Band Edge, Right Side

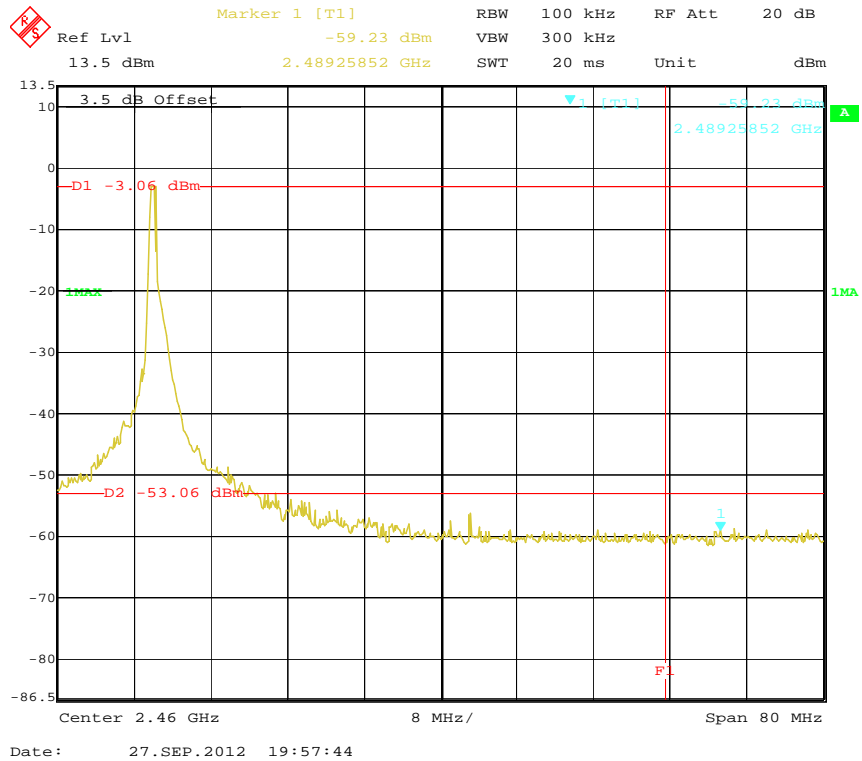

***** END OF REPORT *****