

FCC TEST REPORT

according to

FCC Rules and Regulations

Part 15 Subpart C

Applicant	SerComm Corporation
Address	8F, No. 3-1, YuanQu St., NanKang, Taipei 115, Taiwan, R.O.C.
Equipment	IEEE802.11g Wireless USB adapter
Model No.	UB801RE v2
Series No.	WNC-0305USB
FCC ID	P27UB801Re
Trade Name	SerComm

Laboratory Accreditation



1332

- The test result refers exclusively to the test presented test model / sample.,
- Without written approval of **Exclusive Certification Corp.** the test report shall not be reproduced except in full.
- The EUT is also considered as a kind of computer peripheral, because the connection to computer is necessary for typical use. It has been verified to comply with the requirements of FCC Part 15, Subpart B, Class B (DoC). The test report has been issued separately.

Contents

1. Report of Measurements and Examinations	5
1.1 List of Measurements and Examinations.....	5
2. Test Configuration of Equipment under Test	6
Feature of Equipment under Test.....	6
RF Specifications	6
2.1 Test Mode and Test Software.....	7
2.2 Description of Test System.....	7
2.3 Connection Diagram of Test System.....	8
2.4 General Information of Test.....	9
2.5 Description of Series model	9
2.6 History of this test report	9
3. Antenna Requirements	10
3.1 Standard Applicable	10
3.2 Antenna Construction and Directional Gain.....	10
4. Test of Conducted Emission	11
4.1 Test Limit.....	11
4.2 Test Procedures.....	11
4.3 Typical Test Setup	12
4.4 Measurement equipment	12
4.5 Test Result and Data.....	13
4.6 Test Photographs	15
5. Test of Radiated Emission	16
5.1 Test Limit.....	16
5.2 Test Procedures.....	17
5.3 Typical Test Setup.....	18
5.4 Measurement equipment	18
5.5 Test Result and Data.....	19
5.6 Test Photographs	35
6. 6dB Bandwidth Measurement Data	36
6.1 Test Limit	36
6.2 Test Procedures	36
6.3 Test Setup Layout	36
6.4 Measurement equipment	36
6.5 Test Result and Data.....	36
7. Maximum Peak Output Power	40
7.1 Test Limit	40
7.2 Test Procedures	40
7.3 Test Setup Layout	40
7.4 List of Measuring Equipment Used.....	40
7.5 Test Result and Data.....	40
8. Band Edges Measurement	44
8.1 Test Limit	44
8.2 Test Procedure :	44
8.3 Test Setup Layout	44
8.4 List of Measuring Equipment Used.....	44
8.5 Test Result and Data.....	44

8.6 Restrict band emission Measurement Data49

9. Power Spectral Density50

9.1 Test Limit50

9.2 Test Procedures50

9.3 Test Setup Layout :50

9.4 List of Measuring Equipment Used50

9.5 Test Result and Data50

10. Restricted Bands of Operation54

10.1 Labeling Requirement54

Appendix A. Photographs of EUT.....A1 ~ A4

CERTIFICATE OF COMPLIANCE

according to

FCC Rules and Regulations

Part 15 Subpart C

Applicant	SerComm Corporation
Address	8F, No. 3-1, YuanQu St., NanKang, Taipei 115, Taiwan, R.O.C.
Equipment	802.11g Wireless USB Adapter
Model No.	UB801Re v2
Series No.	WNC-0305USB
FCC ID	P27UB801Re

I HEREBY CERTIFY THAT :

The measurements shown in this test report were made in accordance with the procedures given in **ANSI C63.4** The equipment was **passed** the test performed according to **FCC Rules and Regulations Part 15 Subpart C (2003)**.

The test was carried out on Feb. 08, 2006 at **Exclusive Certification Corp.**

Signature



Eric Chan / Manager

1. Report of Measurements and Examinations

1.1 List of Measurements and Examinations

FCC Rule	Description of Test	Result
15.203	. Antenna Requirement	Pass
15.207	. Conducted Emission	Pass
15.209	. Radiated Emission	Pass
15.247(a)(2)	. 6dB Bandwidth	Pass
15.247(b)	. Maximum Peak Output Power	Pass
15.247(c)	. 100kHz Bandwidth of Frequency Band Edges	Pass
15.247(d)	. Power Spectral Density	Pass
1.1307 1.1310 2.1091 2.1093	. RF Exposure Compliance	Pass

Test engineer: _____

Jerry

2. Test Configuration of Equipment under Test

Feature of Equipment under Test

- Reliable IEEE 802.11g and b standards-based wireless technology
- 54 Mbps high speed data transfer. Wireless nodes negotiate to operate in the optimal data transfer rate. In a noisy environment or when the distance between the wireless nodes is far, the wireless nodes automatically fall back to operate at lower transfer rates.
- High level of data encryption using 128-bit Shared Key WEP data encryption method. A lower level of data encryption or no data encryption is available to simplify your network setup or to improve data transfer rate.
- WPA PSK (Wi-Fi Protected Access Pre-Shared Key) support.

RF Specifications

Chipset:	RF Chip:
RF Chip:	Realtek RTL8225
Bus Type:	USB 2.0
Data Rates :	54, 48, 36, 24, 18, 12, 9, and 6 Mbps(802.11g)
	11, 5.5, 2, 1 Mbps (802.11b)
Frequency Band :	2.4GHz to 2.462GHz
Wireless Medium :	DSSS and OFDM
Media Access Protocol:	CSMA/CA
Operating Channels:	1-14(FCC:1-11、 ETSI:1-13、 Japan:1-14)
Operating Range:	<ul style="list-style-type: none"> • Indoors: Up to 328 ft (100 meters) • Outdoors: Up to 1312 ft (400 meters)
Receive Sensitivity :	
802.11g	54 Mbps: -71 dBm 48 Mbps: -73 dBm 36 Mbps: -77 dBm 24 Mbps: -81 dBm 18 Mbps: -83 dBm 12 Mbps: -83 dBm 9 Mbps: -83 dBm 6 Mbps: -83 dBm
802.11b	11 Mbps: -84 dBm 5.5 Mbps: -85 dBm 2 Mbps: -86 dBm 1 Mbps: -86 dBm
Wireless Medium:	DSSS (Direct Sequence Spread Spectrum)
Media Access Protocol:	CSMA/CA
Transmit Power:	
802.11g:	14±1 dBm
802.11b:	18±1 dBm
Security :	64/128-bit WEP WPA—Wi-Fi Protected Access
Standards	WPA certified, IEEE 802.11g, IEEE 802.11b
EMI:	FCC, CE
Environmental Range:	
Operating temperature:	0o to 40°C (32o to 104°F)
Operating humidity:	0 to 90% non-condensing
System Requirements	Notebook or desktop PC with USB port; USB 2.0 required for 54 Mbps data rate Notebook or desktop PC must be running Windows 98SE/ME/XP/ 2000

2.1 Test Mode and Test Software

The following test mode and test software was performed for conduction and radiation test:

- 802.11b (CH LO: 2412MHz) • 802.11b (CH MID: 2437MHz) • 802.11b (CH HI: 2462MHz)
- 802.11g (CH LO: 2412MHz) • 802.11g (CH MID: 2437MHz) • 802.11g (CH HI: 2462MHz)

An executive programs, "MP8187VC.EXE" Application under WIN XP.

2.2 Description of Test System

Device	Manufacturer	Model No.	Description
PC	IBM	IGV	Power Cable, Unshielding 1.8 m
Monitor	SlimAGE	510A	Power Cable, Adapter Unshielding 1.8 m Data Cable, VGA shielding 1.35 m
Keyboard	IBM	KB-0225	Data Cable, PS2 shielding 1.85 m
Mouse	IBM	MO28VO	Data Cable, USB shielding 1.85 m
Modem	ACEXX	DM-1414	Power Cable, Adapter Unshielding 1.8 m Data Cable, Unshielding 1.35 m
Printer	HP	Desk Jet400	Power Cable, Adapter Unshielding 1.8 m Data Cable, Shielding 1.6 m

2.3 Connection Diagram of Test System

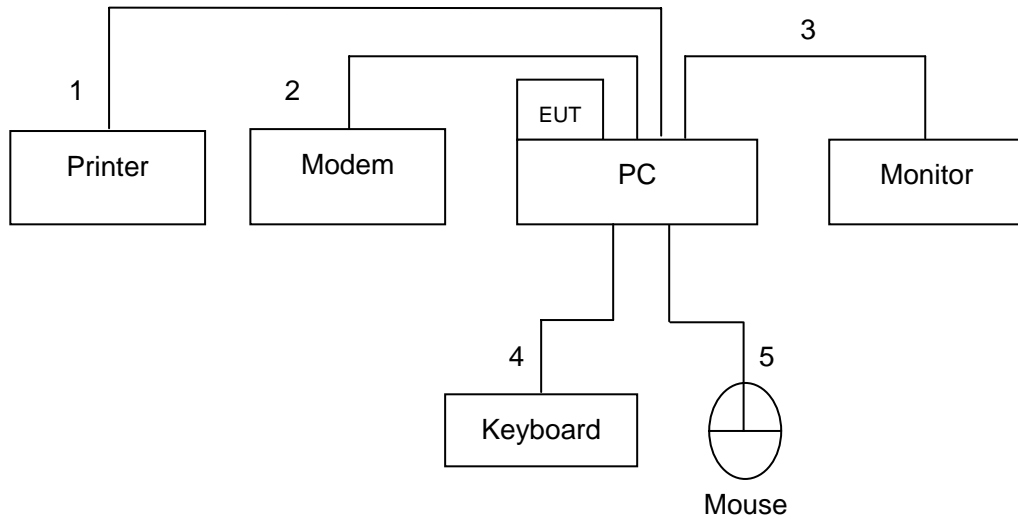

1. The I/O cable is connected from PC to the Printer
2. The I/O cable is connected from PC to the Modem
3. The I/O cable is connected from PC to the Monitor
4. The I/O cable is connected from PC to the Keyboard
5. The I/O cable is connected from PC to the Mouse

2.4 General Information of Test

Test Site:	Exclusive Certification Corp. 4F-2, No. 28, Lane 78, Xing-Ai Rd. Nei-hu, Taipei City 114 Taiwan R.O.C.
Test Site Location (OATS1-SD):	No.68-1, Shihbachongsi, shihding Township, Taipei City 223, Taiwan, R.O.C.
FCC Registration Number	632249
Test Voltage:	DC 5V
Test in Compliance with:	ANSI C63.4-2003 FCC Part 15 Subpart C
Frequency Range Investigated:	Conducted: from 150kHz to 30 MHz Radiation: from 30 MHz to 24620MHz
Test Distance:	The test distance of radiated emission from antenna to EUT is 3 M.

2.5 Description of Series model

The Series Model: WNC-0305USB and the Model No.:UB801RE v2 are the same, and they only differ from the model No. and trade name. The function and specifications are the same.

2.6 History of this test report

The Model No.: WG111 V2 (Report No: FI06012401-A) and Model No. :UB801RE v2 (Report No: FI06012401-E) are the same, and they only differ from the model No., trade name and outside cosmetic. The function and specifications are the same.

3. Antenna Requirements

3.1 Standard Applicable

For intentional device, according to FCC 47 CFR Section 15.203, an intentional radiator shall be designed to ensure that no antenna other than that furnished by the responsible party shall be used with the device.

And according to FCC 47 CFR Section 15.247 (b), if transmitting antennas of directional gain greater than 6dBi are used, the power shall be reduced by the amount in dB that the directional gain of the antenna exceeds 6dBi.

3.2 Antenna Construction and Directional Gain

Antenna type: Printed Antenna

Antenna Gain: 0dBi.

4. Test of Conducted Emission

4.1 Test Limit

Conducted Emissions were measured from 150 kHz to 30 MHz with a bandwidth of 9 KHz on the 120 VAC power and return leads of the EUT according to the methods defined in ANSI C63.4-2003 Section 3.1. The EUT was placed on a nonmetallic stand in a shielded room 0.8 meters above the ground plane as shown in section 2.2. The interface cables and equipment positioning were varied within limits of reasonable applications to determine the position produced maximum conducted emissions.

Frequency (MHz)	Quasi Peak (dB μ V)	Average (dB μ V)
0.15 – 0.5	66-56*	56-46*
0.5 – 5.0	56	46
5.0 – 30.0	60	50

*Decreases with the logarithm of the frequency.

4.2 Test Procedures

- a. The EUT was placed 0.4 meter from the conducting wall of the shielding room was kept at least 80 centimeters from any other grounded conducting surface.
- b. Connect EUT to the power mains through a line impedance stabilization network (LISN).
- c. All the support units are connecting to the other LISN.
- d. The LISN provides 50 ohm coupling impedance for the measuring instrument.
- e. The FCC states that a 50 ohm, 50 micro-Henry LISN should be used.
- f. Both sides of AC line were checked for maximum conducted interference.
- g. The frequency range from 150 kHz to 30 MHz was searched.
- h. Set the test-receiver system to Peak Detect Function and Specified Bandwidth with Maximum Hold Mode.

4.3 Typical Test Setup

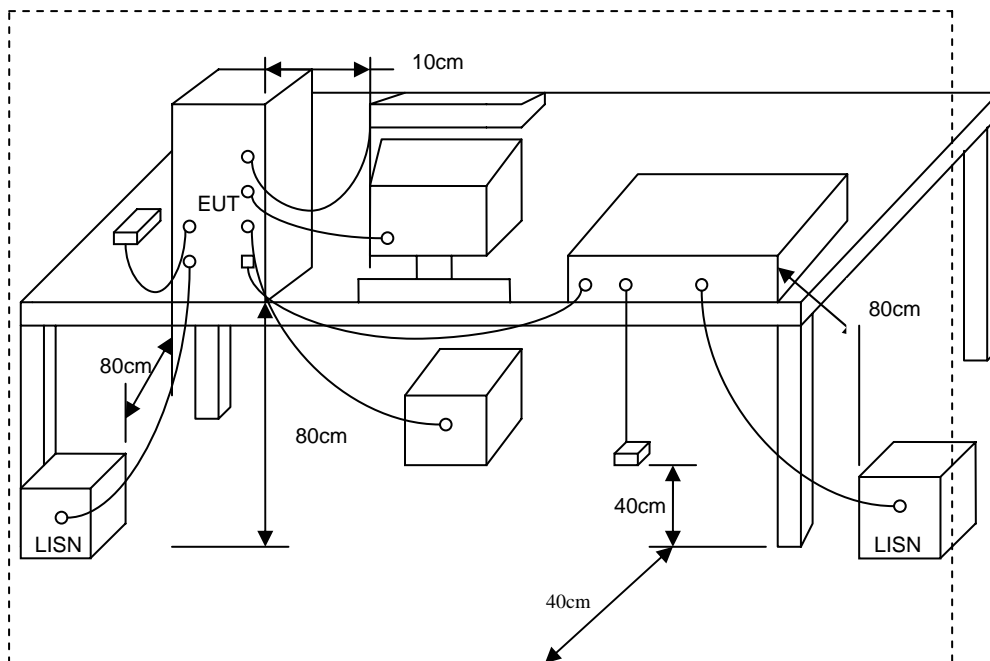

4.4 Measurement equipment

Instrument/Ancillary	Model No.	Manufacturer	Serial No.	Valid Date.
Receiver	SCR3501	Schaffner	437	2006/11/03
LISN	NNB-2/16Z	MESS TEC	02/10191	2006/03/30
LISN	NNB-2/16Z	ROLF HEINE	03/10058	2006/05/01

4.5 Test Result and Data

EUT : WG111V2
 Power : DC 5V from PC
 Test Mode : 802.11g CH 1
 Memo :

Pol/Phase : NEUTRAL
 Temperature : 24 °C
 Humidity : 66 %

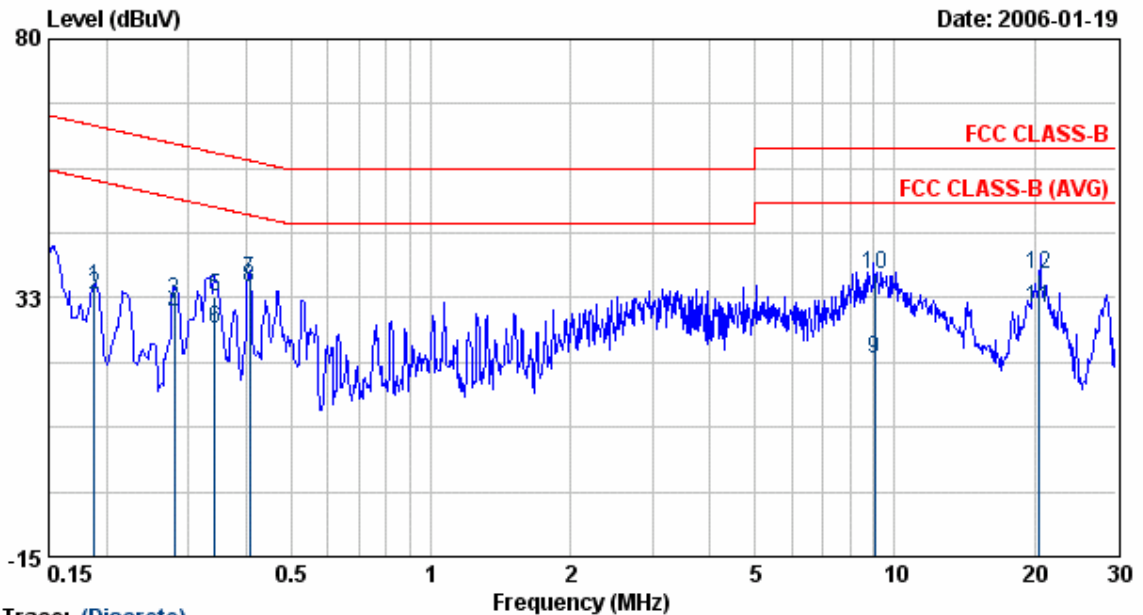

Trace: (Discrete)

Freq	Read Level	Factor	Level	Limit	Over Limit	Remark
MHz	dBuV	dB	dBuV	dBuV	dBuV	
0.19	34.20	0.23	34.43	64.11	-29.68	QP
0.19	32.95	0.23	33.18	54.11	-20.93	AVERAGE
0.28	31.70	0.35	32.05	60.81	-28.76	QP
0.28	28.92	0.35	29.27	50.81	-21.54	AVERAGE
0.34	32.10	0.43	32.53	59.14	-26.60	QP
0.34	26.33	0.43	26.76	49.14	-22.37	AVERAGE
0.41	35.39	0.50	35.89	57.73	-21.84	QP
0.41	33.89	0.50	34.39	47.73	-13.34	AVERAGE
9.07	20.81	0.60	21.41	50.00	-28.59	AVERAGE
9.07	36.33	0.60	36.93	60.00	-23.07	QP
20.51	29.95	0.80	30.75	50.00	-19.25	AVERAGE
20.51	35.90	0.80	36.70	60.00	-23.30	QP

- Remarks:
1. Level = Read Level + Factor
 2. Factor = LISN(ISN) Factor + Cable Loss
 3. All emission below 1GHz at 802.11b/g mode are all the same,so the 802.11g mode chosen as representative in final test.
 4. According to technical experiences,all spurious emission of 802.11g channel 1 was chosen as representative in final test.
 5. The data is worse case.

EUT : WG111V2
 Power : DC 5V from PC
 Test Mode : 802.11g CH 1
 Memo :

Pol/Phase : LINE
 Temperature : 24 °C
 Humidity : 66 %

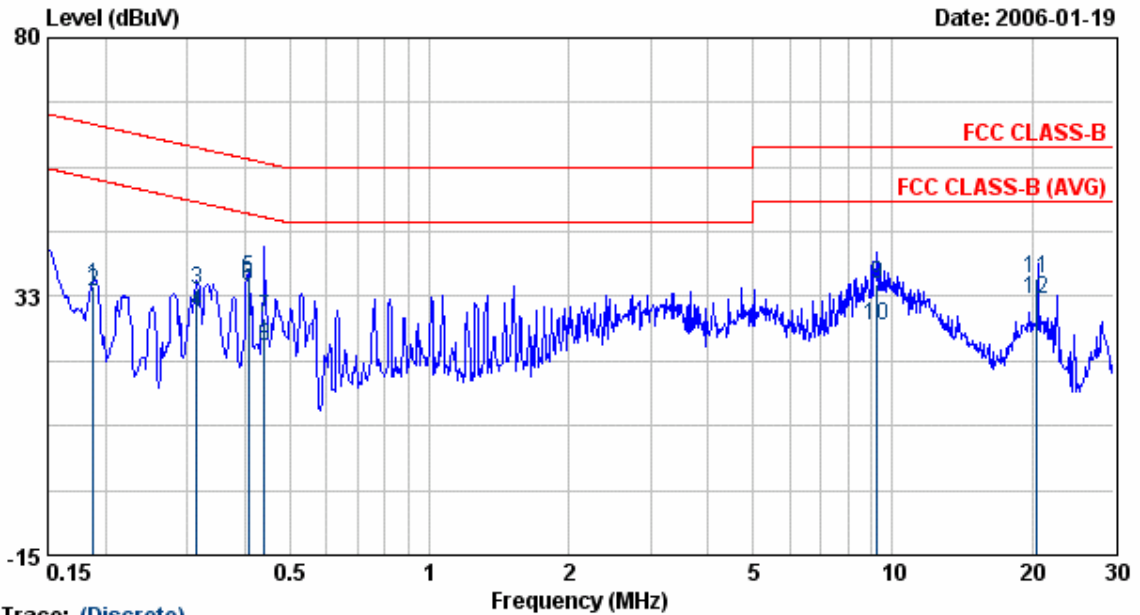

Trace: (Discrete)

Freq	Read Level	Factor	Level	Limit	Over Limit	Remark
MHz	dBuV	dB	dBuV	dBuV	dBuV	
0.19	34.10	0.32	34.42	64.11	-29.69	QP
0.19	33.14	0.32	33.46	54.11	-20.65	AVERAGE
0.31	33.29	0.50	33.79	59.84	-26.05	QP
0.31	29.00	0.50	29.50	49.84	-20.34	AVERAGE
0.41	35.03	0.60	35.63	57.73	-22.10	QP
0.41	33.78	0.60	34.38	47.73	-13.35	AVERAGE
0.44	27.98	0.59	28.57	57.07	-28.50	QP
0.44	22.87	0.59	23.46	47.07	-23.61	AVERAGE
9.28	34.13	0.61	34.74	60.00	-25.26	QP
9.28	26.68	0.61	27.29	50.00	-22.71	AVERAGE
20.51	35.27	0.62	35.89	60.00	-24.11	QP
20.51	31.53	0.62	32.15	50.00	-17.85	AVERAGE

- Remarks:
1. Level = Read Level + Factor
 2. Factor = LISN(ISN) Factor + Cable Loss
 3. All emission below 1GHz at 802.11b/g mode are all the same,so the 802.11g mode chosen as representative in final test.
 4. According to technical experiences,all spurious emission of 802.11g channel 1 was chosen as representative in final test.
 5. The data is worse case.

Test engineer: Jerry

5. Test of Radiated Emission

5.1 Test Limit

Radiated emissions from 30 MHz to 25 GHz were measured according to the methods defines in ANSI C63.4-2003. The EUT was placed, 0.8 meter above the ground plane, as shown in section 5.6.3. The interface cables and equipment positions were varied within limits of reasonable applications to determine the positions producing maximum radiated emissions. For unintentional device, according to § 15.109(a), except for Class A digital devices, the field strength of radiated emissions from unintentional radiators at a distance of 3 meters shall not exceed the following values:

Frequency (MHz)	Distance Meters	Radiated (μ V / M)	Radiated (dB μ V/ M)
30-88	3	100	40.0
88-216	3	150	43.5
216-960	3	200	46.0
Above 960	3	500	54.0

For unintentional device, according to CISPR PUB.22, for Class B digital devices, the general requirement of field strength of radiated emissions from intentional radiators at a distance of 10 meters shall not exceed the above table.

Frequency (MHz)	Distance Meters	Radiated (dB μ V/ M)
30-230	10	30
230-1000	10	37

5.2 Test Procedures

1. The EUT was placed on a rotatable table top 0.8 meter above ground.
2. The EUT was set 3 meters from the interference receiving antenna which was mounted on the top of a variable height antenna tower.
3. The table was rotated 360 degrees to determine the position of the highest radiation.
4. The antenna is a broadband antenna and its height is varied between one meter and four meters above ground to find the maximum value of the field strength both horizontal polarization and vertical polarization of the antenna are set to make the measurement.
5. For each suspected emission the EUT was arranged to its worst case and then tune the antenna tower (from 1 M to 4 M) and turn table (from 0 degree to 360 degrees) to find the maximum reading.
6. Set the test-receiver system to Peak or CISPR quasi-peak Detect Function and specified bandwidth with Maximum Hold Mode.
7. If the emission level of the EUT in peak mode was 3 dB lower than the limit specified, then testing will be stopped and peak values of EUT will be reported, otherwise, the emissions which do not have 3 dB margin will be repeated one by one using the quasi-peak method and reported.
8. For testing above 1GHz, the emission level of the EUT in peak mode was 20dB lower than average limit (that means the emission level in peak mode also complies with the limit in average mode), then testing will be stopped and peak values of EUT will be reported, otherwise, the emissions will be measured in average mode again and reported.

5.3 Typical Test Setup

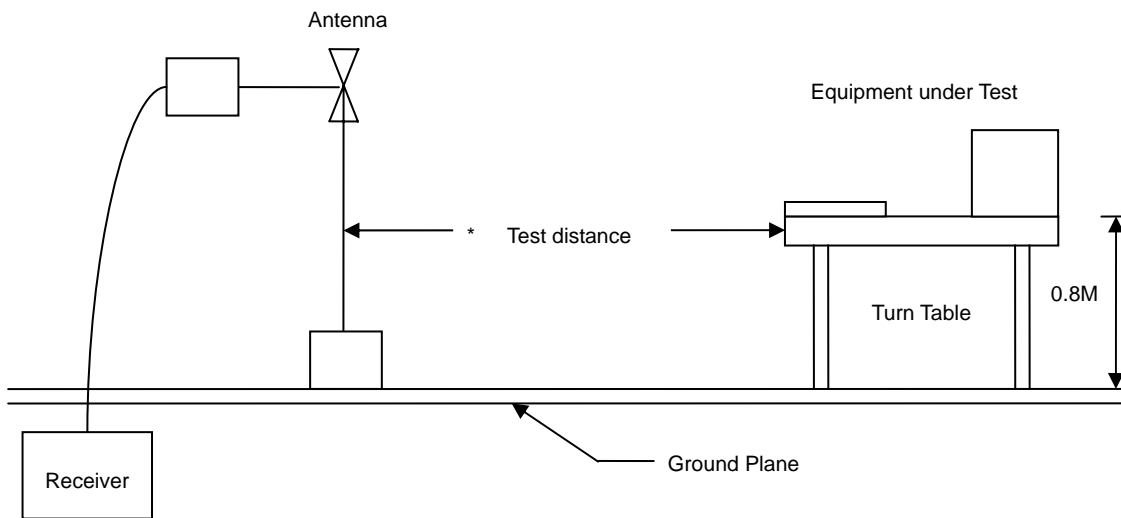

5.4 Measurement equipment

Instrument/Ancillary	Model No.	Manufacturer	Serial No.	Valid Date
EMI Receiver	8546A	HP	3807A00454	2006/04/13
Spectrum Analyzer	FSP40	R&S	10047	2007/01/16
Horn Antenna	3115	EMCO	31589	2007/02/12
Horn Antenna	3116	EMCO	31970	2007/02/09
Bilog Antenna	CBL6112B	Schaffner	2840	2006/04/11
Amplifier	8449B	Agilent	3008A01954	2007/01/08
Amplifier	8447D	Agilent	2944A10531	2006/08/09

5.5 Test Result and Data

```

EUT           : WG111V2
Power         : DC 5V from PC
Test Mode     : Transmit/Receive
Operation Channel: 1
Modulation Type : 802.11g
Rate          : 54 Mbps
Memo         :

Pol/Phase     : HORIZONTAL
Temperature   : 14 °C
Humidity      : 70 %
Atmospheric Pressure: 1032 mmHg
    
```

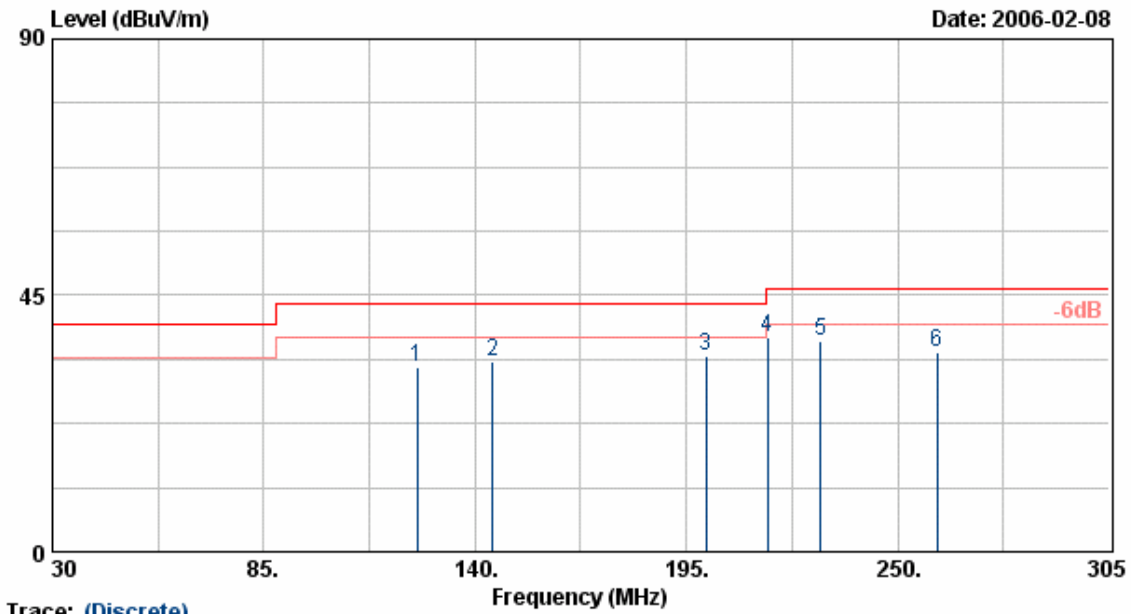

Frequency (MHz)	Meter Reading (dBuV)	Corrected Factor (dBuV/m)	Result (dBuV/m)	Limit (dB)	Margin (dB)	Remark	Table Deg.	Ant High (cm)
125.01	48.37	-15.87	32.51	43.50	-10.99	Peak	0	400
144.68	49.17	-15.71	33.46	43.50	-10.04	Peak	74	400
200.20	51.86	-17.53	34.33	43.50	-9.17	Peak	42	400
216.18	55.01	-17.53	37.47	46.00	-8.53	Peak	311	400
229.93	53.82	-16.82	37.01	46.00	-8.99	Peak	0	400
260.18	47.67	-12.78	34.90	46.00	-11.10	Peak	344	400

- Notes:
1. Result = Meter Reading + Corrected Factor
 2. Corrected Factor = Antenna Factor + Cable Loss - Amplifier
 3. The resolution bandwidth of test receiver/spectrum analyzer is 120KHz and video bandwidth is 300kHz for Peak detection and Quasi-peak detection at frequency below 1GHz.
 4. All emission below 1GHz at 802.11b/g mode are all the same,so the 802.11g mode chosen as representative in final test.
 5. According to technical experiences,all spurious emission of 802.11g mode at channel 1,6,11 are almost the same below 1GHz,so that the channel 1 was chosen as representative in final test.
 6. The data is worse case.

EUT : WG111V2
 Power : DC 5V from PC
 Test Mode : Transmit/Receive
 Operation Channel : 1
 Modulation Type : 802.11g
 Rate : 54 Mbps
 Memo :
 Pol/Phase : HORIZONTAL
 Temperature : 14 °C
 Humidity : 70 %
 Atmospheric Pressure : 1032 mmHg

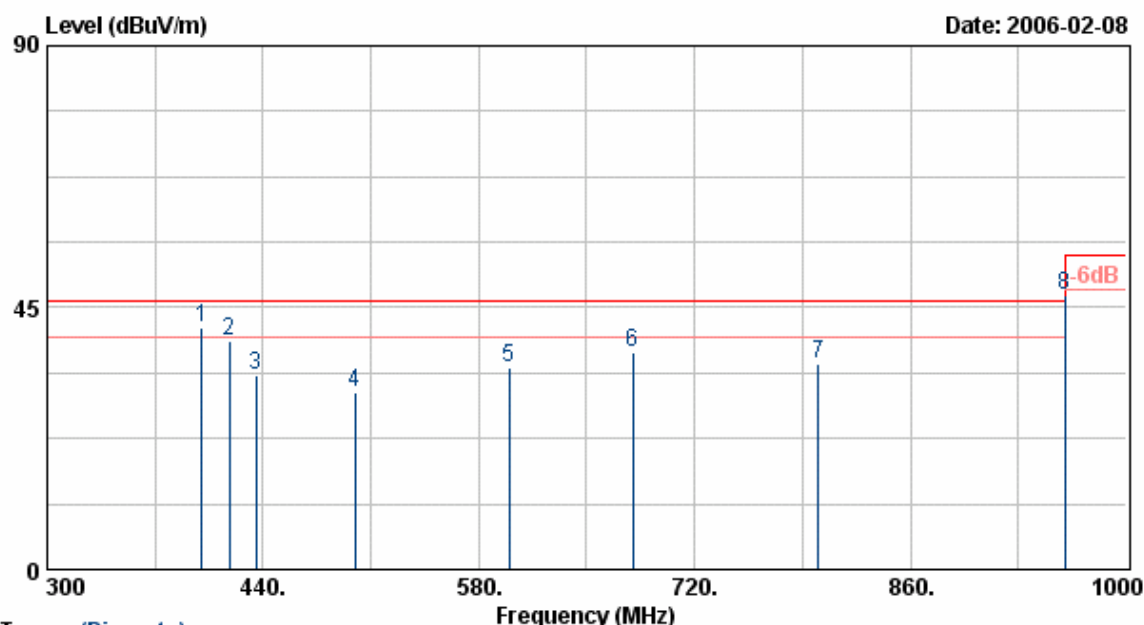

Trace: (Discrete)

Frequency (MHz)	Meter Reading (dBUV)	Corrected Factor (dBUV/m)	Result (dBUV/m)	Limit (dB)	Margin (dB)	Remark	Table Deg.	Ant High (cm)
400.00	51.11	-9.69	41.42	46.00	-4.58	QP	55	100
418.30	48.59	-9.28	39.31	46.00	-6.69	Peak	0	100
435.80	42.52	-9.07	33.45	46.00	-12.55	Peak	96	100
499.90	37.96	-7.50	30.46	46.00	-15.54	Peak	215	100
599.90	39.74	-5.04	34.69	46.00	-11.31	Peak	304	100
679.90	41.37	-4.18	37.19	46.00	-8.81	Peak	177	100
800.10	37.40	-2.03	35.37	46.00	-10.63	Peak	0	100
960.01	44.93	2.06	46.99	54.00	-7.01	Peak	360	100

Notes:

1. Result = Meter Reading + Corrected Factor
2. Corrected Factor = Antenna Factor + Cable Loss - Amplifier
3. The resolution bandwidth of test receiver/spectrum analyzer is 120KHz and video bandwidth is 300kHz for Peak detection and Quasi-peak detection at frequency below 1GHz.
4. All emission below 1GHz at 802.11g mode are all the same,so the 802.11g mode chosen as representative in final test.
5. According to technical experiences,all spurious emission of 802.11g mode at channel 1,6,11 are almost the same below 1GHz,so that the channel 1 was chosen as representative in final test.
6. The data is worse case.

```

EUT           : WG111V2
Power         : DC 5V from PC
Test Mode     : Transmit/Receive
Operation Channel: 1
Modulation Type : 802.11g
Rate          : 54 Mbps
Memo         :

Pol/Phase     : VERTICAL
Temperature   : 14 °C
Humidity      : 70 %
Atmospheric Pressure: 1032 mmHg
    
```

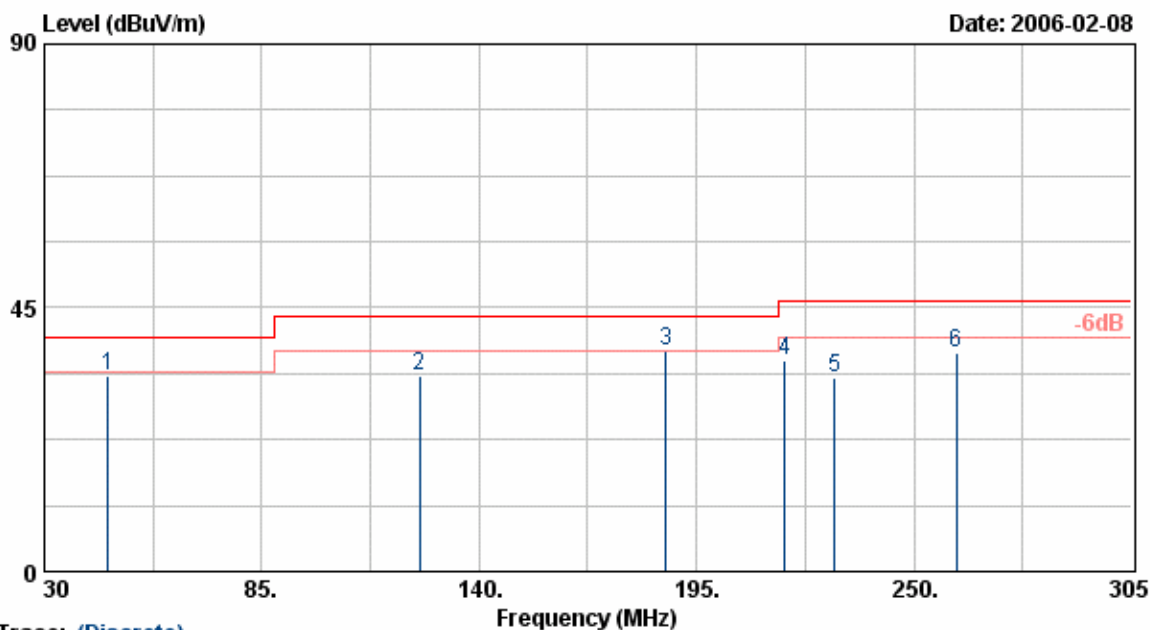

Trace: (Discrete)

Frequency (MHz)	Meter Reading (dBuV)	Corrected Factor (dBuV/m)	Result (dBuV/m)	Limit (dB)	Margin (dB)	Remark	Table Deg.	Ant High (cm)
46.23	51.40	-18.02	33.38	40.00	-6.62	Peak	360	300
125.03	49.17	-15.87	33.31	43.50	-10.19	Peak	47	300
187.25	55.18	-17.63	37.56	43.50	-5.94	QP	66	300
217.25	53.69	-17.55	36.13	46.00	-9.87	Peak	360	300
229.93	49.72	-16.82	32.91	46.00	-13.09	Peak	22	300
260.73	49.99	-12.75	37.24	46.00	-8.76	Peak	360	300

Notes:

1. Result = Meter Reading + Corrected Factor
2. Corrected Factor = Antenna Factor + Cable Loss - Amplifier
3. The resolution bandwidth of test receiver/spectrum analyzer is 120KHz and video bandwidth is 300kHz for Peak detection and Quasi-peak detection at frequency below 1GHz.
4. All emission below 1GHz at 802.11g mode are all the same, so the 802.11g mode chosen as representative in final test.
5. According to technical experiences, all spurious emission of 802.11g mode at channel 1,6,11 are almost the same below 1GHz, so that the channel 1 was chosen as representative in final test.
6. The data is worse case.

```

EUT           : WG111V2
Power         : DC 5V from PC
Test Mode    : Transmit/Receive
Operation Channel: 1
Modulation Type : 802.11g
Rate         : 54 Mbps
Memo         :

Pol/Phase    : VERTICAL
Temperature  : 14 °C
Humidity     : 70 %
Atmospheric Pressure: 1032 mmHg
    
```

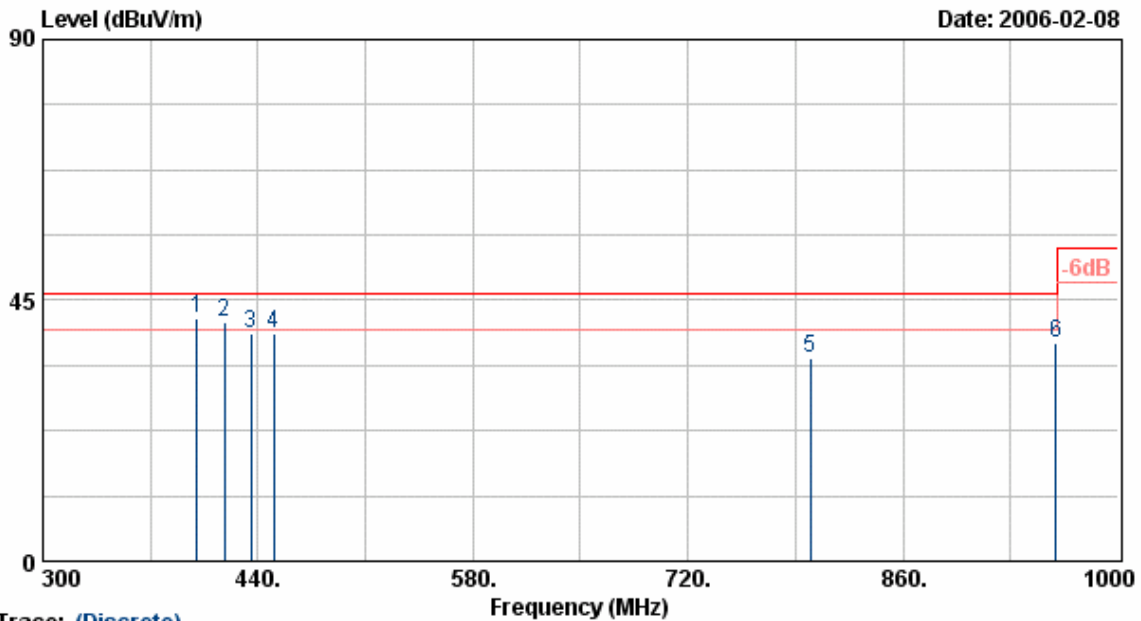

Trace: (Discrete)

Frequency (MHz)	Meter Reading (dBuV)	Corrected Factor (dBuV/m)	Result (dBuV/m)	Limit (dB)	Margin (dB)	Remark	Table Deg.	Ant High (cm)
400.30	51.63	-9.68	41.95	46.00	-4.05	QP	86	100
418.30	50.55	-9.28	41.27	46.00	-4.73	QP	223	100
435.80	48.34	-9.07	39.27	46.00	-6.73	Peak	0	100
450.30	48.17	-8.84	39.34	46.00	-6.66	Peak	33	100
800.00	37.20	-2.04	35.16	46.00	-10.84	Peak	0	100
959.66	35.67	2.09	37.75	46.00	-8.25	Peak	314	100

Notes:

1. Result = Meter Reading + Corrected Factor
2. Corrected Factor = Antenna Factor + Cable Loss - Amplifier
3. The resolution bandwidth of test receiver/spectrum analyzer is 120KHz and video bandwidth is 300kHz for Peak detection and Quasi-peak detection at frequency below 1GHz.
4. All emission below 1GHz at 802.11b/g mode are all the same, so the 802.11g mode chosen as representative in final test.
5. According to technical experiences, all spurious emission of 802.11g mode at channel 1,6,11 are almost the same below 1GHz, so that the channel 1 was chosen as representative in final test.
6. The data is worse case.

EUT : WG111V2
 Power : DC 5V from PC
 Test Mode : Transmit/Receive
 Operation Channel: 1
 Modulation Type : 802.11b
 Rate : 11 Mbps
 Memo :
 Pol/Phase : HORIZONTAL
 Temperature : 14 °C
 Humidity : 70 %
 Atmospheric Pressure: 1032 mmHg

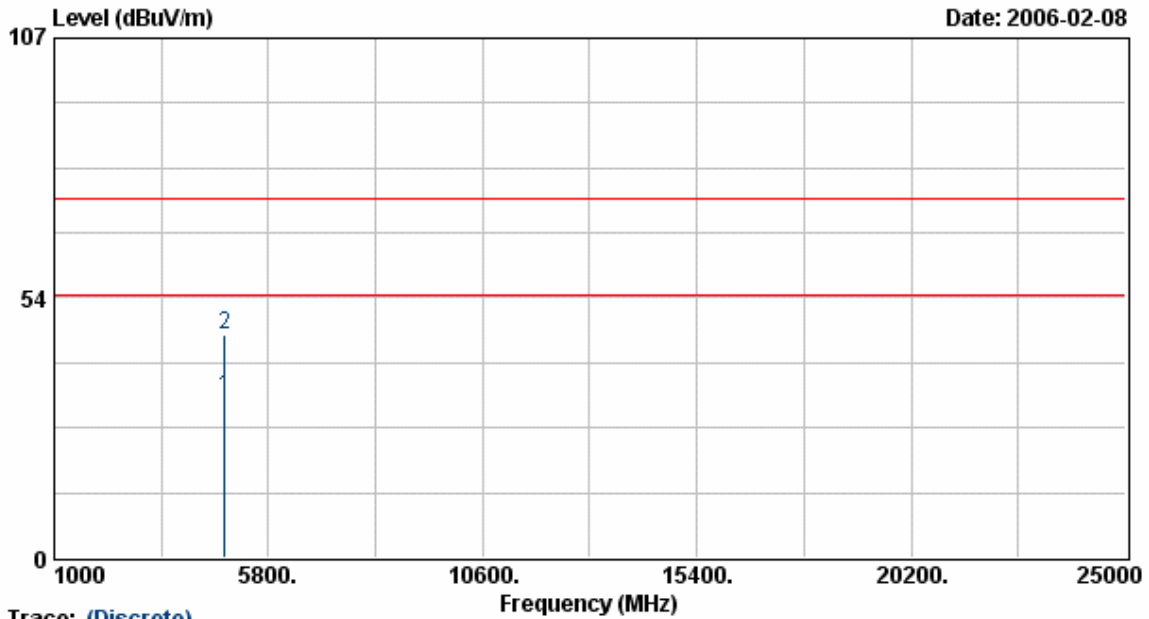

Trace: (Discrete)

Frequency (MHz)	Meter Reading (dBuV)	Corrected Factor (dBuV/m)	Result (dBuV/m)	Limit (dB)	Margin (dB)	Remark	Table Deg.	Ant High (cm)
4821.98	28.34	4.85	33.19	54.00	-20.81	Average	34	100
4821.98	40.90	4.85	45.75	74.00	-28.25	Peak	34	100

Notes:

1. Result = Meter Reading + Corrected Factor
2. Corrected Factor = Antenna Factor + Cable Loss - Amplifier
3. The resolution bandwidth of test receiver/spectrum analyzer is 120KHz and video bandwidth is 300kHz for Peak detection and Quasi-peak detection at frequency below 1GHz.
4. The resolution bandwidth of test receiver/spectrum analyzer is 1MHz and video bandwidth is 3MHz for Peak detection at frequency above 1GHz.
5. The resolution bandwidth of test receiver/spectrum analyzer is 1MHz and video bandwidth is 10Hz for Average detection at frequency above 1GHz.
6. The other emissions is too low to be measured.

```

EUT           : WG111V2
Power         : DC 5V from PC
Test Mode     : Transmit/Receive
Operation Channel: 1
Modulation Type : 802.11b
Rate         : 11 Mbps
Memo         :

Pol/Phase     : VERTICAL
Temperature   : 14 °C
Humidity      : 70 %
Atmospheric Pressure: 1032 mmHg
    
```

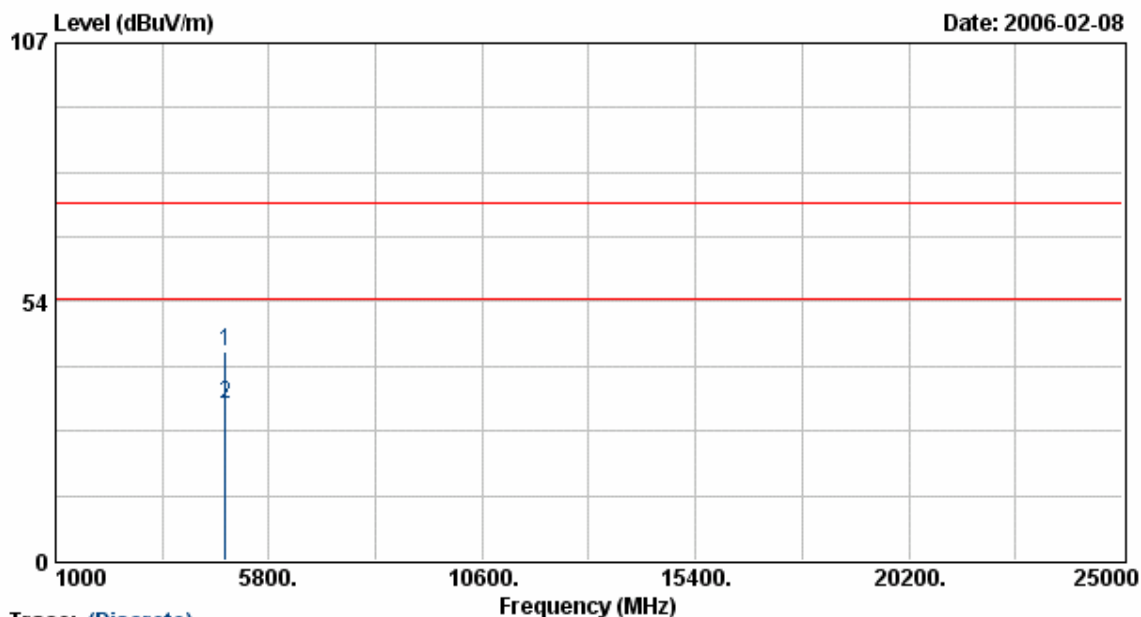

Trace: (Discrete)

Frequency (MHz)	Meter Reading (dBuV)	Corrected Factor (dBuV/m)	Result (dBuV/m)	Limit (dB)	Margin (dB)	Remark	Table Deg.	Ant High (cm)
4823.41	38.50	4.86	43.35	74.00	-30.65	Peak	294	100
4823.41	27.42	4.86	32.28	54.00	-21.72	Average	294	100

Notes:

1. Result = Meter Reading + Corrected Factor
2. Corrected Factor = Antenna Factor + Cable Loss - Amplifier
3. The resolution bandwidth of test receiver/spectrum analyzer is 120KHz and video bandwidth is 300kHz for Peak detection and Quasi-peak detection at frequency below 1GHz.
4. The resolution bandwidth of test receiver/spectrum analyzer is 1MHz and video bandwidth is 3MHz for Peak detection at frequency above 1GHz.
5. The resolution bandwidth of test receiver/spectrum analyzer is 1MHz and video bandwidth is 10Hz for Average detection at frequency above 1GHz.
6. The other emissions is too low to be measured.

```

EUT           : WG111V2
Power         : DC 5V from PC
Test Mode     : Transmit/Receive
Operation Channel: 6
Modulation Type : 802.11b
Rate         : 11 Mbps
Memo         :

Pol/Phase     : HORIZONTAL
Temperature   : 14 °C
Humidity      : 70 %
Atmospheric Pressure: 1032 mmHg
    
```

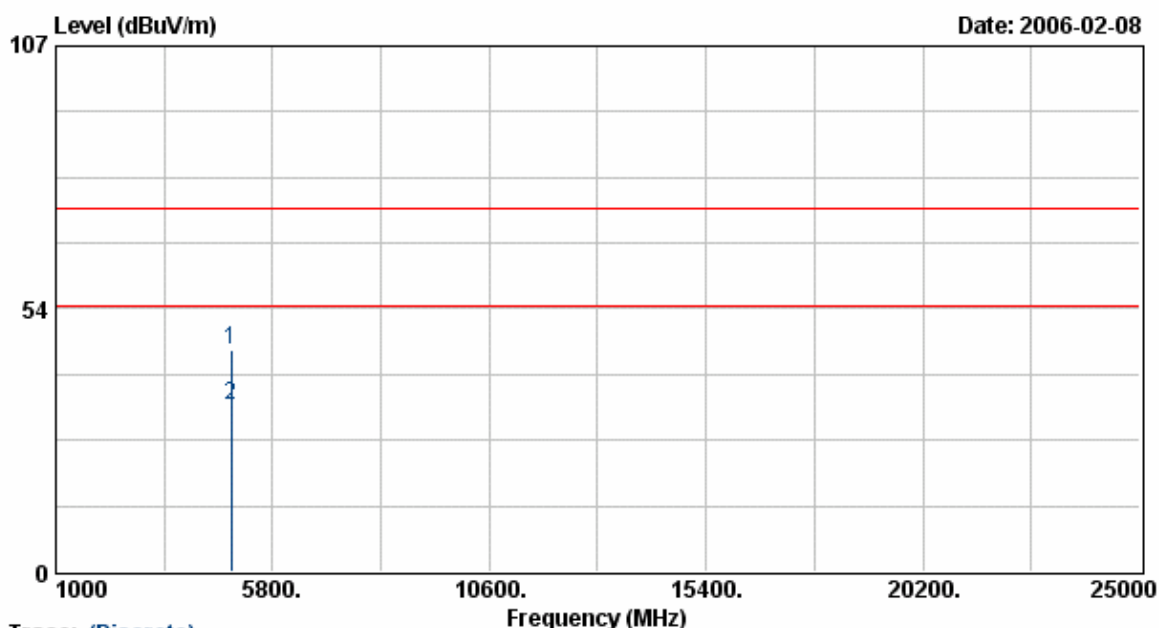

Frequency (MHz)	Meter Reading (dBuV)	Corrected Factor (dBuV/m)	Result (dBuV/m)	Limit (dB)	Margin (dB)	Remark	Table Deg.	Ant High (cm)
4875.78	40.15	5.05	45.19	74.00	-28.81	Peak	34	100
4875.78	28.99	5.05	34.03	54.00	-19.97	Average	34	100

Notes:

1. Result = Meter Reading + Corrected Factor
2. Corrected Factor = Antenna Factor + Cable Loss - Amplifier
3. The resolution bandwidth of test receiver/spectrum analyzer is 120KHz and video bandwidth is 300kHz for Peak detection and Quasi-peak detection at frequency below 1GHz.
4. The resolution bandwidth of test receiver/spectrum analyzer is 1MHz and video bandwidth is 3MHz for Peak detection at frequency above 1GHz.
5. The resolution bandwidth of test receiver/spectrum analyzer is 1MHz and video bandwidth is 10Hz for Average detection at frequency above 1GHz.
6. The other emissions is too low to be measured.

```

EUT           : WG111V2
Power         : DC 5V from PC
Test Mode     : Transmit/Receive
Operation Channel: 6
Modulation Type : 802.11b
Rate         : 11 Mbps
Memo         :

Pol/Phase    : VERTICAL
Temperature   : 14 °C
Humidity     : 70 %
Atmospheric Pressure: 1032 mmHg
    
```

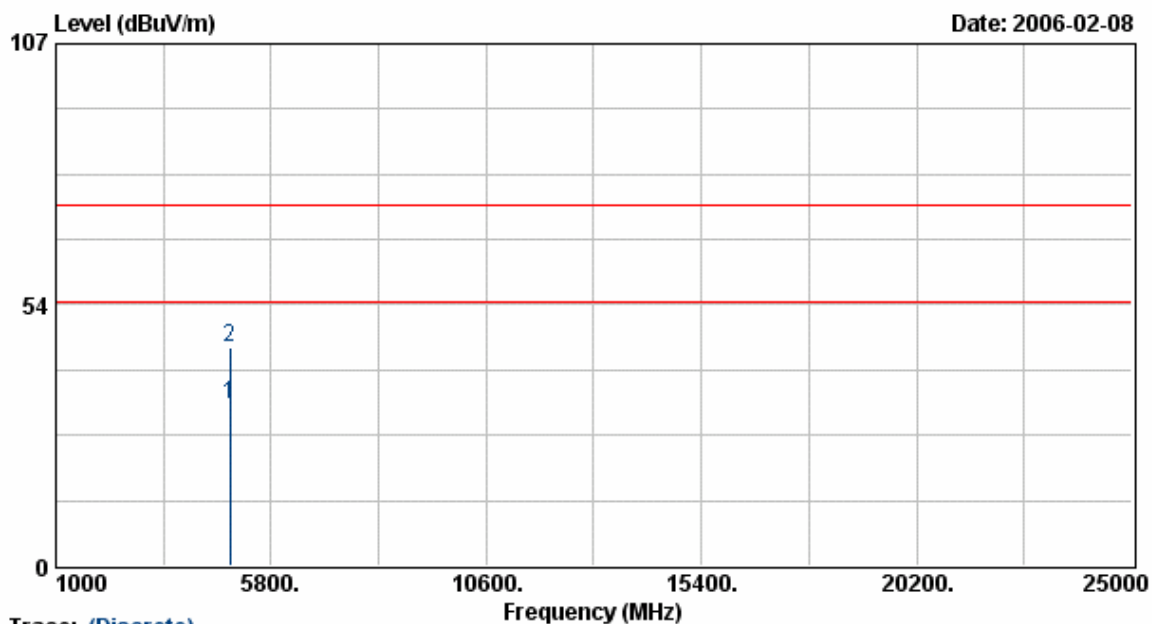

Trace: (Discrete)

Frequency (MHz)	Meter Reading (dBuV)	Corrected Factor (dBuV/m)	Result (dBuV/m)	Limit (dB)	Margin (dB)	Remark	Table Deg.	Ant High (cm)
4873.39	27.95	5.04	32.99	54.00	-21.01	Average	294	100
4873.39	39.65	5.04	44.69	74.00	-29.31	Peak	294	100

Notes:

1. Result = Meter Reading + Corrected Factor
2. Corrected Factor = Antenna Factor + Cable Loss - Amplifier
3. The resolution bandwidth of test receiver/spectrum analyzer is 120KHz and video bandwidth is 300kHz for Peak detection and Quasi-peak detection at frequency below 1GHz.
4. The resolution bandwidth of test receiver/spectrum analyzer is 1MHz and video bandwidth is 3MHz for Peak detection at frequency above 1GHz.
5. The resolution bandwidth of test receiver/spectrum analyzer is 1MHz and video bandwidth is 10Hz for Average detection at frequency above 1GHz.
6. The other emissions is too low to be measured.

EUT : WG111V2
 Power : DC 5V from PC
 Test Mode : Transmit/Receive
 Operation Channel: 11
 Modulation Type : 802.11b
 Rate : 11 Mbps
 Memo :
 Pol/Phase : HORIZONTAL
 Temperature : 14 °C
 Humidity : 70 %
 Atmospheric Pressure: 1032 mmHg

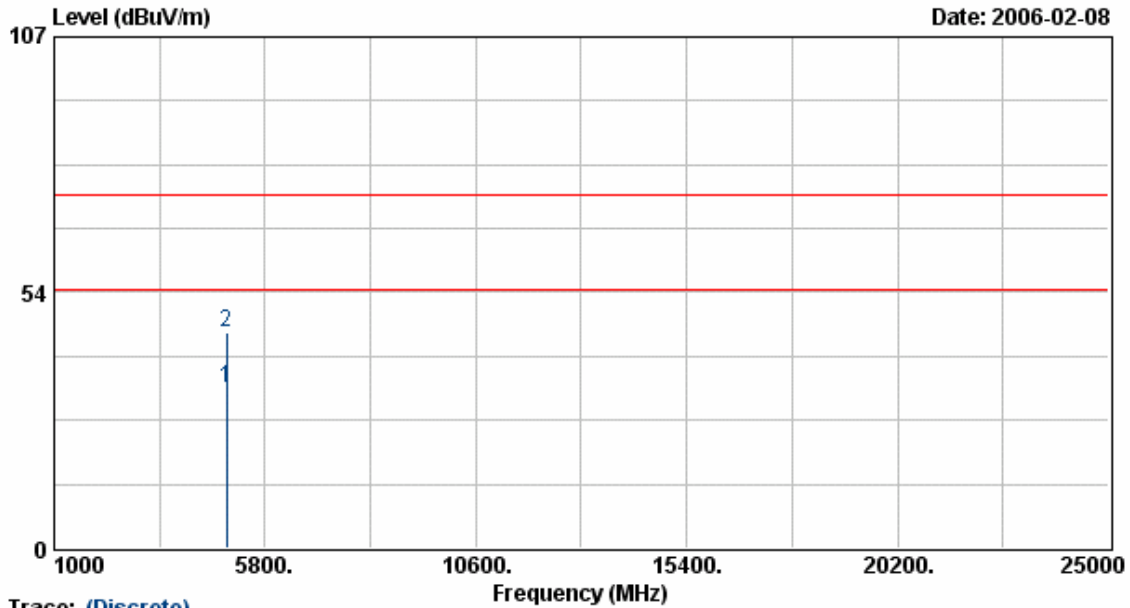

Trace: (Discrete)

Frequency (MHz)	Meter Reading (dBuV)	Corrected Factor (dBuV/m)	Result (dBuV/m)	Limit (dB)	Margin (dB)	Remark	Table Deg.	Ant High (cm)
4923.23	28.16	5.22	33.38	54.00	-20.62	Average	34	100
4923.23	39.98	5.22	45.20	74.00	-28.80	Peak	34	100

Notes:

1. Result = Meter Reading + Corrected Factor
2. Corrected Factor = Antenna Factor + Cable Loss - Amplifier
3. The resolution bandwidth of test receiver/spectrum analyzer is 120KHz and video bandwidth is 300kHz for Peak detection and Quasi-peak detection at frequency below 1GHz.
4. The resolution bandwidth of test receiver/spectrum analyzer is 1MHz and video bandwidth is 3MHz for Peak detection at frequency above 1GHz.
5. The resolution bandwidth of test receiver/spectrum analyzer is 1MHz and video bandwidth is 10Hz for Average detection at frequency above 1GHz.
6. The other emissions is too low to be measured.

```

EUT           : WG111V2
Power         : DC 5V from PC
Test Mode     : Transmit/Receive
Operation Channel: 11
Modulation Type : 802.11b
Rate         : 11 Mbps
Memo         :

Pol/Phase    : VERTICAL
Temperature   : 14 °C
Humidity     : 70 %
Atmospheric Pressure: 1032 mmHg
    
```

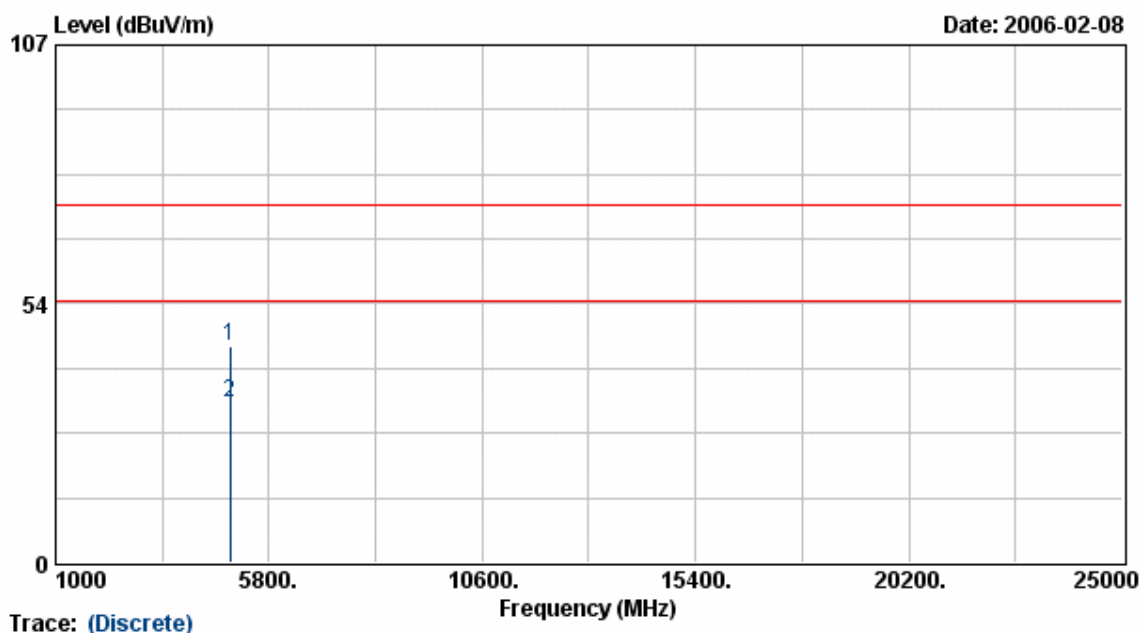

Trace: (Discrete)

Frequency (MHz)	Meter Reading (dBUV)	Corrected Factor (dBUV/m)	Result (dBUV/m)	Limit (dB)	Margin (dB)	Remark	Table Deg.	Ant High (cm)
4923.33	39.65	5.22	44.87	74.00	-29.13	Peak	294	100
4923.33	27.79	5.22	33.01	54.00	-20.99	Average	294	100

Notes:

1. Result = Meter Reading + Corrected Factor
2. Corrected Factor = Antenna Factor + Cable Loss - Amplifier
3. The resolution bandwidth of test receiver/spectrum analyzer is 120KHz and video bandwidth is 300kHz for Peak detection and Quasi-peak detection at frequency below 1GHz.
4. The resolution bandwidth of test receiver/spectrum analyzer is 1MHz and video bandwidth is 3MHz for Peak detection at frequency above 1GHz.
5. The resolution bandwidth of test receiver/spectrum analyzer is 1MHz and video bandwidth is 10Hz for Average detection at frequency above 1GHz.
6. The other emissions is too low to be measured.

```

EUT           : WG111V2
Power         : DC 5V from PC
Test Mode     : Transmit/Receive
Operation Channel: 1
Modulation Type : 802.11g
Rate         : 54 Mbps
Memo         :

Pol/Phase    : HORIZONTAL
Temperature   : 14 °C
Humidity     : 70 %
Atmospheric Pressure: 1032 mmHg
    
```

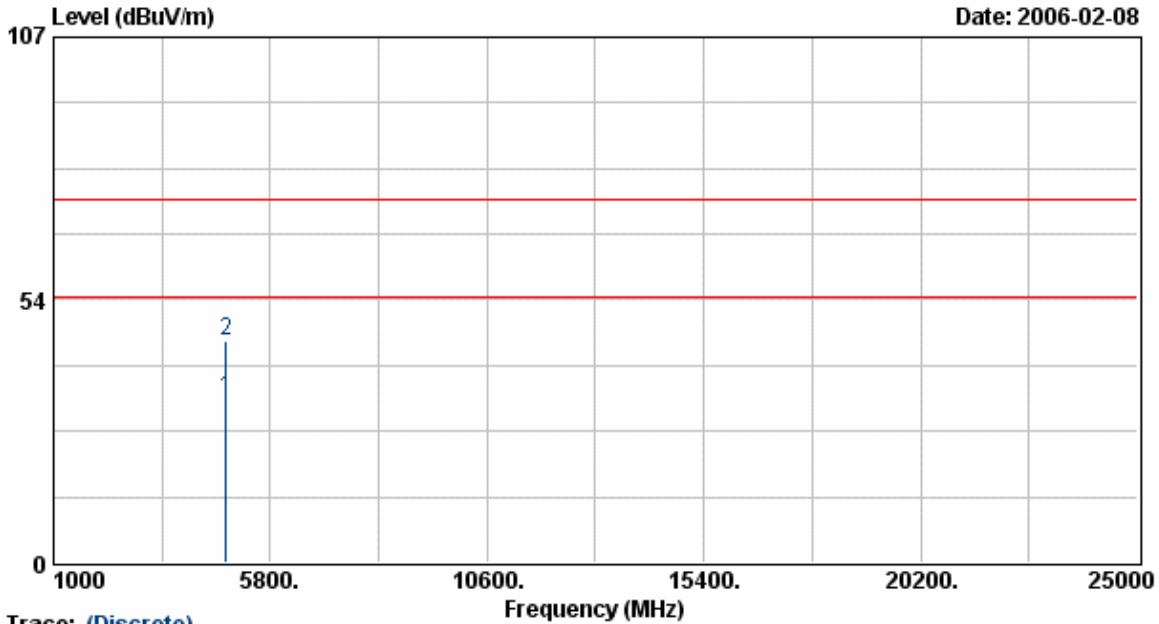

Trace: (Discrete)

Frequency (MHz)	Meter Reading (dBUV)	Corrected Factor (dBUV/m)	Result (dBUV/m)	Limit (dB)	Margin (dB)	Remark	Table Deg.	Ant High (cm)
4822.05	28.43	4.85	33.28	54.00	-20.72	Average	34	100
4822.05	40.33	4.85	45.18	74.00	-28.82	Peak	34	100

- Notes:
1. Result = Meter Reading + Corrected Factor
 2. Corrected Factor = Antenna Factor + Cable Loss - Amplifier
 3. The resolution bandwidth of test receiver/spectrum analyzer is 120KHz and video bandwidth is 300kHz for Peak detection and Quasi-peak detection at frequency below 1GHz.
 4. The resolution bandwidth of test receiver/spectrum analyzer is 1MHz and video bandwidth is 3MHz for Peak detection at frequency above 1GHz.
 5. The resolution bandwidth of test receiver/spectrum analyzer is 1MHz and video bandwidth is 10Hz for Average detection at frequency above 1GHz.
 6. The other emissions is too low to be measured.

```

EUT           : WG111V2
Power         : DC 5V from PC
Test Mode     : Transmit/Receive
Operation Channel: 1
Modulation Type : 802.11g
Rate         : 54 Mbps
Memo         :
Pol/Phase     : VERTICAL
Temperature   : 14 °C
Humidity      : 70 %
Atmospheric Pressure: 1032 mmHg
    
```

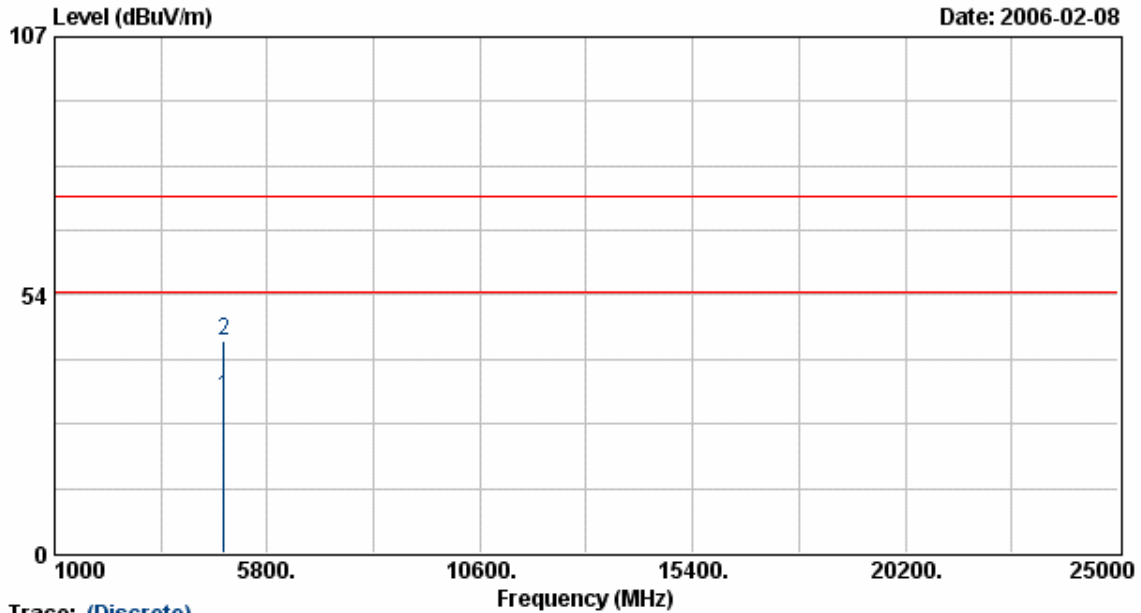

Trace: (Discrete)

Frequency (MHz)	Meter Reading (dBUV)	Corrected Factor (dBUV/m)	Result (dBUV/m)	Limit (dB)	Margin (dB)	Remark	Table Deg.	Ant High (cm)
4823.90	27.40	4.86	32.26	54.00	-21.74	Average	294	100
4823.90	38.92	4.86	43.78	74.00	-30.22	Peak	294	100

Notes:

1. Result = Meter Reading + Corrected Factor
2. Corrected Factor = Antenna Factor + Cable Loss - Amplifier
3. The resolution bandwidth of test receiver/spectrum analyzer is 120KHz and video bandwidth is 300kHz for Peak detection and Quasi-peak detection at frequency below 1GHz.
4. The resolution bandwidth of test receiver/spectrum analyzer is 1MHz and video bandwidth is 3MHz for Peak detection at frequency above 1GHz.
5. The resolution bandwidth of test receiver/spectrum analyzer is 1MHz and video bandwidth is 10Hz for Average detection at frequency above 1GHz.
6. The other emissions is too low to be measured.

```

EUT           : WG111V2
Power         : DC 5V from PC
Test Mode     : Transmit/Receive
Operation Channel: 6
Modulation Type : 802.11g
Rate         : 54 Mbps
Memo         :

Pol/Phase     : HORIZONTAL
Temperature   : 14 °C
Humidity      : 70 %
Atmospheric Pressure: 1032 mmHg
    
```

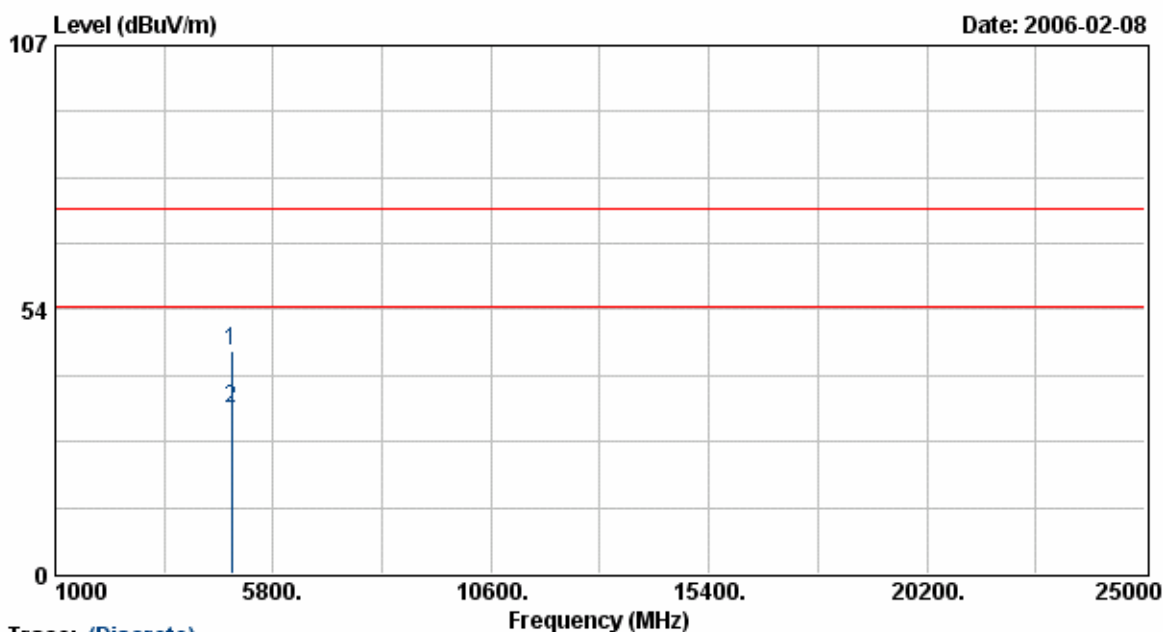

Trace: (Discrete)

Frequency (MHz)	Meter Reading (dBuV)	Corrected Factor (dBuV/m)	Result (dBuV/m)	Limit (dB)	Margin (dB)	Remark	Table Deg.	Ant High (cm)
4875.13	40.23	5.05	45.27	74.00	-28.73	Peak	34	100
4875.22	28.32	5.05	33.37	54.00	-20.63	Average	34	100

Notes:

1. Result = Meter Reading + Corrected Factor
2. Corrected Factor = Antenna Factor + Cable Loss - Amplifier
3. The resolution bandwidth of test receiver/spectrum analyzer is 120KHz and video bandwidth is 300kHz for Peak detection and Quasi-peak detection at frequency below 1GHz.
4. The resolution bandwidth of test receiver/spectrum analyzer is 1MHz and video bandwidth is 3MHz for Peak detection at frequency above 1GHz.
5. The resolution bandwidth of test receiver/spectrum analyzer is 1MHz and video bandwidth is 10Hz for Average detection at frequency above 1GHz.
6. The other emissions is too low to be measured.

```

EUT           : WG111V2
Power         : DC 5V from PC
Test Mode     : Transmit/Receive
Operation Channel: 6
Modulation Type : 802.11g
Rate         : 54 Mbps
Memo          :

Pol/Phase     : VERTICAL
Temperature   : 14 °C
Humidity      : 70 %
Atmospheric Pressure: 1032 mmHg
    
```

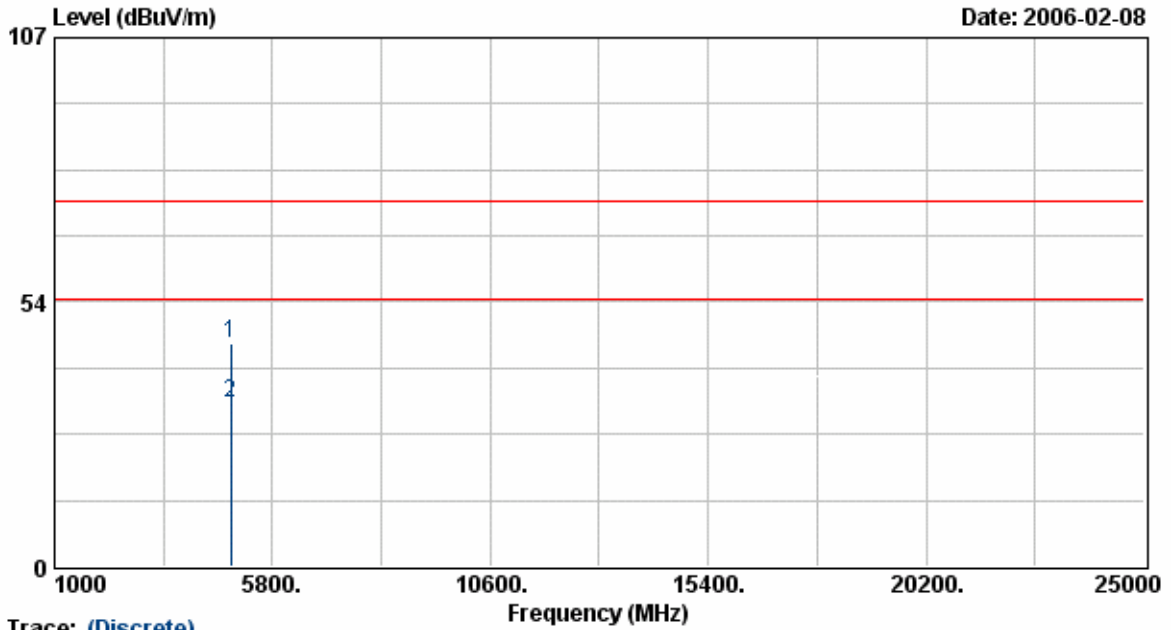

Trace: (Discrete)

Frequency (MHz)	Meter Reading (dBUV)	Corrected Factor (dBUV/m)	Result (dBUV/m)	Limit (dB)	Margin (dB)	Remark	Table Deg.	Ant High (cm)
4873.68	39.97	5.04	45.01	74.00	-28.99	Peak	294	100
4873.68	28.07	5.04	33.11	54.00	-20.89	Average	294	100

- Notes:
1. Result = Meter Reading + Corrected Factor
 2. Corrected Factor = Antenna Factor + Cable Loss - Amplifier
 3. The resolution bandwidth of test receiver/spectrum analyzer is 120KHz and video bandwidth is 300kHz for Peak detection and Quasi-peak detection at frequency below 1GHz.
 4. The resolution bandwidth of test receiver/spectrum analyzer is 1MHz and video bandwidth is 3MHz for Peak detection at frequency above 1GHz.
 5. The resolution bandwidth of test receiver/spectrum analyzer is 1MHz and video bandwidth is 10Hz for Average detection at frequency above 1GHz.
 6. The other emissions is too low to be measured.

EUT : WG111V2
 Power : DC 5V from PC
 Test Mode : Transmit/Receive
 Operation Channel : 11
 Modulation Type : 802.11g
 Rate : 54 Mbps
 Memo :
 Pol/Phase : HORIZONTAL
 Temperature : 14 °C
 Humidity : 70 %
 Atmospheric Pressure : 1032 mmHg

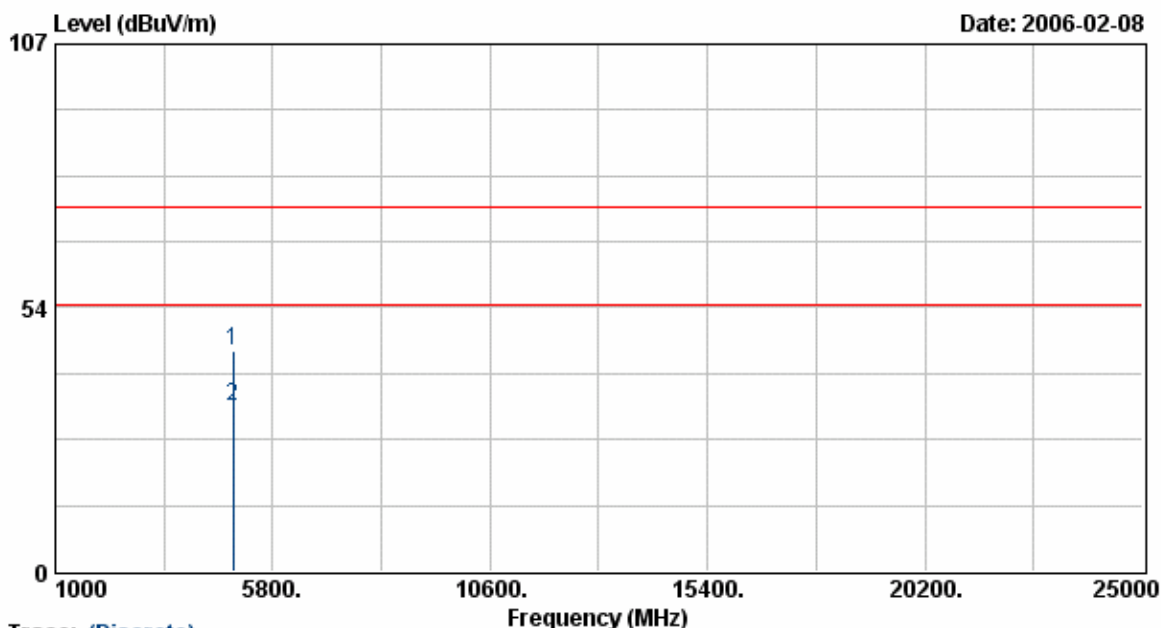

Trace: (Discrete)

Frequency (MHz)	Meter Reading (dBuV)	Corrected Factor (dBuV/m)	Result (dBuV/m)	Limit (dB)	Margin (dB)	Remark	Table Deg.	Ant High (cm)
4922.40	39.67	5.22	44.88	74.00	-29.12	Peak	34	100
4922.40	28.43	5.22	33.65	54.00	-20.35	Average	34	100

Notes:

1. Result = Meter Reading + Corrected Factor
2. Corrected Factor = Antenna Factor + Cable Loss - Amplifier
3. The resolution bandwidth of test receiver/spectrum analyzer is 120KHz and video bandwidth is 300kHz for Peak detection and Quasi-peak detection at frequency below 1GHz.
4. The resolution bandwidth of test receiver/spectrum analyzer is 1MHz and video bandwidth is 3MHz for Peak detection at frequency above 1GHz.
5. The resolution bandwidth of test receiver/spectrum analyzer is 1MHz and video bandwidth is 10Hz for Average detection at frequency above 1GHz.
6. The other emissions is too low to be measured.

```

EUT           : WG111V2
Power         : DC 5V from PC
Test Mode     : Transmit/Receive
Operation Channel: 11
Modulation Type : 802.11g
Rate          : 54 Mbps
Memo          :

Pol/Phase     : VERTICAL
Temperature   : 14 °C
Humidity      : 70 %
Atmospheric Pressure: 1032 mmHg
    
```

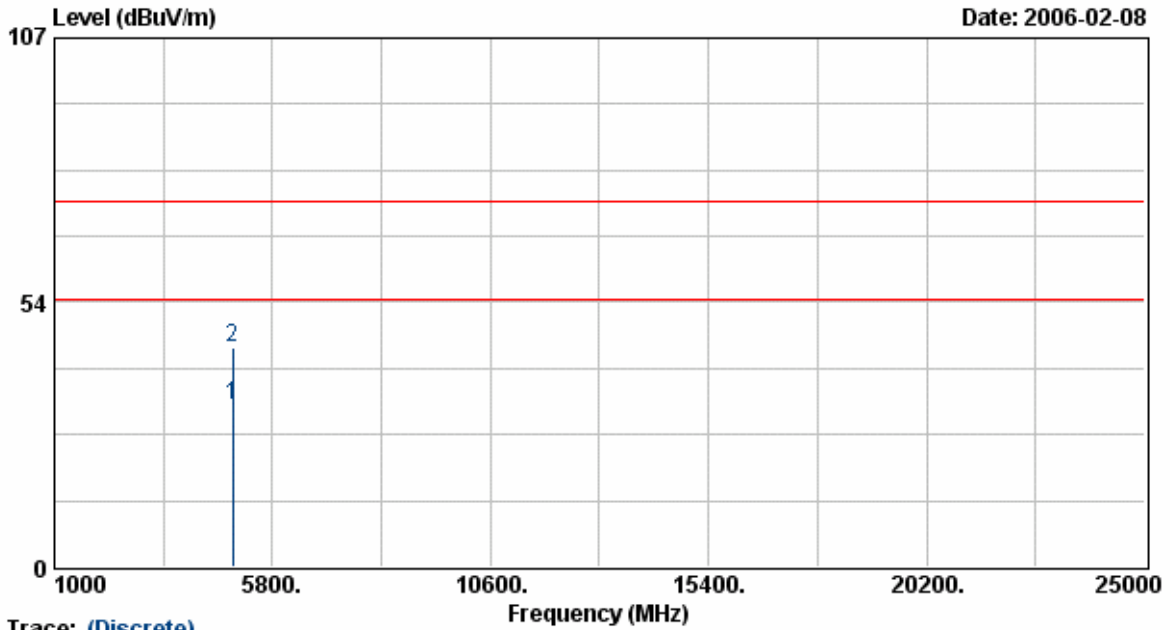

Trace: (Discrete)

Frequency (MHz)	Meter Reading (dBuV)	Corrected Factor (dBuV/m)	Result (dBuV/m)	Limit (dB)	Margin (dB)	Remark	Table Deg.	Ant High (cm)
4923.87	27.64	5.22	32.86	54.00	-21.14	Average	294	100
4923.87	39.15	5.22	44.38	74.00	-29.62	Peak	294	100

Notes:

1. Result = Meter Reading + Corrected Factor
2. Corrected Factor = Antenna Factor + Cable Loss - Amplifier
3. The resolution bandwidth of test receiver/spectrum analyzer is 120KHz and video bandwidth is 300kHz for Peak detection and Quasi-peak detection at frequency below 1GHz.
4. The resolution bandwidth of test receiver/spectrum analyzer is 1MHz and video bandwidth is 3MHz for Peak detection at frequency above 1GHz.
5. The resolution bandwidth of test receiver/spectrum analyzer is 1MHz and video bandwidth is 10Hz for Average detection at frequency above 1GHz.
6. The other emissions is too low to be measured.

6. 6dB Bandwidth Measurement Data

6.1 Test Limit

The minimum of 6dB Bandwidth Measurement is 0.5 MHz.

6.2 Test Procedures

1. The transmitter output was connected to the spectrum analyzer.
2. Set RBW of spectrum analyzer to 100 KHz and VBW to 100 KHz.
3. The 6 dB bandwidth is defined as the total spectrum the power of which is higher than peak power minus 6 dB.

6.3 Test Setup Layout

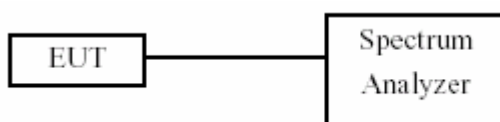

6.4 Measurement equipment

Instrument/Ancillary	Model No.	Manufacturer	Serial No.	Valid Date.
Spectrum Analyzer	FSP40	R&S	100047	2007/01/16

6.5 Test Result and Data

(1) Modulation Standard: IEEE 802.11b (11Mbps)

Test Date: Feb. 06, 2006 Temperature: 22 Humidity: 70% Atmospheric pressure: 1026 mmHg

Channel	Frequency (MHz)	6dB Bandwidth (MHz)
01	2412	8.8
06	2437	8.9
11	2462	8.8

(2) Modulation Standard: IEEE 802.11g (54Mbps)

Test Date: Feb. 06, 2006 Temperature: 22 Humidity: 70% Atmospheric pressure: 1026 mmHg

Channel	Frequency (MHz)	6dB Bandwidth (MHz)
01	2412	16.5
06	2437	16.4
11	2462	16.5

Modulation Standard: 802.11b (11Mbps)
 Channel: 01

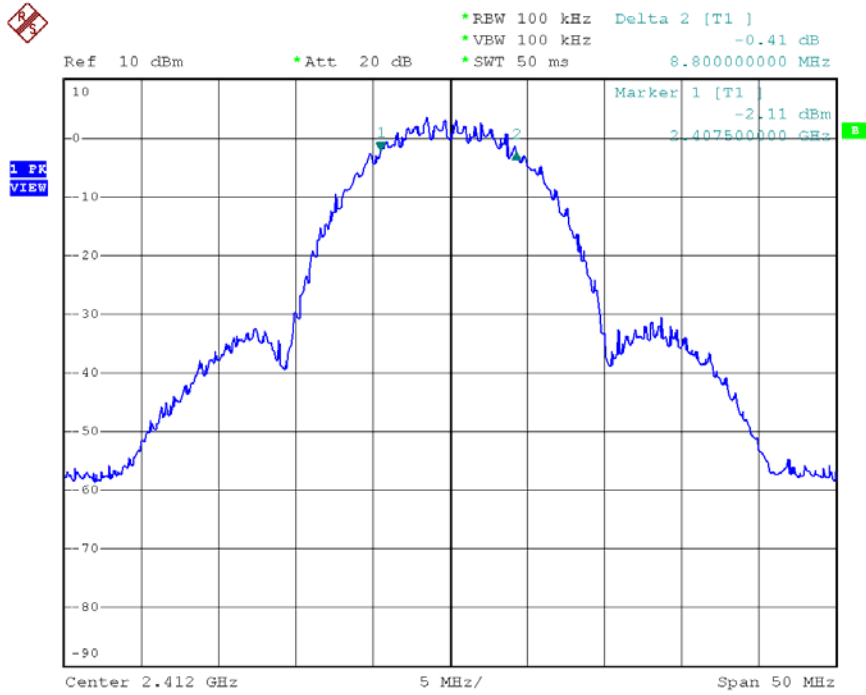

Date: 6.FEB.2006 11:19:15

Channel:06

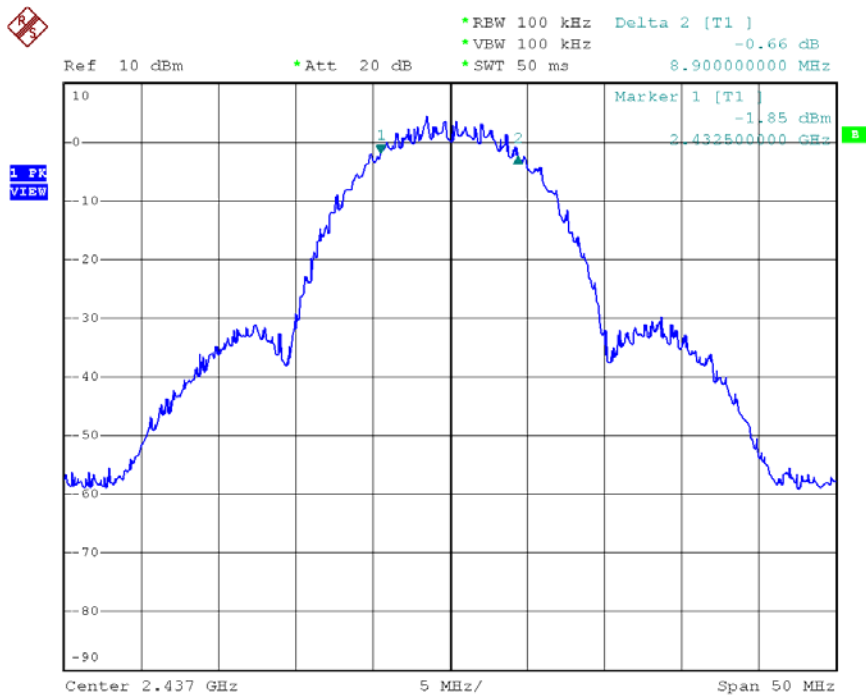

Date: 6.FEB.2006 11:31:27

Channel: 11

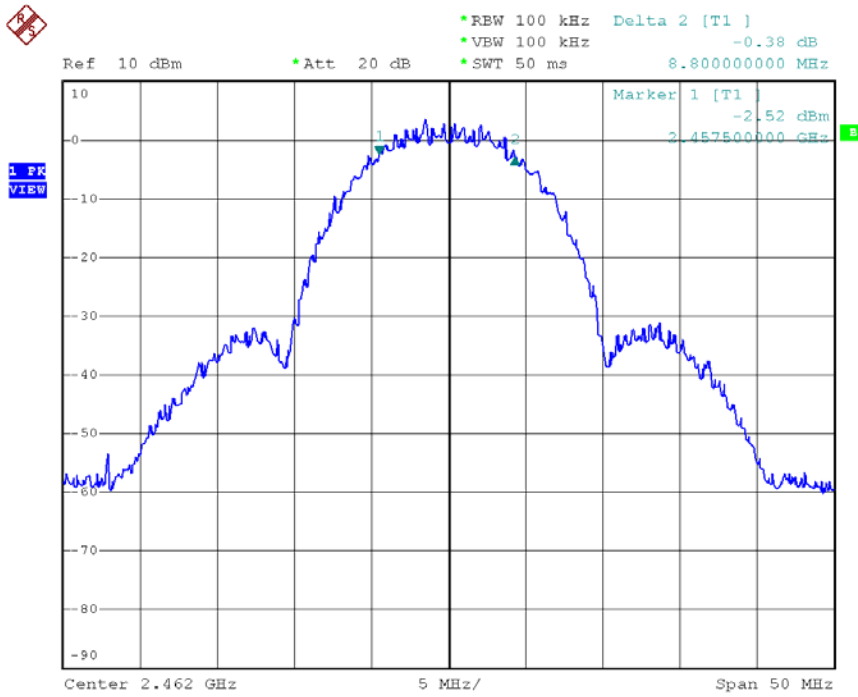

Date: 6.FEB.2006 11:32:54

Modulation Standard:802.11g (54Mbps)
Channel:01

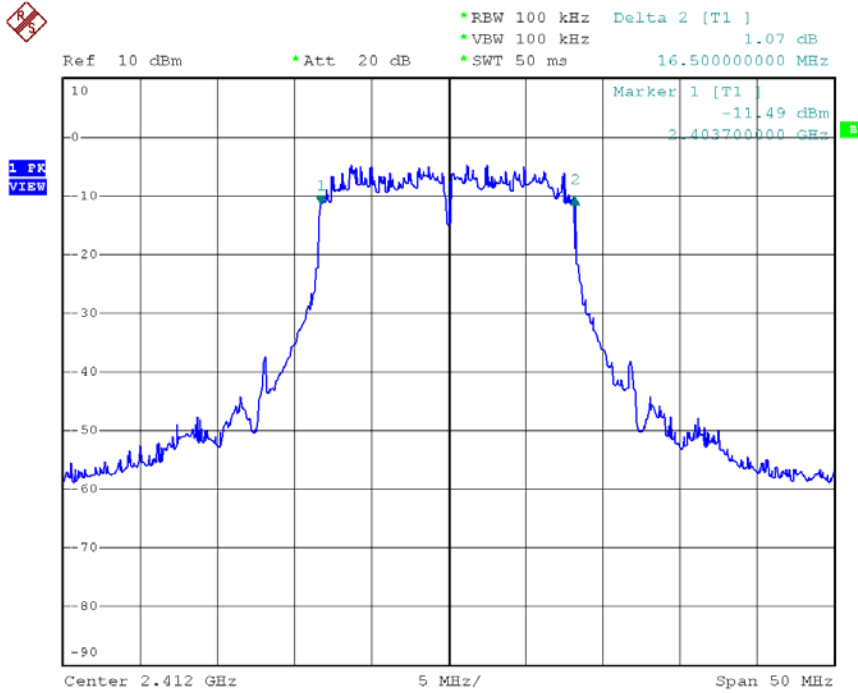

Date: 6.FEB.2006 11:49:54

Channel: 06

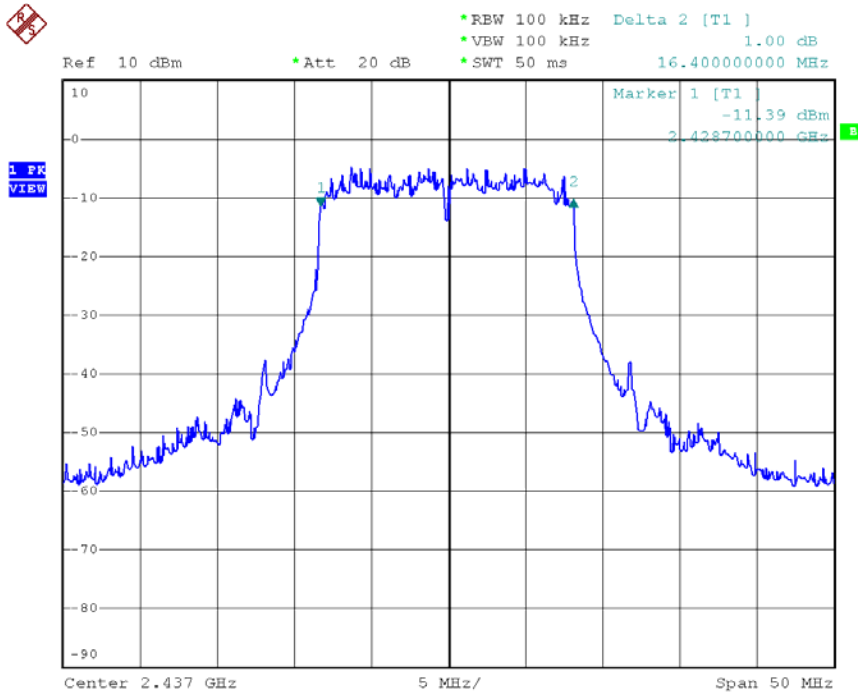

Date: 6.FEB.2006 11:46:45

Channel:11

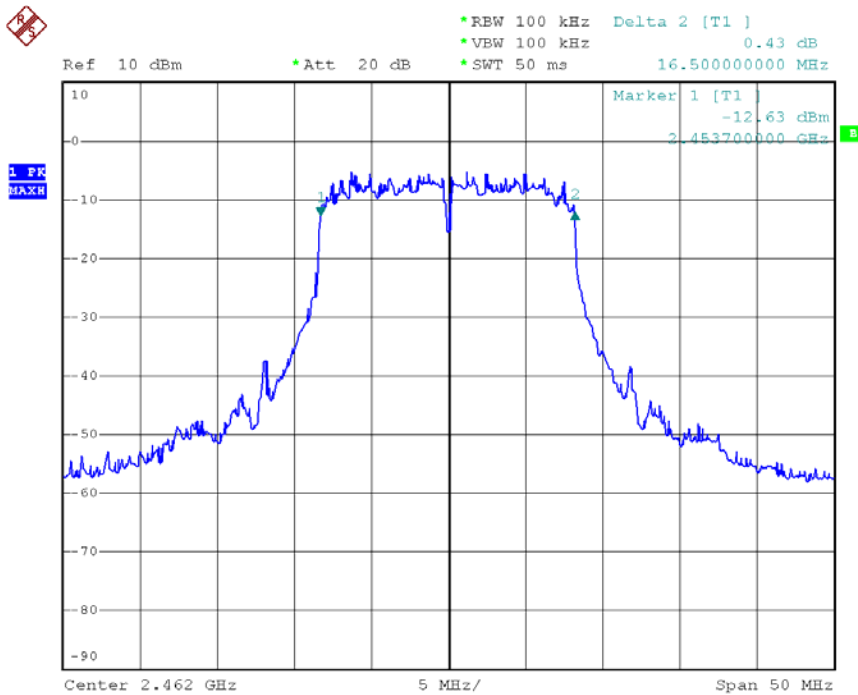

Date: 6.FEB.2006 11:42:04

7. Maximum Peak Output Power

7.1 Test Limit

The Maximum Peak Output Power Measurement is 30dBm.

7.2 Test Procedures

The antenna port(RF output)of the EUT was connected to the input(RF input)of a power meter. Power was read directly from the meter and cable loss connection was added to the reading to obtain power at the EUT antenna terminal. The EUT Output Power was set to maximum to produce the worse case test result.

7.3 Test Setup Layout

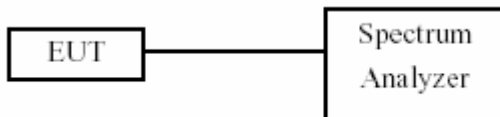

7.4 List of Measuring Equipment Used

Instrument/Ancillary	Model No.	Manufacturer	Serial No.	Valid Date.
Spectrum Analyzer	FSP40	R&S	100047	2007/01/16

7.5 Test Result and Data

(1) Modulation Standard: IEEE 802.11b (11Mbps)

Test Date: Feb. 06, 2006 Temperature: 22 Humidity: 70% Atmospheric pressure: 1026 mmHg

Channel	Frequency (MHz)	Peak Power Output (dBm)	Peak Power Output (mW)
01	2412	19.25	84.10
06	2437	19.27	84.50
11	2462	19.44	87.90

(2) Modulation Standard: IEEE 802.11g (54Mbps)

Test Date: Feb. 06, 2006 Temperature: 22 Humidity: 70% Atmospheric pressure: 1026 mmHg

Channel	Frequency (MHz)	Peak Power Output (dBm)	Peak Power Output (mW)
01	2412	15.20	33.10
06	2437	15.20	32.40
11	2462	15.06	32.10

Modulation Standard: 802.11b (11Mbps)
 Channel: 01

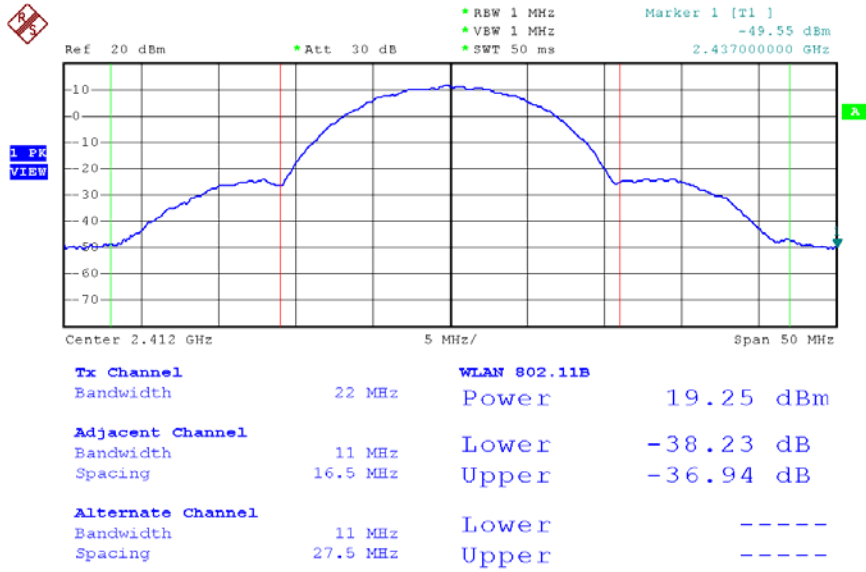

Date: 6.FEB.2006 10:56:14

Channel:06

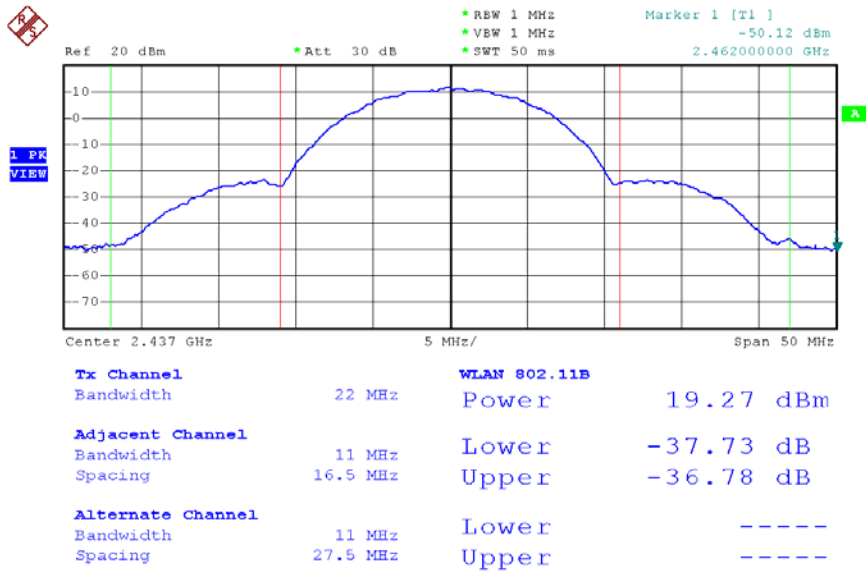

Date: 6.FEB.2006 10:55:16

Channel: 11

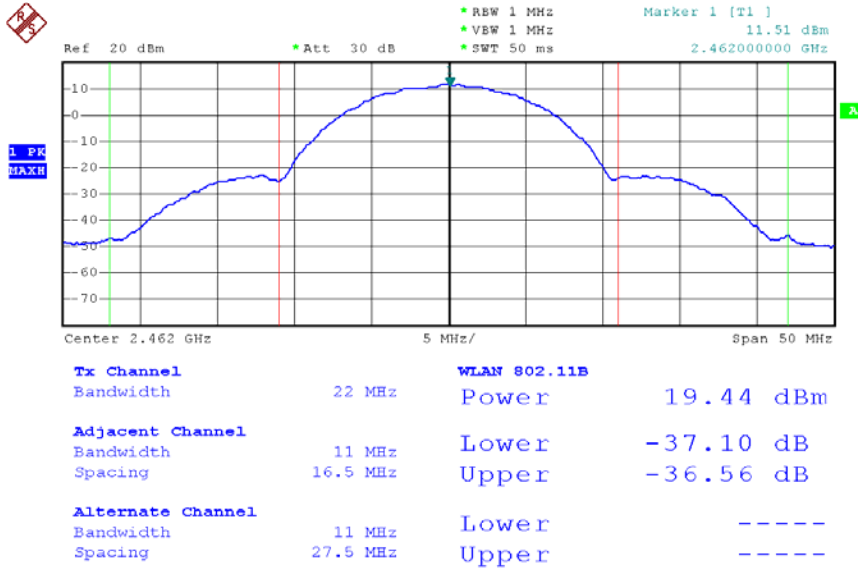

Date: 6.FEB.2006 10:53:24

Modulation Standard:802.11g (54Mbps)
Channel:01

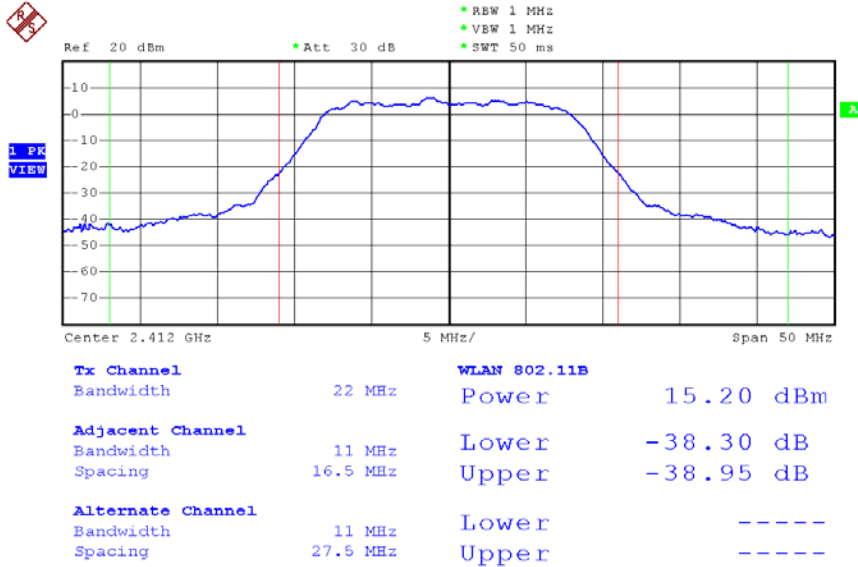

Date: 6.FEB.2006 11:13:34

Channel: 06

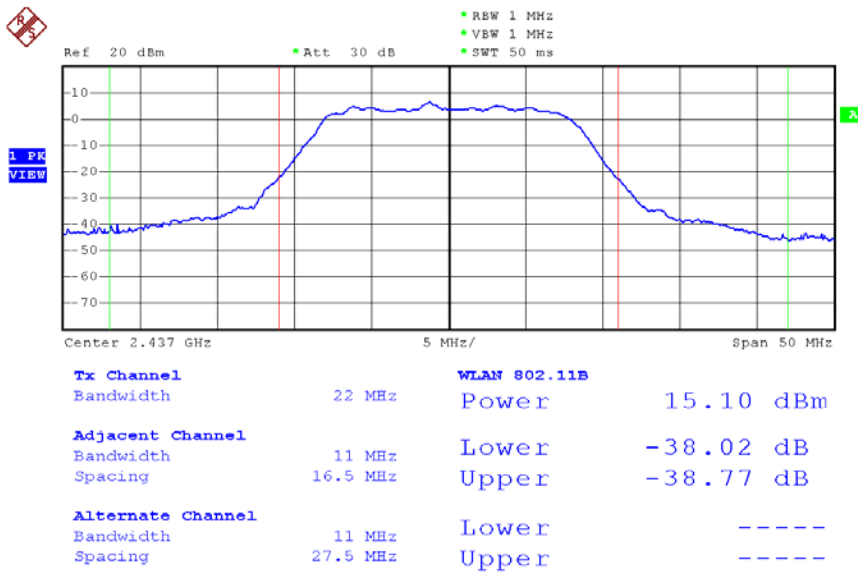

Date: 6.FEB.2006 11:09:49

Channel:11

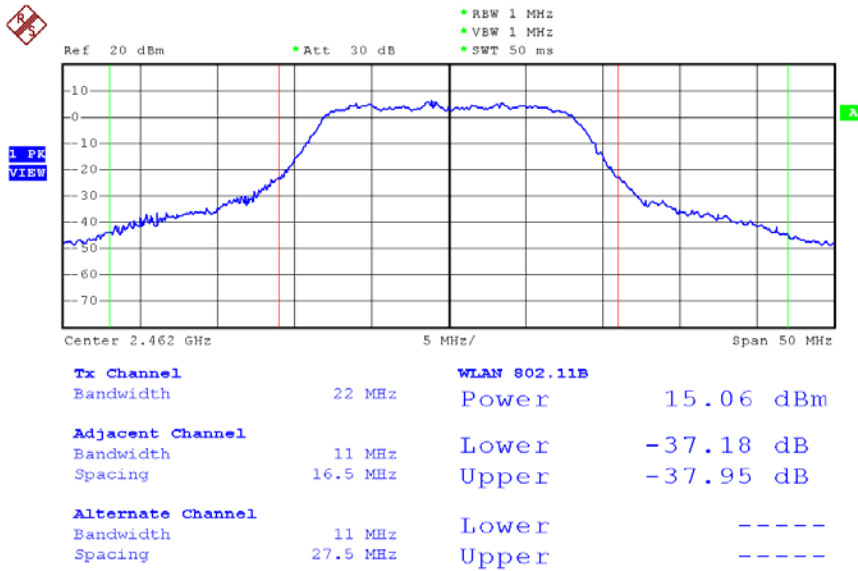

Date: 23.MAR.2006 17:22:35

8. Band Edges Measurement

8.1 Test Limit

Below -20dB of the highest emission level of operating band
(in 100kHz Resolution Bandwidth).

8.2 Test Procedure :

- 1.The transmitter output was connected to the spectrum analyzer via a low lose cable.
- 2.Set both RBW and VBW of spectrum analyzer to 100 KHz with convenient frequency span including 100 KHz bandwidth from band edge.
- 3.The band edges was measured and recorded.

8.3 Test Setup Layout

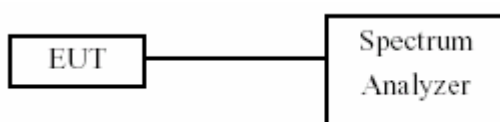

8.4 List of Measuring Equipment Used

Instrument/Ancillary	Model No.	Manufacturer	Serial No.	Valid Date.
Spectrum Analyzer	FSP40	R&S	100047	2007/01/16

8.5 Test Result and Data

(1) Modulation Standard: IEEE 802.11b (11Mbps)

Test Date: Feb. 06, 2006 Temperature: 22 Humidity: 70% Atmospheric pressure: 1026 mmHg

Channel	Frequency	maximum value in frequency (MHz)	maximum value is (dBm)
01	2412	2399.4	-32.03
11	2462	20635.0	-53.30

(2) Modulation Standard: IEEE 802.11g (54Mbps)

Test Date: Feb. 06, 2006 Temperature: 22 Humidity: 70% Atmospheric pressure: 1026 mmHg

Channel	Frequency	maximum value in frequency (MHz)	maximum value is (dBm)
01	2412	2399.8	-44.28
11	2462	2483.7	-53.47

Modulation Standard: 802.11b (11Mbps)

Channel: 01

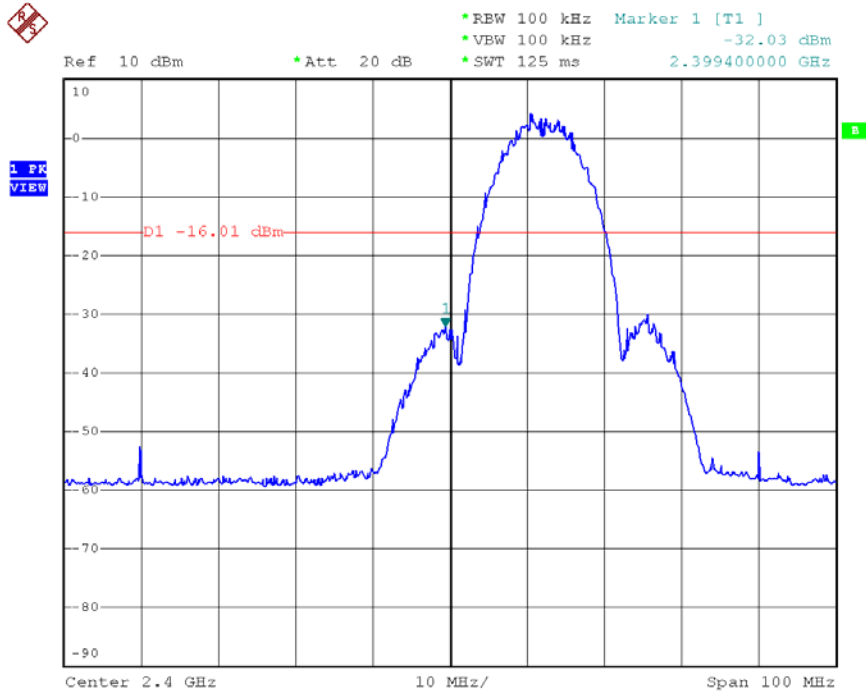

Date: 6.FEB.2006 12:03:24

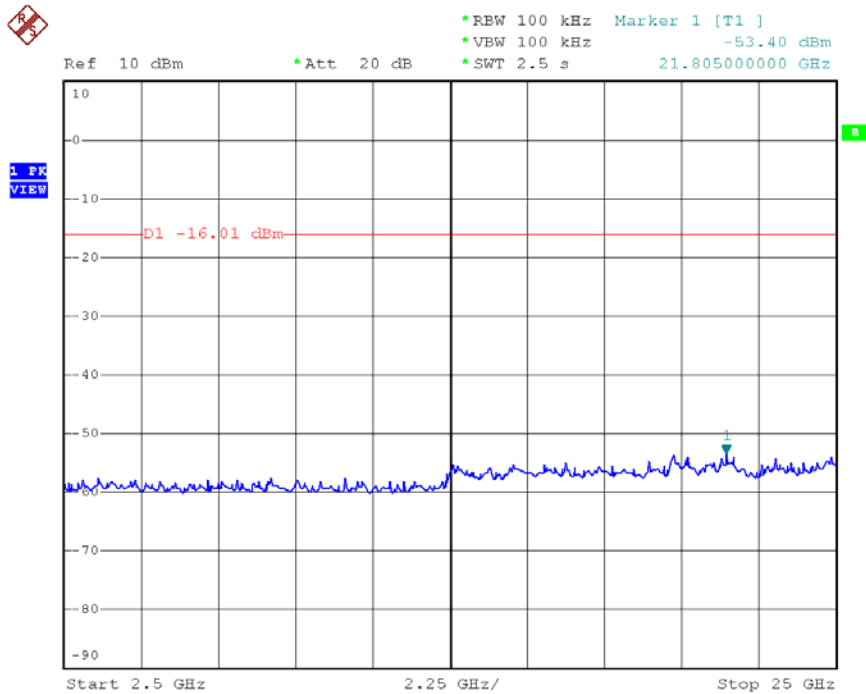

Date: 6.FEB.2006 12:04:51

Channel: 11

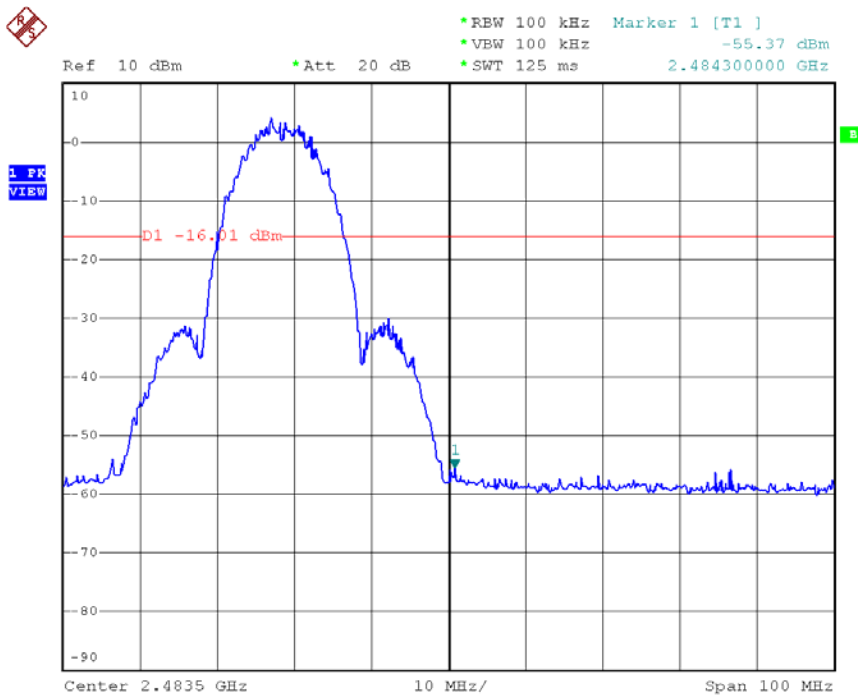

Date: 6.FEB.2006 13:18:15

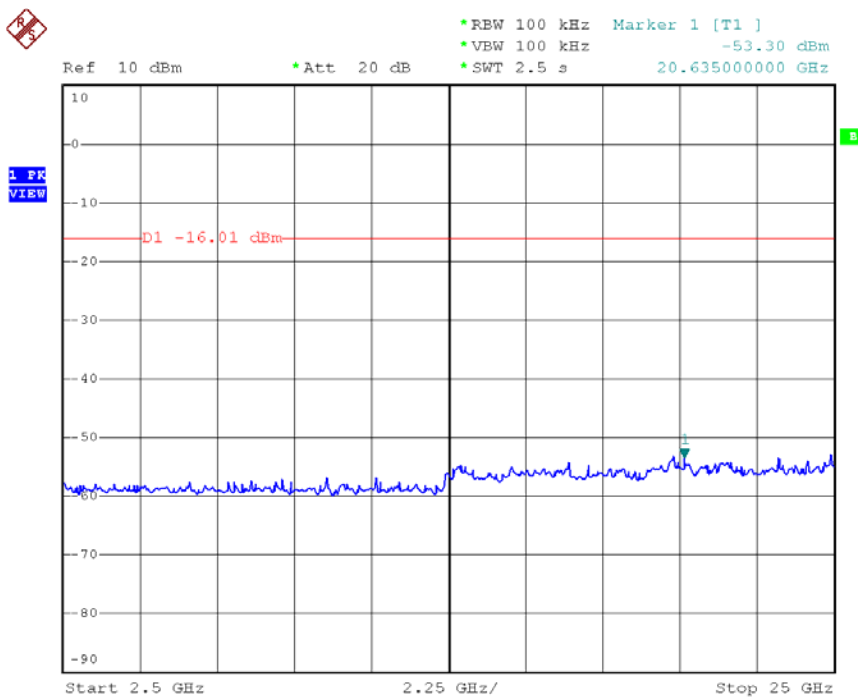

Date: 6.FEB.2006 13:20:06

Modulation Standard: 802.11g (54Mbps)

Channel: 01

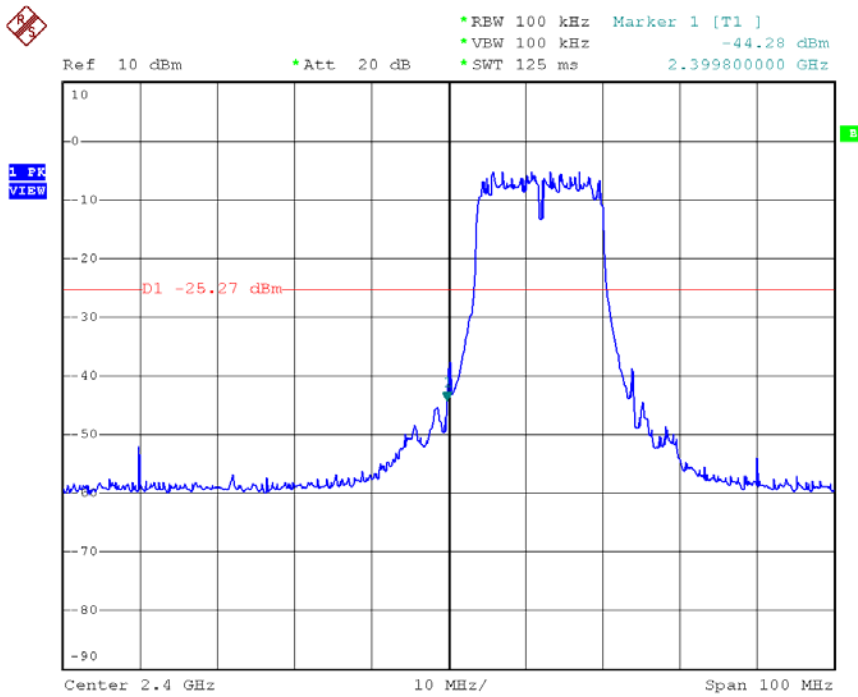

Date: 6.FEB.2006 13:22:32

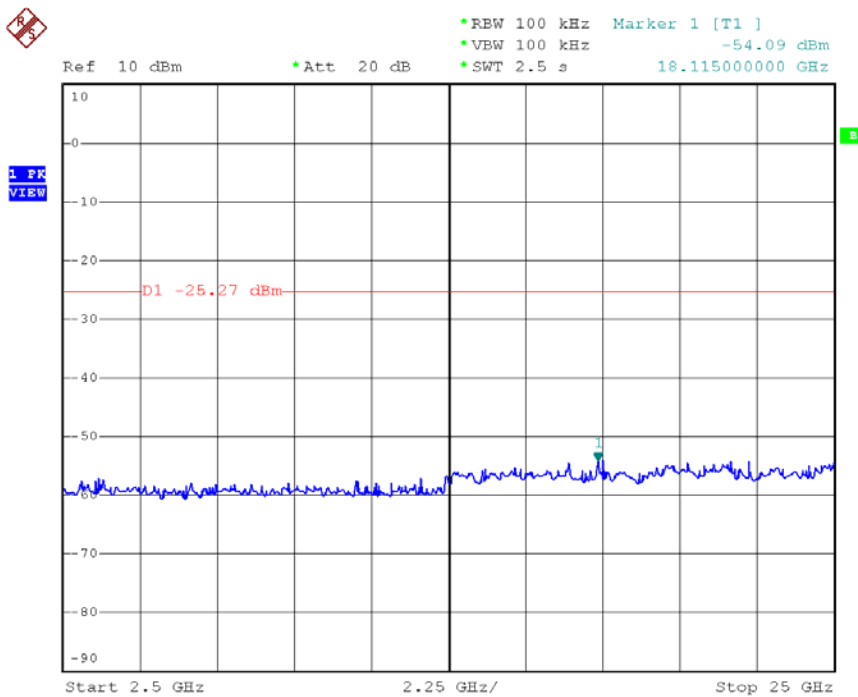

Date: 6.FEB.2006 13:23:26

Channel: 11

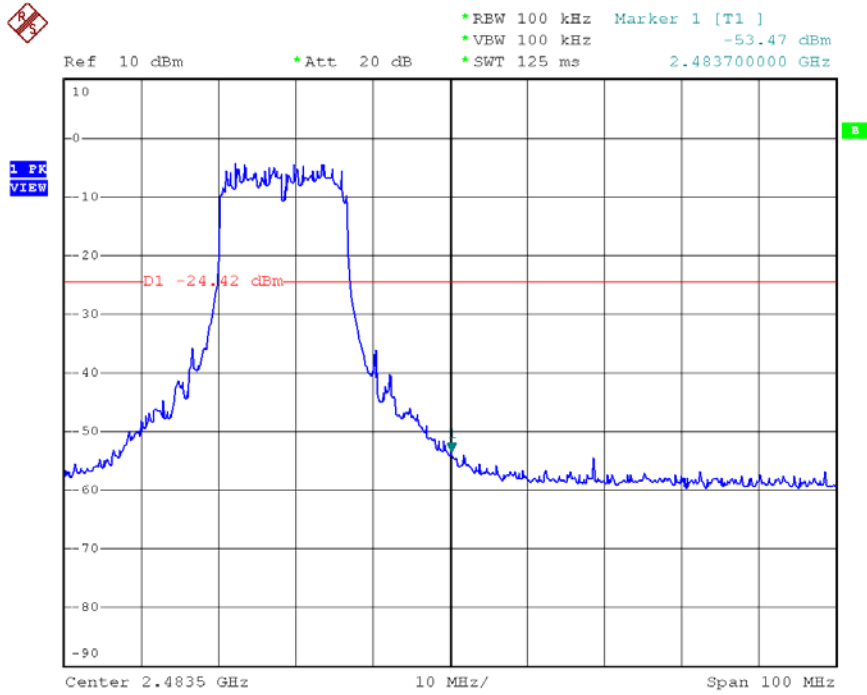

Date: 23.MAR.2006 17:37:43

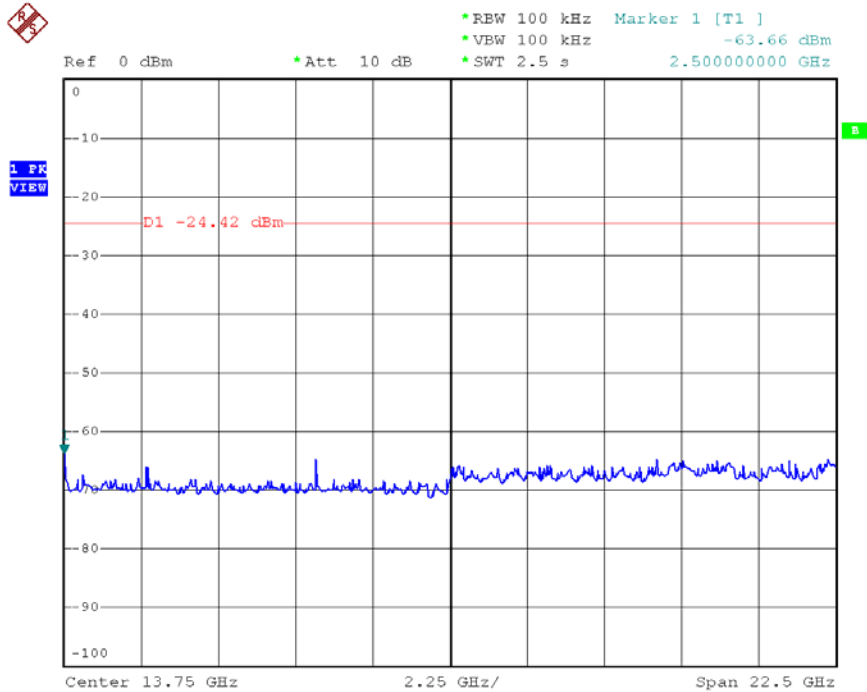

Date: 23.MAR.2006 17:40:35

8.6 Restrict band emission Measurement Data

Modulation Standard: IEEE 802.11b (11Mbps)

Test Date: Feb. 08, 2006 Temperature: 14 Humidity: 70% Atmospheric pressure: 1032 mmHg

a) Channel 1

Frequency (MHz)	Ant-Pol H/V	Meter Reading	Corrected Factor	Result (dBuV/m)	Remark	Limit@3m (dBuV/m)		Margin (dB)	Table (Deg.)	Ant High (m)
						Peak	Ave.			
2364.978	H	54.03	-2.14	51.89	Peak	74	54	-22.01	34	1.0
2371.404	H	43.36	-2.11	41.25	Ave	74	54	-12.75	34	1.0
2378.034	V	52.64	-2.09	50.55	Peak	74	54	-23.45	294	1.0
2375.484	V	40.36	-2.10	38.26	Ave	74	54	-15.74	294	1.0

b) Channel 11

Frequency (MHz)	Ant-Pol H/V	Meter Reading	Corrected Factor	Result (dBuV/m)	Remark	Limit@3m (dBuV/m)		Margin (dB)	Table (Deg.)	Ant High (m)
						Peak	Ave.			
2495.022	H	52.67	-1.69	50.98	Peak	74	54	-23.02	34	1.0
2500.000	H	40.61	-1.69	38.94	Ave	74	54	-15.06	34	1.0
2487.422	V	52.33	-1.71	50.62	Peak	74	54	-23.38	294	1.0
2492.020	V	40.50	-1.70	38.80	Ave	74	54	-15.20	294	1.0

Modulation Standard: 802.11g (54Mbps)

Test Date: Feb. 08, 2006 Temperature: 14 Humidity: 70% Atmospheric pressure: 1032 mmHg

a) Channel 1

Frequency (MHz)	Ant-Pol H/V	Meter Reading	Corrected Factor	Result (dBuV/m)	Remark	Limit@3m (dBuV/m)		Margin (dB)	Table (Deg.)	Ant High (m)
						Peak	Ave.			
2389.764	H	56.02	-2.05	53.97	Peak	74	54	-20.03	34	1.0
2389.968	H	44.32	-2.05	42.27	Ave	74	54	-11.73	34	1.0
2361.714	V	52.78	-2.15	50.63	Peak	74	54	-23.37	294	1.0
2389.968	V	40.27	-2.05	38.22	Ave	74	54	-15.78	294	1.0

b) Channel 11

Frequency (MHz)	Ant-Pol H/V	Meter Reading	Corrected Factor	Result (dBuV/m)	Remark	Limit@3m (dBuV/m)		Margin (dB)	Table (Deg.)	Ant High (m)
						Peak	Ave.			
2483.508	H	55.26	-1.73	53.53	Peak	74	54	-20.47	34	1.0
2483.508	H	43.23	-1.73	41.50	Ave	74	54	-12.50	34	1.0
2491.032	V	52.46	-1.70	50.76	Peak	74	54	-23.24	294	1.0
2483.508	V	40.26	-1.73	38.53	Ave	74	54	-15.47	294	1.0

Notes:

1. Result = Meter Reading + Factor
2. Factor = Antenna Factor + Cable Loss – Amplifier
3. The resolution bandwidth of test receiver/spectrum analyzer is 1 MHz and video bandwidth is 3 MHz for Peak detection at frequency above 1GHz.
4. The resolution bandwidth of test receiver/spectrum analyzer is 1MHz and video bandwidth is 10Hz for Average detection at frequency above 1GHz

9. Power Spectral Density

9.1 Test Limit

The Maximum of Power Spectral Density Measurement is 8dBm.

9.2 Test Procedures

- 1.The transmitter output was connected to spectrum analyzer.
- 2.The spectrum analyzer's resolution bandwidth were set at 3KHz RBW and 30KHz VBW as that of the fundamental frequency. Set the sweep time=span/3KHz.
- 3.The power spectral density was measured and recorded.
- 4.The Sweep time is allowed to be longer than span/3KHz for a full response of the mixer in the spectrum analyzer.

9.3 Test Setup Layout :

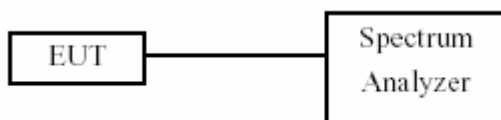

9.4 List of Measuring Equipment Used

Instrument/Ancillary	Model No.	Manufacturer	Serial No.	Valid Date.
Spectrum Analyzer	FSP40	R&S	100047	2007/01/16

9.5 Test Result and Data

(1) Modulation Standard: IEEE 802.11b (11Mbps)

Test Date: Feb. 06, 2006 Temperature: 22 Humidity: 70% Atmospheric pressure: 1026 mmHg

Channel	Frequency	Maximum Power Density of 3 kHz Bandwidth (dBm)
01	2412	-10.92
06	2437	-11.04
11	2462	-11.25

(2) Modulation Standard: IEEE 802.11g (54Mbps)

Test Date: Feb. 06, 2006 Temperature: 22 Humidity: 70% Atmospheric pressure: 1026 mmHg

Channel	Frequency	Maximum Power Density of 3 kHz Bandwidth (dBm)
01	2412	-19.79
06	2437	-19.58
11	2462	-19.28

Modulation Standard: 802.11b (11Mbps)
Channel: 01

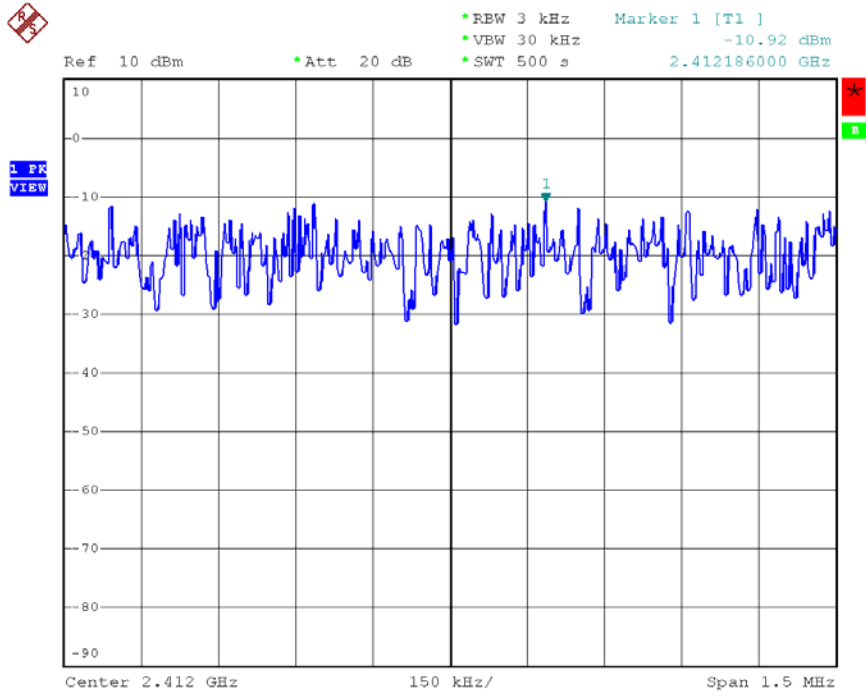

Date: 6.FEB.2006 13:46:31

Channel:06

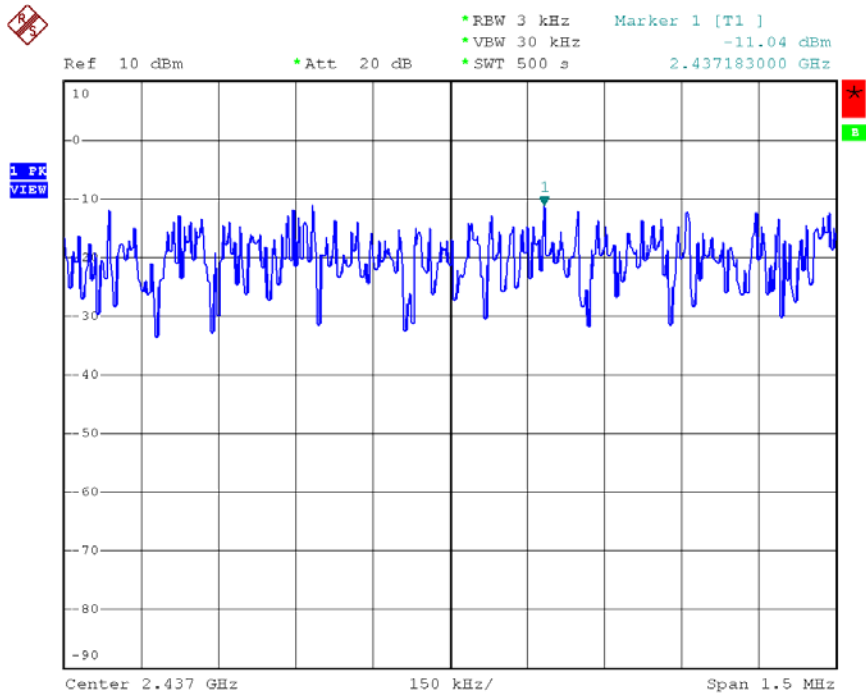

Date: 6.FEB.2006 13:58:49

Channel: 11

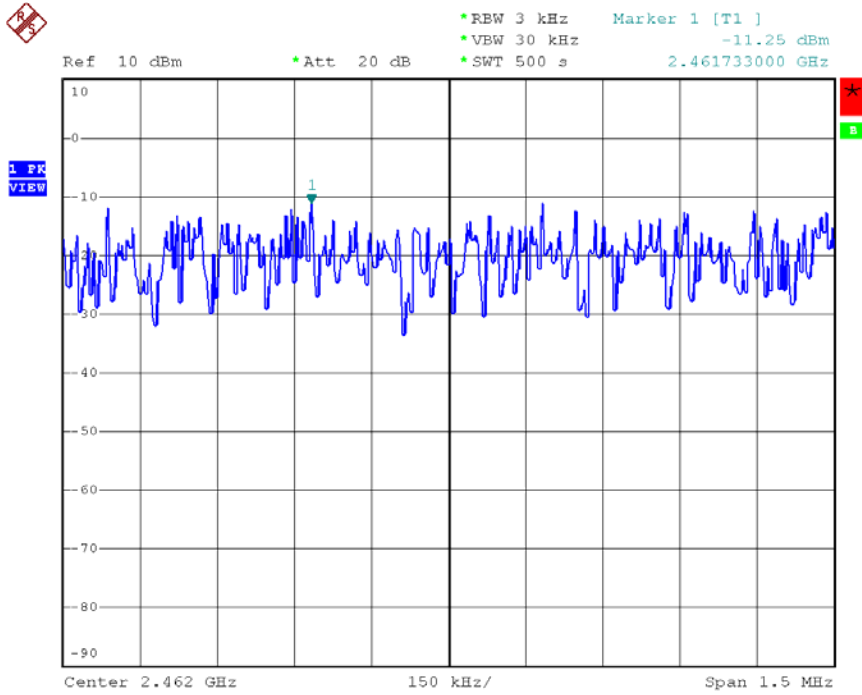

Date: 6.FEB.2006 14:03:26

Modulation Standard:802.11g (54Mbps)
Channel:01

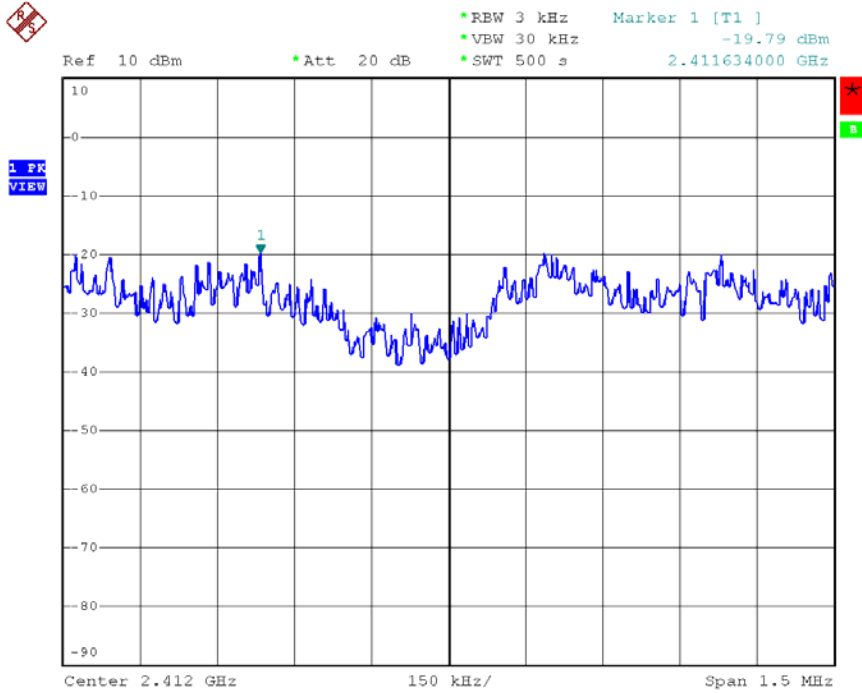

Date: 6.FEB.2006 14:05:12

Channel: 06

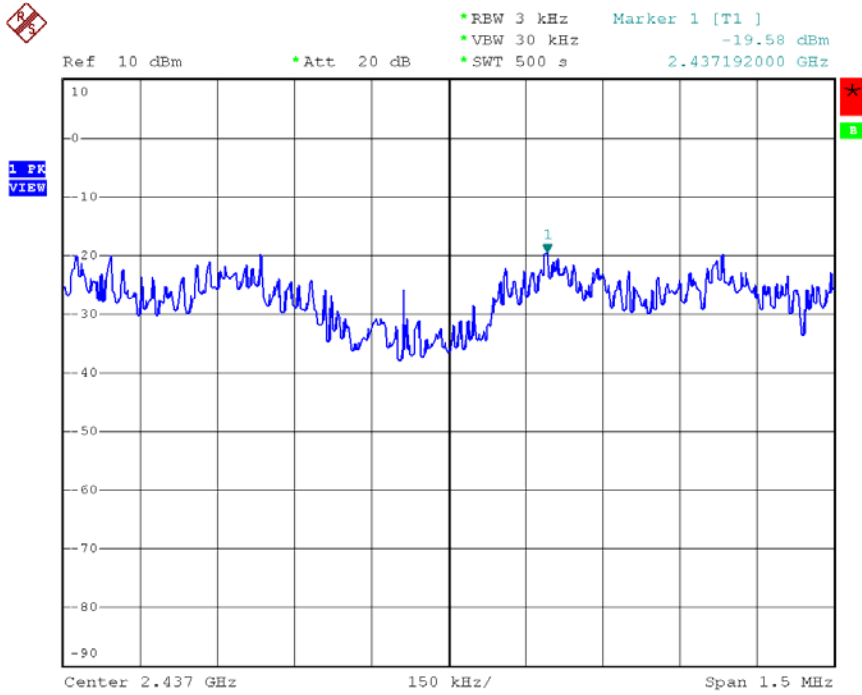

Date: 6.FEB.2006 14:06:50

Channel:11

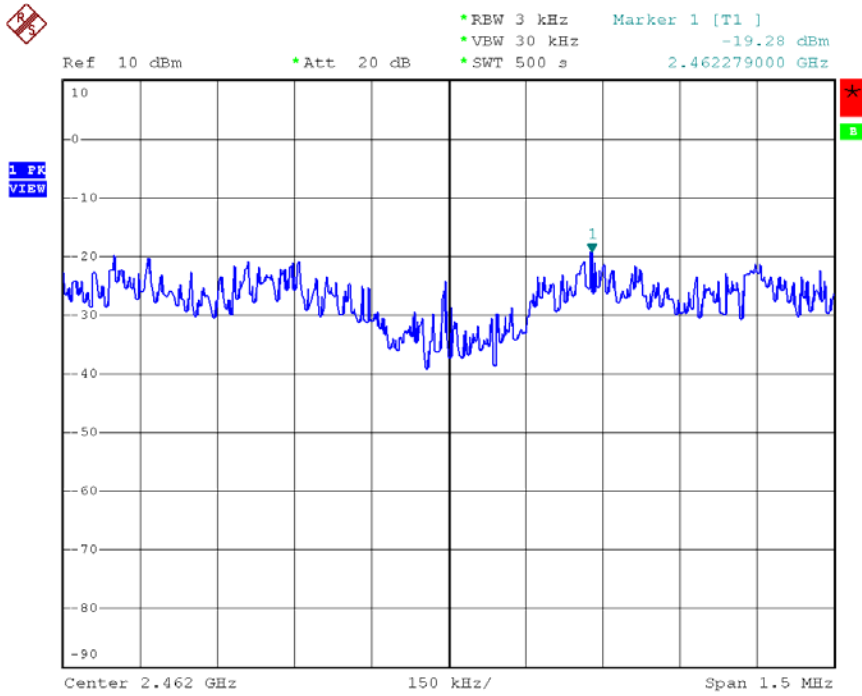

Date: 23.MAR.2006 17:33:07

10. Restricted Bands of Operation

Only spurious emissions are permitted in any of the frequency bands listed below:

MHz	MHz	MHz	GHz
0.09000 – 0.11000	16.42000 – 16.42300	399.9 – 410.0	4.500 – 5.250
0.49500 – 0.505**	16.69475 – 16.69525	608.0 – 614.0	5.350 – 5.460
2.17350 – 2.19050	16.80425 – 16.80475	960.0 – 1240.0	7.250 – 7.750
4.12500 – 4.12800	25.50000 – 25.67000	1300.0 – 1427.0	8.025 – 8.500
4.17725 – 4.17775	37.50000 – 38.25000	1435.0 – 1626.5	9.000 – 9.200
4.20725 – 4.20775	73.00000 – 74.60000	1645.5 – 1646.5	9.300 – 9.500
6.21500 – 6.21800	74.80000 – 75.20000	1660.0 – 1710.0	10.600 – 12.700
6.26775 – 6.26825	108.00000 – 121.94000	1718.8 – 1722.2	13.250 – 13.400
6.31175 – 6.31225	123.00000 – 138.00000	2200.0 – 2300.0	14.470 – 14.500
8.29100 – 8.29400	149.90000 – 150.05000	2310.0 – 2390.0	15.350 – 16.200
8.36200 – 8.36600	156.52475 – 156.52525	2483.5 – 2500.0	17.700 – 21.400
8.37625 – 8.38675	156.70000 – 156.90000	2655.0 – 2900.0	22.010 – 23.120
8.41425 – 8.41475	162.01250 – 167.17000	3260.0 – 3267.0	23.600 – 24.000
12.29000 – 12.29300	167.72000 – 173.20000	3332.0 – 3339.0	31.200 – 31.800
12.51975 – 12.52025	240.00000 – 285.00000	3345.8 – 3358.0	36.430 – 36.500
12.57675 – 12.57725	322.00000 – 335.40000	3600.0 – 4400.0	Above 38.6
13.36000 – 13.41000			

** : Until February 1, 1999, this restricted band shall be 0.490-0.510 MHz

10.1 Labeling Requirement

The device shall bear the following statement in a conspicuous location on the device:

This device complies with part 15 of the FCC Rules. Operation is subject to the following two conditions: (1) This device may not cause harmful interference, and (2) this device must accept any interference received, including interference that may cause undesired operation.