

FCC Test Report

(Part 24)

Report No.: RF190528D02

FCC ID: P27TP20213425

Test Model: INTTP20213425

Received Date: May 28, 2019

Test Date: Jul. 5 to 18, 2019

Issued Date: Jul. 19, 2019

Applicant: Sercomm Corp.

Address: 8F, No. 3-1, YuanQu St., NanKang, Taipei 115, Taiwan, R.O.C. (NanKang Software Park)

Issued By: Bureau Veritas Consumer Products Services (H.K.) Ltd., Taoyuan Branch

Lab Address: No. 47-2, 14th Ling, Chia Pau Vil., Lin Kou Dist., New Taipei City, Taiwan, R.O.C.

**FCC Registration /
Designation Number:** 198487 / TW2021



This report is for your exclusive use. Any copying or replication of this report to or for any other person or entity, or use of our name or trademark, is permitted only with our prior written permission. This report sets forth our findings solely with respect to the test samples identified herein. The results set forth in this report are not indicative or representative of the quality or characteristics of the lot from which a test sample was taken or any similar or identical product unless specifically and expressly noted. Our report includes all of the tests requested by you and the results thereof based upon the information that you provided to us. You have 60 days from date of issuance of this report to notify us of any material error or omission caused by our negligence, provided, however, that such notice shall be in writing and shall specifically address the issue you wish to raise. A failure to raise such issue within the prescribed time shall constitute your unqualified acceptance of the completeness of this report, the tests conducted and the correctness of the report contents. Unless specific mention, the uncertainty of measurement has been explicitly taken into account to declare the compliance or non-compliance to the specification. The report must not be used by the client to claim product certification, approval, or endorsement by TAF or any government agencies.

Table of Contents

Release Control Record	4
1 Certificate of Conformity	5
2 Summary of Test Results	6
2.1 Measurement Uncertainty.....	6
2.2 Test Site and Instruments.....	7
3 General Information	8
3.1 General Description of EUT.....	8
3.2 Configuration of System Under Test.....	9
3.2.1 Description of Support Units.....	9
3.3 Test Mode Applicability and Tested Channel Detail.....	10
3.4 EUT Operating Conditions.....	11
3.5 General Description of Applied Standards.....	11
4 Test Types and Results	12
4.1 Output Power Measurement.....	12
4.1.1 Limits of Output Power Measurement.....	12
4.1.2 Test Procedures.....	12
4.1.3 Test Setup.....	13
4.1.4 Test Results.....	14
4.2 Modulation Characteristics Measurement.....	16
4.2.1 Limits of Modulation characteristics.....	16
4.2.2 Test Procedure.....	16
4.2.3 Test Setup.....	16
4.2.4 Test Results.....	16
4.3 Frequency Stability Measurement.....	17
4.3.1 Limits of Frequency Stability Measurement.....	17
4.3.2 Test Procedure.....	17
4.3.3 Test Setup.....	17
4.3.4 Test Results.....	18
4.4 Occupied Bandwidth Measurement.....	19
4.4.1 Test Procedure.....	19
4.4.2 Test Setup.....	19
4.4.3 Test Result.....	20
4.5 Band Edge Measurement.....	22
4.5.1 Limits of Band Edge Measurement.....	22
4.5.2 Test Setup.....	22
4.5.3 Test Procedures.....	22
4.5.4 Test Results.....	23
4.6 Peak To Average Ratio.....	25
4.6.1 Limits of Peak To Average Ratio Measurement.....	25
4.6.2 Test Setup.....	25
4.6.3 Test Procedures.....	25
4.6.4 Test Results.....	26
4.7 Conducted Spurious Emissions.....	27
4.7.1 Limits of Conducted Spurious Emissions Measurement.....	27
4.7.2 Test Setup.....	27
4.7.3 Test Procedure.....	27
4.7.4 Test Results.....	28
4.8 Radiated Emission Measurement.....	34
4.8.1 Limits of Radiated Emission Measurement.....	34
4.8.2 Test Procedure.....	34
4.8.3 Deviation from Test Standard.....	34
4.8.4 Test Setup.....	35

4.8.5 Test Results	36
5 Pictures of Test Arrangements	40
Appendix – Information of the Testing Laboratories	41

Release Control Record

Issue No.	Description	Date Issued
RF190528D02	Original release.	Jul. 19, 2019

1 Certificate of Conformity

Product: Verizon LTE

Brand: Verizon

Test Model: INTTP20213425

Sample Status: Engineering sample

Applicant: Sercomm Corp.

Test Date: Jul. 5 to 18, 2019

Standards: FCC Part 24, Subpart E

The above equipment has been tested by **Bureau Veritas Consumer Products Services (H.K.) Ltd., Taoyuan Branch**, and found compliance with the requirement of the above standards. The test record, data evaluation & Equipment Under Test (EUT) configurations represented herein are true and accurate accounts of the measurements of the sample's RF characteristics under the conditions specified in this report.

Prepared by :



, Date: Jul. 19, 2019

Celia Chen / Supervisor

Approved by :



, Date: Jul. 19, 2019

Rex Lai / Associate Technical Manager

2 Summary of Test Results

Applied Standard: FCC Part 24 & Part 2			
FCC Clause	Test Item	Result	Remarks
2.1046 24.232	Equivalent Isotropically Radiated Power	Pass	Meet the requirement of limit.
2.1047	Modulation characteristics	Pass	Meet the requirement.
2.1046 24.232(d)	Peak To Average Ratio	Pass	Meet the requirement of limit.
2.1055 24.235	Frequency Stability	Pass	Meet the requirement of limit.
2.1049 24.238(b)	Occupied Bandwidth	Pass	Meet the requirement of limit.
24.238(a)	Band Edge Measurements	Pass	Meet the requirement of limit.
2.1051 24.238	Conducted Spurious Emissions	Pass	Meet the requirement of limit.
2.1053 24.238	Radiated Spurious Emissions	Pass	Meet the requirement of limit. Minimum passing margin is -26.72 dB at 3872.06MHz.

Note: Determining compliance based on the results of the compliance measurement, not taking into account measurement instrumentation uncertainty.

2.1 Measurement Uncertainty

Where relevant, the following measurement uncertainty levels have been estimated for tests performed on the EUT as specified in CISPR 16-4-2:

Measurement	Frequency	Expanded Uncertainty (k=2) (\pm)
Radiated Emissions up to 1 GHz	30MHz ~ 1000MHz	5.43 dB
Radiated Emissions above 1 GHz	1GHz ~ 40GHz	5.42 dB

2.2 Test Site and Instruments

DESCRIPTION & MANUFACTURER	MODEL NO.	SERIAL NO.	CALIBRATED DATE	CALIBRATED UNTIL
HP Preamplifier	8447D	2432A03504	Feb. 20, 2019	Feb. 19, 2020
HP Preamplifier	8449B	3008A01201	Feb. 21, 2019	Feb. 20, 2020
MITEQ Preamplifier	AMF-6F-260400-33-8P	892164	Feb. 20, 2019	Feb. 19, 2020
Agilent TEST RECEIVER	N9038A	MY51210129	Mar. 05, 2019	Mar. 04, 2020
Schwarzbeck Antenna	VULB 9168	139	Nov. 26, 2018	Nov. 25, 2019
Schwarzbeck Antenna	VHBA 9123	480	Jun. 3, 2019	Jun. 2, 2021
Schwarzbeck Horn Antenna	BBHA-9170	212	Nov. 25, 2018	Nov. 24, 2019
Schwarzbeck Horn Antenna	BBHA 9120-D1	D130	Nov. 25, 2018	Nov. 24, 2019
ADT. Turn Table	TT100	0306	NA	NA
ADT. Tower	AT100	0306	NA	NA
Software	Radiated_V7.6.15.9.5	NA	NA	NA
SUHNER RF cable With 4dB PAD	SF102	Cable-CH6-01	Aug. 13, 2018	Aug. 12, 2019
SUHNER RF cable With 3/4dB PAD	SF102	Cable-CH8-3.6m	Aug. 13, 2018	Aug. 12, 2019
KEYSIGHT MIMO Powermeasurement Test set	U2021XA	U2021XA-001	Jun. 11, 2019	Jun. 10, 2020
KEYSIGHT Spectrum Analyzer	N9030A	MY54490260	Aug. 3, 2018	Aug. 2, 2019
Loop Antenna EMCI	LPA600	270	Aug. 11, 2017	Aug. 10, 2019
EMCO Horn Antenna	3115	00028257	Nov. 25, 2018	Nov. 24, 2019
Highpass filter Wainwright Instruments	WHK 3.1/18G-10SS	SN 8	NA	NA
ROHDE & SCHWARZ Spectrum Analyzer	FSV40	101042	Sep. 27, 2018	Sep. 26, 2019
Anritsu Power Sensor	MA2411B	0738404	Apr. 16, 2019	Apr. 15, 2020
Anritsu Power Meter	ML2495A	0842014	Apr. 16, 2019	Apr. 15, 2020
Temperature & Humidity Chamber	MHU-225AU	920409	May 24, 2019	May 23, 2020
DIGITAL POWER METER IDRC	CP-240	240515	Sep. 13, 2018	Sep. 12, 2019
AC Power Source ExTech	CFW-105	E000603	NA	NA

- NOTE:**
1. The calibration interval of the above test instruments is 12/24 months. And the calibrations are traceable to NML/ROC and NIST/USA.
 2. The horn antenna and HP preamplifier (model: 8449B) are used only for the measurement of emission frequency above 1GHz if tested.
 3. The test was performed in Chamber No. 6.

3 General Information

3.1 General Description of EUT

Product	Verizon LTE	
Brand	Verizon	
Test Model	INTTP20213425	
Status of EUT	Engineering sample	
Power Supply Rating	12Vdc (adapter)	
Modulation Type	QPSK, 16QAM, 64QAM	
Operating Frequency	LTE Band 2 (Channel Bandwidth 10MHz)	1935MHz ~ 1985MHz
	LTE Band 2 (Channel Bandwidth 20MHz)	1940MHz ~ 1980MHz
Max. EIRP Power	LTE Band 2 (Channel Bandwidth 10MHz)	466.659mW (26.69dBm)
	LTE Band 2 (Channel Bandwidth 20MHz)	451.856mW (26.55dBm)
Antenna Type	LTE Band 2	Dipole antenna with 2.5dBi gain
Antenna Connector	RP-SMA	
Accessory Device	Adapter	
Data Cable Supplied	Non-shielded GPS Antenna (9m)*2	

Note:

1. The EUT uses following adapter.

Brand	PHIHONG
Model	PSA120U-120L6
Input Power	100-240Vac, 1.6A, 50-60Hz
Output Power	12Vdc, 9A
Power Line	Non-shielded AC 3 Pin (1.8m)
	Non-shielded DC cable (1.5m) with one ferrite core

2. The above EUT information is declared by manufacturer and for more detailed features description, please refers to the manufacturer's specifications or user's manual.

3.2 Configuration of System Under Test

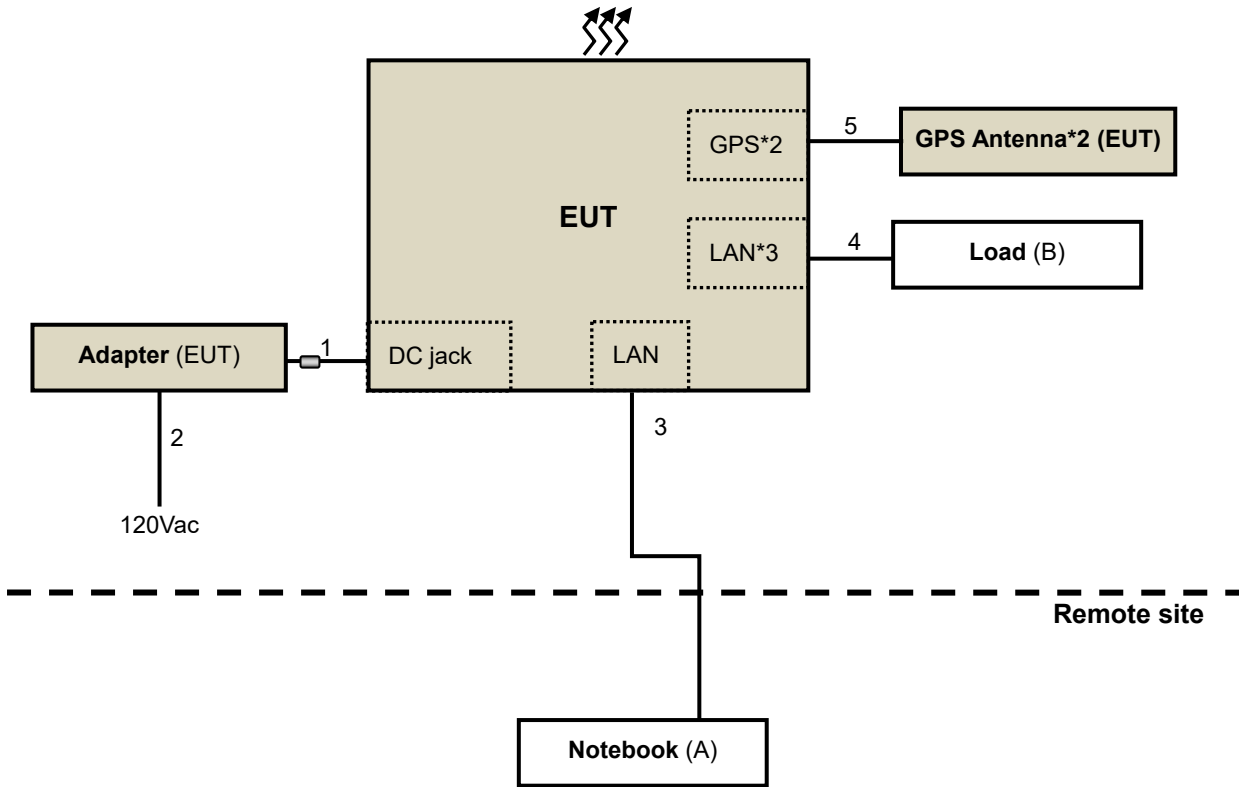

3.2.1 Description of Support Units

The EUT has been tested as an independent unit together with other necessary accessories or support units. The following support units or accessories were used to form a representative test configuration during the tests.

ID	Product	Brand	Model No.	Serial No.	FCC ID	Remarks
A.	Notebook	DELL	E5410	BW33YM1	N/A	Provided by Lab
B.	Load	N/A	N/A	N/A	N/A	Provided by Lab

Note:

1. All power cords of the above support units are non-shielded (1.8m).
2. Item A acted as communication partners to transfer data.

ID	Descriptions	Qty.	Length (m)	Shielding (Yes/No)	Cores (Qty.)	Remarks
1.	DC cable	1	1.5	N	1	Supplied by client
2.	AC power cord	1	1.8	N	0	Supplied by client
3.	LAN cable	1	10.0	N	0	Provided by Lab
4.	LAN cable	3	1.0	N	0	Provided by Lab
5.	GPS Antenna	2	9	N	0	Supplied by client

3.3 Test Mode Applicability and Tested Channel Detail

LTE Band 2

Test item	Available channel	Tested channel	Channel Bandwidth	Modulation
EIRP	650 to 1150	650, 900, 1150	10MHz	QPSK, 16QAM, 64QAM
	700 to 1100	700, 900, 1100	20MHz	QPSK, 16QAM, 64QAM
Modulation characteristics	650 to 1150	900	10MHz	QPSK, 16QAM, 64QAM
Frequency Stability	650 to 1150	900	10MHz	QPSK
Occupied Bandwidth	650 to 1150	650, 900, 1150	10MHz	QPSK, 16QAM, 64QAM
	700 to 1100	700, 900, 1100	20MHz	QPSK, 16QAM, 64QAM
Band Edge	650 to 1150	650, 1150	10MHz	QPSK
	700 to 1100	700, 1100	20MHz	QPSK
Peak to Average Ratio	650 to 1150	650, 900, 1150	10MHz	QPSK, 16QAM, 64QAM
	700 to 1100	700, 900, 1100	20MHz	QPSK, 16QAM, 64QAM
Conducuted Emission	650 to 1150	650, 900, 1150	10MHz	QPSK
	700 to 1100	700, 900, 1100	20MHz	QPSK
Radiated Emission Below 1GHz	650 to 1150	650	10MHz	QPSK
	700 to 1100	700	20MHz	QPSK
Radiated Emission Above 1GHz	650 to 1150	650, 900, 1150	10MHz	QPSK
	700 to 1100	700, 900, 1100	20MHz	QPSK

NOTE:

1. For radiated emission below 1 GHz, the low, mid and high channels were pre-tested in chamber. The low channel was the worst case and chosen for final test.
2. The conducted output power for QPSK /16QAM / 64QAM, measured value of QPSK is higher than 16QAM / 64QAM mode. Therefore, the Frequency Stability, Band Edge, Conducuted Emission and Radiated Emission were performed under QPSK mode only.

Test Condition:

Test Item	Environmental Conditions	Input Power	Tested By
EIRP	30deg. C, 83%RH	120Vac, 60Hz	Ian Chang
Modulation characteristics	20deg. C, 76%RH	120Vac, 60Hz	Saxon Lee
Frequency Stability	20deg. C, 76%RH	120Vac, 60Hz	Saxon Lee
Occupied Bandwidth	20deg. C, 76%RH	120Vac, 60Hz	Saxon Lee
Band Edge	20deg. C, 76%RH	120Vac, 60Hz	Saxon Lee
Peak To Average Ratio	20deg. C, 76%RH	120Vac, 60Hz	Saxon Lee
Conducted Emission	20deg. C, 73%RH	120Vac, 60Hz	Saxon Lee
Radiated Emission	32deg. C, 61%RH	120Vac, 60Hz	Ian Chang

3.4 EUT Operating Conditions

The EUT makes a call to the communication simulator. The communication simulator station system controlled a EUT to export maximum output power under transmission mode and specific channel frequency

3.5 General Description of Applied Standards

The EUT is a RF Product. According to the specifications of the manufacturer, it must comply with the requirements of the following standards:

FCC 47 CFR Part 2

FCC 47 CFR Part 24

KDB 971168 D01 Power Meas License Digital Systems v02r02

KDB 662911 D01 Multiple Transmitter Output v02r01

ANSI/TIA/EIA-603-E 2016

ANSI 63.26-2015

Note: All test items have been performed and recorded as per the above standards.

4 Test Types and Results

4.1 Output Power Measurement

4.1.1 Limits of Output Power Measurement

For Band 2: The equivalent isotropically radiated power shall be according to the specific rule Part 24.232(a)(1).

4.1.2 Test Procedures

EIRP / ERP Measurement:

- a. All measurements were done at low, middle and high operational frequency range. RBW and VBW is 10MHz for LTE Mode.
- b. Substitution method is used for E.I.R.P measurement. In the semi-anechoic chamber, EUT placed on the 0.8m(below or equal 1GHz) and/or 1.5m(above 1GHz) height of Turn Table, rotated the table around 360 degrees to search the maximum radiation power and receiver antenna shall be rotated vertical and horizontal polarization and moved height from 1m to 4m to find the maximum polar radiated power. The "Read Value" is the spectrum reading the maximum power value.
- c. The substitution horn antenna is substituted for EUT at the same position and signals generator export the CW signal to the substitution antenna via a tx cable. Rotated the Turn Table and moved receiving antenna to find the maximum radiation power. Adjust output power level of S.G to get a Value of spectrum reading equal to "Read Value" of step b. Record the power level of S.G
- d. $EIRP = \text{Output power level of S.G} - \text{TX cable loss} + \text{Antenna gain of substitution horn}$. E.R.P power can be calculated form E.I.R.P power by subtracting the gain of dipole, $E.R.P \text{ power} = E.I.R.P \text{ power} - 2.15\text{dBi}$.

Conducted Power Measurement:

A power sensor was used on the output port of the EUT. A power meter was used to read the response of the power sensor. Record the power level.

4.1.3 Test Setup

**EIRP / ERP Measurement:
For Radiated Emission below or equal 1GHz**

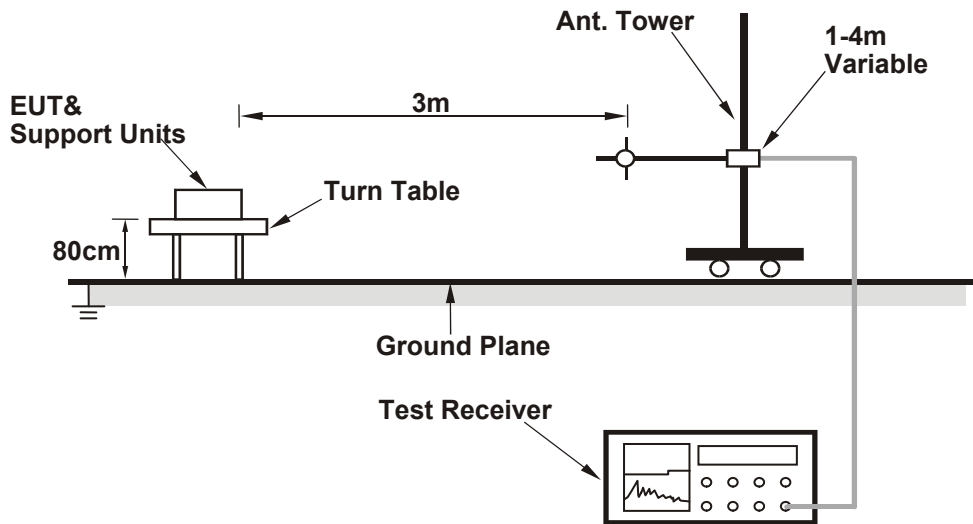

For Radiated Emission above 1GHz

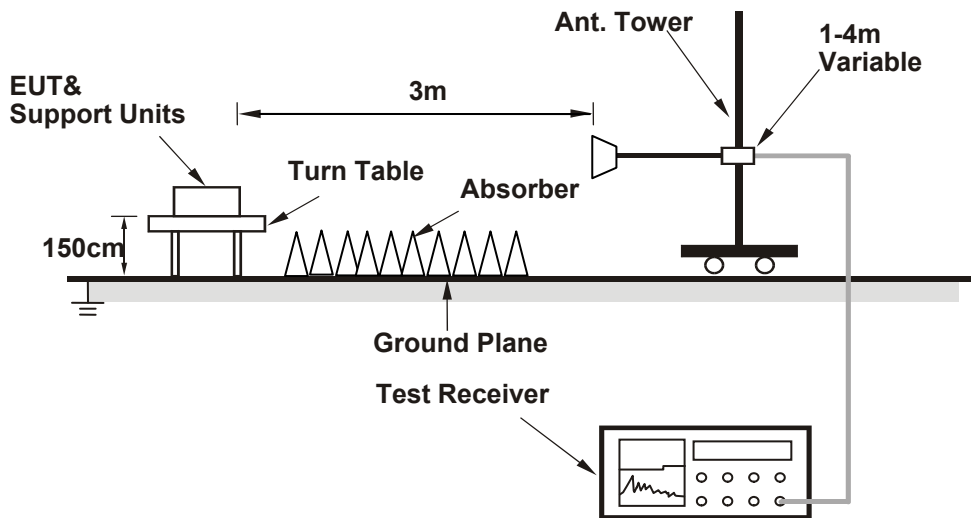

For the actual test configuration, please refer to the attached file (Test Setup Photo).

Conducted Power Measurement:

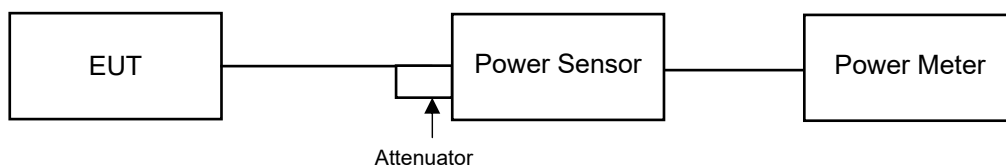

For the actual test configuration, please refer to the attached file (Test Setup Photo).

4.1.4 Test Results

Conducted Output Power (dBm)

LTE Band 2 (Channel Bandwidth 10MHz)

CH	Frequency (MHz)	CONDUCTED OUTPUT POWER (dBm)								
		QPSK			16QAM			64QAM		
		Chain 0	Chain 1	Total	Chain 0	Chain 1	Total	Chain 0	Chain 1	Total
650	1935	17.18	17.32	20.26	17.11	17.26	20.20	17.06	17.16	20.12
900	1960	17.12	17.26	20.20	17.02	17.19	20.12	17.00	17.08	20.05
1150	1985	17.10	17.25	20.19	17.06	17.22	20.15	17.02	17.15	20.10

LTE Band 2 (Channel Bandwidth 20MHz)

CH	Frequency (MHz)	CONDUCTED OUTPUT POWER (dBm)								
		QPSK			16QAM			64QAM		
		Chain 0	Chain 1	Total	Chain 0	Chain 1	Total	Chain 0	Chain 1	Total
700	1940	17.15	17.31	20.24	17.09	17.28	20.20	17.06	17.25	20.17
900	1960	17.11	17.26	20.20	17.06	17.22	20.15	17.02	17.18	20.11
1100	1980	17.10	17.28	20.20	17.10	17.23	20.18	17.03	17.16	20.11

EIRP Power (dBm)
LTE Band 2 (Channel Bandwidth: 10MHz)

Modulation Type: QPSK					
Channel	Frequency (MHz)	Reading (dBm)	S.G Power Value (dBm)	Correction Factor (dB)	EIRP (dBm)
650	1935.00	-15.58	18.96	7.73	26.69
900	1960.00	-15.80	18.78	7.70	26.48
1150	1985.00	-15.72	18.91	7.66	26.57
Modulation Type: 16QAM					
Channel	Frequency (MHz)	Reading (dBm)	S.G Power Value (dBm)	Correction Factor (dB)	EIRP (dBm)
650	1935.00	-15.73	18.81	7.73	26.54
900	1960.00	-15.85	18.73	7.70	26.43
1150	1985.00	-16.17	18.46	7.66	26.12
Modulation Type: 64QAM					
Channel	Frequency (MHz)	Reading (dBm)	S.G Power Value (dBm)	Correction Factor (dB)	EIRP (dBm)
650	1935.00	-15.80	18.74	7.73	26.47
900	1960.00	-15.97	18.61	7.70	26.31
1150	1985.00	-16.33	18.30	7.66	25.96

Note: EIRP (dBm) = S.G Power Value (dBm) + Correction Factor (dB).

LTE Band 2 (Channel Bandwidth 20MHz):

Modulation Type: QPSK					
Channel	Frequency (MHz)	Reading (dBm)	S.G Power Value (dBm)	Correction Factor (dB)	EIRP (dBm)
700	1940.00	-15.72	18.82	7.73	26.55
900	1960.00	-15.75	18.83	7.70	26.53
1100	1980.00	-15.92	18.69	7.67	26.36
Modulation Type: 16QAM					
Channel	Frequency (MHz)	Reading (dBm)	S.G Power Value (dBm)	Correction Factor (dB)	EIRP (dBm)
700	1940.00	-15.73	18.81	7.73	26.54
900	1960.00	-15.76	18.82	7.70	26.52
1100	1980.00	-16.09	18.52	7.67	26.19
Modulation Type: 64QAM					
Channel	Frequency (MHz)	Reading (dBm)	S.G Power Value (dBm)	Correction Factor (dB)	EIRP (dBm)
700	1940.00	-15.77	18.77	7.73	26.50
900	1960.00	-15.92	18.66	7.70	26.36
1100	1980.00	-16.24	18.37	7.67	26.04

Note: EIRP (dBm) = S.G Power Value (dBm) + Correction Factor (dB).

4.2 Modulation Characteristics Measurement

4.2.1 Limits of Modulation characteristics

N/A

4.2.2 Test Procedure

Connect the EUT to Communication Simulator via the antenna connector. The frequency band is set as EUT supported Modulation and Channels, the EUT output is matched with 50 ohm load, the waveform quality and constellation of the EUT was tested.

4.2.3 Test Setup



4.2.4 Test Results

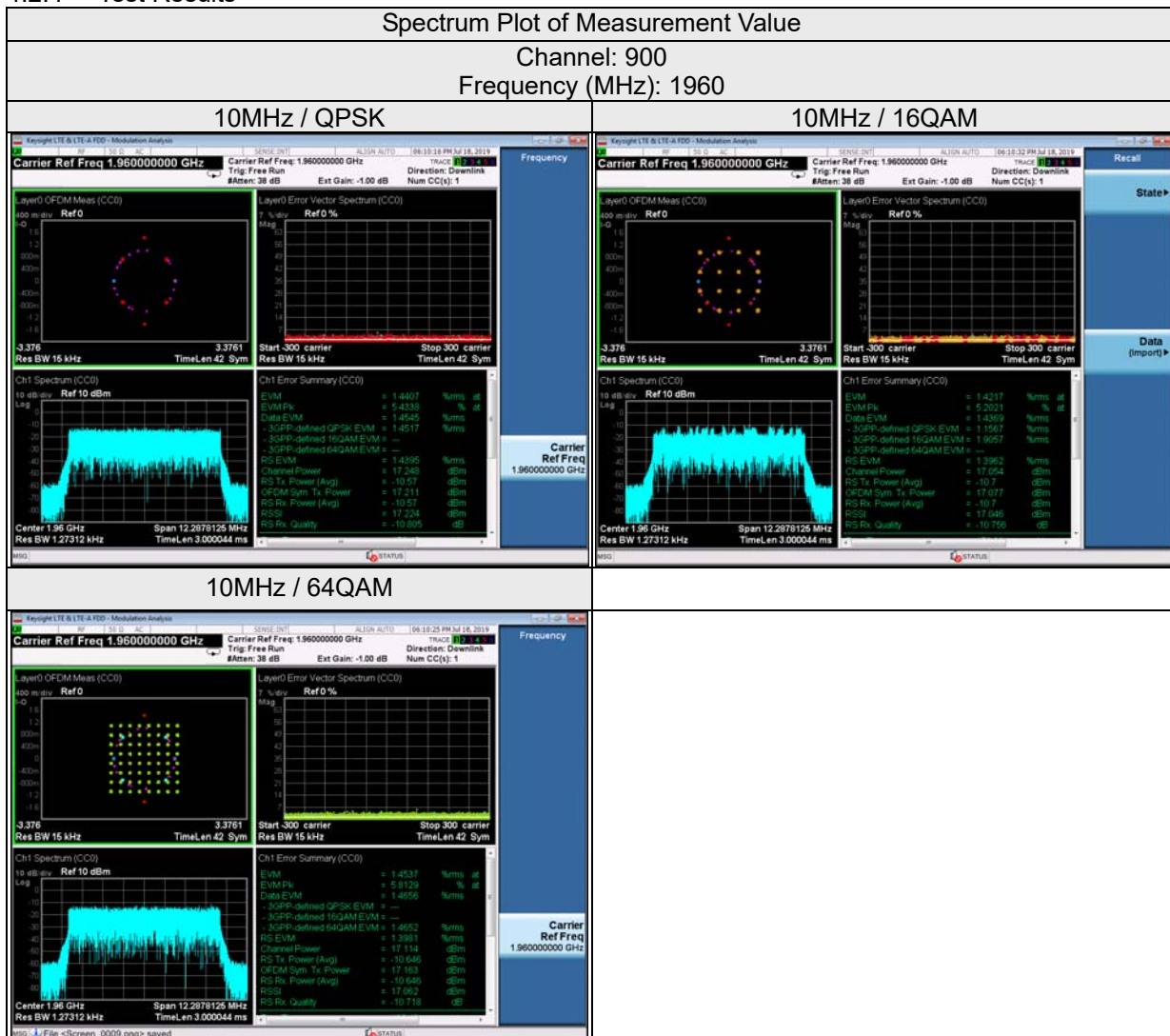

4.3 Frequency Stability Measurement

4.3.1 Limits of Frequency Stability Measurement

The frequency stability shall be sufficient to ensure that the fundamental emission stays within the authorized frequency block.

4.3.2 Test Procedure

- Device is placed at the oven room. The oven room could control the temperatures and humidity. Power warm up is at least 15 min and power applied should perform before recording frequency error.
- EUT is connected the external power supply to control the AC input power. The test voltage range is from minimum to maximum working voltage. Each step shall be record the frequency error rate.
- The temperature range step is 10 degrees in this test items. All temperature levels shall be hold the $\pm 0.5^{\circ}\text{C}$ during the measurement testing. The each temperature step shall be at least 0.5 hours, consider the EUT could be test under the stability condition.

4.3.3 Test Setup

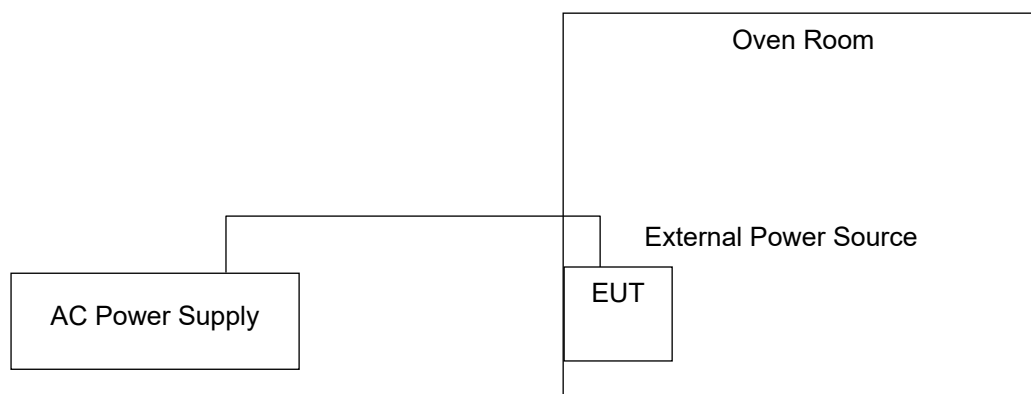

4.3.4 Test Results

Frequency Error vs. Voltage

Voltage (Volts)	Frequency Error (ppm)
	LTE Band 2
132	0.0056122449
120	0.0051020408
108	0.0045918367

Note: The applicant defined the normal working voltage is from 132Vac to 108Vac.

Frequency Error vs. Temperature

Temp. (°C)	Frequency Error (ppm)
	LTE Band 2
75	0.0061224490
70	0.0056122449
60	0.0051020408
50	0.0051020408
40	0.0045918367
30	0.0045918367
20	0.0040816327
10	0.0040816327
0	0.0035714286
-10	0.0035714286
-20	0.0025510204
-30	0.0025510204

4.4 Occupied Bandwidth Measurement

4.4.1 Test Procedure

The EUT makes a call to the communication simulator. All measurements were done at low, middle and high operational frequency range. The communication simulator station system controlled a EUT to export maximum output power under transmission mode and specific channel frequency. Use OBW measurement function of Spectrum analyzer to measure 99 % occupied bandwidth.

4.4.2 Test Setup

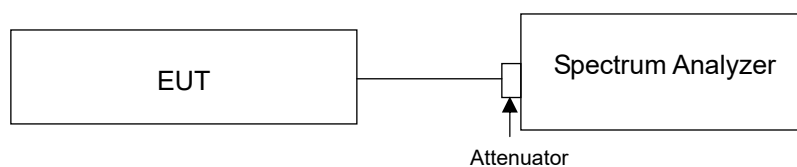

4.4.3 Test Result

LTE Band 2							
Channel Bandwidth 10MHz							
Channel	Frequency (MHz)	99% Occupied Bandwidth (MHz)					
		QPSK		16QAM		64QAM	
		Chain 0	Chain 1	Chain 0	Chain 1	Chain 0	Chain 1
650	1935	8.97	8.97	8.99	8.98	8.96	8.98
900	1960	8.97	8.97	8.99	8.99	8.97	8.98
1150	1985	8.98	8.98	9.00	9.00	8.98	8.98
Channel Bandwidth 20MHz							
Channel	Frequency (MHz)	99% Occupied Bandwidth (MHz)					
		QPSK		16QAM		64QAM	
		Chain 0	Chain 1	Chain 0	Chain 1	Chain 0	Chain 1
700	1940	17.97	17.97	18.01	18.01	17.98	17.99
900	1960	17.96	17.96	18.00	17.99	17.98	17.97
1100	1980	17.95	17.95	17.99	17.99	17.97	17.98

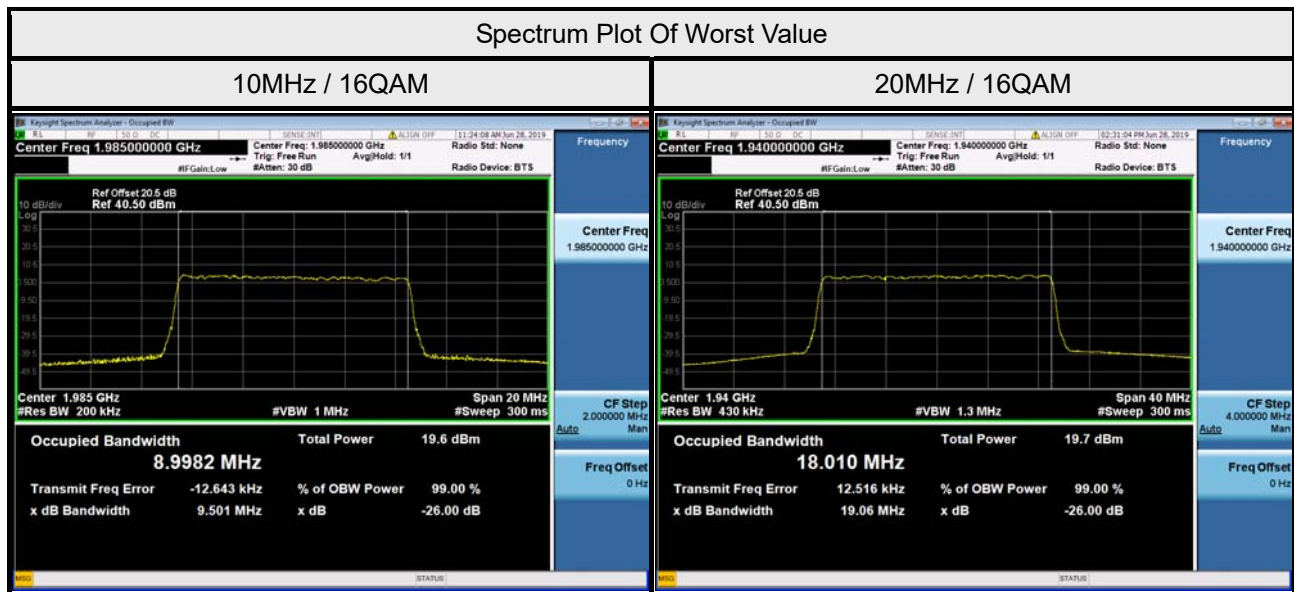

LTE Band 2							
Channel Bandwidth 10MHz							
Channel	Frequency (MHz)	-26dBc Bandwidth (MHz)					
		QPSK		16QAM		64QAM	
		Chain 0	Chain 1	Chain 0	Chain 1	Chain 0	Chain 1
650	1935	9.52	9.57	9.51	9.52	9.55	9.50
900	1960	9.54	9.56	9.49	9.52	9.55	9.49
1150	1985	9.54	9.53	9.52	9.50	9.56	9.49
Channel Bandwidth 20MHz							
Channel	Frequency (MHz)	-26dBc Bandwidth (MHz)					
		QPSK		16QAM		64QAM	
		Chain 0	Chain 1	Chain 0	Chain 1	Chain 0	Chain 1
700	1940	19.13	19.14	19.06	19.07	19.10	19.05
900	1960	19.14	19.14	19.07	19.06	19.05	19.05
1100	1980	19.11	19.09	19.04	19.04	19.00	19.03

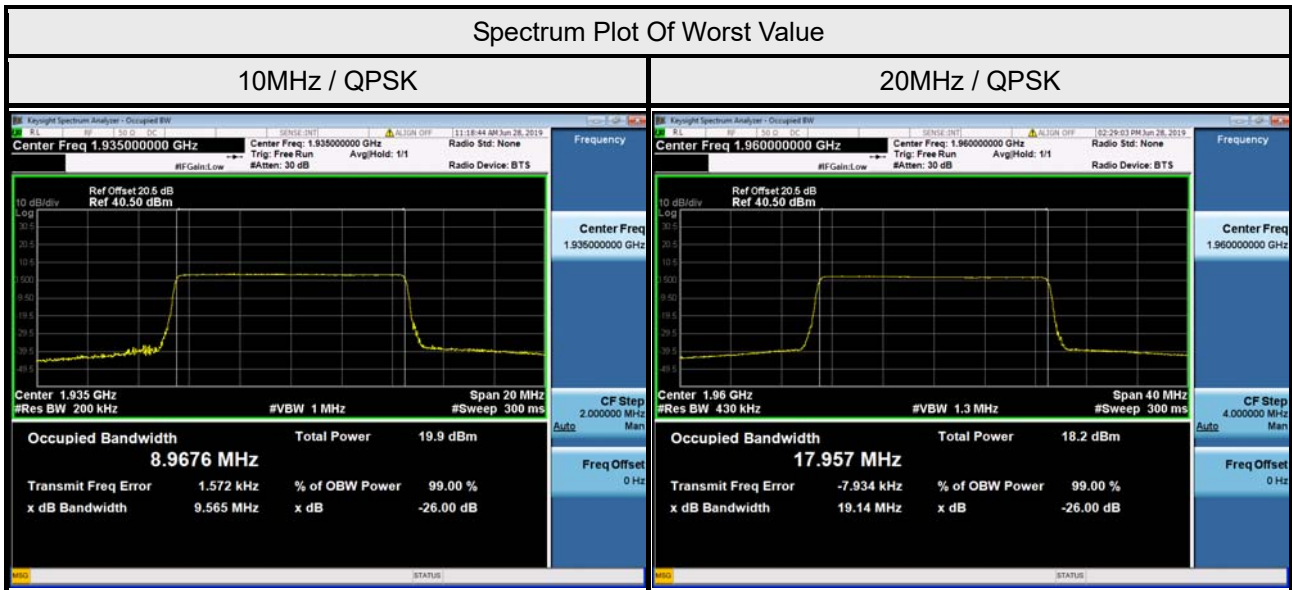

4.5 Band Edge Measurement

4.5.1 Limits of Band Edge Measurement

Power of any emission outside of the authorized operating frequency ranges must be attenuated below the transmitting power (P) by a factor of at least $43 + 10 \log(P)$ dB. In the 1 MHz bands immediately outside and adjacent to the frequency block a resolution bandwidth of at least one percent of the emission bandwidth of the fundamental emission of the transmitter may be employed.

Note: The results for each of the transmit chains shall be individually compared with the limits after these limits have been reduced by $10 \times \log(N)$ (number of active transmit chains).

4.5.2 Test Setup

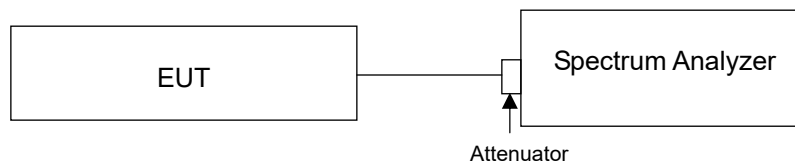

4.5.3 Test Procedures

- a. All measurements were done at low and high operational frequency range.
- b. The center frequency of spectrum is the band edge frequency and span is 200kHz. RB of the spectrum is 200kHz and VB of the spectrum is 620kHz (LTE Channel Bandwidth 10MHz).
- c. The center frequency of spectrum is the band edge frequency and span is 400kHz. RB of the spectrum is 430kHz and VB of the spectrum is 1300kHz (LTE Channel Bandwidth 20MHz).
- d. Record the max trace plot into the test report.

4.5.4 Test Results

LTE Band 2

Channel Bandwidth 10MHz

Chain 0

Channel 650

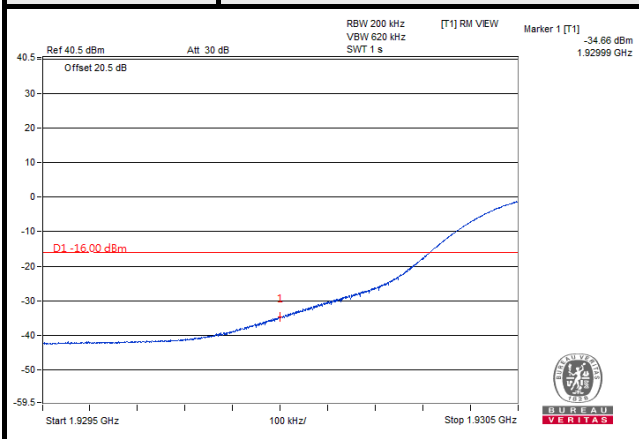

Channel 1150

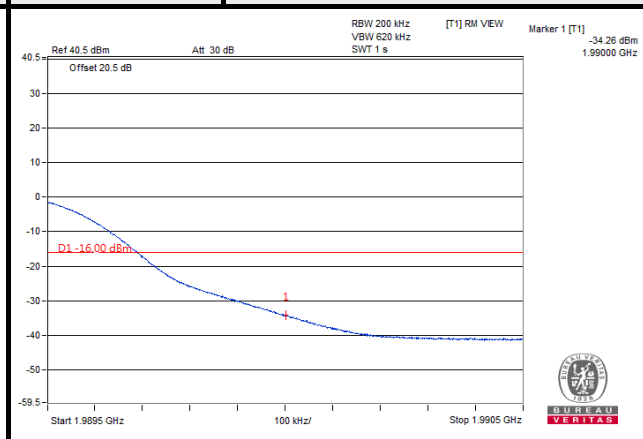

Chain 1

Channel 650

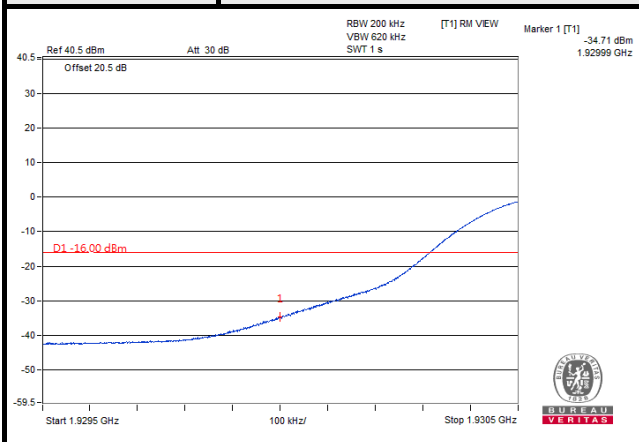

Channel 1150

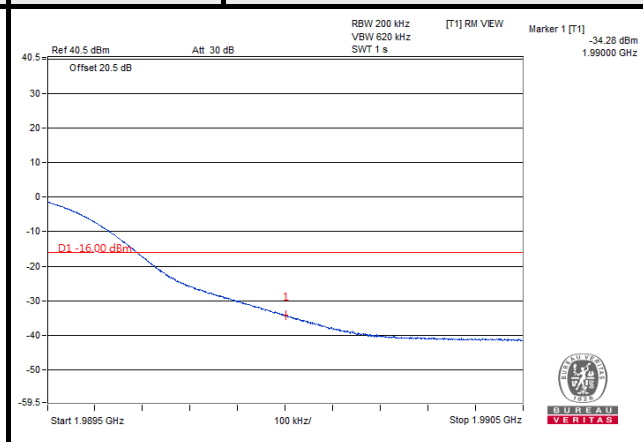

LTE Band 2

Channel Bandwidth 20MHz

Chain 0

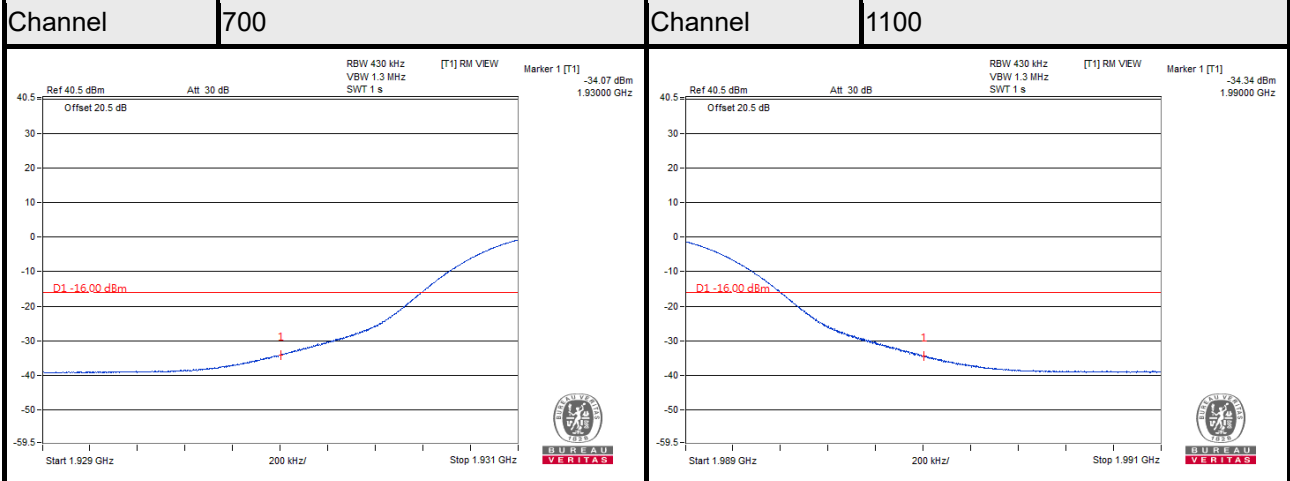

Chain 1

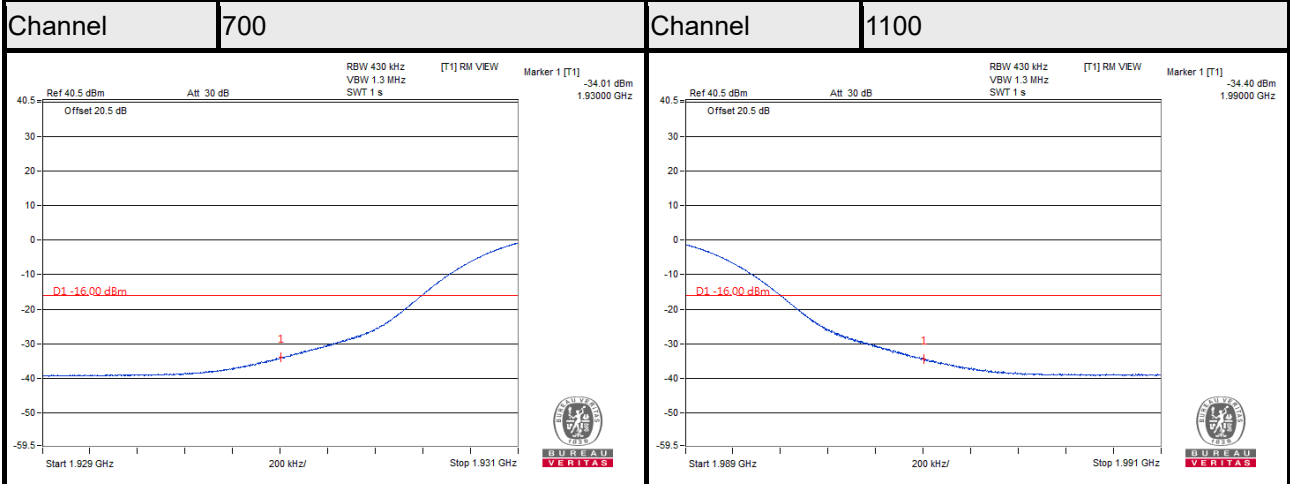

4.6 Peak To Average Ratio

4.6.1 Limits of Peak To Average Ratio Measurement

In measuring transmissions in this band using an average power technique, the peak to-average ratio (PAR) of the transmission may not exceed 13 dB

4.6.2 Test Setup

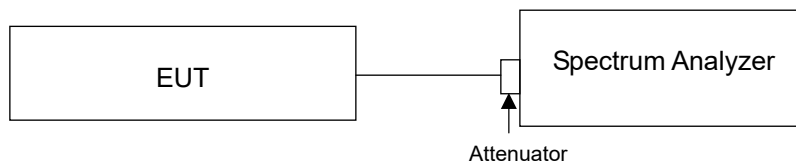

4.6.3 Test Procedures

- a. Set resolution/measurement bandwidth \geq signal's occupied bandwidth;
- b. Set the number of counts to a value that stabilizes the measured CCDF curve;
- c. Record the maximum PAPR level associated with a probability of 0.1%.

4.6.4 Test Results

LTE Band 2							
Channel Bandwidth 10MHz							
Channel	Frequency (MHz)	Peak To Average Ratio (dB)					
		QPSK		16QAM		64QAM	
		Chain 0	Chain 1	Chain 0	Chain 1	Chain 0	Chain 1
650	1935	8.43	8.40	8.39	8.35	8.35	8.33
900	1960	8.39	8.42	8.32	8.41	8.37	8.36
1150	1985	8.43	8.47	8.31	8.42	8.36	8.39
Channel Bandwidth 20MHz							
Channel	Frequency (MHz)	Peak To Average Ratio (dB)					
		QPSK		16QAM		64QAM	
		Chain 0	Chain 1	Chain 0	Chain 1	Chain 0	Chain 1
700	1940	8.51	8.53	8.48	8.48	8.44	8.45
900	1960	8.39	8.43	8.35	8.42	8.32	8.39
1100	1980	8.38	8.44	8.32	8.42	8.30	8.37

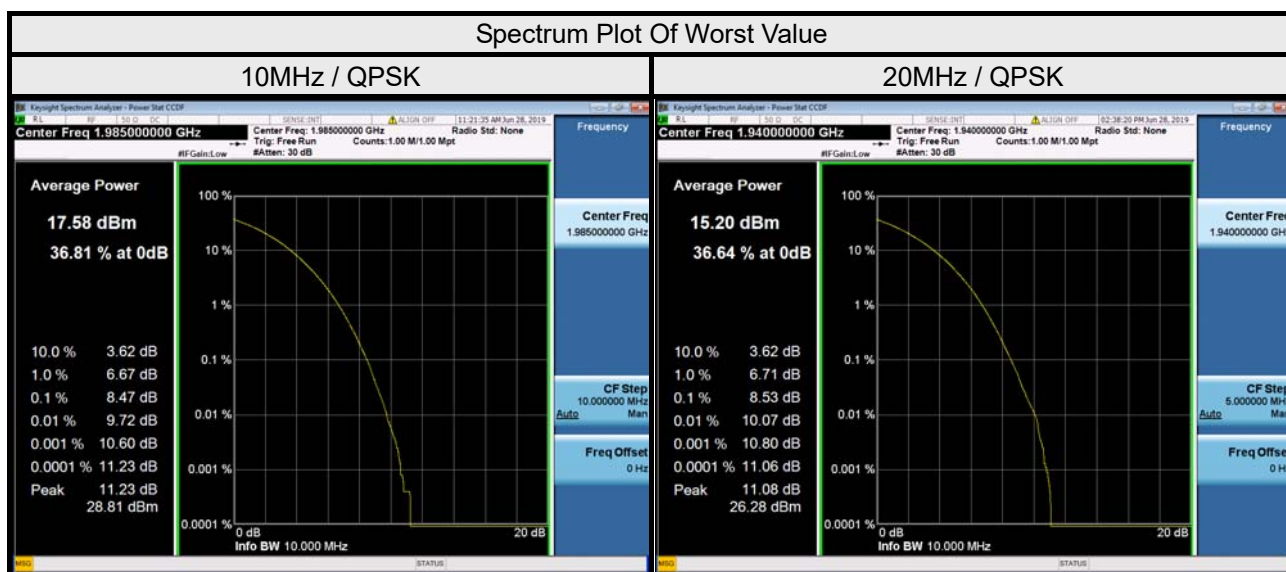

4.7 Conducted Spurious Emissions

4.7.1 Limits of Conducted Spurious Emissions Measurement

The power of any emission outside of the authorized operating frequency ranges must be attenuated below the transmitting power (P) by a factor of at least $43 + 10 \log(P)$ dB. The emission limit equal to -13 dBm.

Note: The results for each of the transmit chains shall be individually compared with the limits after these limits have been reduced by $10 \times \log(N)$ (number of active transmit chains).

4.7.2 Test Setup

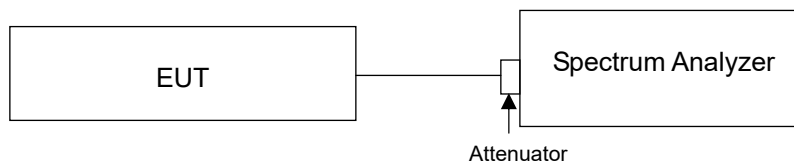

4.7.3 Test Procedure

- a. All measurements were done at low, middle and high operational frequency range.
- b. Measuring frequency range is from 9 kHz to 27GHz. 20dB attenuation pad is connected with spectrum. RBW=1MHz and VBW=3MHz is used for conducted emission measurement.

4.7.4 Test Results

LTE Band 2

Channel Band width: 10MHz

Channel 650

Chain 0

Chain 1

Frequency Range : 9kHz~1GHz

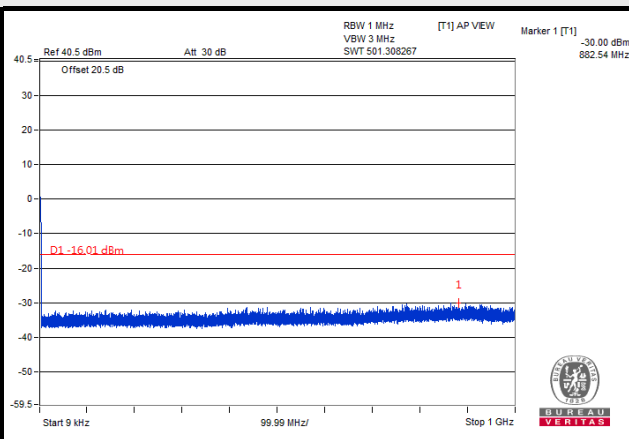
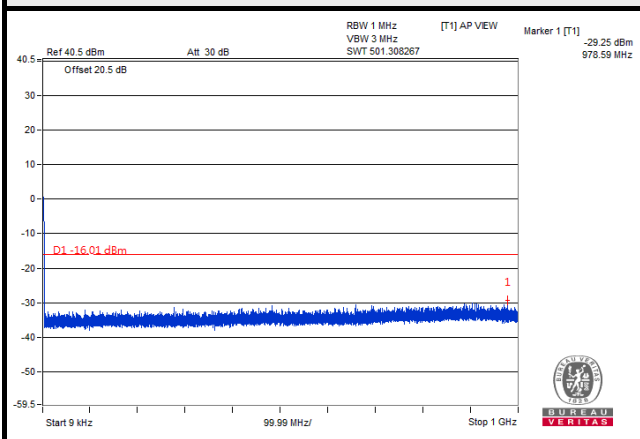

Frequency Range : 1GHz~3GHz

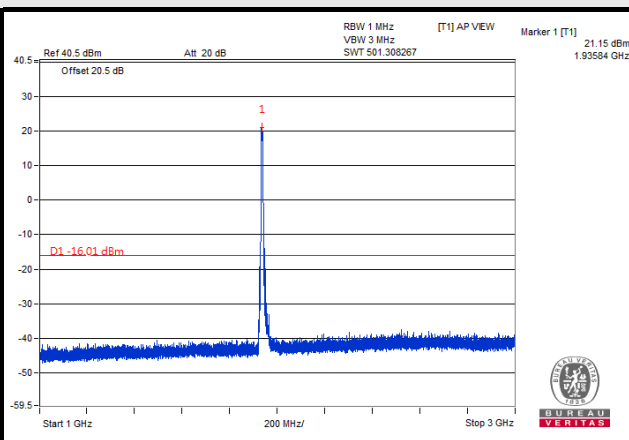
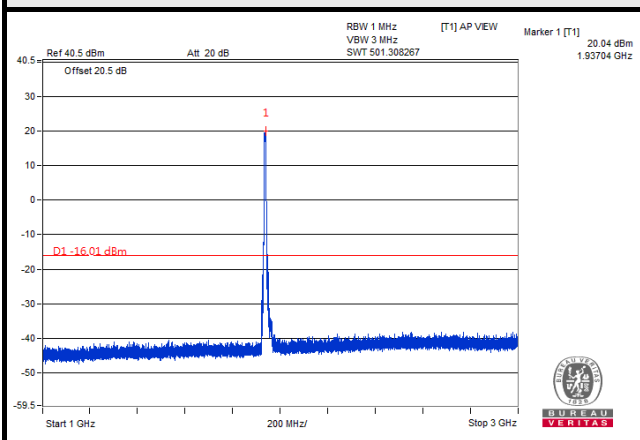

Frequency Range : 3GHz~27GHz

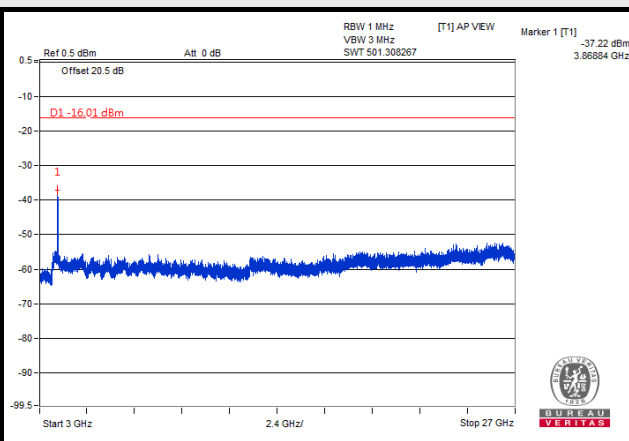
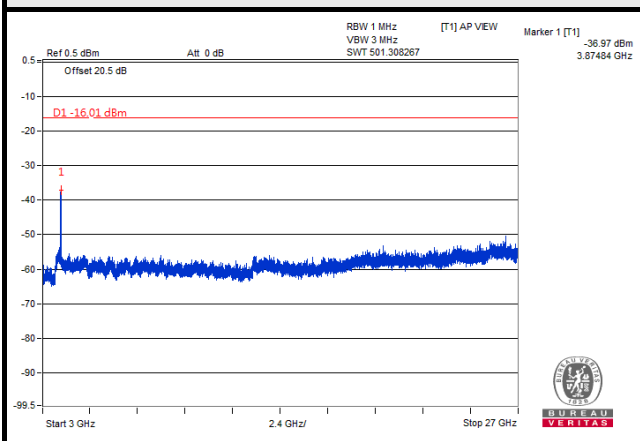

LTE Band 2

Channel Band width: 10MHz

Channel 900

Chain 0

Chain 1

Frequency Range : 9kHz~1GHz

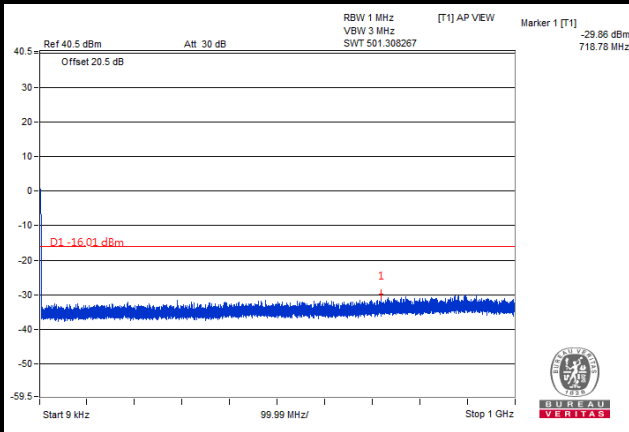
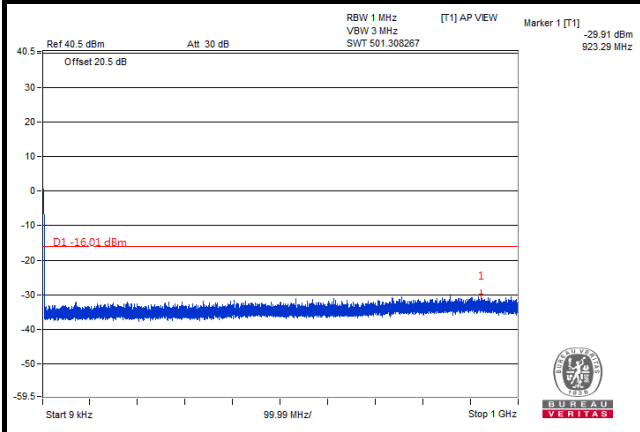

Frequency Range : 1GHz~3GHz

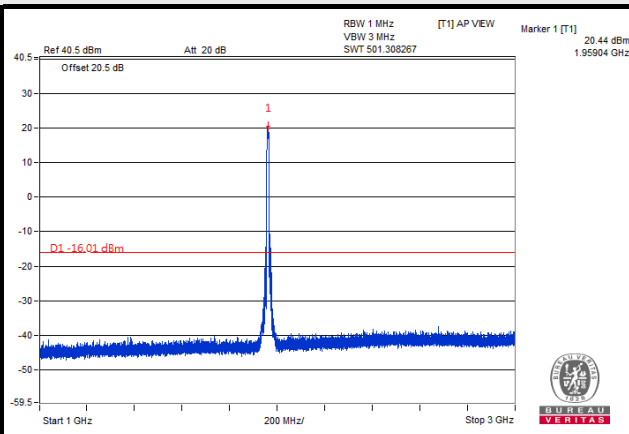
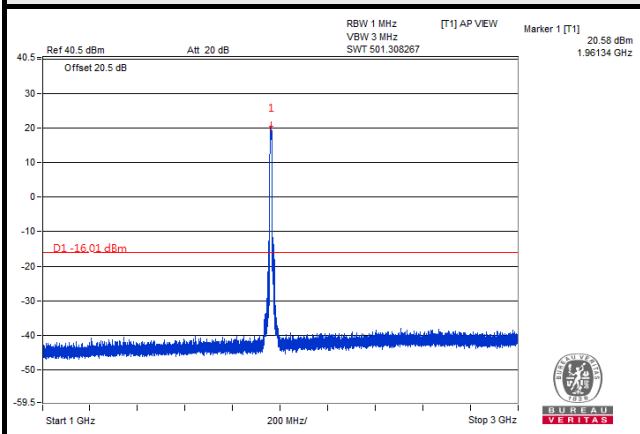

Frequency Range : 3GHz~27GHz

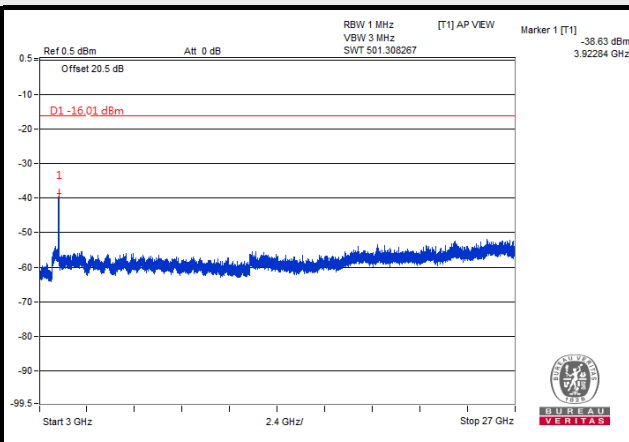
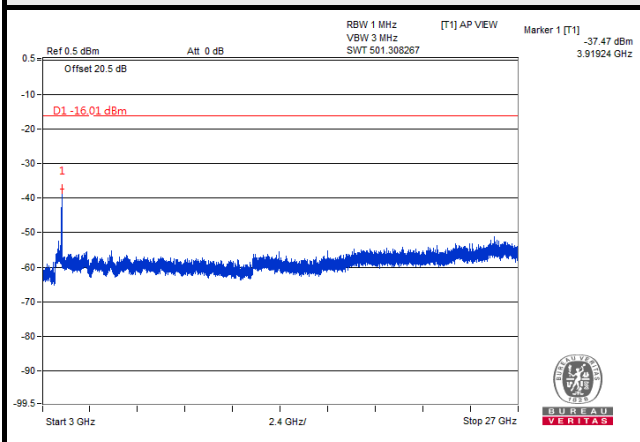

LTE Band 2

Channel Band width: 10MHz

Channel 1150

Chain 0

Chain 1

Frequency Range : 9kHz~1GHz

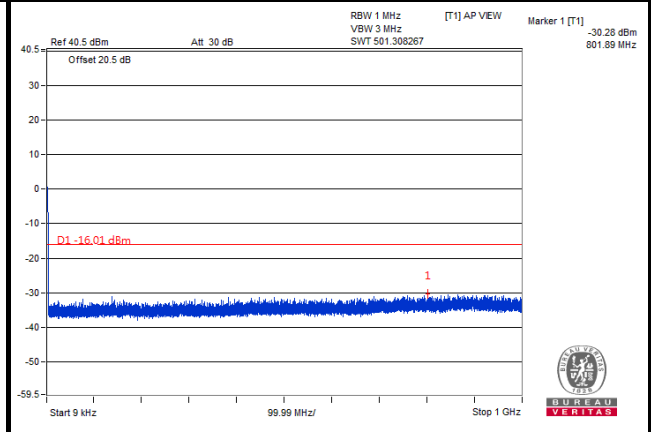
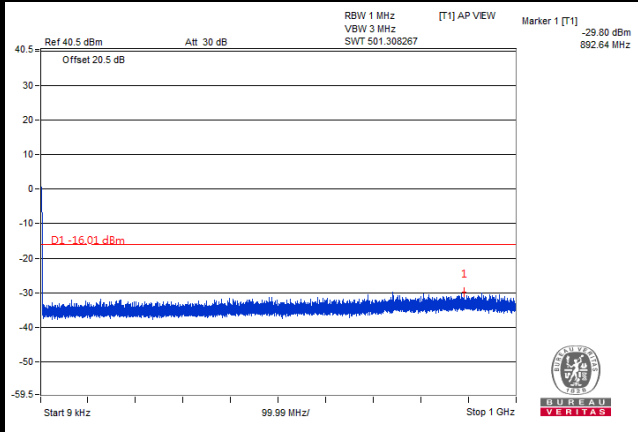

Frequency Range : 1GHz~3GHz

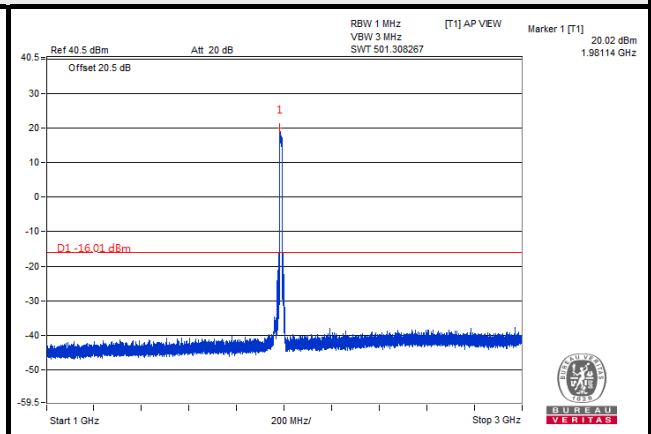
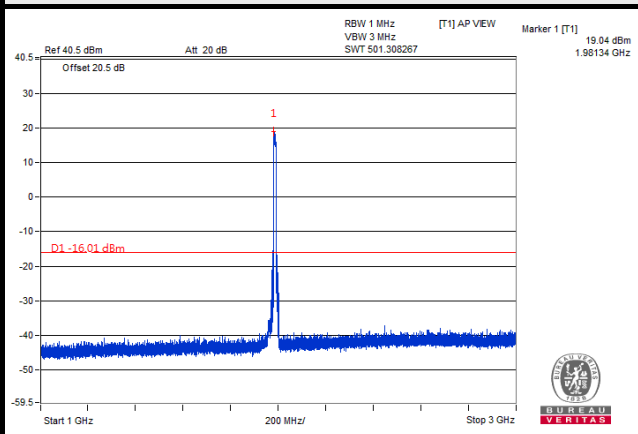

Frequency Range : 3GHz~27GHz

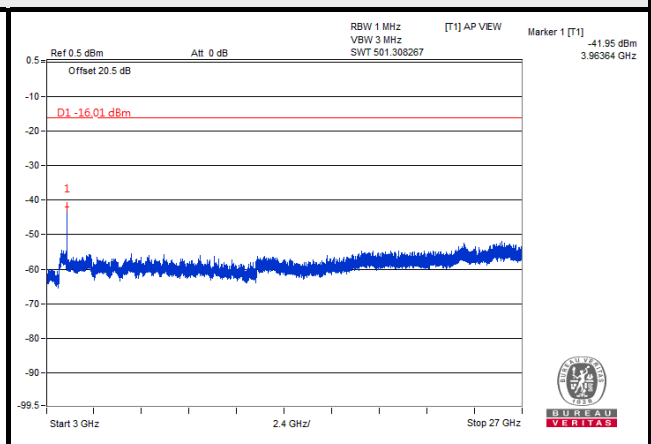
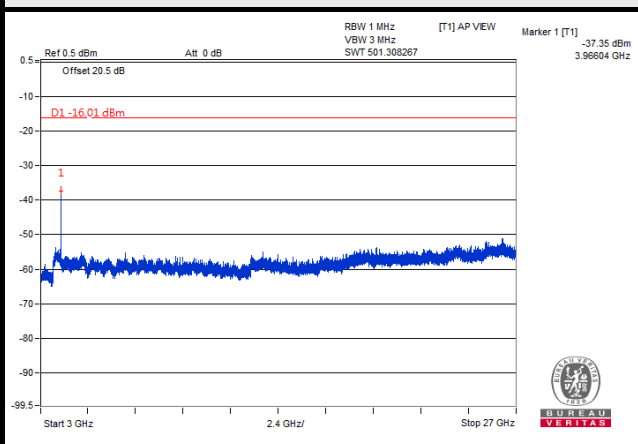

LTE Band 2

Channel Band width: 20MHz

Channel 700

Chain 0

Chain 1

Frequency Range : 9kHz~1GHz

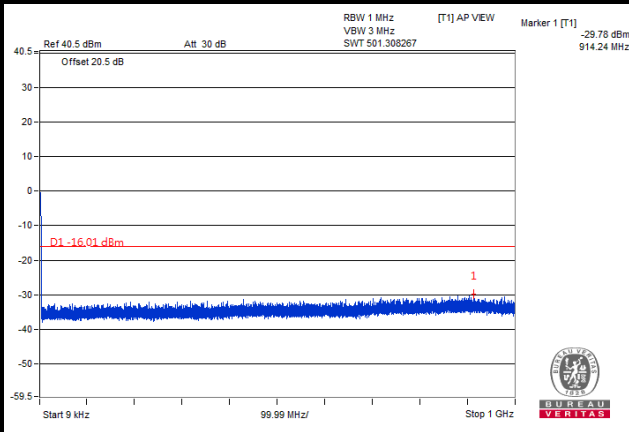
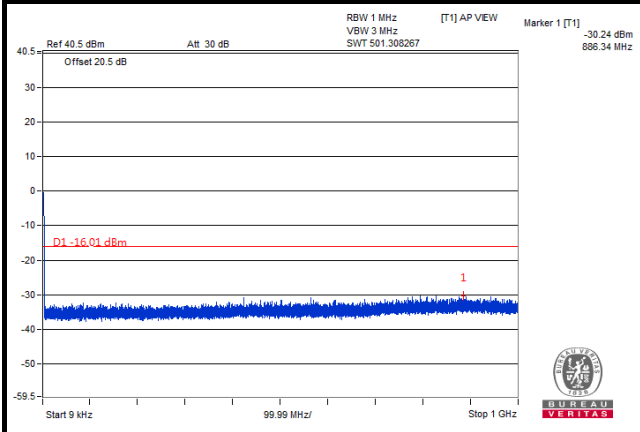

Frequency Range : 1GHz~3GHz

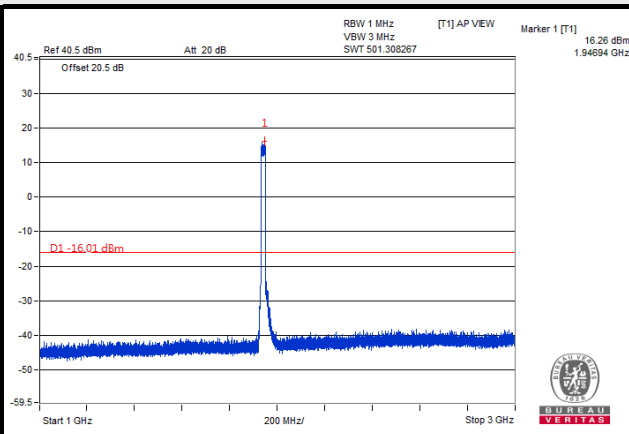
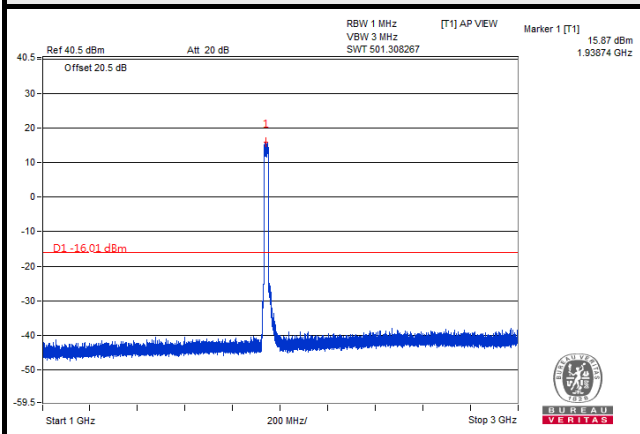

Frequency Range : 3GHz~27GHz

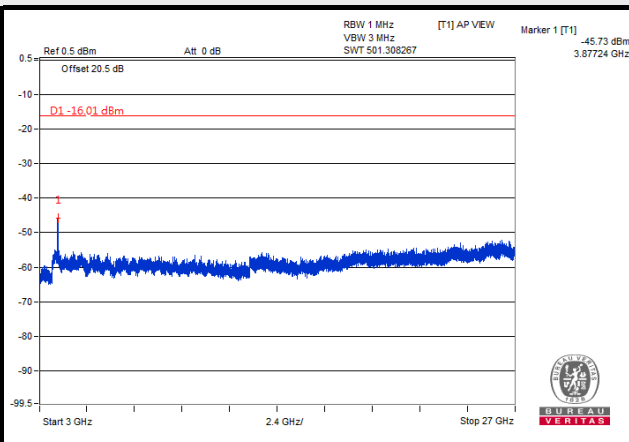
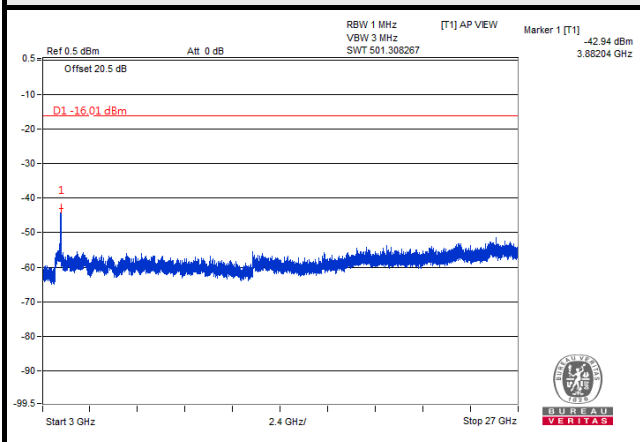

LTE Band 2

Channel Band width: 20MHz

Channel 900

Chain 0

Chain 1

Frequency Range : 9kHz~1GHz

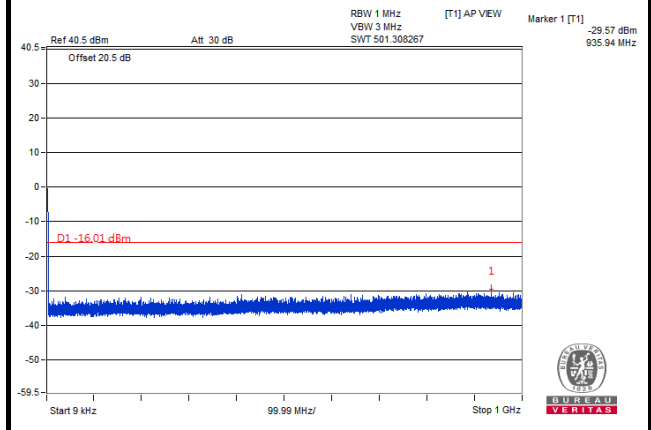
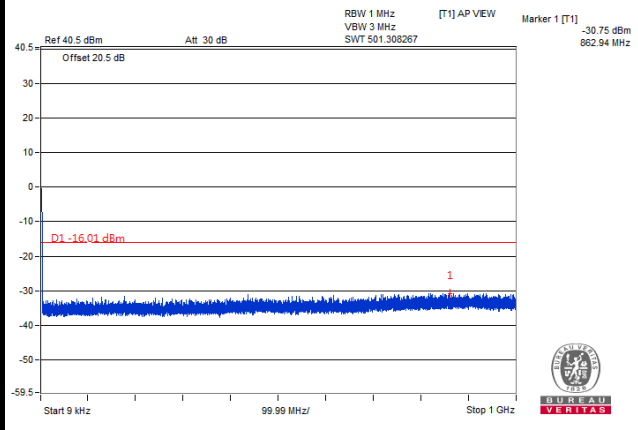

Frequency Range : 1GHz~3GHz

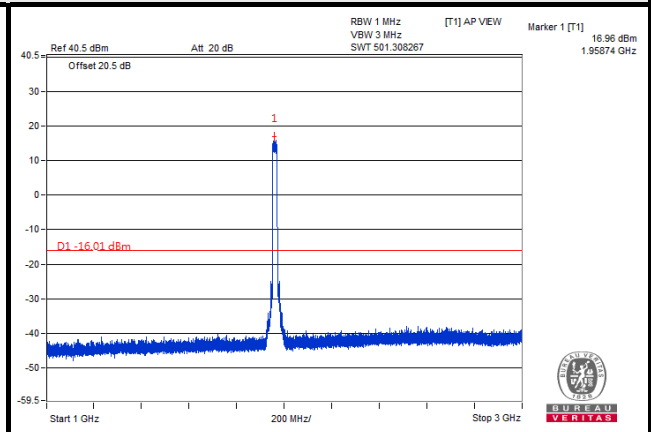
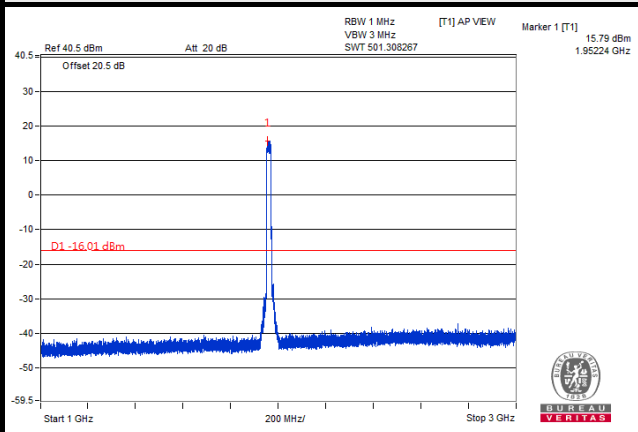

Frequency Range : 3GHz~27GHz

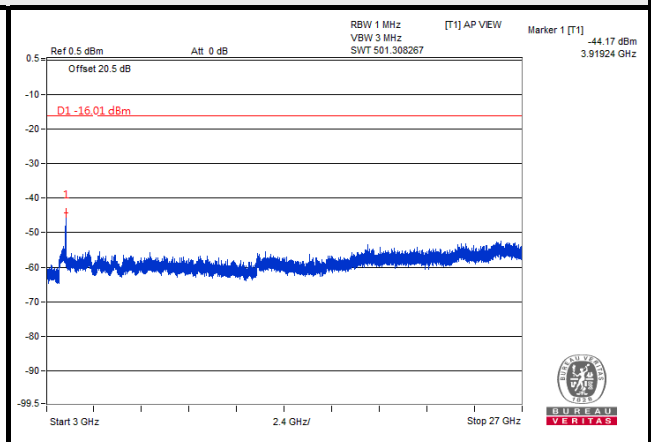
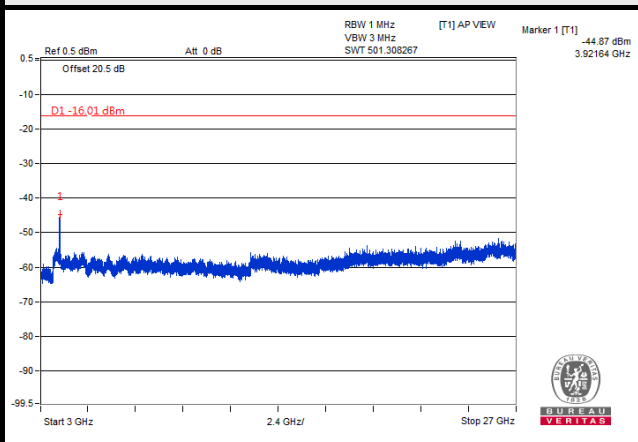

LTE Band 2

Channel Band width: 20MHz

Channel 1100

Chain 0

Chain 1

Frequency Range : 9kHz~1GHz

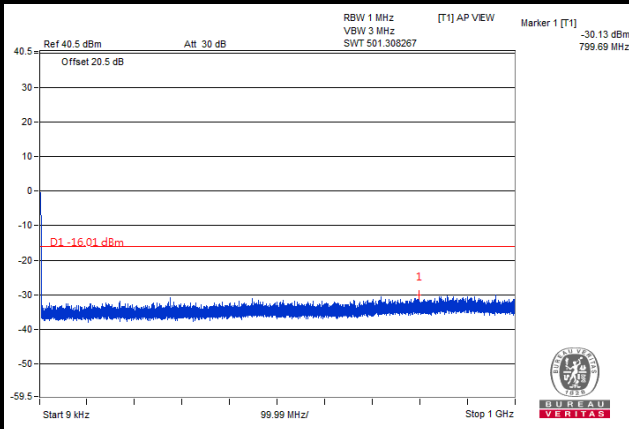
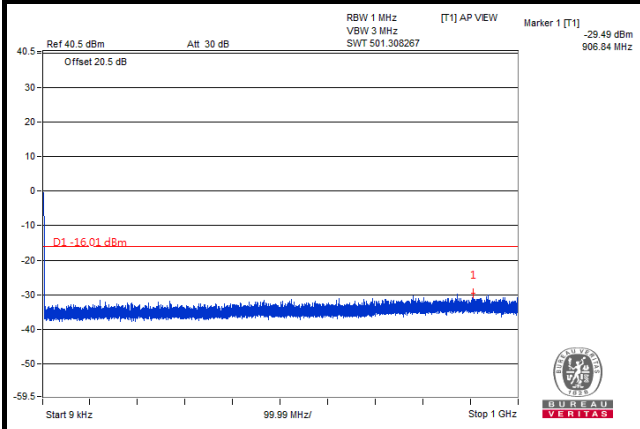

Frequency Range : 1GHz~3GHz

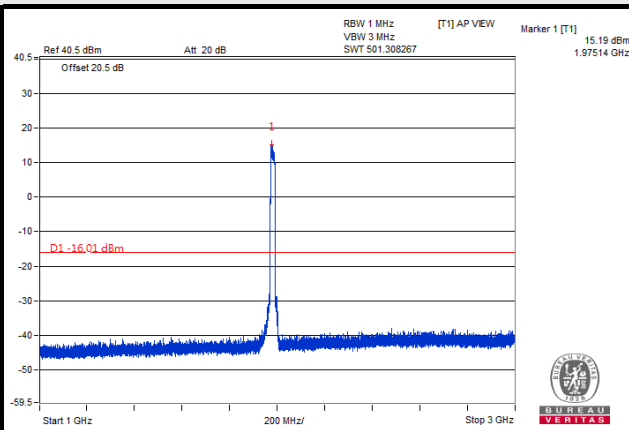
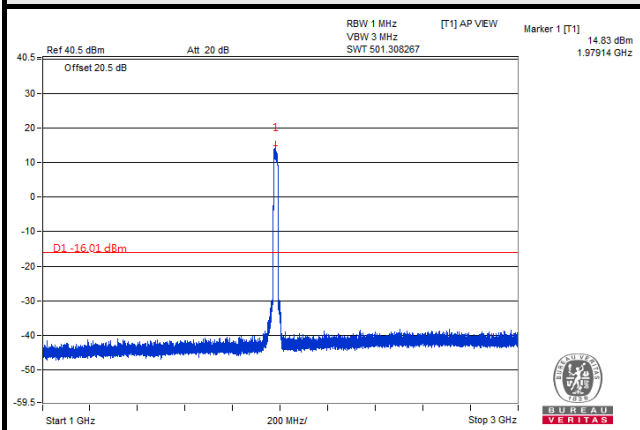

Frequency Range : 3GHz~27GHz

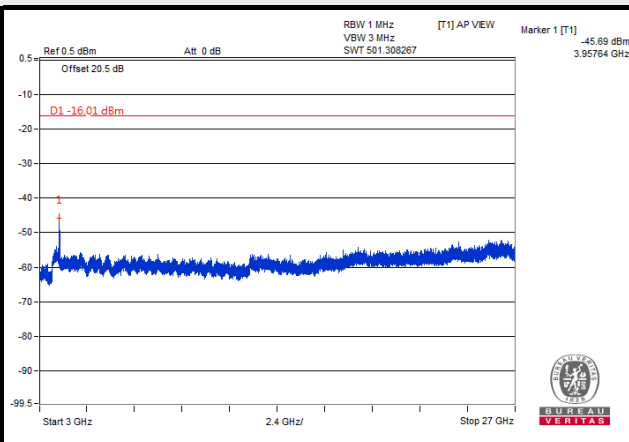
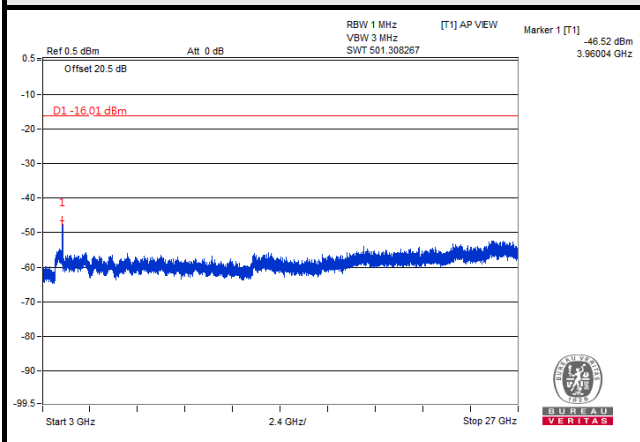

4.8 Radiated Emission Measurement

4.8.1 Limits of Radiated Emission Measurement

The power of any emission outside of the authorized operating frequency ranges must be attenuated below the transmitting power (P) by a factor of at least $43 + 10 \log(P)$ dB. The emission limit equal to -13dBm .

4.8.2 Test Procedure

- a. Substitution method is used for E.I.R.P measurement. In the semi-anechoic chamber, EUT placed on the 0.8m(below or equal 1GHz) and/or 1.5m(above 1GHz) height of Turn Table, rotated the table around 360 degrees to search the maximum radiation power and receiver antenna shall be rotated vertical and horizontal polarization and moved height from 1m to 4m to find the maximum polar radiated power. The "Read Value" is the spectrum reading the maximum power value.
- b. The substitution horn antenna is substituted for EUT at the same position and signals generator export the CW signal to the substitution antenna via a TX cable. Rotated the Turn Table and moved receiving antenna to find the maximum radiation power. Adjust output power level of S.G to get a Value of spectrum reading equal to "Read Value " of step a. Record the power level of S.G
- c. EIRP = Output power level of S.G – TX cable loss + Antenna gain of substitution horn. E.R.P power can be calculated form E.I.R.P power by subtracting the gain of dipole, E.R.P power = E.I.R.P power - 2.15dBi.

Note: The resolution bandwidth and video bandwidth of test receiver/spectrum analyzer is 1MHz/3MHz.

4.8.3 Deviation from Test Standard

No deviation.

4.8.4 Test Setup

For Radiated Emission below or equal 1GHz

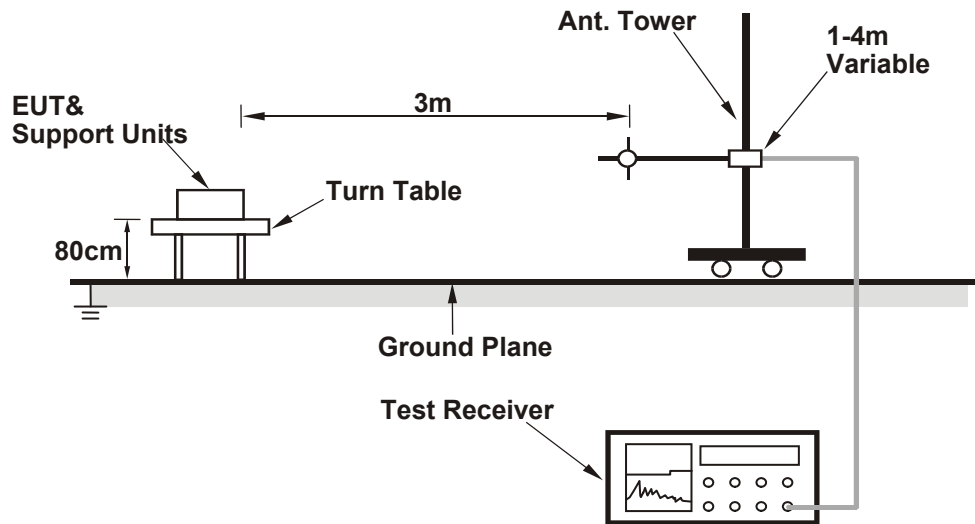

For Radiated Emission above 1GHz

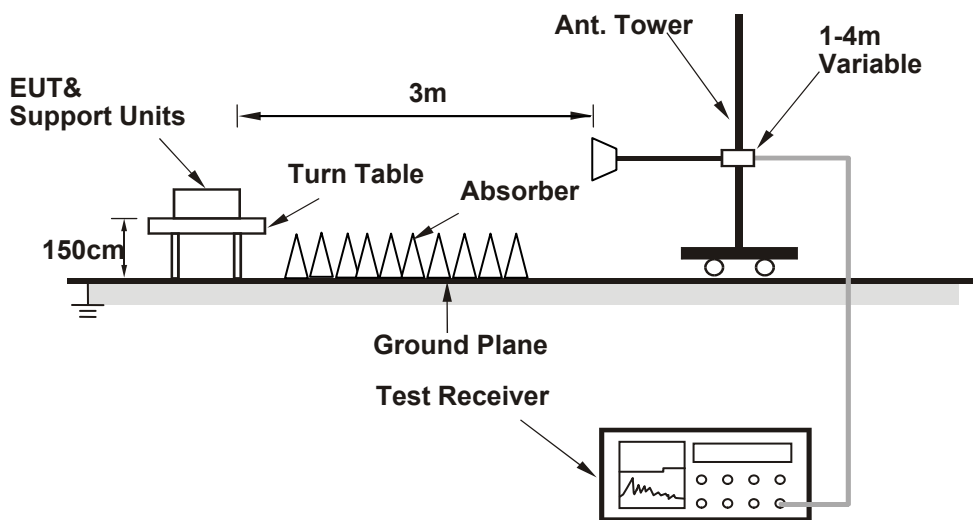

For the actual test configuration, please refer to the attached file (Test Setup Photo).

4.8.5 Test Results

Below 1GHz

LTE Band 2

Channel Bandwidth: 10MHz

MODE	TX Channel 650		Frequency Range	Below 1000 MHz			
ANTENNA POLARITY & TEST DISTANCE: HORIZONTAL AT 3 M							
NO.	FREQ. (MHz)	READING (dBm)	S.G POWER VALUE (dBm)	CORRECTION FACTOR (dB)	EIRP (dBm)	LIMIT (dBm)	MARGIN (dB)
1	116.09	-73.82	-91.45	12.51	-78.94	-13.00	-65.94
2	184.72	-61.23	-82.31	13.24	-69.07	-13.00	-56.07
3	275.05	-67.21	-85.56	15.46	-70.10	-13.00	-57.10
4	325.00	-58.62	-76.38	16.97	-59.41	-13.00	-46.41
5	374.96	-67.58	-85.46	18.25	-67.21	-13.00	-54.21
6	499.96	-71.60	-88.91	21.29	-67.62	-13.00	-54.62
ANTENNA POLARITY & TEST DISTANCE: VERTICAL AT 3 M							
NO.	FREQ. (MHz)	READING (dBm)	S.G POWER VALUE (dBm)	CORRECTION FACTOR (dB)	EIRP (dBm)	LIMIT (dBm)	MARGIN (dB)
1	35.58	-67.17	-84.40	13.20	-71.20	-13.00	-58.20
2	224.97	-57.91	-78.18	12.80	-65.38	-13.00	-52.38
3	325.00	-62.15	-79.05	16.97	-62.08	-13.00	-49.08
4	374.96	-63.64	-81.24	18.25	-62.99	-13.00	-49.99
5	474.99	-72.00	-90.90	20.87	-70.03	-13.00	-57.03
6	624.97	-77.16	-95.29	24.33	-70.96	-13.00	-57.96

NOTE: Power Value(dBm) = S.G Power Value(dBm) + Correction Factor(dB)

Channel Bandwidth: 20MHz

MODE	TX Channel 700		Frequency Range	Below 1000 MHz			
ANTENNA POLARITY & TEST DISTANCE: HORIZONTAL AT 3 M							
NO.	FREQ. (MHz)	READING (dBm)	S.G POWER VALUE (dBm)	CORRECTION FACTOR (dB)	EIRP (dBm)	LIMIT (dBm)	MARGIN (dB)
1	184.96	-60.45	-81.57	13.23	-68.34	-13.00	-55.34
2	224.97	-61.18	-81.82	12.80	-69.02	-13.00	-56.02
3	275.05	-67.40	-85.75	15.46	-70.29	-13.00	-57.29
4	325.00	-58.14	-75.90	16.97	-58.93	-13.00	-45.93
5	374.96	-66.10	-83.98	18.25	-65.73	-13.00	-52.73
6	499.96	-71.73	-89.04	21.29	-67.75	-13.00	-54.75
ANTENNA POLARITY & TEST DISTANCE: VERTICAL AT 3 M							
NO.	FREQ. (MHz)	READING (dBm)	S.G POWER VALUE (dBm)	CORRECTION FACTOR (dB)	EIRP (dBm)	LIMIT (dBm)	MARGIN (dB)
1	35.70	-64.52	-81.63	13.23	-68.40	-13.00	-55.40
2	184.96	-66.22	-87.68	13.23	-74.45	-13.00	-61.45
3	224.97	-58.79	-79.06	12.80	-66.26	-13.00	-53.26
4	275.05	-69.34	-88.39	15.46	-72.93	-13.00	-59.93
5	325.00	-63.01	-79.91	16.97	-62.94	-13.00	-49.94
6	374.96	-65.41	-83.01	18.25	-64.76	-13.00	-51.76

NOTE: Power Value(dBm) = S.G Power Value(dBm) + Correction Factor(dB)

Above 1GHz

LTE Band 2

Channel Bandwidth: 10MHz

MODE		TX Channel 650		Frequency Range		Above 1000MHz	
ANTENNA POLARITY & TEST DISTANCE: HORIZONTAL AT 3 M							
NO.	FREQ. (MHz)	READING (dBm)	S.G POWER VALUE (dBm)	CORRECTION FACTOR (dB)	EIRP (dBm)	LIMIT (dBm)	MARGIN (dB)
1	3869.79	-57.33	-65.09	12.84	-52.25	-13.00	-39.25
ANTENNA POLARITY & TEST DISTANCE: VERTICAL AT 3 M							
NO.	FREQ. (MHz)	READING (dBm)	S.G POWER VALUE (dBm)	CORRECTION FACTOR (dB)	EIRP (dBm)	LIMIT (dBm)	MARGIN (dB)
1	3872.06	-44.55	-52.57	12.85	-39.72	-13.00	-26.72
MODE		TX Channel 900		Frequency Range		Above 1000MHz	
ANTENNA POLARITY & TEST DISTANCE: HORIZONTAL AT 3 M							
NO.	FREQ. (MHz)	READING (dBm)	S.G POWER VALUE (dBm)	CORRECTION FACTOR (dB)	EIRP (dBm)	LIMIT (dBm)	MARGIN (dB)
1	3920.19	-60.24	-68.14	12.95	-55.19	-13.00	-42.19
ANTENNA POLARITY & TEST DISTANCE: VERTICAL AT 3 M							
NO.	FREQ. (MHz)	READING (dBm)	S.G POWER VALUE (dBm)	CORRECTION FACTOR (dB)	EIRP (dBm)	LIMIT (dBm)	MARGIN (dB)
1	3921.46	-49.85	-57.93	12.95	-44.98	-13.00	-31.98
MODE		TX Channel 1150		Frequency Range		Above 1000MHz	
ANTENNA POLARITY & TEST DISTANCE: HORIZONTAL AT 3 M							
NO.	FREQ. (MHz)	READING (dBm)	S.G POWER VALUE (dBm)	CORRECTION FACTOR (dB)	EIRP (dBm)	LIMIT (dBm)	MARGIN (dB)
1	3971.45	-58.78	-66.70	13.06	-53.64	-13.00	-40.64
ANTENNA POLARITY & TEST DISTANCE: VERTICAL AT 3 M							
NO.	FREQ. (MHz)	READING (dBm)	S.G POWER VALUE (dBm)	CORRECTION FACTOR (dB)	EIRP (dBm)	LIMIT (dBm)	MARGIN (dB)
1	3972.65	-49.55	-57.59	13.07	-44.52	-13.00	-31.52

NOTE: Power Value(dBm) = S.G Power Value(dBm) + Correction Factor(dB)

Channel Bandwidth: 20MHz

MODE		TX Channel 700		Frequency Range		Above 1000MHz	
ANTENNA POLARITY & TEST DISTANCE: HORIZONTAL AT 3 M							
NO.	FREQ. (MHz)	READING (dBm)	S.G POWER VALUE (dBm)	CORRECTION FACTOR (dB)	EIRP (dBm)	LIMIT (dBm)	MARGIN (dB)
1	3883.64	-60.53	-68.35	12.87	-55.48	-13.00	-42.48
ANTENNA POLARITY & TEST DISTANCE: VERTICAL AT 3 M							
NO.	FREQ. (MHz)	READING (dBm)	S.G POWER VALUE (dBm)	CORRECTION FACTOR (dB)	EIRP (dBm)	LIMIT (dBm)	MARGIN (dB)
1	3886.39	-51.65	-59.72	12.88	-46.84	-13.00	-33.84
MODE		TX Channel 900		Frequency Range		Above 1000MHz	
ANTENNA POLARITY & TEST DISTANCE: HORIZONTAL AT 3 M							
NO.	FREQ. (MHz)	READING (dBm)	S.G POWER VALUE (dBm)	CORRECTION FACTOR (dB)	EIRP (dBm)	LIMIT (dBm)	MARGIN (dB)
1	3922.46	-60.75	-68.65	12.96	-55.69	-13.00	-42.69
ANTENNA POLARITY & TEST DISTANCE: VERTICAL AT 3 M							
NO.	FREQ. (MHz)	READING (dBm)	S.G POWER VALUE (dBm)	CORRECTION FACTOR (dB)	EIRP (dBm)	LIMIT (dBm)	MARGIN (dB)
1	3918.64	-52.14	-60.23	12.95	-47.28	-13.00	-34.28
MODE		TX Channel 1100		Frequency Range		Above 1000MHz	
ANTENNA POLARITY & TEST DISTANCE: HORIZONTAL AT 3 M							
NO.	FREQ. (MHz)	READING (dBm)	S.G POWER VALUE (dBm)	CORRECTION FACTOR (dB)	EIRP (dBm)	LIMIT (dBm)	MARGIN (dB)
1	3963.38	-58.47	-66.39	13.04	-53.35	-13.00	-40.35
ANTENNA POLARITY & TEST DISTANCE: VERTICAL AT 3 M							
NO.	FREQ. (MHz)	READING (dBm)	S.G POWER VALUE (dBm)	CORRECTION FACTOR (dB)	EIRP (dBm)	LIMIT (dBm)	MARGIN (dB)
1	3964.18	-53.97	-62.00	13.04	-48.96	-13.00	-35.96

NOTE: Power Value(dBm) = S.G Power Value(dBm) + Correction Factor(dB)

5 Pictures of Test Arrangements

Please refer to the attached file (Test Setup Photo).

Appendix – Information of the Testing Laboratories

We, Bureau Veritas Consumer Products Services (H.K.) Ltd., Taoyuan Branch, were founded in 1988 to provide our best service in EMC, Radio, Telecom and Safety consultation. Our laboratories are FCC recognized accredited test firms and accredited according to ISO/IEC 17025.

If you have any comments, please feel free to contact us at the following:

Lin Kou EMC/RF Lab

Tel: 886-2-26052180

Fax: 886-2-26051924

Hsin Chu EMC/RF/Telecom Lab

Tel: 886-3-6668565

Fax: 886-3-6668323

Hwa Ya EMC/RF/Safety Lab

Tel: 886-3-3183232

Fax: 886-3-3270892

Email: service.adt@tw.bureauveritas.com

Web Site: www.bureauveritas-adt.com

The address and road map of all our labs can be found in our web site also.

--- END ---