

MEASUREMENT REPORT

FCC PART 15 Subpart D

FCC ID: P27SKF3R0

Applicant: Sercomm Corporation

Application Type: Certification

Product: Keyfob

Model No.: SKF3R0-29xxxxx (the 1st x should be “blank” or “-”; the rest x could be 0 to 9, A to Z, a to z, “blank” or “-”, for the marketing purpose)

Brand Name: ADT

FCC Classification: Unlicensed PCS portable Tx worn on body (PUT)

FCC Rule Part(s): FCC Part 15, Subpart D

Test Procedure(s): ANSI C63.17-2013

Test Date: April 16 ~ May 06, 2020

Reviewed By: 
(Sunny Sun)

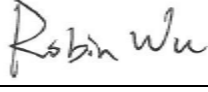
Approved By: 
(Robin Wu)



The test results relate only to the samples tested.

This equipment has been shown to be capable of compliance with the applicable technical standards as indicated in the measurement report and was tested in accordance with the measurement procedures specified in ANSI C63.17. Test results reported herein relate only to the item(s) tested.

The test report shall not be reproduced except in full without the written approval of MRT Technology (Suzhou) Co., Ltd.

Revision History

Report No.	Version	Description	Issue Date	Note
2004RSU031-U1	Rev. 01	Initial Report	05-06-2020	Valid

CONTENTS

Description	Page
General Information	6
1. INTRODUCTION	7
1.1. Scope	7
1.2. MRT Test Location	7
2. PRODUCT INFORMATION	8
2.1. Feature of Equipment under Test	8
2.2. Working Frequencies	8
2.3. Test Software	8
2.4. EMI Suppression Device(s)/Modifications	8
2.5. Labeling Requirements	9
2.6. Automatic Discontinuation of Transmission	9
3. DESCRIPTION of TEST	10
3.1. Evaluation Procedure	10
3.2. AC Line Conducted Emissions	10
4. ANTENNA REQUIREMENTS	11
5. TEST EQUIPMENT CALIBRATION DATE	12
6. MEASUREMENT UNCERTAINTY	14
7. TEST RESULT	15
7.1. Summary	15
7.2. Power Line Conducted Emissions	16
7.2.1. Test Limit	16
7.2.2. Test Setup	16
7.2.3. Test Result	16
7.3. Emission Bandwidth Measurement	17
7.3.1. Test Limit	17
7.3.2. Test Procedure used	17
7.3.3. Test Setup	17
7.3.4. Test Result	18
7.4. Peak Power Output	19
7.4.1. Test Limit	19
7.4.2. Test Procedure Used	19
7.4.3. Test Setup	19
7.4.4. Test Result	20

7.5.	Power Spectral Density	21
7.5.1.	Test Limit	21
7.5.2.	Test Procedure Used	21
7.5.3.	Test Setup	21
7.5.4.	Test Result	22
7.6.	In-Band Unwanted Emissions	23
7.6.1.	Test Limit	23
7.6.2.	Test Procedure Used	23
7.6.3.	Test Setup	23
7.6.4.	Test Result	24
7.7.	Out-of-Band Emissions, Conducted	25
7.7.1.	Test Limit	25
7.7.2.	Test Procedure Used	25
7.7.3.	Test Setup	25
7.7.4.	Test Result	26
7.8.	Carrier Frequency Stability	29
7.8.1.	Test Limit	29
7.8.2.	Test Procedure Used	29
7.8.3.	Test Setup	29
7.8.4.	Test Result	30
7.9.	Specific Requirements for UPCS Device	31
7.9.1.	Monitoring Time Requirements	31
7.9.1.1.	Test Procedure Used	31
7.9.1.2.	Test Setup	31
7.9.1.3.	Test Reslut	31
7.9.2.	Lowest Monitoring Threshold Requirements	32
7.9.2.1.	Test Procedure Used	32
7.9.2.2.	Test Reslut	32
7.9.3.	Acknowledgements and Transmission Duration Requirements.....	33
7.9.3.1.	Test Procedure Used	33
7.9.3.2.	Test Reslut	33
7.9.4.	Least Interfered Channel (LIC) Selection Requirements	34
7.9.4.1.	Test Procedure Used	34
7.9.4.2.	Test Reslut	34
7.9.5.	Random waiting Requirements	35
7.9.5.1.	Test Procedure Used	35
7.9.5.2.	Test Reslut	35
7.9.6.	Monitoring Bandwidth Requirements.....	36
7.9.6.1.	Test Procedure Used	36

7.9.6.2.	Test Reslut	36
7.9.7.	Monitoring Antenna Requirements	37
7.9.7.1.	Test Procedure Used	37
7.9.7.2.	Test Reslut	37
7.9.8.	Monitoring Antenna Requirements	38
7.9.8.1.	Test Procedure Used	38
7.9.8.2.	Test Reslut	38
7.9.9.	Dual Access Criteria Check Requirements	39
7.9.9.1.	Test Procedure Used	39
7.9.9.2.	Test Reslut	39
7.9.10.	Alternative monitoring interval for co-located devices Requirements	40
7.9.10.1.	Test Procedure Used	40
7.9.10.2.	Test Reslut	40
7.9.11.	Frame Repetition Stability and Period and Jitter	41
7.9.11.1.	Test Limit	41
7.9.11.2.	Test Procedure Used	41
7.9.11.3.	Test Setup	41
7.9.11.4.	Test Result	41
8.	CONCLUSION	42
	Appendix A - Test Setup Photograph	43
	Appendix B - EUT Photograph	44

General Information

Applicant:	Sercomm Corporation
Applicant Address:	8F, No. 3-1, YuanQu St., NanKang, Taipei 115, Taiwan, R.O.C.
Manufacturer:	Sercomm Corporation
Manufacturer Address:	8F, No. 3-1, YuanQu St., NanKang, Taipei 115, Taiwan, R.O.C.
Test Site:	MRT Technology (Suzhou) Co., Ltd
Test Site Address:	D8 Building, No.2 Tian'edang Rd., Wuzhong Economic Development Zone, Suzhou, China
Test Device Serial No.:	N/A <input type="checkbox"/> Production <input checked="" type="checkbox"/> Pre-Production <input type="checkbox"/> Engineering

Test Facility / Accreditations

Measurements were performed at MRT Laboratory located in Tian'edang Rd., Suzhou, China.

- MRT facility is a FCC accredited (MRT Designation No. CN1166) test facility with the site description report on file and has met all the requirements specified in ANSI C63.4-2014.
- MRT facility is an IC registered (MRT Reg. No. 11384A-1) test laboratory with the site description on file at Industry Canada.
- MRT facility is a VCCI registered (R-20025, G-20034, C-20020, T-20020) test laboratory with the site description on file at VCCI Council.
- MRT Lab is accredited to ISO 17025 by the American Association for Laboratory Accreditation (A2LA) under the American Association for Laboratory Accreditation Program (A2LA Cert. No. 3628.01) in EMC, Telecommunications, Radio and SAR testing.



1. INTRODUCTION

1.1. Scope

Measurement and determination of electromagnetic emissions (EMC) of radio frequency devices including intentional and/or unintentional radiators for compliance with the technical rules and regulations of the Federal Communications Commission and the Innovation, Science and Economic Development Canada.

1.2. MRT Test Location

The map below shows the location of the MRT LABORATORY, its proximity to the Taihu Lake. These measurement tests were conducted at the MRT Technology (Suzhou) Co., Ltd. Facility located at D8 Building, No.2 Tian'edang Rd., Wuzhong Economic Development Zone, Suzhou, China. The measurement facility compliant with the test site requirements specified in ANSI C63.4-2014.



2. PRODUCT INFORMATION

2.1. Feature of Equipment under Test

Product Name:	Keyfob
Model No.:	SKF3R0-29xxxxx (the 1st x should be "blank" or "-"; the rest x could be 0 to 9, A to Z, a to z, "blank" or "-", for the marketing purpose)
Brand Name:	ADT
DECT Function:	
Frequency Range:	1921.536 ~ 1928.448MHz
Number of Channels:	5
Maximum Output Power:	9.59dBm
Type of Modulation:	Digital (Gaussian Frequency Shift Keying)
Antenna Gain:	0.63dBi
Antenna Type:	PIFA Antenna

Note: This product has two appearance color, differences do not affect test results.

2.2. Working Frequencies

UPCS CHANNEL	FREQUENCY (MHz)
Upper Band Edge	1930.000
0 (Highest)	1928.448
1	1926.720
2	1924.992
3	1923.264
4 (Lowest)	1921.536
Lowest Band Edge	1920.000

Requirement: FCC 15.303

Within 1920 - 1930 MHz band for isochronous devices

2.3. Test Software

The test software is "RTX2012".

2.4. EMI Suppression Device(s)/Modifications

No EMI suppression device(s) were added and/or no modifications were made during testing.

2.5. Labeling Requirements

Per 2.1074 & 15.19; Docket 95-19

The label shall be permanently affixed at a conspicuous location on the device; instruction manual or pamphlet supplied to the user and be readily visible to the purchaser at the time of purchase. However, when the device is so small wherein placement of the label with specified statement is not practical, only the FCC ID must be displayed on the device per Section 15.19(a)(5). Please see attachment for FCC ID label and label location.

2.6. Automatic Discontinuation of Transmission

Does the EUT transmit Control and Signaling Information?	<input checked="" type="checkbox"/> Yes	<input type="checkbox"/> No
Type of EUT:	<input type="checkbox"/> Initiating Device	<input checked="" type="checkbox"/> Responding Device

The following tests simulate the reaction of the EUT in case of either absence of information to transmit or operational failure after a connection with the companion device is established.

Number	Test	EUT Reaction	Verdict
1	Power removed from EUT	A	Pass
2	Switch Off EUT	N/A	Pass
3	Hook-On by EUT	N/A	Pass
4	Power Removed from Companion Device	B	Pass
5	Switch Off Companion Device	B	Pass
6	Hook-On by Companion Device	B	Pass

A - Connection breakdown, Cease of all transmissions

B - Connection breakdown, EUT transmits control and signaling information

C - Connection breakdown, Companion Device transmits control and signaling information

N/A - Not Applicable (EUT does not have On/Off switch and cannot perform Hook-On)

Requirements, FCC 15.319(f)

The device shall automatically discontinue transmission in case of either absence of information to transmit or operational failure. These provisions are not intended to preclude transmission of control and signaling information or use of repetitive codes used by certain digital technologies to complete frame or burst intervals.

3. DESCRIPTION of TEST

3.1. Evaluation Procedure

All measurements are traceable to national standards.

The tests were conducted on a sample of the equipment for the purpose of demonstrating compliance with FCC CFR47 Part 15D for Isochronous UPCS Devices.

All tests were conducted in accordance with ANSI C63.4-2014 and ANSI C63.17-2013.

3.2. AC Line Conducted Emissions

The line-conducted facility is located inside an 8'x4'x4' shielded enclosure. A 1m x 2m wooden table 80cm high is placed 40cm away from the vertical wall and 80cm away from the sidewall of the shielded room. Two 10kHz-30MHz, 50Ω/50uH Line-Impedance Stabilization Networks (LISNs) are bonded to the shielded room floor. Power to the LISNs is filtered by external high-current high-insertion loss power line filters. These filters attenuate ambient signal noise from entering the measurement lines. These filters are also bonded to the shielded enclosure.

The EUT is powered from one LISN and the support equipment is powered from the second LISN. All interconnecting cables more than 1 meter were shortened to a 1 meter length by non-inductive bundling (serpentine fashion) and draped over the back edge of the test table. All cables were at least 40cm above the horizontal reference ground-plane. Power cables for support equipment were routed down to the second LISN while ensuring that that cables were not draped over the second LISN.

Sufficient time for the EUT, support equipment, and test equipment was allowed in order for them to warm up to their normal operating condition. The RF output of the LISN was connected to the receiver and exploratory measurements were made to determine the frequencies producing the maximum emission from the EUT. The receiver was scanned from 150kHz to 30MHz. The detector function was set to peak mode for exploratory measurements while the bandwidth of the analyzer was set to 9kHz. The EUT, support equipment, and interconnecting cables were arranged and manipulated to maximize each emission. Each emission was also maximized by varying: power lines, the mode of operation or data exchange speed, or support equipment whichever determined the worst-case emission. Once the worst case emissions have been identified, the one EUT cable configuration/arrangement and mode of operation that produced these emissions are used for final measurements on the same test site. The analyzer is set to CISPR quasi-peak and average detectors with a 9kHz resolution bandwidth for final measurements.

An extension cord was used to connect to a single LISN which powered by EUT. The extension cord was calibrated with LISN, the impedance and insertion loss are compliance with the requirements as stated in ANSI C63.17-2013.

4. ANTENNA REQUIREMENTS

Excerpt from §15.203 of the FCC Rules/Regulations:

“An intentional radiator antenna shall be designed to ensure that no antenna other than that furnished by the responsible party can be used with the device. The use of a permanently attached antenna or of an antenna that uses a unique coupling to the intentional radiator shall be considered sufficient to comply with the provisions of this section.”

- The antenna of the unit is **permanently attached**.
- There are no provisions for connection to an external antenna.

Conclusion:

The unit complies with the requirement of §15.203.

5. TEST EQUIPMENT CALIBRATION DATE

Conducted Emissions - SR2

Instrument	Manufacturer	Type No.	Asset No.	Cali. Interval	Cali. Due Date
EMI Test Receiver	R&S	ESR7	MRTSUE06001	1 year	2020/08/01
Two-Line V-Network	R&S	ENV 216	MRTSUE06002	1 year	2020/06/13
Two-Line V-Network	R&S	ENV 216	MRTSUE06003	1 year	2020/06/13
Temperature/Humidity Meter	testo	608-H1	MRTSUE06404	1 year	2020/08/08
Shielding Anechoic Chamber	Mikebang	Chamber-SR2	MRTSUE06214	N/A	N/A

Conducted Test Equipment - TR3

Instrument	Manufacturer	Type No.	Asset No.	Cali. Interval	Cali. Due Date
EXA Signal Analyzer	Agilent	N9030B	MRTSUE06106	1 year	2020/09/03
EXA Signal Analyzer	Keysight	N9010B	MRTSUE06452	1 year	2020/07/11
Power Meter	Agilent	U2021XA	MRTSUE06030	1 year	2020/11/18
USB wideband power sensor	Keysight	U2021XA	MRTSUE06446	1 year	2020/06/30
USB wideband power sensor	Keysight	U2021XA	MRTSUE06447	1 year	2020/06/30
Audio Analyzer	Agilent	U8903B	MRTSUE06143	1 year	2020/06/13
Modulation Analyzer	HP	8901A	MRTSUE06098	1 year	2020/10/10
Wideband Radio Communication Tester	R&S	CMW 500	MRTSUE06243	1 year	2020/11/07
DC Power Supply	GWINSTEK	DPS-3303C	MRTSUE06064	N/A	N/A
Temperature & Humidity Chamber	BAOYT	BYH-150CL	MRTSUE06051	1 year	2020/11/07
Thermohygrometer	testo	608-H1	MRTSUE06401	1 year	2020/08/08

Radiated Spurious Emission - AC1

Instrument	Manufacturer	Type No.	Asset No.	Cali. Interval	Cali. Due Date
EMI Test Receiver	R&S	ESR7	MRTSUE06001	1 year	2020/08/01
PXA Signal Analyzer	Keysight	N9030B	MRTSUE06395	1 year	2020/09/03
Loop Antenna	Schwarzbeck	FMZB 1519	MRTSUE06025	1 year	2020/11/13
Bilog Period Antenna	Schwarzbeck	VULB 9168	MRTSUE06172	1 year	2021/03/31
Horn Antenna	Schwarzbeck	BBHA9120D	MRTSUE06023	1 year	2020/10/13
Broad Band Horn Antenna	Schwarzbeck	BBHA 9170	MRTSUE06024	1 year	2020/12/17
Microwave System Amplifier	Agilent	83017A	MRTSUE06076	1 year	2020/11/15
Preamplifier	Schwarzbeck	BBV 9721	MRTSUE06121	1 year	2020/06/11
Thermohygrometer	Testo	608-H1	MRTSUE06403	1 year	2020/08/08
Anechoic Chamber	TDK	Chamber-AC1	MRTSUE06212	1 year	2020/04/30

Radiated Spurious Emission - AC2

Instrument	Manufacturer	Type No.	Asset No.	Cali. Interval	Cali. Due Date
Spectrum Analyzer	Keysight	N9038A	MRTSUE06125	1 year	2020/08/01
Loop Antenna	Schwarzbeck	FMZB 1519	MRTSUE06025	1 year	2020/11/13
Bilog Period Antenna	Schwarzbeck	VULB 9162	MRTSUE06022	1 year	2020/10/13
Horn Antenna	Schwarzbeck	BBHA9120D	MRTSUE06171	1 year	2020/10/27
Broad Band Horn Antenna	Schwarzbeck	BBHA 9170	MRTSUE06024	1 year	2020/12/17
Broadband Coaxial Preamplifier	Schwarzbeck	BBV 9718	MRTSUE06176	1 year	2020/11/15
Preamplifier	Schwarzbeck	BBV 9721	MRTSUE06121	1 year	2020/06/11
Temperature/Humidity Meter	Minggao	ETH529	MRTSUE06170	1 year	2020/12/13
Anechoic Chamber	RIKEN	Chamber-AC2	MRTSUE06213	1 year	2020/04/30

Software	Version	Function
V3	V8.3.5	EMI Test Software

6. MEASUREMENT UNCERTAINTY

Where relevant, the following test uncertainty levels have been estimated for tests performed on the EUT as specified in CISPR 16-4-2. This uncertainty represents an expanded uncertainty expressed at approximately the 95% confidence level using a coverage factor of $k = 2$.

AC Conducted Emission Measurement - SR2
Measuring Uncertainty for a Level of Confidence of 95% ($U=2Uc(y)$): 150kHz~30MHz: 3.46dB
Radiated Emission Measurement - AC1
The maximum measurement uncertainty is evaluated as: Horizontal: 30MHz~300MHz: 4.07dB 300MHz~1GHz: 3.63dB 1GHz~18GHz: 4.16dB Vertical: 30MHz~300MHz: 4.18dB 300MHz~1GHz: 3.60dB 1GHz~18GHz: 4.76dB
Radiated Emission Measurement - AC2
The maximum measurement uncertainty is evaluated as: Horizontal: 30MHz~300MHz: 3.75dB 300MHz~1GHz: 3.53dB 1GHz~18GHz: 4.28dB Vertical: 30MHz~300MHz: 3.86dB 300MHz~1GHz: 3.53dB 1GHz~18GHz: 4.33dB

7. TEST RESULT

7.1. Summary

Test Item	FCC CFR 47 Paragraph	Verdict
Power Line Conducted Emission	15.207(a)	Note
Digital Modulation Techniques	15.319(b)	Complies
Labeling requirements	15.19(a)(3)	Complies
Antenna Requirement	15.317, 15.203	Complies
Channel Frequencies	15.303	Complies
Automatic discontinuation of transmission	15.319(f)	Complies
Emission Bandwidth	15.323(a)	Complies
In-band emissions	15.323(d)	Complies
Out-of-band emissions	15.323(d)	Complies
Peak Transmit Power and Antenna Gain	15.319(c)(e)	Complies
Power Spectral Density	15.319(d)	Complies
Carrier frequency stability	15.323(f)	Complies
Spurious Emissions (Radiated)	15.319(g)	Complies
Specific Requirements for UPCS	15.323(c)(e)	Complies
Note: The EUT is powered by battery, so this test item is not applicable.		

7.2. Power Line Conducted Emissions

7.2.1. Test Limit

FCC Part 15.207 Limits		
Frequency (MHz)	QP (dB μ V)	AV (dB μ V)
0.15 - 0.50	66 - 56	56 - 46
0.50 - 5.0	56	46
5.0 - 30	60	50

Note 1: The lower limit shall apply at the transition frequencies.

Note 2: The limit decreases linearly with the logarithm of the frequency in the range 0.15MHz to 0.5MHz.

7.2.2. Test Setup

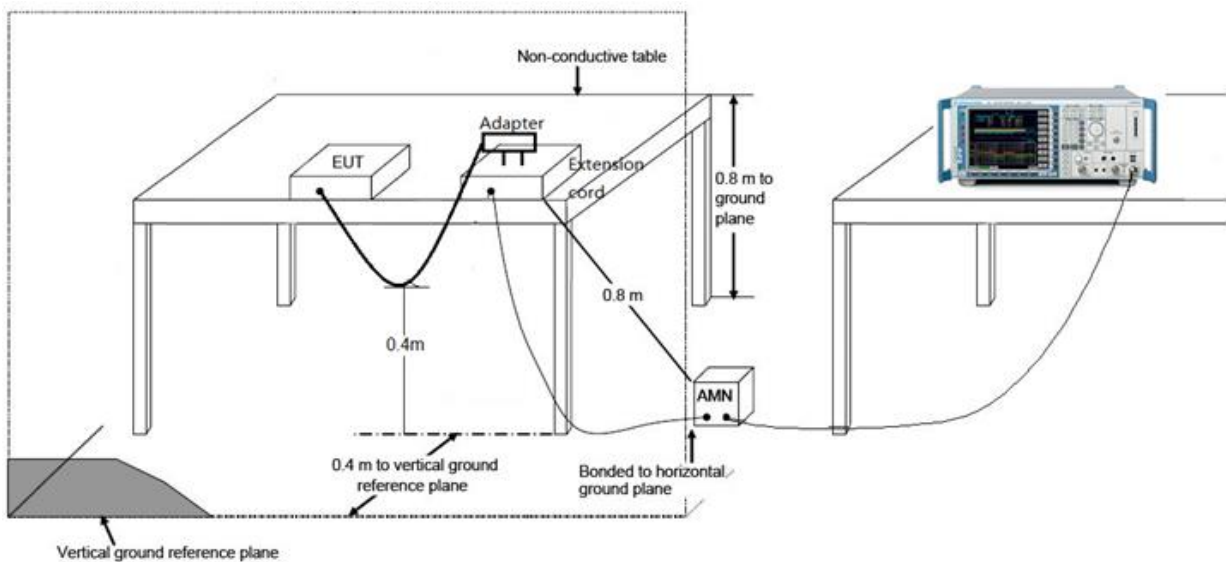

7.2.3. Test Result

The EUT is powered by battery, so this test item is not applicable.

7.3. Emission Bandwidth Measurement

7.3.1. Test Limit

The 26 dB Bandwidth B shall be larger than 50 kHz and less than 2.5MHz.

No requirement for 6 dB and 12 dB Bandwidth. These values are only used for testing Monitoring Bandwidth if the Simple Compliance test fails (ANSI C63.17, clause 7.4).

7.3.2. Test Procedure used

ANSI C63.17, Clause 6.1.3

7.3.3. Test Setup

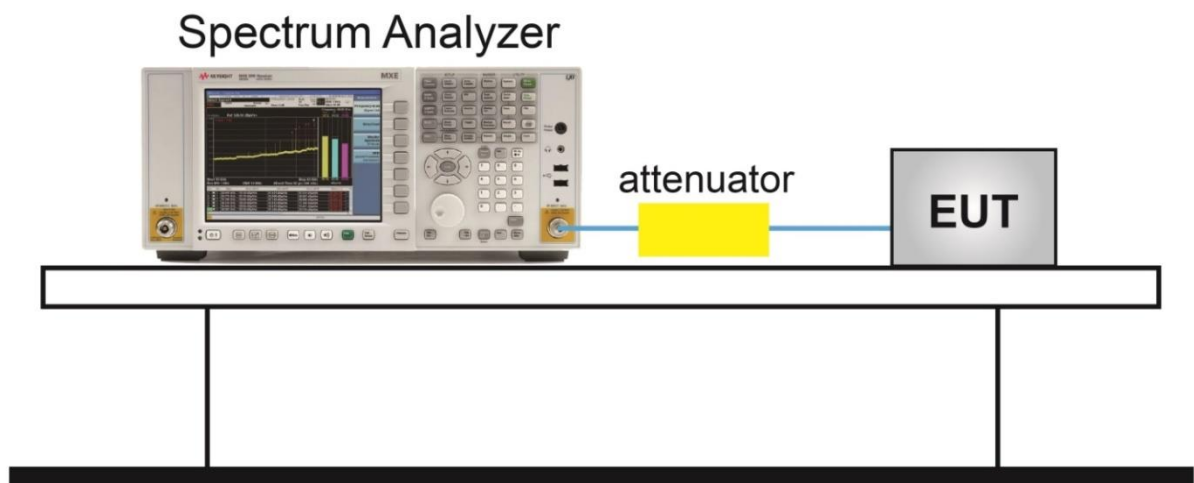

7.3.4. Test Result

Product	Keyfob	Temperature	25.0°C
Test Engineer	Dandy Li	Relative Humidity	64.0%
Test Site	TR3	Test Date	2020/04/20

Channel No.	Frequency (MHz)	Emission Bandwidth (MHz)	Result
26dB Bandwidth			
4	1921.536	1.46	Pass
2	1924.992	1.47	Pass
0	1928.448	1.46	Pass
99% Bandwidth			
4	1921.536	1.25	Pass
2	1924.992	1.26	Pass
0	1928.448	1.25	Pass

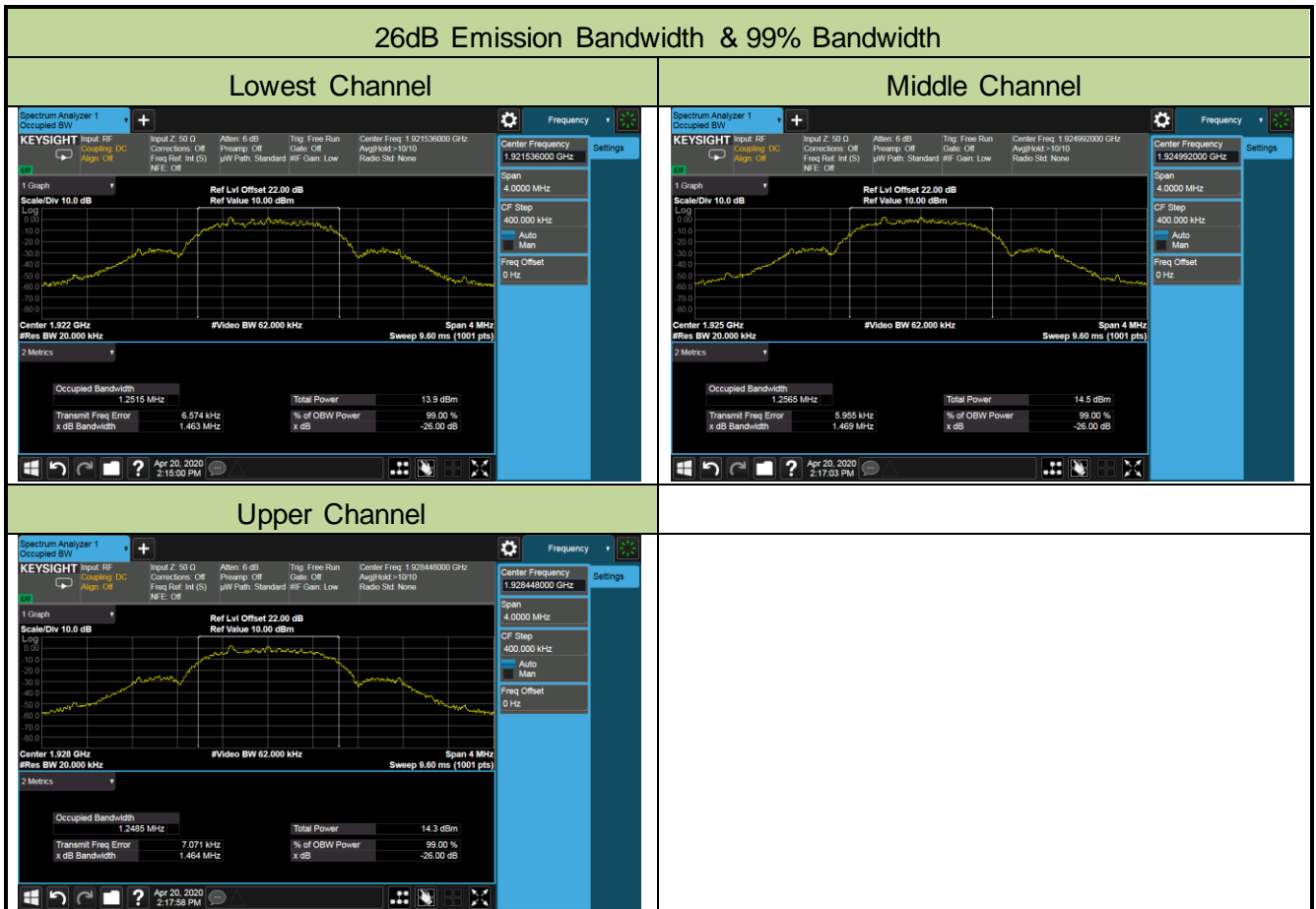

7.4. Peak Power Output

7.4.1. Test Limit

Peak transmit power shall not exceed 100 microwatts multiplied by the square root of the emission bandwidth in Hertz.

The peak transmit power shall be reduced by the amount in decibels that the maximum directional gain of the antenna exceeds 3dBi.

7.4.2. Test Procedure Used

ANSI C63.17, Clause 6.1.2

7.4.3. Test Setup

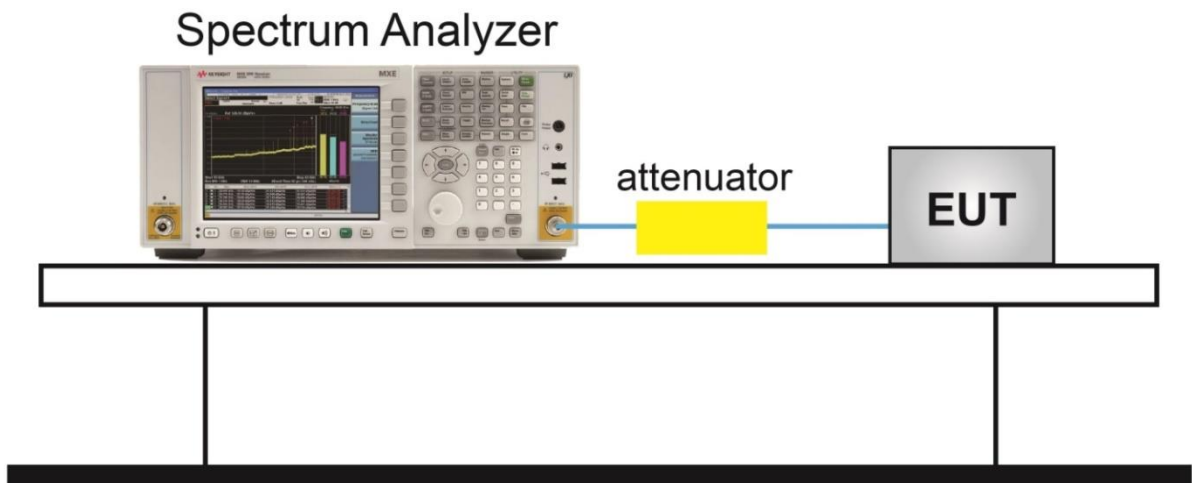

7.4.4. Test Result

Product	Keyfob	Temperature	25.0°C
Test Engineer	Dandy Li	Relative Humidity	64.0%
Test Site	TR3	Test Date	2020/04/20

Channel No.	Frequency (MHz)	Conducted Output Power (dBm)	Maximum Antenna Gain (dBi)	EIPR (dBm)	Limit (dBm)
4	1921.536	9.55	0.63	10.18	≤ 20.84
2	1924.992	9.58	0.63	10.21	≤ 20.84
0	1928.448	9.59	0.63	10.22	≤ 20.84

Note: The min EBW = 1470000Hz

Peak Transmit Power Limit = $10 \cdot \log(100\mu\text{W} \times (\text{EBW})^{1/2} \div 1000) = 20.84\text{dBm}$

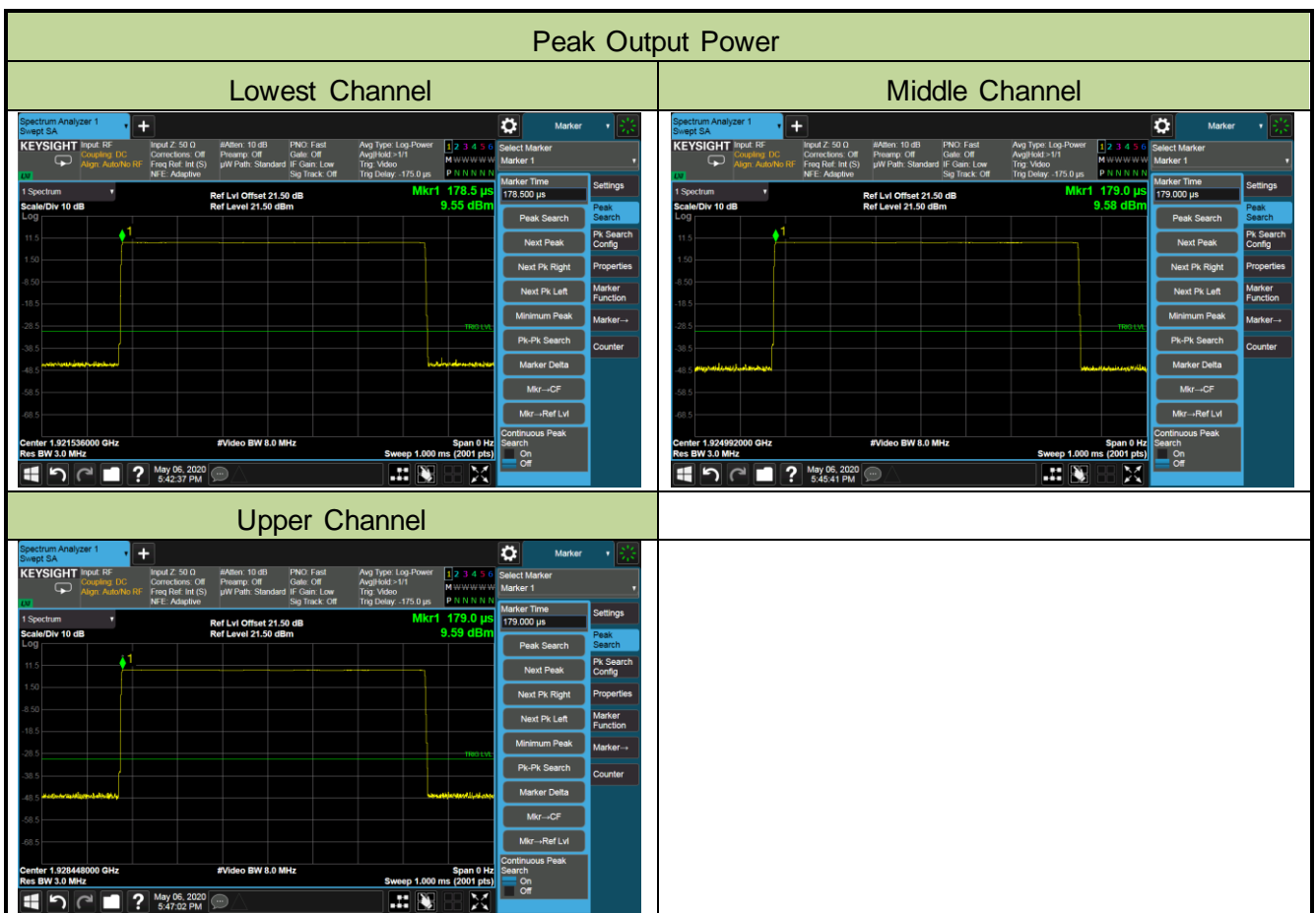

7.5. Power Spectral Density

7.5.1. Test Limit

Power spectral density shall not exceed 3 milliwatts in any 3 kHz bandwidth as measured with a spectrum analyzer having a resolution bandwidth of 3 kHz.

7.5.2. Test Procedure Used

ANSI C63.17, Clause 6.1.5

7.5.3. Test Setup

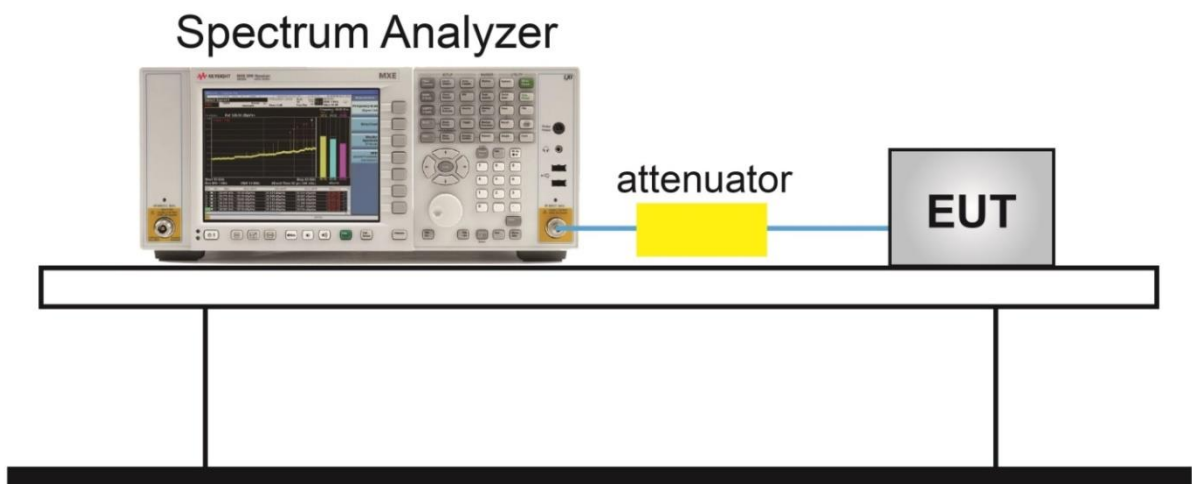

7.5.4. Test Result

Product	Keyfob	Temperature	25.0°C
Test Engineer	Dandy Li	Relative Humidity	64.0%
Test Site	TR3	Test Date	2020/04/20

Channel No.	Frequency (MHz)	Measured PSD (dBm / 3kHz)	Limit (mW / 3kHz)	Result
4	1921.536	-12.77	≤ 3.00	Pass
2	1924.992	-11.37	≤ 3.00	Pass
0	1928.448	-12.04	≤ 3.00	Pass

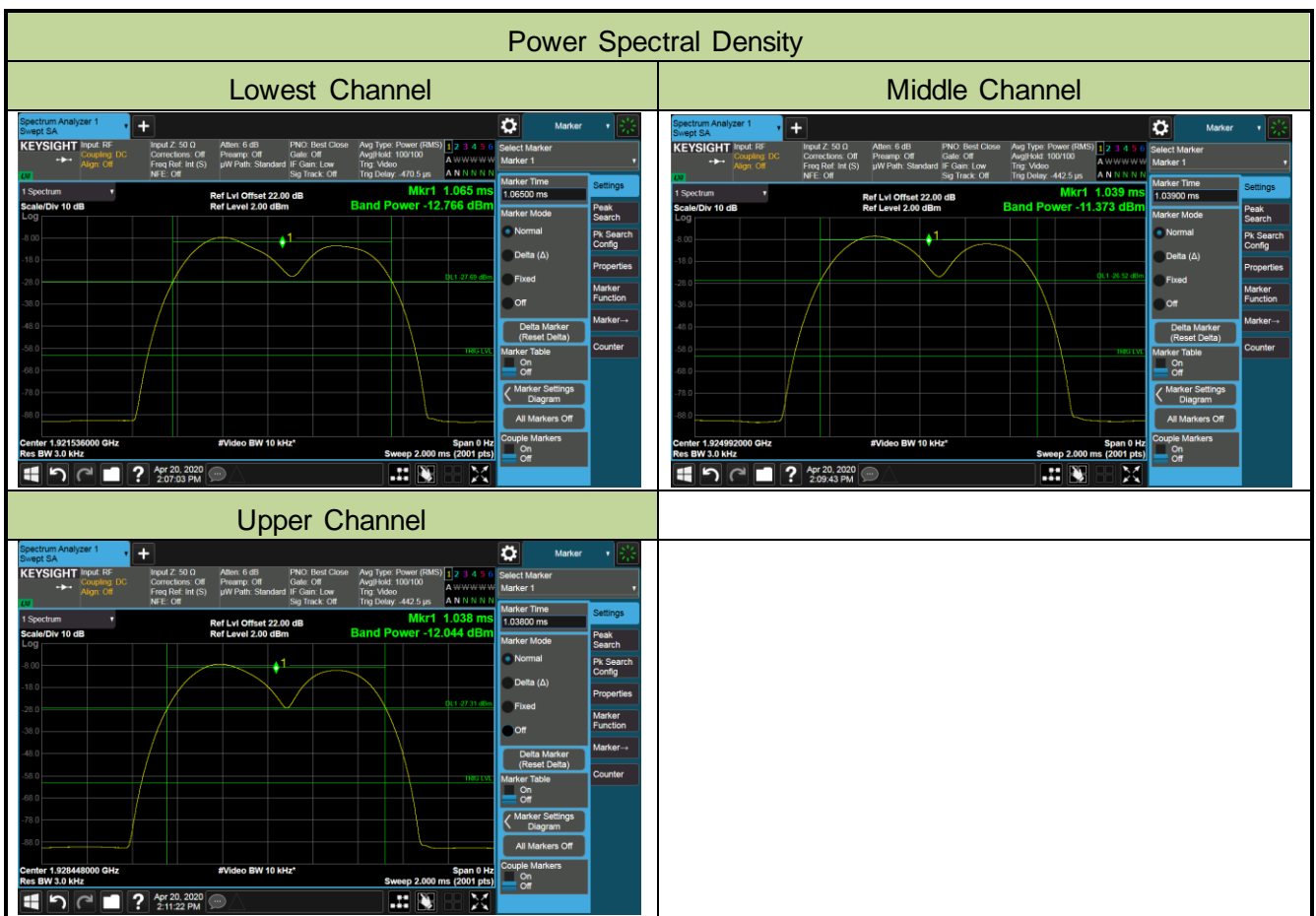

7.6. In-Band Unwanted Emissions

7.6.1. Test Limit

B < f2_2B: less than or equal to 30 dB below maximum permitted peak power level

2B < f2_3B: less than or equal to 50 dB below maximum permitted peak power level

3B < f2_UPCS Band Edge: less than or equal to 60 dB below maximum permitted peak power level.

7.6.2. Test Procedure Used

ANSI C63.17, Clause 6.1.6.1

7.6.3. Test Setup

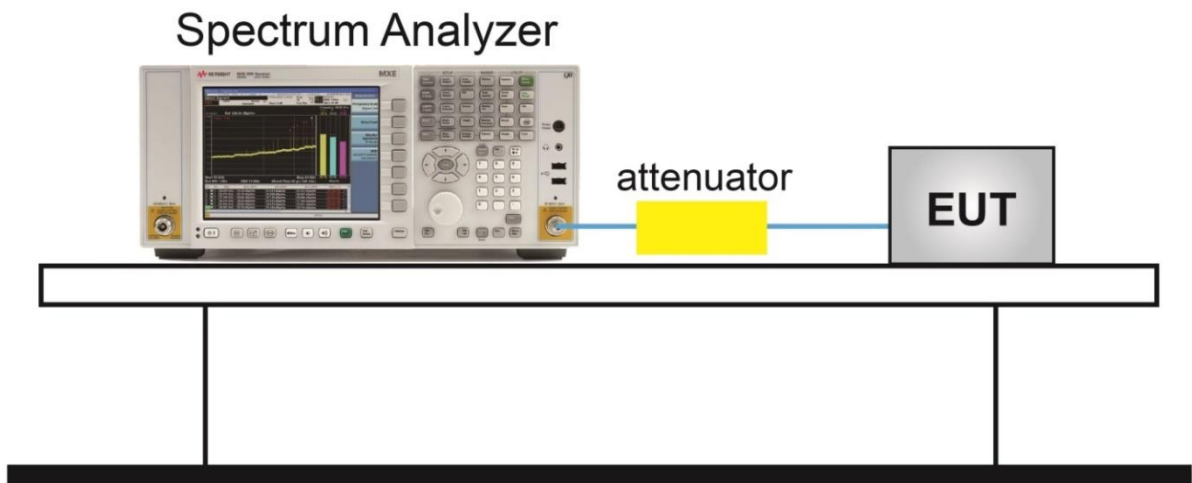

7.6.4. Test Result

Product	Keyfob	Temperature	25.0°C
Test Engineer	Dandy Li	Relative Humidity	64.0%
Test Site	TR3	Test Date	2020/04/20

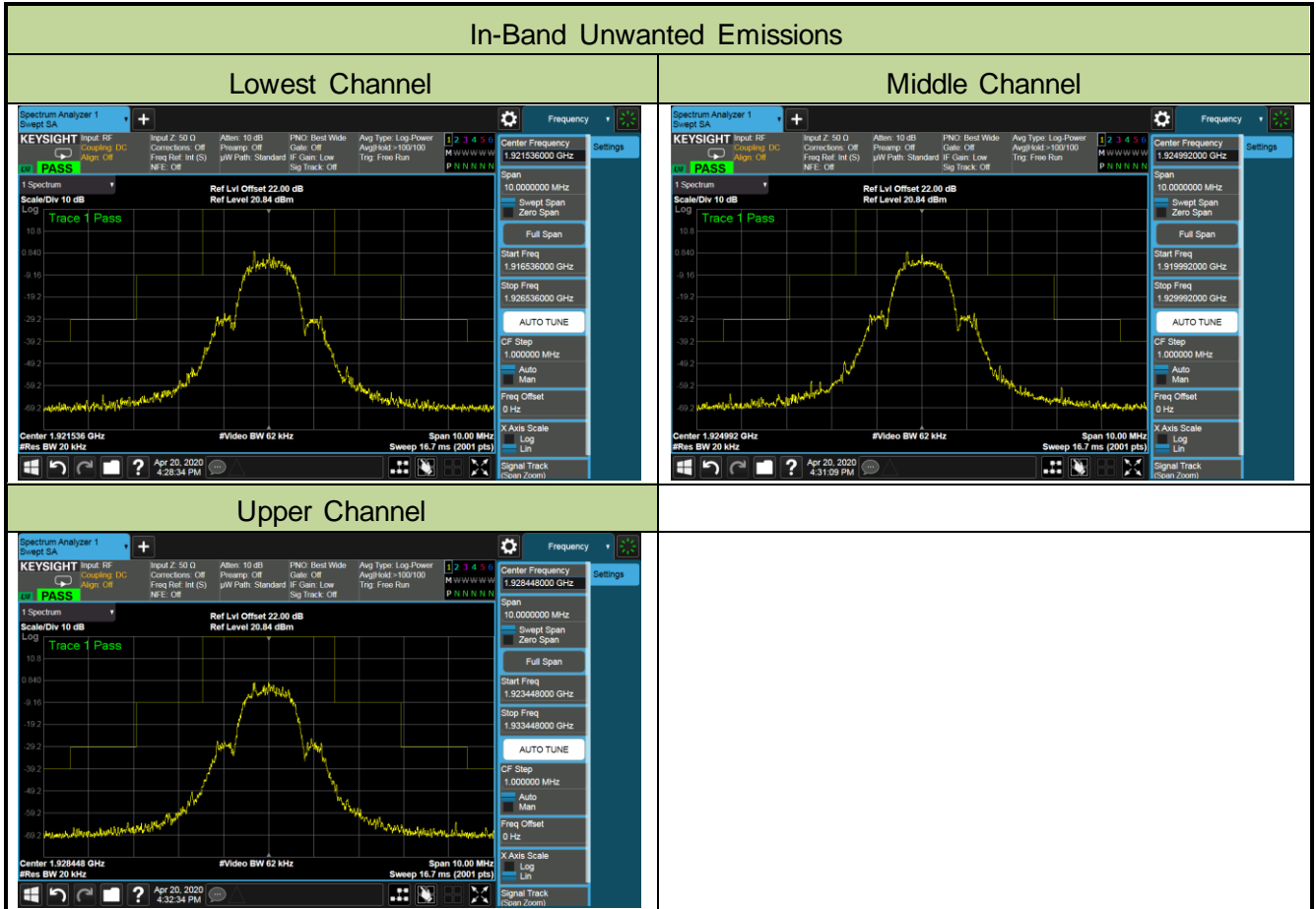

Note: The BS spurious in-band of Middle Channel transmission level is below the indicated limit.

7.7. Out-of-Band Emissions, Conducted

7.7.1. Test Limit

$f \leq 1.25$ MHz outside UPCS band: ≤ -9.5 dBm

1.25 MHz $\leq f \leq 2.5$ MHz outside UPCS band: ≤ -29.5 dBm

$f \leq 2.5$ MHz outside UPCS band: ≤ -39.5 dBm

7.7.2. Test Procedure Used

ANSI C63.17, Clause 6.1.6.2

7.7.3. Test Setup

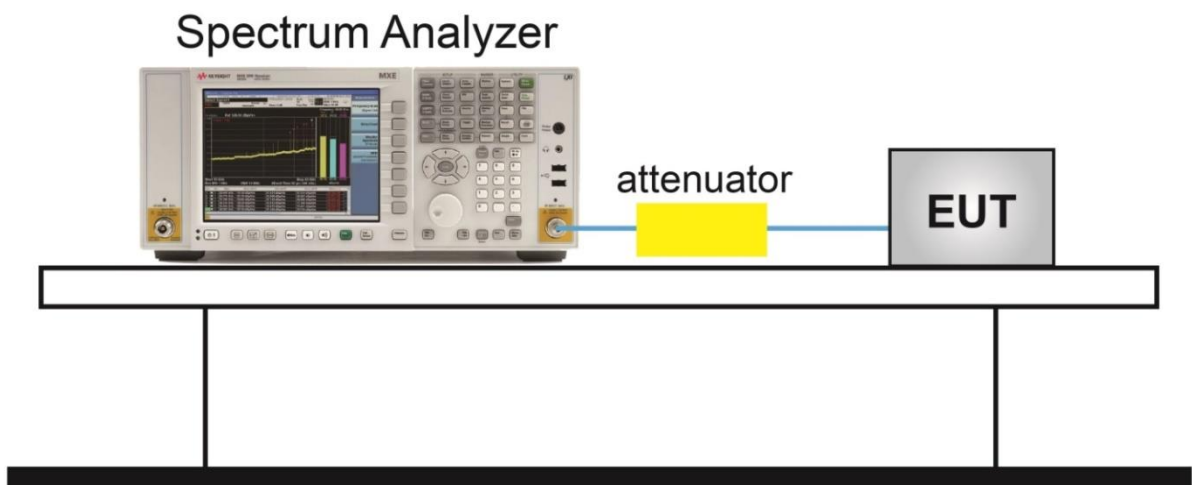

7.7.4. Test Result

Product	Keyfob	Temperature	25.0°C
Test Engineer	Dandy Li	Relative Humidity	64.0%
Test Site	TR3	Test Date	2020/04/20

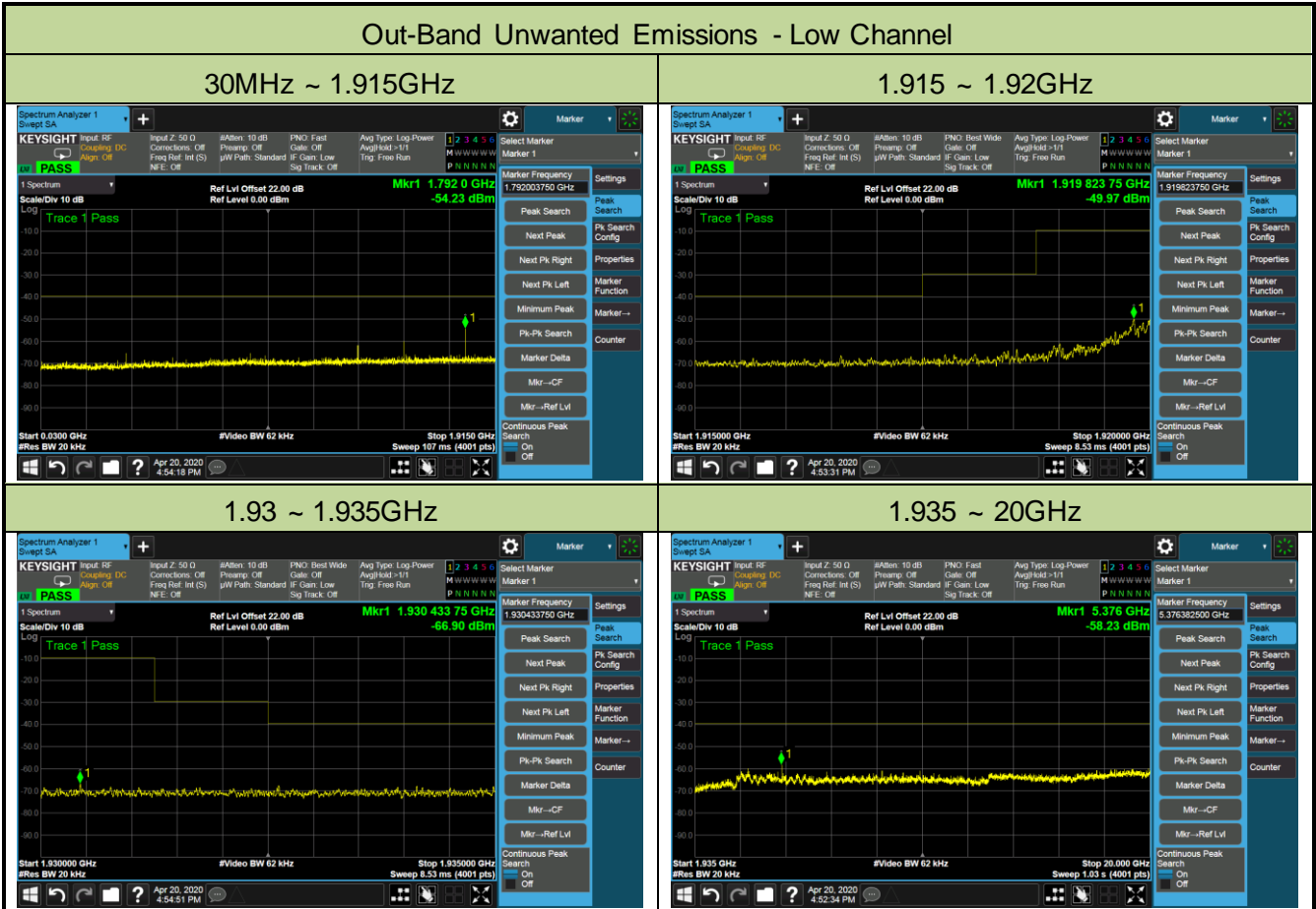

Out-Band Unwanted Emissions - Middle Channel

30MHz ~ 1.915GHz



1.915 ~ 1.92GHz

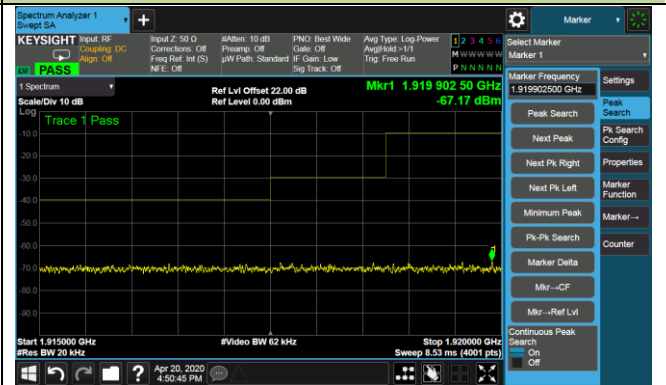

1.93 ~ 1.935GHz

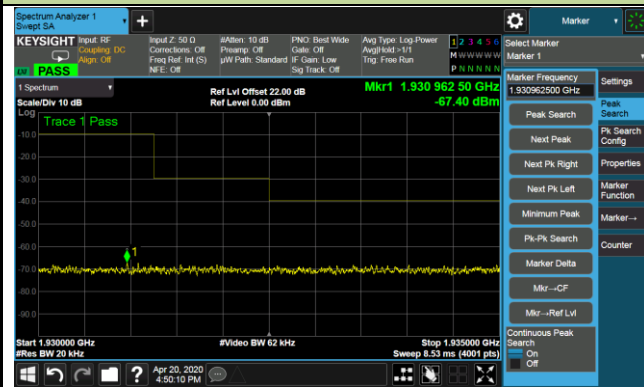

1.935 ~ 20GHz



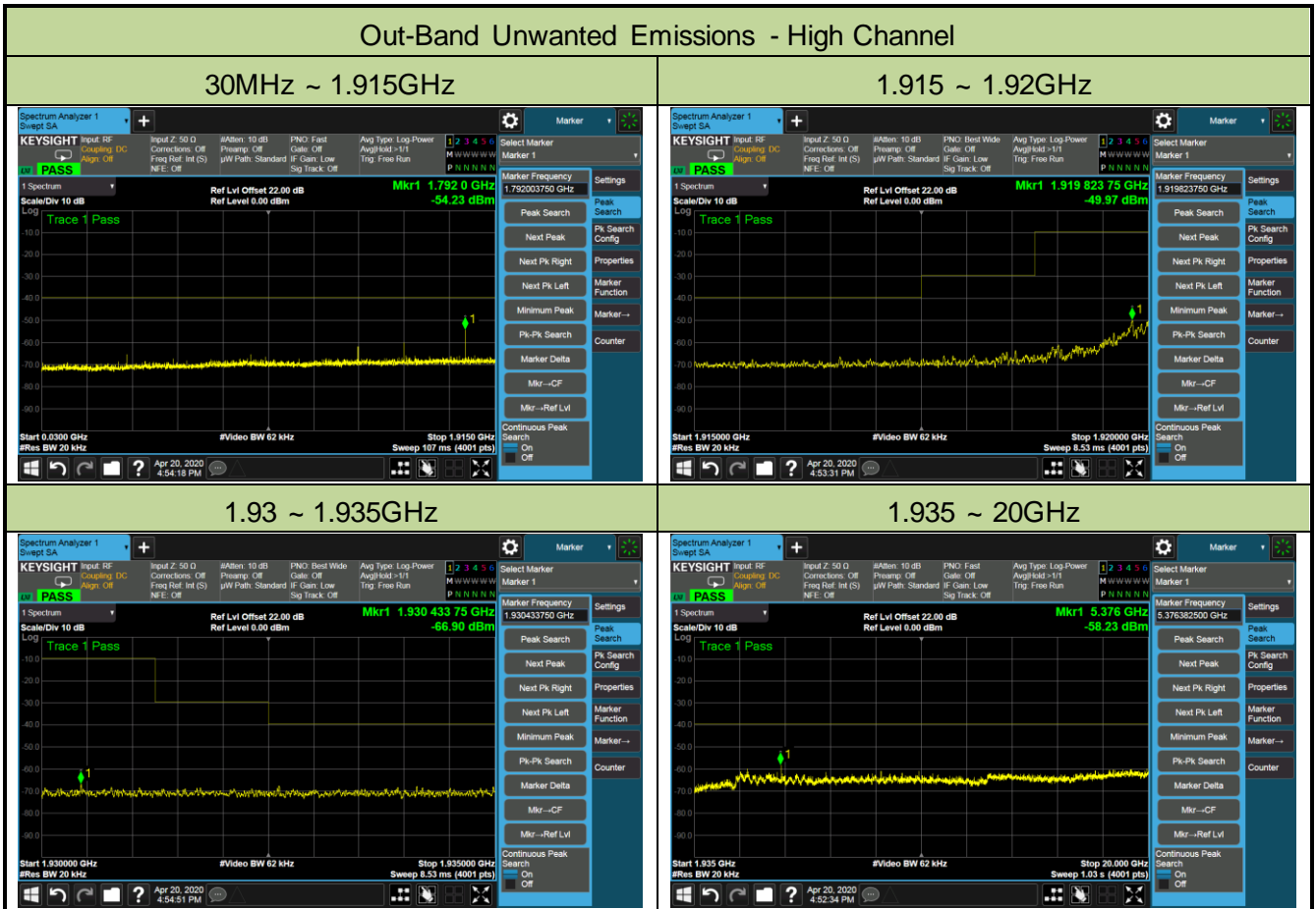

Note 1: The BS spurious out-of-band transmission level is below the indicated limit.

Note 2: During the test RTX's modulation type was PSBR.

7.8. Carrier Frequency Stability

7.8.1. Test Limit

Per §15.323(f), the frequency stability of the carrier frequency of the intentional radiator shall be maintained within ± 10 ppm over 1 hour or the interval between channel access monitoring, whichever is shorter. The frequency stability shall be maintained over a temperature variation of -20°C to $+50^{\circ}\text{C}$ at normal supply voltage, and over a variation in the primary supply voltage of 85 percent to 115 percent of the rated supply voltage at a temperature of 20°C . For equipment that is capable only of operating from a battery, the frequency stability tests shall be performed using a new battery without any further requirement to vary supply voltage.

7.8.2. Test Procedure Used

ANSI C63.17, Clause 6.2.1

7.8.3. Test Setup

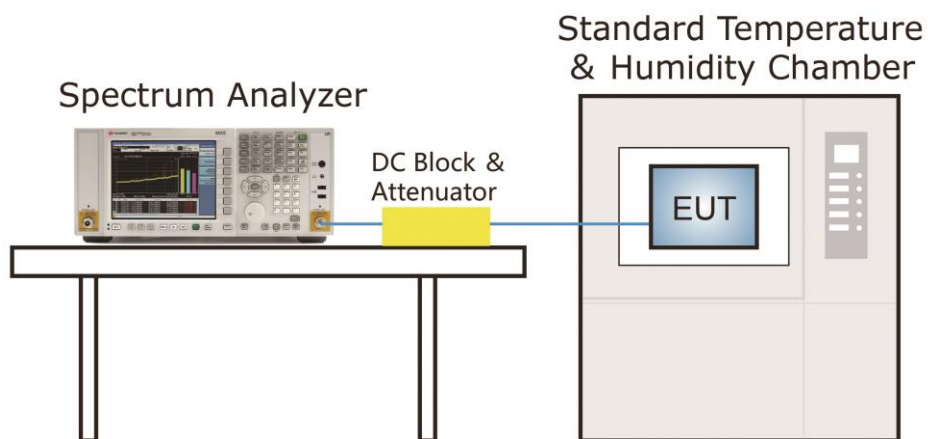

7.8.4. Test Result

The Frequency Stability is measured with the RTX. The RTX was logged by a computer programmed to get the new readings as fast as possible (about 3 readings per second) over the noted time period or number of readings. The peak-to-peak difference was recorded and the mean value and deviation in ppm was calculated.

The Carrier Frequency Stability over power Supply Voltage and over Temperature is measured also with the RTX.

Carrier Frequency Stability over Time at Nominal Temperature

Average Mean Carrier Frequency (MHz)	Max. Diff. (kHz)	Min. Diff. (kHz)	Max Dev. (ppm)	Limit (ppm)
1924.998143	9.1	0.2	4.6	±10

Note 1: Max Dev. (ppm) = [(Max. Diff. - Min. Diff.) / Average Mean Carrier Freq.] x 10⁶

Note 2: Deviation (ppm) is calculated from 3000 readings with the RTX.

Carrier Frequency Stability over Time at Nominal Temperature

Voltage	Measured Carrier Frequency (MHz)	Difference (kHz)	Deviation (ppm)	Limit (ppm)
Vnom	1924.9981	6.1	3.17	±10
85% of Vnom	1924.9997	7.7	4.00	
115% of Vnom	1924.9963	4.3	2.23	

Note 1: Difference (kHz) = Measured Carrier Freq. - Carrier Freq.

Note 2: Deviation (ppm) = [Difference (kHz) / Carrier Freq.] x 10⁶

Carrier Frequency Stability over Temperature

Voltage	Measured Carrier Frequency (MHz)	Difference (kHz)	Deviation (ppm)	Limit (ppm)
T = +20°C	1924.9941	Ref	Ref	±10
T = -20°C	1924.9967	2.6	1.3	
T = +50°C	1924.9942	1.0	0.5	

Note 1: Set the Measured Carrier Frequency (MHz) T = +20°C as Ref Level

Note 2: Difference (kHz) = Measured Carrier Freq. T = -20°C - Measured Carrier Freq. T = +20°C or Measured Carrier Freq. T = +50°C - Measured Carrier Freq. T = +20°C

Note 2: Deviation (ppm) = [Difference (kHz) / Carrier Freq.] x 10⁶.

7.9. Specific Requirements for UPCS Device

7.9.1. Monitoring Time Requirements

Immediately prior to initiating transmission, devices must monitor the combined time and spectrum window in which they intend to transmit. For a period of at least 10 milliseconds for systems designed to use a 10 milliseconds or shorter frame period or at least 20 milliseconds for systems designed to use a 20 milliseconds frame period

7.9.1.1. Test Procedure Used

ANSI C63.17, Clause 7.5

7.9.1.2. Test Setup

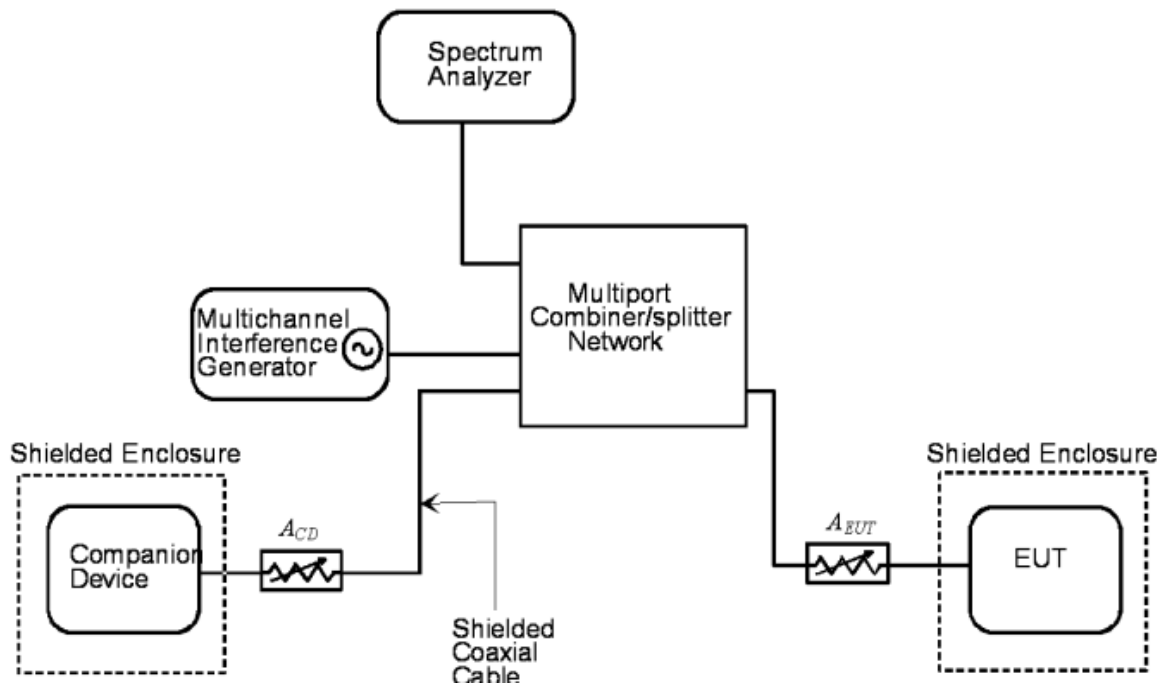

7.9.1.3. Test Result

Interference (Refer to ANSIC63.17 clause 7.3.4)	Reaction of EUT	Results
Apply the interference on f_1 at level TU+UM, and no interference on f_2 . Initiate transmission and verify the transmission on f_2 .	EUT transmits on f_2	Pass
Apply the interference on f_2 at level TU+UM, at the same time, no interference on f_1 . After about 20ms, initiate transmission and verify the transmission on f_1 .	EUT transmits on f_1	Pass

7.9.2. Lowest Monitoring Threshold Requirements

The monitoring threshold must not be more than 30 dB above the thermal noise power for a bandwidth equivalent to the emission bandwidth used by the device.

7.9.2.1. Test Procedure Used

ANSI C63.17, Clause 7.3.1

7.9.2.2. Test Result

Not Apply

7.9.3. Acknowledgements and Transmission Duration Requirements

Occupation of the same combined time and spectrum windows by a device or group of cooperating devices continuously over a period of time longer than 8 hours is not permitted without repeating the access criteria.

Once access to specific combined time and spectrum windows is obtained an acknowledgement from a system participant must be received by the initiating transmitter within one second or transmission must cease.

Periodic acknowledgements must be received at least every 30 seconds or transmission must cease.

Channels used exclusively for control and signaling information may transmit continuously for 30 seconds without receiving an acknowledgement, at which time the access criteria must be repeated.

7.9.3.1. Test Procedure Used

ANSI C63.17, Clause 8.2.1 & 8.2.2

7.9.3.2. Test Result

Test ref. to ANSI C63.17 clause 8.2.1	Observation	Verdict
Initial transmission without acknowledgements	Not applicable for EUT that transmits control and signaling information	N/A
Transmission time after loss of acknowledgements	10.0	Pass

Test ref. to ANSI C63.17 clause 8.2.2	Observation	Verdict
Transmission duration on same time and frequency window	Only for initiating device that controls which time slot is used	N/A

7.9.4. Least Interfered Channel (LIC) Selection Requirements

If access to spectrum is not available as determined by the above, and a minimum of 40 duplex system access channels are defined for the system, the time and spectrum windows with the lowest power level below a monitoring threshold of 50 dB above the thermal noise power determined for the emission bandwidth may be accessed.

Calculation of monitoring threshold limits for isochroous devices:

Lowest threshold: $TL = -174 + 10\log_{10}B + M_u + P_{MAX} - P_{EUT}(\text{dBm})$

Upper threshold: $TU = -174 + 10\log_{10}B + M_u + P_{MAX} - P_{EUT}(\text{dBm})$

Where: B=Emission bandwidth (Hz)

M_u =dB the threshold may exceed thermal noise (30 for T_L & 50 for T_U)

$P_{MAX} = 5 * \log_{10}B - 10(\text{dBm})$

P_{EUT} =Transmitted power (dBm)

Monitor Threshold	B (MHz)	M_u (dB)	P_{MAX} (dBm)	P_{EUT} (dBm)	Threshold (dBm)
TL	1.469	30	20.84	10.45	-71.94
TU	1.469	50	20.84	10.45	-51.94

The EUT must not transmit until the interference level is less than or equal to:

Measured Threshold Level $\leq TU$

Where: TU =Upper threshold level

7.9.4.1. Test Procedure Used

ANSI C63.17, Clause 7.3.2 & 7.3.3 & 7.3.4

7.9.4.2. Test Result

Monitor threshold	Measured Threshold Level	Limit (dBm)
Lowest Threshold (dBm)	N/A	-71.94
Upper Threshold (dBm)	N/A	-51.94

Note: N/A Not applicable - EUT which supports at least of 40 duplex system access channels and implements Least Interfered Channel (LIC) algorithm is permitted to use an upper monitoring threshold.

7.9.5. Random waiting Requirements

If the selected combined time and spectrum windows are unavailable, the device may either monitor and select different windows or seek to use the same window after waiting an amount of time, randomly chosen from a uniform random distribution between 10 and 150 milliseconds, commencing when the channel becomes available.

7.9.5.1. Test Procedure Used

ANSI C63.17, Clause 8.1.3

7.9.5.2. Test Result

The manufacturer declares that this provision is not utilized by the EUT

7.9.6. Monitoring Bandwidth Requirements

The monitoring system bandwidth must be equal to or greater than the emission bandwidth of the intended transmission and have a maximum reaction time less than $50 \times \text{SQRT}(1.25/\text{emission bandwidth in MHz})$ microseconds for signals at the applicable threshold level but shall not be required to be less than 50 microseconds

7.9.6.1. Test Procedure Used

ANSI C63.17, Clause 7.5

7.9.6.2. Test Result

Test Equation (μs)	B (MHz)	Pulse width(μs)	Limit (us)	Result
$50 (1.25/B)^{1/2}$	1.469	46.12	50	Pass
$25 (1.25/B)^{1/2}$	1.469	23.06	35	Pass

7.9.7. Monitoring Antenna Requirements

The monitoring system shall use the same antenna used for transmission, or an antenna that yields equivalent reception at that location.

7.9.7.1. Test Procedure Used

ANSI C63.17 paragraph 4

7.9.7.2. Test Result

The antenna of the EUT used for transmission is the same interior antenna that used for monitoring.

7.9.8. Monitoring Antenna Requirements

Devices that have a power output Lowest than the maximum permitted under the rules can increase their monitoring detection threshold by one decibel for each one decibel that the transmitter power is below the maximum permitted

7.9.8.1. Test Procedure Used

ANSI C63.17 paragraph 4

7.9.8.2. Test Result

Not apply

7.9.9. Dual Access Criteria Check Requirements

An initiating device may attempt to establish a duplex connection by monitors both its intended transmit and receive time and spectrum windows. If both the intended transmit and receive time and spectrum windows meet the access criteria, then the initiating device can initiate a transmission in the intended transmit time and spectrum window. If the power detected by the responding device can be decoded as a duplex connection signal from the initiating device, then the responding device may immediately begin transmitting on the receive time and spectrum window monitored by the initiating device.

7.9.9.1. Test Procedure Used

ANSI C63.17, Clause 8.3.1 & 8.3.2

7.9.9.2. Test Result

EUT do not implement the LIC procedure:

Test ref. to ANSI C63.17 clause 8.3.1	Observation	Verdict
b) EUT is restricted to a single carrier $f1$ for TDMA systems. The Test is Pass if EUT can transmit	EUT can transmit	Pass
c) d) Interference at level $T_L + U_M$ on all timeslots except one receive slot where interference is at least 10 dB below T_L	No connection possible	N/A
e) f) Interference at level $T_L + U_M$ on all timeslots except one transmit slot where interference is at least 10 dB below T_L	No connection possible	N/A

EUTs that implements the LIC procedure:

Test ref. to ANSI C63.17 clause 8.3.1	Observation	Verdict
b) EUT is restricted to a single carrier $f1$ for TDMA systems. The Test is Pass if EUT can transmit	EUT can transmit	Pass
c) d) Transmission on interference-free receive time/spectrum window	Connected on the target Rx window and its duplex mate.	Pass
e) f) Transmission on interference-free transmit time/spectrum window	Connected on the target Tx window and its duplex mate.	Pass

7.9.10. Alternative monitoring interval for co-located devices Requirements

An initiating device that is prevented from monitoring during its intended transmit window due to monitoring system blocking from the transmissions of a co-located (within one meter) transmitter of the same system, may monitor the portions of the time and spectrum windows in which they intend to receive over a period of at least 10 milliseconds. The monitored time and spectrum window must total at least 50 percent of the 10 millisecond frame interval and the monitored spectrum must be within 1.25 MHz of the center frequency of channel(s) already occupied by that device or co-located co-operating devices. If the access criteria is met for the intended receive time and spectrum window under the above conditions, then transmission in the intended transmit window by the initiating device may commence.

7.9.10.1. Test Procedure Used

ANSI C63.17, Clause 8.4

7.9.10.2. Test Result

The manufacturer declares that this provision is not utilized by the EUT.

7.9.11. Frame Repetition Stability and Period and Jitter

7.9.11.1. Test Limit

The frame period (a set of consecutive time slots in which the position of each time slot can be identified by reference to a synchronizing source) of an intentional radiator operating in this band shall be 20 milliseconds or 10 milliseconds/X where X is a positive whole number. Each device that implements time division for the purposes of maintaining a duplex connection on a given frequency carrier shall maintain a frame repetition rate with a frequency stability of at least 50 parts per million (ppm). Each device which further divides access in time in order to support multiple communication links on a given frequency carrier shall maintain a frame repetition rate with a frequency stability of at least 10 ppm. The jitter (time-related, abrupt, spurious variations in the duration of the frame interval) introduced at the two ends of such a communication link shall not exceed 25 microseconds for any two consecutive transmissions. Transmissions shall be continuous in every time and spectrum window during the frame period defined for the device.

7.9.11.2. Test Procedure Used

ANSI C63.17, Clause 6.2.2 & 6.2.3

7.9.11.3. Test Setup

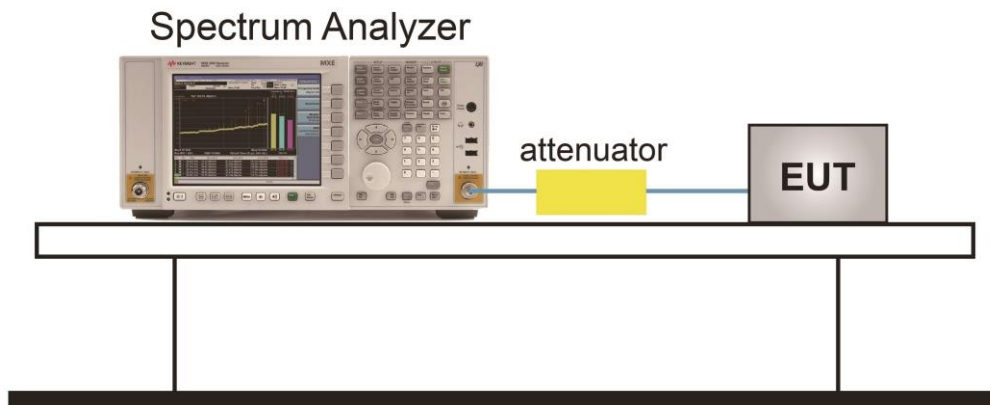

7.9.11.4. Test Result

Carrier Frequency (MHz)	Frame Jitter (us)					Limit of Δ
	min	mean	max	Δ min	Δ max	
1924.992	-0.89	0	0.91	-0.89	0.91	± 25

8. CONCLUSION

The data collected relate only the item(s) tested and show that the unit is compliance with Part 15D of the FCC Rules.

The End

Appendix A - Test Setup Photograph

Refer to “2004RSU031-UT” file.

Appendix B - EUT Photograph

Refer to "2004RSU031-UE" file.