



**FCC 47 CFR PART 15 SUBPART C**

**TEST REPORT**

**For**

**Wireless Network Camera**

**Model: RC832xxxxxxxxx**  
**(x=0 to 9, A to Z, blank or “-“ for marking purpose)**

**Trade Name: SerComm; AT&T; iControl; ADT**

*Issued to*

**SerComm Corporation**  
**8F, No.3-1, YuanQuSt., NanKang, Taipei115, Taiwan, R.O.C.**

*Issued by*

**Compliance Certification Services Inc.**  
**No.81-1, Lane 210, Bade 2nd Rd., Lujhu Township,**  
**Taoyuan County 33841, Taiwan, R.O.C.**  
**TEL: 886-3-324-0332**  
**FAX: 886-3-324-5235**  
**<http://www.ccsrf.com>**  
**[service@ccsrf.com](mailto:service@ccsrf.com)**



**Note:** *This report shall not be reproduced except in full, without the written approval of Compliance Certification Services Inc. This document may be altered or revised by Compliance Certification Services Inc. personnel only, and shall be noted in the revision section of the document. The client should not use it to claim product endorsement by TAF, A2LA, NIST or any government agencies. The test results in the report only apply to the tested sample.*



**Revision History**

Rev.	Issue Date	Revisions	Effect Page	Revised By
00	October 24, 2013	Initial Issue	All	Angel Hu



## TABLE OF CONTENTS

<b>1. TEST RESULT CERTIFICATION .....</b>	<b>4</b>
<b>2. EUT DESCRIPTION.....</b>	<b>5</b>
<b>3. TEST METHODOLOGY.....</b>	<b>6</b>
3.1 EUT CONFIGURATION .....	6
3.2 EUT EXERCISE .....	6
3.3 GENERAL TEST PROCEDURES.....	6
3.4 FCC PART 15.205 RESTRICTED BANDS OF OPERATIONS .....	7
3.5 DESCRIPTION OF TEST MODES.....	8
<b>4. INSTRUMENT CALIBRATION .....</b>	<b>9</b>
4.1 MEASURING INSTRUMENT CALIBRATION .....	9
4.2 MEASUREMENT EQUIPMENT USED .....	9
4.3 MEASUREMENT UNCERTAINTY .....	10
<b>5. FACILITIES AND ACCREDITATIONS .....</b>	<b>11</b>
5.1 FACILTIES .....	11
5.2 EQUIPMENT .....	11
5.3 TABLE OF ACCREDITATIONS AND LISTINGS.....	12
<b>6. SETUP OF EQUIPMENT UNDER TEST .....</b>	<b>13</b>
6.1 SETUP CONFIGURATION OF EUT .....	13
6.2 SUPPORT EQUIPMENT.....	13
<b>7. FCC PART 15.247 REQUIREMENTS .....</b>	<b>14</b>
7.1 6dB BANDWIDTH .....	14
7.2 PEAK POWER .....	25
7.3 AVERAGE POWER .....	27
7.4 BAND EDGES MEASUREMENT .....	29
7.5 PEAK POWER SPECTRAL DENSITY .....	46
7.6 SPURIOUS EMISSIONS.....	57
7.7 POWERLINE CONDUCTED EMISSIONS .....	89
<b>APPENDIX I PHOTOGRAPHS OF TEST SETUP .....</b>	<b>92</b>
<b>APPENDIX I PHOTOGRAPHS OF TEST SETUP .....</b>	<b>92</b>



# 1. TEST RESULT CERTIFICATION

**Applicant:** SerComm Corporation  
8F, No. 3-1, YuanQu St., NanKang, Taipei 115, Taiwan, R.O.C.

**Manufacturer:** SerComm Corporation  
8F, No. 3-1, YuanQu St., NanKang, Taipei 115, Taiwan, R.O.C.

**Equipment Under Test:** Wireless Network Camera

**Trade Name:** SerComm; AT&T; iControl; ADT

**Model:** RC832xxxxxxxxx  
(x=0 to 9, A to Z, blank or "-" for marking purpose)

**Date of Test:** October 3 ~ 22, 2013

APPLICABLE STANDARDS	
STANDARD	TEST RESULT
FCC 47 CFR Part 15 Subpart C	No non-compliance noted

### We hereby certify that:

The above equipment was tested by Compliance Certification Services Inc. The test data, data evaluation, test procedures, and equipment configurations shown in this report were made in accordance with the procedures given in ANSI C63.4 and the energy emitted by the sample EUT tested as described in this report is in compliance with the requirements of FCC Rules Part 15.207, 15.209, 15.247.

The test results of this report relate only to the tested sample EUT identified in this report.

**Approved by:**

**Reviewed by:**

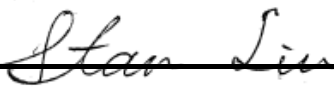
  
 \_\_\_\_\_  
 Stan Lin  
 Section Manager

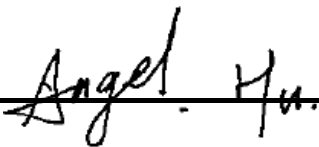
  
 \_\_\_\_\_  
 Angel Hu  
 Section Manager



## 2. EUT DESCRIPTION

<b>Product</b>	Wireless Network Camera		
<b>Trade Name</b>	SerComm; AT&T; iControl; ADT		
<b>Model Number</b>	RC832xxxxxxxx(x=0 to 9, A to Z, blank or "-" for marking purpose)		
<b>Model Discrepancy</b>	<ol style="list-style-type: none"> <li>1. The mean of "x" (x=0 to 9, A to Z, blank or "-" for marking purpose)" on model number just for marketing purpose only.</li> <li>2. Client consigns only one model sample to test (model number: RC8321). Therefore, the testing Lab. just guarantees the unit, which has been tested.</li> <li>3. According to customer declaration, the EUT have two types for sale, all specification and layout are identical, except of appearance. (Please refer external photograph)</li> </ol>		
<b>EUT Power Rating</b>	12VDC, 1A		
<b>Power Adapter Manufacturer</b>	APD	<b>Model</b>	WA-12M12FU
<b>Power Adapter Power Rating</b>	I/P: 100-240VAC, 50-60Hz, 0.5A O/P: 12VDC, 1A		
<b>RF Module Manufacturer</b>	MTK	<b>Model</b>	MT7620N
<b>Operating Frequency Range</b>	IEEE 802.11 b/g/HT20 mode: 2412 ~ 2462 MHz IEEE 802.11 HT40 mode: 2422 ~ 2452 MHz		
<b>Transmit Power</b>	IEEE 802.11b mode: 20.71dBm (0.1178 W) IEEE 802.11g mode: 23.28dBm (0.2128W) IEEE 802.11n HT20 mode: 24.70dBm (0.2953W) IEEE 802.11n HT40 mode: 23.97dBm (0.2493W)		
<b>Modulation Technique</b>	IEEE 802.11b mode: DSSS (1, 2, 5.5 and 11 Mbps) IEEE 802.11g mode: OFDM (6, 9, 12, 18, 24, 36, 48 and 54 Mbps) IEEE 802.11n HT20 mode: OFDM (6.5, 7.2, 13, 14.4, 14.44, 19.5, 21.7, 26, 28.89, 28.9, 39, 43.3, 43.33 52, 57.78, 57.8, 58.5, 65.0, 72.2, 78, 86.67, 104, 115.56, 117, 130, 144.44 Mbps) IEEE 802.11n HT40 mode: OFDM (13.5, 15, 27, 30, 40.5, 45, 54, 60, 81, 90, 108, 120, 121.5, 135, 150, 162, 180, 216, 240, 243, 270, 300 Mbps)		
<b>Number of Channels</b>	IEEE 802.11b/g mode: 11 Channels IEEE 802.11n HT20 mode: 11 Channels IEEE 802.11n HT40 mode: 7 Channels		
<b>Antenna Specification</b>	Type A: ANT 0: PIFA Antenna / Gain: 4.31dBi; ANT 1: PIFA Antenna / Gain: 3.54dBi (MIMO: $10\log[(10^{4.31/20} + 10^{3.54/20})/2] = 6.94$ ) Type B: ANT 0: PIFA Antenna / Gain: 3.04dBi; ANT 1: PIFA Antenna / Gain: 2.62dBi (MIMO: $10\log[(10^{3.04/20} + 10^{2.62/20})/2] = 5.84$ )		

**Remark:**

1. The sample selected for test was production product and was provided by manufacturer.
2. This submittal(s) (test report) is intended for FCC ID: **P27RC8321** filing to comply with Section 15.207, 15.209 and 15.247 of the FCC Part 15, Subpart C Rules.



### **3. TEST METHODOLOGY**

The tests documented in this report were performed in accordance with ANSI C63.4 and FCC CFR 47 Part 2, Part 15.207, 15.209 and 15.247.

#### **3.1 EUT CONFIGURATION**

The EUT configuration for testing is installed on RF field strength measurement to meet the Commissions requirement and operating in a manner that intends to maximize its emission characteristics in a continuous normal application.

#### **3.2 EUT EXERCISE**

The EUT was operated in the engineering mode to fix the TX frequency that was for the purpose of the measurements.

According to its specifications, the EUT must comply with the requirements of the Section 15.207, 15.209 and 15.247 under the FCC Rules Part 15 Subpart C.

#### **3.3 GENERAL TEST PROCEDURES**

##### **Conducted Emissions**

The EUT is placed on the turntable, which is 0.8 m above ground plane. According to the requirements in Section 13.1.4.1 of ANSI C63.4 Conducted emissions from the EUT measured in the frequency range between 0.15 MHz and 30MHz using CISPR Quasi-peak and average detector modes.

##### **Radiated Emissions**

The EUT is placed on a turn table, which is 0.8 m above ground plane. The turntable shall rotate 360 degrees to determine the position of maximum emission level. EUT is set 3m away from the receiving antenna, which varied from 1m to 4m to find out the highest emission. And also, each emission was to be maximized by changing the polarization of receiving antenna both horizontal and vertical. In order to find out the maximum emissions, exploratory radiated emission measurements were made according to the requirements in Section 13.1.4.1 of ANSI C63.4.



### 3.4 FCC PART 15.205 RESTRICTED BANDS OF OPERATIONS

(a) Except as shown in paragraph (d) of this section, only spurious emissions are permitted in any of the frequency bands listed below:

MHz	MHz	MHz	GHz
0.090 - 0.110	16.42 - 16.423	399.9 - 410	4.5 - 5.15
<sup>1</sup> 0.495 - 0.505	16.69475 - 16.69525	608 - 614	5.35 - 5.46
2.1735 - 2.1905	16.80425 - 16.80475	960 - 1240	7.25 - 7.75
4.125 - 4.128	25.5 - 25.67	1300 - 1427	8.025 - 8.5
4.17725 - 4.17775	37.5 - 38.25	1435 - 1626.5	9.0 - 9.2
4.20725 - 4.20775	73 - 74.6	1645.5 - 1646.5	9.3 - 9.5
6.215 - 6.218	74.8 - 75.2	1660 - 1710	10.6 - 12.7
6.26775 - 6.26825	108 - 121.94	1718.8 - 1722.2	13.25 - 13.4
6.31175 - 6.31225	123 - 138	2200 - 2300	14.47 - 14.5
8.291 - 8.294	149.9 - 150.05	2310 - 2390	15.35 - 16.2
8.362 - 8.366	156.52475 -	2483.5 - 2500	17.7 - 21.4
8.37625 - 8.38675	156.52525	2655 - 2900	22.01 - 23.12
8.41425 - 8.41475	156.7 - 156.9	3260 - 3267	23.6 - 24.0
12.29 - 12.293	162.0125 - 167.17	3332 - 3339	31.2 - 31.8
12.51975 - 12.52025	167.72 - 173.2	3345.8 - 3358	36.43 - 36.5
12.57675 - 12.57725	240 - 285	3600 - 4400	( <sup>2</sup> )
13.36 - 13.41	322 - 335.4		

<sup>1</sup> Until February 1, 1999, this restricted band shall be 0.490-0.510 MHz.

<sup>2</sup> Above 38.6

(b) Except as provided in paragraphs (d) and (e), the field strength of emissions appearing within these frequency bands shall not exceed the limits shown in Section 15.209. At frequencies equal to or less than 1000 MHz, compliance with the limits in Section 15.209 shall be demonstrated using measurement instrumentation employing a CISPR quasi-peak detector. Above 1000 MHz, compliance with the emission limits in Section 15.209 shall be demonstrated based on the average value of the measured emissions. The provisions in Section 15.35 apply to these measurements.



### **3.5 DESCRIPTION OF TEST MODES**

The EUT is a 2Tx2R MIMO transmitter.

Software used to control the EUT for staying in continuous transmitting mode was programmed.

The worst case data rate is determined as the data rate with highest output power.

After verification, all tests were carried out with the worst case test modes as shown below except radiated spurious emission below 1GHz, which worst case was in normal link mode only.

The field strength of spurious emission was measured in the following position: EUT stand-up position (Y axis), lie-down position (X, Z axis). The worst emission was found in lie-down position (X axis) and the worst case was recorded.

#### **IEEE 802.11b:**

Channel Low (2412MHz), Channel Mid (2437MHz) and Channel High (2462MHz) with 1Mbps data rate was chosen for full testing.

#### **IEEE 802.11g:**

Channel Low (2412MHz), Channel Mid (2437MHz) and Channel High (2462MHz) with 6Mbps data rate was chosen for full testing.

#### **IEEE 802.11n HT20:**

Channel Low (2412MHz), Channel Mid (2437MHz) and Channel High (2462MHz) with 6.5Mbps data rate were chosen for full testing.

#### **IEEE 802.11n HT40:**

Channel Low (2422MHz), Channel Mid (2437MHz) and Channel High (2452MHz) with 13.5Mbps data rate were chosen for full testing.





## 4. INSTRUMENT CALIBRATION

### 4.1 MEASURING INSTRUMENT CALIBRATION

The measuring equipment, which was utilized in performing the tests documented herein, has been calibrated in accordance with the manufacturer's recommendations for utilizing calibration equipment, which is traceable to recognized national standards.

### 4.2 MEASUREMENT EQUIPMENT USED

#### Equipment Used for Emissions Measurement

Conducted Emissions Test Site				
Name of Equipment	Manufacturer	Model	Serial Number	Calibration Due
Spectrum Analyzer	Agilent	E4446A	MY48250064	01/13/2014
Spectrum Analyzer	Agilent	N9010A	MY52220817	02/22/2014
Power meter	Anritsu	ML2495A	1033009	09/29/2014
Power Sensor	Anritsu	MA2411B	0917221	09/29/2014

3M Semi Anechoic Chamber				
Name of Equipment	Manufacturer	Model	Serial Number	Calibration Due
Spectrum Analyzer	Agilent	E4446A	MY48250064	01/13/2014
Pre-Amplifier	HP	8447D	2944A06530	04/23/2014
Pre-Amplifier	EMEC	EM01M26G	060570	07/25/2014
Pre-Amplifier	MITEQ	AMF-6F-260400-4 0-8P	985646	08/08/2014
Pre-Amplifier	Agilent	8449B	3008A01738	04/23/2014
EMI Test Receiver	SCHAFFNER	SCR 3501	430	03/24/2014
Loop Antenna	EMCO	6502	2356	06/12/2014
Bilog Antenna	TESEQ	CBL 6112D	35378	09/11/2014
Horn Antenna	EMCO	3115	00022250	08/04/2014
Horn Antenna	EMCO	3116	00026370	01/07/2014
Antenna Tower	CCS	CC-A-1F	N/A	N.C.R
Turn Table	CCS	CC-T-1F	N/A	N.C.R
Test S/W	EZ-EMC			

**Remark:** Each piece of equipment is scheduled for calibration once a year.



Power line Conducted Emissions Test Site				
Name of Equipment	Manufacturer	Model	Serial Number	Calibration Due
EMI Test Receiver	R&S	ESCI	101338	01/22/2014
LISN	R&S	ENV216	101549	07/29/2014
LISN	FCC	FCC-LISN-50/250-16-2-07	06012	12/11/2013
Test S/W	EZ-EMC			

**Remark:** Each piece of equipment is scheduled for calibration once a year.

### 4.3 MEASUREMENT UNCERTAINTY

Parameter	Uncertainty
Powerline Conducted Emission	±0.8191
3M Semi Anechoic Chamber / 30MHz ~ 200MHz	±3.5921
3M Semi Anechoic Chamber / 200MHz ~ 1GHz	±3.5657
3M Semi Anechoic Chamber / 1 ~ 8GHz	±2.5873
3M Semi Anechoic Chamber / 8 ~ 18GHz	±2.6646
3M Semi Anechoic Chamber / 18 ~ 26GHz	±2.9617
3M Semi Anechoic Chamber / 26 ~ 40GHz	±3.4250

**Remark:** This uncertainty represents an expanded uncertainty expressed at approximately the 95% confidence level using a coverage factor of k=2.



## **5. FACILITIES AND ACCREDITATIONS**

### **5.1 FACILITIES**

All measurement facilities used to collect the measurement data are located at

No. 163-1, Jhongsheng Rd., Sindien District, Taipei City 23151, Taiwan

No 11, Wugong 6th Rd, Wugu District, New Taipei City 24891, Taiwan (R.O.C)

Tel: 886-2-2299-9720 / Fax: 886-2-2298-4045

No.81-1, Lane 210, Bade 2nd Rd., Lujhu Township, Taoyuan County 33841, Taiwan, R.O.C.

Tel: 886-3-324-0332 / Fax: 886-3-324-5235

The sites are constructed in conformance with the requirements of ANSI C63.7, ANSI C63.4 and CISPR Publication 22.

### **5.2 EQUIPMENT**

Radiated emissions are measured with one or more of the following types of linearly polarized antennas: tuned dipole, biconical, log periodic, bi-log, and/or ridged waveguide, horn. Spectrum analyzers with pre-selectors and quasi-peak detectors are used to perform radiated measurements.





Conducted emissions are measured with Line Impedance Stabilization Networks and EMI Test Receivers.

Calibrated wideband preamplifiers, coaxial cables, and coaxial attenuators are also used for making measurements.

All receiving equipment conforms to CISPR Publication 16-1, "Radio Interference Measuring Apparatus and Measurement Methods."



### 5.3 TABLE OF ACCREDITATIONS AND LISTINGS

Country	Agency	Scope of Accreditation	Logo
USA	A2LA	CFR 47, FCC Part15/18, CISPR 22, EN 55022, ICES-003, AS/NZS CISPR 22, VCCI V-3, EN 55011, CISPR 11, IEC/EN 61000-4-2/3/4/5/6/8/11, EN 61000-6-1/2/3/4, EN 55024, CISPR 24, AS/NZS CISPR 24, AS/NZS 61000.6.2, EN 55014-1/-2, ETSI EN 300 386 v1.3.2/v1.3.3, IEC/EN 61000-3-2, AS/NZS 61000.3.2, IEC/EN 61000-3-3, AS/NZS 61000.3.3	 TESTING CERT #0824.01
USA	FCC MRA	3 meter Open Area Test Sites to perform FCC Part 15/18 measurements	
Japan	VCCI	3/10 meter Open Area Test Sites and conducted test sites to perform radiated/conducted measurements	<b>VCCI</b> R-2882/2541/2798/725/1868 C-402/747/912 T-1930/1646
Taiwan	TAF	EN 55014-1, CISPR 14, CNS 13781-1, EN 55013, CISPR 13, CNS 13439, EN 55011, CISPR 11, CNS 13803, PLMN09, IS2045-0, LP0002 FCC Part 27/90, Part 15B/C/D/E, RSS-192/193/210/310 ETSI EN 300 328/ 300 220-1/ 300 220-2/ 301 893/ 301 489-01/ 301 489-03/ 301 489-07 / 301 489-17/ 300 440-1/ 300 440-2 AS/NZS 4268, AS/NZS 4771 CISPR 22, EN 55022, CNS 13438, AS/NZS CISPR 22, VCCI, IEC/EN 61000-4-2/3/4/5/6/8/11, CNS 14676-2/3/4/5/6/8, CNS 14934-2/3, CNS 13783-1, CNS 13439, CNS 13803	
Taiwan	BSMI	CNS 13438, CNS 13783-1, CNS 13439, CNS 14115	SL2-IS-E-0014 / IN-E-0014 /A1-E-0014 /R1-E-0014 /R2-E-0014 /L1-E-0014
Canada	Industry Canada	RSS-Gen Issue 3	

**Note:** No part of this report may be used to claim or imply product endorsement by A2LA, TAF or other government agency.



## 6. SETUP OF EQUIPMENT UNDER TEST

### 6.1 SETUP CONFIGURATION OF EUT

See test photographs attached in Appendix 1 for the actual connections between EUT and support equipment.

### 6.2 SUPPORT EQUIPMENT

No.	Device Type	Model	Series No.	FCC ID	Brand	Data Cable	Power Cord
1	Notebook PC	S7110	DU4A00EG09 44P010	FCC DOC	Fujitsu	LAN Cable: Unshielded, 10m	AC I/P: Unshielded, 1.8m DC O/P: Unshielded, 1.8m with a core

**Remark:** Grounding was established in accordance with the manufacturer's requirements and conditions for the intended use.



## **7. FCC PART 15.247 REQUIREMENTS**

### **7.1 6dB BANDWIDTH**

#### **LIMIT**

According to §15.247(a)(2), systems using digital modulation techniques may operate in the 902 - 928 MHz, 2400 - 2483.5 MHz, and 5725 - 5850 MHz bands. The minimum 6 dB bandwidth shall be at least 500 kHz.

#### **TEST CONFIGURATION**

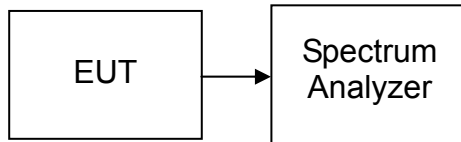

#### **TEST PROCEDURE**

1. Place the EUT on the table and set it in the transmitting mode.
2. Remove the antenna from the EUT and then connect a low loss RF cable from the antenna port to the spectrum analyzer.
3. Set the spectrum analyzer as RBW = 100kHz, VBW = 300kHz, Sweep = auto, Span = 30MHz (IEEE 802.11b, IEEE 802.11g, IEEE 802.11n HT20) or Span = 50MHz (IEEE 802.11n HT40).
4. Mark the peak frequency and -6dB (upper and lower) frequency.
5. Repeat until all the rest channels are investigated.

#### **TEST RESULTS**

*No non-compliance noted*



**TEST DATA**

**Test mode: IEEE 802.11b mode**

Channel	Frequency (MHz)	Bandwidth (MHz)	Limit (kHz)	Result
Low	2412	14.20	>500	PASS
Mid	2437	14.20		PASS
High	2462	14.20		PASS

**Test mode: IEEE 802.11g mode**

Channel	Frequency (MHz)	Bandwidth (MHz)	Limit (kHz)	Result
Low	2412	17.80	>500	PASS
Mid	2437	17.80		PASS
High	2462	17.80		PASS

**Test mode: IEEE 802.11n HT20 mode**

Channel	Frequency (MHz)	Bandwidth (MHz)		Limit (kHz)	Result
		Chain 0	Chain 1		
Low	2412	18.60	18.50	>500	PASS
Mid	2437	18.60	18.50		PASS
High	2462	18.55	18.50		PASS

**Test mode: IEEE 802.11n HT40 mode**

Channel	Frequency (MHz)	Bandwidth (MHz)		Limit (kHz)	Result
		Chain 0	Chain 1		
Low	2422	37.58	37.67	>500	PASS
Mid	2437	37.50	37.67		PASS
High	2452	37.50	37.65		PASS



### Test Plot

#### IEEE 802.11b mode

#### 6dB Bandwidth (CH Low)

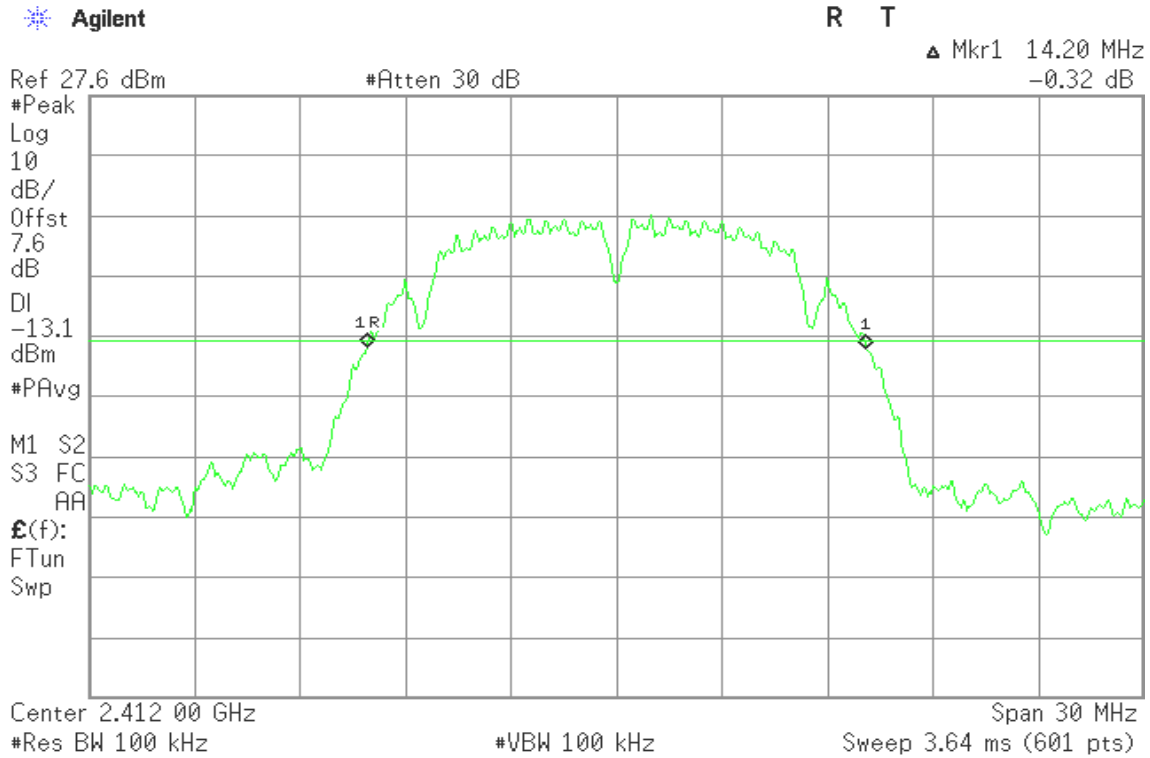

#### 6dB Bandwidth (CH Mid)

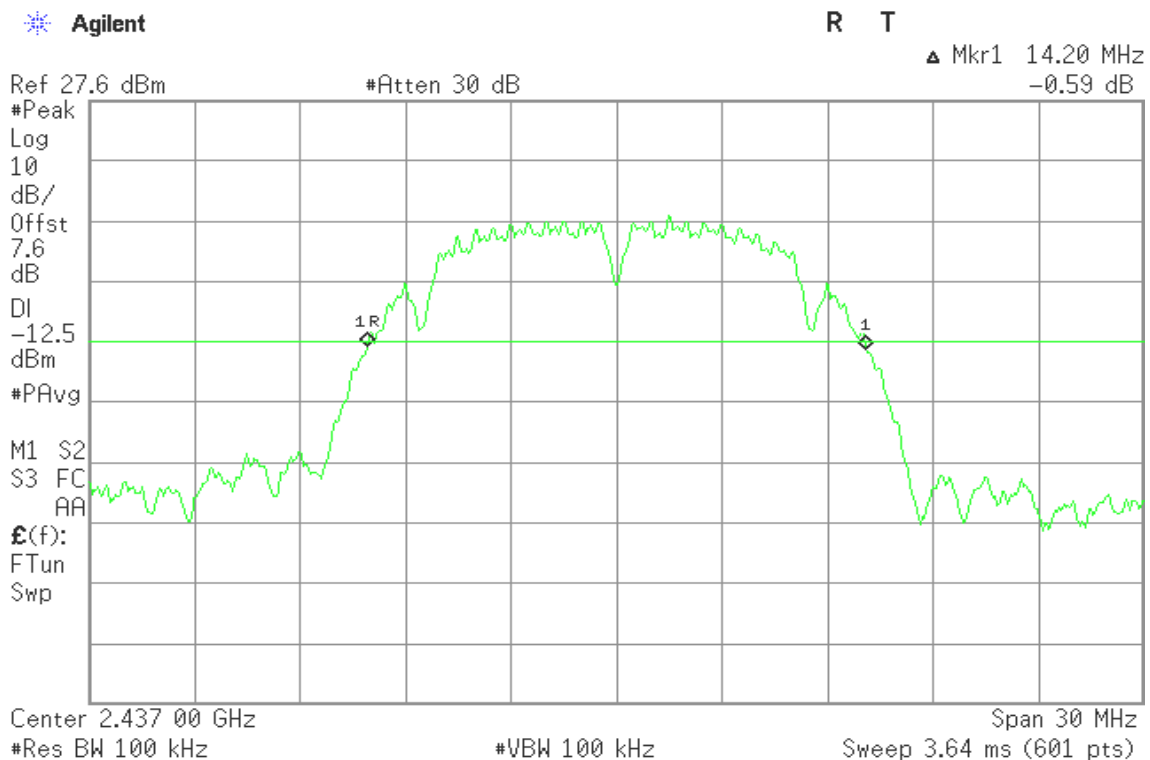





### 6dB Bandwidth (CH High)

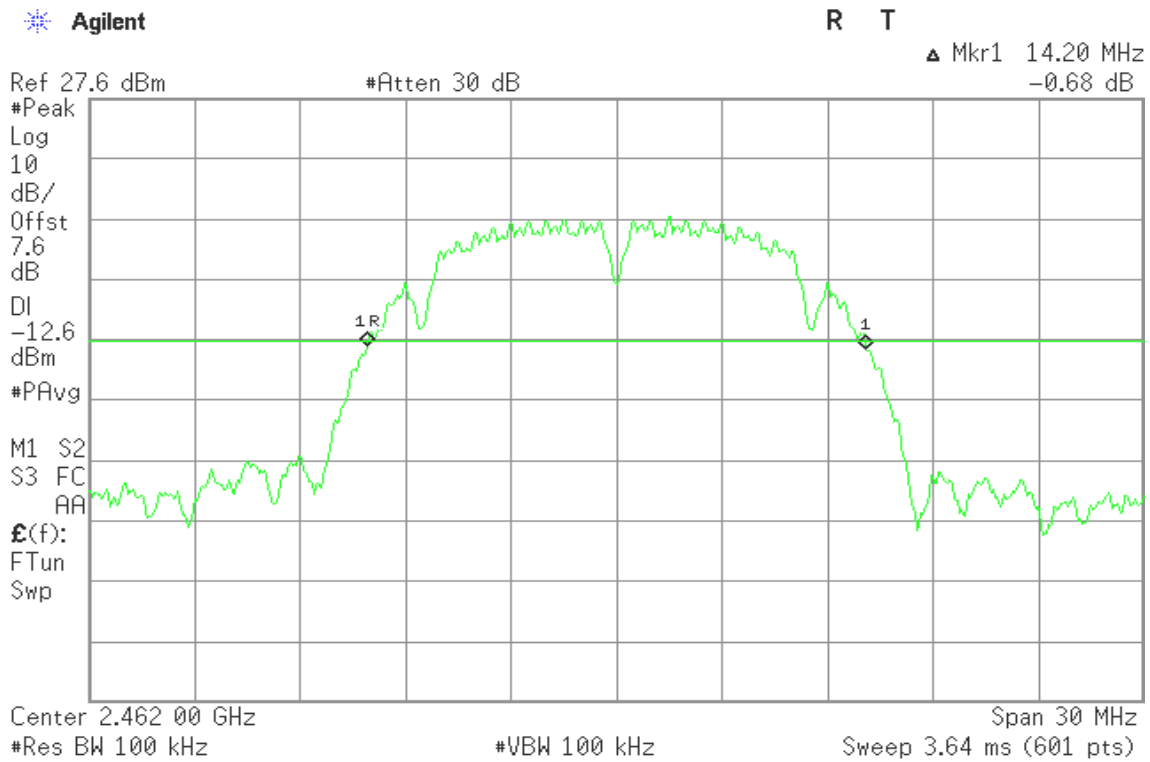

### IEEE 802.11g mode

### 6dB Bandwidth (CH Low)

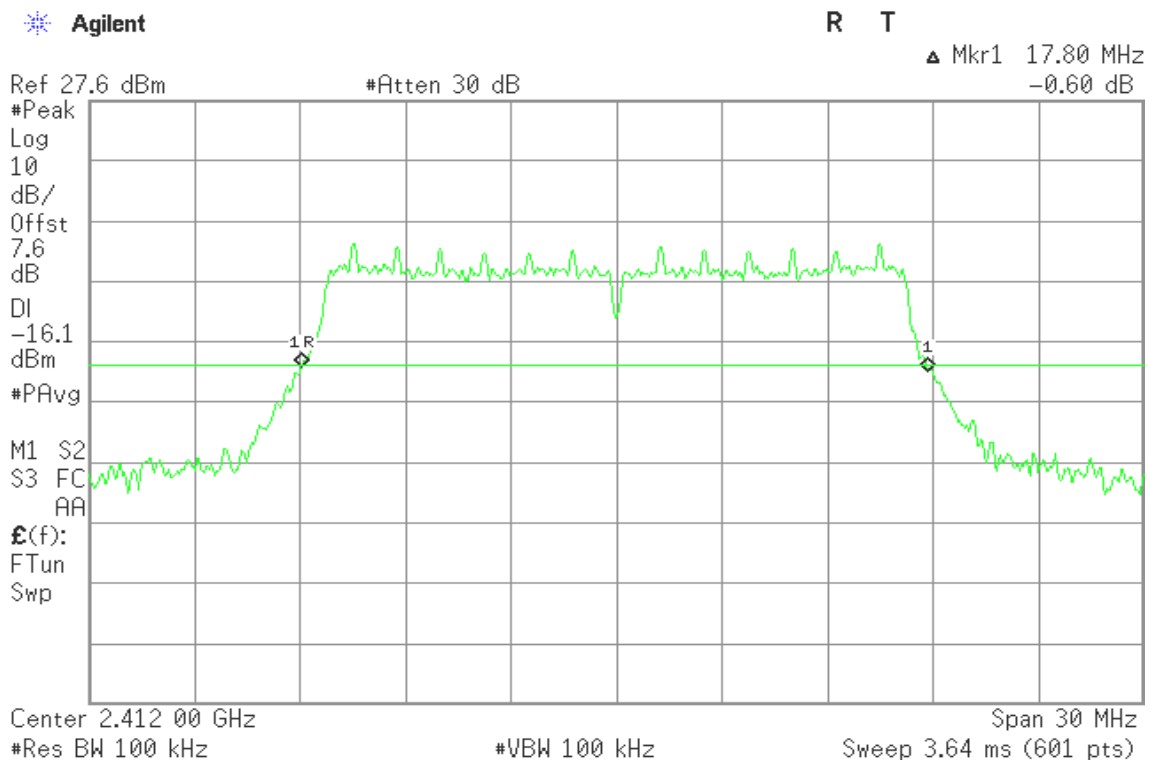



### 6dB Bandwidth (CH Mid)

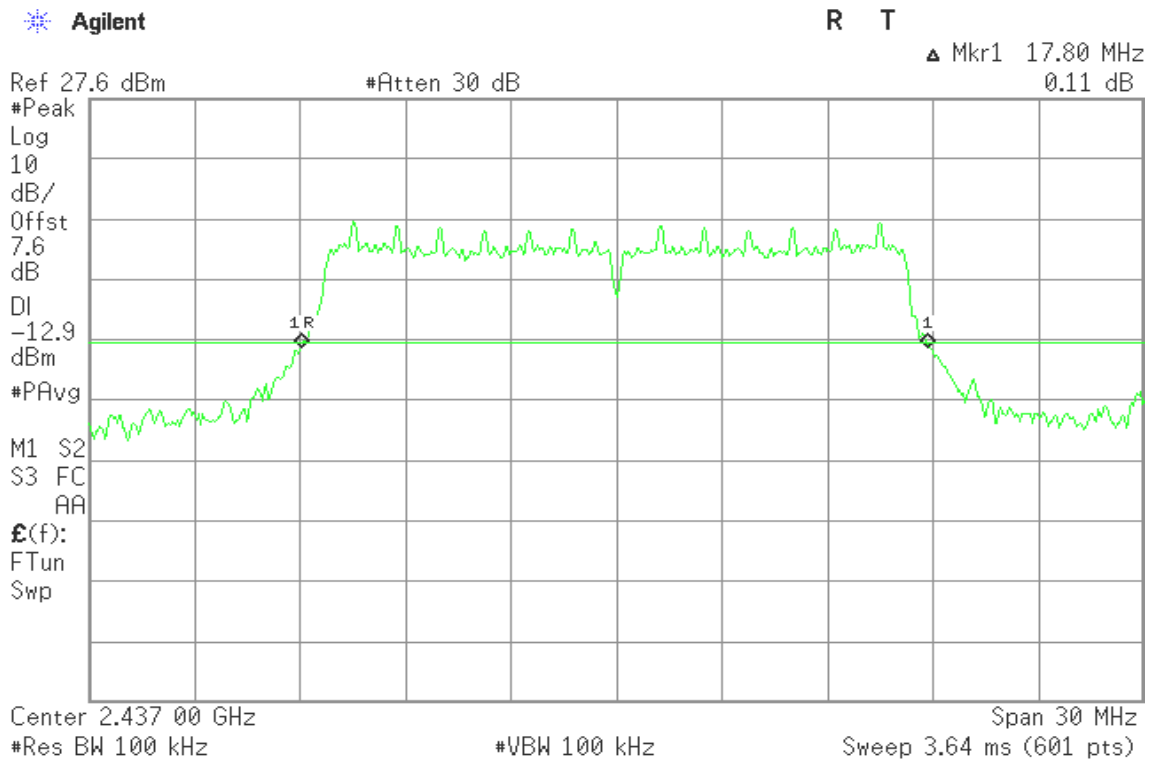

### 6dB Bandwidth (CH High)

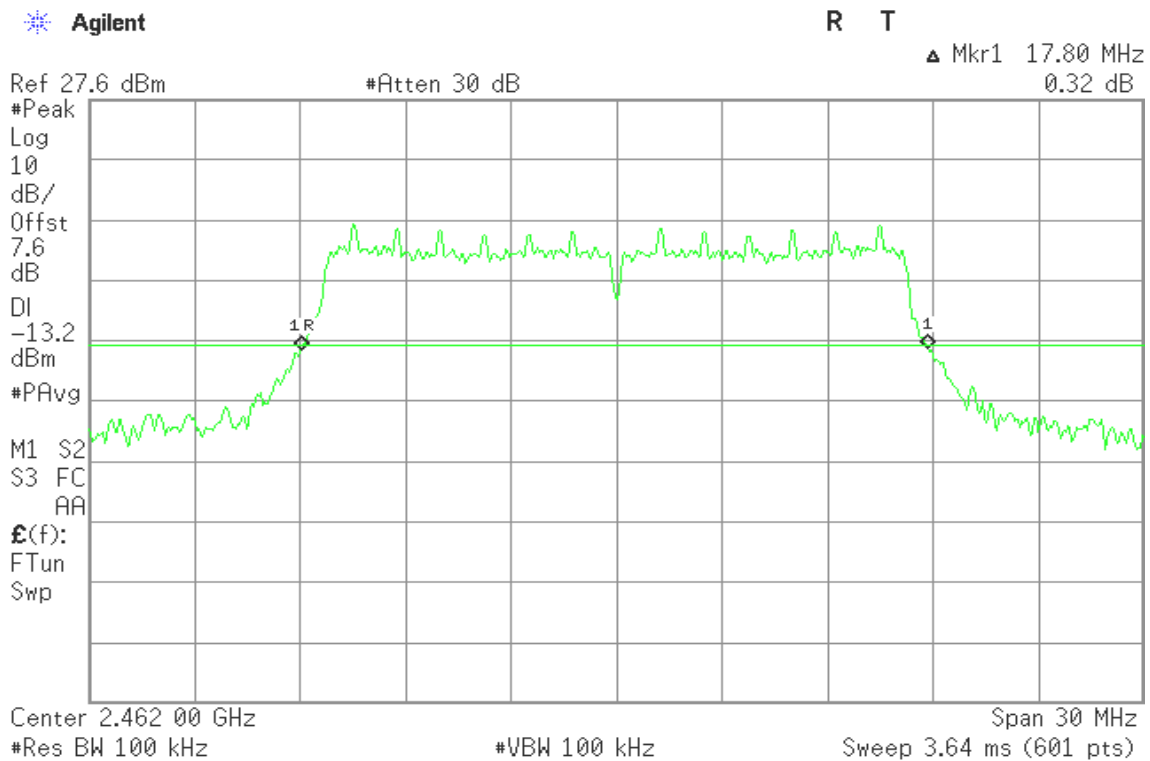



### IEEE 802.11n HT20 mode / Chain 0

#### 6dB Bandwidth (CH Low)

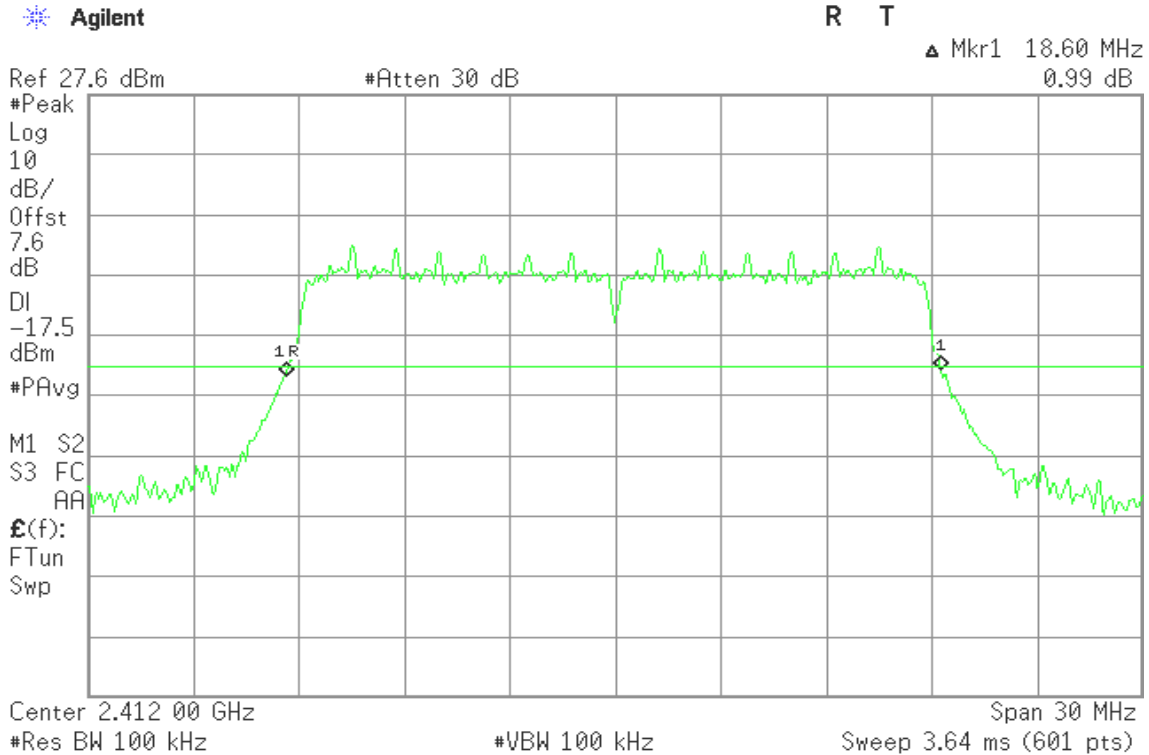

#### 6dB Bandwidth (CH Mid)

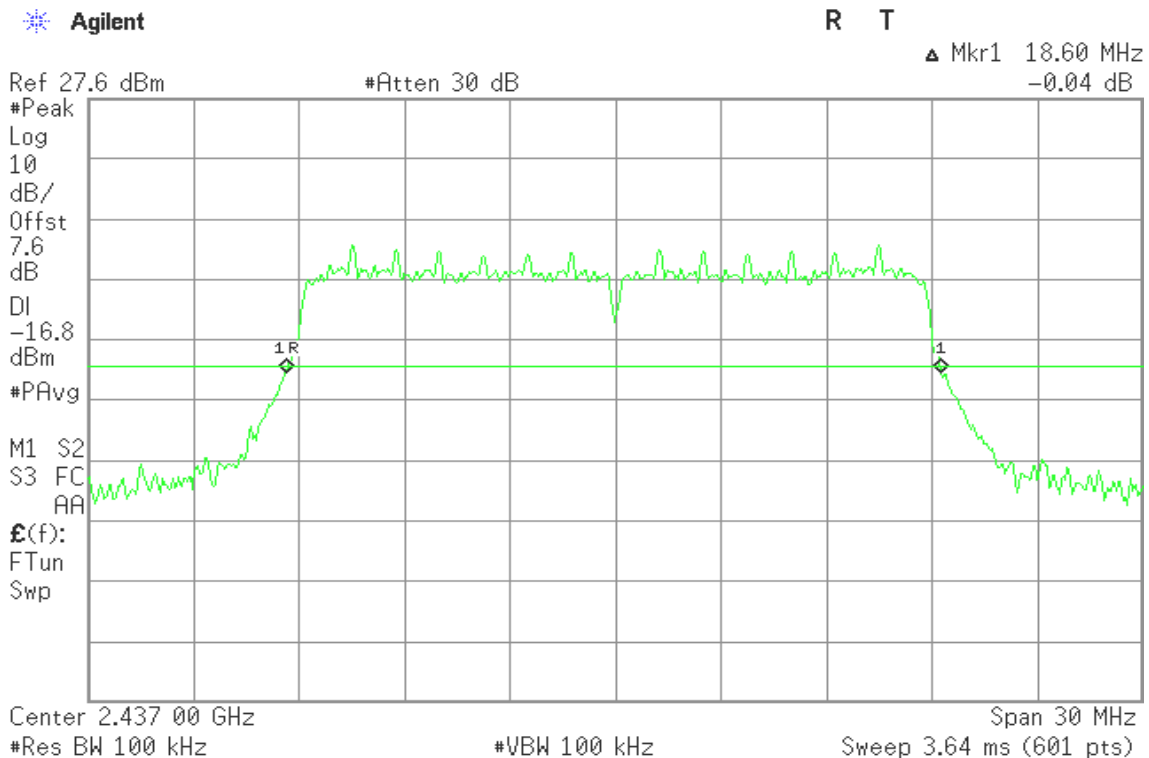



### 6dB Bandwidth (CH High)

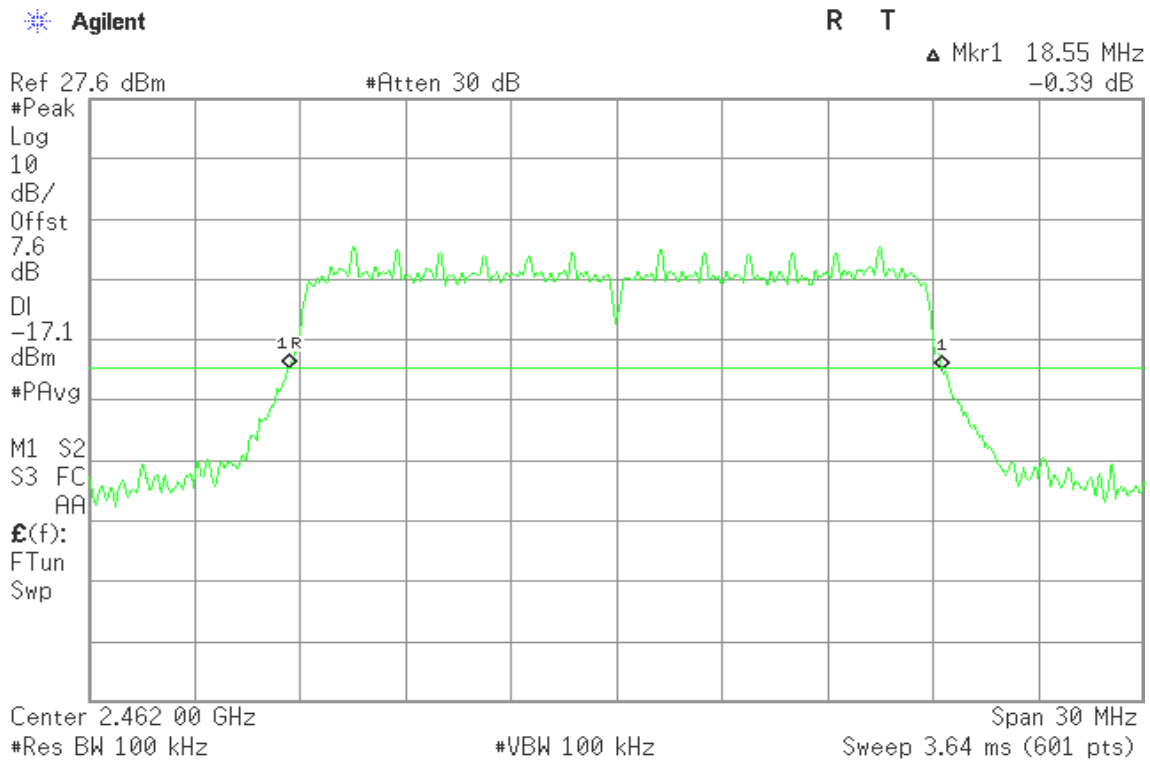

### IEEE 802.11n HT20 mode / Chain 1

### 6dB Bandwidth (CH Low)

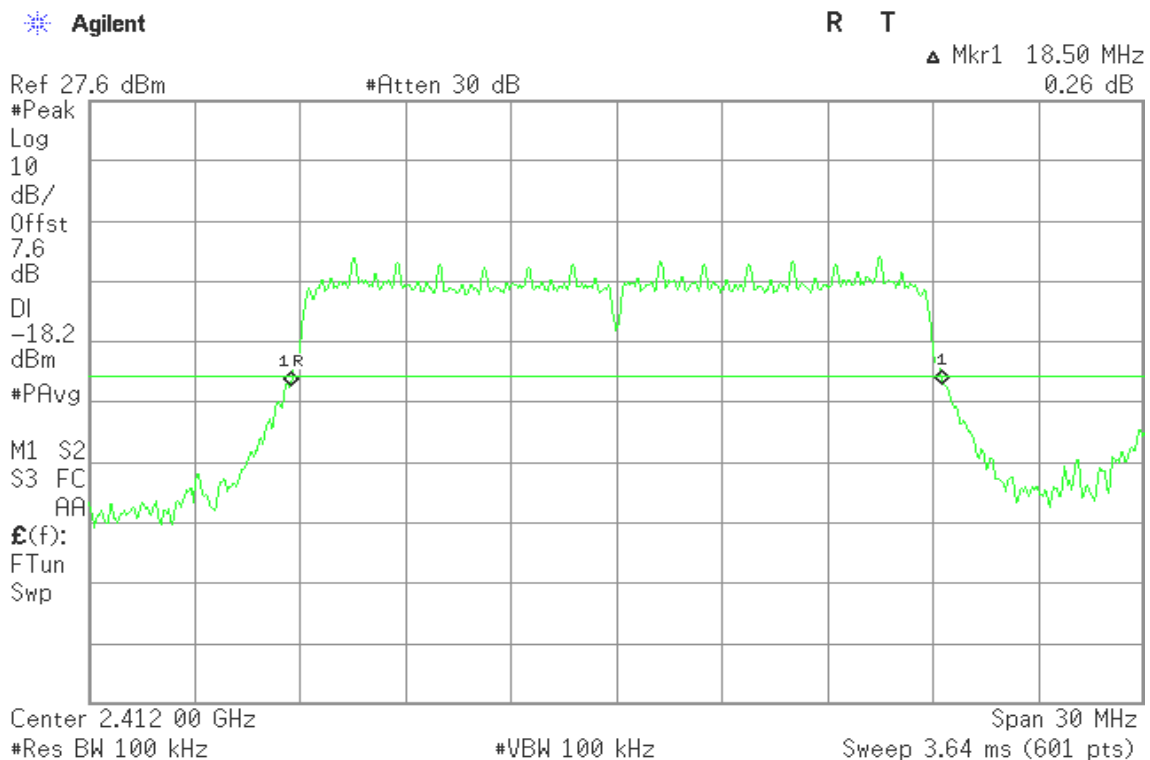



### 6dB Bandwidth (CH Mid)

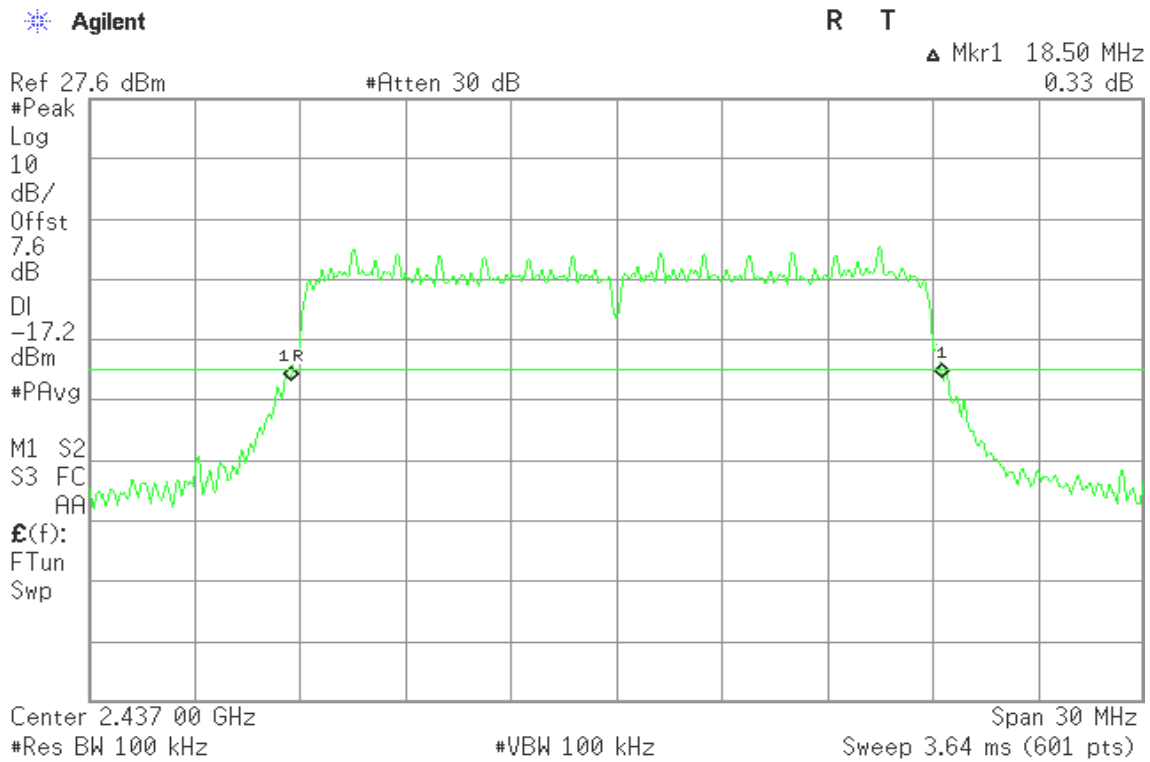

### 6dB Bandwidth (CH High)

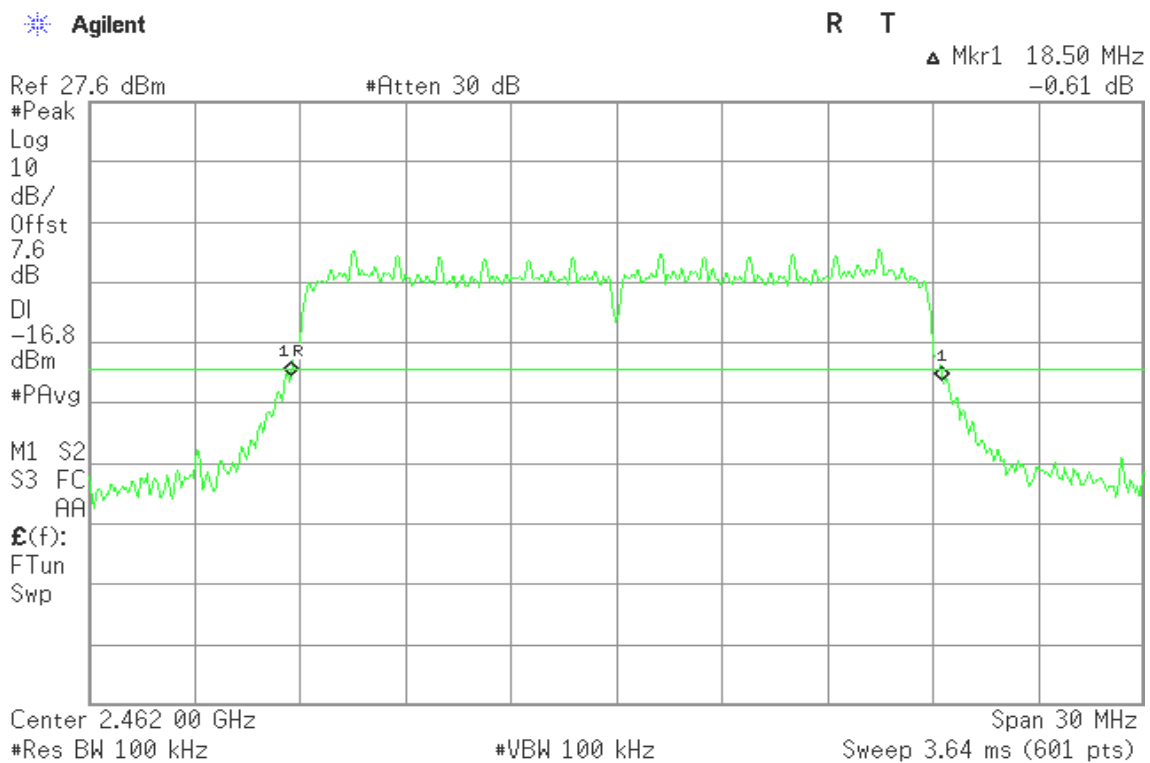



### IEEE 802.11n HT40 mode / Chain 0

#### 6dB Bandwidth (CH Low)

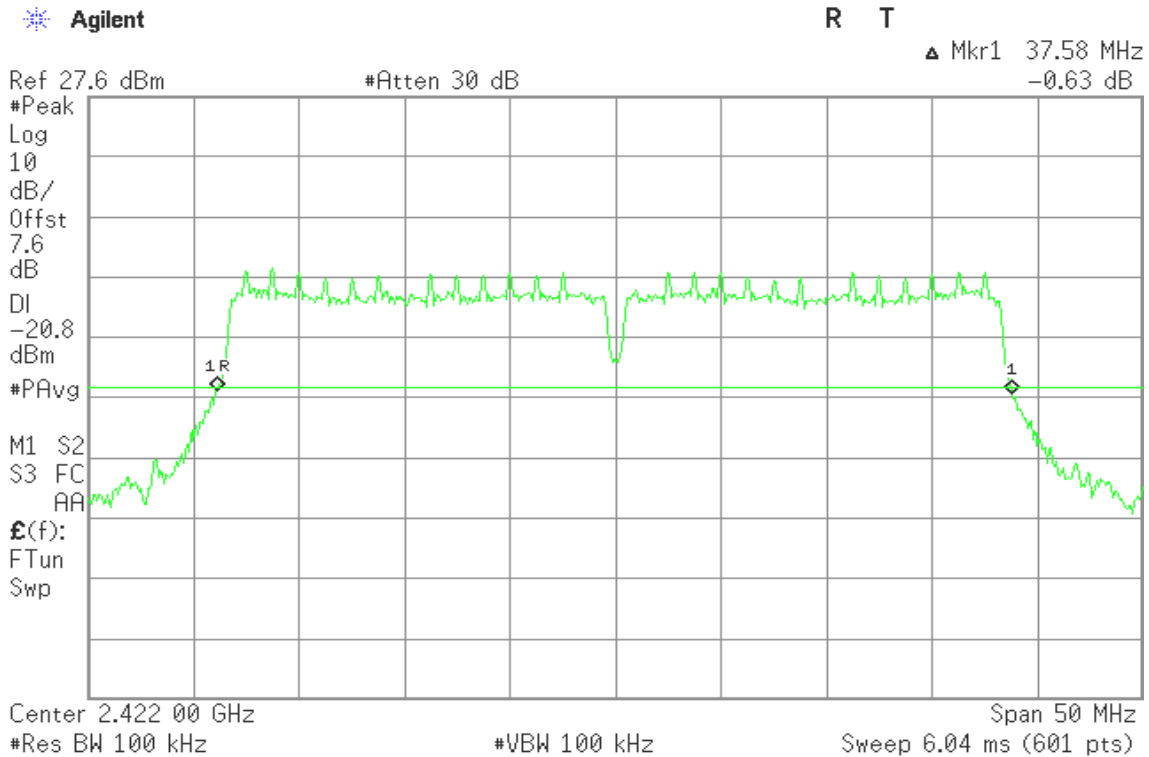

#### 6dB Bandwidth (CH Mid)

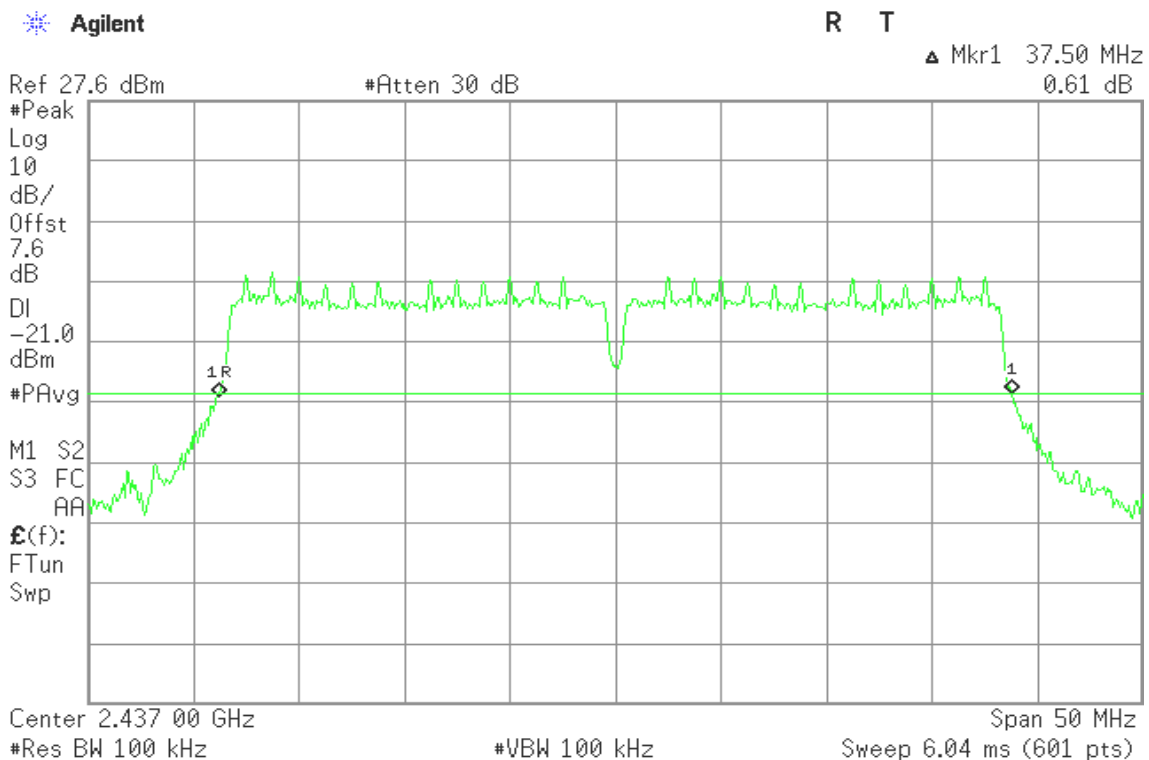



### 6dB Bandwidth (CH High)

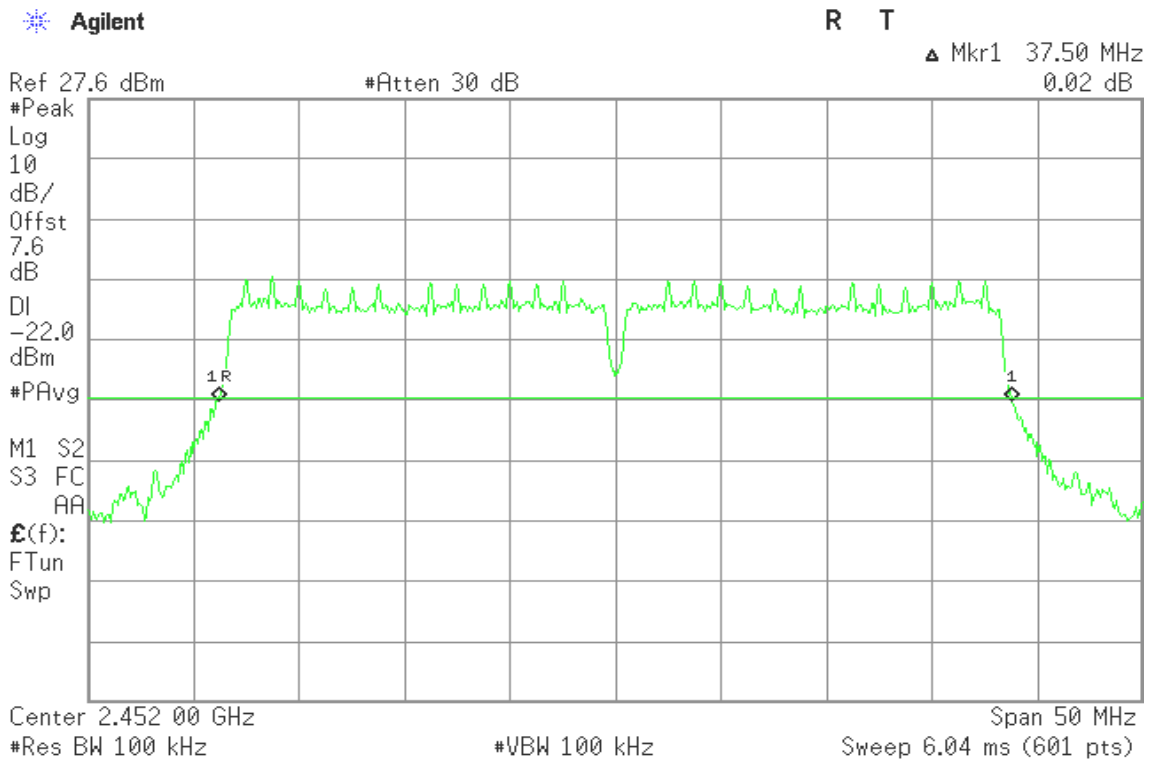

### IEEE 802.11n HT40 mode / Chain 1

### 6dB Bandwidth (CH Low)

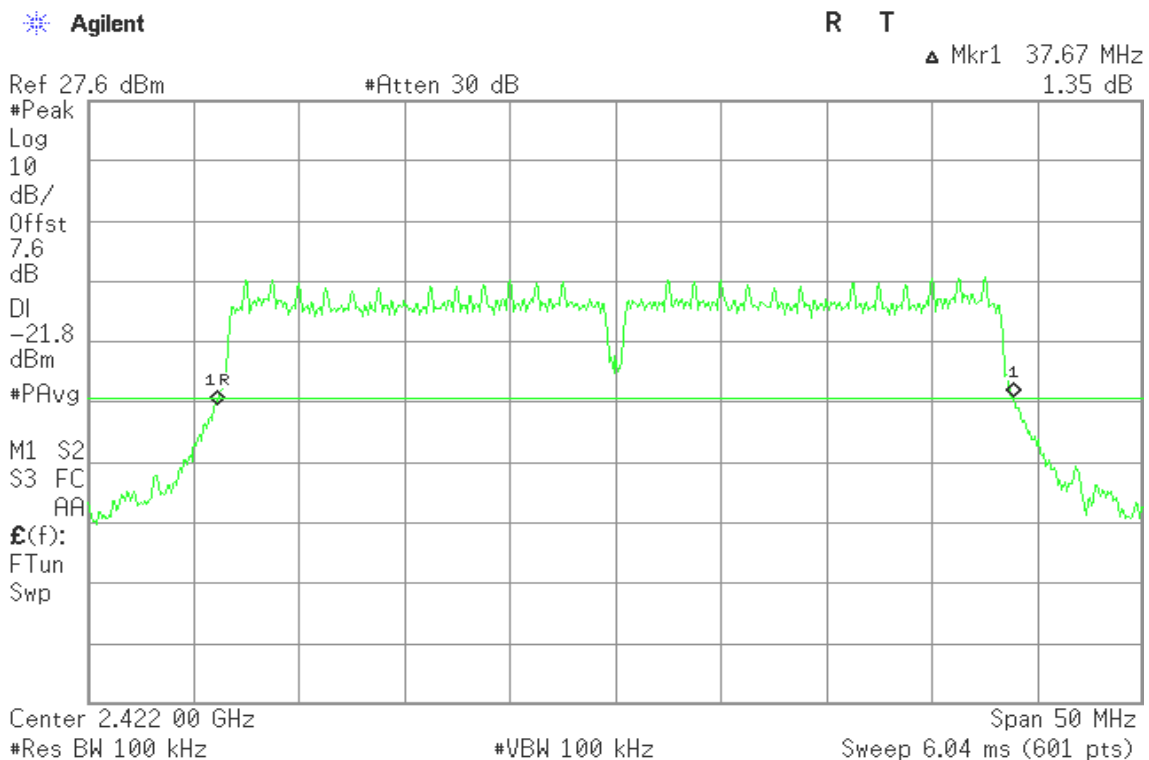



### 6dB Bandwidth (CH Mid)

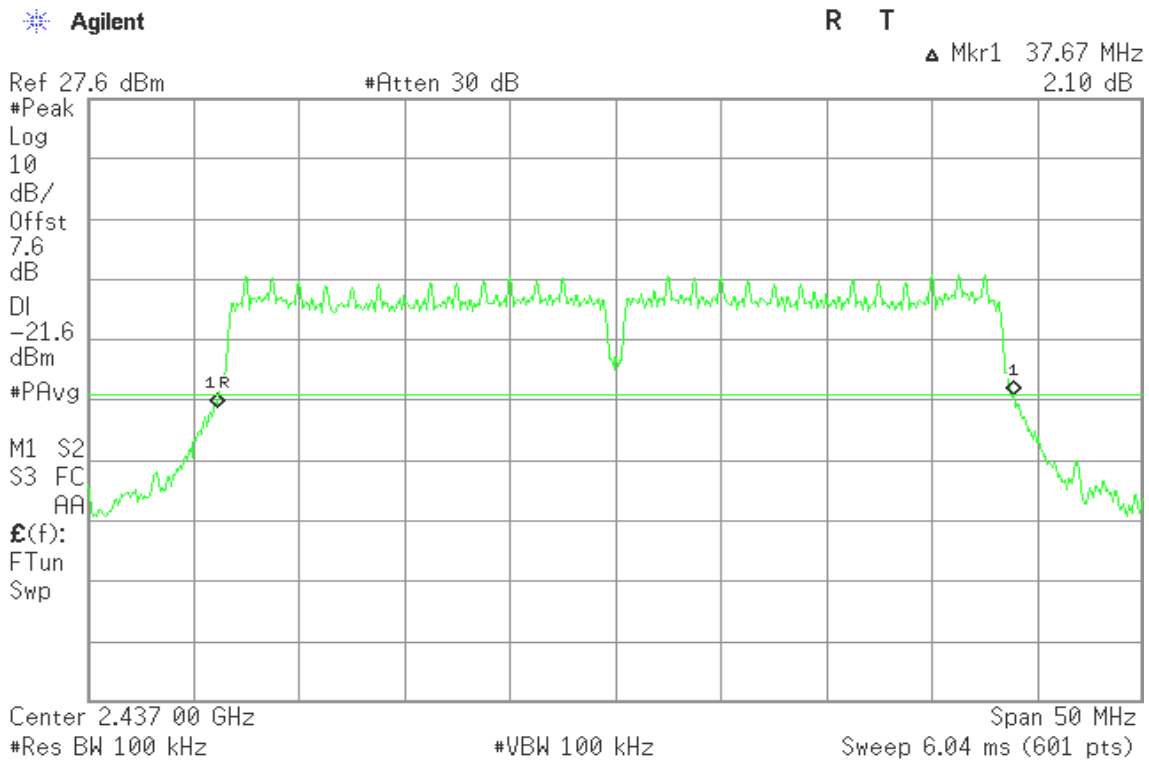

### 6dB Bandwidth (CH High)

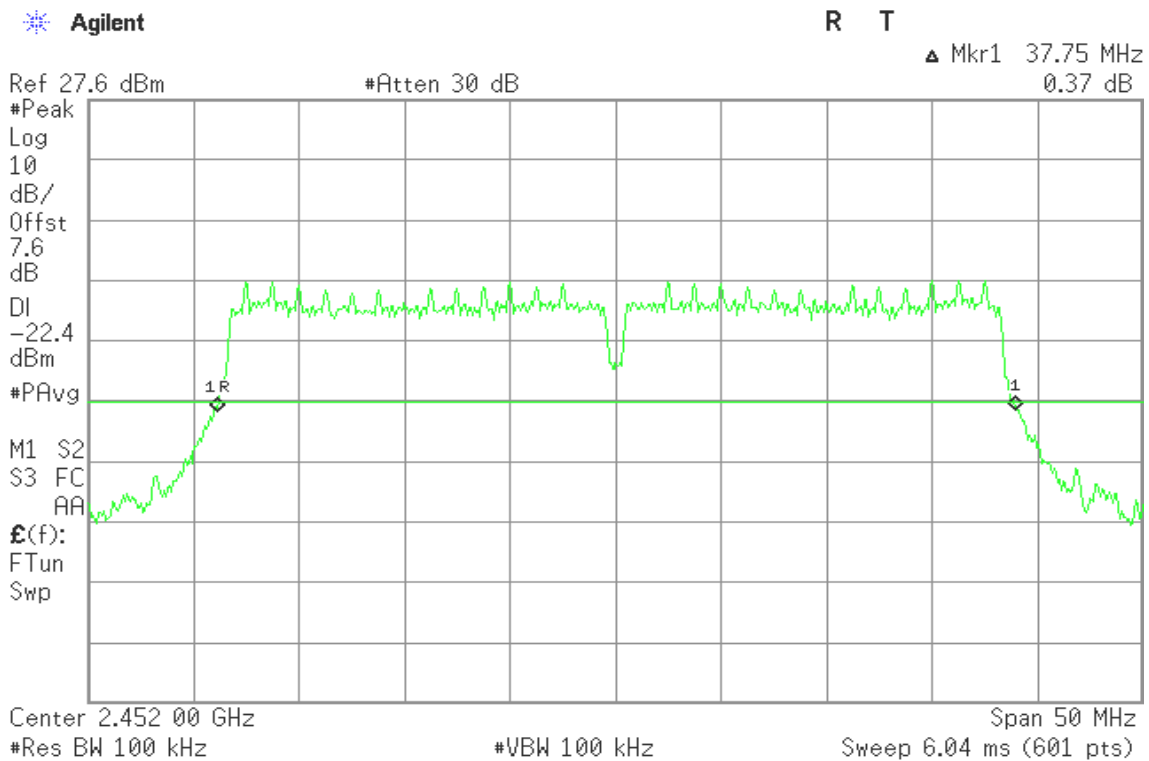





## **7.2 PEAK POWER**

### **LIMIT**

The maximum peak output power of the intentional radiator shall not exceed the following:

1. According to §15.247(b)(3), for systems using digital modulation in the bands of 902-928 MHz, 2400-2483.5 MHz, and 5725-5850 MHz: 1 Watt.
2. According to §15.247(b)(4), the conducted output power limit specified in paragraph (b) of this section is based on the use of antennas with directional gains that do not exceed 6 dBi. Except as shown in paragraph (c) of this section, if transmitting antennas of directional gain greater than 6 dBi are used, the conducted output power from the intentional radiator shall be reduced below the stated values in paragraphs (b)(1), (b)(2), and (b)(3) of this section, as appropriate, by the amount in dB that the directional gain of the antenna exceeds 6 dBi.

### **TEST CONFIGURATION**

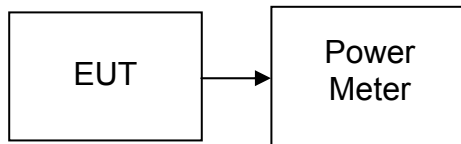

### **TEST PROCEDURE**

**Per KDB 558074 V02**

The transmitter output is connected to the Power Meter. The Power Meter is set to the peak power detection.

### **TEST RESULTS**

*No non-compliance noted*



### TEST DATA

#### Test mode: IEEE 802.11b mode

Channel	Frequency (MHz)	Output Power (dBm)	Output Power (W)	Limit (W)	Result
Low	2412	19.89	0.0975	1	PASS
Mid	2437	20.71	0.1178		PASS
High	2462	20.66	0.1164		PASS

#### Test mode: IEEE 802.11g mode

Channel	Frequency (MHz)	Output Power (dBm)	Output Power (W)	Limit (W)	Result
Low	2412	22.62	0.1828	1	PASS
Mid	2437	23.28	0.2128		PASS
High	2462	22.95	0.1972		PASS

#### Test mode: IEEE 802.11n HT20 mode

Channel	Frequency (MHz)	Output Power (dBm)			Output Power (W)			Limit (W)	Result
		Chain 0	Chain 1	Total	Chain 0	Chain 1	Total		
Low	2412	20.51	20.4	23.47	0.1125	0.1096	0.2221	1	PASS
Mid	2437	21.29	21.72	24.52	0.1346	0.1486	0.2832		PASS
High	2462	21.23	22.11	24.70	0.1327	0.1626	0.2953		PASS

#### Test mode: IEEE 802.11n HT40 mode

Channel	Frequency (MHz)	Output Power (dBm)			Output Power (W)			Limit (W)	Result
		Chain 0	Chain 1	Total	Chain 0	Chain 1	Total		
Low	2422	20.77	20.9	23.85	0.1194	0.1230	0.2424	1	PASS
Mid	2437	20.72	21.18	23.97	0.1180	0.1312	0.2493		PASS
High	2452	19.74	20.51	23.15	0.0942	0.1125	0.2066		PASS

**Remark:**

1. Total Output Power (w) = Chain 0 (10^(Output Power /10)/1000) + Chain 1 (10^(Output Power /10)/1000))
2. The maximum antenna gain is 7.32dBi.



## **7.3 AVERAGE POWER**

### **LIMIT**

None; for reporting purposes only.

### **TEST CONFIGURATION**

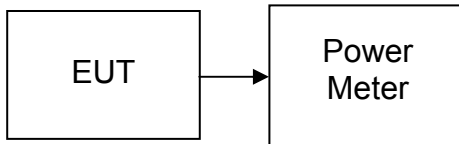

### **TEST PROCEDURE**

**Per KDB 558074 V02**

The transmitter output is connected to the Power Meter. The Power Meter is set to the peak power detection.

### **TEST RESULTS**

*No non-compliance noted*



### TEST DATA

#### Test mode: IEEE 802.11b mode

Channel	Frequency (MHz)	Output Power (dBm)	Output Power (W)
Low	2412	16.40	0.0437
Mid	2437	17.77	0.0598
High	2462	17.62	0.0578

#### Test mode: IEEE 802.11g mode

Channel	Frequency (MHz)	Output Power (dBm)	Output Power (W)
Low	2412	13.22	0.0210
Mid	2437	13.15	0.0207
High	2462	13.22	0.0210

#### Test mode: IEEE 802.11n HT20 mode

Channel	Frequency (MHz)	Output Power (dBm)			Output Power (W)		
		Chain 0	Chain 1	Total	Chain 0	Chain 1	Total
Low	2412	12.73	12.36	15.56	0.0187	0.0172	0.0360
Mid	2437	13.22	13.57	16.41	0.0210	0.0228	0.0437
High	2462	13.18	14.02	16.63	0.0208	0.0252	0.0460

#### Test mode: IEEE 802.11n HT40 mode

Channel	Frequency (MHz)	Output Power (dBm)			Output Power (W)		
		Chain 0	Chain 1	Total	Chain 0	Chain 1	Total
Low	2422	12.48	12.41	15.46	0.0177	0.0174	0.0351
Mid	2437	12.11	12.48	15.31	0.0163	0.0177	0.0340
High	2452	11.53	12.15	14.86	0.0142	0.0164	0.0306



## 7.4 BAND EDGES MEASUREMENT

### LIMIT

According to §15.247(d), in any 100 kHz bandwidth outside the frequency bands in which the spread spectrum intentional radiator is operating, the radio frequency power that is produced by the intentional radiator shall be at least 20 dB below that in the 100 kHz bandwidth within the band that contains the highest level of the desired power, based on either an RF conducted or a radiated measurement, provided the transmitter demonstrates compliance with the peak conducted power limits. In addition, radiated emissions which fall in the restricted bands, as defined in §15.205(a), must also comply with the radiated emission limits specified in 15.209(a) (see Section 15.205(c)).

### TEST CONFIGURATION

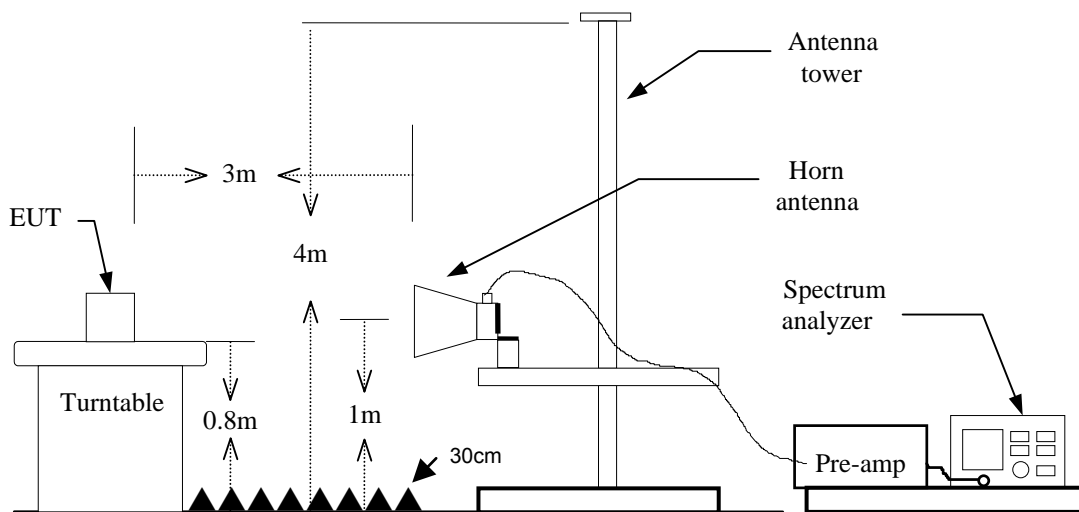

### TEST PROCEDURE

1. The EUT is placed on a turntable, which is 0.8m above the ground plane.
2. The turntable shall be rotated for 360 degrees to determine the position of maximum emission level.
3. EUT is set 3m away from the receiving antenna, which is varied from 1m to 4m to find out the highest emission.
4. Set the spectrum analyzer in the following setting in order to capture the lower and upper band-edges of the emission:
  - (a) PEAK: RBW=VBW=1MHz / Sweep=100ms
  - (b) AVERAGE: RBW=1MHz / VBW=10Hz / Sweep=AUTO
5. Repeat the procedures until all the PEAK and AVERAGE versus POLARIZATION are measured.

### TEST RESULTS

Refer to attach spectrum analyzer data chart.



### Test Plot

### Band Edges (IEEE 802.11b mode / CH Low)

Detector mode: Peak

Polarity: Vertical

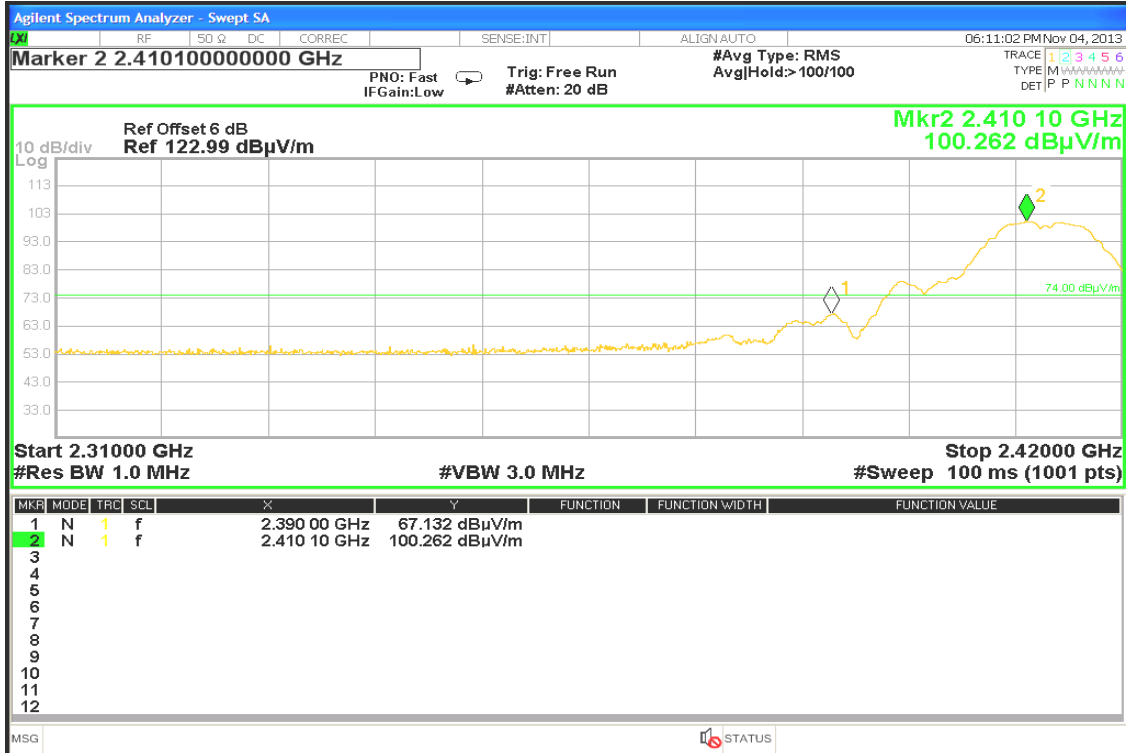

Detector mode: Average

Polarity: Vertical

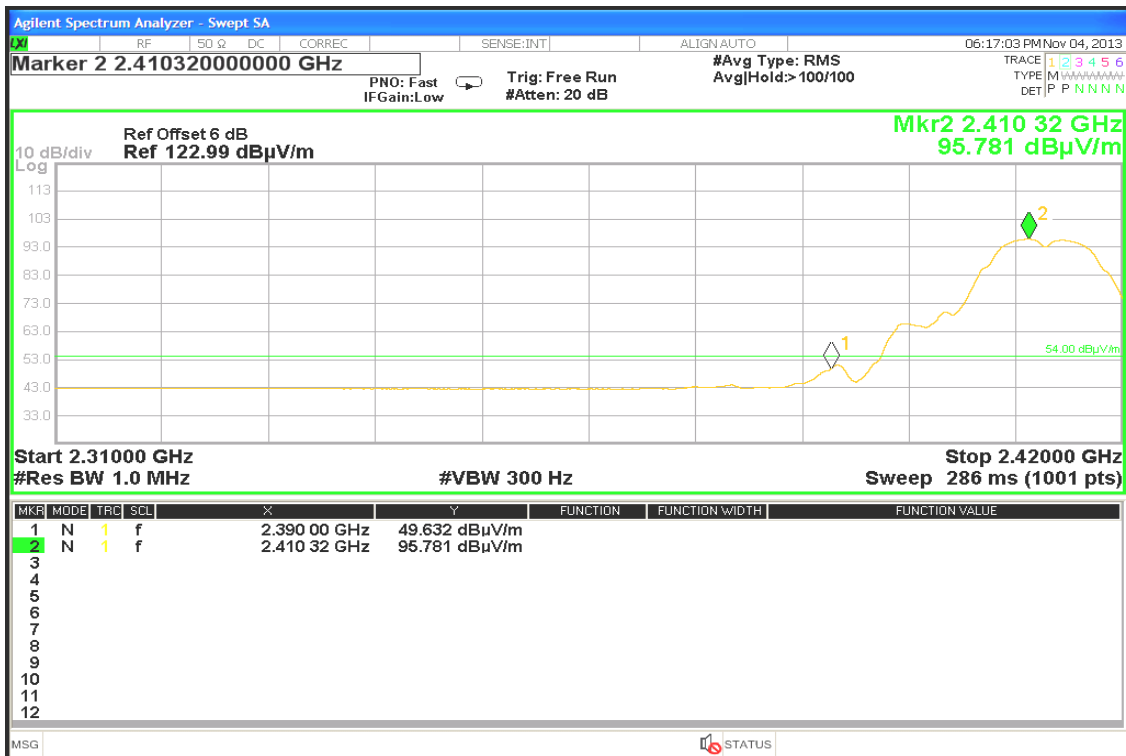



Detector mode: Peak

Polarity: Horizontal

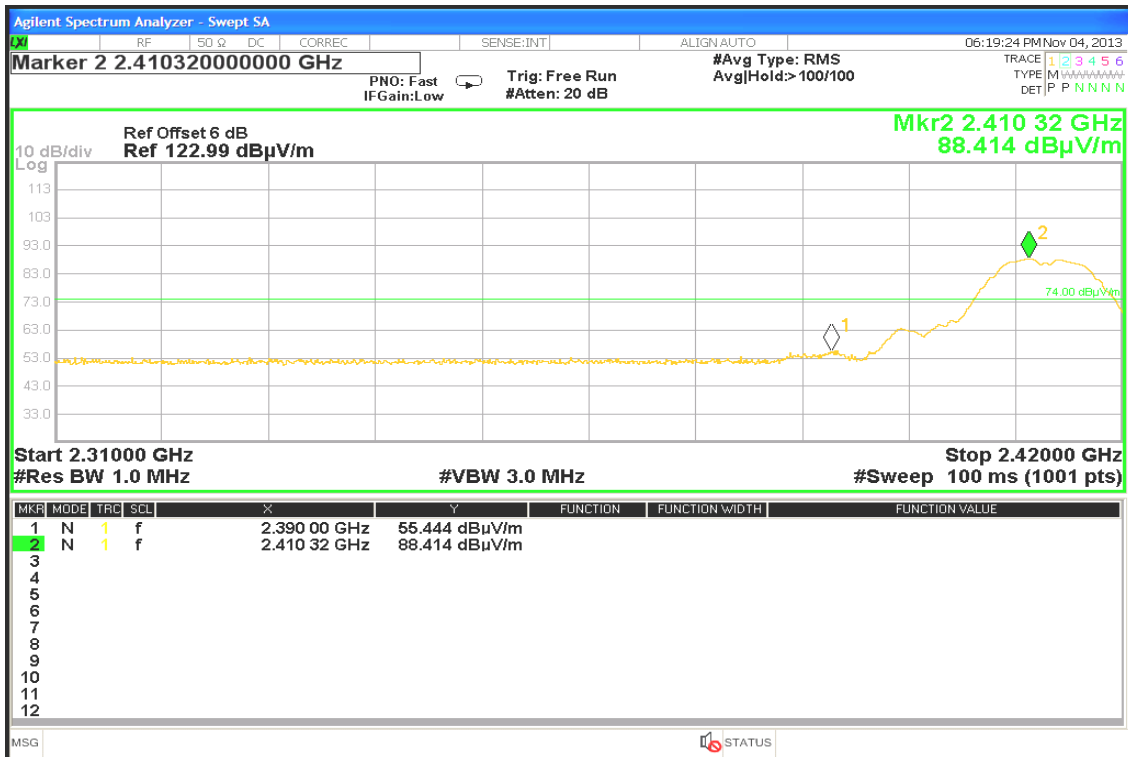

Detector mode: Average

Polarity: Horizontal

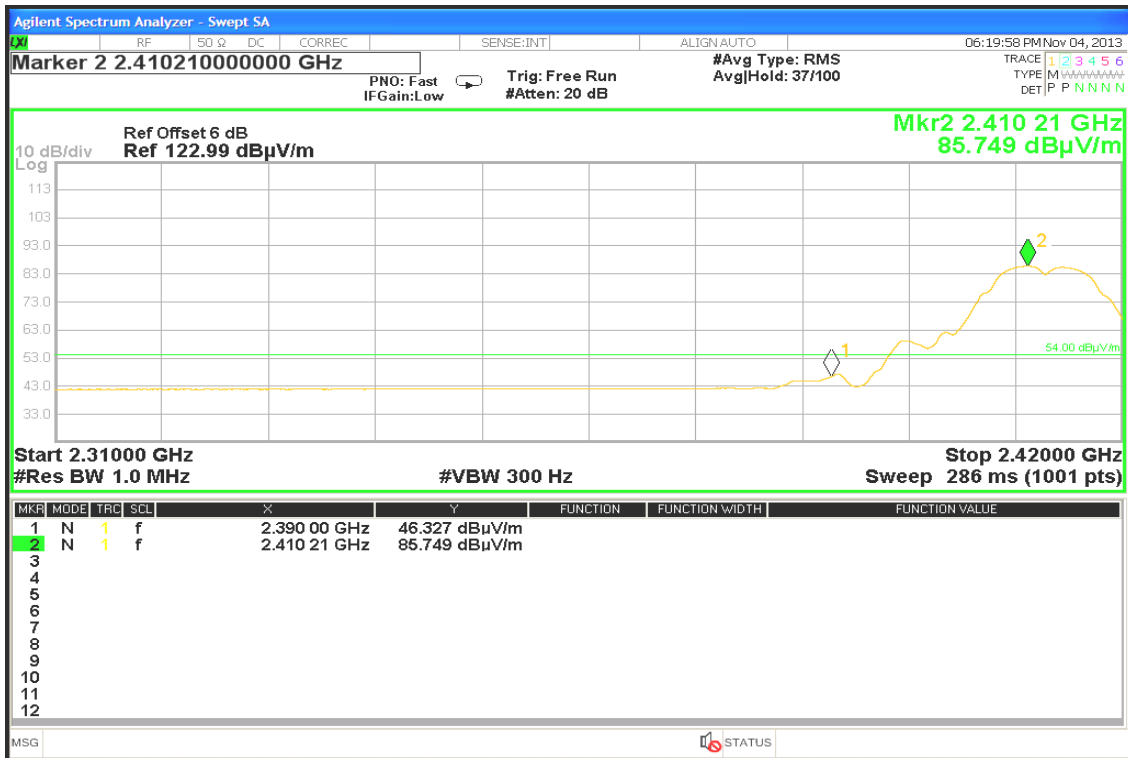



### Band Edges (IEEE 802.11b mode / CH High)

Detector mode: Peak

Polarity: Vertical

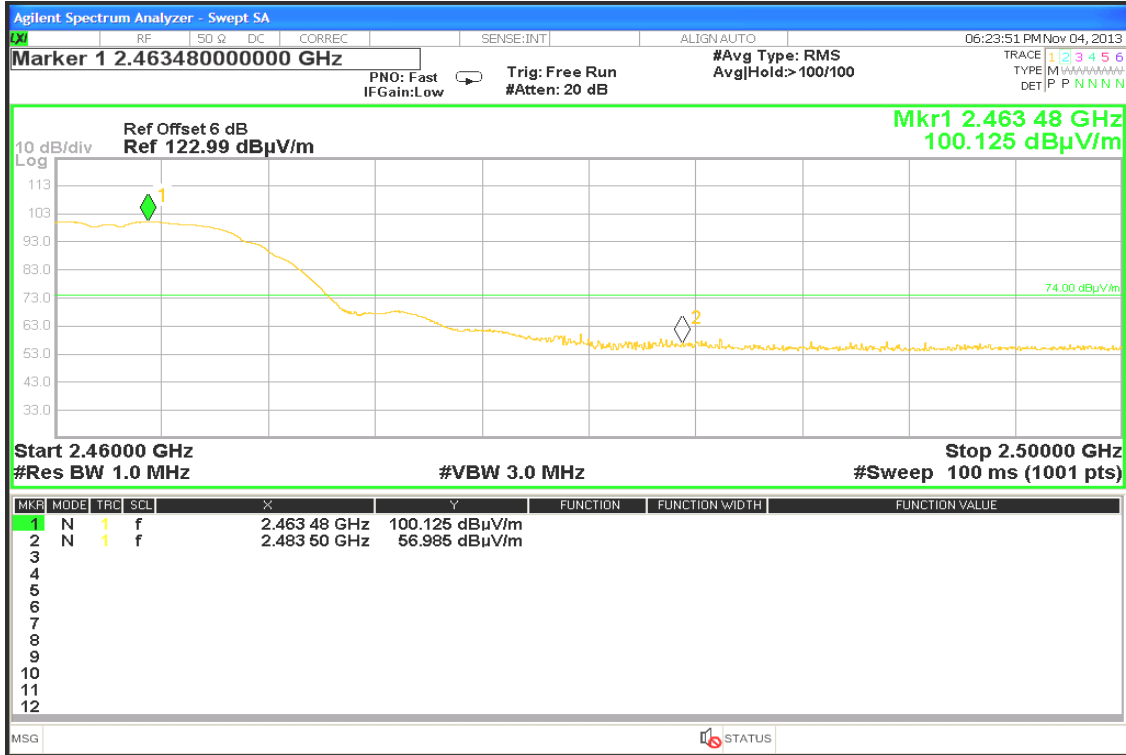

Detector mode: Average

Polarity: Vertical

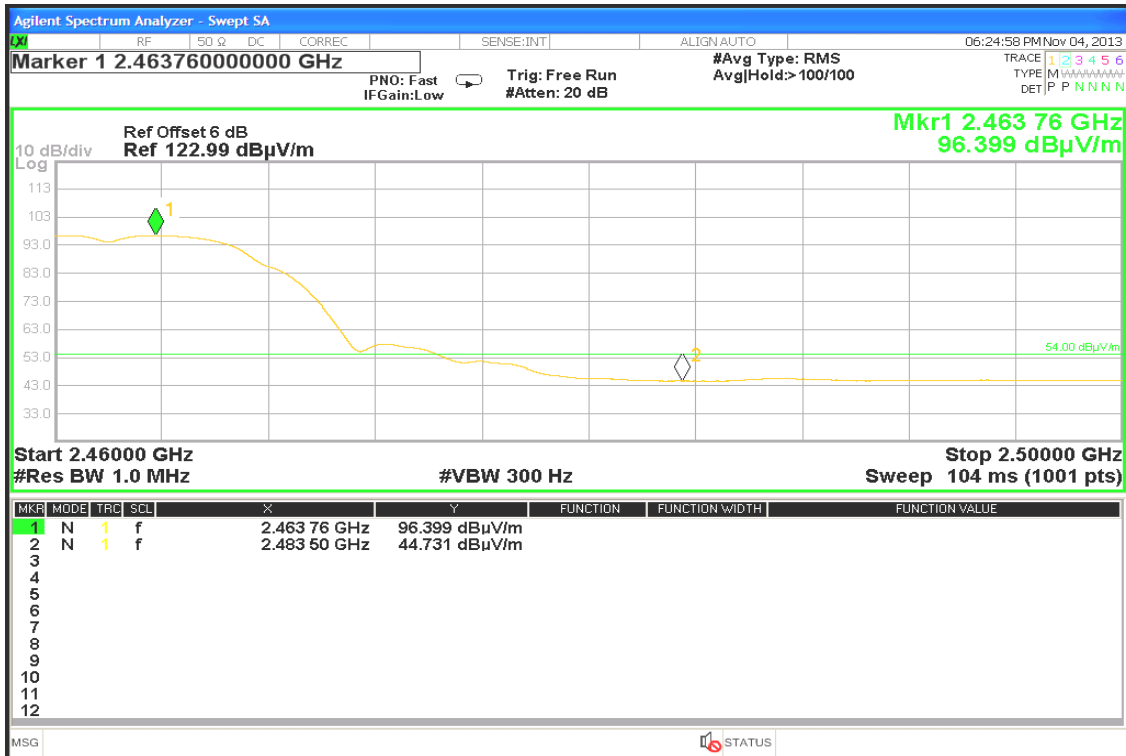





Detector mode: Peak

Polarity: Horizontal

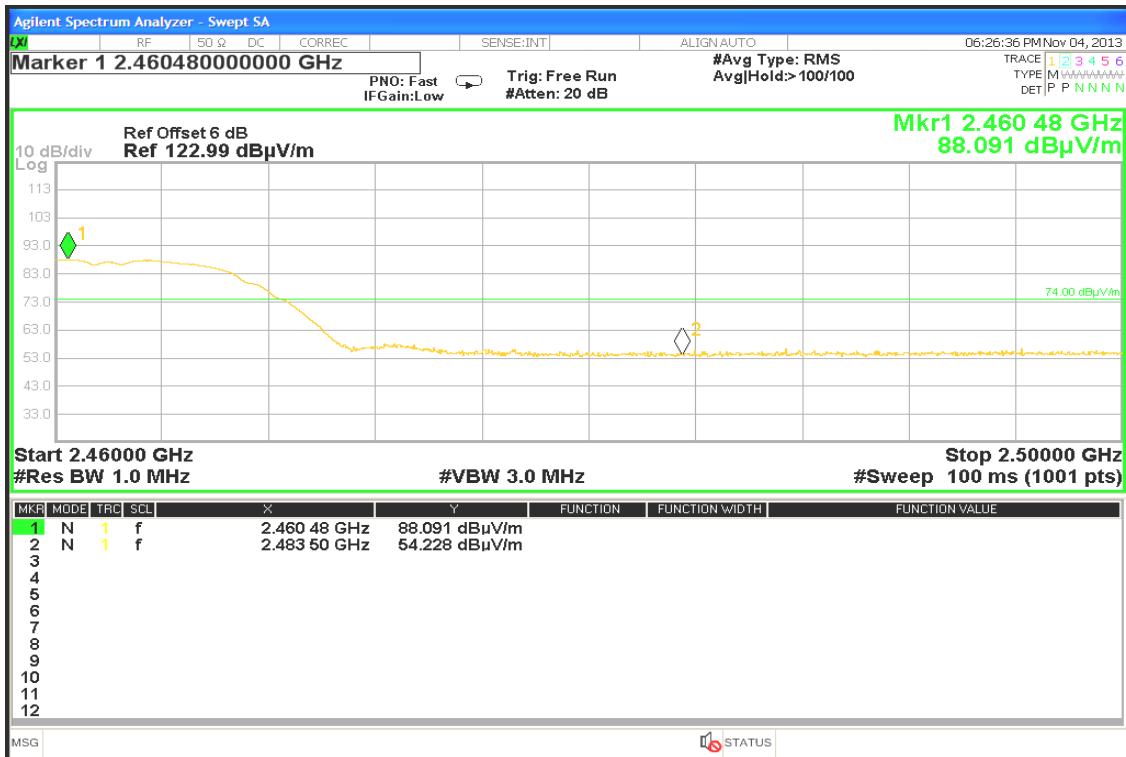

Detector mode: Average

Polarity: Horizontal

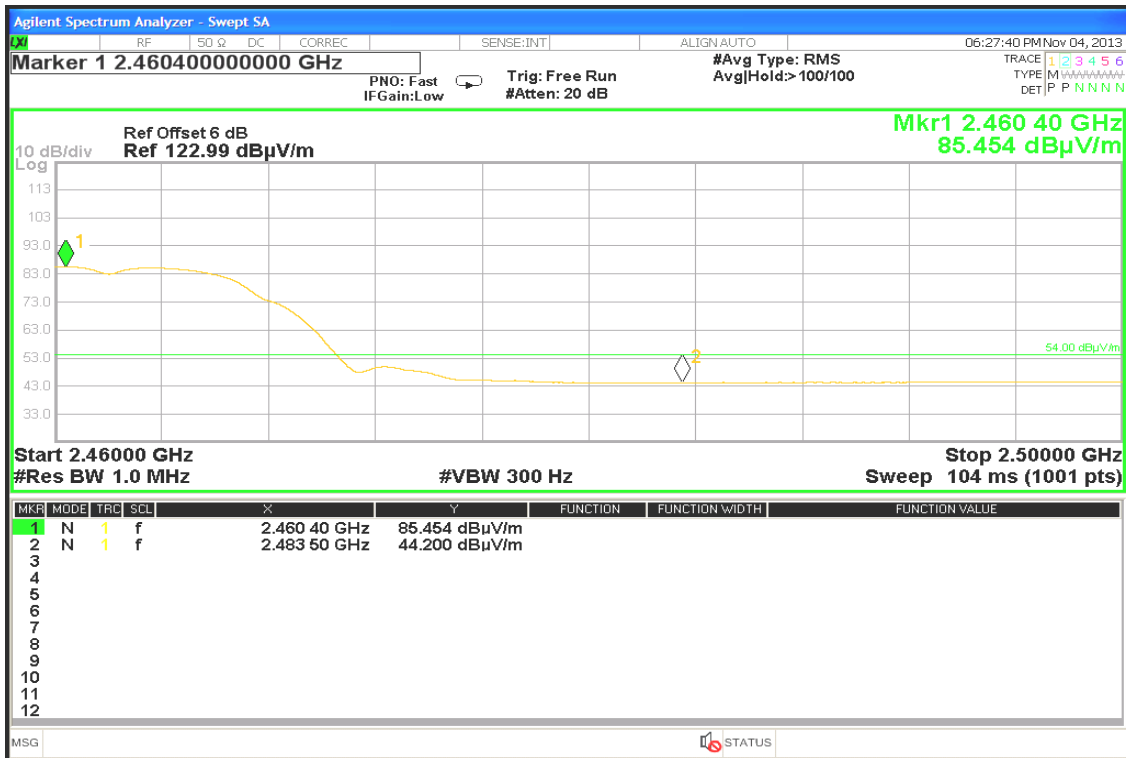



### Band Edges (IEEE 802.11g mode / CH Low)

Detector mode: Peak

Polarity: Vertical

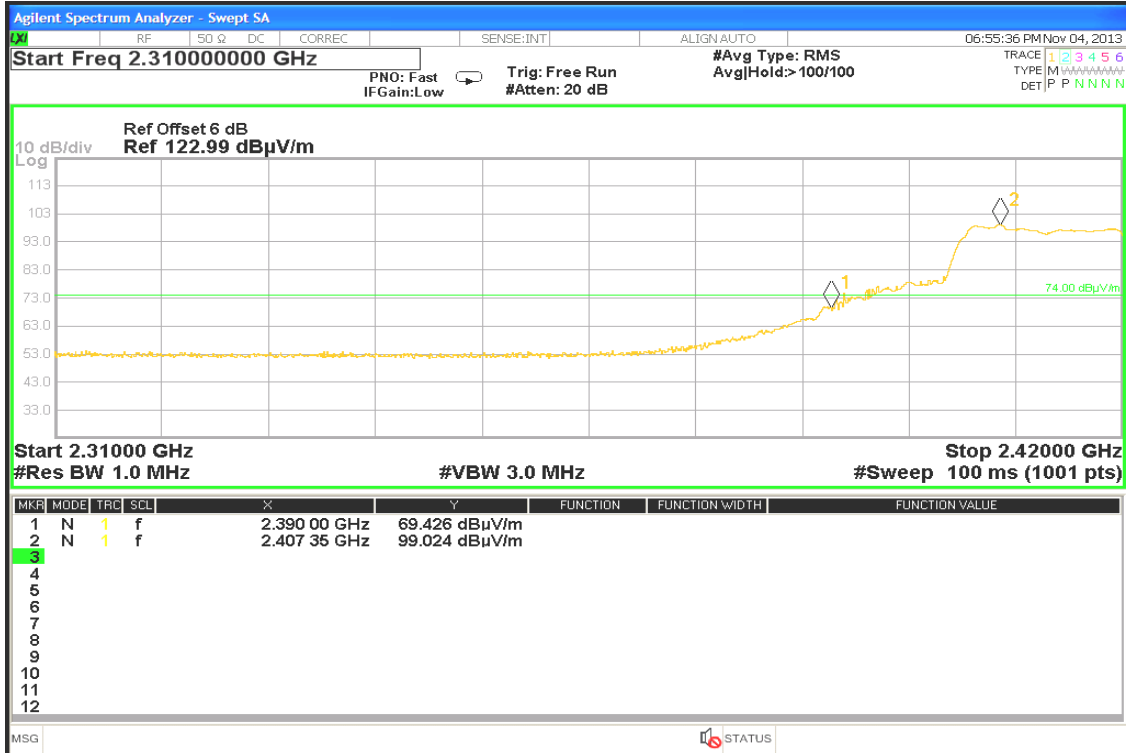

Detector mode: Average

Polarity: Vertical





Detector mode: Peak

Polarity: Horizontal

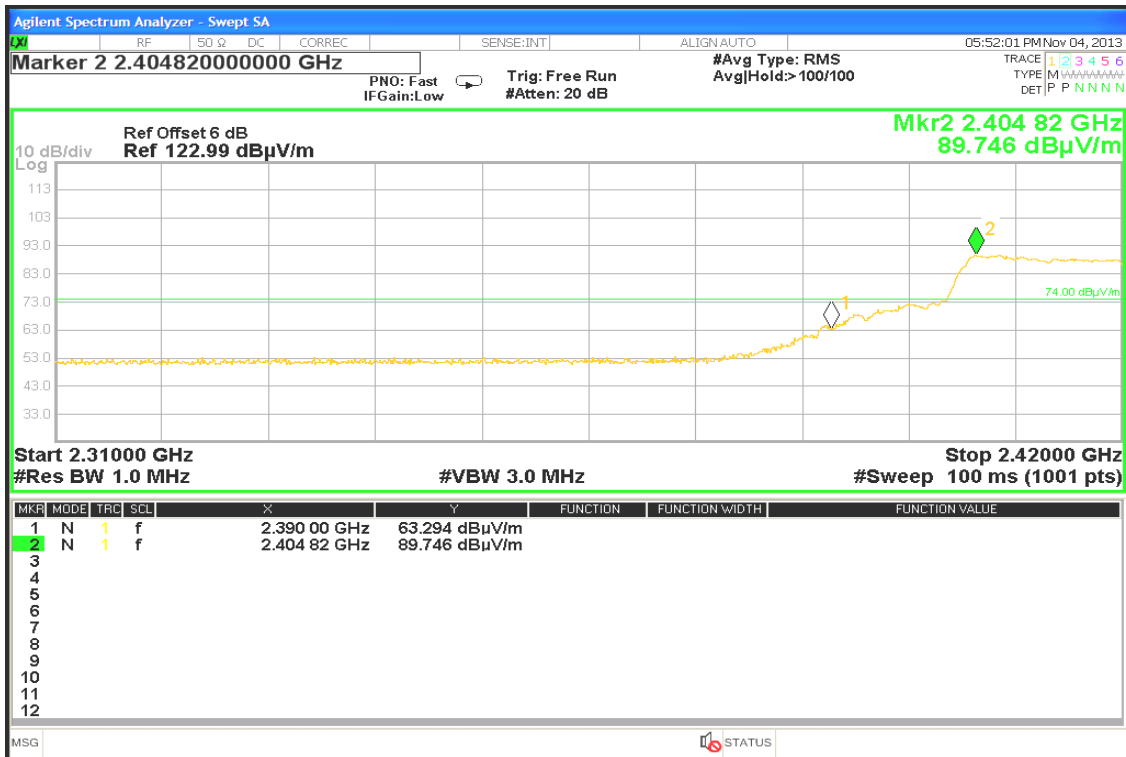

Detector mode: Average

Polarity: Horizontal





### Band Edges (IEEE 802.11g mode / CH High)

Detector mode: Peak

Polarity: Vertical

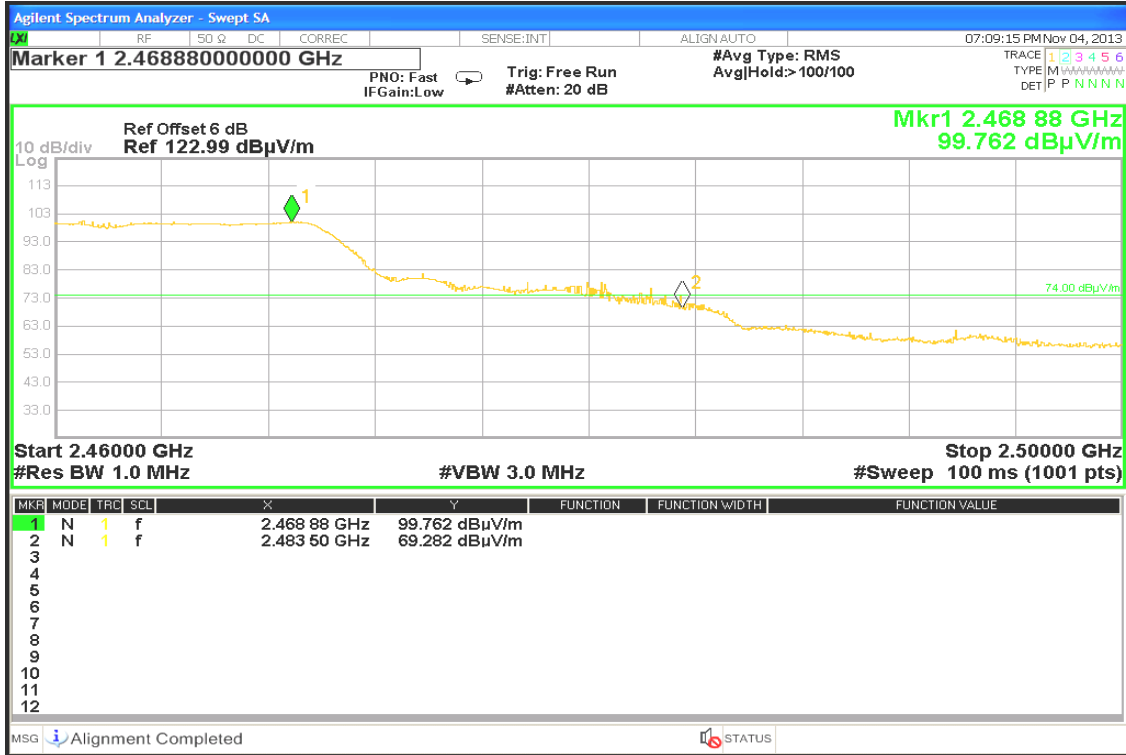

Detector mode: Average

Polarity: Vertical





Detector mode: Peak

Polarity: Horizontal

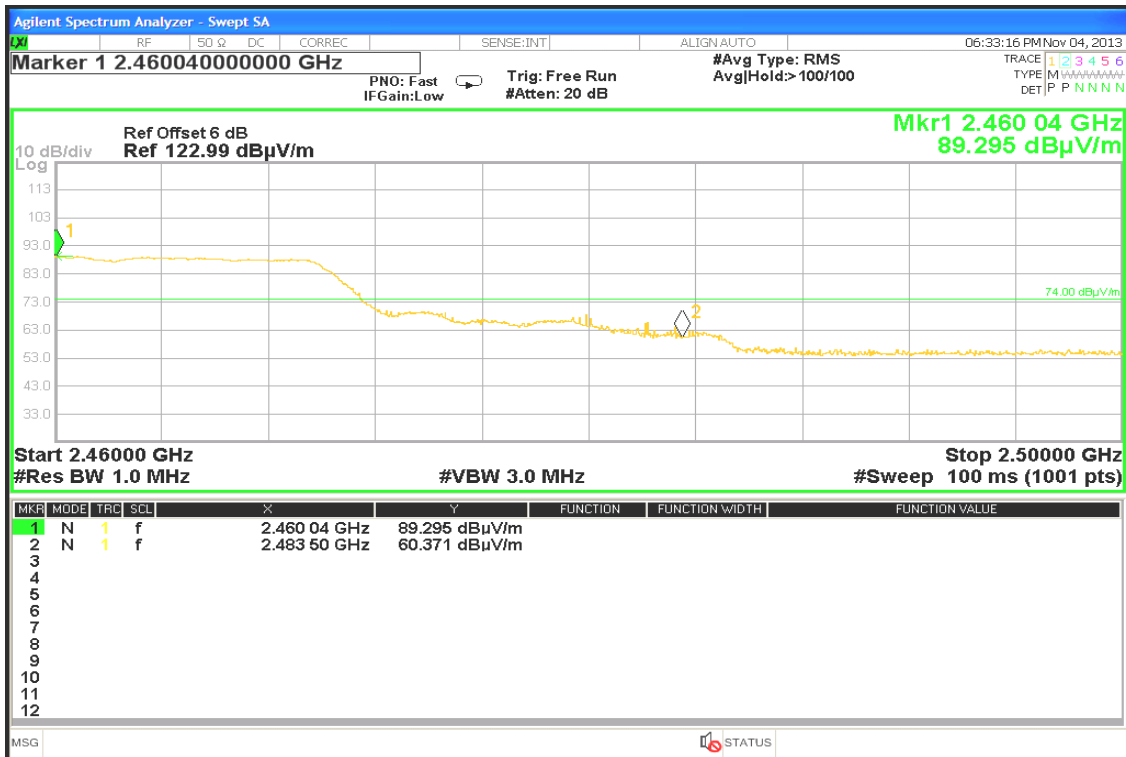

Detector mode: Average

Polarity: Horizontal

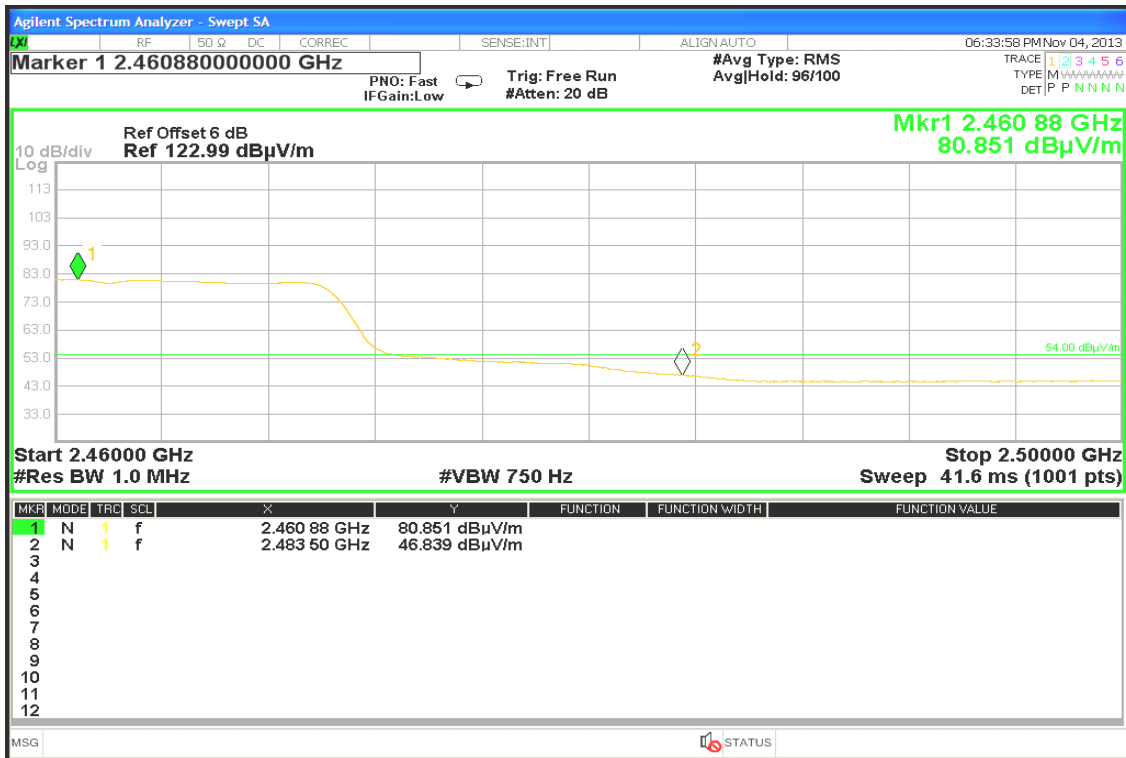



### Band Edges (IEEE 802.11n HT20 mode / CH Low)

Detector mode: Peak

Polarity: Vertical

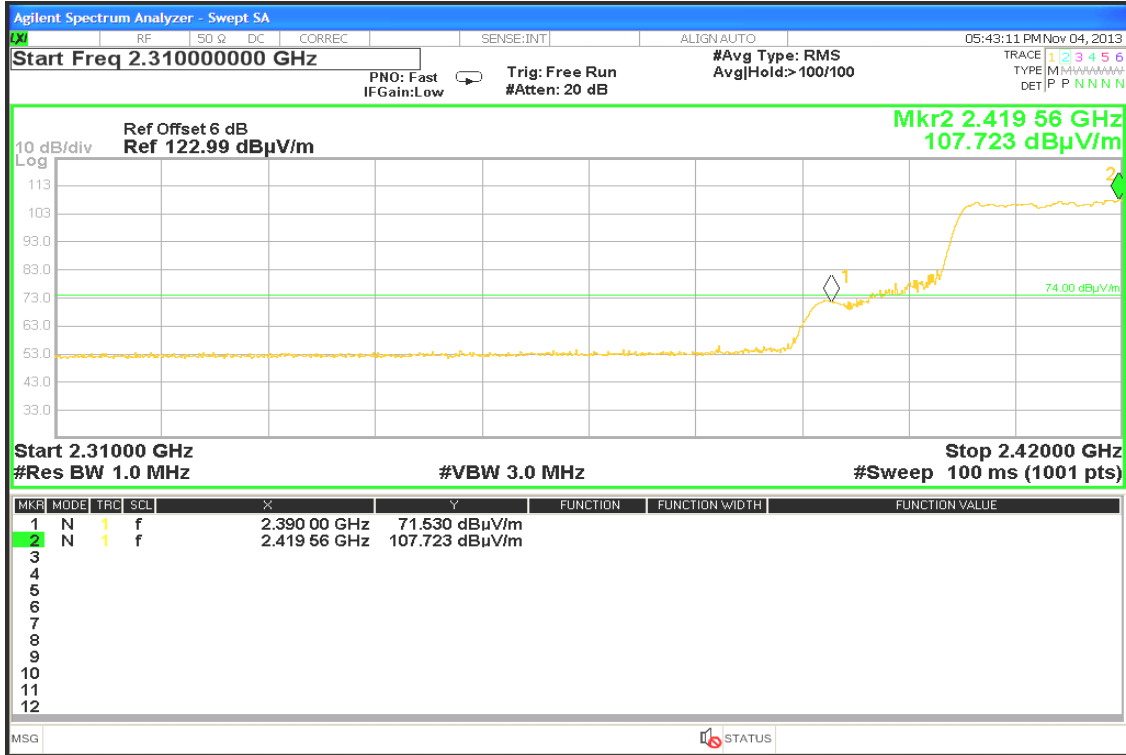

Detector mode: Average

Polarity: Vertical

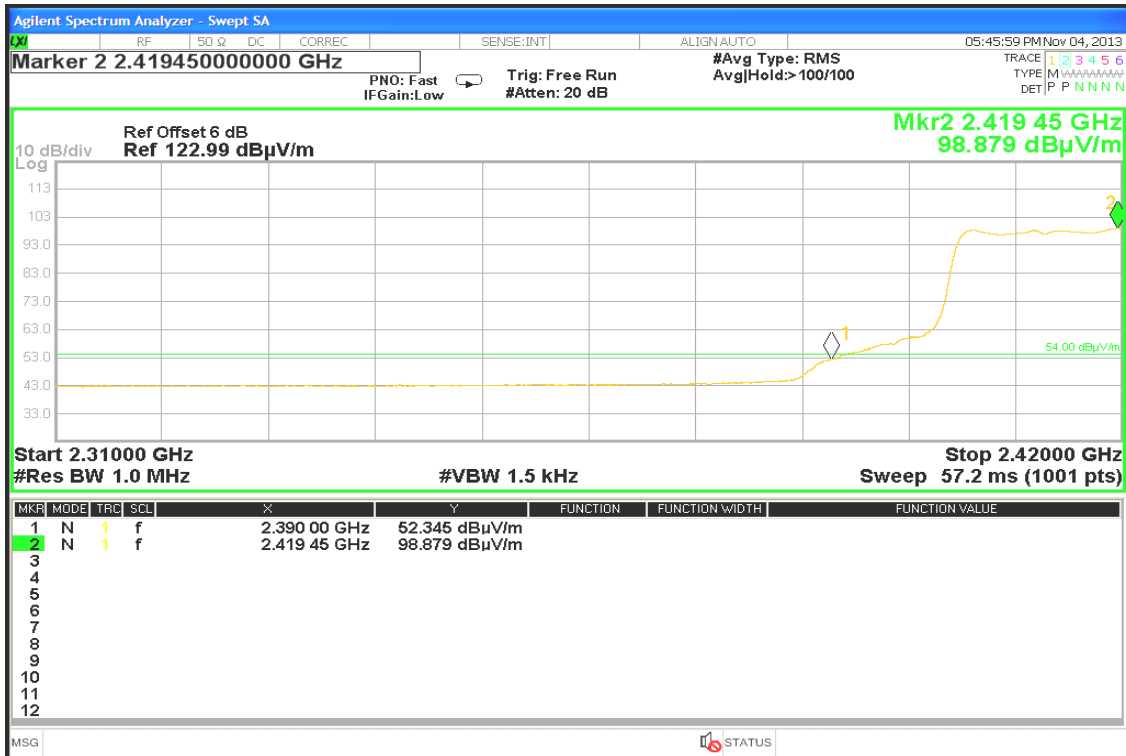



Detector mode: Peak

Polarity: Horizontal

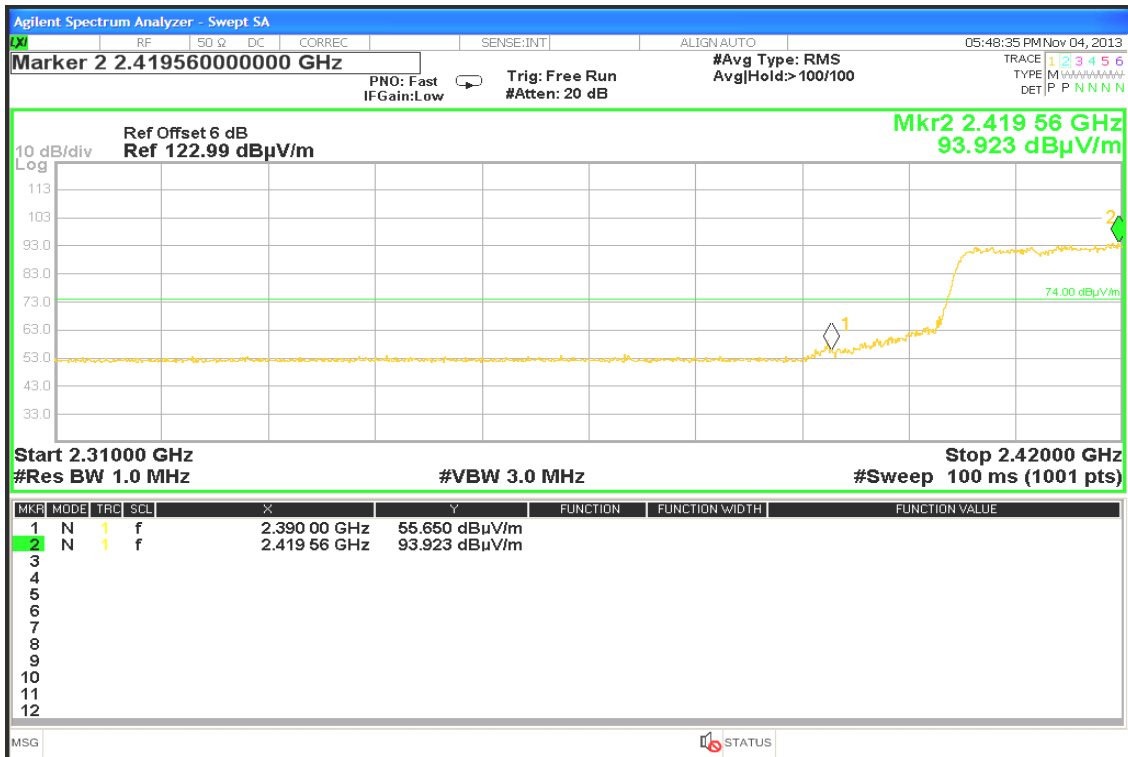

Detector mode: Average

Polarity: Horizontal

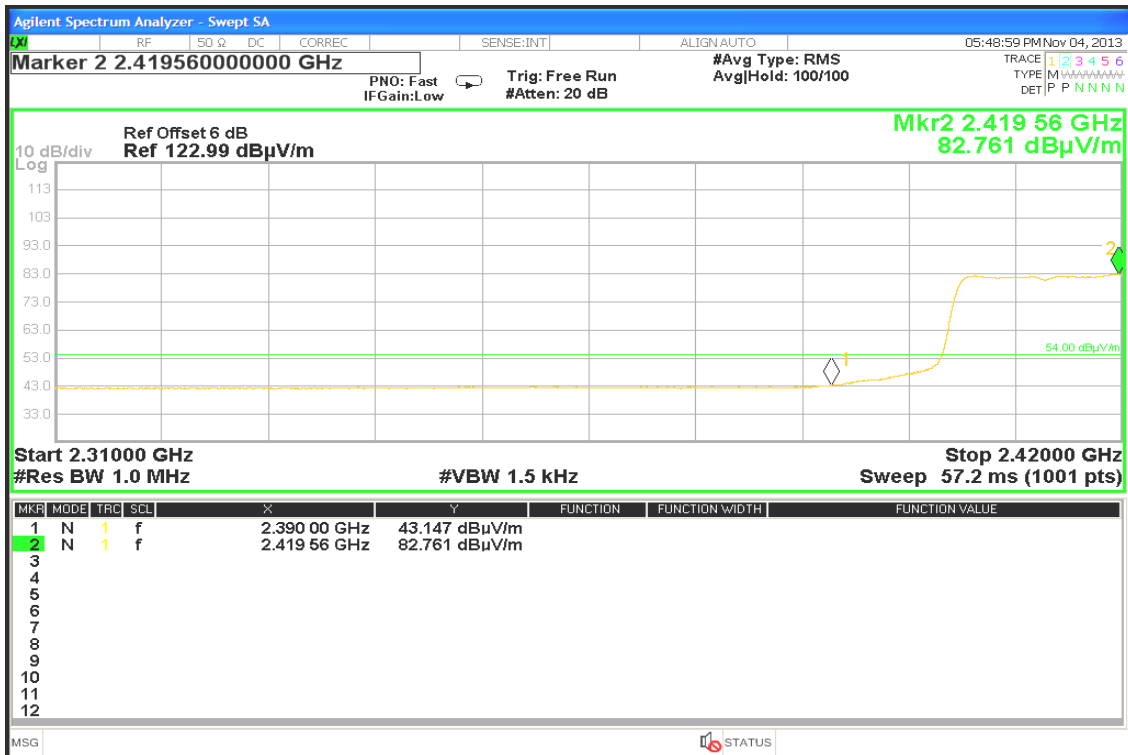



### Band Edges (IEEE 802.11n HT20 mode / CH High)

Detector mode: Peak

Polarity: Vertical

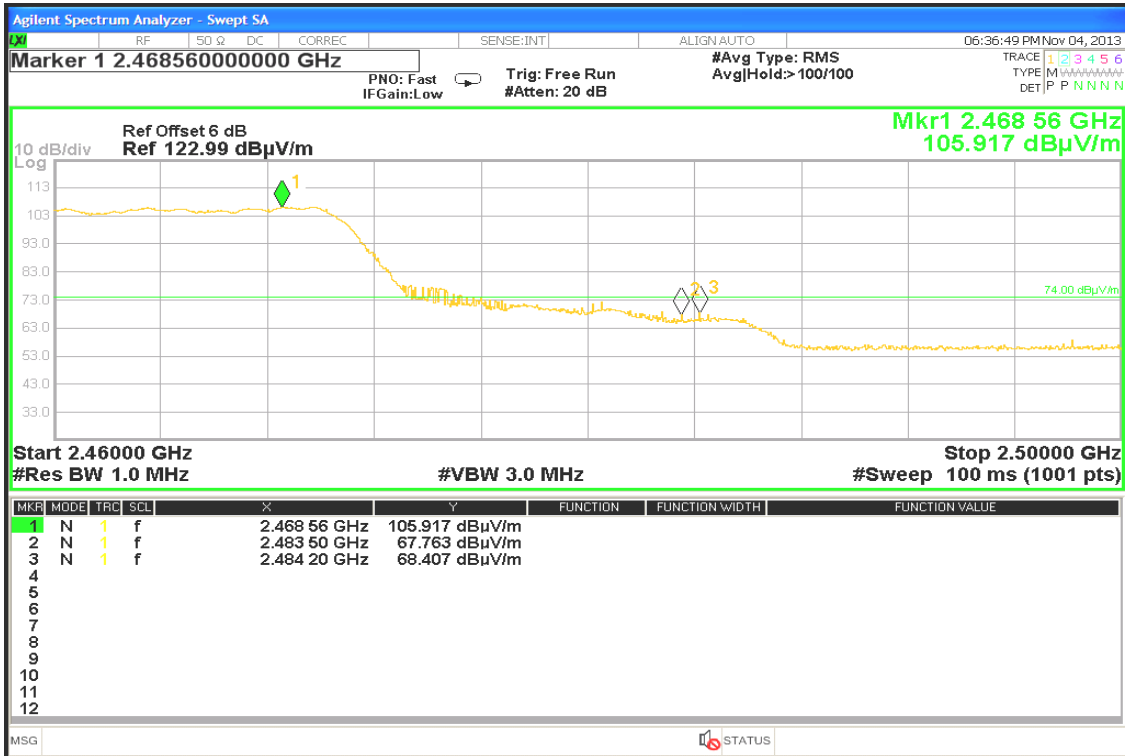

Detector mode: Average

Polarity: Vertical

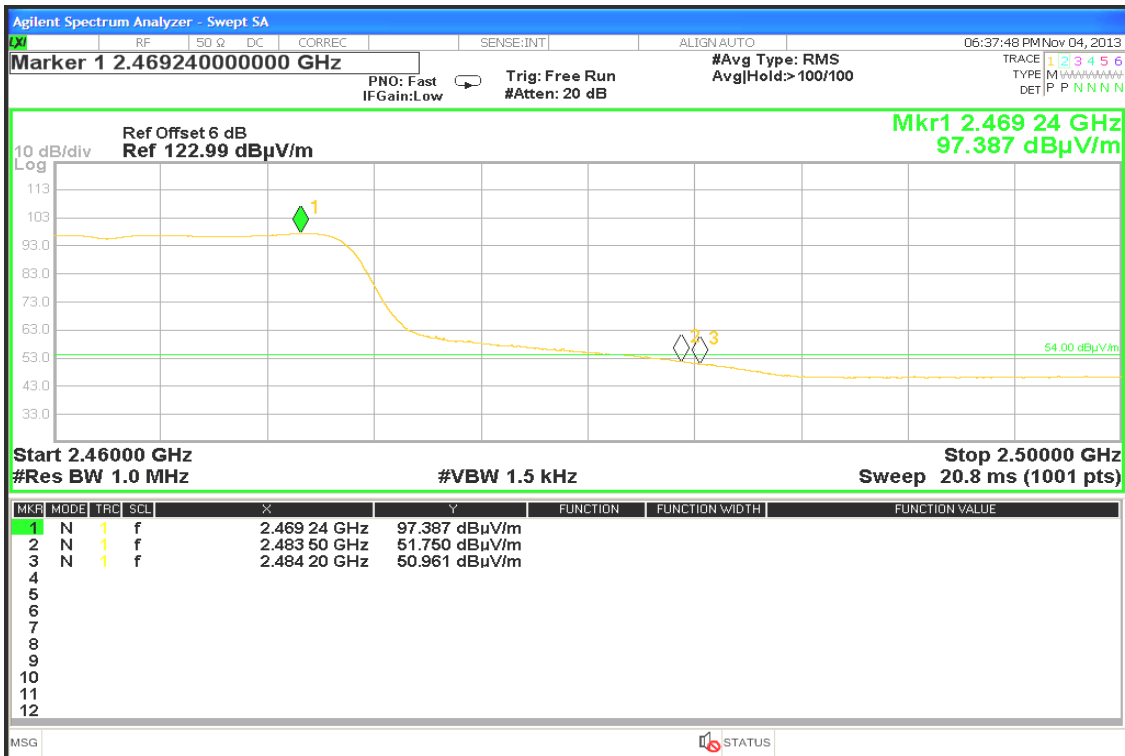





Detector mode: Peak

Polarity: Horizontal

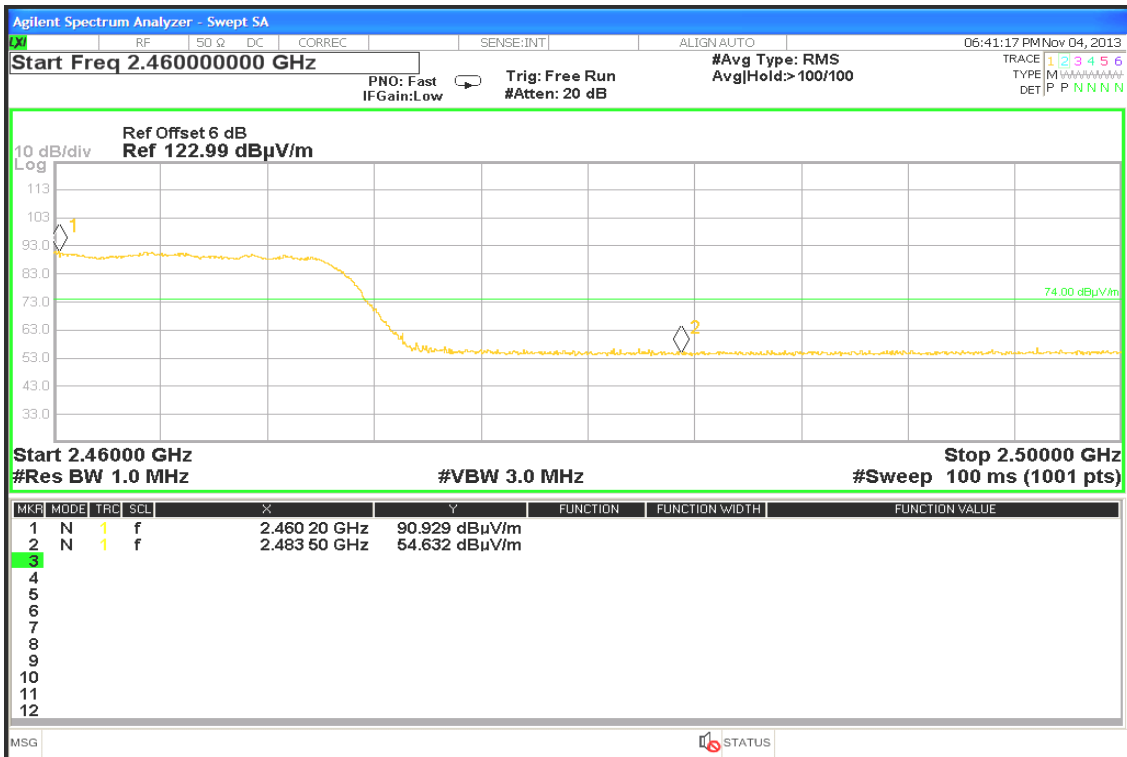

Detector mode: Average

Polarity: Horizontal

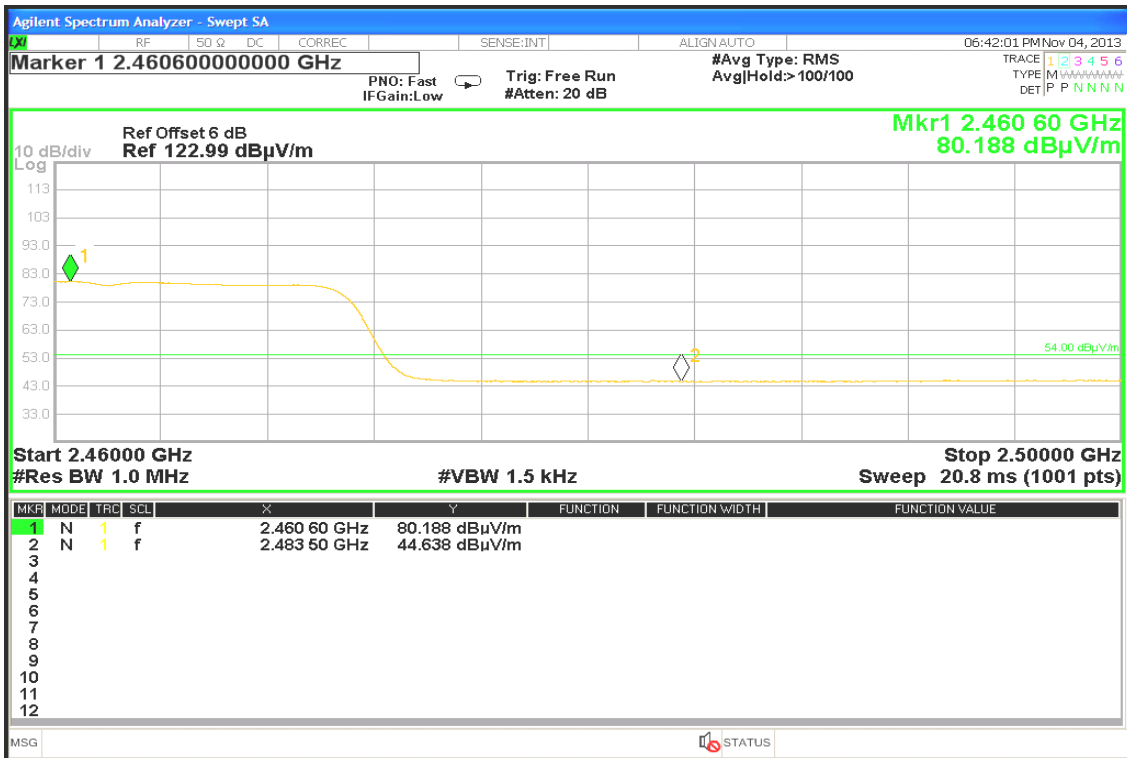



### Band Edges (IEEE 802.11n HT40 mode / CH Low)

Detector mode: Peak

Polarity: Vertical

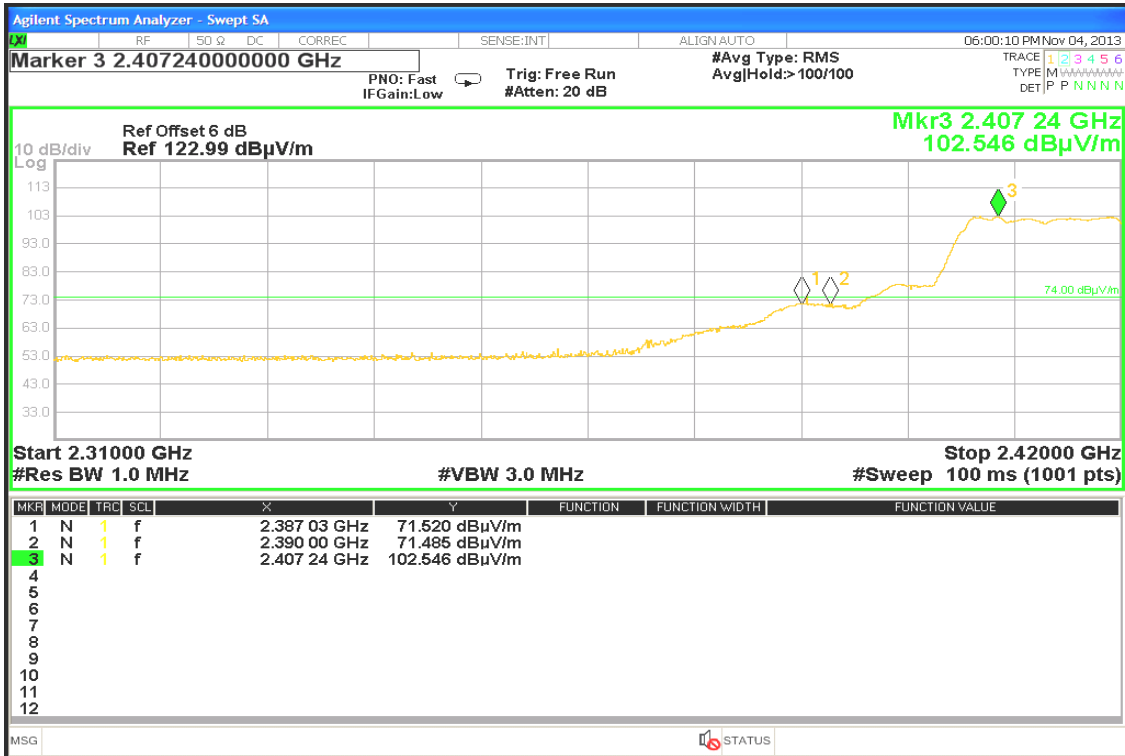

Detector mode: Average

Polarity: Vertical

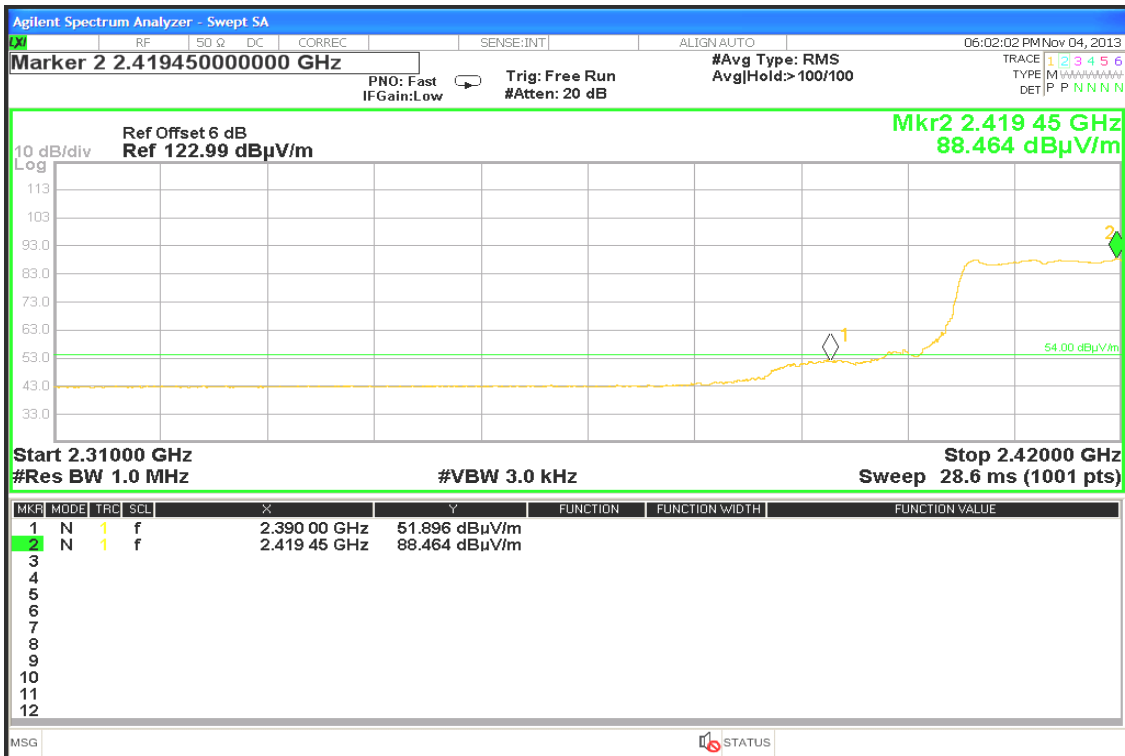



Detector mode: Peak

Polarity: Horizontal

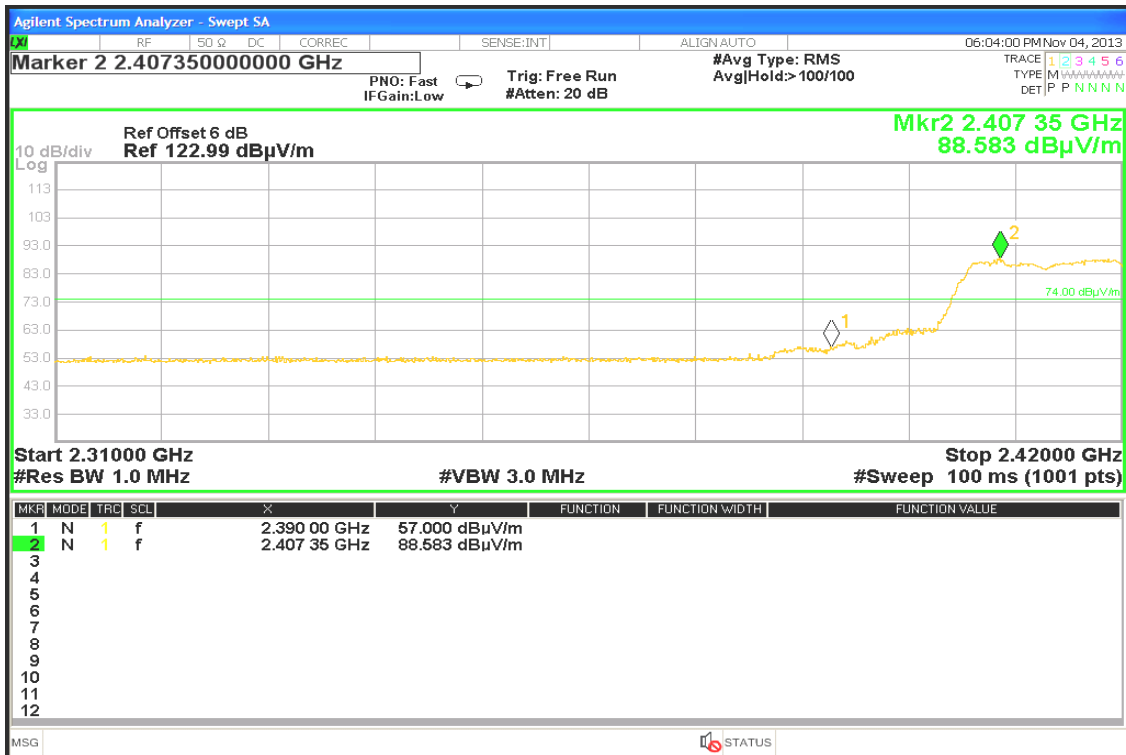

Detector mode: Average

Polarity: Horizontal





### Band Edges (IEEE 802.11n HT40 mode / CH High)

Detector mode: Peak

Polarity: Vertical

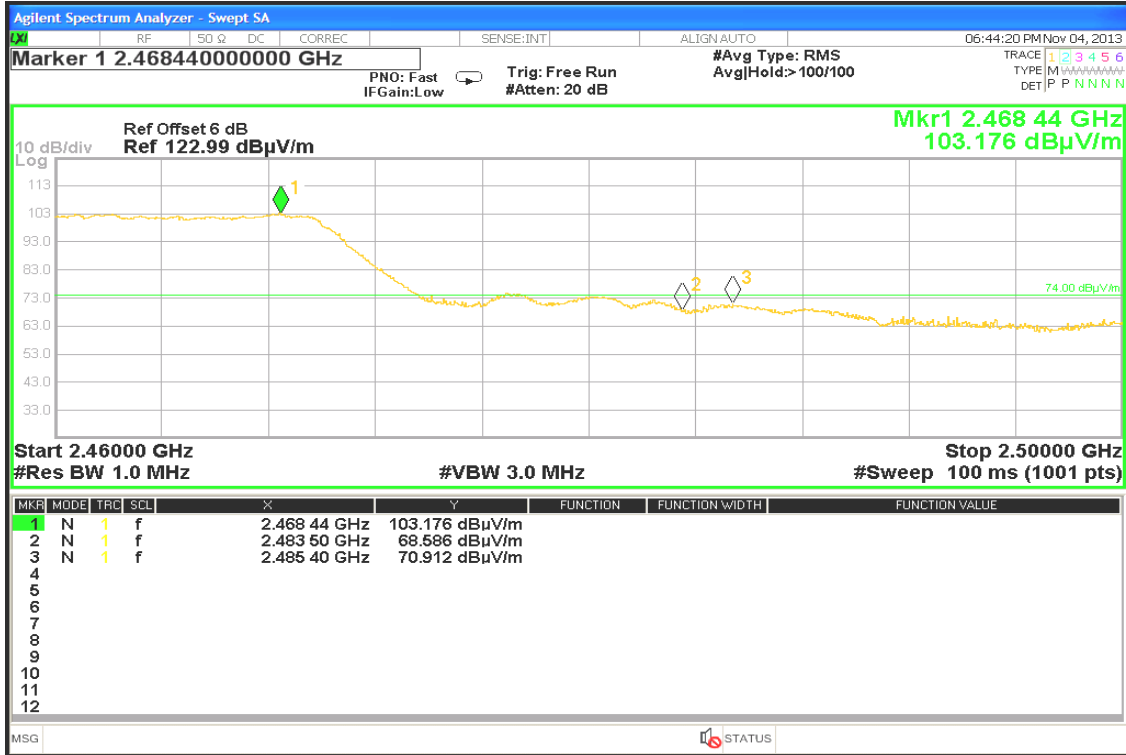

Detector mode: Average

Polarity: Vertical

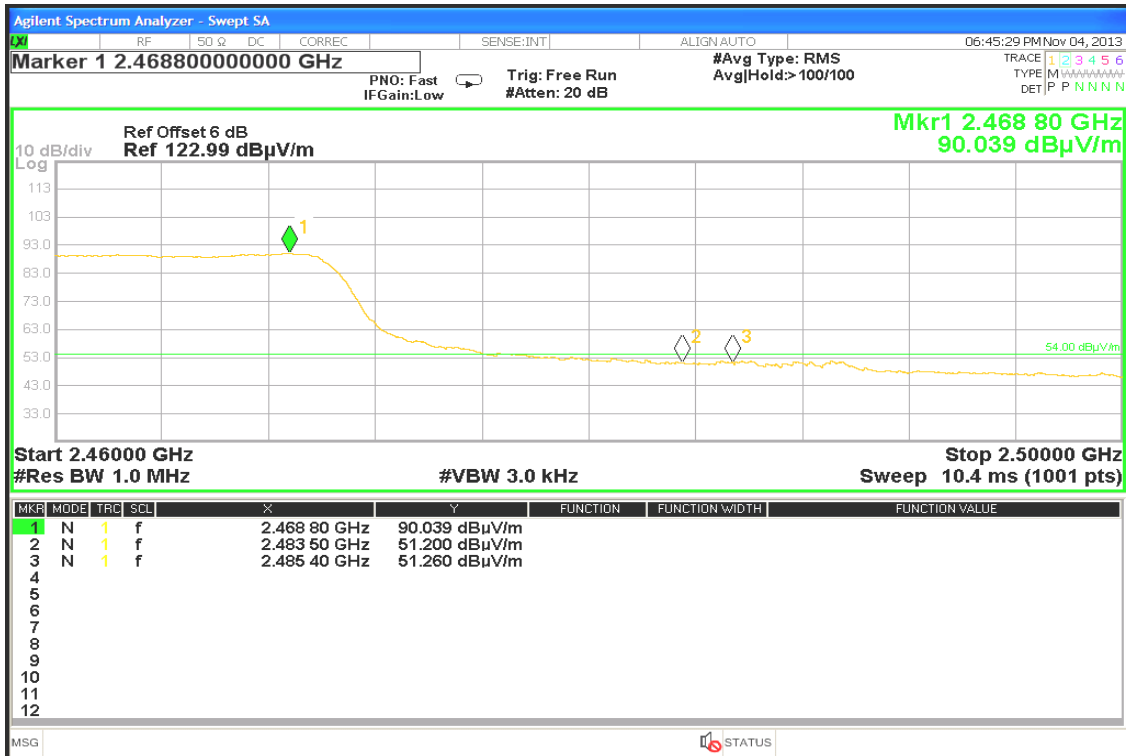



Detector mode: Peak

Polarity: Horizontal

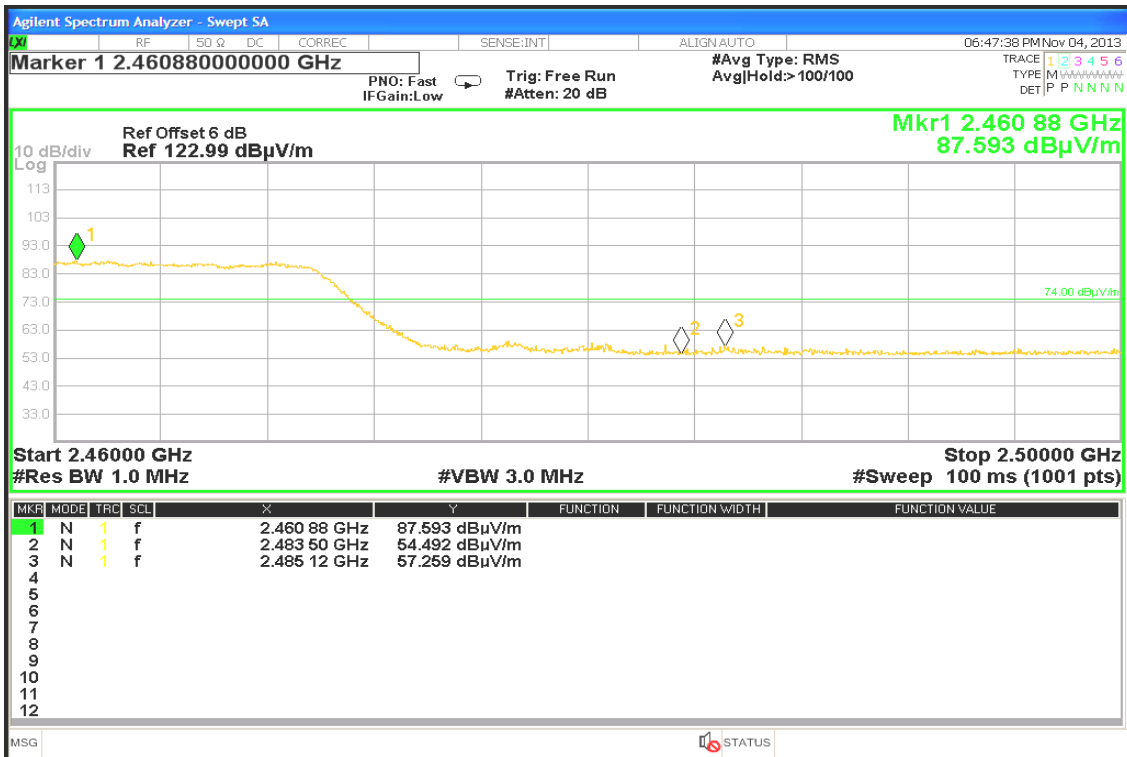

Detector mode: Average

Polarity: Horizontal

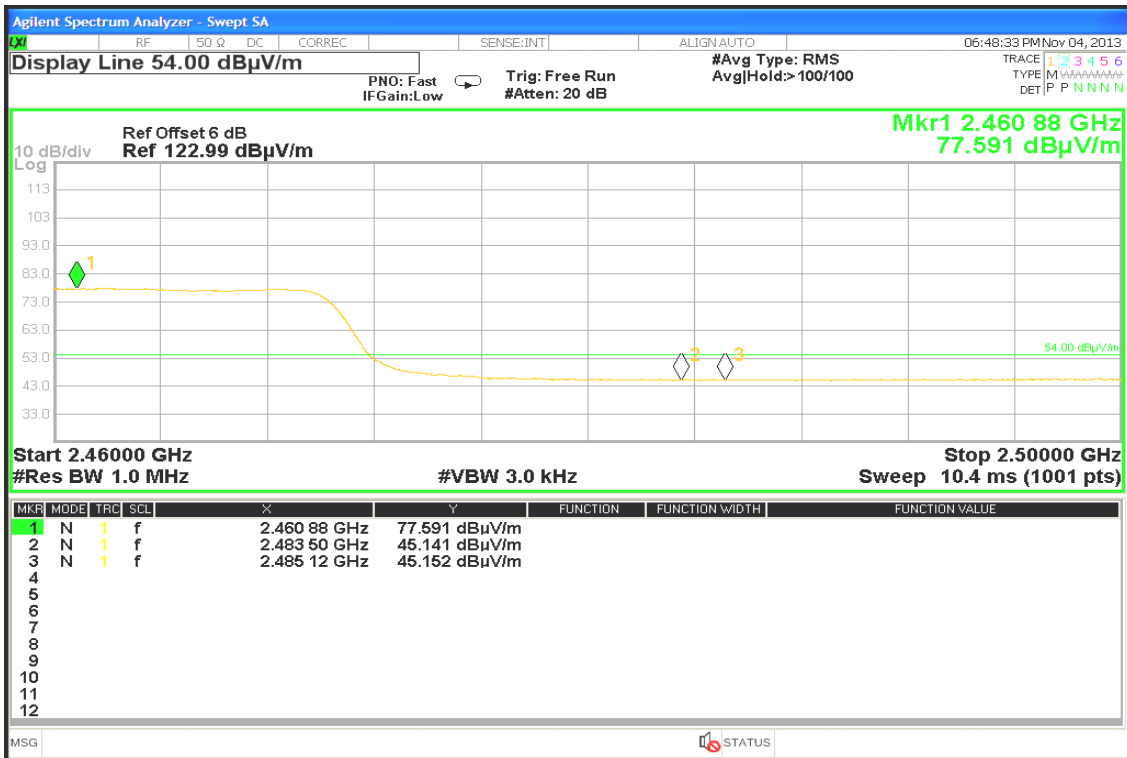



## **7.5 PEAK POWER SPECTRAL DENSITY**

### **LIMIT**

1. According to §15.247(e), for digitally modulated systems, the power spectral density conducted from the intentional radiator to the antenna shall not be greater than 8 dBm in any 3 kHz band during any time interval of continuous transmission.
2. According to §15.247(f), the digital modulation operation of the hybrid system, with the frequency hopping turned off, shall comply with the power density requirements of paragraph (d) of this section.

### **TEST CONFIGURATION**

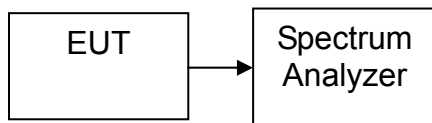

### **TEST PROCEDURE**

#### **Per KDB 558074 D01 DTS Meas Guidance v02**

This procedure must be used if maximum peak conducted output power was used to demonstrate compliance to the fundamental output power limit, and is optional if the maximum (average) conducted output power was used to demonstrate compliance.

1. Set analyzer center frequency to DTS channel center frequency.
2. Set the span to 1.5 times the DTS channel bandwidth.
3. Set the RBW  $\geq$  3 kHz.
4. Set the VBW  $\geq$  3 x RBW.
5. Detector = peak.
6. Sweep time = auto couple.
7. Trace mode = max hold.
8. Allow trace to fully stabilize.

Use the peak marker function to determine the maximum amplitude level.

If measured value exceeds limit, reduce RBW (no less than 3 kHz) and repeat

### **TEST RESULTS**

*No non-compliance noted*



### TEST DATA

#### Test mode: IEEE 802.11b mode

Channel	Frequency (MHz)	PPSD (dBm)	Limit (dBm)	Result
Low	2412	-7.88	8.00	PASS
Mid	2437	-7.95		
High	2462	-7.50		

#### Test mode: IEEE 802.11g mode

Channel	Frequency (MHz)	PPSD (dBm)	Limit (dBm)	Result
Low	2412	-12.15	8.00	PASS
Mid	2437	-9.25		
High	2462	-9.04		

#### Test mode: IEEE 802.11n HT20 mode

Channel	Frequency (MHz)	PPSD (dBm)			Limit (dBm)	Result
		Chain 0	Chain 1	Total		
Low	2412	-13.75	-12.22	-9.91	8.00	PASS
Mid	2437	-12.02	-12.6	-9.29		PASS
High	2462	-13.14	-11.2	-9.05		PASS

#### Test mode: IEEE 802.11n HT40 mode

Channel	Frequency (MHz)	PPSD (dBm)			Limit (dBm)	Result
		Chain 0	Chain 1	Total		
Low	2422	-16.53	-16.76	-13.63	8.00	PASS
Mid	2437	-16.72	-15.30	-12.94		PASS
High	2452	-16.76	-16.02	-13.36		PASS

**Remark:**

1. Total PPSD (dBm) = 10\*LOG(10^(Chain 0 PPSD / 10)+10^(Chain 1 PPSD / 10))
2. The maximum antenna gain is 7.32dB.



**Test Plot**

**IEEE 802.11b mode**

**PPSD (CH Low)**

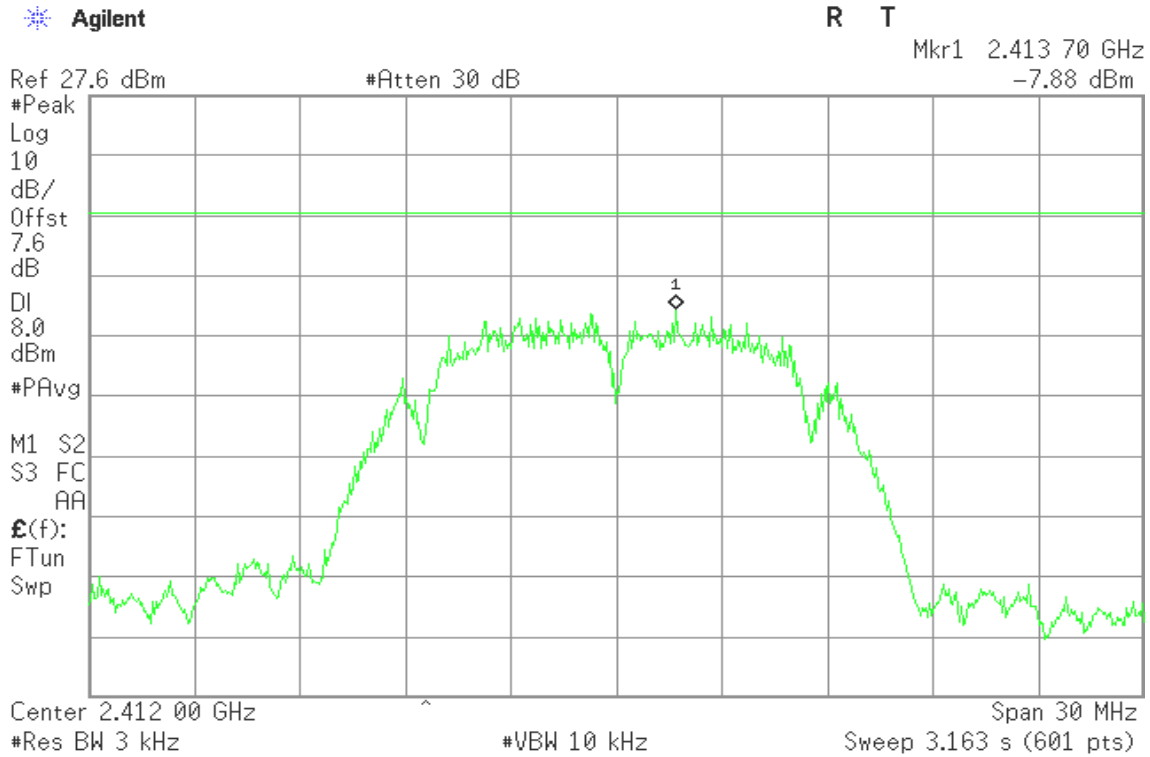

**PPSD (CH Mid)**

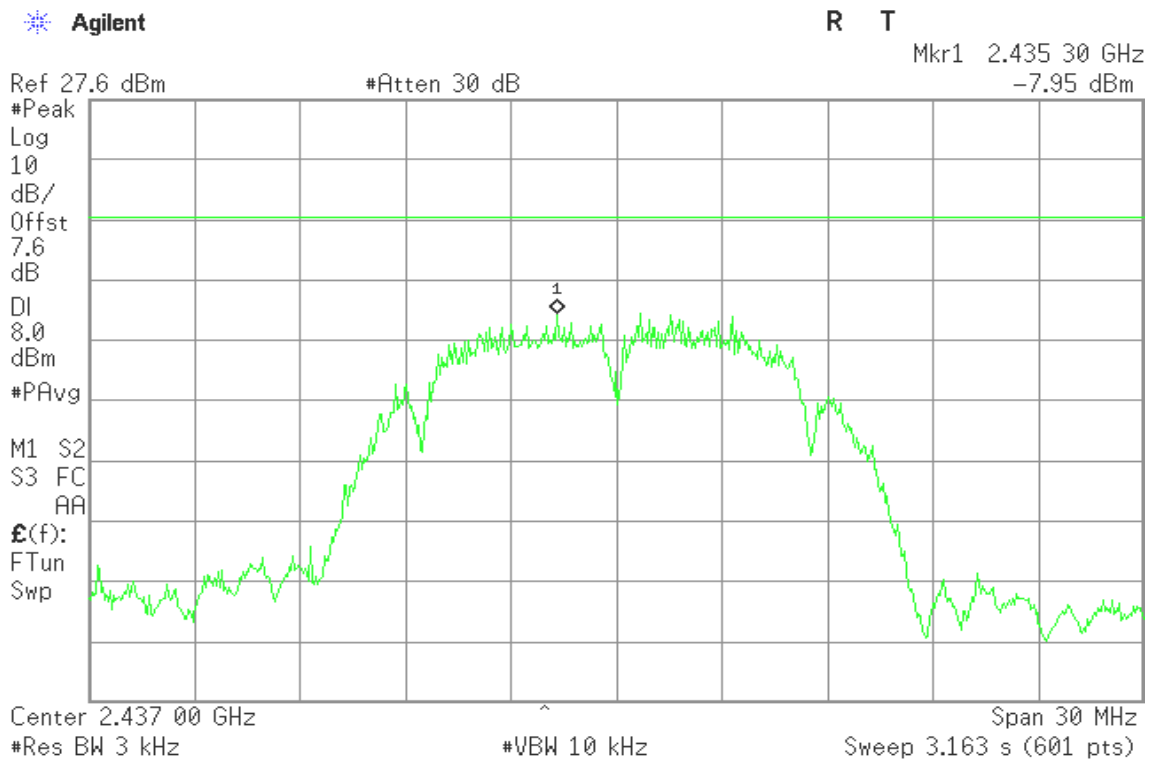





### PPSD (CH High)

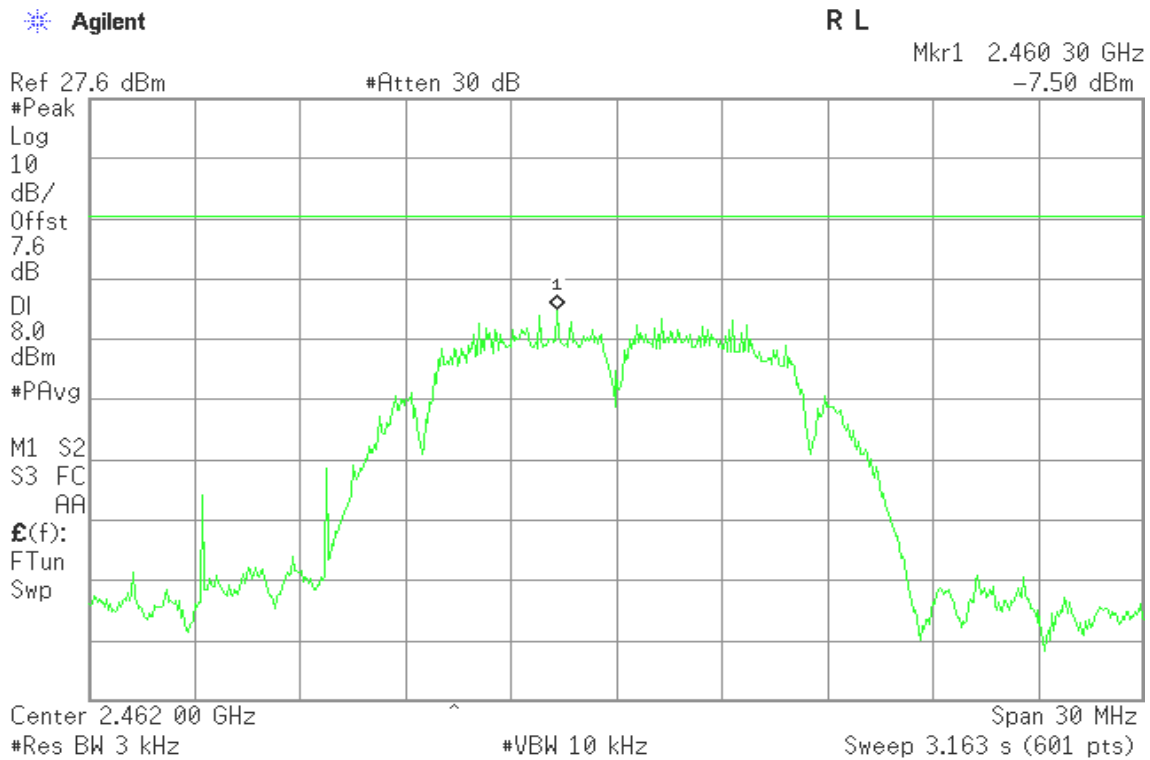

### IEEE 802.11g mode

#### PPSD (CH Low)

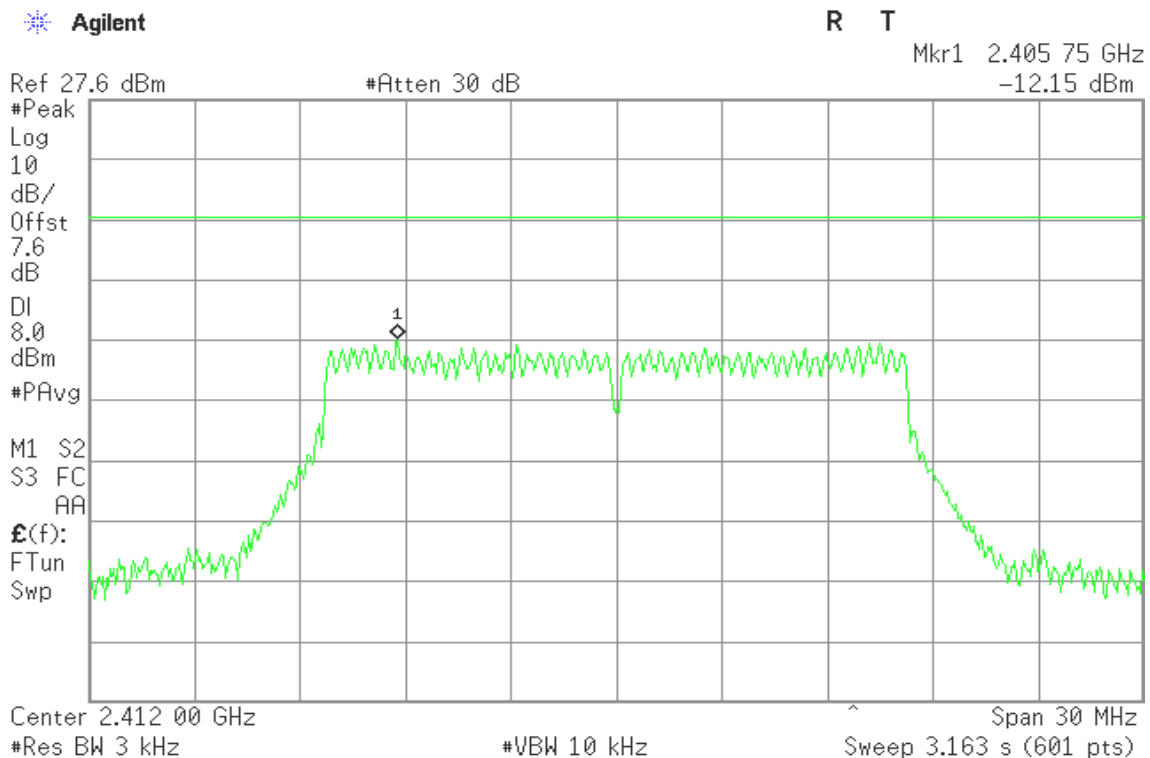



### PPSD (CH Mid)

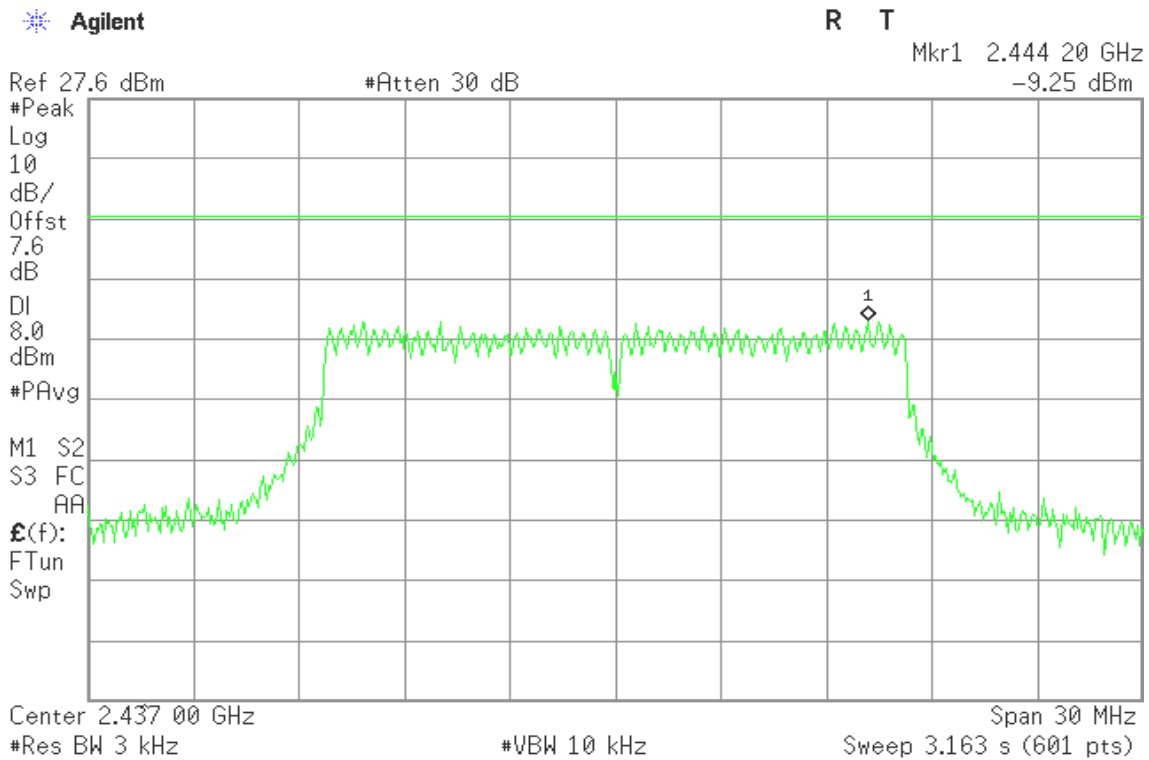

### PPSD (CH High)

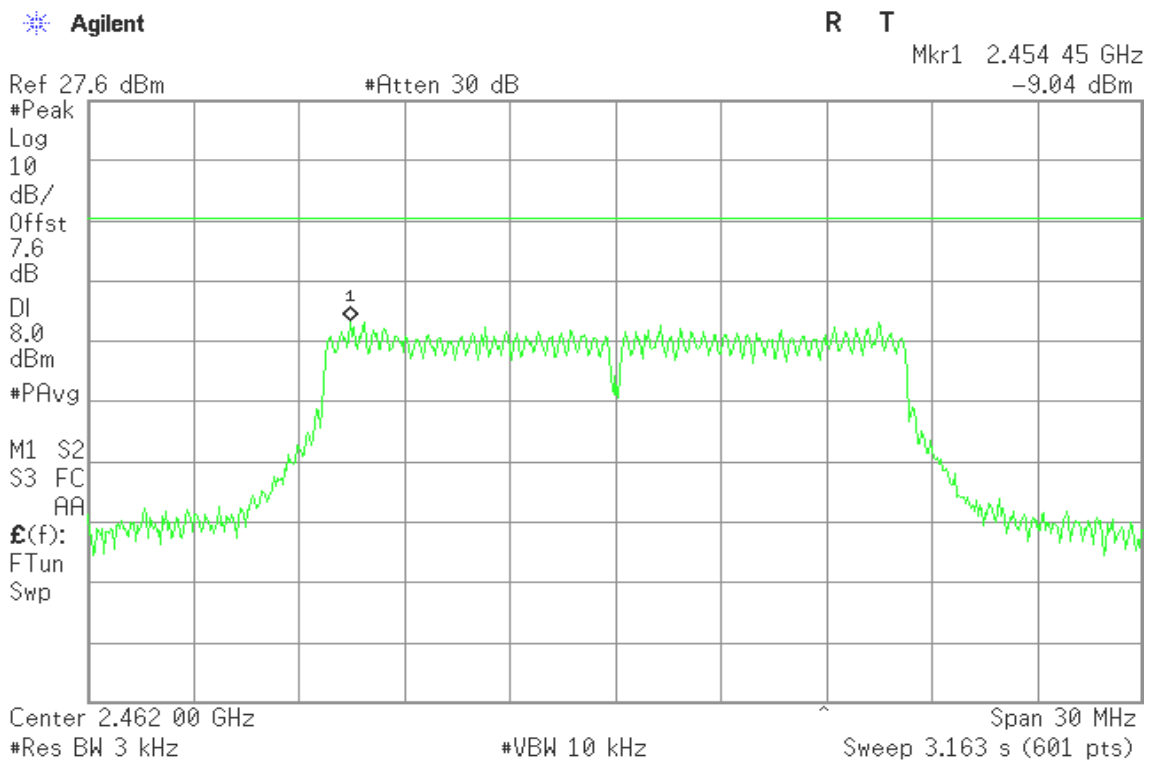



### IEEE 802.11n HT20 mode / Chain 0

#### PPSD (CH Low)

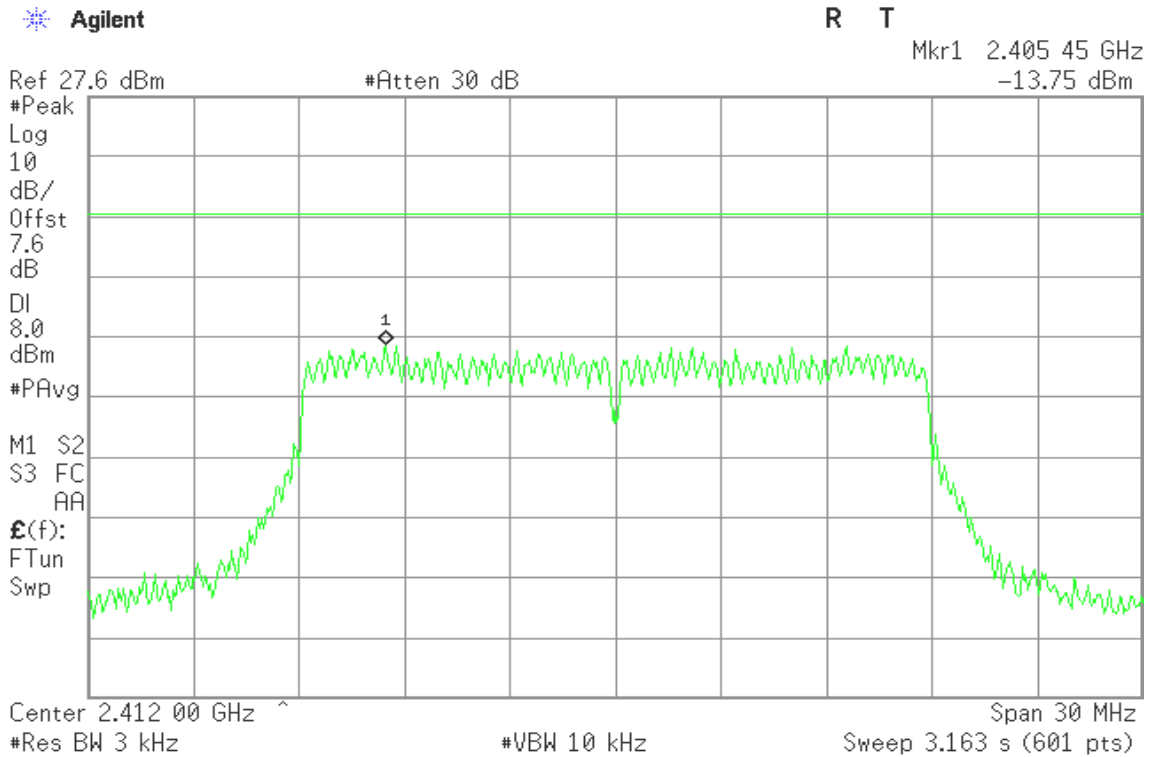

#### PPSD (CH Mid)

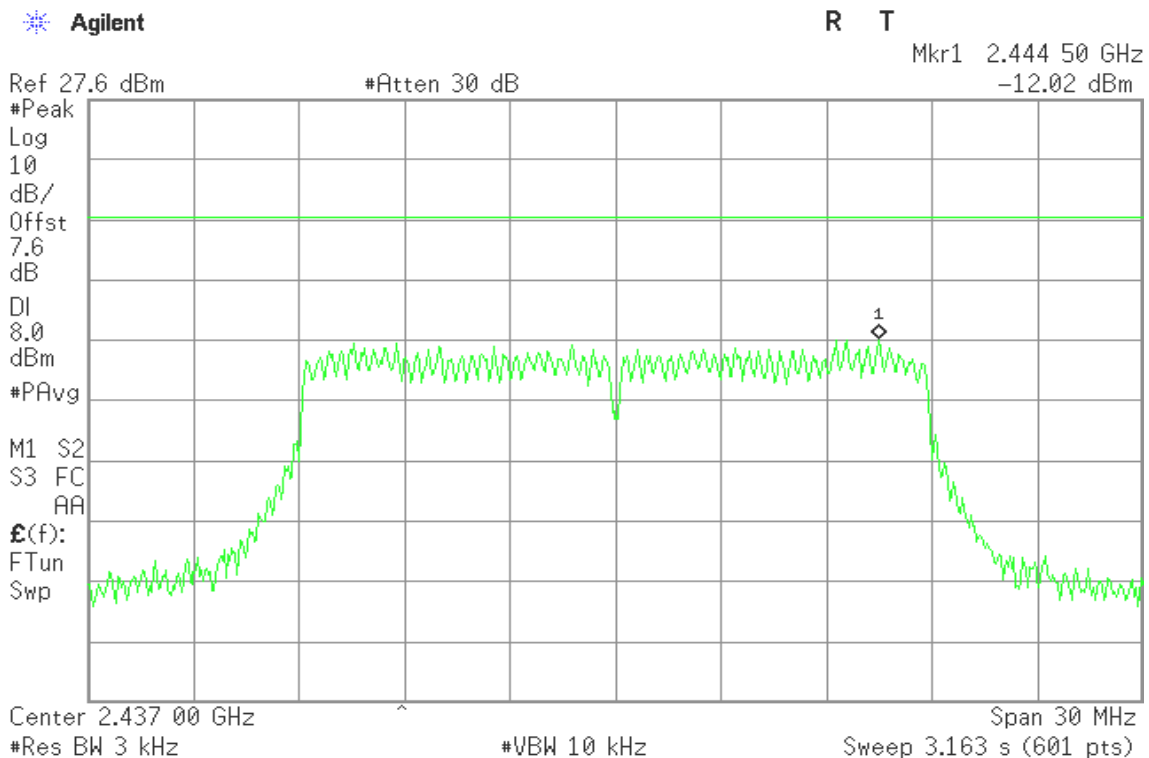



### PPSD (CH High)

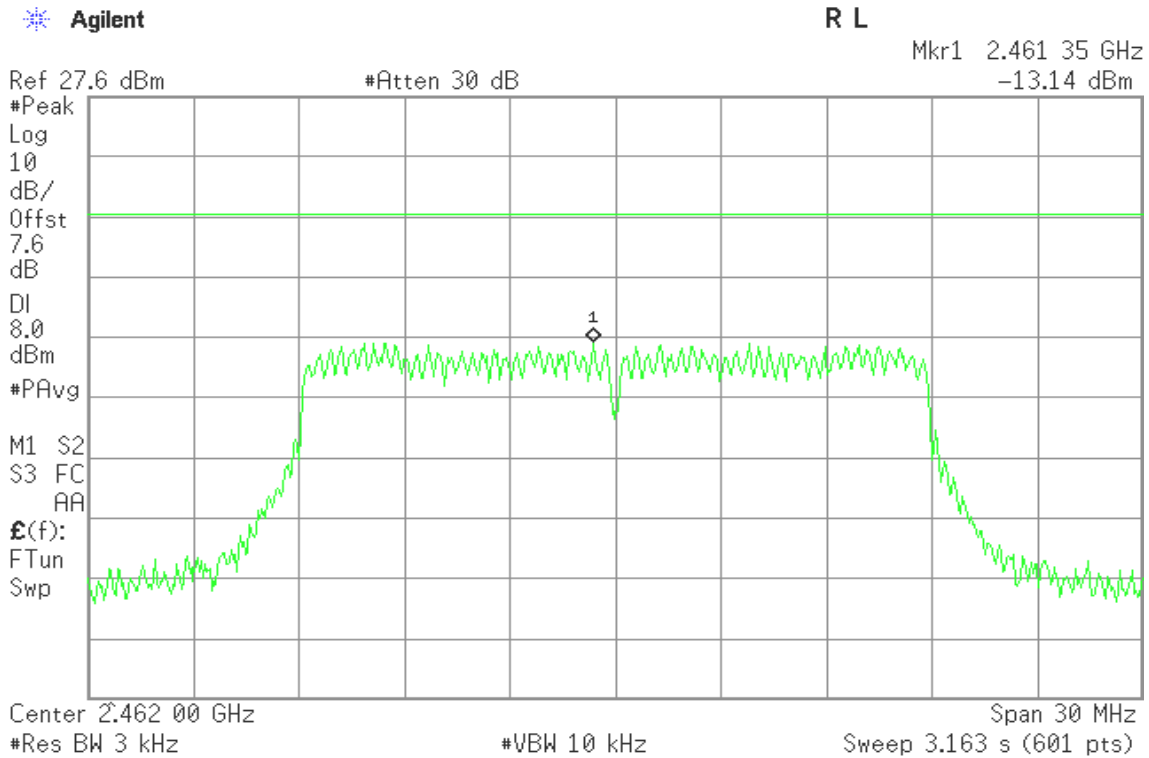

### IEEE 802.11n HT20 mode / Chain 1

#### PPSD (CH Low)

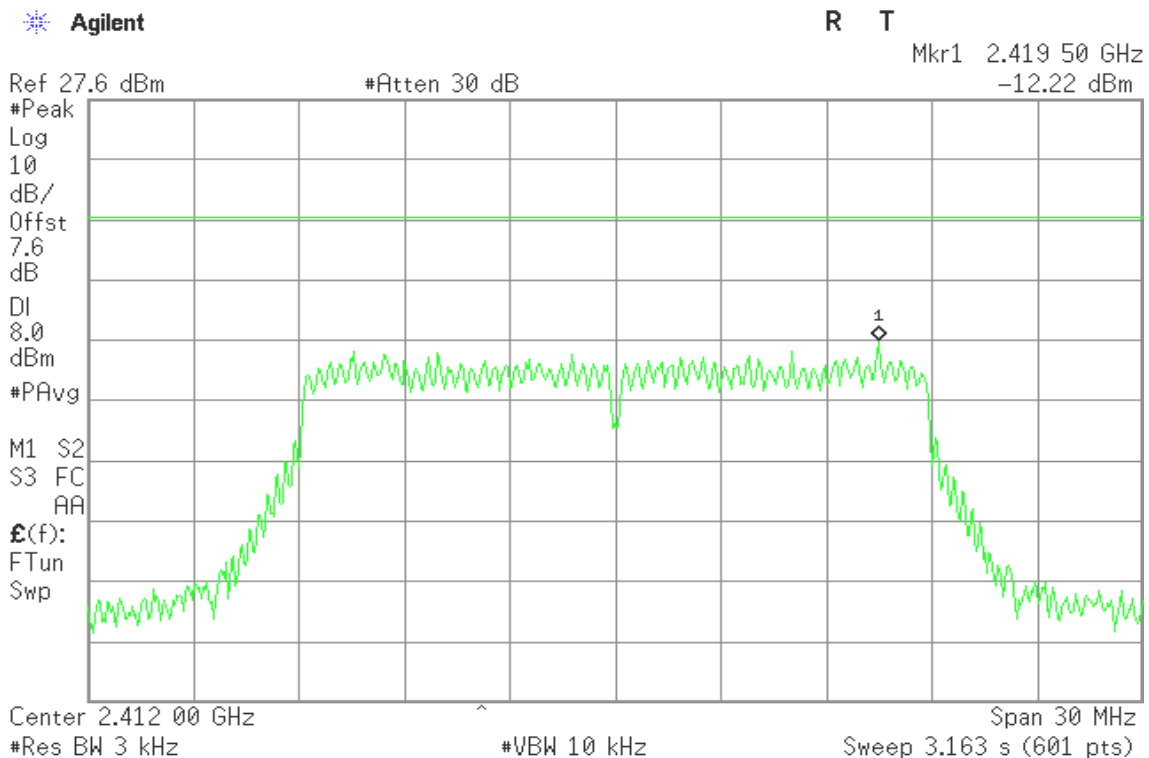



### PPSD (CH Mid)

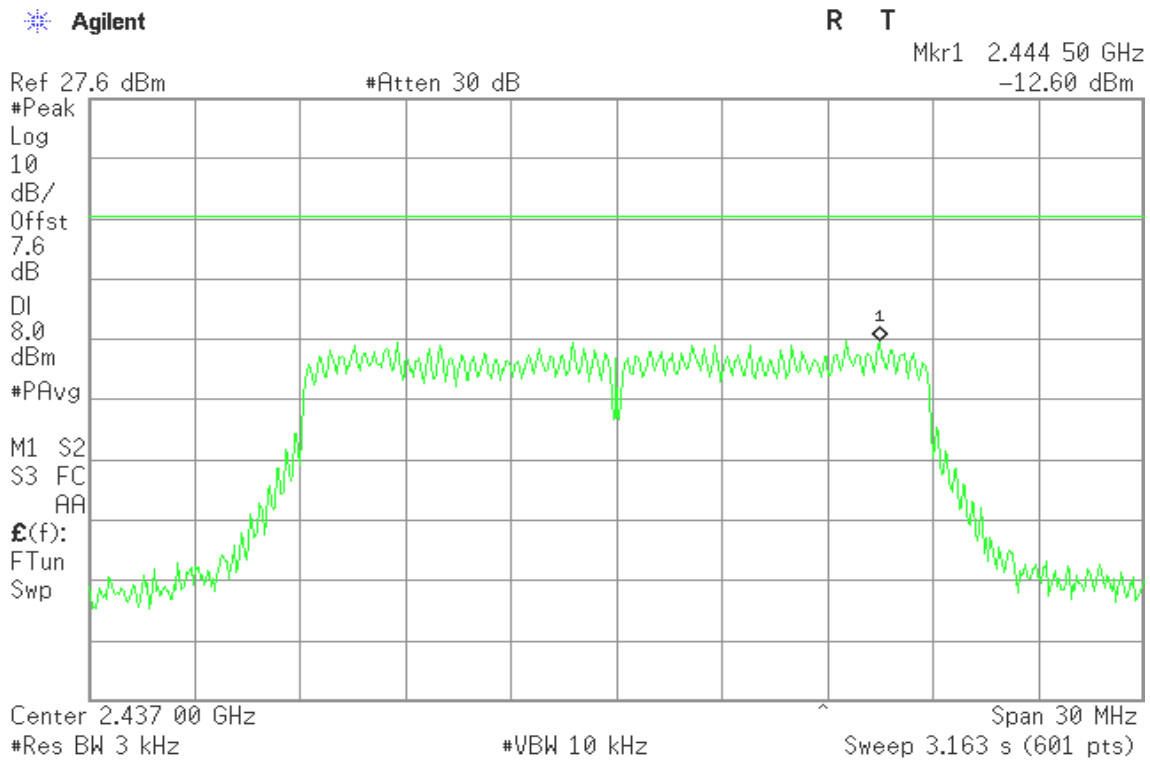

### PPSD (CH High)

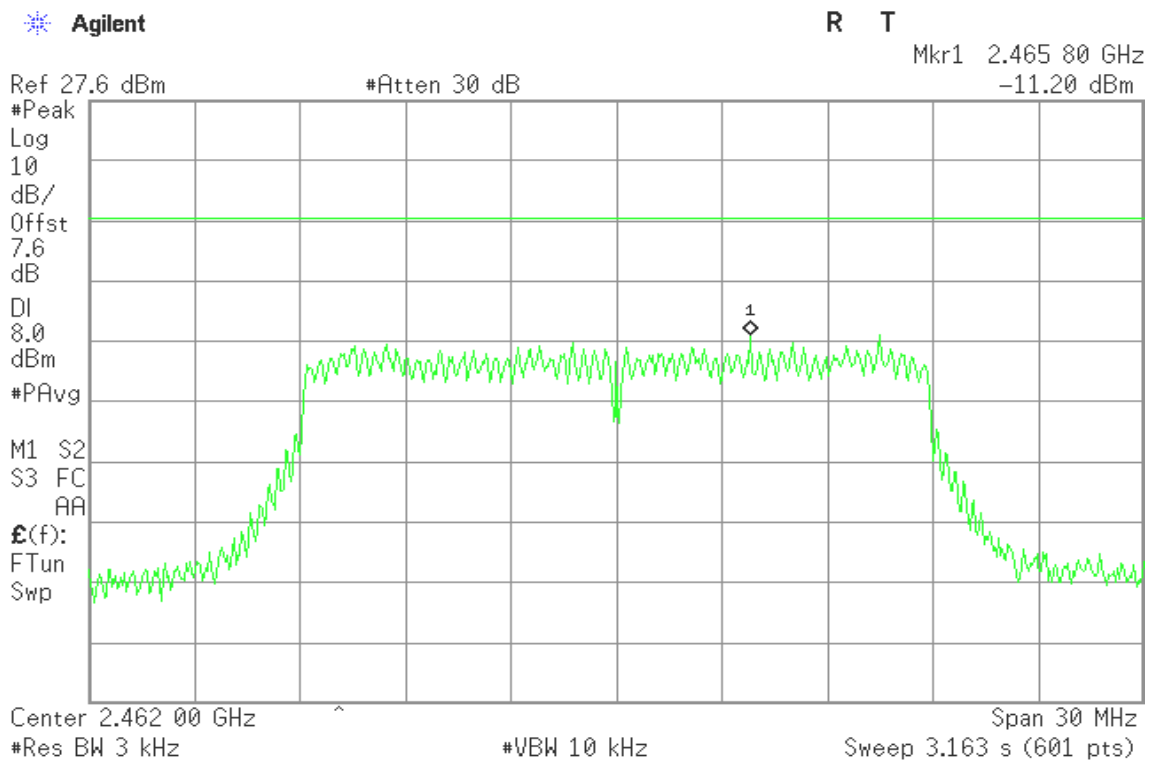



### IEEE 802.11n HT40 mode / Chain 0

#### PPSD (CH Low)

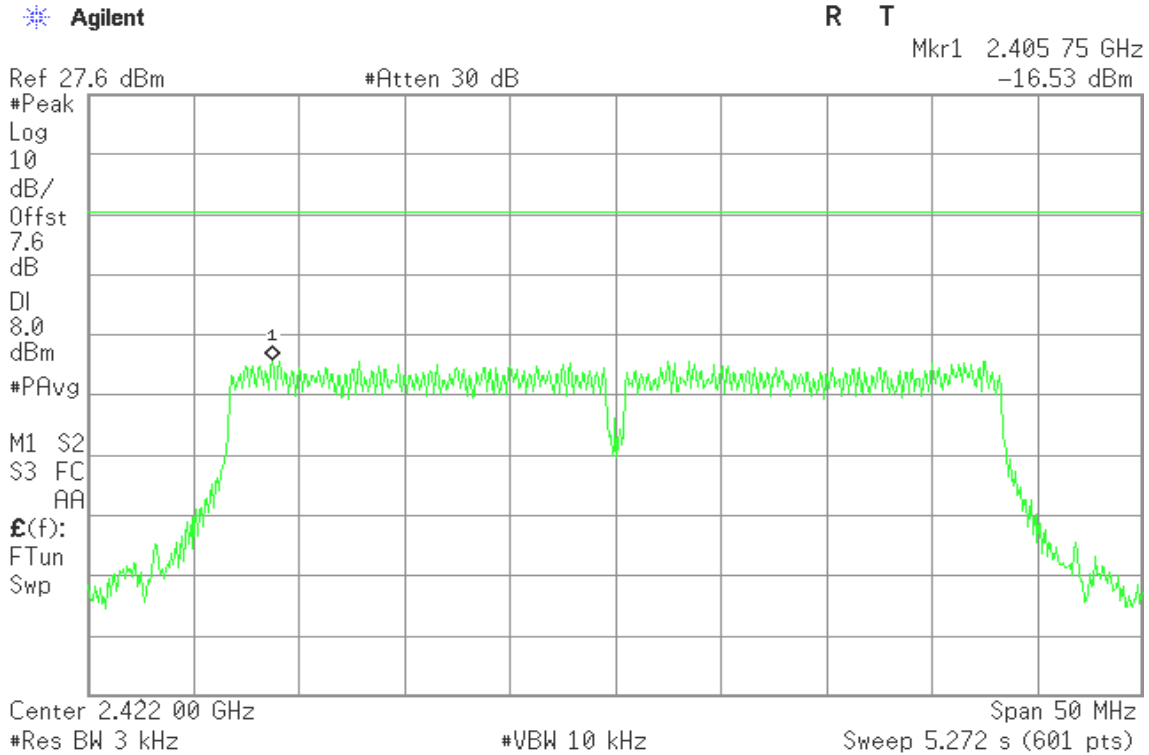

#### PPSD (CH Mid)

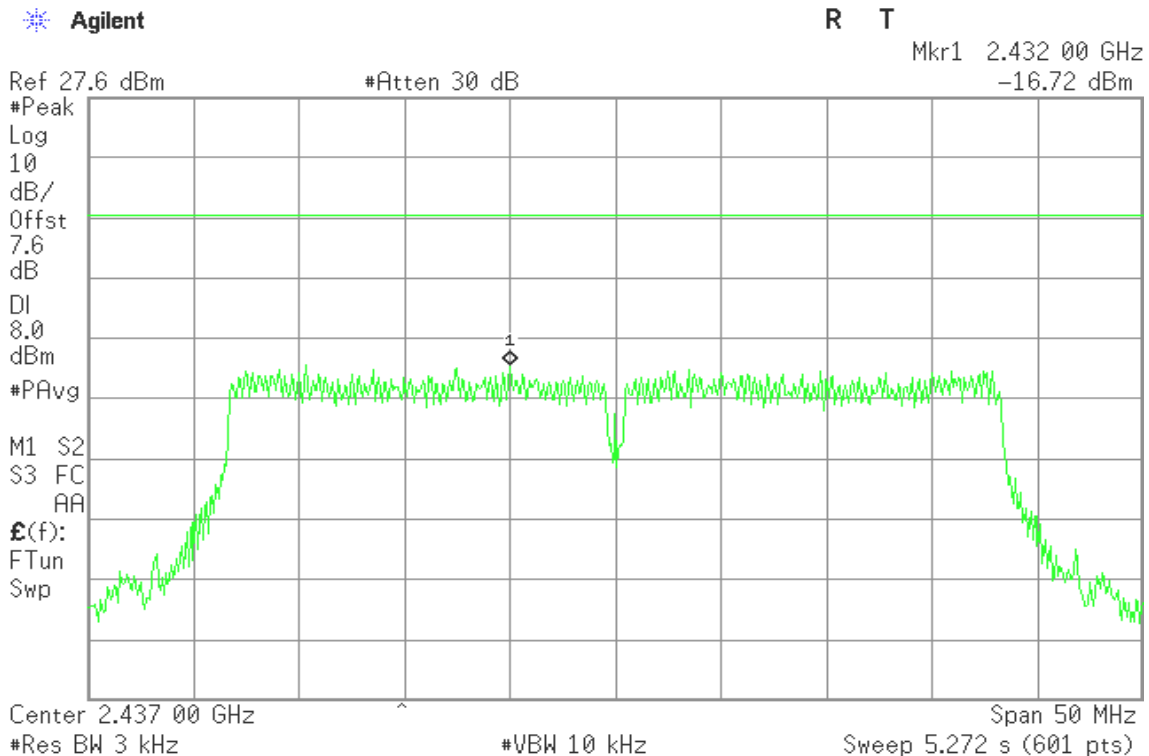



### PPSD (CH High)

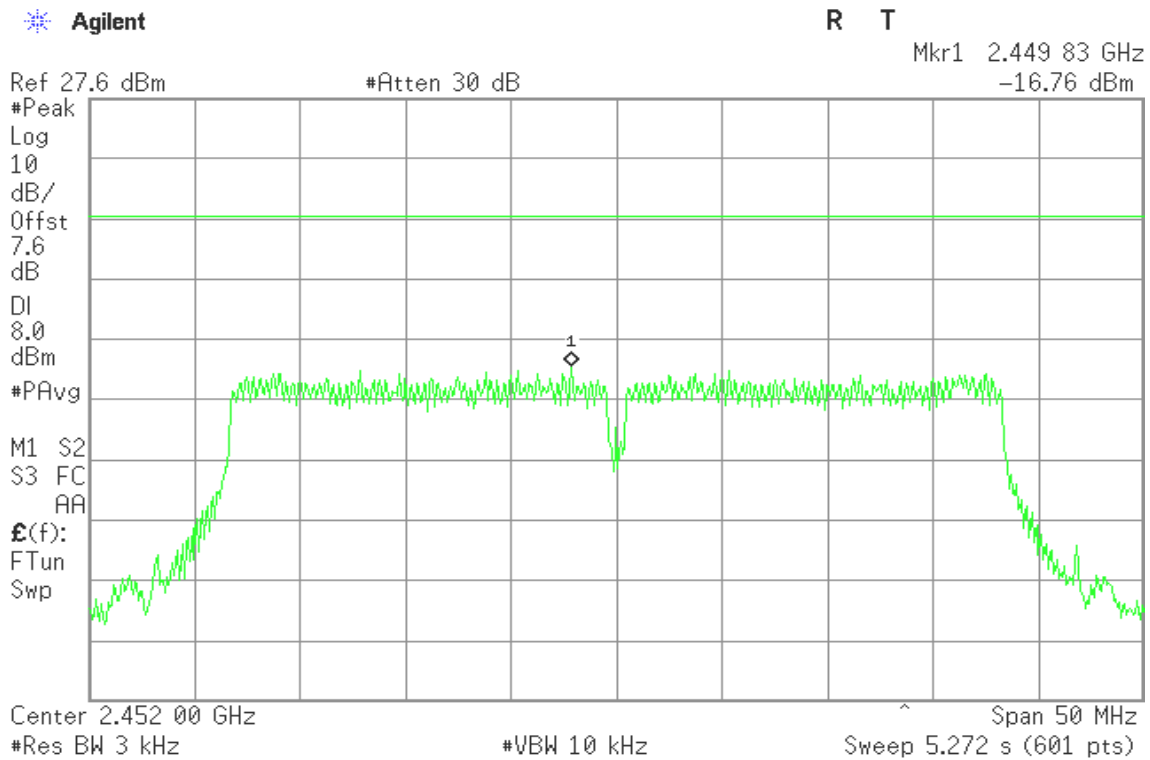

### IEEE 802.11n HT40 mode / Chain 1

#### PPSD (CH Low)

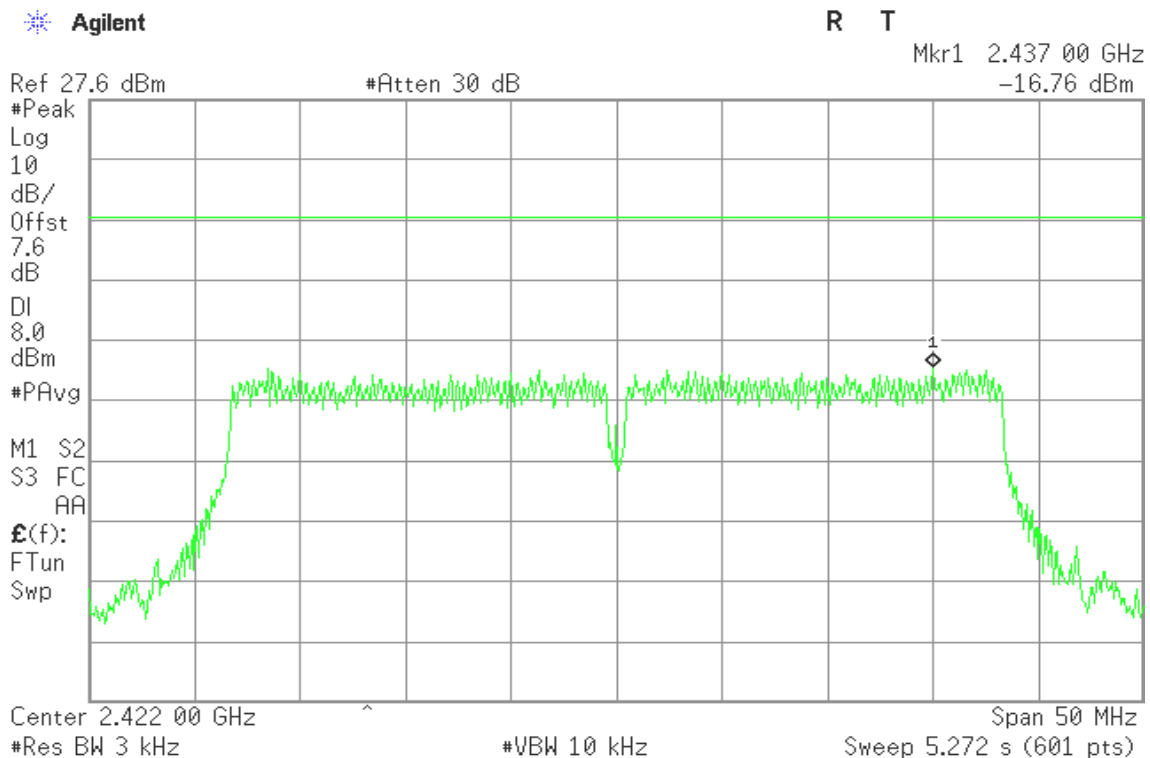



### PPSD (CH Mid)

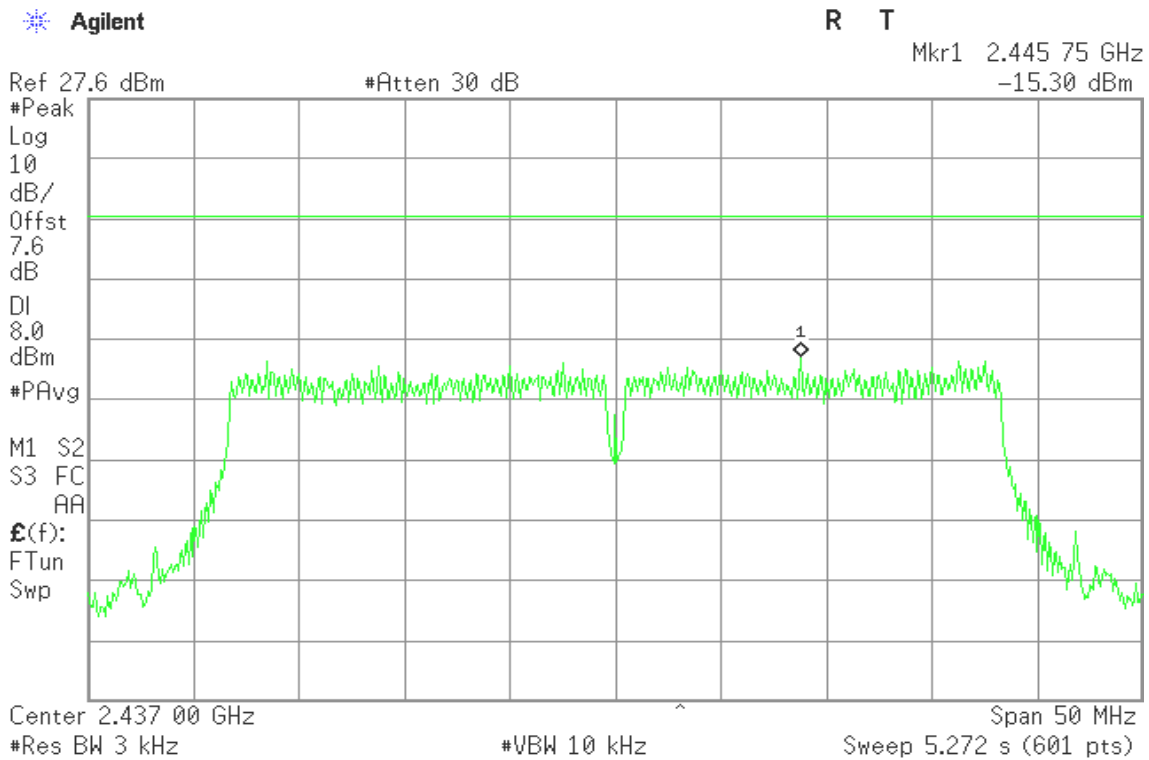

### PPSD (CH High)

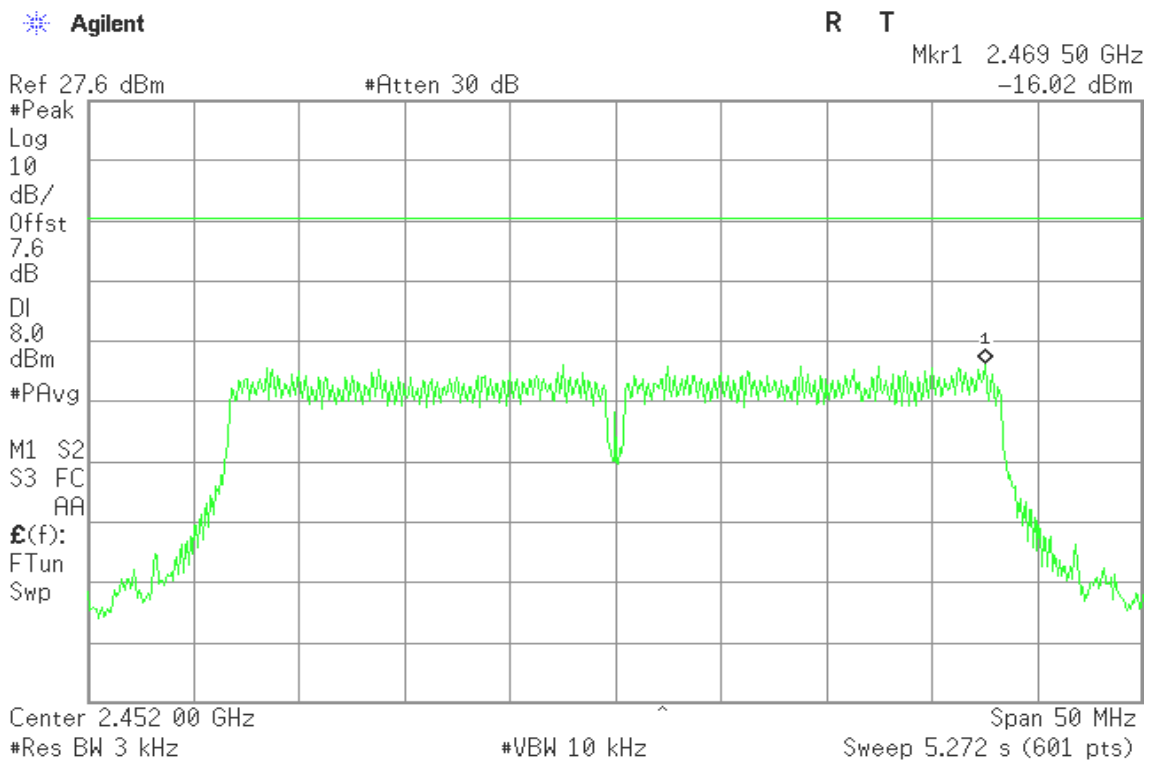





## **7.6 SPURIOUS EMISSIONS**

### **7.6.1 CONDUCTED MEASUREMENT**

#### **LIMIT**

According to §15.247(d), in any 100 kHz bandwidth outside the frequency bands in which the spread spectrum intentional radiator is operating, the radio frequency power that is produced by the intentional radiator shall be at least 20 dB below that in the 100 kHz bandwidth within the band that contains the highest level of the desired power, based on either an RF conducted or a radiated measurement, provided the transmitter demonstrates compliance with the peak conducted power limits. In addition, radiated emissions which fall in the restricted bands, as defined in §15.205(a), must also comply with the radiated emission limits specified in 15.209(a) (see Section 15.205(c)).

#### **TEST CONFIGURATION**

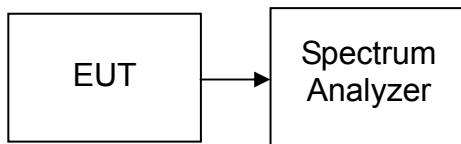

#### **TEST PROCEDURE**

*Per KDB 662911 D01 Multiple Transmitter Output v01r02*

Conducted RF measurements of the transmitter output were made to confirm that the EUT antenna port conducted emissions meet the specified limit and to identify any spurious signals that require further investigation or measurements on the radiated emissions site.

The transmitter output is connected to the spectrum analyzer. The resolution bandwidth is set to 100 kHz. The video bandwidth is set to 100 kHz.

Measurements are made over the 30MHz to 26GHz range with the transmitter set to the lowest, middle, and highest channels.

#### **TEST RESULTS**

*No non-compliance noted.*



### Test Plot

### Spurious Emissions

### IEEE 802.11b mode

### CH Low

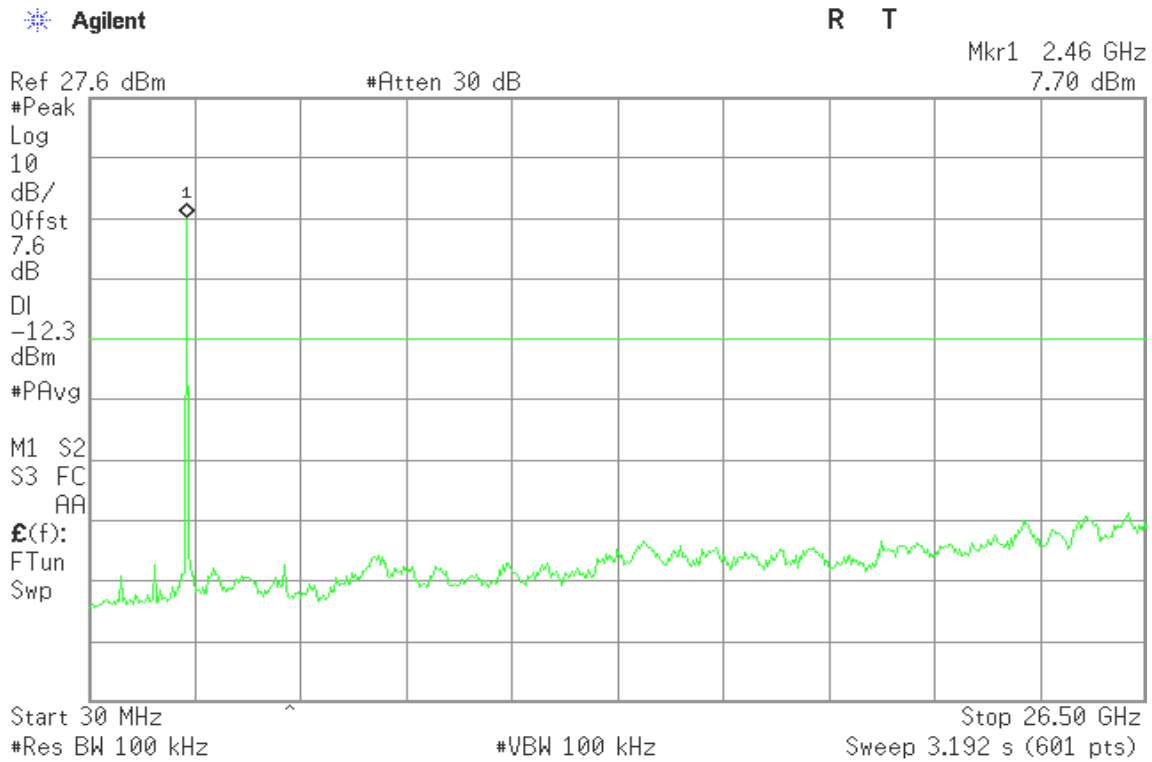

### CH Mid

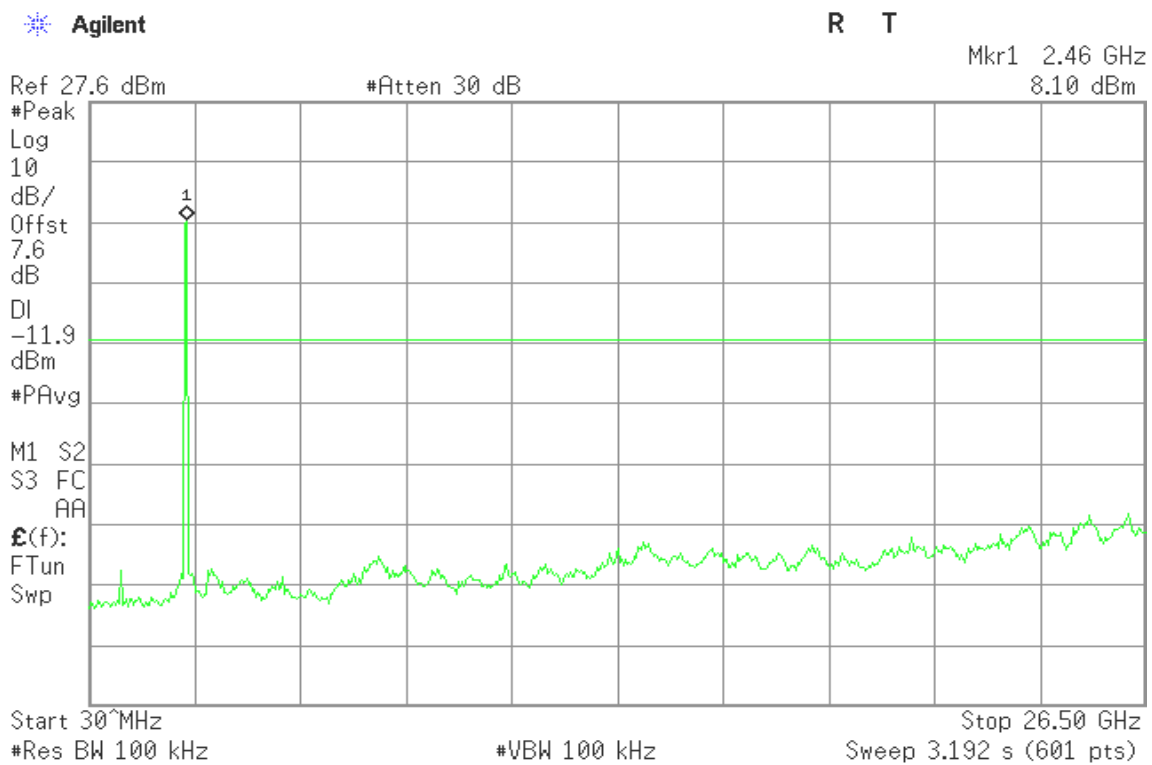



### CH High

Agilent

R T

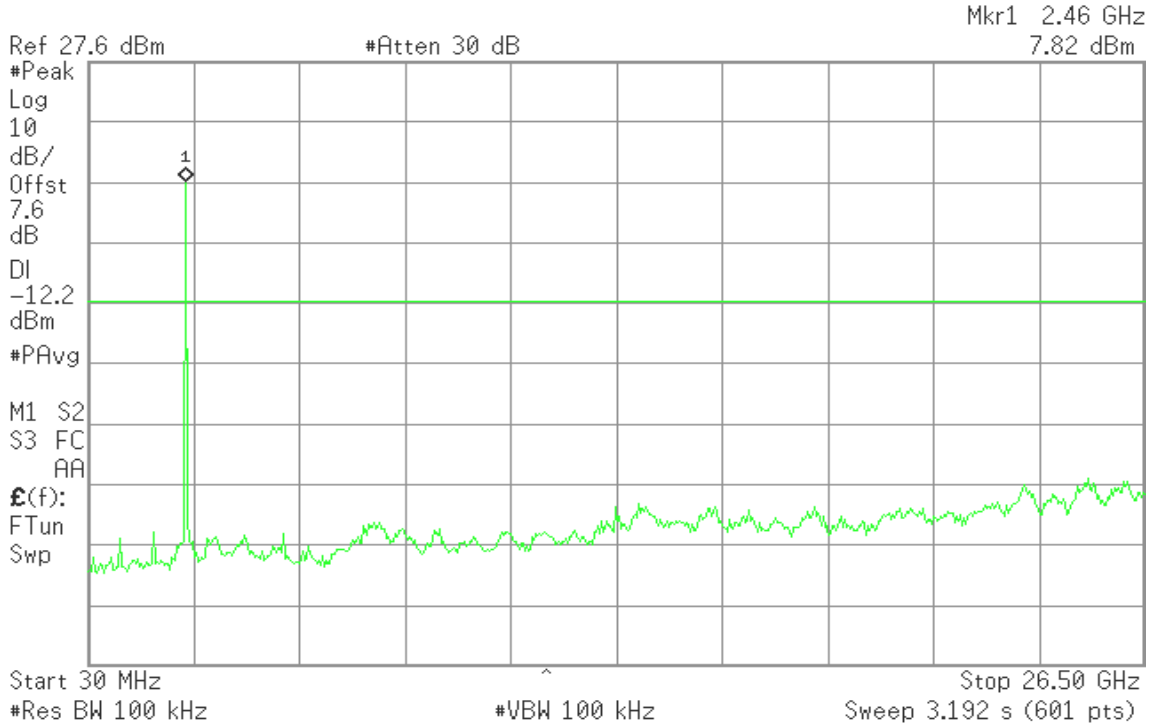

### IEEE 802.11g mode

#### CH Low

Agilent

R T

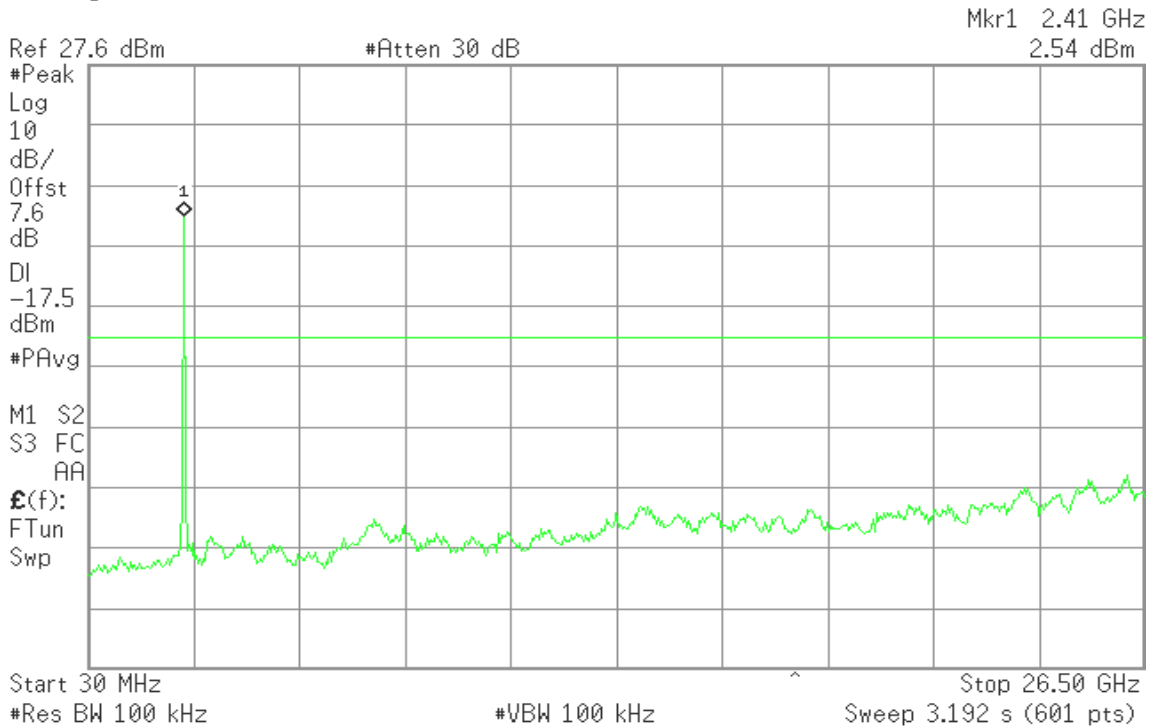



### CH Mid

Agilent

R T

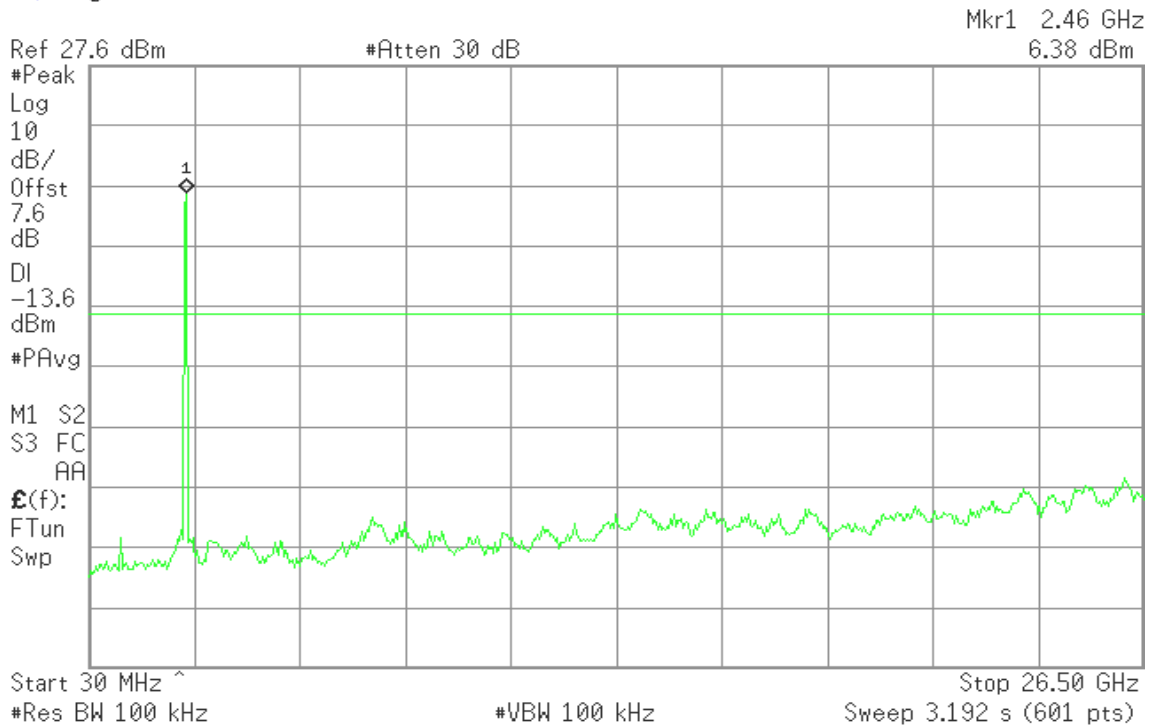

### CH High

Agilent

R T

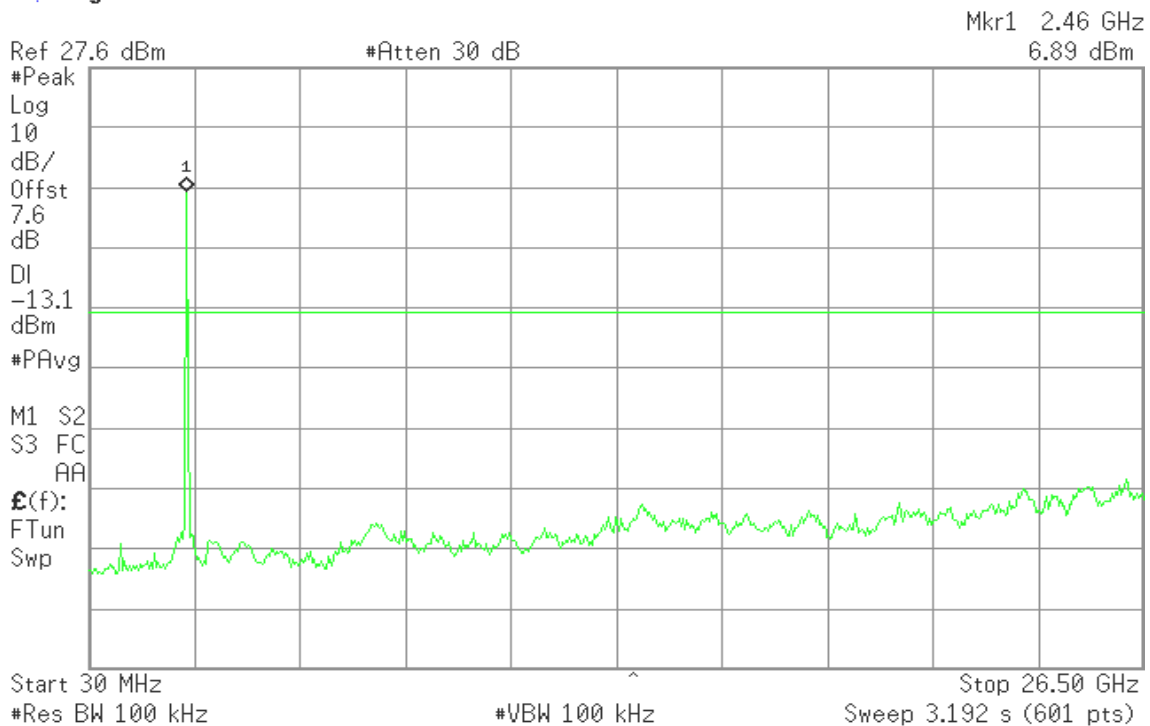



### IEEE 802.11n HT20 mode / Chain 0

#### CH Low

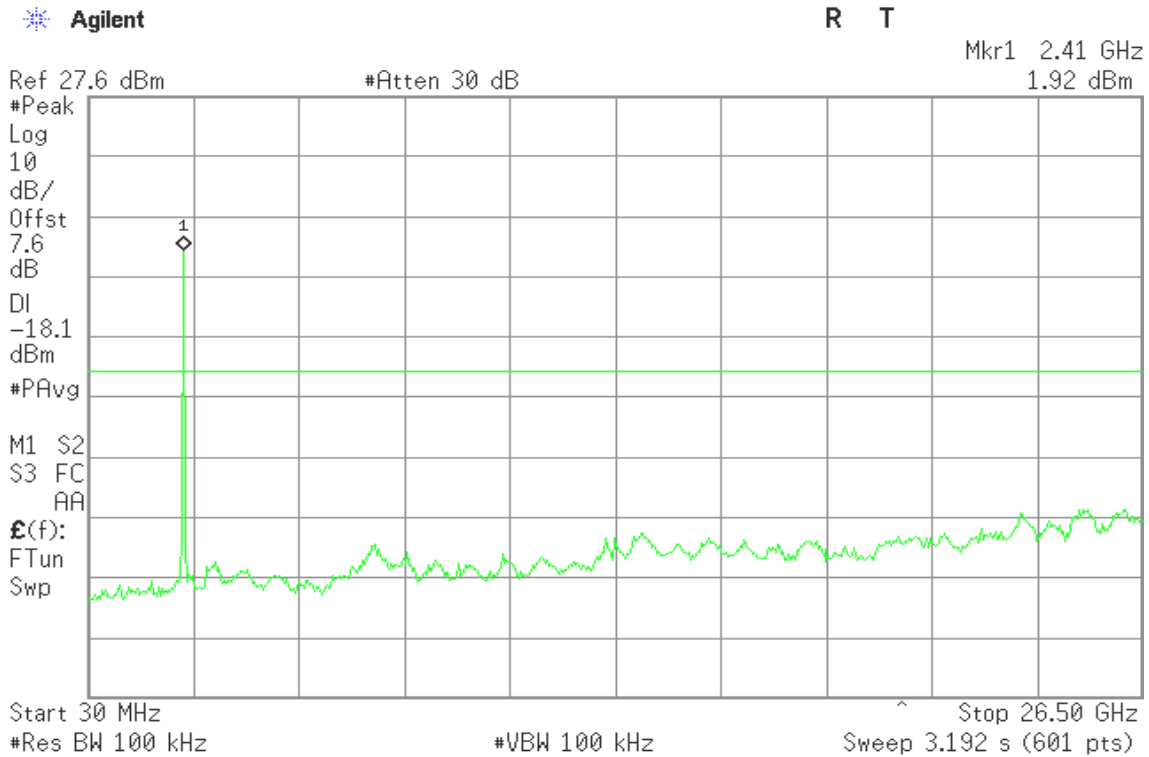

#### CH Mid

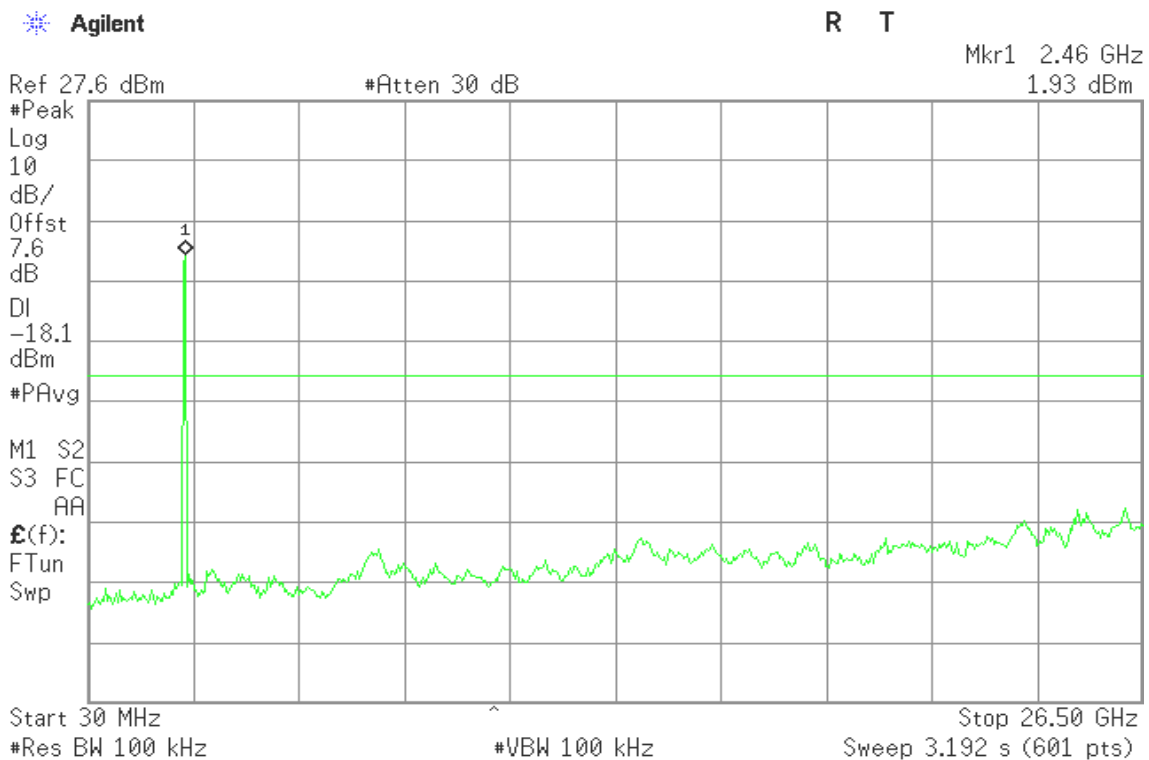



### CH High

Agilent

R T

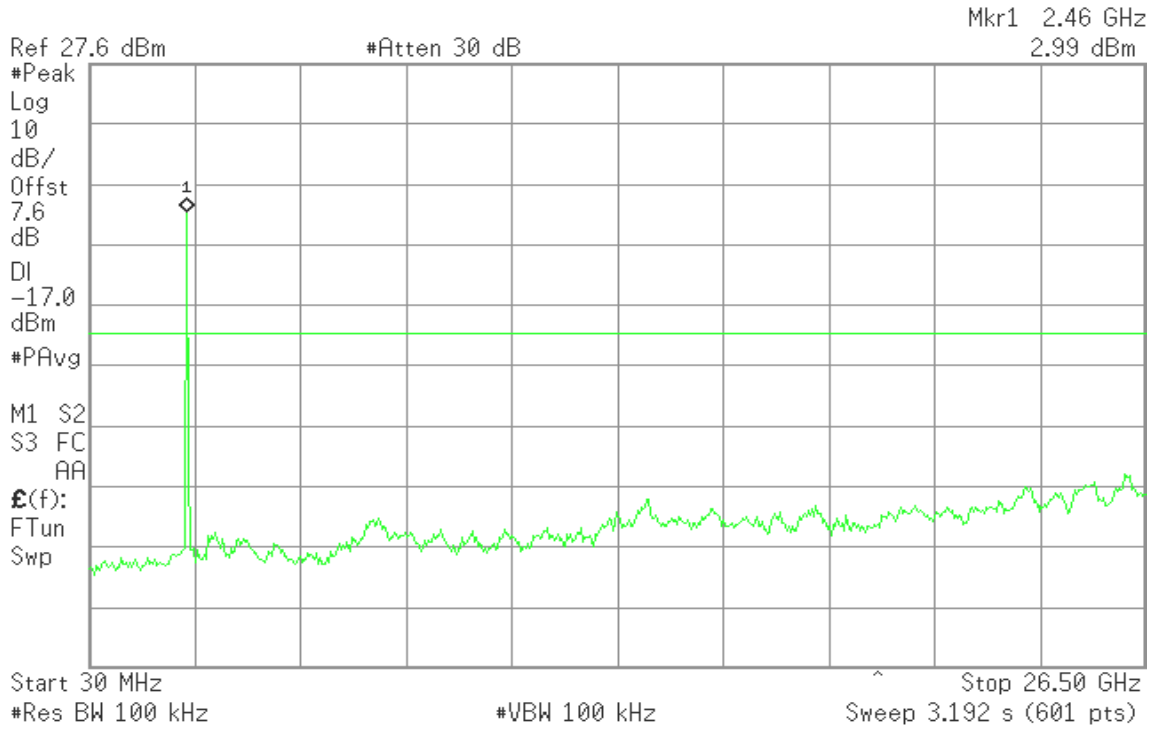

### IEEE 802.11n HT20 mode / Chain 1

#### CH Low

Agilent

R T

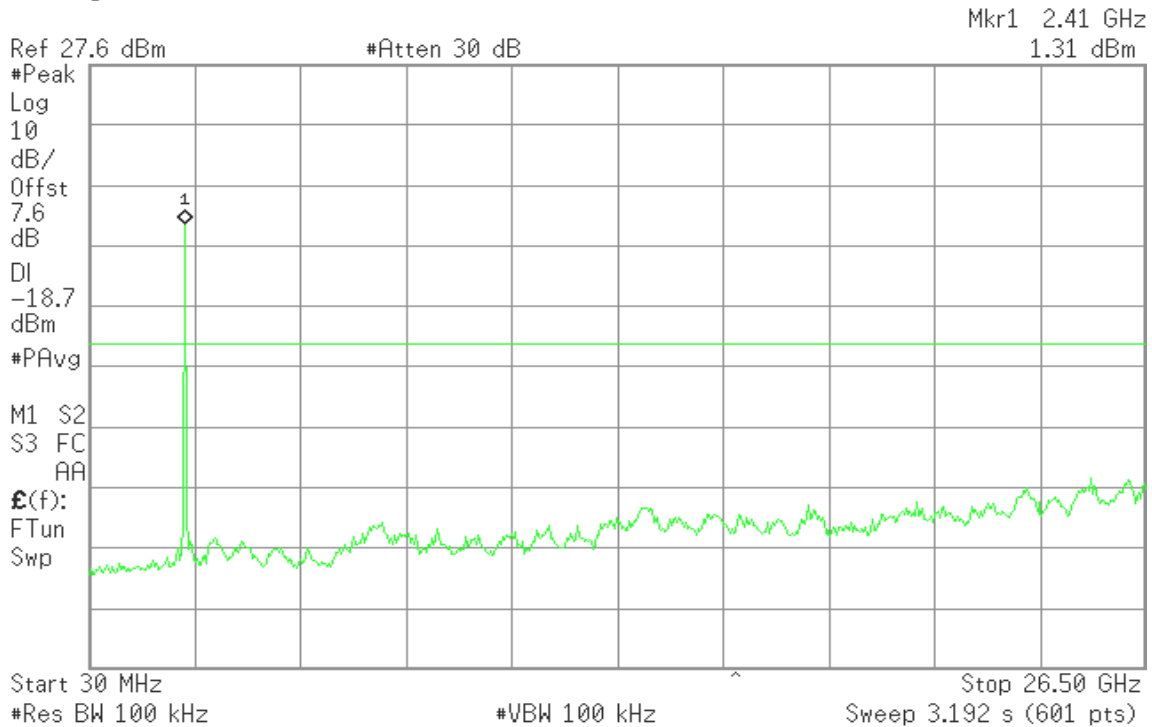



### CH Mid

Agilent

R T

Mkr1 2.46 GHz  
4.14 dBm

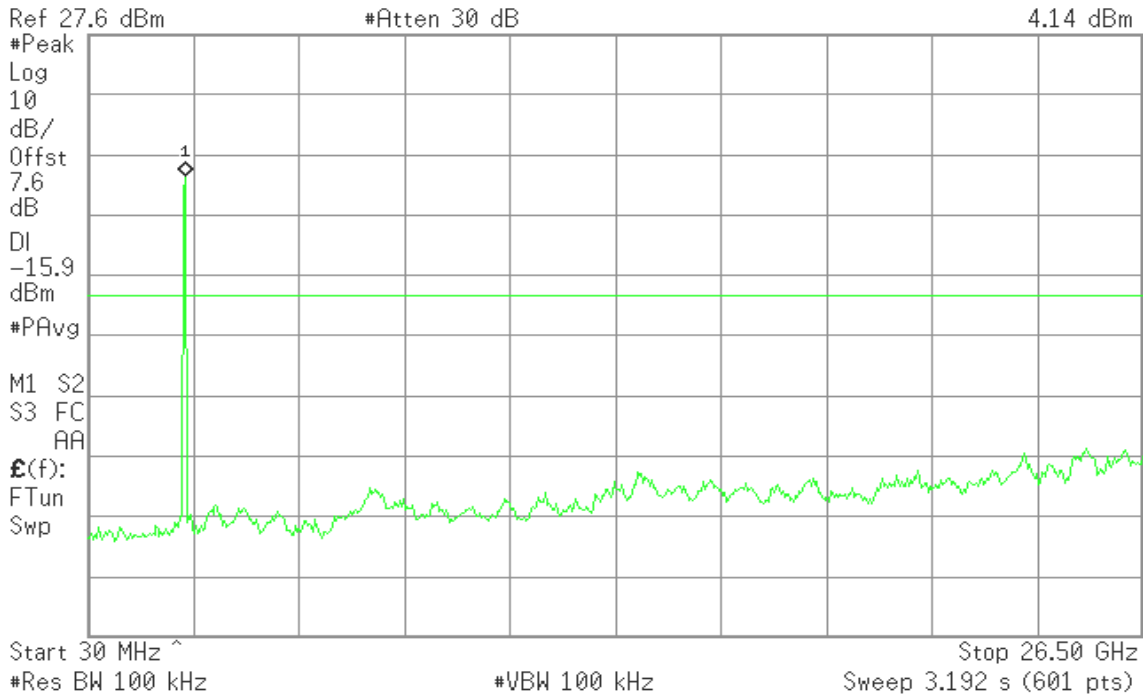

### CH High

Agilent

R T

Mkr1 2.46 GHz  
4.31 dBm

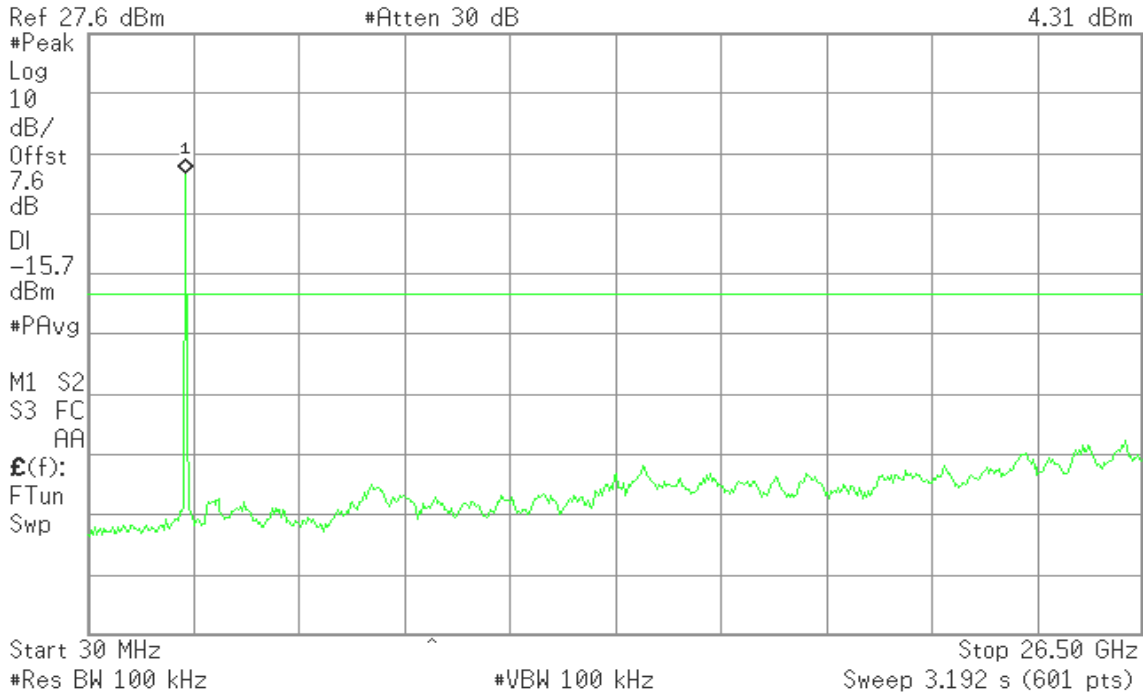



**IEEE 802.11n HT40 mode / Chain 0**

**CH Low**

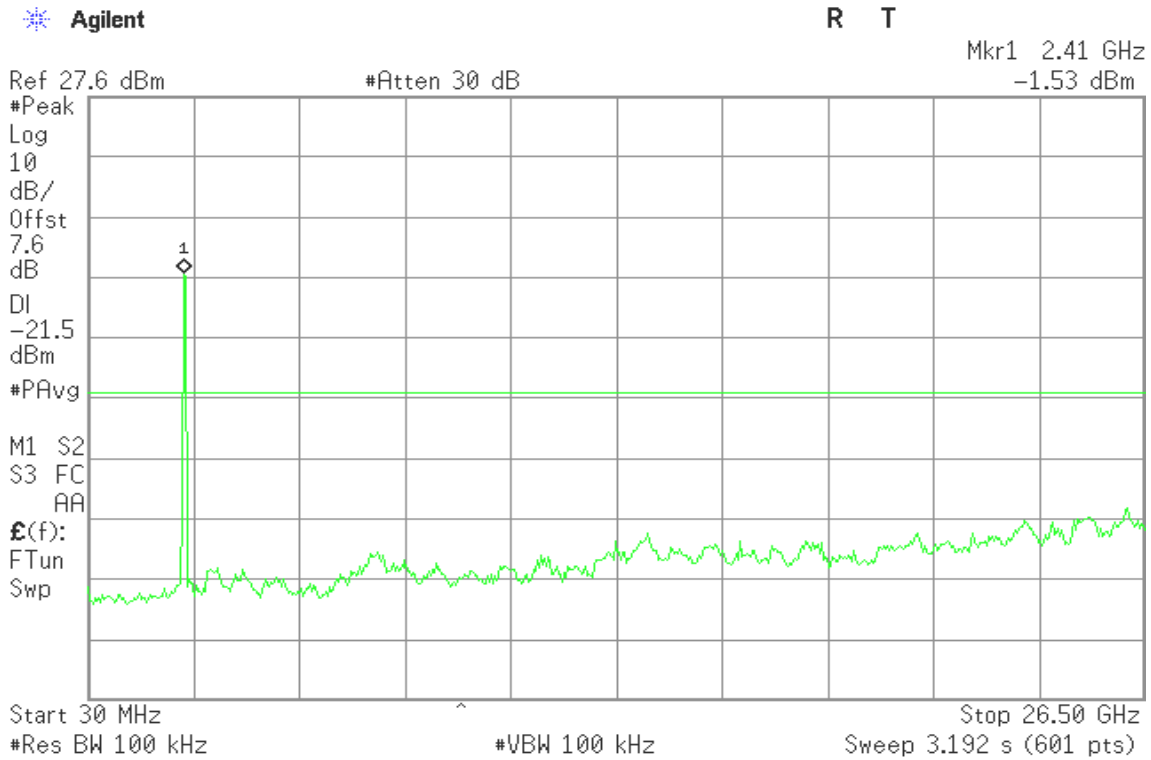

**CH Mid**

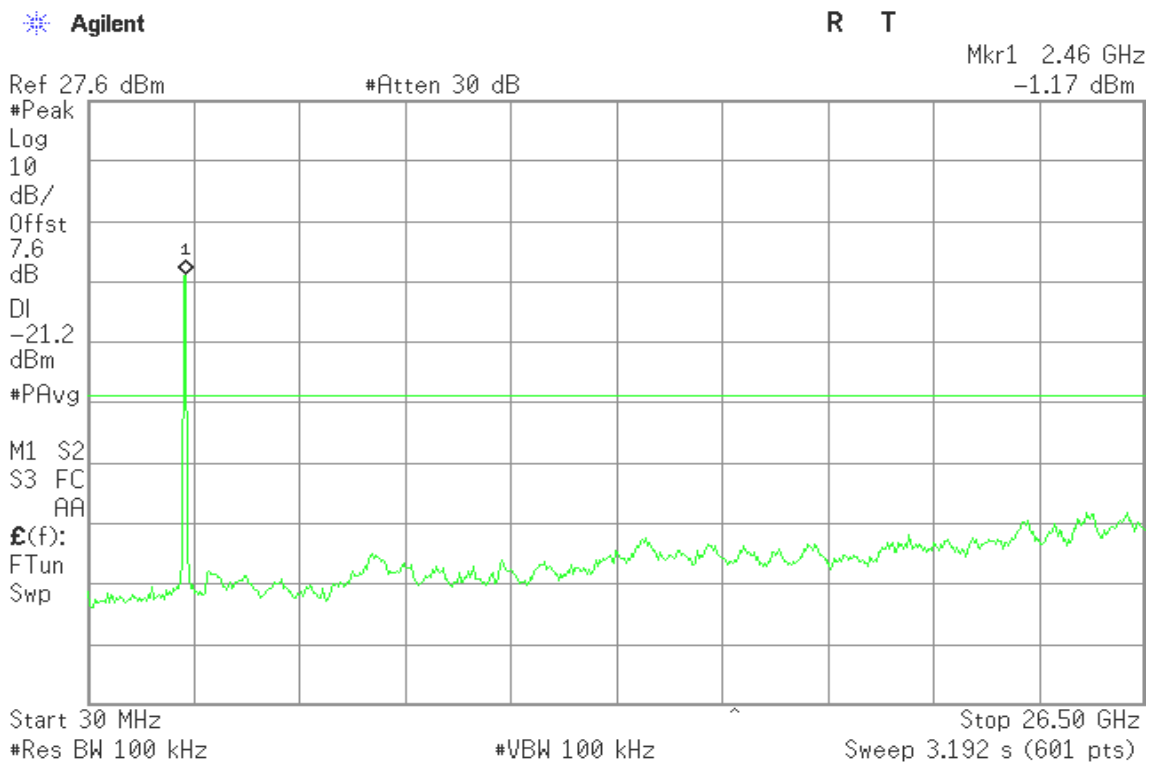





### CH High

Agilent

R T

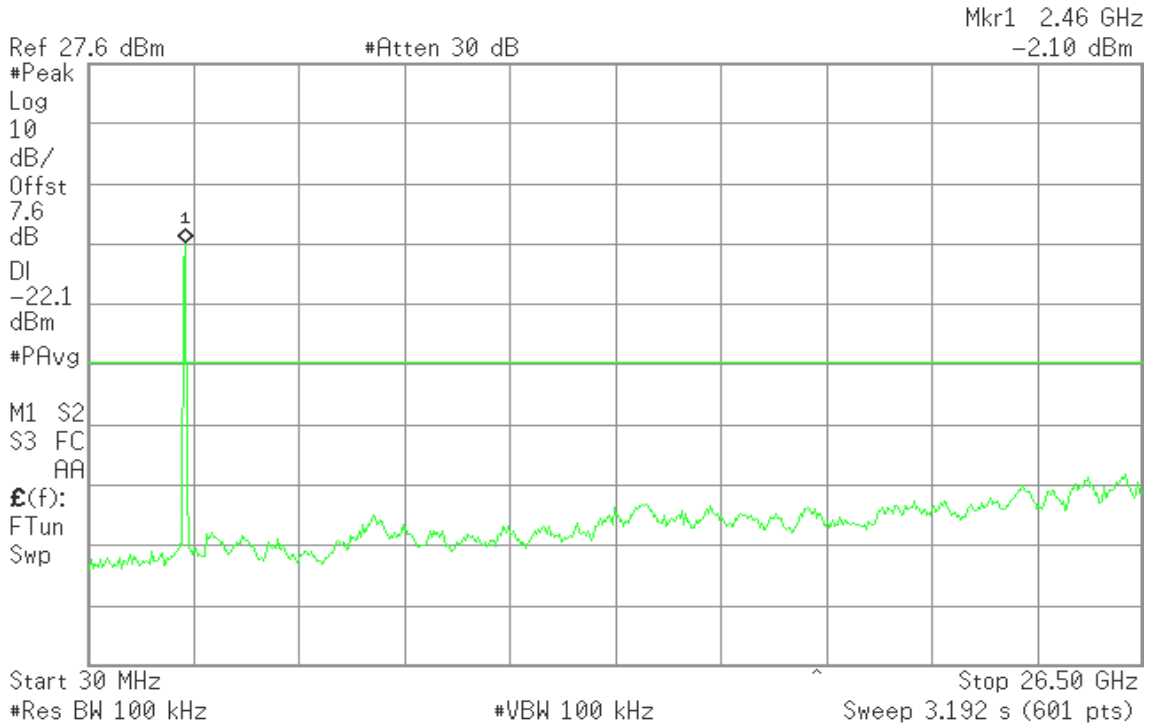

### IEEE 802.11n HT40 mode / Chain 1

#### CH Low

Agilent

R T

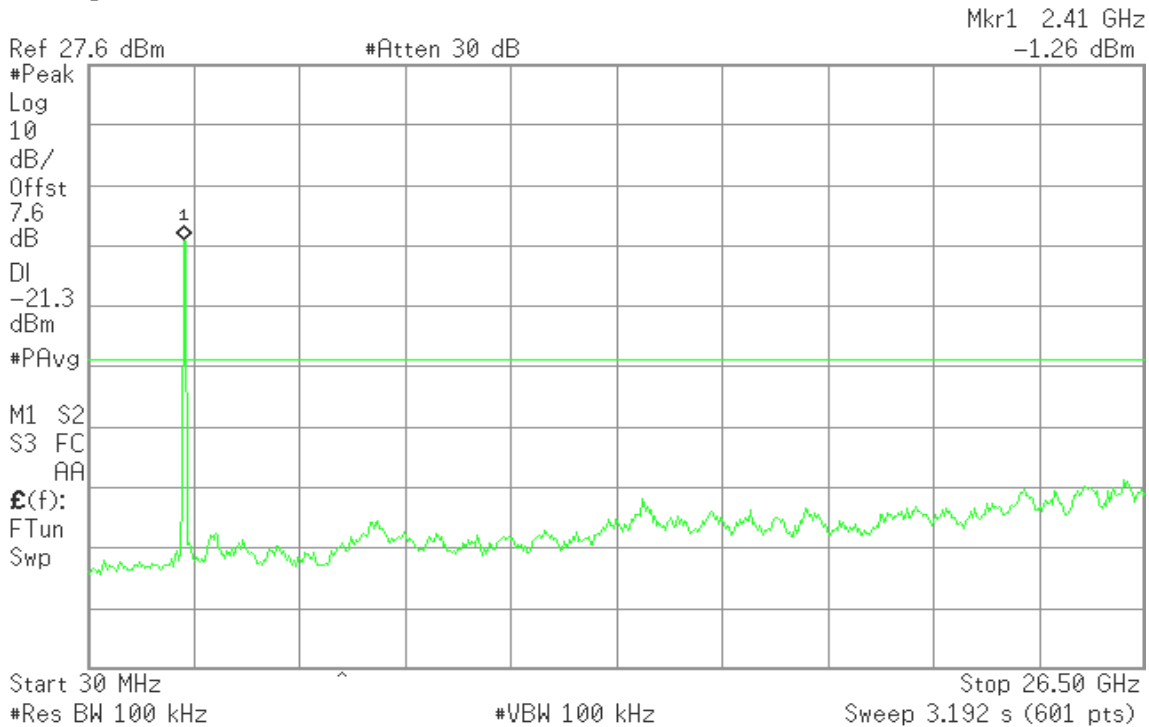



### CH Mid

Agilent

R T

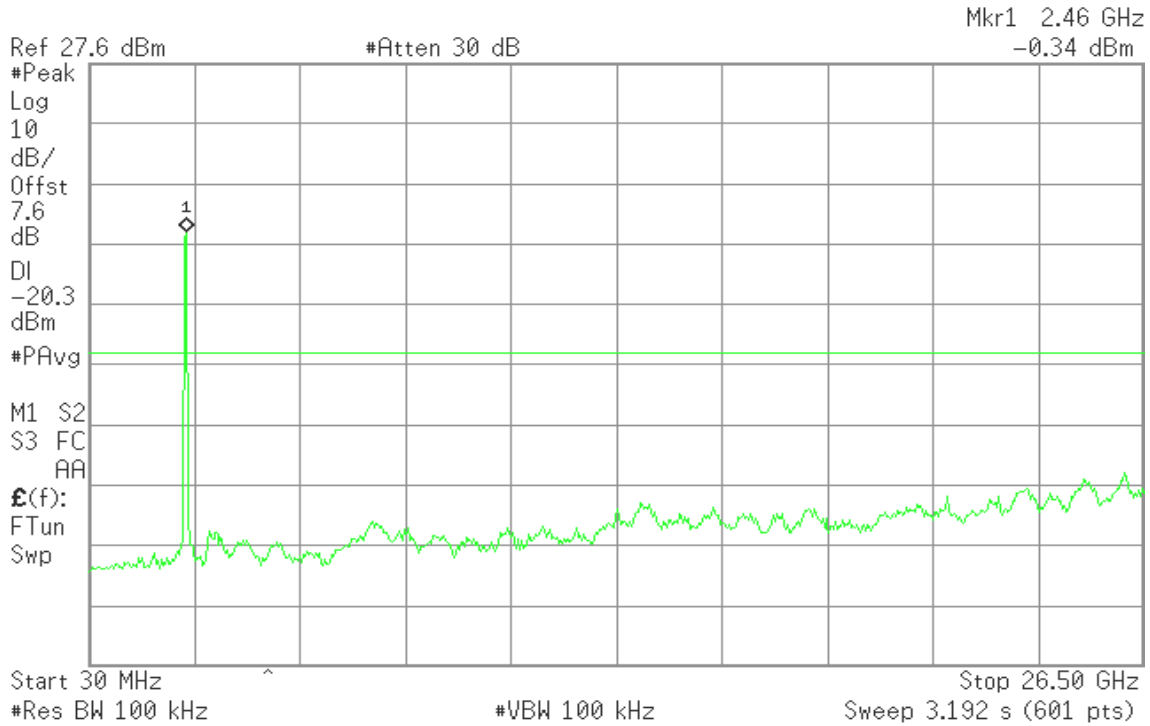

### CH High

Agilent

R T

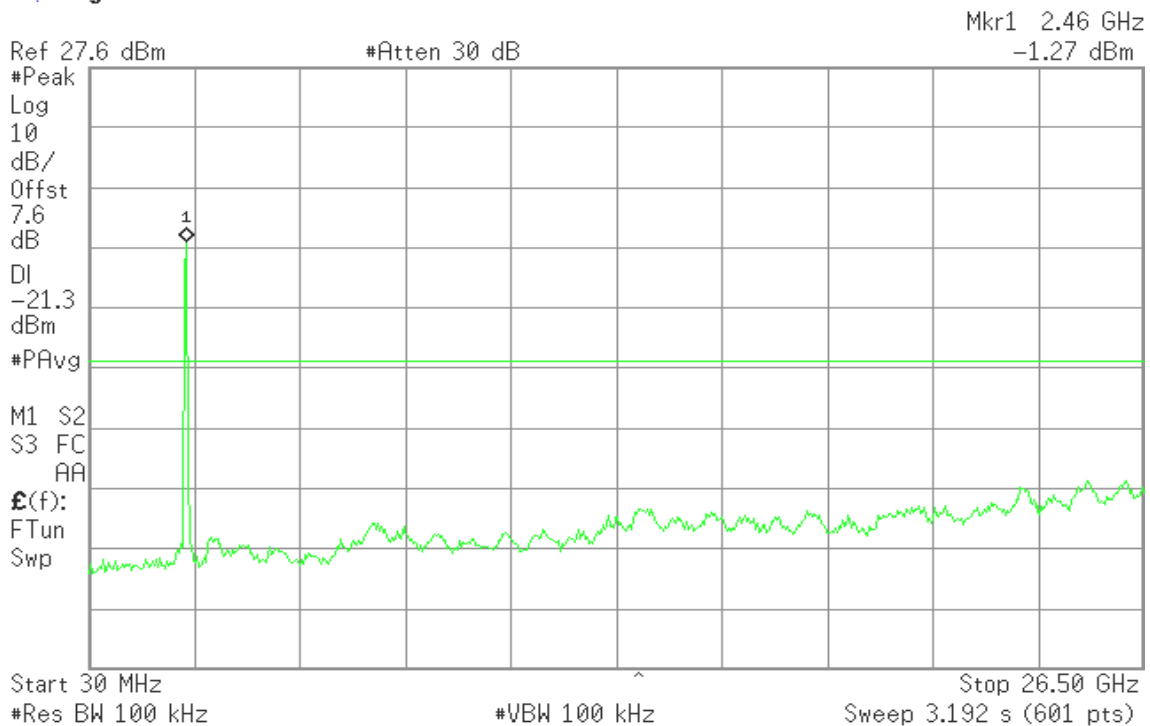



**Conducted band-edge**

**IEEE 802.11b mode**

**CH Low**

Agilent

R T

Mkr2 2.412 75 GHz  
5.68 dBm

Ref 27.6 dBm

#Atten 30 dB

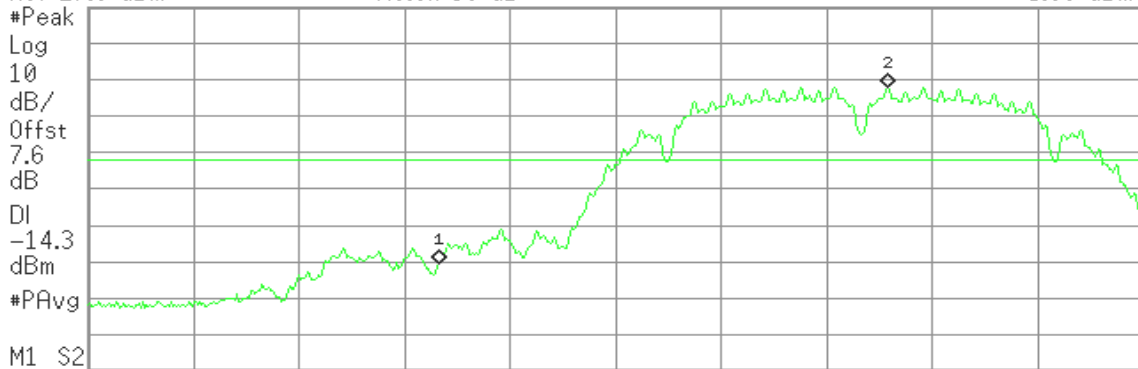

Start 2.390 00 GHz

Stop 2.420 00 GHz

#Res BW 100 kHz

#VBW 100 kHz

Sweep 23.56 ms (601 pts)

Marker	Trace	Type	X Axis	Amplitude
1	(1)	Freq	2.400 00 GHz	-42.81 dBm
2	(1)	Freq	2.412 75 GHz	5.68 dBm

**CH High**

Agilent

R T

Mkr1 2.462 73 GHz  
6.45 dBm

Ref 27.6 dBm

#Atten 30 dB

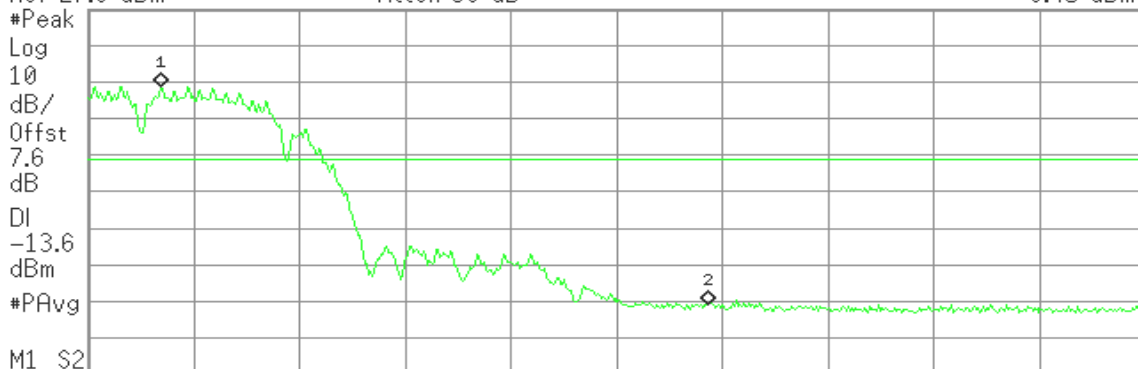

Start 2.460 00 GHz

Stop 2.500 00 GHz

#Res BW 100 kHz

#VBW 100 kHz

Sweep 31.44 ms (601 pts)

Marker	Trace	Type	X Axis	Amplitude
1	(1)	Freq	2.462 73 GHz	6.45 dBm
2	(1)	Freq	2.483 50 GHz	-53.37 dBm



**IEEE 802.11g mode**

**CH Low**

Agilent

R T

Mkr2 2.419 50 GHz  
0.27 dBm

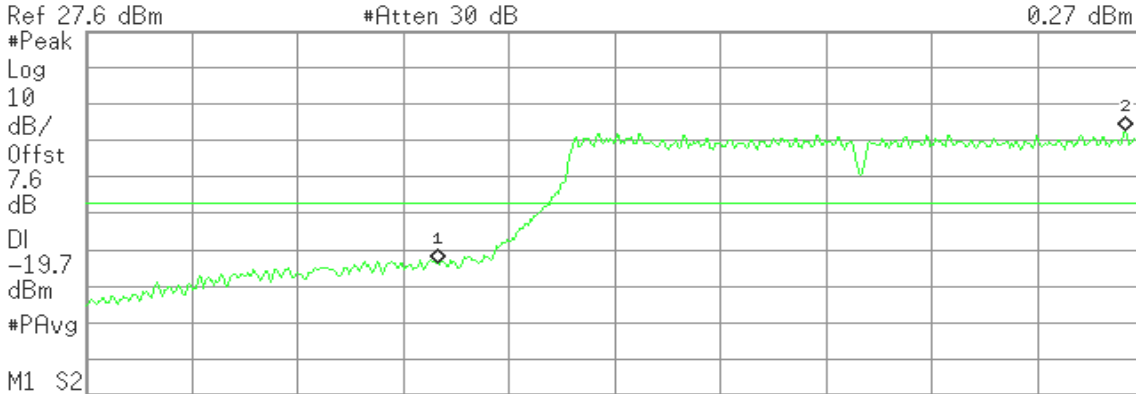

Start 2.390 00 GHz Stop 2.420 00 GHz  
 #Res BW 100 kHz #VBW 100 kHz Sweep 23.56 ms (601 pts)

Marker	Trace	Type	X Axis	Amplitude
1	(1)	Freq	2.400 00 GHz	-36.05 dBm
2	(1)	Freq	2.419 50 GHz	0.27 dBm

**CH High**

Agilent

R T

Mkr1 2.469 47 GHz  
3.17 dBm



Start 2.460 00 GHz Stop 2.500 00 GHz  
 #Res BW 100 kHz #VBW 100 kHz Sweep 31.44 ms (601 pts)

Marker	Trace	Type	X Axis	Amplitude
1	(1)	Freq	2.469 47 GHz	3.17 dBm
2	(1)	Freq	2.483 50 GHz	-40.01 dBm



IEEE 802.11n HT20 mode / Chain 0

CH Low

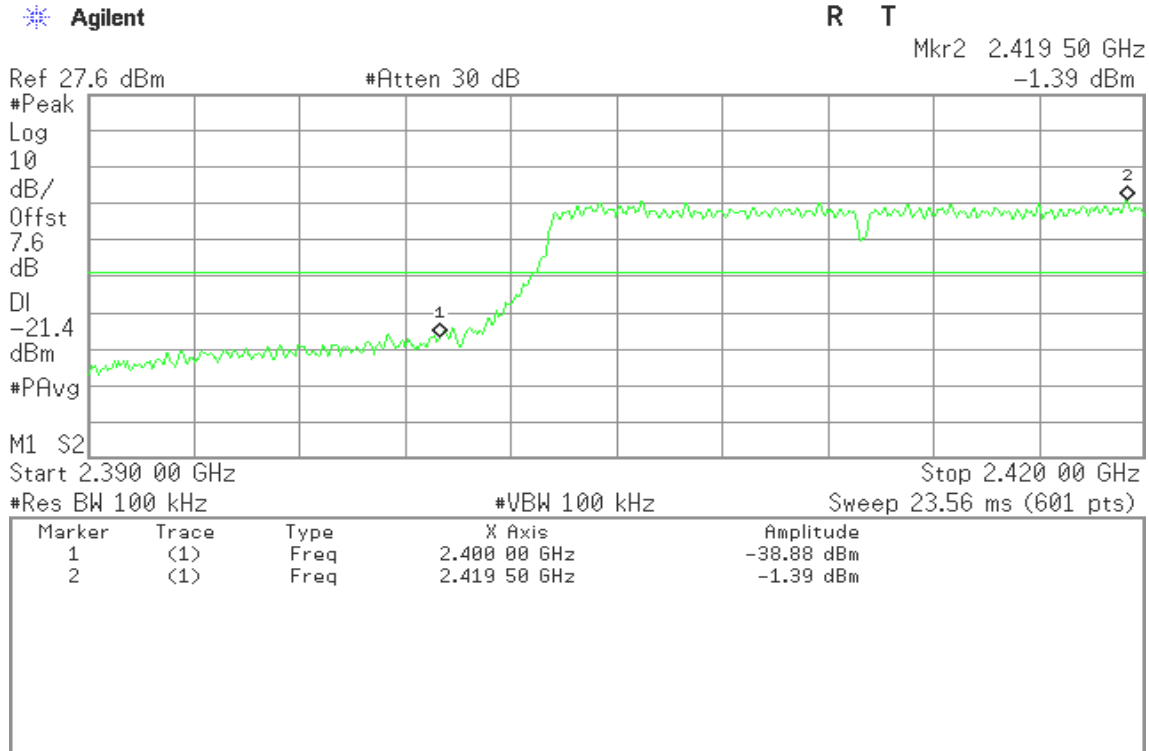

CH High

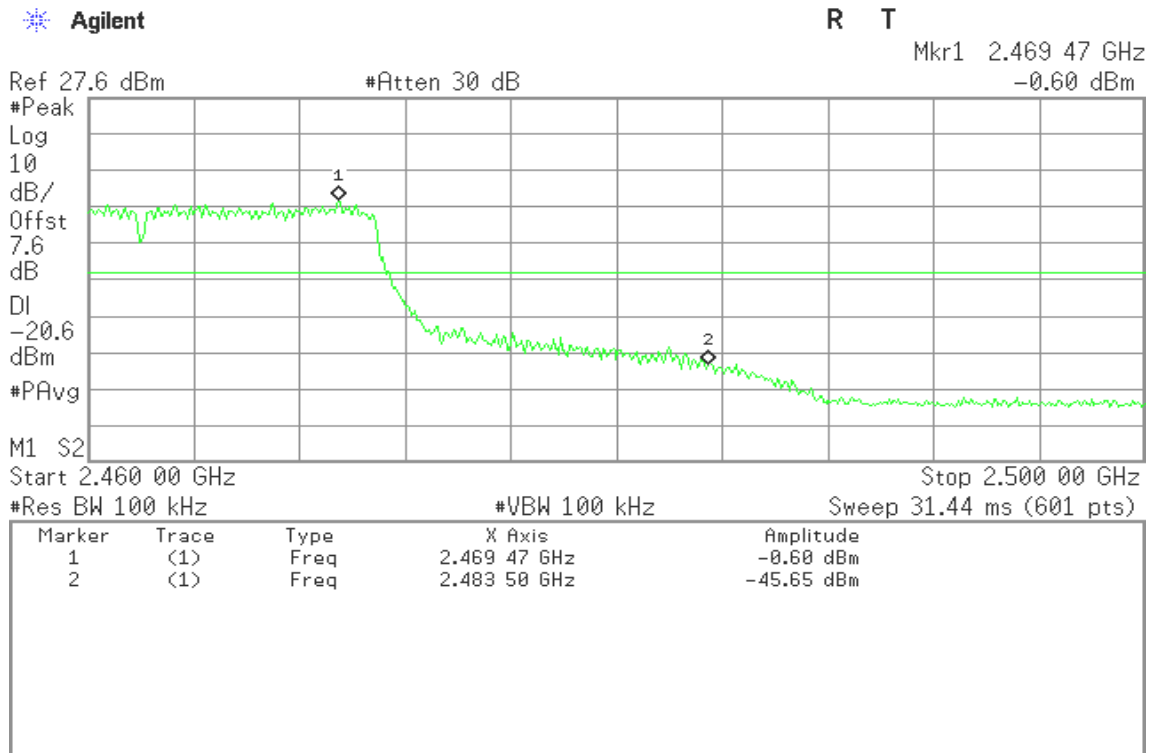



**IEEE 802.11n HT20 mode / Chain 1**

**CH Low**

Agilent

R T

Mkr2 2.419 50 GHz  
-1.05 dBm

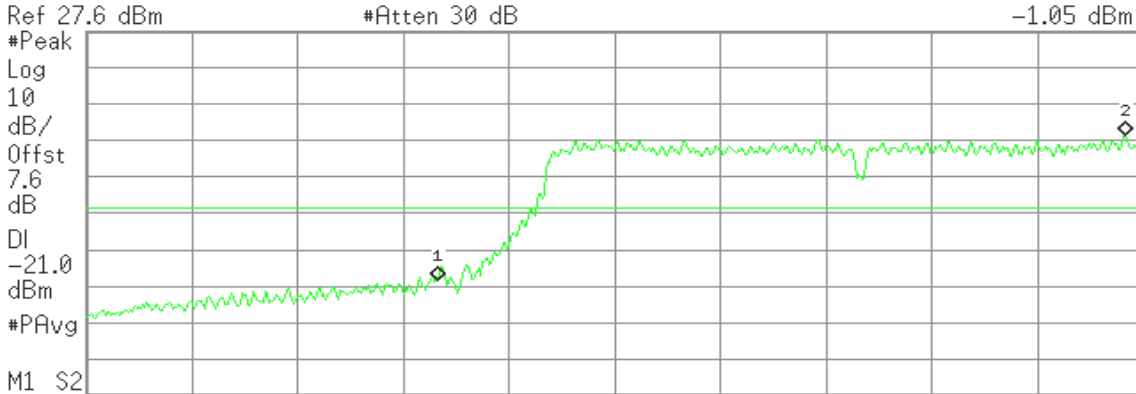

Start 2.390 00 GHz Stop 2.420 00 GHz  
#Res BW 100 kHz #VBW 100 kHz Sweep 23.56 ms (601 pts)

Marker	Trace	Type	X Axis	Amplitude
1	(1)	Freq	2.400 00 GHz	-41.00 dBm
2	(1)	Freq	2.419 50 GHz	-1.05 dBm

**CH High**

Agilent

R T

Mkr1 2.469 47 GHz  
0.71 dBm

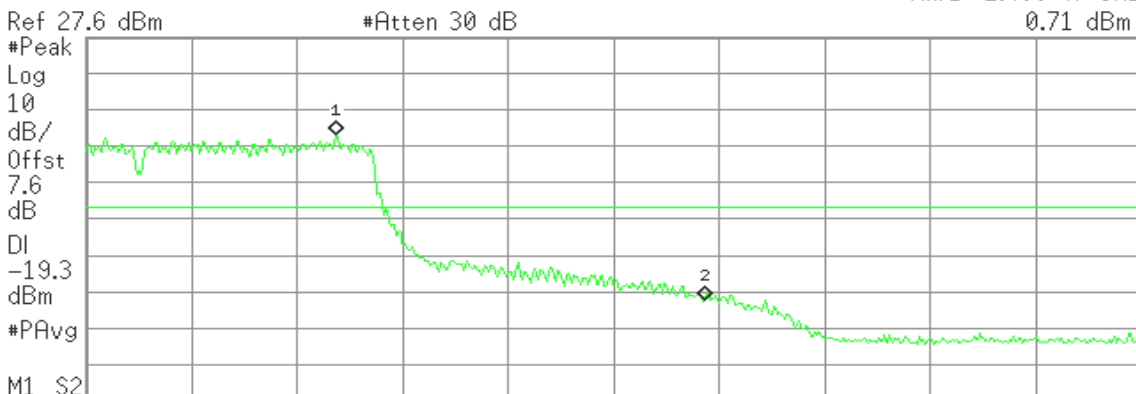

Start 2.460 00 GHz Stop 2.500 00 GHz  
#Res BW 100 kHz #VBW 100 kHz Sweep 31.44 ms (601 pts)

Marker	Trace	Type	X Axis	Amplitude
1	(1)	Freq	2.469 47 GHz	0.71 dBm
2	(1)	Freq	2.483 50 GHz	-44.56 dBm



IEEE 802.11n HT40 mode / Chain 0

CH Low

Agilent

R T

Mkr2 2.405 75 GHz  
-4.48 dBm

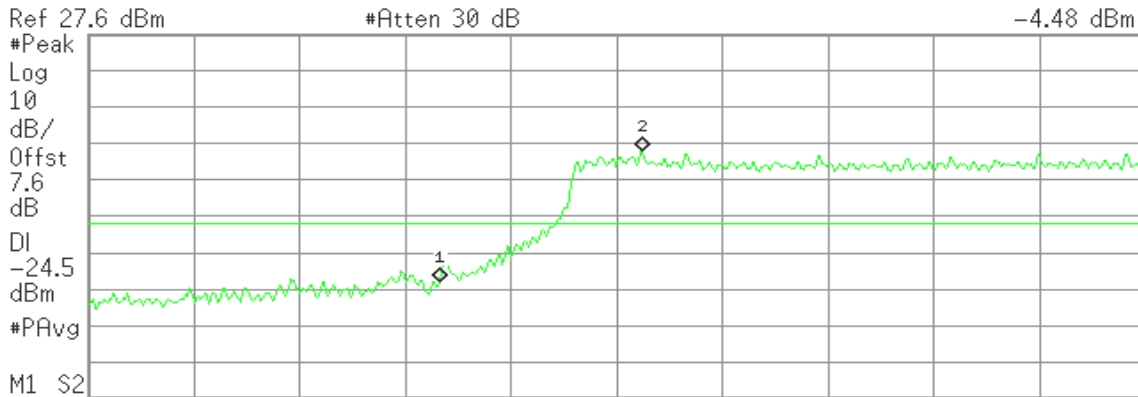

Start 2.390 00 GHz Stop 2.420 00 GHz  
#Res BW 100 kHz #VBW 100 kHz Sweep 23.56 ms (601 pts)

Marker	Trace	Type	X Axis	Amplitude
1	(1)	Freq	2.400 00 GHz	-40.54 dBm
2	(1)	Freq	2.405 75 GHz	-4.48 dBm

CH High

Agilent

R T

Mkr1 2.469 47 GHz  
-6.34 dBm

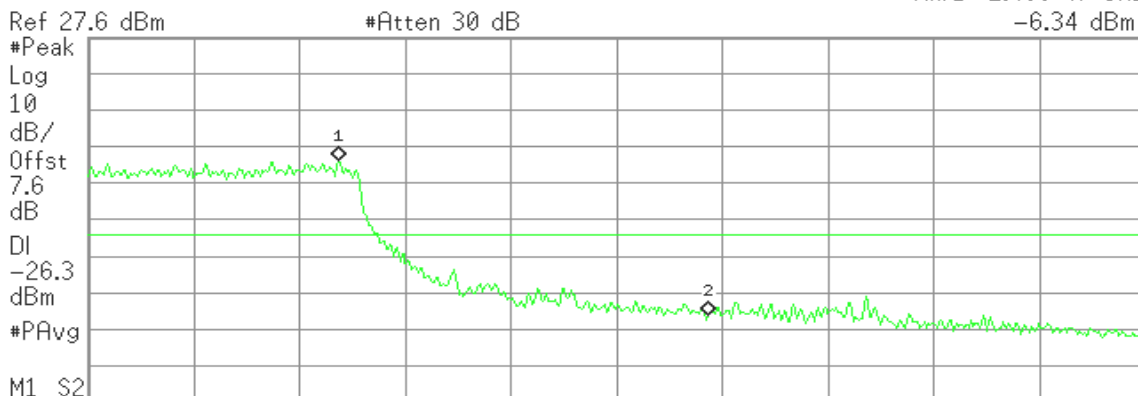

Start 2.460 00 GHz Stop 2.500 00 GHz  
#Res BW 100 kHz #VBW 100 kHz Sweep 31.44 ms (601 pts)

Marker	Trace	Type	X Axis	Amplitude
1	(1)	Freq	2.469 47 GHz	-6.34 dBm
2	(1)	Freq	2.483 50 GHz	-48.53 dBm



**IEEE 802.11n HT40 mode / Chain 1**

**CH Low**

Agilent

R T

Mkr2 2.417 00 GHz  
-5.11 dBm

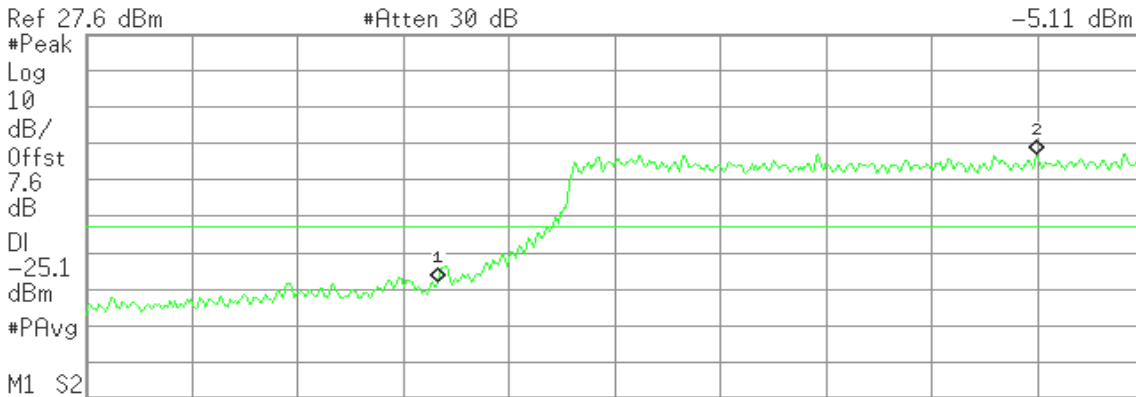

Start 2.390 00 GHz Stop 2.420 00 GHz  
#Res BW 100 kHz #VBW 100 kHz Sweep 23.56 ms (601 pts)

Marker	Trace	Type	X Axis	Amplitude
1	(1)	Freq	2.400 00 GHz	-40.26 dBm
2	(1)	Freq	2.417 00 GHz	-5.11 dBm

**CH High**

Agilent

R T

Mkr1 2.469 47 GHz  
-4.95 dBm



Start 2.460 00 GHz Stop 2.500 00 GHz  
#Res BW 100 kHz #VBW 100 kHz Sweep 31.44 ms (601 pts)

Marker	Trace	Type	X Axis	Amplitude
1	(1)	Freq	2.469 47 GHz	-4.95 dBm
2	(1)	Freq	2.483 50 GHz	-46.74 dBm





## 7.6.2 RADIATED EMISSIONS

### LIMIT

1. According to §15.209(a), except as provided elsewhere in this Subpart, the emissions from an intentional radiator shall not exceed the field strength levels specified in the following table:

Frequency (MHz)	Field Strength ( $\mu\text{V/m}$ )	Measurement Distance (m)
30-88	100*	3
88-216	150*	3
216-960	200*	3
Above 960	500	3

**Remark:** Except as provided in paragraph (g), fundamental emissions from intentional radiators operating under this Section shall not be located in the frequency bands 54-72 MHz, 76-88 MHz, 174-216 MHz or 470-806 MHz. However, operation within these frequency bands is permitted under other sections of this Part, e.g., Sections 15.231 and 15.241.

2. In the emission table above, the tighter limit applies at the band edges.

Frequency (MHz)	Field Strength ( $\mu\text{V/m}$ at 3-meter)	Field Strength (dB $\mu\text{V/m}$ at 3-meter)
30-88	100	40
88-216	150	43.5
216-960	200	46
Above 960	500	54



## TEST CONFIGURATION

### 9kHz ~ 30MHz

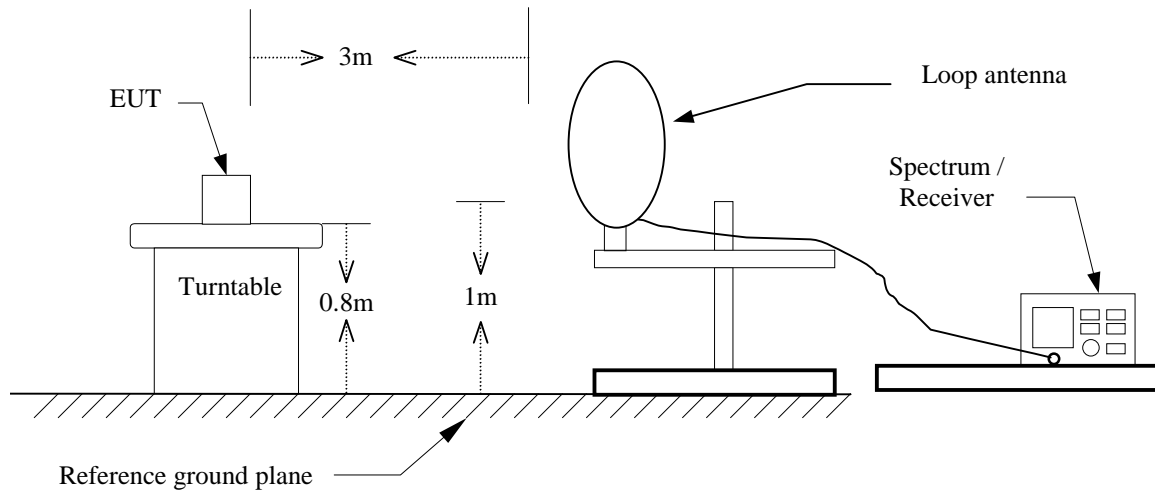

### 30MHz ~ 1GHz

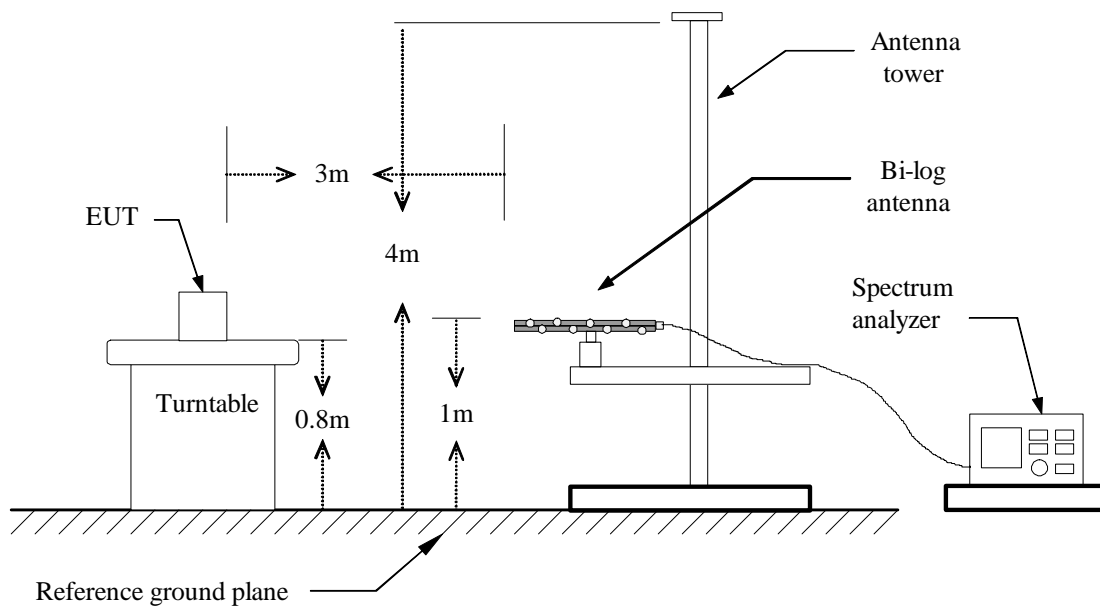



## Above 1 GHz

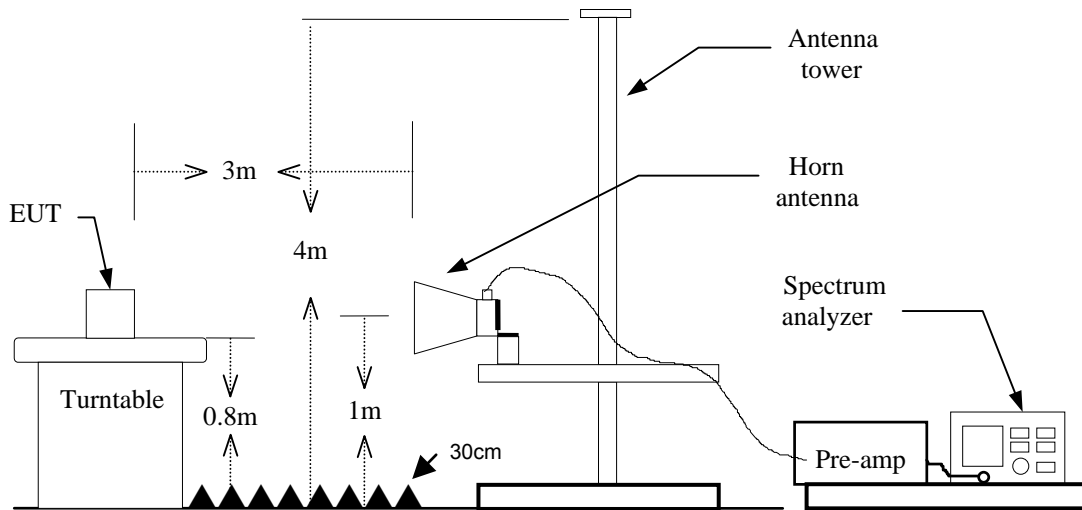

## TEST PROCEDURE

1. The EUT is placed on a turntable, which is 0.8m above ground plane.
2. The turntable shall be rotated for 360 degrees to determine the position of maximum emission level.
3. EUT is set 3m away from the receiving antenna, which is varied from 1m to 4m to find out the highest emissions.
4. Maximum procedure was performed on the six highest emissions to ensure EUT compliance.
5. And also, each emission was to be maximized by changing the polarization of receiving antenna both horizontal and vertical.
6. Set the spectrum analyzer in the following setting as:

### **Below 30MHz**

RBW=10kHz / VBW=30kHz / Sweep=AUTO

### **30 ~ 1000MHz:**

RBW=100kHz / VBW=300KHz / Sweep=AUTO

### **Above 1GHz:**

- a) PEAK: RBW=VBW=1MHz / Sweep=AUTO
- b) AVERAGE: RBW=1MHz / VBW=10Hz / Sweep=AUTO

7. Repeat above procedures until the measurements for all frequencies are complete.

## TEST RESULTS

*No non-compliance noted.*



## TEST DATA

### Below 1GHz

Operation Mode: Transmitting                      Test Date: 2013/10/21  
Temperature: 26°C                                      Tested by: Francis.lee  
Humidity: 56% RH                                      Polarity: Ver. / Hor.

Frequency (MHz)	Reading (dBuV)	Correction Factor (dB/m)	Result (dBuV/m)	Limit (dBuV/m)	Margin (dB)	Ant. Pol. (H/V)	Remark
69.7700	51.15	-21.01	30.14	40.00	-9.86	V	QP
185.2000	42.61	-17.23	25.38	43.50	-18.12	V	QP
335.5500	34.91	-11.22	23.69	46.00	-22.31	V	QP
450.0100	46.68	-9.58	37.10	46.00	-8.90	V	QP
672.1400	42.17	-6.88	35.29	46.00	-10.71	V	QP
900.0900	31.68	-3.44	28.24	46.00	-17.76	V	QP
73.6500	46.81	-20.62	26.19	40.00	-13.81	H	QP
185.2000	42.19	-17.23	24.96	43.50	-18.54	H	QP
450.0100	43.91	-9.58	34.33	46.00	-11.67	H	QP
550.8900	31.28	-8.24	23.04	46.00	-22.96	H	QP
672.1400	40.62	-6.88	33.74	46.00	-12.26	H	QP
900.0900	30.31	-3.44	26.87	46.00	-19.13	H	QP

**Remark:**

1. No emission found between lowest internal used / generated frequency to 30 MHz. (9kHz ~ 30MHz)
2. Measuring frequencies from 9 kHz to the 1GHz.
3. Radiated emissions measured in the measured frequency range were made with an instrument using peak detector or quasi-peak detector mode.
4. Data of measurement within this frequency range shown " --- " in the table above means the reading of emissions are attenuated more than 20dB below the permissible limits or the field strength is too small to be measured.
5. The IF bandwidth of SPA between 30MHz to 1GHz was 100kHz.



**Above 1 GHz**

**Operation Mode:** TX / IEEE 802.11b / CH Low **Test Date:** 2013/10/3

**Temperature:** 26°C **Tested by:** Francis Lee

**Humidity:** 56 % RH **Polarity:** Ver. / Hor.

Freq. (MHz)	Reading (dBuV)	Correct Factor (dB/m)	Result (dBuV/m)	Limit (dBuV/m)	Margin (dB)	Ant. Pol H/V	Remark
1584.000	54.30	-4.87	49.43	74.00	-24.57	V	peak
1996.000	51.78	-1.36	50.42	74.00	-23.58	V	peak
2644.000	54.49	-1.86	52.63	74.00	-21.37	V	peak
2644.000	40.84	-1.86	38.98	54.00	-15.02	V	AVG
3795.000	36.72	3.63	40.35	74.00	-33.65	V	peak
4825.000	50.27	2.68	52.95	74.00	-21.05	V	peak
4825.000	49.32	2.68	52.00	54.00	-2.00	V	AVG
7235.000	37.40	10.21	47.61	74.00	-26.39	V	peak
1344.000	60.95	-8.34	52.61	74.00	-21.39	H	peak
1344.000	54.10	-8.34	45.76	54.00	-8.24	H	AVG
1680.000	57.87	-8.01	49.86	74.00	-24.14	H	peak
2152.000	51.96	-3.67	48.29	74.00	-25.71	H	peak
2674.000	51.15	-3.37	47.78	74.00	-26.22	H	peak
4075.000	38.07	5.29	43.36	74.00	-30.64	H	peak
4825.000	44.96	5.88	50.84	74.00	-23.16	H	peak
7235.000	40.66	10.96	51.62	74.00	-22.38	H	peak

**Remark:**

1. Measuring frequencies from 1 GHz to the 10th harmonic of highest fundamental frequency.
2. Radiated emissions measured in frequency above 1000MHz were made with an instrument using peak/average detector mode.
3. Average test would be performed if the peak result were greater than the average limit or as required by the applicant.
4. Data of measurement within this frequency range shown " --- " in the table above means the reading of emissions are attenuated more than 20dB below the permissible limits or the field strength is too small to be measured.
5. Measurements above show only up to 6 maximum emissions noted, or would be lesser, with " N/A " remark, if no specific emissions from the EUT are recorded (ie: margin>20dB from the applicable limit) and considered that's already beyond the background noise floor.



**Operation Mode:** TX / IEEE 802.11b / CH Mid

**Test Date:** 2013/10/3

**Temperature:** 26°C

**Tested by:** Francis Lee

**Humidity:** 56 % RH

**Polarity:** Ver. / Hor.

Freq. (MHz)	Reading (dBuV)	Correct Factor (dB/m)	Result (dBuV/m)	Limit (dBuV/m)	Margin (dB)	Ant. Pol H/V	Remark
1474.000	53.17	-5.62	47.55	74.00	-26.45	V	peak
1950.000	52.39	-2.09	50.30	74.00	-23.70	V	peak
2708.000	55.17	-1.52	53.65	74.00	-20.35	V	peak
2708.000	38.83	-1.52	37.31	54.00	-16.69	V	AVG
3810.000	35.60	3.47	39.07	74.00	-34.93	V	peak
4875.000	50.96	3.81	54.77	74.00	-19.23	V	peak
4875.000	49.18	3.81	52.99	54.00	-1.01	V	AVG
7310.000	38.87	10.56	49.43	74.00	-24.57	V	peak
1344.000	61.64	-8.34	53.30	74.00	-20.70	H	peak
1344.000	54.84	-8.34	46.50	54.00	-7.50	H	AVG
1680.000	57.92	-8.01	49.91	74.00	-24.09	H	peak
2794.000	51.96	-2.53	49.43	74.00	-24.57	H	peak
3870.000	36.61	5.18	41.79	74.00	-32.21	H	peak
4875.000	47.57	6.73	54.30	74.00	-19.70	H	peak
4875.000	45.84	6.73	52.57	54.00	-1.43	H	AVG
7310.000	40.62	11.77	52.39	74.00	-21.61	H	peak
7310.000	33.01	11.77	44.78	54.00	-9.22	H	AVG

**Remark:**

1. Measuring frequencies from 1 GHz to the 10th harmonic of highest fundamental frequency.
2. Radiated emissions measured in frequency above 1000MHz were made with an instrument using peak/average detector mode.
3. Average test would be performed if the peak result were greater than the average limit or as required by the applicant.
4. Data of measurement within this frequency range shown " --- " in the table above means the reading of emissions are attenuated more than 20dB below the permissible limits or the field strength is too small to be measured.
5. Measurements above show only up to 6 maximum emissions noted, or would be lesser, with " N/A " remark, if no specific emissions from the EUT are recorded (ie: margin>20dB from the applicable limit) and considered that's already beyond the background noise floor.



Operation Mode: TX / IEEE 802.11b / CH High

Test Date: 2013/10/3

Temperature: 26°C

Tested by: Francis Lee

Humidity: 56 % RH

Polarity: Ver. / Hor.

Freq. (MHz)	Reading (dBuV)	Correct Factor (dB/m)	Result (dBuV/m)	Limit (dBuV/m)	Margin (dB)	Ant. Pol H/V	Remark
1548.000	52.81	-5.03	47.78	74.00	-26.22	V	peak
1994.000	51.43	-1.39	50.04	74.00	-23.96	V	peak
2706.000	53.64	-1.51	52.13	74.00	-21.87	V	peak
2706.000	38.26	-1.51	36.75	54.00	-17.25	V	AVG
3675.000	36.60	2.58	39.18	74.00	-34.82	V	peak
4925.000	50.75	4.61	55.36	74.00	-18.64	V	peak
4925.000	48.54	4.61	53.15	54.00	-0.85	V	AVG
7385.000	38.84	11.18	50.02	74.00	-23.98	V	peak
1344.000	60.55	-8.34	52.21	74.00	-21.79	H	peak
1344.000	55.54	-8.34	47.20	54.00	-6.80	H	AVG
1676.000	61.04	-8.09	52.95	74.00	-21.05	H	peak
1676.000	49.72	-8.09	41.63	54.00	-12.37	H	AVG
2636.000	52.07	-3.36	48.71	74.00	-25.29	H	peak
4310.000	34.61	7.59	42.20	74.00	-31.80	H	peak
4925.000	44.32	7.26	51.58	74.00	-22.42	H	peak
7390.000	36.76	11.36	48.12	74.00	-25.88	H	peak

Remark:

1. Measuring frequencies from 1 GHz to the 10th harmonic of highest fundamental frequency.
2. Radiated emissions measured in frequency above 1000MHz were made with an instrument using peak/average detector mode.
3. Average test would be performed if the peak result were greater than the average limit or as required by the applicant.
4. Data of measurement within this frequency range shown " --- " in the table above means the reading of emissions are attenuated more than 20dB below the permissible limits or the field strength is too small to be measured.
5. Measurements above show only up to 6 maximum emissions noted, or would be lesser, with " N/A " remark, if no specific emissions from the EUT are recorded (ie: margin>20dB from the applicable limit) and considered that's already beyond the background noise floor.



**Operation Mode:** TX / IEEE 802.11g / CH Low

**Test Date:** 2013/10/4

**Temperature:** 26°C

**Tested by:** Francis Lee

**Humidity:** 56 % RH

**Polarity:** Ver. / Hor.

Freq. (MHz)	Reading (dBuV)	Correct Factor (dB/m)	Result (dBuV/m)	Limit (dBuV/m)	Margin (dB)	Ant. Pol H/V	Remark
1344.000	53.99	-7.74	46.25	74.00	-27.75	V	peak
2004.000	52.16	-1.39	50.77	74.00	-23.23	V	peak
2654.000	53.79	-1.79	52.00	74.00	-22.00	V	peak
3800.000	35.76	3.69	39.45	74.00	-34.55	V	peak
4825.000	43.35	2.68	46.03	74.00	-27.97	V	peak
7595.000	34.58	11.89	46.47	74.00	-27.53	V	peak
1344.000	61.41	-8.34	53.07	74.00	-20.93	H	peak
1344.000	56.04	-8.34	47.70	54.00	-6.30	H	AVG
1680.000	57.64	-8.01	49.63	74.00	-24.37	H	peak
2124.000	52.10	-3.73	48.37	74.00	-25.63	H	peak
2850.000	51.21	-2.10	49.11	74.00	-24.89	H	peak
3795.000	36.60	5.03	41.63	74.00	-32.37	H	peak
4825.000	37.92	5.88	43.80	74.00	-30.20	H	peak
7250.000	36.11	11.16	47.27	74.00	-26.73	H	peak

**Remark:**

1. Measuring frequencies from 1 GHz to the 10th harmonic of highest fundamental frequency.
2. Radiated emissions measured in frequency above 1000MHz were made with an instrument using peak/average detector mode.
3. Average test would be performed if the peak result were greater than the average limit or as required by the applicant.
4. Data of measurement within this frequency range shown " --- " in the table above means the reading of emissions are attenuated more than 20dB below the permissible limits or the field strength is too small to be measured.
5. Measurements above show only up to 6 maximum emissions noted, or would be lesser, with " N/A " remark, if no specific emissions from the EUT are recorded (ie: margin>20dB from the applicable limit) and considered that's already beyond the background noise floor.





**Operation Mode:** TX / IEEE 802.11g / CH Mid

**Test Date:** 2013/10/4

**Temperature:** 26°C

**Tested by:** Francis Lee

**Humidity:** 56 % RH

**Polarity:** Ver. / Hor.

Freq. (MHz)	Reading (dBuV)	Correct Factor (dB/m)	Result (dBuV/m)	Limit (dBuV/m)	Margin (dB)	Ant. Pol H/V	Remark
1344.000	54.70	-7.74	46.96	74.00	-27.04	V	peak
1978.000	52.15	-1.65	50.50	74.00	-23.50	V	peak
2700.000	53.82	-1.47	52.35	74.00	-21.65	V	peak
2700.000	38.98	-1.47	37.51	54.00	-16.49	V	AVG
3815.000	36.32	3.36	39.68	74.00	-34.32	V	peak
4865.000	48.27	3.58	51.85	74.00	-22.15	V	peak
7305.000	39.37	10.52	49.89	74.00	-24.11	V	peak
1344.000	60.44	-8.34	52.10	74.00	-21.90	H	peak
1344.000	54.89	-8.34	46.55	54.00	-7.45	H	AVG
1514.000	59.76	-9.08	50.68	74.00	-23.32	H	peak
1680.000	58.31	-8.01	50.30	74.00	-23.70	H	peak
1848.000	55.54	-6.29	49.25	74.00	-24.75	H	peak
2850.000	51.00	-2.10	48.90	74.00	-25.10	H	peak
3800.000	36.65	5.10	41.75	74.00	-32.25	H	peak
4870.000	44.46	6.64	51.10	74.00	-22.90	H	peak
7310.000	37.97	11.77	49.74	74.00	-24.26	H	peak

**Remark:**

1. Measuring frequencies from 1 GHz to the 10th harmonic of highest fundamental frequency.
2. Radiated emissions measured in frequency above 1000MHz were made with an instrument using peak/average detector mode.
3. Average test would be performed if the peak result were greater than the average limit or as required by the applicant.
4. Data of measurement within this frequency range shown " --- " in the table above means the reading of emissions are attenuated more than 20dB below the permissible limits or the field strength is too small to be measured.
5. Measurements above show only up to 6 maximum emissions noted, or would be lesser, with " N/A " remark, if no specific emissions from the EUT are recorded (ie: margin>20dB from the applicable limit) and considered that's already beyond the background noise floor.



**Operation Mode:** TX / IEEE 802.11g / CH High

**Test Date:** 2013/10/4

**Temperature:** 26°C

**Tested by:** Francis Lee

**Humidity:** 56 % RH

**Polarity:** Ver. / Hor.

Freq. (MHz)	Reading (dBuV)	Correct Factor (dB/m)	Result (dBuV/m)	Limit (dBuV/m)	Margin (dB)	Ant. Pol H/V	Remark
1512.000	53.88	-5.20	48.68	74.00	-25.32	V	peak
2012.000	52.61	-1.57	51.04	74.00	-22.96	V	peak
2670.000	53.82	-1.68	52.14	74.00	-21.86	V	peak
2670.000	38.46	-1.68	36.78	54.00	-17.22	V	AVG
3820.000	36.47	3.24	39.71	74.00	-34.29	V	peak
4925.000	47.17	4.61	51.78	74.00	-22.22	V	peak
7390.000	38.64	11.22	49.86	74.00	-24.14	V	peak
1344.000	62.20	-8.34	53.86	74.00	-20.14	H	peak
1344.000	55.11	-8.34	46.77	54.00	-7.23	H	AVG
1512.000	59.81	-9.07	50.74	74.00	-23.26	H	peak
1680.000	58.55	-8.01	50.54	74.00	-23.46	H	peak
1848.000	55.09	-6.29	48.80	74.00	-25.20	H	peak
2872.000	51.00	-1.94	49.06	74.00	-24.94	H	peak
3820.000	37.28	5.12	42.40	74.00	-31.60	H	peak
4920.000	43.25	7.24	50.49	74.00	-23.51	H	peak
7375.000	39.51	11.44	50.95	74.00	-23.05	H	peak

**Remark:**

1. Measuring frequencies from 1 GHz to the 10th harmonic of highest fundamental frequency.
2. Radiated emissions measured in frequency above 1000MHz were made with an instrument using peak/average detector mode.
3. Average test would be performed if the peak result were greater than the average limit or as required by the applicant.
4. Data of measurement within this frequency range shown " --- " in the table above means the reading of emissions are attenuated more than 20dB below the permissible limits or the field strength is too small to be measured.
5. Measurements above show only up to 6 maximum emissions noted, or would be lesser, with " N/A " remark, if no specific emissions from the EUT are recorded (ie: margin>20dB from the applicable limit) and considered that's already beyond the background noise floor.



Operation Mode: TX / IEEE 802.11n HT20 mode / CH Low

Test Date: 2013/10/4

Temperature: 26°C

Tested by: Francis Lee

Humidity: 55 % RH

Polarity: Ver. / Hor.

Freq. (MHz)	Reading (dBuV)	Correct Factor (dB/m)	Result (dBuV/m)	Limit (dBuV/m)	Margin (dB)	Ant. Pol H/V	Remark
1344.000	53.77	-7.74	46.03	74.00	-27.97	V	peak
2004.000	52.11	-1.39	50.72	74.00	-23.28	V	peak
2890.000	51.17	-0.80	50.37	74.00	-23.63	V	peak
3215.000	42.56	-0.63	41.93	74.00	-32.07	V	peak
4825.000	43.97	2.68	46.65	74.00	-27.35	V	peak
7755.000	36.51	10.95	47.46	74.00	-26.54	V	peak
1344.000	59.93	-8.34	51.59	74.00	-22.41	H	peak
1684.000	59.66	-7.94	51.72	74.00	-22.28	H	peak
2084.000	53.85	-4.20	49.65	74.00	-24.35	H	peak
2810.000	51.59	-2.40	49.19	74.00	-24.81	H	peak
3830.000	36.99	5.14	42.13	74.00	-31.87	H	peak
4825.000	40.02	5.88	45.90	74.00	-28.10	H	peak
7345.000	34.31	11.59	45.90	74.00	-28.10	H	peak

Remark:

1. Measuring frequencies from 1 GHz to the 10th harmonic of highest fundamental frequency.
2. Radiated emissions measured in frequency above 1000MHz were made with an instrument using peak/average detector mode.
3. Average test would be performed if the peak result were greater than the average limit or as required by the applicant.
4. Data of measurement within this frequency range shown " --- " in the table above means the reading of emissions are attenuated more than 20dB below the permissible limits or the field strength is too small to be measured.
5. Measurements above show only up to 6 maximum emissions noted, or would be lesser, with " N/A " remark, if no specific emissions from the EUT are recorded (ie: margin>20dB from the applicable limit) and considered that's already beyond the background noise floor.



**Operation Mode:** TX / IEEE 802.11n HT20 mode / CH Mid

**Test Date:** 2013/10/3

**Temperature:** 26°C

**Tested by:** Francis Lee

**Humidity:** 56 % RH

**Polarity:** Ver. / Hor.

Freq. (MHz)	Reading (dBuV)	Correct Factor (dB/m)	Result (dBuV/m)	Limit (dBuV/m)	Margin (dB)	Ant. Pol H/V	Remark
1674.000	53.30	-5.42	47.88	74.00	-26.12	V	peak
1996.000	52.49	-1.36	51.13	74.00	-22.87	V	peak
2962.000	50.98	-1.05	49.93	74.00	-24.07	V	peak
3250.000	40.56	-0.01	40.55	74.00	-33.45	V	peak
4880.000	42.55	3.92	46.47	74.00	-27.53	V	peak
7175.000	36.40	9.93	46.33	74.00	-27.67	V	peak
1350.000	56.99	-8.19	48.80	74.00	-25.20	H	peak
1680.000	59.77	-8.01	51.76	74.00	-22.24	H	peak
2106.000	53.71	-3.77	49.94	74.00	-24.06	H	peak
2810.000	50.59	-2.40	48.19	74.00	-25.81	H	peak
3850.000	37.45	5.16	42.61	74.00	-31.39	H	peak
4880.000	38.75	6.81	45.56	74.00	-28.44	H	peak
7295.000	34.29	11.75	46.04	74.00	-27.96	H	peak

**Remark:**

1. Measuring frequencies from 1 GHz to the 10th harmonic of highest fundamental frequency.
2. Radiated emissions measured in frequency above 1000MHz were made with an instrument using peak/average detector mode.
3. Average test would be performed if the peak result were greater than the average limit or as required by the applicant.
4. Data of measurement within this frequency range shown " --- " in the table above means the reading of emissions are attenuated more than 20dB below the permissible limits or the field strength is too small to be measured.
5. Measurements above show only up to 6 maximum emissions noted, or would be lesser, with " N/A " remark, if no specific emissions from the EUT are recorded (ie: margin>20dB from the applicable limit) and considered that's already beyond the background noise floor.



**Operation Mode:** TX / IEEE 802.11n HT20 mode / CH High

**Test Date:** 2013/10/3

**Temperature:** 26°C

**Tested by:** Francis Lee

**Humidity:** 56 % RH

**Polarity:** Ver. / Hor.

Freq. (MHz)	Reading (dBuV)	Correct Factor (dB/m)	Result (dBuV/m)	Limit (dBuV/m)	Margin (dB)	Ant. Pol H/V	Remark
1350.000	53.98	-7.62	46.36	74.00	-27.64	V	peak
1984.000	52.48	-1.55	50.93	74.00	-23.07	V	peak
2930.000	50.78	-0.85	49.93	74.00	-24.07	V	peak
3805.000	36.74	3.58	40.32	74.00	-33.68	V	peak
4920.000	46.30	4.56	50.86	74.00	-23.14	V	peak
7595.000	34.74	11.89	46.63	74.00	-27.37	V	peak
1344.000	58.85	-8.34	50.51	74.00	-23.49	H	peak
1680.000	57.40	-8.01	49.39	74.00	-24.61	H	peak
2132.000	52.91	-3.71	49.20	74.00	-24.80	H	peak
2816.000	51.52	-2.36	49.16	74.00	-24.84	H	peak
3865.000	36.81	5.18	41.99	74.00	-32.01	H	peak
4920.000	43.06	7.24	50.30	74.00	-23.70	H	peak
7310.000	34.32	11.77	46.09	74.00	-27.91	H	peak

**Remark:**

1. Measuring frequencies from 1 GHz to the 10th harmonic of highest fundamental frequency.
2. Radiated emissions measured in frequency above 1000MHz were made with an instrument using peak/average detector mode.
3. Average test would be performed if the peak result were greater than the average limit or as required by the applicant.
4. Data of measurement within this frequency range shown " --- " in the table above means the reading of emissions are attenuated more than 20dB below the permissible limits or the field strength is too small to be measured.
5. Measurements above show only up to 6 maximum emissions noted, or would be lesser, with " N/A " remark, if no specific emissions from the EUT are recorded (ie: margin>20dB from the applicable limit) and considered that's already beyond the background noise floor.



**Operation Mode:** TX / IEEE 802.11n HT40 mode / CH Low

**Test Date:** 2013/10/3

**Temperature:** 26°C

**Tested by:** Francis Lee

**Humidity:** 56 % RH

**Polarity:** Ver. / Hor.

Freq. (MHz)	Reading (dBuV)	Correct Factor (dB/m)	Result (dBuV/m)	Limit (dBuV/m)	Margin (dB)	Ant. Pol H/V	Remark
1512.000	53.52	-5.20	48.32	74.00	-25.68	V	peak
2014.000	52.80	-1.62	51.18	74.00	-22.82	V	peak
2898.000	51.32	-0.69	50.63	74.00	-23.37	V	peak
3230.000	41.31	-0.36	40.95	74.00	-33.05	V	peak
4840.000	42.18	3.02	45.20	74.00	-28.80	V	peak
7600.000	34.45	11.91	46.36	74.00	-27.64	V	peak
1344.000	58.43	-8.34	50.09	74.00	-23.91	H	peak
1680.000	59.75	-8.01	51.74	74.00	-22.26	H	peak
2156.000	52.98	-3.66	49.32	74.00	-24.68	H	peak
2890.000	51.08	-1.80	49.28	74.00	-24.72	H	peak
3775.000	36.20	4.77	40.97	74.00	-33.03	H	peak
4845.000	38.36	6.21	44.57	74.00	-29.43	H	peak
7285.000	35.41	11.62	47.03	74.00	-26.97	H	peak

**Remark:**

1. Measuring frequencies from 1 GHz to the 10th harmonic of highest fundamental frequency.
2. Radiated emissions measured in frequency above 1000MHz were made with an instrument using peak/average detector mode.
3. Average test would be performed if the peak result were greater than the average limit or as required by the applicant.
4. Data of measurement within this frequency range shown " --- " in the table above means the reading of emissions are attenuated more than 20dB below the permissible limits or the field strength is too small to be measured.
5. Measurements above show only up to 6 maximum emissions noted, or would be lesser, with " N/A " remark, if no specific emissions from the EUT are recorded (ie: margin>20dB from the applicable limit) and considered that's already beyond the background noise floor.



Operation Mode: TX / IEEE 802.11n HT40 mode / CH Mid

Test Date: 2013/10/3

Temperature: 26°C

Tested by: Francis Lee

Humidity: 56 % RH

Polarity: Ver. / Hor.

Freq. (MHz)	Reading (dBuV)	Correct Factor (dB/m)	Result (dBuV/m)	Limit (dBuV/m)	Margin (dB)	Ant. Pol H/V	Remark
1584.000	53.46	-4.87	48.59	74.00	-25.41	V	peak
2016.000	52.79	-1.66	51.13	74.00	-22.87	V	peak
2870.000	51.70	-1.09	50.61	74.00	-23.39	V	peak
3250.000	39.17	-0.01	39.16	74.00	-34.84	V	peak
4880.000	40.60	3.92	44.52	74.00	-29.48	V	peak
7580.000	35.99	11.84	47.83	74.00	-26.17	V	peak
1344.000	59.76	-8.34	51.42	74.00	-22.58	H	peak
1512.000	58.62	-9.07	49.55	74.00	-24.45	H	peak
1680.000	59.87	-8.01	51.86	74.00	-22.14	H	peak
2122.000	52.98	-3.73	49.25	74.00	-24.75	H	peak
2854.000	51.28	-2.07	49.21	74.00	-24.79	H	peak
3820.000	36.36	5.12	41.48	74.00	-32.52	H	peak
4885.000	37.39	6.90	44.29	74.00	-29.71	H	peak
7310.000	34.63	11.77	46.40	74.00	-27.60	H	peak

Remark:

1. Measuring frequencies from 1 GHz to the 10th harmonic of highest fundamental frequency.
2. Radiated emissions measured in frequency above 1000MHz were made with an instrument using peak/average detector mode.
3. Average test would be performed if the peak result were greater than the average limit or as required by the applicant.
4. Data of measurement within this frequency range shown " --- " in the table above means the reading of emissions are attenuated more than 20dB below the permissible limits or the field strength is too small to be measured.
5. Measurements above show only up to 6 maximum emissions noted, or would be lesser, with " N/A " remark, if no specific emissions from the EUT are recorded (ie: margin>20dB from the applicable limit) and considered that's already beyond the background noise floor.



**Operation Mode:** TX / IEEE 802.11n HT40 mode / CH High

**Test Date:** 2013/10/4

**Temperature:** 26°C

**Tested by:** Francis Lee

**Humidity:** 56 % RH

**Polarity:** Ver. / Hor.

Freq. (MHz)	Reading (dBuV)	Correct Factor (dB/m)	Result (dBuV/m)	Limit (dBuV/m)	Margin (dB)	Ant. Pol H/V	Remark
1474.000	53.54	-5.62	47.92	74.00	-26.08	V	peak
1988.000	52.20	-1.49	50.71	74.00	-23.29	V	peak
2918.000	51.20	-0.77	50.43	74.00	-23.57	V	peak
3600.000	37.47	2.93	40.40	74.00	-33.60	V	peak
4905.000	41.92	4.42	46.34	74.00	-27.66	V	peak
7620.000	35.38	11.68	47.06	74.00	-26.94	V	peak
1344.000	60.96	-8.34	52.62	74.00	-21.38	H	peak
1344.000	57.02	-8.34	48.68	54.00	-5.32	H	AVG
1680.000	60.08	-8.01	52.07	74.00	-21.93	H	peak
1680.000	55.39	-8.01	47.38	54.00	-6.62	H	AVG
2142.000	52.64	-3.69	48.95	74.00	-25.05	H	peak
2882.000	51.51	-1.86	49.65	74.00	-24.35	H	peak
3810.000	36.47	5.11	41.58	74.00	-32.42	H	peak
4900.000	37.80	7.15	44.95	74.00	-29.05	H	peak
7305.000	34.81	11.79	46.60	74.00	-27.40	H	peak

**Remark:**

1. Measuring frequencies from 1 GHz to the 10th harmonic of highest fundamental frequency.
2. Radiated emissions measured in frequency above 1000MHz were made with an instrument using peak/average detector mode.
3. Average test would be performed if the peak result were greater than the average limit or as required by the applicant.
4. Data of measurement within this frequency range shown " --- " in the table above means the reading of emissions are attenuated more than 20dB below the permissible limits or the field strength is too small to be measured.
5. Measurements above show only up to 6 maximum emissions noted, or would be lesser, with " N/A " remark, if no specific emissions from the EUT are recorded (ie: margin>20dB from the applicable limit) and considered that's already beyond the background noise floor.





## 7.7 POWERLINE CONDUCTED EMISSIONS

### LIMIT

According to §15.207(a), except as shown in paragraphs (b) and (c) of this section, for an intentional radiator that is designed to be connected to the public utility (AC) power line, the radio frequency voltage that is conducted back onto the AC power line on any frequency or frequencies within the band 150 kHz to 30 MHz shall not exceed the limits in the following table, as measured using a 50  $\mu$ H/50 ohms line impedance stabilization network (LISN). Compliance with the provisions of this paragraph shall be based on the measurement of the radio frequency voltage between each power line and ground at the power terminal. The lower limit applies at the boundary between the frequency ranges.

Frequency Range (MHz)	Limits (dB $\mu$ V)	
	Quasi-peak	Average
0.15 to 0.50	66 to 56*	56 to 46*
0.50 to 5	56	46
5 to 30	60	50

\* Decreases with the logarithm of the frequency.

### TEST CONFIGURATION

See test photographs attached in Appendix II for the actual connections between EUT and support equipment.

### TEST PROCEDURE

1. The EUT was placed on a table, which is 0.8m above ground plane.
2. Maximum procedure was performed on the six highest emissions to ensure EUT compliance.
3. Repeat above procedures until all frequency measured were complete.

### TEST RESULTS

The initial step in collecting conducted data is a spectrum analyzer peak scan of the measurement range. Significant peaks are then marked as shown on the following data page, and these signals are then quasi-peaked.



**TEST DATA**

<b>Test Mode</b>	Charging	<b>6dB Bandwidth</b>	9 kHz
<b>Environmental Conditions</b>	25°C, 57% RH	<b>Test Date:</b>	2013/10/22
<b>Tested By</b>	Louis.Shen	<b>Line</b>	L1

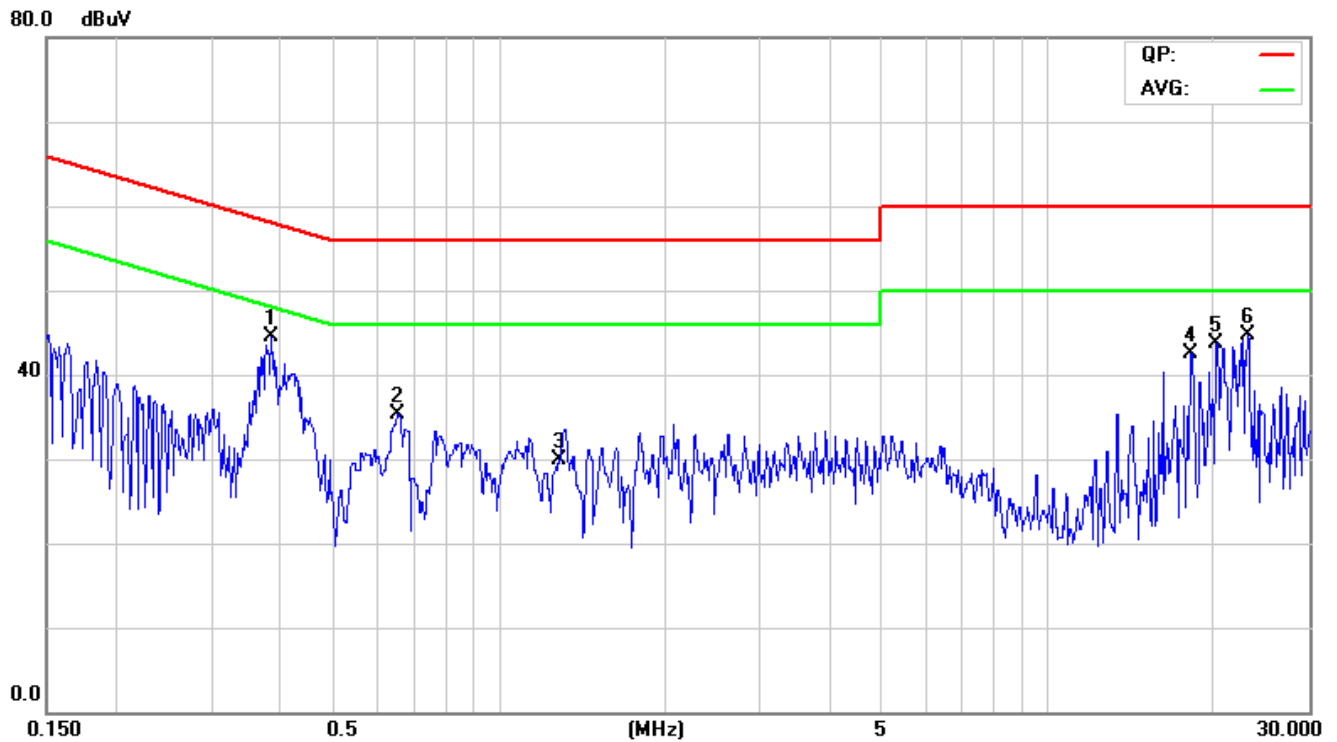

NO.	Frequency (MHz)	QuasiPeak			Average			QuasiPeak			Average			Remark (Pass/Fail)
		reading	reading	Correction factor	reading	reading	Correction factor	limit	limit	margin	limit	limit	margin	
1	0.3842	30.05	24.18	9.65	39.70	33.83	58.19	48.19	-18.49	-14.36	Pass			
2	0.6546	21.96	17.16	9.64	31.60	26.80	56.00	46.00	-24.40	-19.20	Pass			
3	1.2714	18.31	11.30	9.70	28.01	21.00	56.00	46.00	-27.99	-25.00	Pass			
4	18.2428	31.15	26.07	10.03	41.18	36.10	60.00	50.00	-18.82	-13.90	Pass			
5	20.2588	32.88	28.35	10.04	42.92	38.39	60.00	50.00	-17.08	-11.61	Pass			
6*	23.1294	37.02	32.89	10.08	47.10	42.97	60.00	50.00	-12.90	-7.03	Pass			

**REMARKS:** L1 = Line One (Live Line)



<b>Test Mode</b>	Charging	<b>6dB Bandwidth</b>	9 kHz
<b>Environmental Conditions</b>	25°C, 57% RH	<b>Test Date:</b>	2013/10/22
<b>Tested By</b>	Louis.Shen	<b>Line</b>	L2

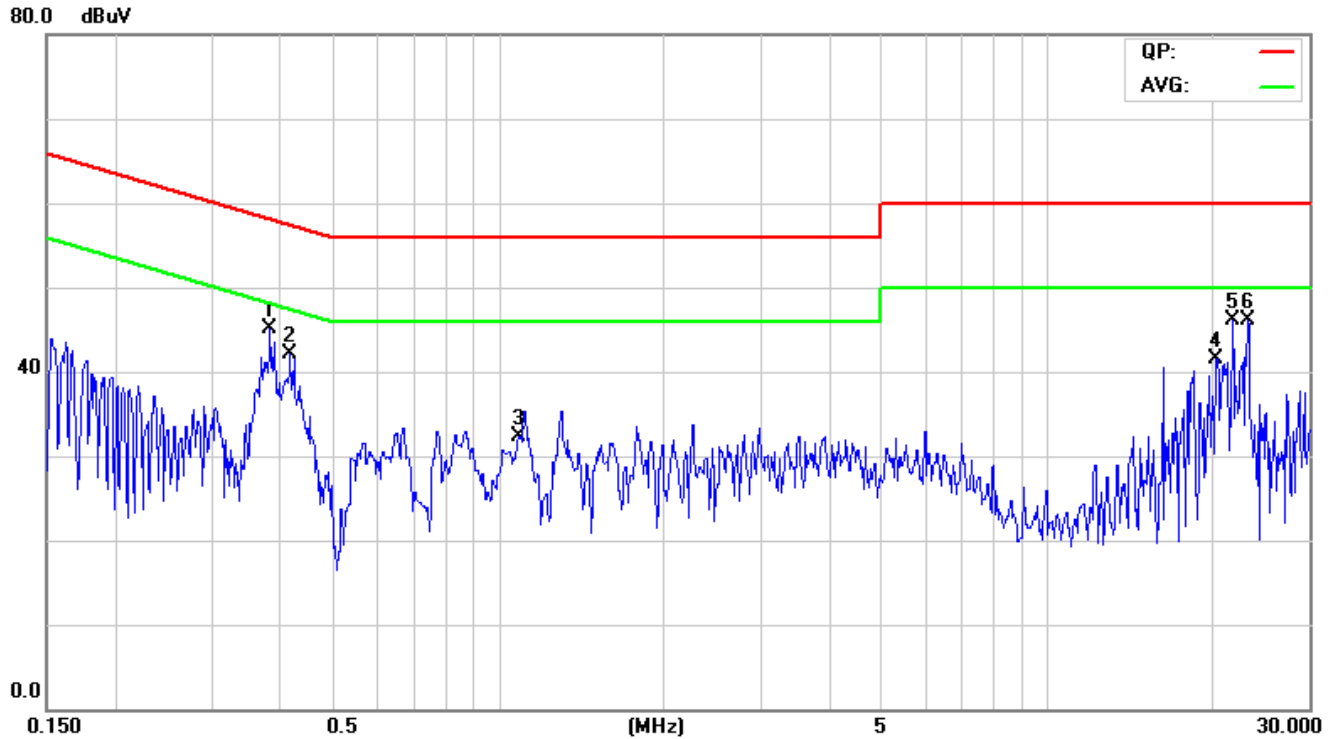

NO.	Frequency (MHz)	QuasiPeak reading (dBuV)	Average reading (dBuV)	Correction factor (dB)	QuasiPeak result (dBuV)	Average result (dBuV)	QuasiPeak limit (dBuV)	Average limit (dBuV)	QuasiPeak margin (dB)	Average margin (dB)	Remark (Pass/Fail)
1	0.3824	31.47	26.37	9.65	41.12	36.02	58.23	48.23	-17.11	-12.21	Pass
2	0.4168	28.32	21.37	9.65	37.97	31.02	57.51	47.51	-19.54	-16.49	Pass
3	1.0804	20.49	15.29	9.68	30.17	24.97	56.00	46.00	-25.83	-21.03	Pass
4	20.2580	32.74	28.18	10.04	42.78	38.22	60.00	50.00	-17.22	-11.78	Pass
5	21.6647	34.82	30.80	10.06	44.88	40.86	60.00	50.00	-15.12	-9.14	Pass
6*	23.1291	37.09	32.92	10.08	47.17	43.00	60.00	50.00	-12.83	-7.00	Pass

**REMARKS:** L2 = Line Two (Neutral Line)



## APPENDIX I PHOTOGRAPHS OF TEST SETUP

### Radiated Emission Set up Photos Below 1GHz

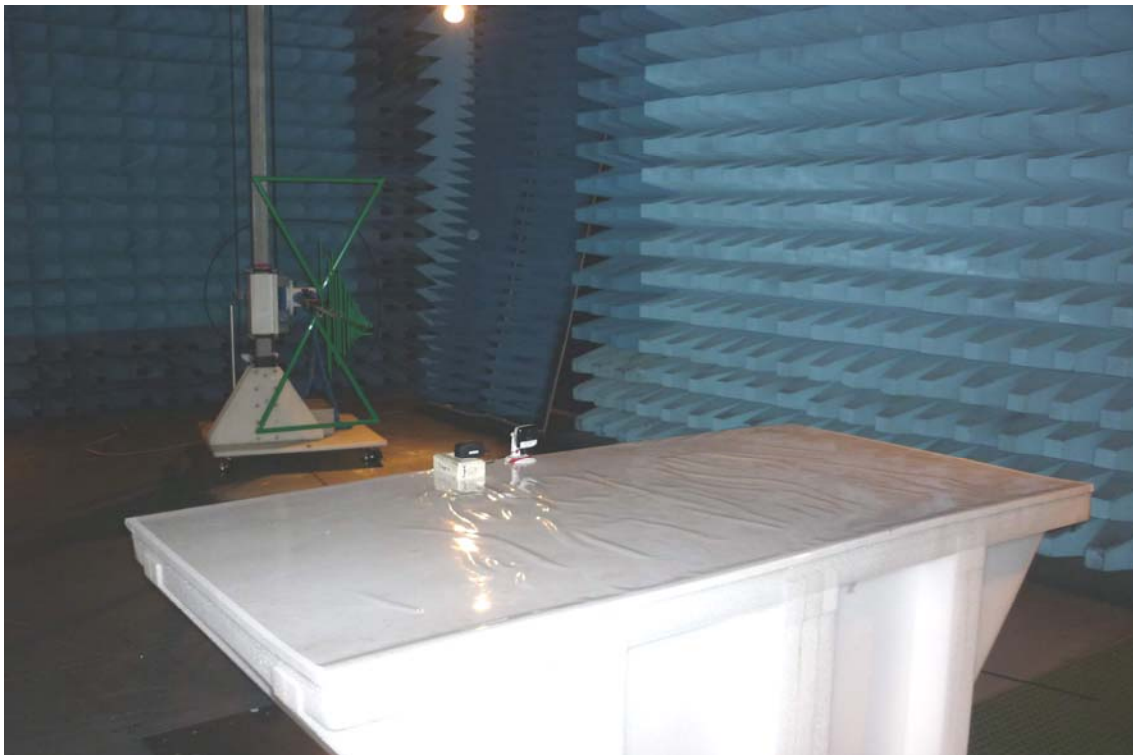
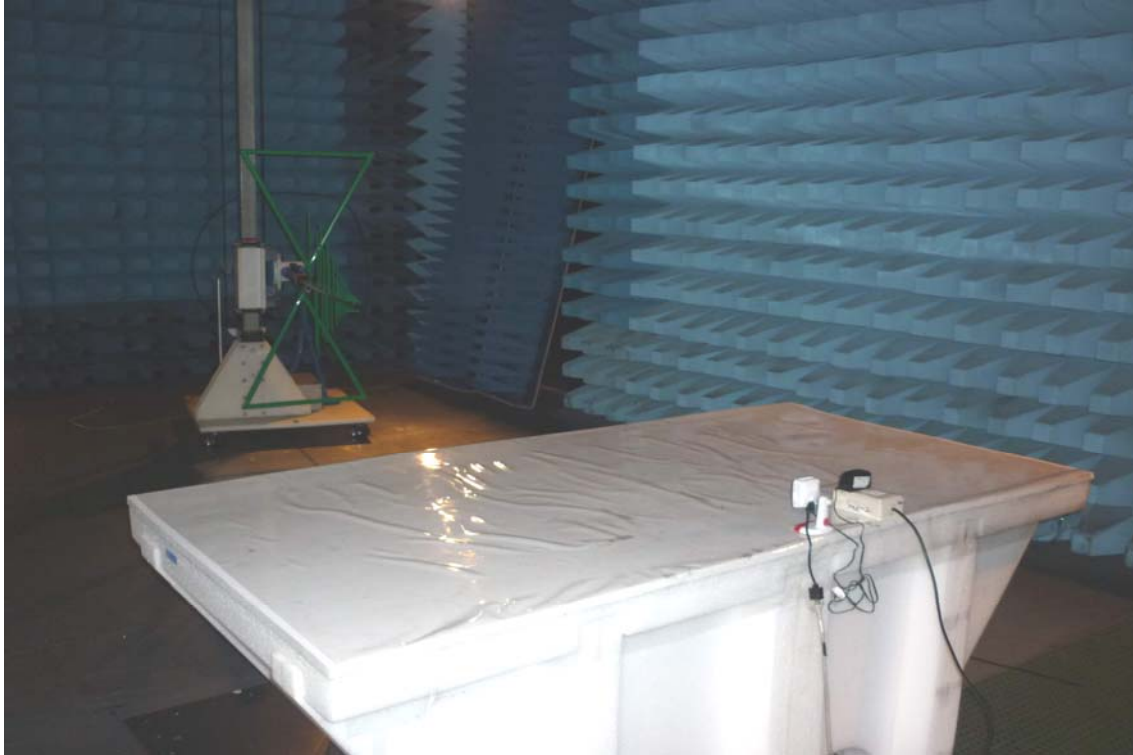



## Above 1GHz





## Conducted Emission Setup Photos

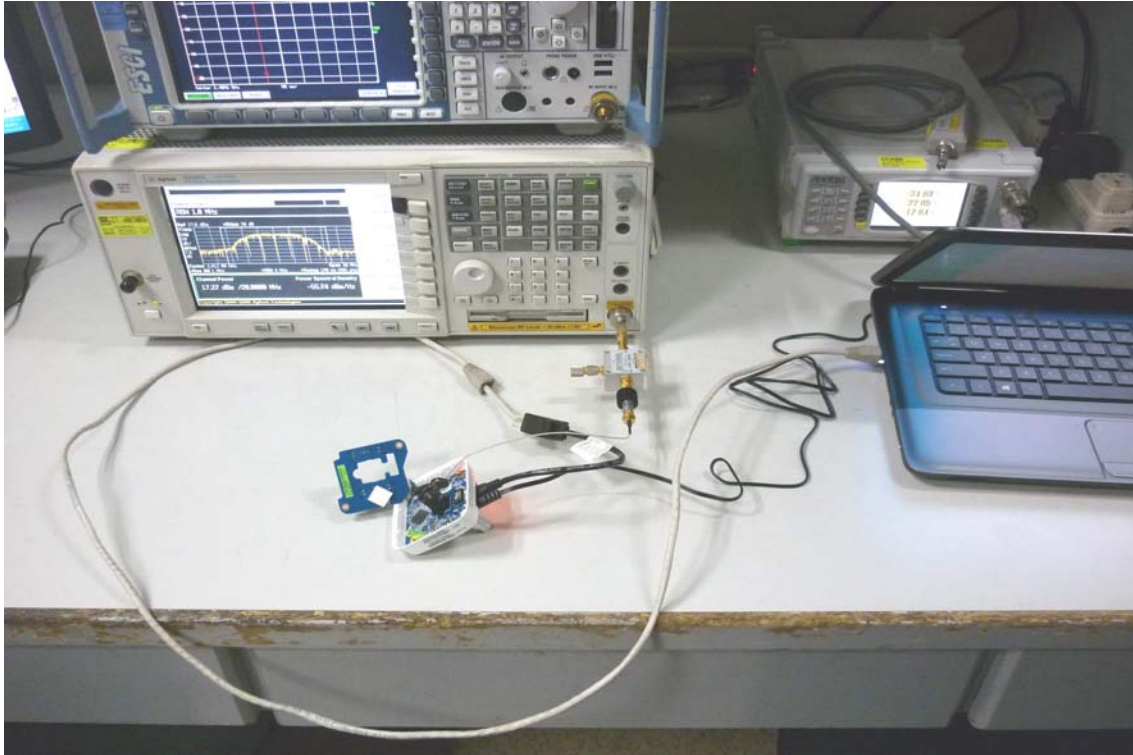



## Powerline Conducted Emissions Setup Photos

