

802.11a Power Spectral Density – CDD Mode Ant 1

Channel 52 (5260MHz)

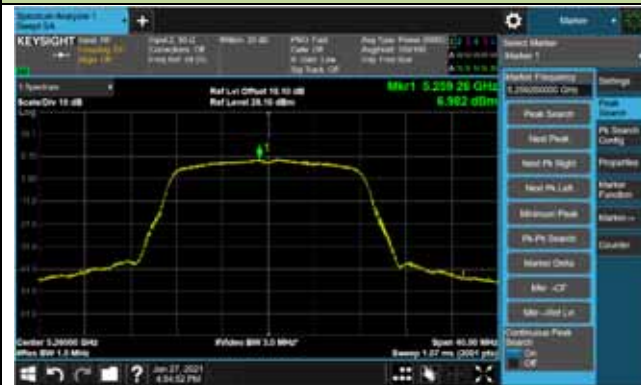

Channel 60 (5300MHz)

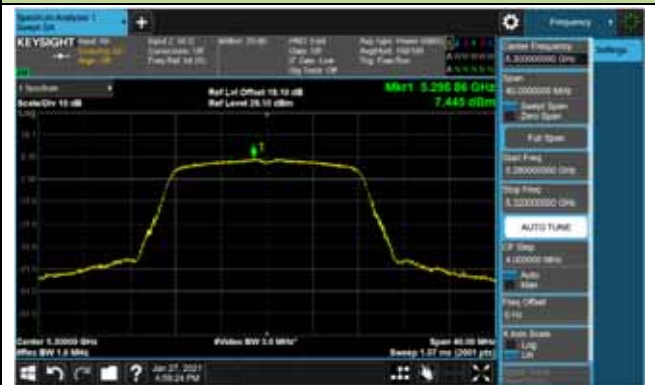

Channel 64 (5320MHz)



Channel 100 (5500MHz)



Channel 116 (5580MHz)

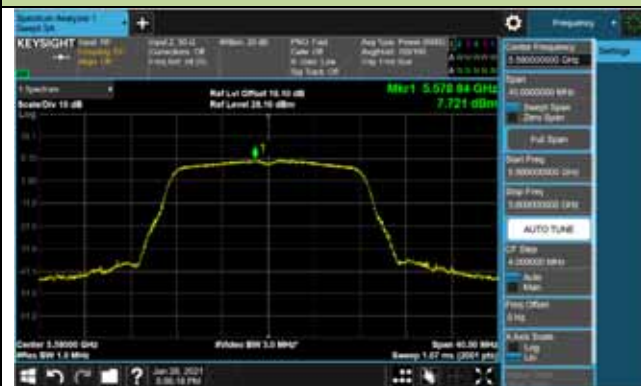

Channel 140 (5700MHz)

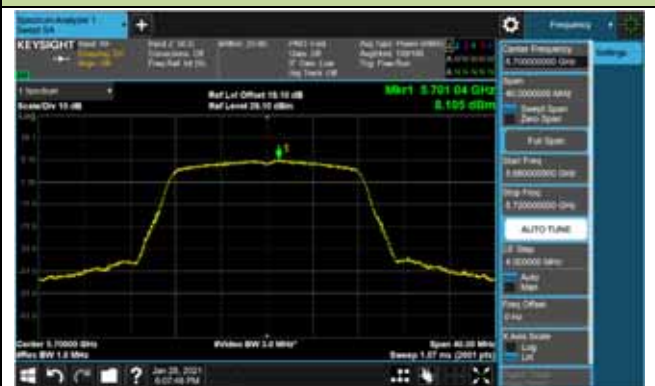

Channel 144 (5720MHz)

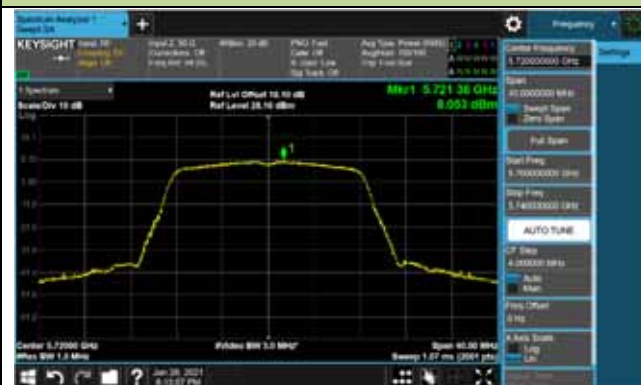

802.11n-HT20 Power Spectral Density –CDD Mode Ant 1

Channel 52 (5260MHz)



Channel 60 (5300MHz)

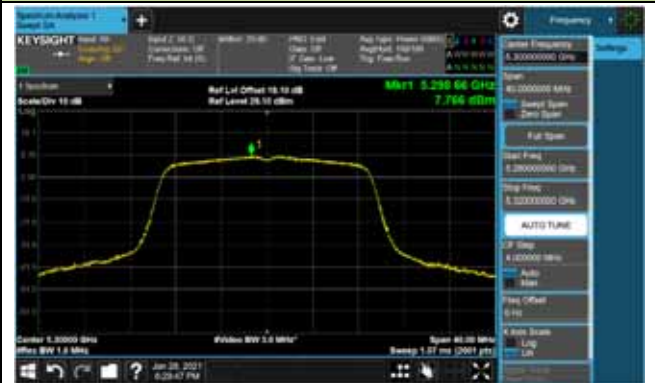

Channel 64 (5320MHz)



Channel 100 (5500MHz)

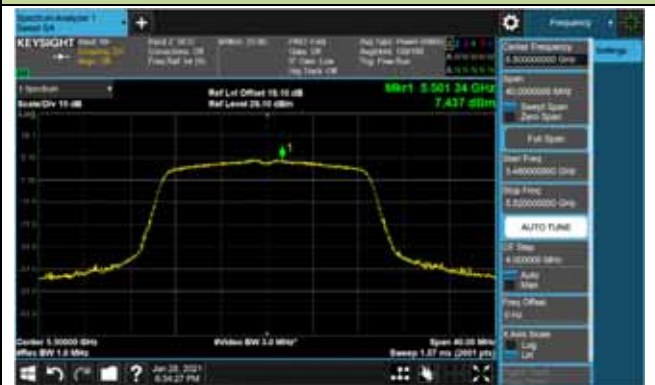

Channel 116 (5580MHz)

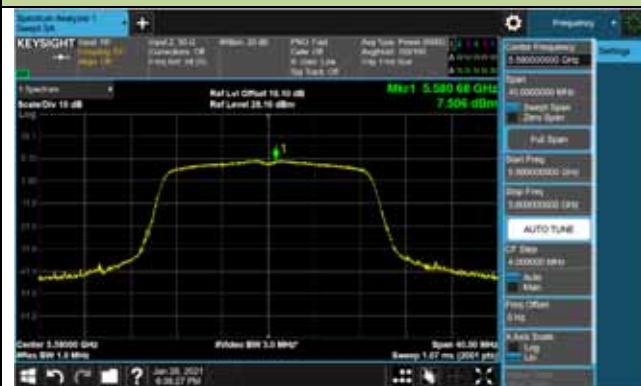

Channel 140 (5700MHz)

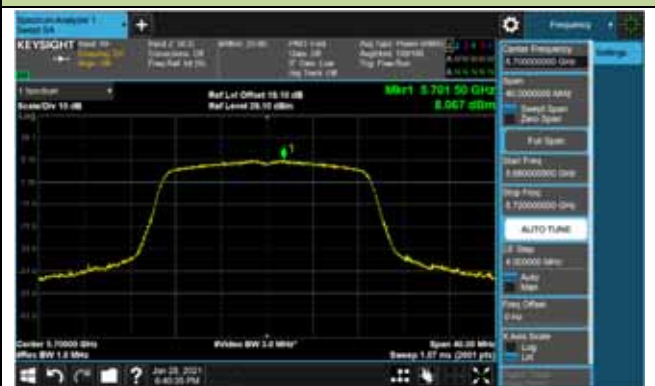

Channel 144 (5720MHz)

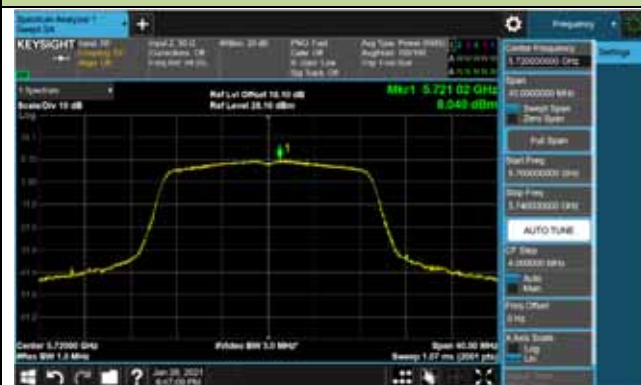

802.11n-HT40 Power Spectral Density –CDD Mode Ant 1

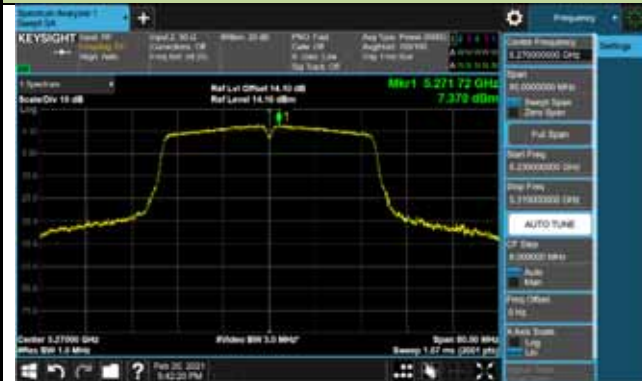
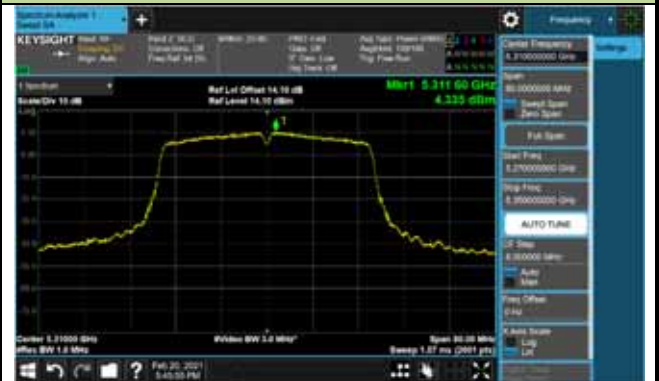
Channel 54 (5270MHz)

Channel 62 (5310MHz)

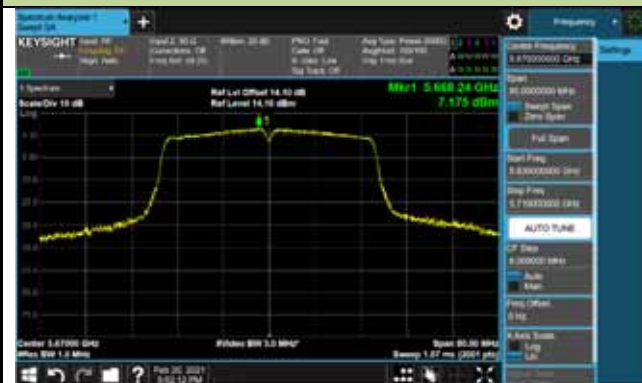
Channel 102 (5510MHz)

Channel 110 (5550MHz)

Channel 134 (5670MHz)

Channel 142 (5710MHz)

802.11ac-VHT20 Power Spectral Density –CDD Mode Ant 1

Channel 52 (5260MHz)

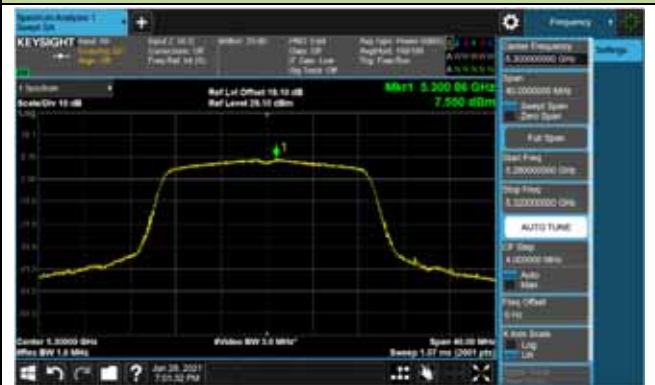

Channel 60 (5300MHz)



Channel 64 (5320MHz)

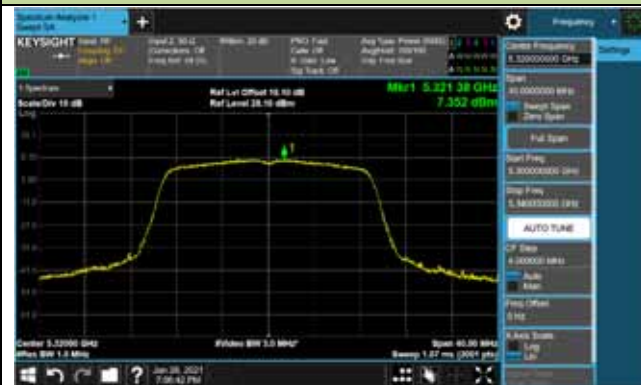

Channel 100 (5500MHz)

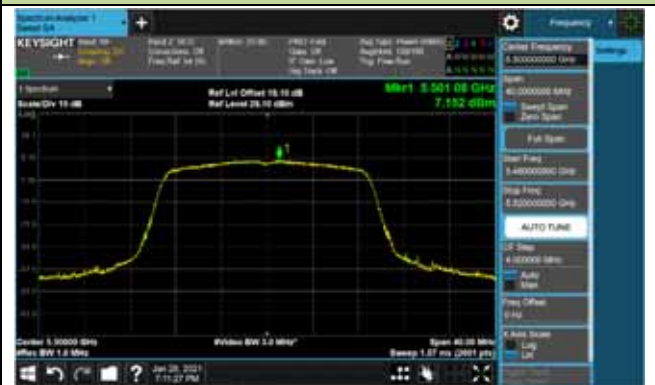

Channel 116 (5580MHz)



Channel 140 (5700MHz)

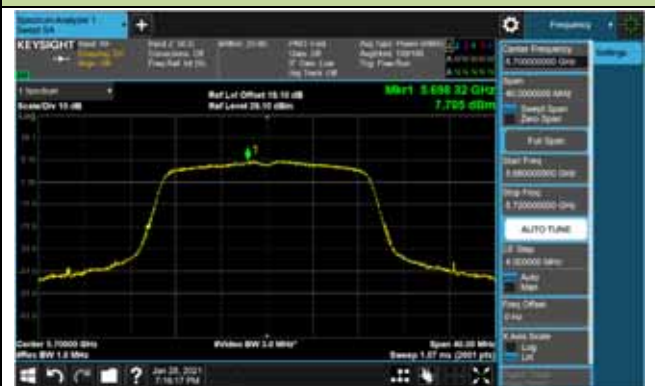

Channel 144 (5720MHz)

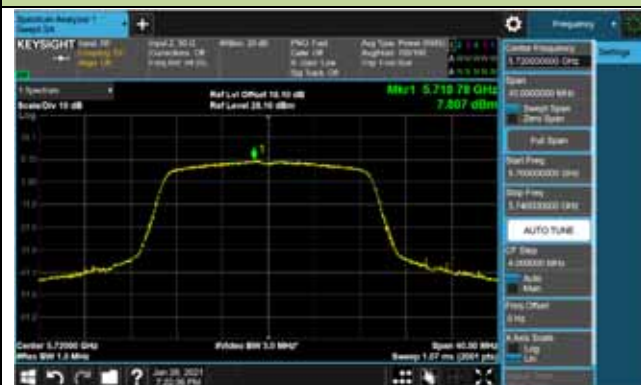

802.11ac-VHT40 Power Spectral Density –CDD Mode Ant 1

Channel 54 (5270MHz)



Channel 62 (5310MHz)



Channel 102 (5510MHz)

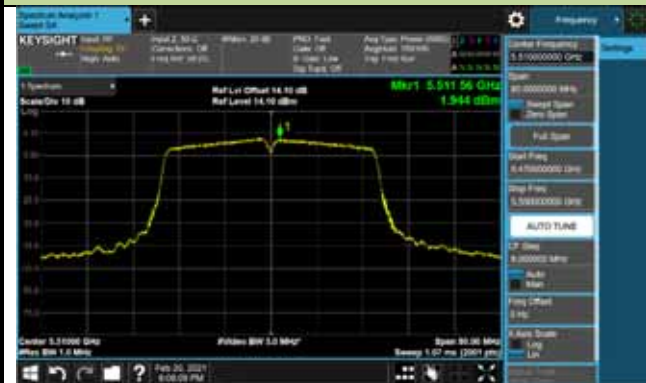

Channel 110 (5550MHz)

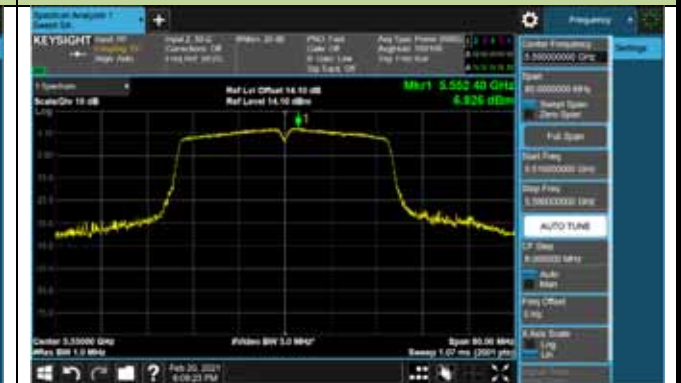

Channel 134 (5670MHz)

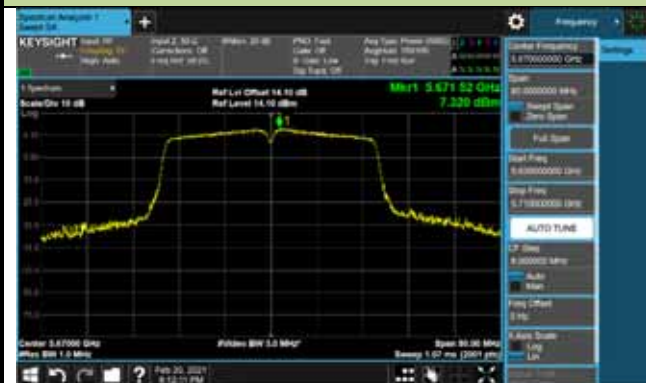

Channel 142 (5710MHz)

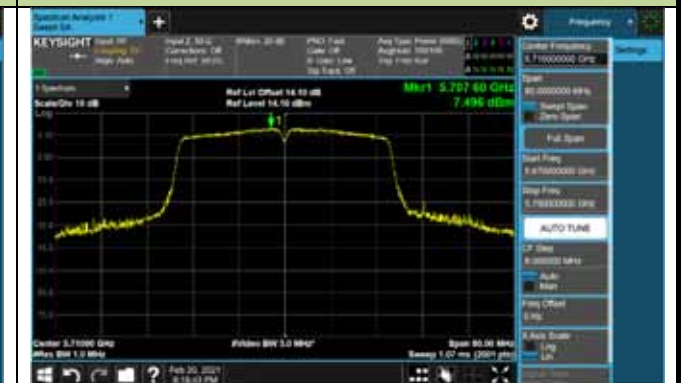

802.11ac-VHT80 Power Spectral Density –CDD Mode Ant 1

Channel 58 (5290MHz)



Channel 106 (5530MHz)



Channel 122 (5610MHz)



Channel 138(5690MHz)

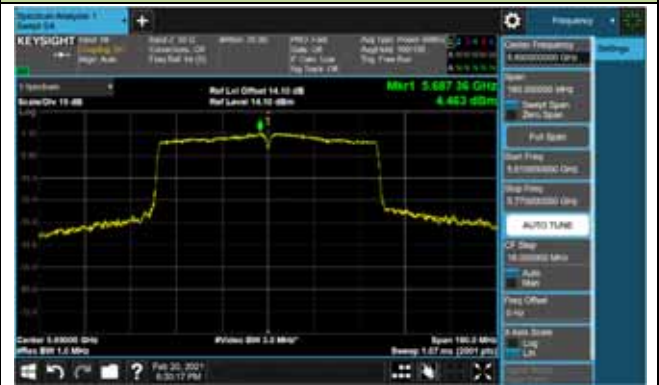

802.11n-HT20 Power Spectral Density – Beamforming Mode Ant 0

Channel 52 (5260MHz)

Channel 60 (5300MHz)

Channel 64 (5320MHz)

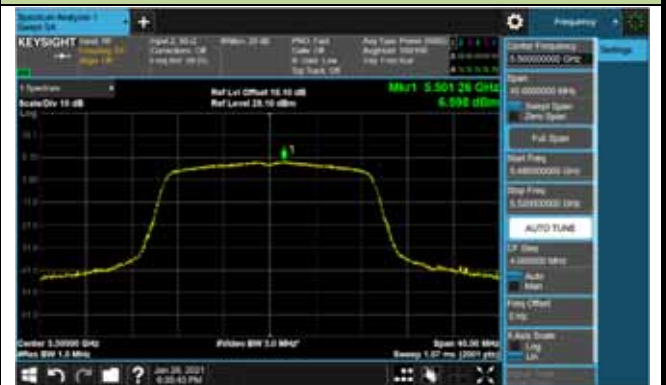
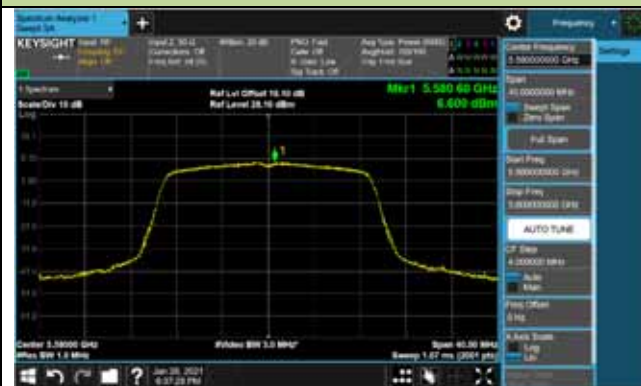
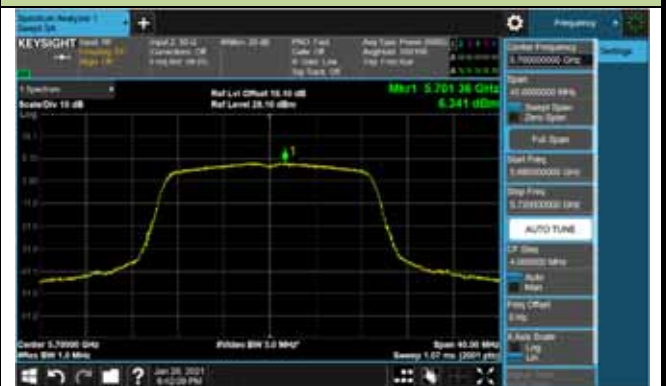
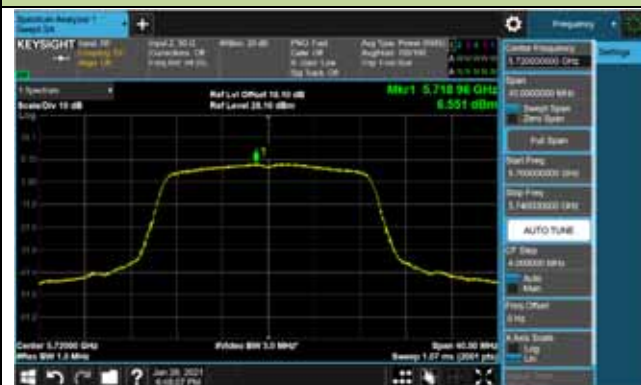
Channel 100 (5500MHz)

Channel 116 (5580MHz)

Channel 140 (5700MHz)

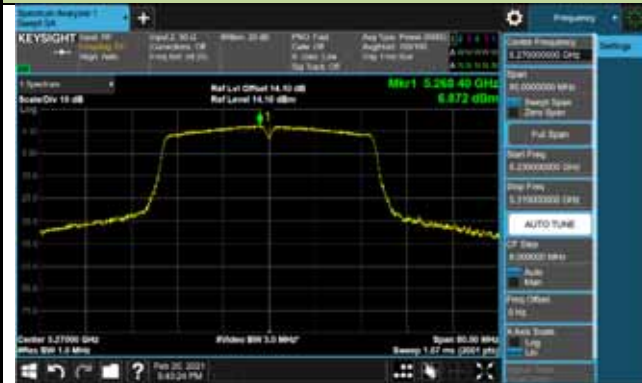
Channel 144 (5720MHz)

802.11n-HT40 Power Spectral Density –Beamforming Mode Ant 0

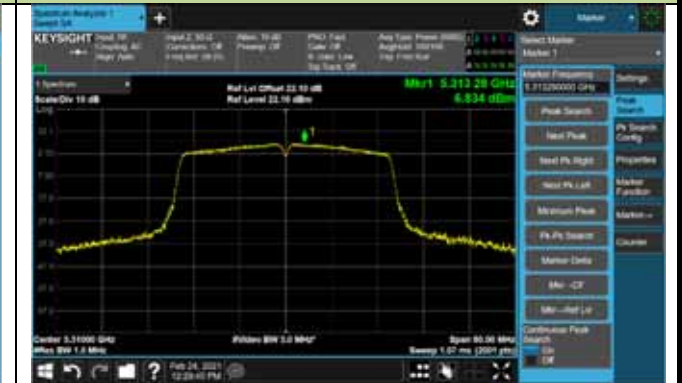
Channel 54 (5270MHz)



Channel 62 (5310MHz)



Channel 102 (5510MHz)

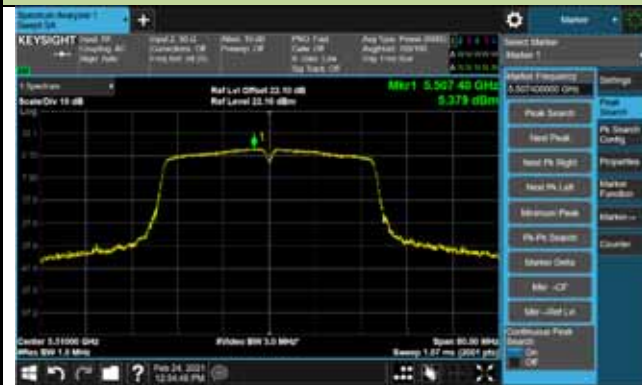

Channel 110 (5550MHz)

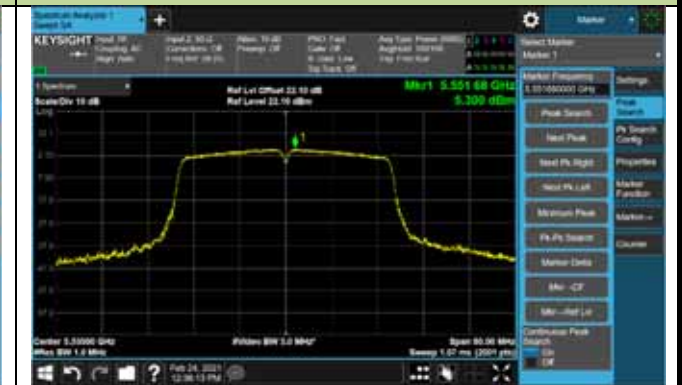

Channel 134 (5670MHz)



Channel 142 (5710MHz)

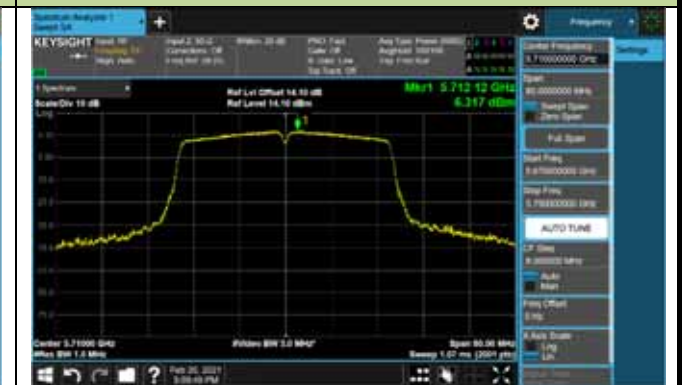

802.11ac-VHT20 Power Spectral Density –Beamforming Mode Ant 0

Channel 52 (5260MHz)

Channel 60 (5300MHz)

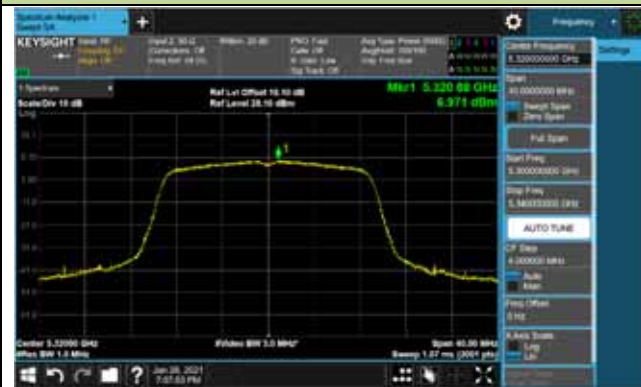
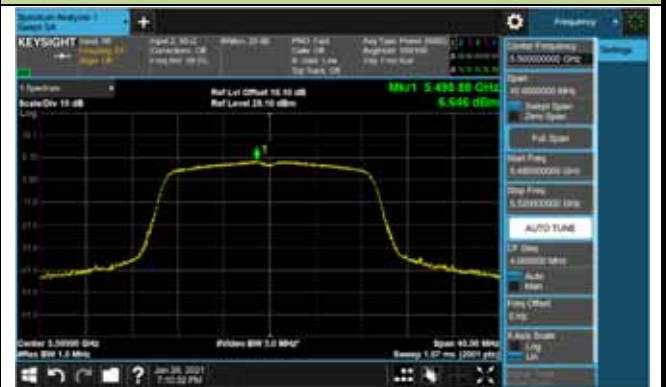
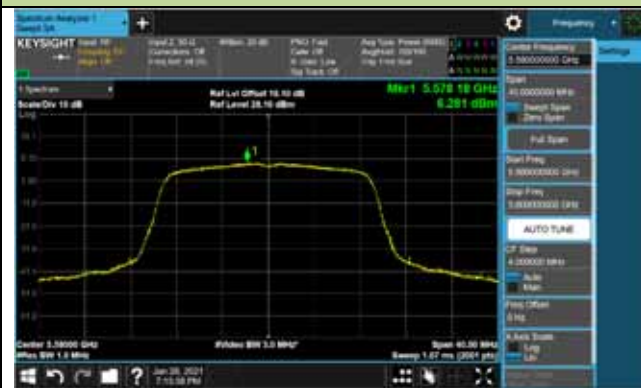
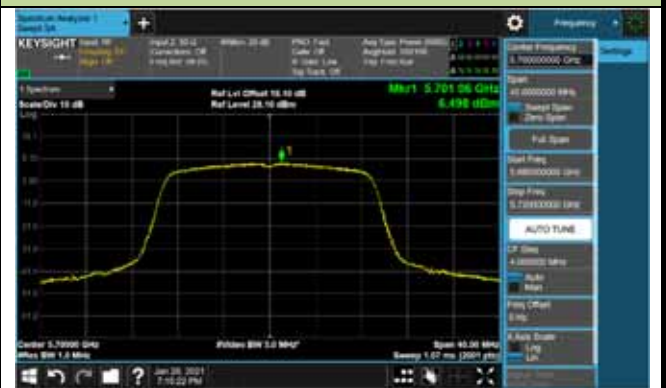
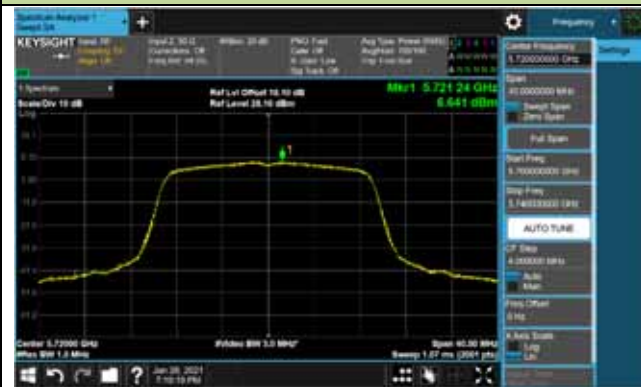
Channel 64 (5320MHz)

Channel 100 (5500MHz)

Channel 116 (5580MHz)

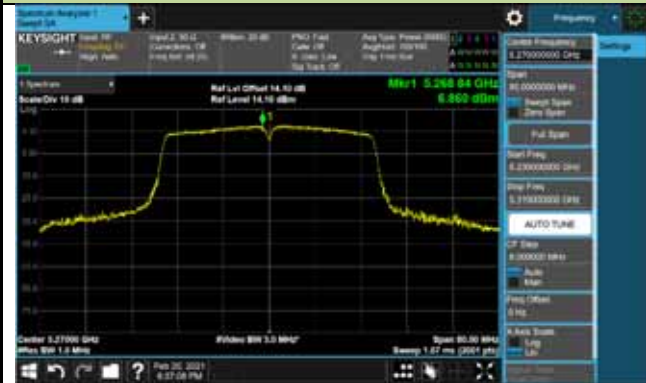
Channel 140 (5700MHz)

Channel 144 (5720MHz)

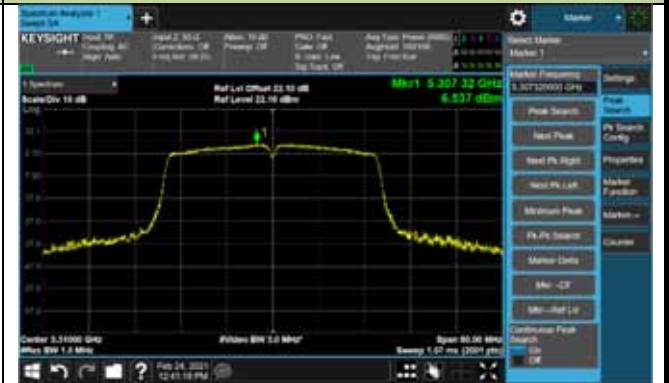
802.11ac-VHT40 Power Spectral Density –Beamforming Mode Ant 0

Channel 54 (5270MHz)



Channel 62 (5310MHz)



Channel 102 (5510MHz)

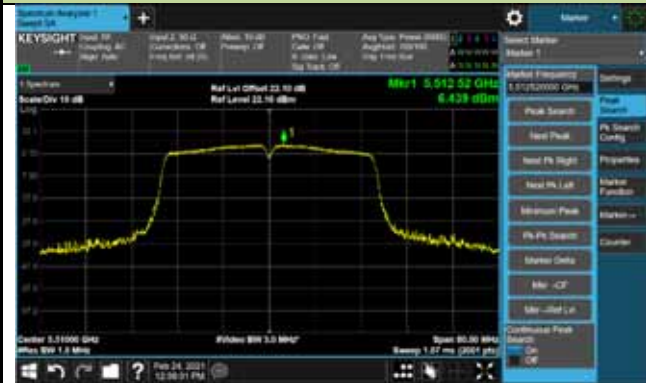

Channel 110 (5550MHz)



Channel 134 (5670MHz)



Channel 142 (5710MHz)

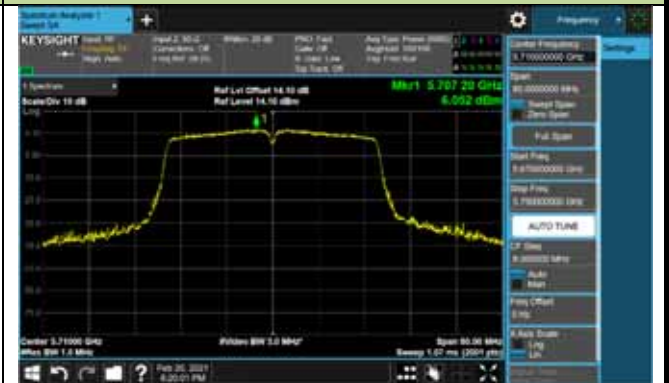

802.11ac-VHT80 Power Spectral Density –Beamforming Mode Ant 0

Channel 58 (5290MHz)

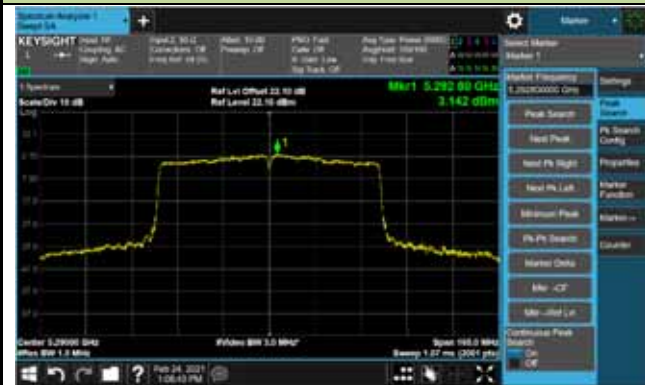

Channel 106 (5530MHz)

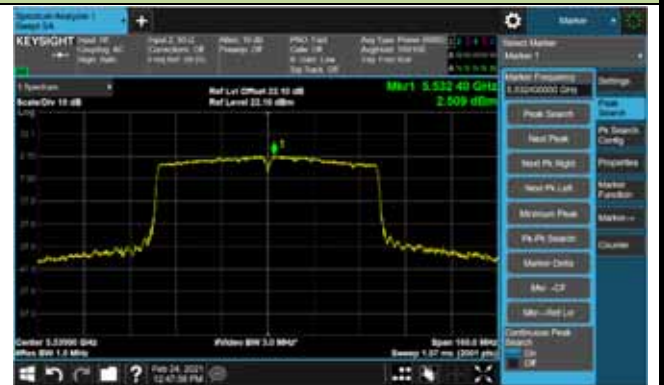

Channel 122 (5610MHz)

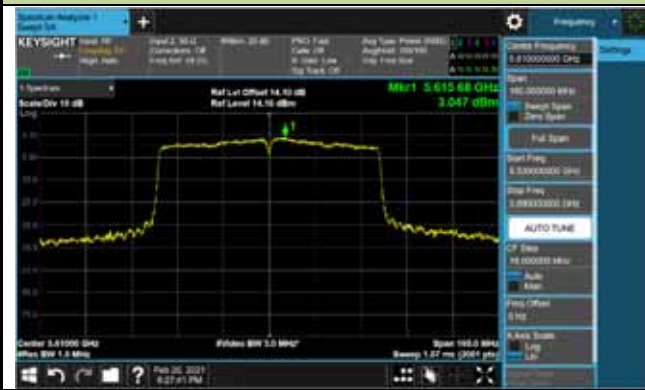

Channel 138(5690MHz)

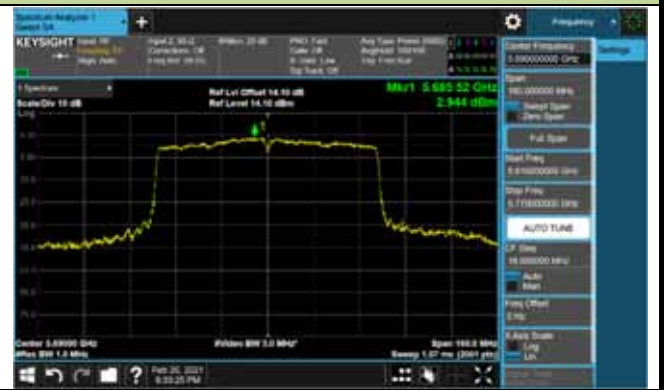

802.11n-HT20 Power Spectral Density –Beamforming Mode Ant 1

Channel 52 (5260MHz)



Channel 60 (5300MHz)

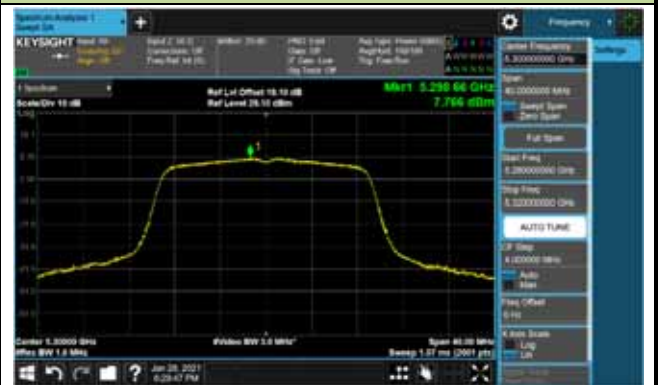

Channel 64 (5320MHz)



Channel 100 (5500MHz)

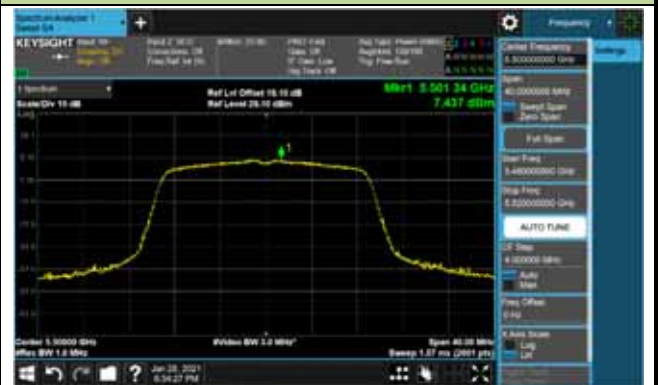

Channel 116 (5580MHz)



Channel 140 (5700MHz)

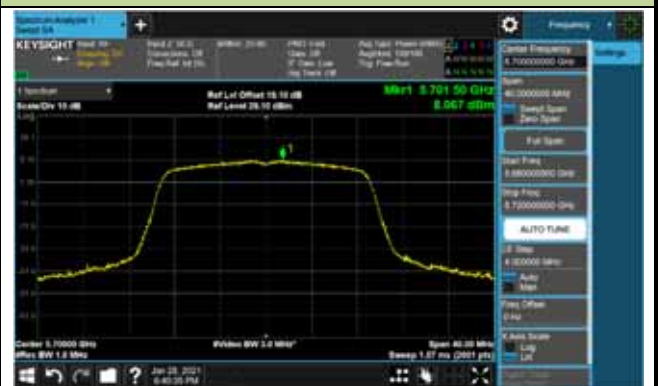

Channel 144 (5720MHz)

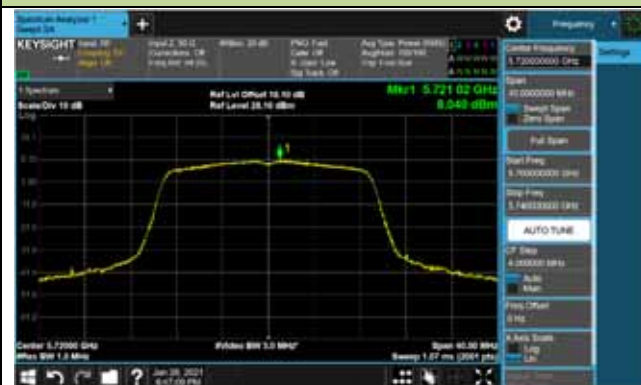

802.11n-HT40 Power Spectral Density –Beamforming Mode Ant 1

Channel 54 (5270MHz)

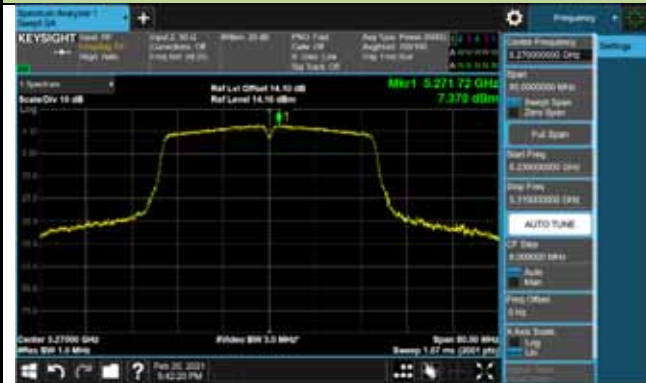

Channel 62 (5310MHz)

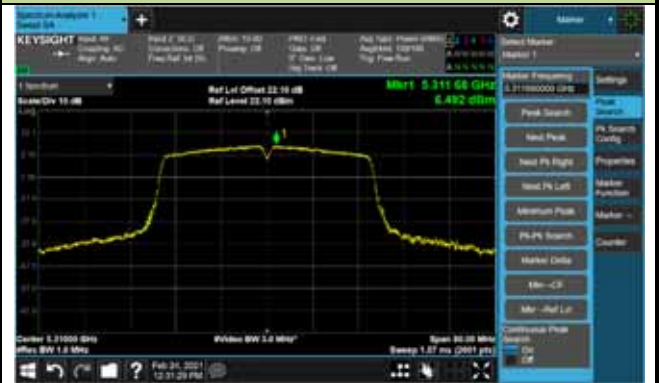

Channel 102 (5510MHz)

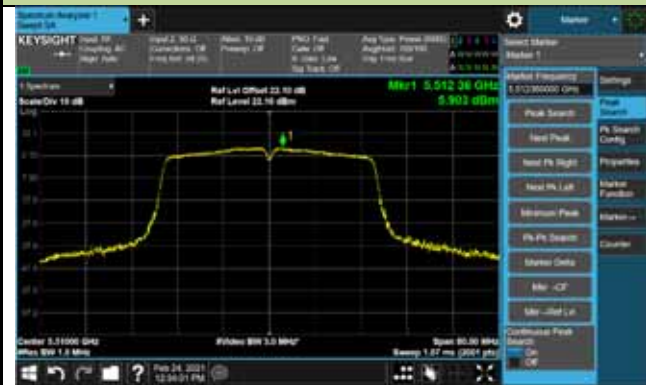

Channel 110 (5550MHz)

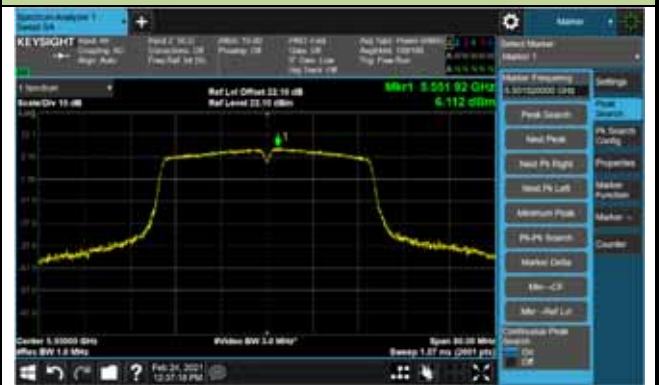

Channel 134 (5670MHz)



Channel 142 (5710MHz)



802.11ac-VHT20 Power Spectral Density –Beamforming Mode Ant 1

Channel 52 (5260MHz)



Channel 60 (5300MHz)

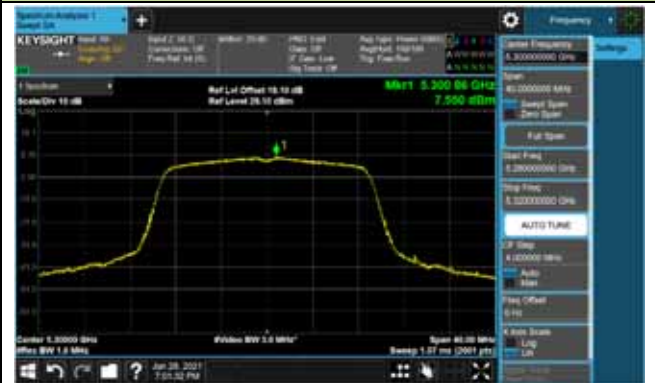

Channel 64 (5320MHz)



Channel 100 (5500MHz)

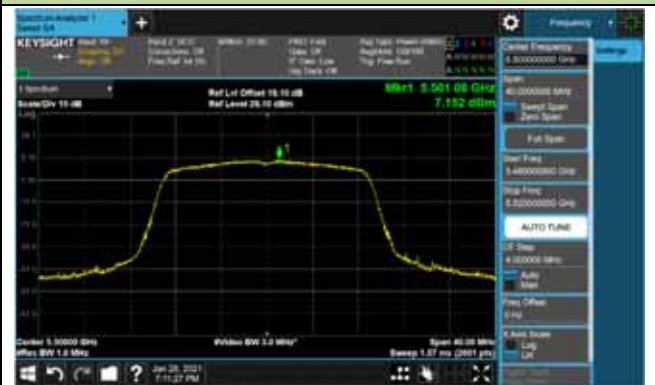

Channel 116 (5580MHz)

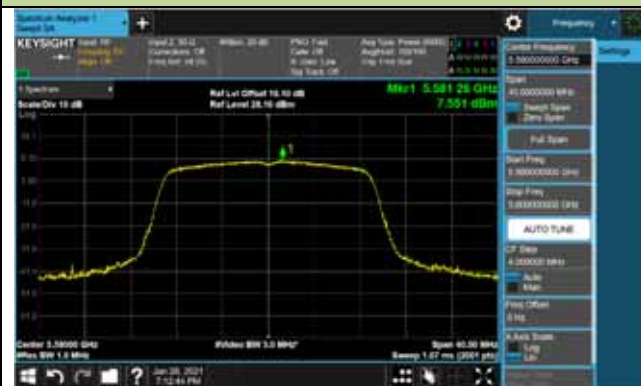

Channel 140 (5700MHz)

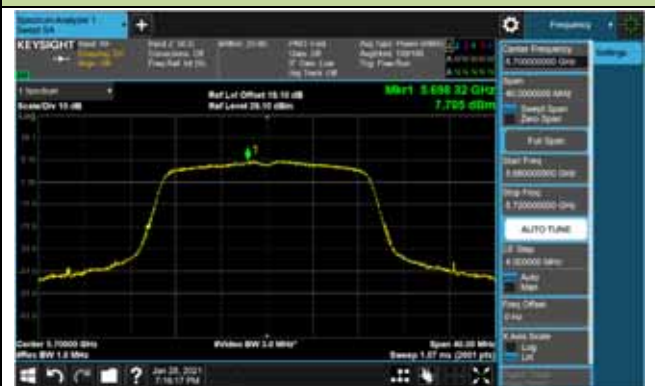

Channel 144 (5720MHz)

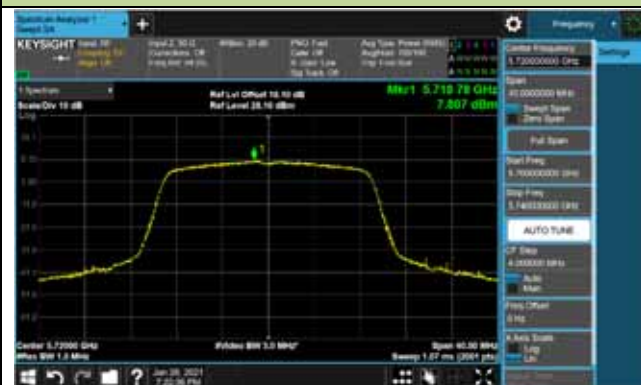

802.11ac-VHT40 Power Spectral Density –Beamforming Mode Ant 1

Channel 54 (5270MHz)

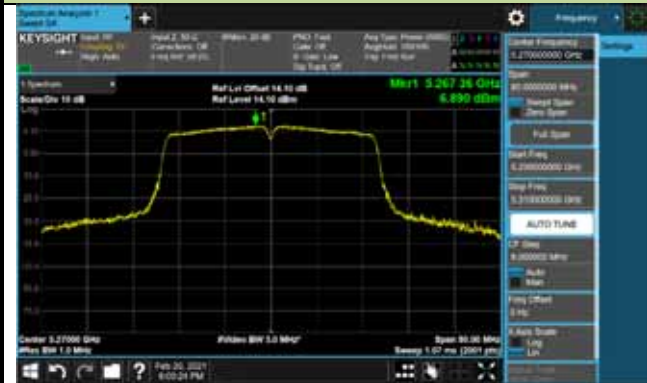

Channel 62 (5310MHz)

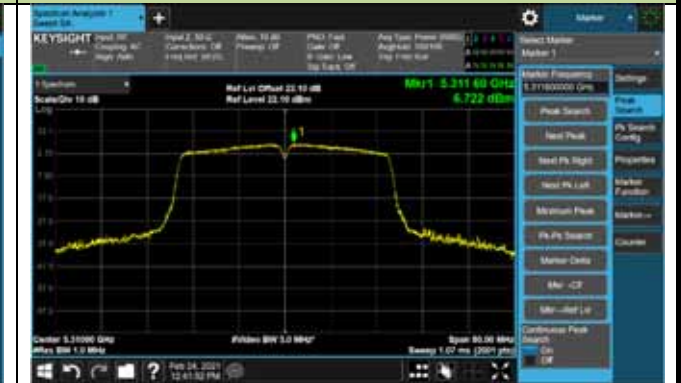

Channel 102 (5510MHz)



Channel 110 (5550MHz)



Channel 134 (5670MHz)



Channel 142 (5710MHz)

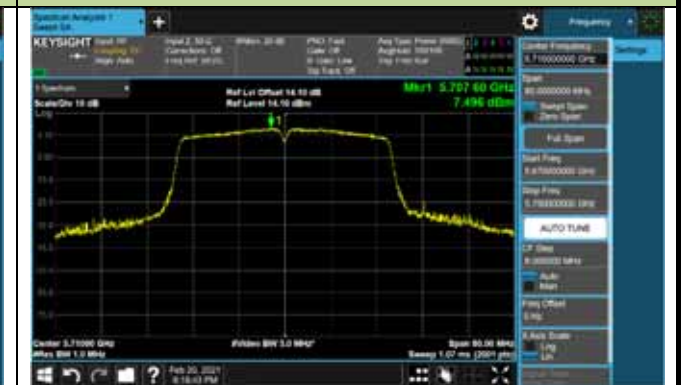

802.11ac-VHT80 Power Spectral Density –Beamforming Mode Ant 1

Channel 58 (5290MHz)



Channel 106 (5530MHz)

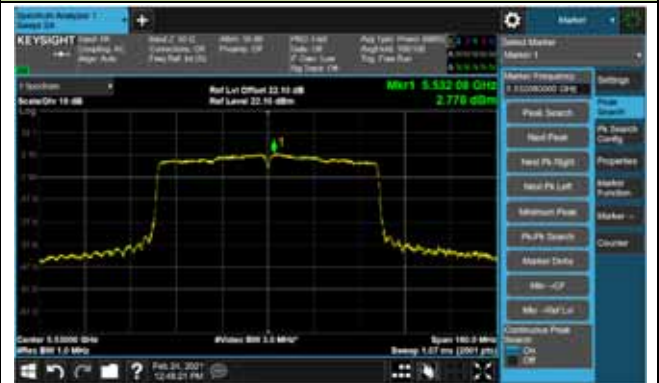

Channel 122 (5610MHz)



Channel 138(5690MHz)



6.6. Frequency Stability Measurement

6.6.1. Test Limit

Manufactures of U-NII devices are responsible for ensuring frequency stability such that an emission is maintained within the band of operation under all conditions of normal operation as specified in the user's manual.

6.6.2. Test Procedure Used

Frequency Stability Under Temperature Variations:

The equipment under test was connected to an external AC or DC power supply and input rated voltage. RF output was connected to a frequency counter or spectrum analyzer via feed through attenuators. The EUT was placed inside the temperature chamber. Set the spectrum analyzer RBW low enough to obtain the desired frequency resolution and measure EUT 20°C operating frequency as reference frequency. Turn EUT off and set the chamber temperature to highest. After the temperature stabilized for approximately 30 minutes recorded the frequency. Repeat step measure with 10°C decreased per stage until the lowest temperature reached.

Frequency Stability Under Voltage Variations:

Set chamber temperature to 20°C. Use a variable AC power supply / DC power source to power the EUT and set the voltage to rated voltage. Set the spectrum analyzer RBW low enough to obtain the desired frequency resolution and recorded the frequency.

Reduce the input voltage to specify extreme voltage variation ($\pm 15\%$) and endpoint, record the maximum frequency change. For hand-carried battery-powered equipment, primary supply voltage is reduced to the battery operating end point which shall be specified by the manufacturer.

6.6.3. Test Setup

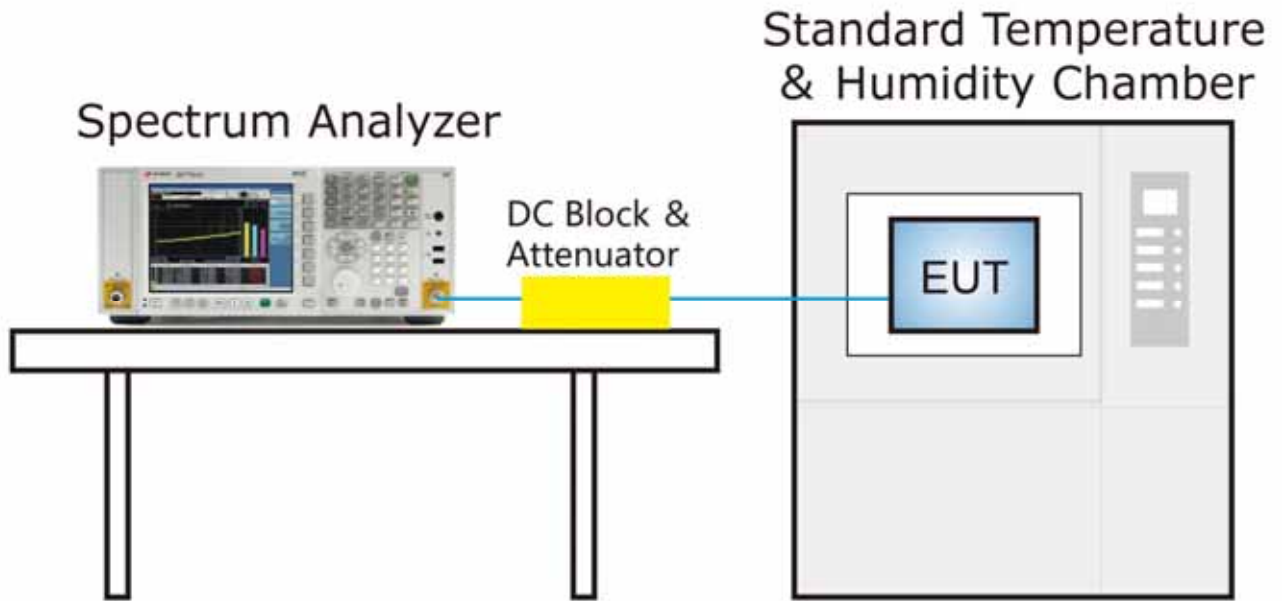

6.6.4. Test Result

Test Site	SIP-SR5	Test Engineer	Chase Zhu
Test Date	2021/03/15	Test Mode	5260MHz (Carrier Mode)

Voltage (%)	Power (V _{AC})	Temp (°C)	Frequency Tolerance (ppm)			
			0 minutes	2 minutes	5 minutes	10 minutes
100%	120	- 30	6.98	7.08	7.05	7.00
		- 20	4.38	3.87	3.63	3.53
		- 10	3.07	2.42	1.76	1.44
		0	0.97	0.23	-0.35	-0.63
		+ 10	-1.23	-2.51	-3.06	-3.51
		+ 20	-4.89	-6.24	-6.59	-6.90
		+ 30	-7.53	-7.89	-8.15	-8.28
		+ 40	-8.04	-8.45	-8.74	-8.81
		+ 50	-8.57	-8.82	-8.86	-8.88
115%	138	+ 20	0.09	-0.84	-1.59	-2.16
85%	102	+ 20	0.04	-1.00	-1.55	-2.09

Note: Frequency Tolerance (ppm) = {[Measured Frequency (MHz) - Declared Frequency (MHz)] / Declared Frequency (MHz)} * 10⁶.

6.7. Radiated Spurious Emission Measurement

6.7.1. Test Limit

All out of band emissions appearing in a restricted band as specified in Section 15.205 of the Title 47 CFR must not exceed the limits shown in Table per Section 15.209.

FCC Part 15 Subpart C Paragraph 15.209		
Frequency (MHz)	Field Strength ($\mu\text{V}/\text{m}$)	Measured Distance (m)
0.009 - 0.490	2400/F (kHz)	300
0.490 - 1.705	24000/F (kHz)	30
1.705 - 30	30	30
30 - 88	100	3
88 - 216	150	3
216 - 960	200	3
Above 960	500	3

6.7.2. Test Procedure Used

KDB 789033 D02v02r01- Section G

6.7.3. Test Setting

Table 1 - RBW as a function of frequency

Frequency	RBW
9 ~ 150 kHz	200 ~ 300 Hz
0.15 ~ 30 MHz	9 ~ 10 kHz
30 ~ 1000 MHz	100 ~ 120 kHz
> 1000 MHz	1 MHz

Quasi-Peak Measurements below 1GHz

1. Analyzer center frequency was set to the frequency of the radiated spurious emission of interest
2. Span was set greater than 1MHz
3. RBW = as specified in Table 1
4. Detector = CISPR quasi-peak
5. Sweep time = auto couple
6. Trace was allowed to stabilize

Peak Measurements above 1GHz

1. Analyzer center frequency was set to the frequency of the radiated spurious emission of interest
2. RBW = 1MHz
3. VBW = 3MHz
4. Detector = peak
5. Sweep time = auto couple
6. Trace mode = max hold
7. Trace was allowed to stabilize

Average Measurements above 1GHz (Method VB)

1. Analyzer center frequency was set to the frequency of the radiated spurious emission of interest
2. RBW = 1MHz
3. VBW; If the EUT is configured to transmit with duty cycle $\geq 98\%$, set VBW = 10Hz
If the EUT duty cycle is $< 98\%$, set VBW $\geq 1/T$. T is the minimum transmission duration
4. Detector = Peak
5. Sweep time = auto
6. Trace mode = max hold
7. Trace was allowed to stabilize

6.7.4. Test Setup

Below 1GHz Test Setup:

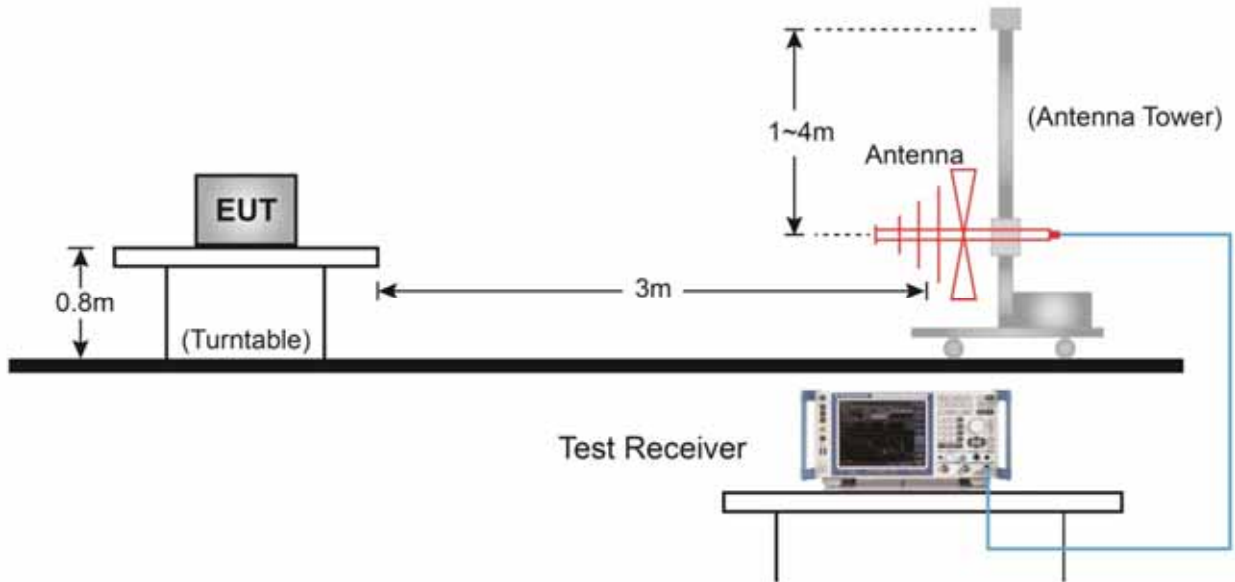

Above 1GHz Test Setup:

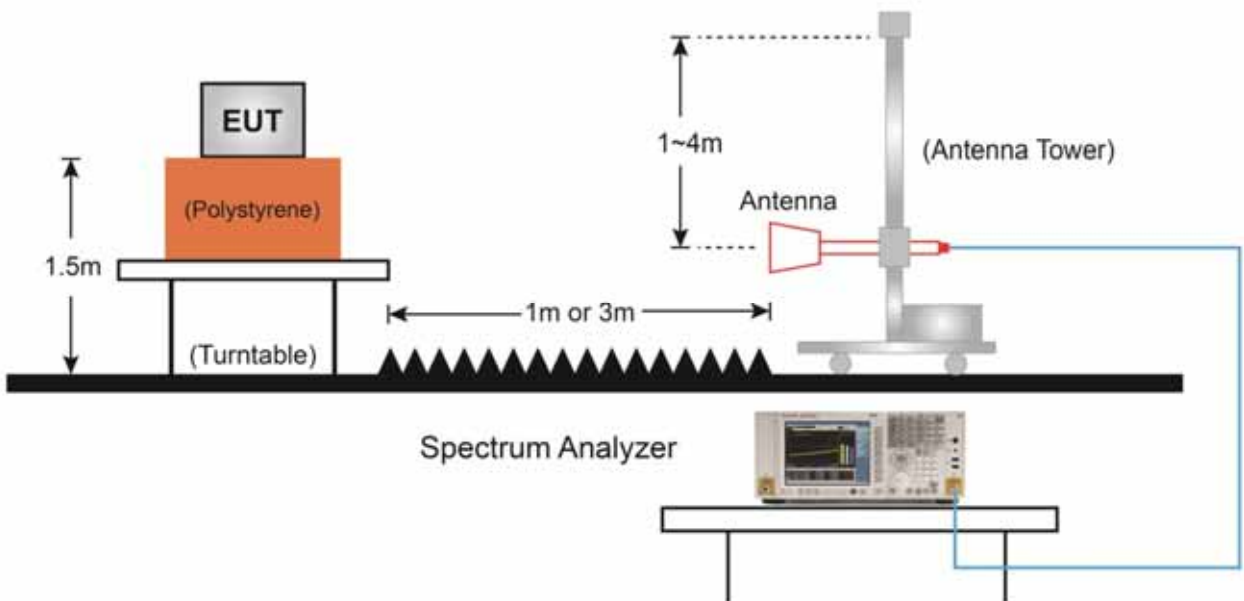

6.7.5. Test Result

Test Site	SIP-AC1	Test Engineer	Stephen Dong
Test Date	2021/02/19	Test Channel	52
Test Mode	802.11a(CDD Mode)		
Remark	1. Average measurement was not performed if peak level lower than average limit. 2. Other frequency was 20dB below limit line within 1-18GHz, there is not show in the report.		

Mark	Frequency (MHz)	Reading Level (dBμV)	Factor (dB)	Measure Level (dBμV/m)	Limit (dBμV/m)	Margin (dB)	Detector	Polarization
	11378.5	50.2	-3.5	46.7	74.0	-27.3	Peak	Horizontal
	12407.0	50.1	-2.1	48.0	74.0	-26.0	Peak	Horizontal
*	14770.0	47.5	1.7	49.2	68.2	-19.0	Peak	Horizontal
*	16538.0	48.1	4.3	52.4	68.2	-15.8	Peak	Horizontal
	8412.0	53.8	-4.8	49.0	74.0	-25.0	Peak	Vertical
*	10520.0	53.1	-3.4	49.7	68.2	-18.5	Peak	Vertical
	15773.0	48.9	3.2	52.1	74.0	-21.9	Peak	Vertical
*	16767.5	47.7	5.0	52.7	68.2	-15.5	Peak	Vertical

Note 1: "*" is not in restricted band, its limit is -27dBm/MHz. At a distance of 3 meters, the field strength limit in dBμV/m can be determined by adding a "conversion" factor of 95.2dB to the EIRP limit of -27dBm/MHz to obtain the limit for out of band spurious emissions.

Note 2: Measure Level (dBμV/m) = Reading Level (dBμV) + Factor (dB)

Factor (dB) = Cable Loss (dB) + Antenna Factor (dB/m) - Pre_Amplifier Gain (dB)

Test Site	SIP-AC1	Test Engineer	Stephen Dong
Test Date	2021/02/19	Test Channel	60
Test Mode	802.11a(CDD Mode)		
Remark	1. Average measurement was not performed if peak level lower than average limit. 2. Other frequency was 20dB below limit line within 1-18GHz, there is not show in the report.		

Mark	Frequency (MHz)	Reading Level (dBμV)	Factor (dB)	Measure Level (dBμV/m)	Limit (dBμV/m)	Margin (dB)	Detector	Polarization
*	10596.5	54.8	-3.4	51.4	68.2	-16.8	Peak	Horizontal
	12441.0	50.2	-2.8	47.4	74.0	-26.6	Peak	Horizontal
	15892.0	48.6	3.6	52.2	74.0	-21.8	Peak	Horizontal
*	16665.5	46.8	5.1	51.9	68.2	-16.3	Peak	Horizontal
	8480.0	53.9	-4.7	49.2	74.0	-24.8	Peak	Vertical
	10605.0	55.2	-3.4	51.8	74.0	-22.2	Peak	Vertical
*	14404.5	49.3	1.4	50.7	68.2	-17.5	Peak	Vertical
*	16546.5	47.8	4.6	52.4	68.2	-15.8	Peak	Vertical

Note 1: "*" is not in restricted band, its limit is -27dBm/MHz. At a distance of 3 meters, the field strength limit in dBμV/m can be determined by adding a "conversion" factor of 95.2dB to the EIRP limit of -27dBm/MHz to obtain the limit for out of band spurious emissions.

Note 2: Measure Level (dBμV/m) = Reading Level (dBμV) + Factor (dB)

Factor (dB) = Cable Loss (dB) + Antenna Factor (dB/m) - Pre_Amplifier Gain (dB)

Test Site	SIP-AC1	Test Engineer	Stephen Dong
Test Date	2021/02/19	Test Channel	64
Test Mode	802.11a(CDD Mode)		
Remark	1. Average measurement was not performed if peak level lower than average limit. 2. Other frequency was 20dB below limit line within 1-18GHz, there is not show in the report.		

Mark	Frequency (MHz)	Reading Level (dBμV)	Factor (dB)	Measure Level (dBμV/m)	Limit (dBμV/m)	Margin (dB)	Detector	Polarization
	10639.0	54.8	-3.5	51.3	74.0	-22.7	Peak	Horizontal
*	14243.0	48.4	1.2	49.6	68.2	-18.6	Peak	Horizontal
	15960.0	50.5	3.8	54.3	74.0	-19.7	Peak	Horizontal
	15960.0	38.8	3.8	42.6	54.0	-11.4	Average	Horizontal
*	16597.5	47.9	4.7	52.6	68.2	-15.6	Peak	Horizontal
	10639.0	56.7	-3.5	53.2	74.0	-20.8	Peak	Vertical
*	13996.5	48.3	0.4	48.7	68.2	-19.5	Peak	Vertical
*	14583.0	48.1	1.7	49.8	68.2	-18.4	Peak	Vertical
	15960.0	51.0	3.8	54.8	74.0	-19.2	Peak	Vertical

Note 1: "*" is not in restricted band, its limit is -27dBm/MHz. At a distance of 3 meters, the field strength limit in dBμV/m can be determined by adding a "conversion" factor of 95.2dB to the EIRP limit of -27dBm/MHz to obtain the limit for out of band spurious emissions.

Note 2: Measure Level (dBμV/m) = Reading Level (dBμV) + Factor (dB)

Factor (dB) = Cable Loss (dB) + Antenna Factor (dB/m) - Pre_Amplifier Gain (dB)

Test Site	SIP-AC1	Test Engineer	Stephen Dong
Test Date	2021/02/19	Test Channel	100
Test Mode	802.11a(CDD Mode)		
Remark	1. Average measurement was not performed if peak level lower than average limit. 2. Other frequency was 20dB below limit line within 1-18GHz, there is not show in the report.		

Mark	Frequency (MHz)	Reading Level (dB μ V)	Factor (dB)	Measure Level (dB μ V/m)	Limit (dB μ V/m)	Margin (dB)	Detector	Polarization
	10987.5	58.9	-5.3	53.6	74.0	-20.4	Peak	Horizontal
	10987.5	46.0	-5.3	40.7	54.0	-13.3	Average	Horizontal
*	16504.0	49.7	3.6	53.3	68.2	-14.9	Peak	Horizontal
*	17354.0	48.8	4.6	53.4	68.2	-14.8	Peak	Horizontal
	17898.0	47.7	6.2	53.9	74.0	-20.1	Peak	Horizontal
	17898.0	37.3	6.2	43.5	54.0	-10.5	Average	Horizontal
	10996.0	58.3	-5.3	53.0	74.0	-21.0	Peak	Vertical
*	16504.0	53.0	3.6	56.6	68.2	-11.6	Peak	Vertical
*	17337.0	48.5	4.9	53.4	68.2	-14.8	Peak	Vertical
	17881.0	47.6	5.8	53.4	74.0	-20.6	Peak	Vertical
	17881.0	37.9	5.8	43.7	54.0	-10.3	Average	Vertical

Note 1: "*" is not in restricted band, its limit is -27dBm/MHz. At a distance of 3 meters, the field strength limit in dB μ V/m can be determined by adding a "conversion" factor of 95.2dB to the EIRP limit of -27dBm/MHz to obtain the limit for out of band spurious emissions.

Note 2: Measure Level (dB μ V/m) = Reading Level (dB μ V) + Factor (dB)

Factor (dB) = Cable Loss (dB) + Antenna Factor (dB/m) - Pre_Amplifier Gain (dB)

Test Site	SIP-AC1	Test Engineer	Stephen Dong
Test Date	2021/02/19	Test Channel	116
Test Mode	802.11a(CDD Mode)		
Remark	1. Average measurement was not performed if peak level lower than average limit. 2. Other frequency was 20dB below limit line within 1-18GHz, there is not show in the report.		

Mark	Frequency (MHz)	Reading Level (dB μ V)	Factor (dB)	Measure Level (dB μ V/m)	Limit (dB μ V/m)	Margin (dB)	Detector	Polarization
	11157.5	57.2	-5.3	51.9	74.0	-22.1	Peak	Horizontal
*	16716.5	48.2	4.1	52.3	68.2	-15.9	Peak	Horizontal
*	17660.0	48.7	5.0	53.7	68.2	-14.5	Peak	Horizontal
	17889.5	47.6	6.0	53.6	74.0	-20.4	Peak	Horizontal
	17889.5	39.1	6.0	45.1	54.0	-8.9	Average	Horizontal
	11157.5	65.0	-5.3	59.7	74.0	-14.3	Peak	Vertical
	11157.5	44.7	-5.3	39.4	54.0	-14.6	Average	Vertical
*	16733.5	50.7	4.2	54.9	68.2	-13.3	Peak	Vertical
*	17269.0	48.1	4.3	52.4	68.2	-15.8	Peak	Vertical
	17898.0	48.8	6.2	55.0	74.0	-19.0	Peak	Vertical
	17898.0	38.1	6.2	44.3	54.0	-9.7	Average	Vertical

Note 1: "*" is not in restricted band, its limit is -27dBm/MHz. At a distance of 3 meters, the field strength limit in dB μ V/m can be determined by adding a "conversion" factor of 95.2dB to the EIRP limit of -27dBm/MHz to obtain the limit for out of band spurious emissions.

Note 2: Measure Level (dB μ V/m) = Reading Level (dB μ V) + Factor (dB)

Factor (dB) = Cable Loss (dB) + Antenna Factor (dB/m) - Pre_Amplifier Gain (dB)

Test Site	SIP-AC1	Test Engineer	Stephen Dong
Test Date	2021/02/19	Test Channel	140
Test Mode	802.11a(CDD Mode)		
Remark	1. Average measurement was not performed if peak level lower than average limit. 2. Other frequency was 20dB below limit line within 1-18GHz, there is not show in the report.		

Mark	Frequency (MHz)	Reading Level (dBμV)	Factor (dB)	Measure Level (dBμV/m)	Limit (dBμV/m)	Margin (dB)	Detector	Polarization
	11395.5	55.7	-5.0	50.7	74.0	-23.3	Peak	Horizontal
*	16691.0	48.3	3.7	52.0	68.2	-16.2	Peak	Horizontal
*	17099.0	48.8	4.0	52.8	68.2	-15.4	Peak	Horizontal
	17745.0	47.8	5.8	53.6	74.0	-20.4	Peak	Horizontal
	17745.0	37.9	5.8	43.7	54.0	-10.3	Average	Horizontal
	15866.5	49.9	2.5	52.4	74.0	-21.6	Peak	Vertical
*	16793.0	48.3	4.0	52.3	68.2	-15.9	Peak	Vertical
*	17379.5	48.3	5.2	53.5	68.2	-14.7	Peak	Vertical
	17787.5	48.4	5.8	54.2	74.0	-19.8	Peak	Vertical
	17787.5	37.9	5.8	43.7	54.0	-10.3	Average	Vertical

Note 1: "*" is not in restricted band, its limit is -27dBm/MHz. At a distance of 3 meters, the field strength limit in dBμV/m can be determined by adding a "conversion" factor of 95.2dB to the EIRP limit of -27dBm/MHz to obtain the limit for out of band spurious emissions.

Note 2: Measure Level (dBμV/m) = Reading Level (dBμV) + Factor (dB)

Factor (dB) = Cable Loss (dB) + Antenna Factor (dB/m) - Pre_Amplifier Gain (dB)

Test Site	SIP-AC1	Test Engineer	Stephen Dong
Test Date	2021/02/19	Test Channel	144
Test Mode	802.11a(CDD Mode)		
Remark	1. Average measurement was not performed if peak level lower than average limit. 2. Other frequency was 20dB below limit line within 1-18GHz, there is not show in the report.		

Mark	Frequency (MHz)	Reading Level (dBμV)	Factor (dB)	Measure Level (dBμV/m)	Limit (dBμV/m)	Margin (dB)	Detector	Polarization
	16155.5	48.8	2.6	51.4	74.0	-22.6	Peak	Horizontal
*	16852.5	47.8	4.2	52.0	68.2	-16.2	Peak	Horizontal
*	17668.5	48.0	5.1	53.1	68.2	-15.1	Peak	Horizontal
	17881.0	47.4	5.8	53.2	74.0	-20.8	Peak	Horizontal
	17881.0	37.1	5.8	42.9	54.0	-11.1	Average	Horizontal
	15450.0	48.8	2.0	50.8	74.0	-23.2	Peak	Vertical
*	16521.0	48.1	3.3	51.4	68.2	-16.8	Peak	Vertical
*	17150.0	48.8	4.2	53.0	68.2	-15.2	Peak	Vertical
	17753.5	47.4	5.5	52.9	74.0	-21.1	Peak	Vertical

Note 1: "*" is not in restricted band, its limit is -27dBm/MHz. At a distance of 3 meters, the field strength limit in dBμV/m can be determined by adding a "conversion" factor of 95.2dB to the EIRP limit of -27dBm/MHz to obtain the limit for out of band spurious emissions.

Note 2: Measure Level (dBμV/m) = Reading Level (dBμV) + Factor (dB)

Factor (dB) = Cable Loss (dB) + Antenna Factor (dB/m) - Pre_Amplifier Gain (dB)

Test Site	SIP-AC1	Test Engineer	Stephen Dong
Test Date	2021/02/19	Test Channel	52
Test Mode	802.11n-HT20(CDD Mode)		
Remark	1. Average measurement was not performed if peak level lower than average limit. 2. Other frequency was 20dB below limit line within 1-18GHz, there is not show in the report.		

Mark	Frequency (MHz)	Reading Level (dB μ V)	Factor (dB)	Measure Level (dB μ V/m)	Limit (dB μ V/m)	Margin (dB)	Detector	Polarization
	15781.5	50.8	2.5	53.3	74.0	-20.7	Peak	Horizontal
	15781.5	42.2	2.5	44.7	54.0	-9.3	Average	Horizontal
*	16682.5	47.9	3.7	51.6	68.2	-16.6	Peak	Horizontal
*	17286.0	48.0	4.9	52.9	68.2	-15.3	Peak	Horizontal
	17906.5	47.2	6.0	53.2	74.0	-20.8	Peak	Horizontal
	17906.5	39.1	6.0	45.1	54.0	-8.9	Average	Horizontal
*	10520.0	57.7	-5.5	52.2	68.2	-16.0	Peak	Vertical
	15773.0	52.0	2.8	54.8	74.0	-19.2	Peak	Vertical
	15773.0	45.1	2.8	47.9	54.0	-6.1	Average	Vertical
*	17337.0	48.6	4.9	53.5	68.2	-14.7	Peak	Vertical
	17949.0	47.9	5.9	53.8	74.0	-20.2	Peak	Vertical
	17949.0	38.7	5.9	44.6	54.0	-9.4	Average	Vertical

Note 1: "*" is not in restricted band, its limit is -27dBm/MHz. At a distance of 3 meters, the field strength limit in dB μ V/m can be determined by adding a "conversion" factor of 95.2dB to the EIRP limit of -27dBm/MHz to obtain the limit for out of band spurious emissions.

Note 2: Measure Level (dB μ V/m) = Reading Level (dB μ V) + Factor (dB)

Factor (dB) = Cable Loss (dB) + Antenna Factor (dB/m) - Pre_Amplifier Gain (dB)

Test Site	SIP-AC1	Test Engineer	Stephen Dong
Test Date	2021/02/19	Test Channel	60
Test Mode	802.11n-HT20(CDD Mode)		
Remark	1. Average measurement was not performed if peak level lower than average limit. 2. Other frequency was 20dB below limit line within 1-18GHz, there is not show in the report.		

Mark	Frequency (MHz)	Reading Level (dBμV)	Factor (dB)	Measure Level (dBμV/m)	Limit (dBμV/m)	Margin (dB)	Detector	Polarization
	15892.0	51.8	2.1	53.9	74.0	-20.1	Peak	Horizontal
	15892.0	43.7	2.1	45.8	54.0	-8.2	Average	Horizontal
*	16784.5	48.2	4.1	52.3	68.2	-15.9	Peak	Horizontal
*	17396.5	47.5	5.2	52.7	68.2	-15.5	Peak	Horizontal
	17991.5	47.8	5.9	53.7	74.0	-20.3	Peak	Horizontal
	17991.5	38.9	5.9	44.8	54.0	-9.2	Average	Horizontal
*	10596.5	57.5	-5.6	51.9	68.2	-16.3	Peak	Vertical
	15892.0	53.0	2.1	55.1	74.0	-18.9	Peak	Vertical
	15892.0	45.0	2.1	47.1	54.0	-6.9	Average	Vertical
*	17413.5	48.9	5.0	53.9	68.2	-14.3	Peak	Vertical
	17915.0	48.2	5.9	54.1	74.0	-19.9	Peak	Vertical
	17915.0	37.6	5.9	43.5	54.0	-10.5	Average	Vertical

Note 1: "*" is not in restricted band, its limit is -27dBm/MHz. At a distance of 3 meters, the field strength limit in dBμV/m can be determined by adding a "conversion" factor of 95.2dB to the EIRP limit of -27dBm/MHz to obtain the limit for out of band spurious emissions.

Note 2: Measure Level (dBμV/m) = Reading Level (dBμV) + Factor (dB)

Factor (dB) = Cable Loss (dB) + Antenna Factor (dB/m) - Pre_Amplifier Gain (dB)

Test Site	SIP-AC1	Test Engineer	Stephen Dong
Test Date	2021/02/19	Test Channel	64
Test Mode	802.11n-HT20(CDD Mode)		
Remark	1. Average measurement was not performed if peak level lower than average limit. 2. Other frequency was 20dB below limit line within 1-18GHz, there is not show in the report.		

Mark	Frequency (MHz)	Reading Level (dBμV)	Factor (dB)	Measure Level (dBμV/m)	Limit (dBμV/m)	Margin (dB)	Detector	Polarization
	10639.0	57.8	-5.4	52.4	74.0	-21.6	Peak	Horizontal
*	16844.0	47.8	4.2	52.0	68.2	-16.2	Peak	Horizontal
*	17388.0	47.3	5.3	52.6	68.2	-15.6	Peak	Horizontal
	17915.0	47.7	5.9	53.6	74.0	-20.4	Peak	Horizontal
	17915.0	38.9	5.9	44.8	54.0	-9.2	Average	Horizontal
	15960.0	52.3	2.3	54.6	74.0	-19.4	Peak	Vertical
	15960.0	44.9	2.3	47.2	54.0	-6.8	Average	Vertical
*	16725.0	48.0	4.3	52.3	68.2	-15.9	Peak	Vertical
*	17286.0	47.9	4.9	52.8	68.2	-15.4	Peak	Vertical
	17855.5	47.6	5.8	53.4	74.0	-20.6	Peak	Vertical
	17855.5	38.0	5.8	43.8	54.0	-10.2	Average	Vertical

Note 1: "*" is not in restricted band, its limit is -27dBm/MHz. At a distance of 3 meters, the field strength limit in dBμV/m can be determined by adding a "conversion" factor of 95.2dB to the EIRP limit of -27dBm/MHz to obtain the limit for out of band spurious emissions.

Note 2: Measure Level (dBμV/m) = Reading Level (dBμV) + Factor (dB)

Factor (dB) = Cable Loss (dB) + Antenna Factor (dB/m) - Pre_Amplifier Gain (dB)

Test Site	SIP-AC1	Test Engineer	Stephen Dong
Test Date	2021/02/19	Test Channel	100
Test Mode	802.11n-HT20(CDD Mode)		
Remark	1. Average measurement was not performed if peak level lower than average limit. 2. Other frequency was 20dB below limit line within 1-18GHz, there is not show in the report.		

Mark	Frequency (MHz)	Reading Level (dB μ V)	Factor (dB)	Measure Level (dB μ V/m)	Limit (dB μ V/m)	Margin (dB)	Detector	Polarization
	10996.0	59.9	-5.3	54.6	74.0	-19.4	Peak	Horizontal
	10996.0	45.6	-5.3	40.3	54.0	-13.7	Average	Horizontal
*	16504.0	50.5	3.6	54.1	68.2	-14.1	Peak	Horizontal
*	17345.5	48.5	4.7	53.2	68.2	-15.0	Peak	Horizontal
	17796.0	47.3	6.1	53.4	74.0	-20.6	Peak	Horizontal
	17796.0	39.4	6.1	45.5	54.0	-8.5	Average	Horizontal
	11004.5	56.9	-5.2	51.7	74.0	-22.3	Peak	Vertical
*	16504.0	50.5	3.6	54.1	68.2	-14.1	Peak	Vertical
*	17286.0	47.7	4.9	52.6	68.2	-15.6	Peak	Vertical
	17991.5	46.9	5.9	52.8	74.0	-21.2	Peak	Vertical

Note 1: "*" is not in restricted band, its limit is -27dBm/MHz. At a distance of 3 meters, the field strength limit in dB μ V/m can be determined by adding a "conversion" factor of 95.2dB to the EIRP limit of -27dBm/MHz to obtain the limit for out of band spurious emissions.

Note 2: Measure Level (dB μ V/m) = Reading Level (dB μ V) + Factor (dB)

Factor (dB) = Cable Loss (dB) + Antenna Factor (dB/m) - Pre_Amplifier Gain (dB)

Test Site	SIP-AC1	Test Engineer	Stephen Dong
Test Date	2021/02/19	Test Channel	116
Test Mode	802.11n-HT20(CDD Mode)		
Remark	1. Average measurement was not performed if peak level lower than average limit. 2. Other frequency was 20dB below limit line within 1-18GHz, there is not show in the report.		

Mark	Frequency (MHz)	Reading Level (dBμV)	Factor (dB)	Measure Level (dBμV/m)	Limit (dBμV/m)	Margin (dB)	Detector	Polarization
	11157.5	60.0	-5.3	54.7	74.0	-19.3	Peak	Horizontal
	11157.5	47.0	-5.3	41.7	54.0	-12.3	Average	Horizontal
*	16742.0	48.5	4.2	52.7	68.2	-15.5	Peak	Horizontal
*	17286.0	47.9	4.9	52.8	68.2	-15.4	Peak	Horizontal
	17796.0	47.5	6.1	53.6	74.0	-20.4	Peak	Horizontal
	17796.0	38.0	6.1	44.1	54.0	-9.9	Average	Horizontal
	11166.0	60.1	-5.4	54.7	74.0	-19.3	Peak	Vertical
	11166.0	45.7	-5.4	40.3	54.0	-13.7	Average	Vertical
*	16742.0	49.8	4.2	54.0	68.2	-14.2	Peak	Vertical
*	17439.0	47.1	5.1	52.2	68.2	-16.0	Peak	Vertical
	17881.0	47.9	5.8	53.7	74.0	-20.3	Peak	Vertical
	17881.0	39.7	5.8	45.5	54.0	-8.5	Average	Vertical

Note 1: "*" is not in restricted band, its limit is -27dBm/MHz. At a distance of 3 meters, the field strength limit in dBμV/m can be determined by adding a "conversion" factor of 95.2dB to the EIRP limit of -27dBm/MHz to obtain the limit for out of band spurious emissions.

Note 2: Measure Level (dBμV/m) = Reading Level (dBμV) + Factor (dB)

Factor (dB) = Cable Loss (dB) + Antenna Factor (dB/m) - Pre_Amplifier Gain (dB)

Test Site	SIP-AC1	Test Engineer	Stephen Dong
Test Date	2021/02/19	Test Channel	140
Test Mode	802.11n-HT20(CDD Mode)		
Remark	1. Average measurement was not performed if peak level lower than average limit. 2. Other frequency was 20dB below limit line within 1-18GHz, there is not show in the report.		

Mark	Frequency (MHz)	Reading Level (dBμV)	Factor (dB)	Measure Level (dBμV/m)	Limit (dBμV/m)	Margin (dB)	Detector	Polarization
	16079.0	48.2	2.9	51.1	74.0	-22.9	Peak	Horizontal
*	17099.0	50.5	4.0	54.5	68.2	-13.7	Peak	Horizontal
*	17541.0	47.5	4.8	52.3	68.2	-15.9	Peak	Horizontal
	17906.5	47.6	6.0	53.6	74.0	-20.4	Peak	Horizontal
	17906.5	38.7	6.0	44.7	54.0	-9.3	Average	Horizontal
	11404.0	57.0	-5.1	51.9	74.0	-22.1	Peak	Vertical
*	16827.0	48.0	4.3	52.3	68.2	-15.9	Peak	Vertical
*	17354.0	48.4	4.6	53.0	68.2	-15.2	Peak	Vertical
	17898.0	47.5	6.2	53.7	74.0	-20.3	Peak	Vertical
	17898.0	39.4	6.2	45.6	54.0	-8.4	Average	Vertical

Note 1: "*" is not in restricted band, its limit is -27dBm/MHz. At a distance of 3 meters, the field strength limit in dBμV/m can be determined by adding a "conversion" factor of 95.2dB to the EIRP limit of -27dBm/MHz to obtain the limit for out of band spurious emissions.

Note 2: Measure Level (dBμV/m) = Reading Level (dBμV) + Factor (dB)

Factor (dB) = Cable Loss (dB) + Antenna Factor (dB/m) - Pre_Amplifier Gain (dB)

Test Site	SIP-AC1	Test Engineer	Stephen Dong
Test Date	2021/02/19	Test Channel	144
Test Mode	802.11n-HT20(CDD Mode)		
Remark	1. Average measurement was not performed if peak level lower than average limit. 2. Other frequency was 20dB below limit line within 1-18GHz, there is not show in the report.		

Mark	Frequency (MHz)	Reading Level (dB μ V)	Factor (dB)	Measure Level (dB μ V/m)	Limit (dB μ V/m)	Margin (dB)	Detector	Polarization
	16070.5	48.1	2.7	50.8	74.0	-23.2	Peak	Horizontal
*	16886.5	49.3	4.0	53.3	68.2	-14.9	Peak	Horizontal
*	17167.0	50.5	4.2	54.7	68.2	-13.5	Peak	Horizontal
	17932.0	47.5	5.9	53.4	74.0	-20.6	Peak	Horizontal
	17932.0	39.7	5.9	45.6	54.0	-8.4	Average	Horizontal
	15764.5	49.1	2.7	51.8	74.0	-22.2	Peak	Vertical
*	16929.0	49.0	4.0	53.0	68.2	-15.2	Peak	Vertical
*	17294.5	48.3	4.9	53.2	68.2	-15.0	Peak	Vertical
	17719.5	48.6	5.2	53.8	74.0	-20.2	Peak	Vertical
	17719.5	39.9	5.2	45.1	54.0	-8.9	Average	Vertical

Note 1: "*" is not in restricted band, its limit is -27dBm/MHz. At a distance of 3 meters, the field strength limit in dB μ V/m can be determined by adding a "conversion" factor of 95.2dB to the EIRP limit of -27dBm/MHz to obtain the limit for out of band spurious emissions.

Note 2: Measure Level (dB μ V/m) = Reading Level (dB μ V) + Factor (dB)

Factor (dB) = Cable Loss (dB) + Antenna Factor (dB/m) - Pre_Amplifier Gain (dB)

Test Site	SIP-AC1	Test Engineer	Stephen Dong
Test Date	2021/02/19	Test Channel	54
Test Mode	802.11n-HT40(CDD Mode)		
Remark	1. Average measurement was not performed if peak level lower than average limit. 2. Other frequency was 20dB below limit line within 1-18GHz, there is not show in the report.		

Mark	Frequency (MHz)	Reading Level (dB μ V)	Factor (dB)	Measure Level (dB μ V/m)	Limit (dB μ V/m)	Margin (dB)	Detector	Polarization
	15798.5	51.6	2.1	53.7	74.0	-20.3	Peak	Horizontal
	15798.5	42.4	2.1	44.5	54.0	-9.5	Average	Horizontal
*	16818.5	48.4	4.1	52.5	68.2	-15.7	Peak	Horizontal
*	17362.5	47.8	4.9	52.7	68.2	-15.5	Peak	Horizontal
	17906.5	47.4	6.0	53.4	74.0	-20.6	Peak	Horizontal
	17906.5	39.7	6.0	45.7	54.0	-8.3	Average	Horizontal
*	10545.5	57.6	-5.6	52.0	68.2	-16.2	Peak	Vertical
	15807.0	52.8	2.0	54.8	74.0	-19.2	Peak	Vertical
	15807.0	40.8	2.0	42.8	54.0	-11.2	Average	Vertical
*	17294.5	47.7	4.9	52.6	68.2	-15.6	Peak	Vertical
	17991.5	47.6	5.9	53.5	74.0	-20.5	Peak	Vertical
	17991.5	39.0	5.9	44.9	54.0	-9.1	Average	Vertical

Note 1: "*" is not in restricted band, its limit is -27dBm/MHz. At a distance of 3 meters, the field strength limit in dB μ V/m can be determined by adding a "conversion" factor of 95.2dB to the EIRP limit of -27dBm/MHz to obtain the limit for out of band spurious emissions.

Note 2: Measure Level (dB μ V/m) = Reading Level (dB μ V) + Factor (dB)

Factor (dB) = Cable Loss (dB) + Antenna Factor (dB/m) - Pre_Amplifier Gain (dB)

Test Site	SIP-AC1	Test Engineer	Stephen Dong
Test Date	2021/02/19	Test Channel	62
Test Mode	802.11n-HT40(CDD Mode)		
Remark	1. Average measurement was not performed if peak level lower than average limit. 2. Other frequency was 20dB below limit line within 1-18GHz, there is not show in the report.		

Mark	Frequency (MHz)	Reading Level (dB μ V)	Factor (dB)	Measure Level (dB μ V/m)	Limit (dB μ V/m)	Margin (dB)	Detector	Polarization
	15892.0	48.8	2.1	50.9	74.0	-23.1	Peak	Horizontal
*	16495.5	48.7	3.5	52.2	68.2	-16.0	Peak	Horizontal
*	17388.0	47.0	5.3	52.3	68.2	-15.9	Peak	Horizontal
	17906.5	47.3	6.0	53.3	74.0	-20.7	Peak	Horizontal
	17906.5	39.4	6.0	45.4	54.0	-8.6	Average	Horizontal
	15858.0	48.0	2.7	50.7	74.0	-23.3	Peak	Vertical
*	16504.0	48.7	3.6	52.3	68.2	-15.9	Peak	Vertical
*	17371.0	47.0	5.2	52.2	68.2	-16.0	Peak	Vertical
	17745.0	47.8	5.8	53.6	74.0	-20.4	Peak	Vertical
	17745.0	40.1	5.8	45.9	54.0	-8.1	Average	Vertical

Note 1: "*" is not in restricted band, its limit is -27dBm/MHz. At a distance of 3 meters, the field strength limit in dB μ V/m can be determined by adding a "conversion" factor of 95.2dB to the EIRP limit of -27dBm/MHz to obtain the limit for out of band spurious emissions.

Note 2: Measure Level (dB μ V/m) = Reading Level (dB μ V) + Factor (dB)

Factor (dB) = Cable Loss (dB) + Antenna Factor (dB/m) - Pre_Amplifier Gain (dB)

Test Site	SIP-AC1	Test Engineer	Stephen Dong
Test Date	2021/02/19	Test Channel	102
Test Mode	802.11n-HT40(CDD Mode)		
Remark	1. Average measurement was not performed if peak level lower than average limit. 2. Other frequency was 20dB below limit line within 1-18GHz, there is not show in the report.		

Mark	Frequency (MHz)	Reading Level (dBμV)	Factor (dB)	Measure Level (dBμV/m)	Limit (dBμV/m)	Margin (dB)	Detector	Polarization
	11021.5	58.9	-5.2	53.7	74.0	-20.3	Peak	Horizontal
	11021.5	41.4	-5.2	36.2	54.0	-17.8	Average	Horizontal
*	16529.5	49.8	3.2	53.0	68.2	-15.2	Peak	Horizontal
*	17677.0	48.8	5.2	54.0	68.2	-14.2	Peak	Horizontal
	17881.0	47.5	5.8	53.3	74.0	-20.7	Peak	Horizontal
	17881.0	39.5	5.8	45.3	54.0	-8.7	Average	Horizontal
	15968.5	48.8	2.3	51.1	74.0	-22.9	Peak	Vertical
*	16512.5	51.1	3.4	54.5	68.2	-13.7	Peak	Vertical
*	17269.0	48.9	4.3	53.2	68.2	-15.0	Peak	Vertical
	17821.5	48.1	5.7	53.8	74.0	-20.2	Peak	Vertical
	17821.5	39.2	5.7	44.9	54.0	-9.1	Average	Vertical

Note 1: "*" is not in restricted band, its limit is -27dBm/MHz. At a distance of 3 meters, the field strength limit in dBμV/m can be determined by adding a "conversion" factor of 95.2dB to the EIRP limit of -27dBm/MHz to obtain the limit for out of band spurious emissions.

Note 2: Measure Level (dBμV/m) = Reading Level (dBμV) + Factor (dB)

Factor (dB) = Cable Loss (dB) + Antenna Factor (dB/m) - Pre_Amplifier Gain (dB)

Test Site	SIP-AC1	Test Engineer	Stephen Dong
Test Date	2021/02/19	Test Channel	110
Test Mode	802.11n-HT40(CDD Mode)		
Remark	1. Average measurement was not performed if peak level lower than average limit. 2. Other frequency was 20dB below limit line within 1-18GHz, there is not show in the report.		

Mark	Frequency (MHz)	Reading Level (dB μ V)	Factor (dB)	Measure Level (dB μ V/m)	Limit (dB μ V/m)	Margin (dB)	Detector	Polarization
	11089.5	60.4	-5.3	55.1	74.0	-18.9	Peak	Horizontal
	11089.5	45.4	-5.3	40.1	54.0	-13.9	Average	Horizontal
*	14982.5	49.2	0.7	49.9	68.2	-18.3	Peak	Horizontal
*	16648.5	50.6	3.7	54.3	68.2	-13.9	Peak	Horizontal
	17779.0	48.0	5.5	53.5	74.0	-20.5	Peak	Horizontal
	17779.0	39.7	5.5	45.2	54.0	-8.8	Average	Horizontal
	11106.5	60.4	-5.3	55.1	74.0	-18.9	Peak	Vertical
	11106.5	43.6	-5.3	38.3	54.0	-15.7	Average	Vertical
*	16640.0	50.5	3.8	54.3	68.2	-13.9	Peak	Vertical
*	17371.0	47.5	5.2	52.7	68.2	-15.5	Peak	Vertical
	17915.0	47.3	5.9	53.2	74.0	-20.8	Peak	Vertical
	17915.0	40.1	5.9	46.0	54.0	-8.0	Average	Vertical

Note 1: "*" is not in restricted band, its limit is -27dBm/MHz. At a distance of 3 meters, the field strength limit in dB μ V/m can be determined by adding a "conversion" factor of 95.2dB to the EIRP limit of -27dBm/MHz to obtain the limit for out of band spurious emissions.

Note 2: Measure Level (dB μ V/m) = Reading Level (dB μ V) + Factor (dB)

Factor (dB) = Cable Loss (dB) + Antenna Factor (dB/m) - Pre_Amplifier Gain (dB)

Test Site	SIP-AC1	Test Engineer	Stephen Dong
Test Date	2021/02/19	Test Channel	134
Test Mode	802.11n-HT40(CDD Mode)		
Remark	1. Average measurement was not performed if peak level lower than average limit. 2. Other frequency was 20dB below limit line within 1-18GHz, there is not show in the report.		

Mark	Frequency (MHz)	Reading Level (dB μ V)	Factor (dB)	Measure Level (dB μ V/m)	Limit (dB μ V/m)	Margin (dB)	Detector	Polarization
	15713.5	49.3	1.7	51.0	74.0	-23.0	Peak	Horizontal
*	16827.0	48.4	4.3	52.7	68.2	-15.5	Peak	Horizontal
*	17286.0	47.8	4.9	52.7	68.2	-15.5	Peak	Horizontal
	18000.0	47.5	6.1	53.6	74.0	-20.4	Peak	Horizontal
	18000.0	41.6	6.1	47.7	54.0	-6.3	Average	Horizontal
	15841.0	48.9	2.7	51.6	74.0	-22.4	Peak	Vertical
*	16878.0	48.2	4.1	52.3	68.2	-15.9	Peak	Vertical
*	17473.0	47.9	4.7	52.6	68.2	-15.6	Peak	Vertical
	17923.5	47.9	5.9	53.8	74.0	-20.2	Peak	Vertical
	17923.5	41.0	5.9	46.9	54.0	-7.1	Average	Horizontal

Note 1: "*" is not in restricted band, its limit is -27dBm/MHz. At a distance of 3 meters, the field strength limit in dB μ V/m can be determined by adding a "conversion" factor of 95.2dB to the EIRP limit of -27dBm/MHz to obtain the limit for out of band spurious emissions.

Note 2: Measure Level (dB μ V/m) = Reading Level (dB μ V) + Factor (dB)

Factor (dB) = Cable Loss (dB) + Antenna Factor (dB/m) - Pre_Amplifier Gain (dB)

Test Site	SIP-AC1	Test Engineer	Stephen Dong
Test Date	2021/02/19	Test Channel	142
Test Mode	802.11n-HT40(CDD Mode)		
Remark	1. Average measurement was not performed if peak level lower than average limit. 2. Other frequency was 20dB below limit line within 1-18GHz, there is not show in the report.		

Mark	Frequency (MHz)	Reading Level (dBμV)	Factor (dB)	Measure Level (dBμV/m)	Limit (dBμV/m)	Margin (dB)	Detector	Polarization
	11412.5	58.4	-5.0	53.4	74.0	-20.6	Peak	Horizontal
	11412.5	43.4	-5.0	38.4	54.0	-15.6	Average	Horizontal
*	16674.0	48.2	3.7	51.9	68.2	-16.3	Peak	Horizontal
*	17133.0	50.3	4.1	54.4	68.2	-13.8	Peak	Horizontal
	17796.0	47.4	6.1	53.5	74.0	-20.5	Peak	Horizontal
	17796.0	41.4	6.1	47.5	54.0	-6.5	Average	Horizontal
	11404.0	60.9	-5.1	55.8	74.0	-18.2	Peak	Vertical
	11404.0	44.4	-5.1	39.3	54.0	-14.7	Average	Vertical
*	16869.5	48.9	4.2	53.1	68.2	-15.1	Peak	Vertical
*	17294.5	48.8	4.9	53.7	68.2	-14.5	Peak	Vertical
	17779.0	48.7	5.5	54.2	74.0	-19.8	Peak	Vertical
	17779.0	39.9	5.5	45.4	54.0	-8.6	Average	Vertical

Note 1: "*" is not in restricted band, its limit is -27dBm/MHz. At a distance of 3 meters, the field strength limit in dBμV/m can be determined by adding a "conversion" factor of 95.2dB to the EIRP limit of -27dBm/MHz to obtain the limit for out of band spurious emissions.

Note 2: Measure Level (dBμV/m) = Reading Level (dBμV) + Factor (dB)

Factor (dB) = Cable Loss (dB) + Antenna Factor (dB/m) - Pre_Amplifier Gain (dB)

Test Site	SIP-AC1	Test Engineer	Stephen Dong
Test Date	2021/02/19	Test Channel	52
Test Mode	802.11ac-VHT20(CDD Mode)		
Remark	1. Average measurement was not performed if peak level lower than average limit. 2. Other frequency was 20dB below limit line within 1-18GHz, there is not show in the report.		

Mark	Frequency (MHz)	Reading Level (dBμV)	Factor (dB)	Measure Level (dBμV/m)	Limit (dBμV/m)	Margin (dB)	Detector	Polarization
	15781.5	51.1	2.5	53.6	74.0	-20.4	Peak	Horizontal
	15781.5	43.6	2.5	46.1	54.0	-7.9	Average	Horizontal
*	16759.0	48.0	4.1	52.1	68.2	-16.1	Peak	Horizontal
*	17481.5	48.4	4.9	53.3	68.2	-14.9	Peak	Horizontal
	17838.5	47.9	5.9	53.8	74.0	-20.2	Peak	Horizontal
	17838.5	41.4	5.9	47.3	54.0	-6.7	Average	Horizontal
	15781.5	50.5	2.5	53.0	74.0	-21.0	Peak	Vertical
	15781.5	43.4	2.5	45.9	54.0	-8.1	Average	Vertical
*	16750.5	47.2	4.2	51.4	68.2	-16.8	Peak	Vertical
*	17371.0	47.4	5.2	52.6	68.2	-15.6	Peak	Vertical
	17974.5	47.3	5.7	53.0	74.0	-21.0	Peak	Vertical
	17974.5	40.5	5.7	46.2	54.0	-7.8	Average	Vertical

Note 1: "*" is not in restricted band, its limit is -27dBm/MHz. At a distance of 3 meters, the field strength limit in dBμV/m can be determined by adding a "conversion" factor of 95.2dB to the EIRP limit of -27dBm/MHz to obtain the limit for out of band spurious emissions.

Note 2: Measure Level (dBμV/m) = Reading Level (dBμV) + Factor (dB)

Factor (dB) = Cable Loss (dB) + Antenna Factor (dB/m) - Pre_Amplifier Gain (dB)

Test Site	SIP-AC1	Test Engineer	Stephen Dong
Test Date	2021/02/19	Test Channel	60
Test Mode	802.11ac-VHT20(CDD Mode)		
Remark	1. Average measurement was not performed if peak level lower than average limit. 2. Other frequency was 20dB below limit line within 1-18GHz, there is not show in the report.		

Mark	Frequency (MHz)	Reading Level (dBμV)	Factor (dB)	Measure Level (dBμV/m)	Limit (dBμV/m)	Margin (dB)	Detector	Polarization
	15900.5	50.8	2.1	52.9	74.0	-21.1	Peak	Horizontal
*	16869.5	48.7	4.2	52.9	68.2	-15.3	Peak	Horizontal
*	17379.5	48.7	5.2	53.9	68.2	-14.3	Peak	Horizontal
	17889.5	48.7	6.0	54.7	74.0	-19.3	Peak	Horizontal
	17889.5	40.5	6.0	46.5	54.0	-7.5	Average	Horizontal
	15900.5	52.2	2.1	54.3	74.0	-19.7	Peak	Vertical
	15900.5	43.7	2.1	45.8	54.0	-8.2	Average	Vertical
*	16504.0	48.8	3.6	52.4	68.2	-15.8	Peak	Vertical
*	17243.5	48.2	4.5	52.7	68.2	-15.5	Peak	Vertical
	17796.0	47.5	6.1	53.6	74.0	-20.4	Peak	Vertical
	17796.0	40.0	6.1	46.1	54.0	-7.9	Average	Vertical

Note 1: "*" is not in restricted band, its limit is -27dBm/MHz. At a distance of 3 meters, the field strength limit in dBμV/m can be determined by adding a "conversion" factor of 95.2dB to the EIRP limit of -27dBm/MHz to obtain the limit for out of band spurious emissions.

Note 2: Measure Level (dBμV/m) = Reading Level (dBμV) + Factor (dB)

Factor (dB) = Cable Loss (dB) + Antenna Factor (dB/m) - Pre_Amplifier Gain (dB)

Test Site	SIP-AC1	Test Engineer	Stephen Dong
Test Date	2021/02/19	Test Channel	64
Test Mode	802.11ac-VHT20(CDD Mode)		
Remark	1. Average measurement was not performed if peak level lower than average limit. 2. Other frequency was 20dB below limit line within 1-18GHz, there is not show in the report.		

Mark	Frequency (MHz)	Reading Level (dBμV)	Factor (dB)	Measure Level (dBμV/m)	Limit (dBμV/m)	Margin (dB)	Detector	Polarization
	15968.5	52.9	2.3	55.2	74.0	-18.8	Peak	Horizontal
	15968.5	43.6	2.3	45.9	54.0	-8.1	Average	Horizontal
*	16869.5	48.8	4.2	53.0	68.2	-15.2	Peak	Horizontal
*	17422.0	47.9	5.0	52.9	68.2	-15.3	Peak	Horizontal
	17753.5	48.3	5.5	53.8	74.0	-20.2	Peak	Horizontal
	17753.5	40.4	5.5	45.9	54.0	-8.1	Average	Horizontal
	15960.0	53.0	2.3	55.3	74.0	-18.7	Peak	Vertical
	15960.0	45.4	2.3	47.7	54.0	-6.3	Average	Vertical
*	16478.5	49.1	3.4	52.5	68.2	-15.7	Peak	Vertical
*	17379.5	47.8	5.2	53.0	68.2	-15.2	Peak	Vertical
	17847.0	47.4	6.0	53.4	74.0	-20.6	Peak	Vertical
	17847.0	40.6	6.0	46.6	54.0	-7.4	Average	Vertical

Note 1: "*" is not in restricted band, its limit is -27dBm/MHz. At a distance of 3 meters, the field strength limit in dBμV/m can be determined by adding a "conversion" factor of 95.2dB to the EIRP limit of -27dBm/MHz to obtain the limit for out of band spurious emissions.

Note 2: Measure Level (dBμV/m) = Reading Level (dBμV) + Factor (dB)

Factor (dB) = Cable Loss (dB) + Antenna Factor (dB/m) - Pre_Amplifier Gain (dB)

Test Site	SIP-AC1	Test Engineer	Stephen Dong
Test Date	2021/02/19	Test Channel	100
Test Mode	802.11ac-VHT20(CDD Mode)		
Remark	1. Average measurement was not performed if peak level lower than average limit. 2. Other frequency was 20dB below limit line within 1-18GHz, there is not show in the report.		

Mark	Frequency (MHz)	Reading Level (dB μ V)	Factor (dB)	Measure Level (dB μ V/m)	Limit (dB μ V/m)	Margin (dB)	Detector	Polarization
	10996.0	59.0	-5.3	53.7	74.0	-20.3	Peak	Horizontal
	10996.0	45.3	-5.3	40.0	54.0	-14.0	Average	Horizontal
*	16504.0	49.4	3.6	53.0	68.2	-15.2	Peak	Horizontal
*	17303.0	48.2	4.9	53.1	68.2	-15.1	Peak	Horizontal
	17889.5	47.6	6.0	53.6	74.0	-20.4	Peak	Horizontal
	17889.5	40.9	6.0	46.9	54.0	-7.1	Average	Horizontal
	10996.0	59.0	-5.3	53.7	74.0	-20.3	Peak	Vertical
	10996.0	43.6	-5.3	38.3	54.0	-15.7	Average	Vertical
*	16495.5	49.8	3.5	53.3	68.2	-14.9	Peak	Vertical
*	17388.0	48.0	5.3	53.3	68.2	-14.9	Peak	Vertical
	17898.0	47.0	6.2	53.2	74.0	-20.8	Peak	Vertical
	17898.0	37.4	6.2	43.6	54.0	-10.4	Average	Vertical

Note 1: "*" is not in restricted band, its limit is -27dBm/MHz. At a distance of 3 meters, the field strength limit in dB μ V/m can be determined by adding a "conversion" factor of 95.2dB to the EIRP limit of -27dBm/MHz to obtain the limit for out of band spurious emissions.

Note 2: Measure Level (dB μ V/m) = Reading Level (dB μ V) + Factor (dB)

Factor (dB) = Cable Loss (dB) + Antenna Factor (dB/m) - Pre_Amplifier Gain (dB)

Test Site	SIP-AC1	Test Engineer	Stephen Dong
Test Date	2021/02/19	Test Channel	116
Test Mode	802.11ac-VHT20(CDD Mode)		
Remark	1. Average measurement was not performed if peak level lower than average limit. 2. Other frequency was 20dB below limit line within 1-18GHz, there is not show in the report.		

Mark	Frequency (MHz)	Reading Level (dBμV)	Factor (dB)	Measure Level (dBμV/m)	Limit (dBμV/m)	Margin (dB)	Detector	Polarization
	11157.5	62.1	-5.3	56.8	74.0	-17.2	Peak	Horizontal
	11157.5	45.4	-5.3	40.1	54.0	-13.9	Average	Horizontal
*	16733.5	49.0	4.2	53.2	68.2	-15.0	Peak	Horizontal
*	17379.5	47.7	5.2	52.9	68.2	-15.3	Peak	Horizontal
	17957.5	47.9	5.8	53.7	74.0	-20.3	Peak	Horizontal
	17957.5	41.7	5.8	47.5	54.0	-6.5	Average	Horizontal
	11157.5	57.6	-5.3	52.3	74.0	-21.7	Peak	Vertical
*	16742.0	49.6	4.2	53.8	68.2	-14.4	Peak	Vertical
*	17294.5	48.2	4.9	53.1	68.2	-15.1	Peak	Vertical
	17974.5	48.0	5.7	53.7	74.0	-20.3	Peak	Vertical
	17974.5	41.9	5.7	47.6	54.0	-6.4	Average	Vertical

Note 1: "*" is not in restricted band, its limit is -27dBm/MHz. At a distance of 3 meters, the field strength limit in dBμV/m can be determined by adding a "conversion" factor of 95.2dB to the EIRP limit of -27dBm/MHz to obtain the limit for out of band spurious emissions.

Note 2: Measure Level (dBμV/m) = Reading Level (dBμV) + Factor (dB)

Factor (dB) = Cable Loss (dB) + Antenna Factor (dB/m) - Pre_Amplifier Gain (dB)

Test Site	SIP-AC1	Test Engineer	Stephen Dong
Test Date	2021/02/19	Test Channel	140
Test Mode	802.11ac-VHT20(CDD Mode)		
Remark	1. Average measurement was not performed if peak level lower than average limit. 2. Other frequency was 20dB below limit line within 1-18GHz, there is not show in the report.		

Mark	Frequency (MHz)	Reading Level (dB μ V)	Factor (dB)	Measure Level (dB μ V/m)	Limit (dB μ V/m)	Margin (dB)	Detector	Polarization
	15858.0	48.3	2.7	51.0	74.0	-23.0	Peak	Horizontal
*	16784.5	48.6	4.1	52.7	68.2	-15.5	Peak	Horizontal
*	17116.0	48.9	3.8	52.7	68.2	-15.5	Peak	Horizontal
	17745.0	47.3	5.8	53.1	74.0	-20.9	Peak	Horizontal
	17745.0	41.5	5.8	47.3	54.0	-6.7	Average	Horizontal
	11404.0	57.0	-5.1	51.9	74.0	-22.1	Peak	Vertical
*	16614.5	49.1	3.5	52.6	68.2	-15.6	Peak	Vertical
*	17294.5	48.5	4.9	53.4	68.2	-14.8	Peak	Vertical
	17932.0	48.2	5.9	54.1	74.0	-19.9	Peak	Vertical
	17932.0	41.4	5.9	47.3	54.0	-6.7	Average	Vertical

Note 1: "*" is not in restricted band, its limit is -27dBm/MHz. At a distance of 3 meters, the field strength limit in dB μ V/m can be determined by adding a "conversion" factor of 95.2dB to the EIRP limit of -27dBm/MHz to obtain the limit for out of band spurious emissions.

Note 2: Measure Level (dB μ V/m) = Reading Level (dB μ V) + Factor (dB)

Factor (dB) = Cable Loss (dB) + Antenna Factor (dB/m) - Pre_Amplifier Gain (dB)

Test Site	SIP-AC1	Test Engineer	Stephen Dong
Test Date	2021/02/19	Test Channel	144
Test Mode	802.11ac-VHT20(CDD Mode)		
Remark	1. Average measurement was not performed if peak level lower than average limit. 2. Other frequency was 20dB below limit line within 1-18GHz, there is not show in the report.		

Mark	Frequency (MHz)	Reading Level (dBμV)	Factor (dB)	Measure Level (dBμV/m)	Limit (dBμV/m)	Margin (dB)	Detector	Polarization
	15858.0	48.6	2.7	51.3	74.0	-22.7	Peak	Horizontal
*	16512.5	48.2	3.4	51.6	68.2	-16.6	Peak	Horizontal
*	17175.5	49.3	4.2	53.5	68.2	-14.7	Peak	Horizontal
	18000.0	47.5	6.1	53.6	74.0	-20.4	Peak	Horizontal
	18000.0	43.5	6.1	49.6	54.0	-4.4	Average	Horizontal
*	16266.0	49.0	2.8	51.8	68.2	-16.4	Peak	Vertical
*	17260.5	48.8	4.4	53.2	68.2	-15.0	Peak	Vertical
	17745.0	48.8	5.8	54.6	74.0	-19.4	Peak	Vertical
	17745.0	40.5	5.8	46.3	54.0	-7.7	Average	Vertical
	17923.5	48.3	5.9	54.2	74.0	-19.8	Peak	Vertical
	17923.5	41.1	5.9	47.0	54.0	-7.0	Average	Vertical

Note 1: "*" is not in restricted band, its limit is -27dBm/MHz. At a distance of 3 meters, the field strength limit in dBμV/m can be determined by adding a "conversion" factor of 95.2dB to the EIRP limit of -27dBm/MHz to obtain the limit for out of band spurious emissions.

Note 2: Measure Level (dBμV/m) = Reading Level (dBμV) + Factor (dB)

Factor (dB) = Cable Loss (dB) + Antenna Factor (dB/m) - Pre_Amplifier Gain (dB)

Test Site	SIP-AC1	Test Engineer	Stephen Dong
Test Date	2021/02/19	Test Channel	54
Test Mode	802.11ac-VHT40(CDD Mode)		
Remark	3. Average measurement was not performed if peak level lower than average limit. 4. Other frequency was 20dB below limit line within 1-18GHz, there is not show in the report.		

Mark	Frequency (MHz)	Reading Level (dBμV)	Factor (dB)	Measure Level (dBμV/m)	Limit (dBμV/m)	Margin (dB)	Detector	Polarization
*	10545.5	57.5	-5.6	51.9	68.2	-16.3	Peak	Horizontal
	15815.5	52.9	2.1	55.0	74.0	-19.0	Peak	Horizontal
	15815.5	44.9	2.1	47.0	54.0	-7.0	Average	Horizontal
*	17226.5	49.0	4.4	53.4	68.2	-14.8	Peak	Horizontal
	17847.0	48.3	6.0	54.3	74.0	-19.7	Peak	Horizontal
	17847.0	40.6	6.0	46.6	54.0	-7.4	Average	Horizontal
*	10528.5	59.3	-5.6	53.7	68.2	-14.5	Peak	Vertical
	15798.5	53.1	2.1	55.2	74.0	-18.8	Peak	Vertical
	15798.5	45.2	2.1	47.3	54.0	-6.7	Average	Vertical
*	16861.0	49.0	4.2	53.2	68.2	-15.0	Peak	Vertical
	17881.0	48.2	5.8	54.0	74.0	-20.0	Peak	Vertical
	17881.0	38.7	5.8	44.5	54.0	-9.5	Average	Vertical

Note 1: "*" is not in restricted band, its limit is -27dBm/MHz. At a distance of 3 meters, the field strength limit in dBμV/m can be determined by adding a "conversion" factor of 95.2dB to the EIRP limit of -27dBm/MHz to obtain the limit for out of band spurious emissions.

Note 2: Measure Level (dBμV/m) = Reading Level (dBμV) + Factor (dB)

Factor (dB) = Cable Loss (dB) + Antenna Factor (dB/m) - Pre_Amplifier Gain (dB)

Test Site	SIP-AC1	Test Engineer	Stephen Dong
Test Date	2021/02/19	Test Channel	62
Test Mode	802.11ac-VHT40(CDD Mode)		
Remark	3. Average measurement was not performed if peak level lower than average limit. 4. Other frequency was 20dB below limit line within 1-18GHz, there is not show in the report.		

Mark	Frequency (MHz)	Reading Level (dBμV)	Factor (dB)	Measure Level (dBμV/m)	Limit (dBμV/m)	Margin (dB)	Detector	Polarization
	15926.0	52.3	2.2	54.5	74.0	-19.5	Peak	Horizontal
	15926.0	43.6	2.2	45.8	54.0	-8.2	Average	Horizontal
*	16886.5	48.2	4.0	52.2	68.2	-16.0	Peak	Horizontal
*	17439.0	48.0	5.1	53.1	68.2	-15.1	Peak	Horizontal
	17728.0	47.9	5.4	53.3	74.0	-20.7	Peak	Horizontal
	17728.0	41.9	5.4	47.3	54.0	-6.7	Average	Horizontal
	15934.5	53.2	2.2	55.4	74.0	-18.6	Peak	Vertical
	15934.5	45.1	2.2	47.3	54.0	-6.7	Average	Vertical
*	16733.5	48.7	4.2	52.9	68.2	-15.3	Peak	Vertical
*	17311.5	49.2	4.7	53.9	68.2	-14.3	Peak	Vertical
	17728.0	48.6	5.4	54.0	74.0	-20.0	Peak	Vertical
	17728.0	41.4	5.4	46.8	54.0	-7.2	Average	Vertical

Note 1: "*" is not in restricted band, its limit is -27dBm/MHz. At a distance of 3 meters, the field strength limit in dBμV/m can be determined by adding a "conversion" factor of 95.2dB to the EIRP limit of -27dBm/MHz to obtain the limit for out of band spurious emissions.

Note 2: Measure Level (dBμV/m) = Reading Level (dBμV) + Factor (dB)

Factor (dB) = Cable Loss (dB) + Antenna Factor (dB/m) - Pre_Amplifier Gain (dB)

Test Site	SIP-AC1	Test Engineer	Stephen Dong
Test Date	2021/02/19	Test Channel	102
Test Mode	802.11ac-VHT40(CDD Mode)		
Remark	3. Average measurement was not performed if peak level lower than average limit. 4. Other frequency was 20dB below limit line within 1-18GHz, there is not show in the report.		

Mark	Frequency (MHz)	Reading Level (dBμV)	Factor (dB)	Measure Level (dBμV/m)	Limit (dBμV/m)	Margin (dB)	Detector	Polarization
	11021.5	62.5	-5.2	57.3	74.0	-16.7	Peak	Horizontal
	11021.5	52.1	-5.2	46.9	54.0	-7.1	Average	Horizontal
*	16529.5	50.8	3.2	54.0	68.2	-14.2	Peak	Horizontal
*	17371.0	47.5	5.2	52.7	68.2	-15.5	Peak	Horizontal
	17898.0	47.7	6.2	53.9	74.0	-20.1	Peak	Horizontal
	17898.0	41.8	6.2	48.0	54.0	-6.0	Average	Horizontal
	11013.0	59.8	-5.1	54.7	74.0	-19.3	Peak	Vertical
	11013.0	46.4	-5.1	41.3	54.0	-12.7	Average	Vertical
*	16538.0	52.4	3.1	55.5	68.2	-12.7	Peak	Vertical
*	17286.0	48.0	4.9	52.9	68.2	-15.3	Peak	Vertical
	17830.0	47.5	5.8	53.3	74.0	-20.7	Peak	Vertical
	17830.0	41.6	5.8	47.4	54.0	-6.6	Average	Vertical

Note 1: "*" is not in restricted band, its limit is -27dBm/MHz. At a distance of 3 meters, the field strength limit in dBμV/m can be determined by adding a "conversion" factor of 95.2dB to the EIRP limit of -27dBm/MHz to obtain the limit for out of band spurious emissions.

Note 2: Measure Level (dBμV/m) = Reading Level (dBμV) + Factor (dB)

Factor (dB) = Cable Loss (dB) + Antenna Factor (dB/m) - Pre_Amplifier Gain (dB)

Test Site	SIP-AC1	Test Engineer	Stephen Dong
Test Date	2021/02/19	Test Channel	110
Test Mode	802.11ac-VHT40(CDD Mode)		
Remark	3. Average measurement was not performed if peak level lower than average limit. 4. Other frequency was 20dB below limit line within 1-18GHz, there is not show in the report.		

Mark	Frequency (MHz)	Reading Level (dB μ V)	Factor (dB)	Measure Level (dB μ V/m)	Limit (dB μ V/m)	Margin (dB)	Detector	Polarization
	11098.0	60.5	-5.3	55.2	74.0	-18.8	Peak	Horizontal
	11098.0	47.9	-5.3	42.6	54.0	-11.4	Average	Horizontal
*	16657.0	52.1	3.5	55.6	68.2	-12.6	Peak	Horizontal
*	17379.5	47.9	5.2	53.1	68.2	-15.1	Peak	Horizontal
	17915.0	48.4	5.9	54.3	74.0	-19.7	Peak	Horizontal
	17915.0	41.4	5.9	47.3	54.0	-6.7	Average	Horizontal
	11098.0	61.4	-5.3	56.1	74.0	-17.9	Peak	Vertical
	11098.0	56.4	-5.3	51.1	54.0	-2.9	Average	Vertical
*	16657.0	52.3	3.5	55.8	68.2	-12.4	Peak	Vertical
*	17277.5	48.2	4.6	52.8	68.2	-15.4	Peak	Vertical
	18000.0	47.5	6.1	53.6	74.0	-20.4	Peak	Vertical
	18000.0	42.0	6.1	48.1	54.0	-5.9	Average	Vertical

Note 1: "*" is not in restricted band, its limit is -27dBm/MHz. At a distance of 3 meters, the field strength limit in dB μ V/m can be determined by adding a "conversion" factor of 95.2dB to the EIRP limit of -27dBm/MHz to obtain the limit for out of band spurious emissions.

Note 2: Measure Level (dB μ V/m) = Reading Level (dB μ V) + Factor (dB)

Factor (dB) = Cable Loss (dB) + Antenna Factor (dB/m) - Pre_Amplifier Gain (dB)

Test Site	SIP-AC1	Test Engineer	Stephen Dong
Test Date	2021/02/19	Test Channel	134
Test Mode	802.11ac-VHT40(CDD Mode)		
Remark	3. Average measurement was not performed if peak level lower than average limit. 4. Other frequency was 20dB below limit line within 1-18GHz, there is not show in the report.		

Mark	Frequency (MHz)	Reading Level (dBμV)	Factor (dB)	Measure Level (dBμV/m)	Limit (dBμV/m)	Margin (dB)	Detector	Polarization
	11336.0	59.7	-5.0	54.7	74.0	-19.3	Peak	Horizontal
	11336.0	49.0	-5.0	44.0	54.0	-10.0	Average	Horizontal
*	16997.0	52.5	3.7	56.2	68.2	-12.0	Peak	Horizontal
*	17541.0	47.6	4.8	52.4	68.2	-15.8	Peak	Horizontal
	17991.5	47.7	5.9	53.6	74.0	-20.4	Peak	Horizontal
	17991.5	40.0	5.9	45.9	54.0	-8.1	Average	Horizontal
	11327.5	62.6	-5.0	57.6	74.0	-16.4	Peak	Vertical
	11327.5	51.9	-5.0	46.9	54.0	-7.1	Average	Vertical
*	17014.0	52.4	3.6	56.0	68.2	-12.2	Peak	Vertical
*	17328.5	47.7	4.7	52.4	68.2	-15.8	Peak	Vertical
	17838.5	47.9	5.9	53.8	74.0	-20.2	Peak	Vertical
	17838.5	38.6	5.9	44.5	54.0	-9.5	Average	Vertical

Note 1: "*" is not in restricted band, its limit is -27dBm/MHz. At a distance of 3 meters, the field strength limit in dBμV/m can be determined by adding a "conversion" factor of 95.2dB to the EIRP limit of -27dBm/MHz to obtain the limit for out of band spurious emissions.

Note 2: Measure Level (dBμV/m) = Reading Level (dBμV) + Factor (dB)

Factor (dB) = Cable Loss (dB) + Antenna Factor (dB/m) - Pre_Amplifier Gain (dB)

Test Site	SIP-AC1	Test Engineer	Stephen Dong
Test Date	2021/02/19	Test Channel	142
Test Mode	802.11ac-VHT40(CDD Mode)		
Remark	3. Average measurement was not performed if peak level lower than average limit. 4. Other frequency was 20dB below limit line within 1-18GHz, there is not show in the report.		

Mark	Frequency (MHz)	Reading Level (dBμV)	Factor (dB)	Measure Level (dBμV/m)	Limit (dBμV/m)	Margin (dB)	Detector	Polarization
	11421.0	63.6	-4.9	58.7	74.0	-15.3	Peak	Horizontal
	11421.0	53.4	-4.9	48.5	54.0	-5.5	Average	Horizontal
*	16419.0	48.3	3.7	52.0	68.2	-16.2	Peak	Horizontal
*	17133.0	51.0	4.1	55.1	68.2	-13.1	Peak	Horizontal
	17906.5	47.6	6.0	53.6	74.0	-20.4	Peak	Horizontal
	17906.5	40.5	6.0	46.5	54.0	-7.5	Average	Horizontal
	11421.0	61.1	-4.9	56.2	74.0	-17.8	Peak	Vertical
	11421.0	50.3	-4.9	45.4	54.0	-8.6	Average	Vertical
*	16784.5	48.6	4.1	52.7	68.2	-15.5	Peak	Vertical
*	17133.0	51.5	4.1	55.6	68.2	-12.6	Peak	Vertical
	17881.0	47.2	5.8	53.0	74.0	-21.0	Peak	Vertical
	17881.0	39.8	5.8	45.6	54.0	-8.4	Average	Vertical

Note 1: "*" is not in restricted band, its limit is -27dBm/MHz. At a distance of 3 meters, the field strength limit in dBμV/m can be determined by adding a "conversion" factor of 95.2dB to the EIRP limit of -27dBm/MHz to obtain the limit for out of band spurious emissions.

Note 2: Measure Level (dBμV/m) = Reading Level (dBμV) + Factor (dB)

Factor (dB) = Cable Loss (dB) + Antenna Factor (dB/m) - Pre_Amplifier Gain (dB)

Test Site	SIP-AC1	Test Engineer	Stephen Dong
Test Date	2021/02/19	Test Channel	58
Test Mode	802.11ac-VHT80(CDD Mode)		
Remark	1. Average measurement was not performed if peak level lower than average limit. 2. Other frequency was 20dB below limit line within 1-18GHz, there is not show in the report.		

Mark	Frequency (MHz)	Reading Level (dB μ V)	Factor (dB)	Measure Level (dB μ V/m)	Limit (dB μ V/m)	Margin (dB)	Detector	Polarization
	8463.0	52.7	-4.5	48.2	74.0	-25.8	Peak	Horizontal
	12415.5	49.7	-2.4	47.3	74.0	-26.7	Peak	Horizontal
*	16699.5	47.2	5.0	52.2	68.2	-16.0	Peak	Horizontal
*	17677.0	48.1	5.7	53.8	68.2	-14.4	Peak	Horizontal
	8463.0	54.2	-4.5	49.7	74.0	-24.3	Peak	Vertical
	11378.5	50.6	-3.5	47.1	74.0	-26.9	Peak	Vertical
*	14294.0	48.6	1.4	50.0	68.2	-18.2	Peak	Vertical
*	16495.5	48.2	4.8	53.0	68.2	-15.2	Peak	Vertical

Note 1: "*" is not in restricted band, its limit is -27dBm/MHz. At a distance of 3 meters, the field strength limit in dB μ V/m can be determined by adding a "conversion" factor of 95.2dB to the EIRP limit of -27dBm/MHz to obtain the limit for out of band spurious emissions.

Note 2: Measure Level (dB μ V/m) = Reading Level (dB μ V) + Factor (dB)

Factor (dB) = Cable Loss (dB) + Antenna Factor (dB/m) - Pre_Amplifier Gain (dB)

Test Site	SIP-AC1	Test Engineer	Stephen Dong
Test Date	2021/02/19	Test Channel	106
Test Mode	802.11ac-VHT80(CDD Mode)		
Remark	1. Average measurement was not performed if peak level lower than average limit. 2. Other frequency was 20dB below limit line within 1-18GHz, there is not show in the report.		

Mark	Frequency (MHz)	Reading Level (dBμV)	Factor (dB)	Measure Level (dBμV/m)	Limit (dBμV/m)	Margin (dB)	Detector	Polarization
	10979.0	50.0	-3.1	46.9	74.0	-27.1	Peak	Horizontal
	11489.0	50.8	-3.0	47.8	74.0	-26.2	Peak	Horizontal
*	14064.5	48.7	0.9	49.6	68.2	-18.6	Peak	Horizontal
*	16733.5	47.7	4.7	52.4	68.2	-15.8	Peak	Horizontal
	10826.0	50.1	-3.3	46.8	74.0	-27.2	Peak	Vertical
	11956.5	50.7	-3.6	47.1	74.0	-26.9	Peak	Vertical
*	13979.5	49.5	0.6	50.1	68.2	-18.1	Peak	Vertical
*	16606.0	48.1	4.7	52.8	68.2	-15.4	Peak	Vertical

Note 1: "*" is not in restricted band, its limit is -27dBm/MHz. At a distance of 3 meters, the field strength limit in dBμV/m can be determined by adding a "conversion" factor of 95.2dB to the EIRP limit of -27dBm/MHz to obtain the limit for out of band spurious emissions.

Note 2: Measure Level (dBμV/m) = Reading Level (dBμV) + Factor (dB)

Factor (dB) = Cable Loss (dB) + Antenna Factor (dB/m) - Pre_Amplifier Gain (dB)

Test Site	SIP-AC1	Test Engineer	Stephen Dong
Test Date	2021/02/19	Test Channel	122
Test Mode	802.11ac-VHT80(CDD Mode)		
Remark	1. Average measurement was not performed if peak level lower than average limit. 2. Other frequency was 20dB below limit line within 1-18GHz, there is not show in the report.		

Mark	Frequency (MHz)	Reading Level (dB μ V)	Factor (dB)	Measure Level (dB μ V/m)	Limit (dB μ V/m)	Margin (dB)	Detector	Polarization
	11242.5	57.2	-3.6	53.6	74.0	-20.4	Peak	Horizontal
	11242.5	42.3	-3.6	38.7	54.0	-15.3	Average	Horizontal
	12356.0	50.1	-3.1	47.0	74.0	-27.0	Peak	Horizontal
*	14634.0	47.6	2.1	49.7	68.2	-18.5	Peak	Horizontal
*	16869.5	49.5	4.8	54.3	68.2	-13.9	Peak	Horizontal
	11242.5	59.3	-3.6	55.7	74.0	-18.3	Peak	Vertical
	11242.5	45.2	-3.6	41.6	54.0	-12.4	Average	Vertical
	12381.5	50.8	-3.0	47.8	74.0	-26.2	Peak	Vertical
*	14464.0	48.3	1.8	50.1	68.2	-18.1	Peak	Vertical
*	16861.0	51.3	4.8	56.1	68.2	-12.1	Peak	Vertical

Note 1: "*" is not in restricted band, its limit is -27dBm/MHz. At a distance of 3 meters, the field strength limit in dB μ V/m can be determined by adding a "conversion" factor of 95.2dB to the EIRP limit of -27dBm/MHz to obtain the limit for out of band spurious emissions.

Note 2: Measure Level (dB μ V/m) = Reading Level (dB μ V) + Factor (dB)

Factor (dB) = Cable Loss (dB) + Antenna Factor (dB/m) - Pre_Amplifier Gain (dB)

Test Site	SIP-AC1	Test Engineer	Stephen Dong
Test Date	2021/02/19	Test Channel	138
Test Mode	802.11ac-VHT80(CDD Mode)		
Remark	1. Average measurement was not performed if peak level lower than average limit. 2. Other frequency was 20dB below limit line within 1-18GHz, there is not show in the report.		

Mark	Frequency (MHz)	Reading Level (dB μ V)	Factor (dB)	Measure Level (dB μ V/m)	Limit (dB μ V/m)	Margin (dB)	Detector	Polarization
	10792.0	49.5	-3.2	46.3	74.0	-27.7	Peak	Horizontal
	11395.5	56.7	-3.6	53.1	74.0	-20.9	Peak	Horizontal
	11395.5	43.9	-3.6	40.3	54.0	-13.7	Average	Horizontal
*	14736.0	47.3	2.1	49.4	68.2	-18.8	Peak	Horizontal
*	17090.5	48.4	4.6	53.0	68.2	-15.2	Peak	Horizontal
	11404.0	57.5	-3.6	53.9	74.0	-20.1	Peak	Vertical
	11404.0	44.4	-3.6	40.8	54.0	-13.2	Average	Vertical
	12407.0	49.3	-2.1	47.2	74.0	-26.8	Peak	Vertical
*	14413.0	48.5	1.4	49.9	68.2	-18.3	Peak	Vertical
*	17090.5	48.0	4.6	52.6	68.2	-15.6	Peak	Vertical

Note 1: "*" is not in restricted band, its limit is -27dBm/MHz. At a distance of 3 meters, the field strength limit in dB μ V/m can be determined by adding a "conversion" factor of 95.2dB to the EIRP limit of -27dBm/MHz to obtain the limit for out of band spurious emissions.

Note 2: Measure Level (dB μ V/m) = Reading Level (dB μ V) + Factor (dB)

Factor (dB) = Cable Loss (dB) + Antenna Factor (dB/m) - Pre_Amplifier Gain (dB)

Test Site	SIP-AC3	Test Engineer	Edward Zhang
Test Date	2021/02/25	Test Channel	52
Test Mode	802.11n-HT20(Beamforming mode)		
Remark	3. Average measurement was not performed if peak level lower than average limit. 4. Other frequency was 20dB below limit line within 1-18GHz, there is not show in the report.		

Mark	Frequency (MHz)	Reading Level (dBμV)	Factor (dB)	Measure Level (dBμV/m)	Limit (dBμV/m)	Margin (dB)	Detector	Polarization
	11880.0	50.5	-2.7	47.8	74.0	-26.2	Peak	Horizontal
*	13741.5	48.8	0.7	49.5	68.2	-18.7	Peak	Horizontal
*	16699.5	46.9	5.8	52.7	68.2	-15.5	Peak	Horizontal
	17991.5	46.8	6.8	53.6	74.0	-20.4	Peak	Horizontal
	17991.5	36.9	6.8	43.7	54.0	-10.3	Average	Horizontal
	8412.0	53.3	-4.2	49.1	74.0	-24.9	Peak	Vertical
*	14107.0	48.5	1.4	49.9	68.2	-18.3	Peak	Vertical
*	16674.0	46.9	5.8	52.7	68.2	-15.5	Peak	Vertical
	17821.5	46.6	7.2	53.8	74.0	-20.2	Peak	Vertical
	17821.5	37.5	7.2	44.7	54.0	-9.3	Average	Vertical

Note 1: "*" is not in restricted band, its limit is -27dBm/MHz. At a distance of 3 meters, the field strength limit in dBμV/m can be determined by adding a "conversion" factor of 95.2dB to the EIRP limit of -27dBm/MHz to obtain the limit for out of band spurious emissions.

Note 2: Measure Level (dBμV/m) = Reading Level (dBμV) + Factor (dB)

Factor (dB) = Cable Loss (dB) + Antenna Factor (dB/m) - Pre_Amplifier Gain (dB)

Test Site	SIP-AC3	Test Engineer	Edward Zhang
Test Date	2021/02/25	Test Channel	60
Test Mode	802.11n-HT20(Beamforming mode)		
Remark	3. Average measurement was not performed if peak level lower than average limit. 4. Other frequency was 20dB below limit line within 1-18GHz, there is not show in the report.		

Mark	Frequency (MHz)	Reading Level (dB μ V)	Factor (dB)	Measure Level (dB μ V/m)	Limit (dB μ V/m)	Margin (dB)	Detector	Polarization
*	14022.0	48.9	1.2	50.1	68.2	-18.1	Peak	Horizontal
	16053.5	47.0	5.0	52.0	74.0	-22.0	Peak	Horizontal
*	16801.5	47.2	5.5	52.7	68.2	-15.5	Peak	Horizontal
	17804.5	47.6	7.1	54.7	74.0	-19.3	Peak	Horizontal
	17804.5	34.0	7.1	41.1	54.0	-12.9	Average	Horizontal
	12305.0	49.8	-1.7	48.1	74.0	-25.9	Peak	Vertical
*	14676.5	48.3	2.5	50.8	68.2	-17.4	Peak	Vertical
*	16478.5	47.9	5.5	53.4	68.2	-14.8	Peak	Vertical
	17779.0	47.4	7.3	54.7	74.0	-19.3	Peak	Vertical
	17779.0	34.1	7.3	41.4	54.0	-12.6	Average	Vertical

Note 1: "*" is not in restricted band, its limit is -27dBm/MHz. At a distance of 3 meters, the field strength limit in dB μ V/m can be determined by adding a "conversion" factor of 95.2dB to the EIRP limit of -27dBm/MHz to obtain the limit for out of band spurious emissions.

Note 2: Measure Level (dB μ V/m) = Reading Level (dB μ V) + Factor (dB)

Factor (dB) = Cable Loss (dB) + Antenna Factor (dB/m) - Pre_Amplifier Gain (dB)

Test Site	SIP-AC3	Test Engineer	Edward Zhang
Test Date	2021/02/25	Test Channel	64
Test Mode	802.11n-HT20(Beamforming mode)		
Remark	3. Average measurement was not performed if peak level lower than average limit. 4. Other frequency was 20dB below limit line within 1-18GHz, there is not show in the report.		

Mark	Frequency (MHz)	Reading Level (dB μ V)	Factor (dB)	Measure Level (dB μ V/m)	Limit (dB μ V/m)	Margin (dB)	Detector	Polarization
*	14039.0	49.0	1.4	50.4	68.2	-17.8	Peak	Horizontal
	15892.0	47.9	4.0	51.9	74.0	-22.1	Peak	Horizontal
*	16691.0	46.7	5.7	52.4	68.2	-15.8	Peak	Horizontal
	17864.0	46.3	7.4	53.7	74.0	-20.3	Peak	Horizontal
	17864.0	37.6	7.4	45.0	54.0	-9.0	Average	Horizontal
*	14039.0	49.0	1.4	50.4	68.2	-17.8	Peak	Vertical
	15892.0	47.9	4.0	51.9	74.0	-22.1	Peak	Vertical
*	16691.0	46.7	5.7	52.4	68.2	-15.8	Peak	Vertical
	17864.0	46.3	7.4	53.7	74.0	-20.3	Peak	Vertical
	17864.0	37.6	7.4	45.0	54.0	-9.0	Average	Vertical

Note 1: "*" is not in restricted band, its limit is -27dBm/MHz. At a distance of 3 meters, the field strength limit in dB μ V/m can be determined by adding a "conversion" factor of 95.2dB to the EIRP limit of -27dBm/MHz to obtain the limit for out of band spurious emissions.

Note 2: Measure Level (dB μ V/m) = Reading Level (dB μ V) + Factor (dB)

Factor (dB) = Cable Loss (dB) + Antenna Factor (dB/m) - Pre_Amplifier Gain (dB)

Test Site	SIP-AC3	Test Engineer	Edward Zhang
Test Date	2021/02/25	Test Channel	100
Test Mode	802.11n-HT20(Beamforming mode)		
Remark	3. Average measurement was not performed if peak level lower than average limit. 4. Other frequency was 20dB below limit line within 1-18GHz, there is not show in the report.		

Mark	Frequency (MHz)	Reading Level (dB μ V)	Factor (dB)	Measure Level (dB μ V/m)	Limit (dB μ V/m)	Margin (dB)	Detector	Polarization
*	14285.5	48.6	1.9	50.5	68.2	-17.7	Peak	Horizontal
	16155.5	46.7	5.1	51.8	74.0	-22.2	Peak	Horizontal
*	17473.0	47.5	6.2	53.7	68.2	-14.5	Peak	Horizontal
	17745.0	46.7	7.0	53.7	74.0	-20.3	Peak	Horizontal
	17745.0	38.2	7.0	45.2	54.0	-8.8	Average	Horizontal
*	14047.5	48.1	1.6	49.7	68.2	-18.5	Peak	Vertical
	15960.0	47.1	4.5	51.6	74.0	-22.4	Peak	Vertical
*	16563.5	47.5	5.2	52.7	68.2	-15.5	Peak	Vertical
	17855.5	46.6	7.2	53.8	74.0	-20.2	Peak	Vertical
	17855.5	37.4	7.2	44.6	54.0	-9.4	Average	Vertical

Note 1: "*" is not in restricted band, its limit is -27dBm/MHz. At a distance of 3 meters, the field strength limit in dB μ V/m can be determined by adding a "conversion" factor of 95.2dB to the EIRP limit of -27dBm/MHz to obtain the limit for out of band spurious emissions.

Note 2: Measure Level (dB μ V/m) = Reading Level (dB μ V) + Factor (dB)

Factor (dB) = Cable Loss (dB) + Antenna Factor (dB/m) - Pre_Amplifier Gain (dB)

Test Site	SIP-AC3	Test Engineer	Edward Zhang
Test Date	2021/02/25	Test Channel	116
Test Mode	802.11n-HT20(Beamforming mode)		
Remark	3. Average measurement was not performed if peak level lower than average limit. 4. Other frequency was 20dB below limit line within 1-18GHz, there is not show in the report.		

Mark	Frequency (MHz)	Reading Level (dB μ V)	Factor (dB)	Measure Level (dB μ V/m)	Limit (dB μ V/m)	Margin (dB)	Detector	Polarization
*	14217.5	47.7	1.9	49.6	68.2	-18.6	Peak	Horizontal
	15535.0	47.3	3.8	51.1	74.0	-22.9	Peak	Horizontal
*	16623.0	47.6	5.0	52.6	68.2	-15.6	Peak	Horizontal
	17779.0	47.8	7.3	55.1	74.0	-18.9	Peak	Horizontal
	17779.0	34.9	7.3	42.2	54.0	-11.8	Average	Horizontal
*	14957.0	47.5	2.7	50.2	68.2	-18.0	Peak	Vertical
	15841.0	47.6	4.5	52.1	74.0	-21.9	Peak	Vertical
*	17396.5	47.5	5.9	53.4	68.2	-14.8	Peak	Vertical
	17974.5	48.1	6.8	54.9	74.0	-19.1	Peak	Vertical
	17974.5	32.5	6.8	39.3	54.0	-14.7	Average	Vertical

Note 1: "*" is not in restricted band, its limit is -27dBm/MHz. At a distance of 3 meters, the field strength limit in dB μ V/m can be determined by adding a "conversion" factor of 95.2dB to the EIRP limit of -27dBm/MHz to obtain the limit for out of band spurious emissions.

Note 2: Measure Level (dB μ V/m) = Reading Level (dB μ V) + Factor (dB)

Factor (dB) = Cable Loss (dB) + Antenna Factor (dB/m) - Pre_Amplifier Gain (dB)

Test Site	SIP-AC3	Test Engineer	Edward Zhang
Test Date	2021/02/25	Test Channel	140
Test Mode	802.11n-HT20(Beamforming mode)		
Remark	3. Average measurement was not performed if peak level lower than average limit. 4. Other frequency was 20dB below limit line within 1-18GHz, there is not show in the report.		

Mark	Frequency (MHz)	Reading Level (dB μ V)	Factor (dB)	Measure Level (dB μ V/m)	Limit (dB μ V/m)	Margin (dB)	Detector	Polarization
*	14226.0	48.5	2.0	50.5	68.2	-17.7	Peak	Horizontal
	16070.5	47.1	4.9	52.0	74.0	-22.0	Peak	Horizontal
*	17201.0	47.8	5.3	53.1	68.2	-15.1	Peak	Horizontal
	17983.0	46.7	6.8	53.5	74.0	-20.5	Peak	Horizontal
	17983.0	37.2	6.8	44.0	54.0	-10.0	Average	Horizontal
*	14260.0	48.6	1.9	50.5	68.2	-17.7	Peak	Vertical
	16155.5	47.4	5.1	52.5	74.0	-21.5	Peak	Vertical
*	16733.5	47.9	5.4	53.3	68.2	-14.9	Peak	Vertical
	17872.5	46.9	7.3	54.2	74.0	-19.8	Peak	Vertical
	17872.5	37.3	7.3	44.6	54.0	-9.4	Average	Vertical

Note 1: "*" is not in restricted band, its limit is -27dBm/MHz. At a distance of 3 meters, the field strength limit in dB μ V/m can be determined by adding a "conversion" factor of 95.2dB to the EIRP limit of -27dBm/MHz to obtain the limit for out of band spurious emissions.

Note 2: Measure Level (dB μ V/m) = Reading Level (dB μ V) + Factor (dB)

Factor (dB) = Cable Loss (dB) + Antenna Factor (dB/m) - Pre_Amplifier Gain (dB)

Test Site	SIP-AC3	Test Engineer	Edward Zhang
Test Date	2021/02/25	Test Channel	144
Test Mode	802.11n-HT20(Beamforming mode)		
Remark	3. Average measurement was not performed if peak level lower than average limit. 4. Other frequency was 20dB below limit line within 1-18GHz, there is not show in the report.		

Mark	Frequency (MHz)	Reading Level (dBμV)	Factor (dB)	Measure Level (dBμV/m)	Limit (dBμV/m)	Margin (dB)	Detector	Polarization
*	14226.0	48.0	2.0	50.0	68.2	-18.2	Peak	Horizontal
	15815.5	46.9	4.3	51.2	74.0	-22.8	Peak	Horizontal
*	16470.0	46.9	5.9	52.8	68.2	-15.4	Peak	Horizontal
	17719.5	47.7	6.6	54.3	74.0	-19.7	Peak	Horizontal
	17719.5	38.4	6.6	45.0	54.0	-9.0	Average	Horizontal
*	14302.5	49.0	1.8	50.8	68.2	-17.4	Peak	Vertical
	16045.0	47.0	4.9	51.9	74.0	-22.1	Peak	Vertical
*	16708.0	47.6	5.8	53.4	68.2	-14.8	Peak	Vertical
	17940.5	47.8	6.8	54.6	74.0	-19.4	Peak	Vertical
	17940.5	38.6	6.8	45.4	54.0	-8.6	Average	Vertical

Note 1: "*" is not in restricted band, its limit is -27dBm/MHz. At a distance of 3 meters, the field strength limit in dBμV/m can be determined by adding a "conversion" factor of 95.2dB to the EIRP limit of -27dBm/MHz to obtain the limit for out of band spurious emissions.

Note 2: Measure Level (dBμV/m) = Reading Level (dBμV) + Factor (dB)

Factor (dB) = Cable Loss (dB) + Antenna Factor (dB/m) - Pre_Amplifier Gain (dB)

Test Site	SIP-AC3	Test Engineer	Edward Zhang
Test Date	2021/02/25	Test Channel	54
Test Mode	802.11n-HT40(Beamforming mode)		
Remark	5. Average measurement was not performed if peak level lower than average limit. 6. Other frequency was 20dB below limit line within 1-18GHz, there is not show in the report.		

Mark	Frequency (MHz)	Reading Level (dBμV)	Factor (dB)	Measure Level (dBμV/m)	Limit (dBμV/m)	Margin (dB)	Detector	Polarization
	11999.0	50.3	-2.0	48.3	74.0	-25.7	Peak	Horizontal
*	13155.0	49.8	-1.6	48.2	68.2	-20.0	Peak	Horizontal
*	16572.0	47.5	5.3	52.8	68.2	-15.4	Peak	Horizontal
	17779.0	46.4	7.3	53.7	74.0	-20.3	Peak	Horizontal
	17779.0	37.8	7.3	45.1	54.0	-8.9	Average	Horizontal
	12305.0	50.1	-1.7	48.4	74.0	-25.6	Peak	Vertical
*	13750.0	48.7	0.7	49.4	68.2	-18.8	Peak	Vertical
*	16682.5	47.4	5.8	53.2	68.2	-15.0	Peak	Vertical
	17974.5	47.4	6.8	54.2	74.0	-19.8	Peak	Vertical
	17974.5	38.9	6.8	45.7	54.0	-8.3	Average	Vertical

Note 1: "*" is not in restricted band, its limit is -27dBm/MHz. At a distance of 3 meters, the field strength limit in dBμV/m can be determined by adding a "conversion" factor of 95.2dB to the EIRP limit of -27dBm/MHz to obtain the limit for out of band spurious emissions.

Note 2: Measure Level (dBμV/m) = Reading Level (dBμV) + Factor (dB)

Factor (dB) = Cable Loss (dB) + Antenna Factor (dB/m) - Pre_Amplifier Gain (dB)

Test Site	SIP-AC3	Test Engineer	Edward Zhang
Test Date	2021/02/25	Test Channel	62
Test Mode	802.11n-HT40(Beamforming mode)		
Remark	5. Average measurement was not performed if peak level lower than average limit. 6. Other frequency was 20dB below limit line within 1-18GHz, there is not show in the report.		

Mark	Frequency (MHz)	Reading Level (dBμV)	Factor (dB)	Measure Level (dBμV/m)	Limit (dBμV/m)	Margin (dB)	Detector	Polarization
*	14124.0	48.4	1.7	50.1	68.2	-18.1	Peak	Horizontal
	16147.0	47.0	5.2	52.2	74.0	-21.8	Peak	Horizontal
*	16708.0	46.7	5.8	52.5	68.2	-15.7	Peak	Horizontal
	17753.5	46.7	7.2	53.9	74.0	-20.1	Peak	Horizontal
	17753.5	37.2	7.2	44.4	54.0	-9.6	Average	Horizontal
*	14234.5	48.7	1.9	50.6	68.2	-17.6	Peak	Vertical
	15747.5	47.3	4.3	51.6	74.0	-22.4	Peak	Vertical
*	16699.5	47.1	5.8	52.9	68.2	-15.3	Peak	Vertical
	17872.5	46.7	7.3	54.0	74.0	-20.0	Peak	Vertical
	17872.5	36.2	7.3	43.5	54.0	-10.5	Average	Vertical

Note 1: "*" is not in restricted band, its limit is -27dBm/MHz. At a distance of 3 meters, the field strength limit in dBμV/m can be determined by adding a "conversion" factor of 95.2dB to the EIRP limit of -27dBm/MHz to obtain the limit for out of band spurious emissions.

Note 2: Measure Level (dBμV/m) = Reading Level (dBμV) + Factor (dB)

Factor (dB) = Cable Loss (dB) + Antenna Factor (dB/m) - Pre_Amplifier Gain (dB)

Test Site	SIP-AC3	Test Engineer	Edward Zhang
Test Date	2021/02/25	Test Channel	102
Test Mode	802.11n-HT40(Beamforming mode)		
Remark	5. Average measurement was not performed if peak level lower than average limit. 6. Other frequency was 20dB below limit line within 1-18GHz, there is not show in the report.		

Mark	Frequency (MHz)	Reading Level (dBμV)	Factor (dB)	Measure Level (dBμV/m)	Limit (dBμV/m)	Margin (dB)	Detector	Polarization
*	14243.0	48.8	1.8	50.6	68.2	-17.6	Peak	Horizontal
	15756.0	46.6	4.4	51.0	74.0	-23.0	Peak	Horizontal
*	17422.0	46.9	6.1	53.0	68.2	-15.2	Peak	Horizontal
	17932.0	46.9	7.1	54.0	74.0	-20.0	Peak	Horizontal
	17932.0	37.2	7.1	44.3	54.0	-9.7	Average	Horizontal
*	14132.5	48.4	1.8	50.2	68.2	-18.0	Peak	Vertical
	15747.5	46.5	4.3	50.8	74.0	-23.2	Peak	Vertical
*	16478.5	47.4	5.5	52.9	68.2	-15.3	Peak	Vertical
	17838.5	47.2	7.2	54.4	74.0	-19.6	Peak	Vertical
	17838.5	34.9	7.2	42.1	54.0	-11.9	Average	Vertical

Note 1: "*" is not in restricted band, its limit is -27dBm/MHz. At a distance of 3 meters, the field strength limit in dBμV/m can be determined by adding a "conversion" factor of 95.2dB to the EIRP limit of -27dBm/MHz to obtain the limit for out of band spurious emissions.

Note 2: Measure Level (dBμV/m) = Reading Level (dBμV) + Factor (dB)

Factor (dB) = Cable Loss (dB) + Antenna Factor (dB/m) - Pre_Amplifier Gain (dB)

Test Site	SIP-AC3	Test Engineer	Edward Zhang
Test Date	2021/02/25	Test Channel	110
Test Mode	802.11n-HT40(Beamforming mode)		
Remark	5. Average measurement was not performed if peak level lower than average limit. 6. Other frequency was 20dB below limit line within 1-18GHz, there is not show in the report.		

Mark	Frequency (MHz)	Reading Level (dBμV)	Factor (dB)	Measure Level (dBμV/m)	Limit (dBμV/m)	Margin (dB)	Detector	Polarization
*	14064.5	48.2	1.7	49.9	68.2	-18.3	Peak	Horizontal
	15798.5	47.5	3.9	51.4	74.0	-22.6	Peak	Horizontal
*	16512.5	48.2	5.0	53.2	68.2	-15.0	Peak	Horizontal
	18000.0	47.0	6.8	53.8	74.0	-20.2	Peak	Horizontal
	18000.0	35.9	6.8	42.7	54.0	-11.3	Average	Horizontal
*	14260.0	48.4	1.9	50.3	68.2	-17.9	Peak	Vertical
	16045.0	47.3	4.9	52.2	74.0	-21.8	Peak	Vertical
*	16699.5	46.7	5.8	52.5	68.2	-15.7	Peak	Vertical
	17804.5	46.8	7.1	53.9	74.0	-20.1	Peak	Vertical
	17804.5	37.5	7.1	44.6	54.0	-9.4	Average	Vertical

Note 1: "*" is not in restricted band, its limit is -27dBm/MHz. At a distance of 3 meters, the field strength limit in dBμV/m can be determined by adding a "conversion" factor of 95.2dB to the EIRP limit of -27dBm/MHz to obtain the limit for out of band spurious emissions.

Note 2: Measure Level (dBμV/m) = Reading Level (dBμV) + Factor (dB)

Factor (dB) = Cable Loss (dB) + Antenna Factor (dB/m) - Pre_Amplifier Gain (dB)

Test Site	SIP-AC3	Test Engineer	Edward Zhang
Test Date	2021/02/25	Test Channel	134
Test Mode	802.11n-HT40(Beamforming mode)		
Remark	5. Average measurement was not performed if peak level lower than average limit. 6. Other frequency was 20dB below limit line within 1-18GHz, there is not show in the report.		

Mark	Frequency (MHz)	Reading Level (dBμV)	Factor (dB)	Measure Level (dBμV/m)	Limit (dBμV/m)	Margin (dB)	Detector	Polarization
	12560.0	50.4	-2.0	48.4	74.0	-25.6	Peak	Horizontal
*	16470.0	47.4	5.9	53.3	68.2	-14.9	Peak	Horizontal
*	16793.0	47.5	5.5	53.0	68.2	-15.2	Peak	Horizontal
	17745.0	46.7	7.0	53.7	74.0	-20.3	Peak	Horizontal
	17745.0	38.9	7.0	45.9	54.0	-8.1	Average	Horizontal
*	14948.5	48.0	2.8	50.8	68.2	-17.4	Peak	Vertical
	15943.0	48.2	4.1	52.3	74.0	-21.7	Peak	Vertical
*	16691.0	47.1	5.7	52.8	68.2	-15.4	Peak	Vertical
	17779.0	46.8	7.3	54.1	74.0	-19.9	Peak	Vertical
	17779.0	38.7	7.3	46.0	54.0	-8.0	Average	Horizontal

Note 1: "*" is not in restricted band, its limit is -27dBm/MHz. At a distance of 3 meters, the field strength limit in dBμV/m can be determined by adding a "conversion" factor of 95.2dB to the EIRP limit of -27dBm/MHz to obtain the limit for out of band spurious emissions.

Note 2: Measure Level (dBμV/m) = Reading Level (dBμV) + Factor (dB)

Factor (dB) = Cable Loss (dB) + Antenna Factor (dB/m) - Pre_Amplifier Gain (dB)

Test Site	SIP-AC3	Test Engineer	Edward Zhang
Test Date	2021/02/25	Test Channel	142
Test Mode	802.11n-HT40(Beamforming mode)		
Remark	5. Average measurement was not performed if peak level lower than average limit. 6. Other frequency was 20dB below limit line within 1-18GHz, there is not show in the report.		

Mark	Frequency (MHz)	Reading Level (dBμV)	Factor (dB)	Measure Level (dBμV/m)	Limit (dBμV/m)	Margin (dB)	Detector	Polarization
*	14447.0	48.7	2.1	50.8	68.2	-17.4	Peak	Horizontal
	16062.0	47.0	5.2	52.2	74.0	-21.8	Peak	Horizontal
*	16759.0	47.0	5.5	52.5	68.2	-15.7	Peak	Horizontal
	17745.0	47.5	7.0	54.5	74.0	-19.5	Peak	Horizontal
	17745.0	38.2	7.0	45.2	54.0	-8.8	Average	Horizontal
	15909.0	47.4	4.2	51.6	74.0	-22.4	Peak	Vertical
*	16470.0	46.8	5.9	52.7	68.2	-15.5	Peak	Vertical
*	17379.5	46.9	6.0	52.9	68.2	-15.3	Peak	Vertical
	17787.5	47.7	7.2	54.9	74.0	-19.1	Peak	Vertical
	17787.5	38.4	7.2	45.6	54.0	-8.4	Average	Vertical

Note 1: "*" is not in restricted band, its limit is -27dBm/MHz. At a distance of 3 meters, the field strength limit in dBμV/m can be determined by adding a "conversion" factor of 95.2dB to the EIRP limit of -27dBm/MHz to obtain the limit for out of band spurious emissions.

Note 2: Measure Level (dBμV/m) = Reading Level (dBμV) + Factor (dB)

Factor (dB) = Cable Loss (dB) + Antenna Factor (dB/m) - Pre_Amplifier Gain (dB)

Test Site	SIP-AC3	Test Engineer	Edward Zhang
Test Date	2021/02/25	Test Channel	52
Test Mode	802.11ac-VHT20(Beamforming mode)		
Remark	3. Average measurement was not performed if peak level lower than average limit. 4. Other frequency was 20dB below limit line within 1-18GHz, there is not show in the report.		

Mark	Frequency (MHz)	Reading Level (dBμV)	Factor (dB)	Measure Level (dBμV/m)	Limit (dBμV/m)	Margin (dB)	Detector	Polarization
*	14294.0	49.0	1.8	50.8	68.2	-17.4	Peak	Horizontal
	16087.5	47.5	4.3	51.8	74.0	-22.2	Peak	Horizontal
*	16504.0	47.2	5.3	52.5	68.2	-15.7	Peak	Horizontal
	17711.0	47.8	6.4	54.2	74.0	-19.8	Peak	Horizontal
	17711.0	38.5	6.4	44.9	54.0	-9.1	Average	Horizontal
*	14141.0	48.4	1.9	50.3	68.2	-17.9	Peak	Vertical
	15739.0	47.7	4.2	51.9	74.0	-22.1	Peak	Vertical
*	16470.0	47.0	5.9	52.9	68.2	-15.3	Peak	Vertical
	17847.0	47.0	7.0	54.0	74.0	-20.0	Peak	Vertical
	17847.0	38.7	7.0	45.7	54.0	-8.3	Average	Vertical

Note 1: "*" is not in restricted band, its limit is -27dBm/MHz. At a distance of 3 meters, the field strength limit in dBμV/m can be determined by adding a "conversion" factor of 95.2dB to the EIRP limit of -27dBm/MHz to obtain the limit for out of band spurious emissions.

Note 2: Measure Level (dBμV/m) = Reading Level (dBμV) + Factor (dB)

Factor (dB) = Cable Loss (dB) + Antenna Factor (dB/m) - Pre_Amplifier Gain (dB)

Test Site	SIP-AC3	Test Engineer	Edward Zhang
Test Date	2021/02/25	Test Channel	60
Test Mode	802.11ac-VHT20(Beamforming mode)		
Remark	3. Average measurement was not performed if peak level lower than average limit. 4. Other frequency was 20dB below limit line within 1-18GHz, there is not show in the report.		

Mark	Frequency (MHz)	Reading Level (dBμV)	Factor (dB)	Measure Level (dBμV/m)	Limit (dBμV/m)	Margin (dB)	Detector	Polarization
*	15237.5	47.7	3.1	50.8	68.2	-17.4	Peak	Horizontal
	15960.0	47.4	4.5	51.9	74.0	-22.1	Peak	Horizontal
*	16818.5	47.8	5.3	53.1	68.2	-15.1	Peak	Horizontal
	17991.5	47.8	6.8	54.6	74.0	-19.4	Peak	Horizontal
	17991.5	38.5	6.8	45.3	54.0	-8.7	Average	Horizontal
*	14515.0	48.2	2.4	50.6	68.2	-17.6	Peak	Vertical
	15535.0	48.0	3.8	51.8	74.0	-22.2	Peak	Vertical
*	16716.5	47.0	5.7	52.7	68.2	-15.5	Peak	Vertical
	17889.5	47.1	7.2	54.3	74.0	-19.7	Peak	Vertical
	17889.5	38.5	7.2	45.7	54.0	-8.3	Average	Vertical

Note 1: "*" is not in restricted band, its limit is -27dBm/MHz. At a distance of 3 meters, the field strength limit in dBμV/m can be determined by adding a "conversion" factor of 95.2dB to the EIRP limit of -27dBm/MHz to obtain the limit for out of band spurious emissions.

Note 2: Measure Level (dBμV/m) = Reading Level (dBμV) + Factor (dB)

Factor (dB) = Cable Loss (dB) + Antenna Factor (dB/m) - Pre_Amplifier Gain (dB)

Test Site	SIP-AC3	Test Engineer	Edward Zhang
Test Date	2021/02/25	Test Channel	64
Test Mode	802.11ac-VHT20(Beamforming mode)		
Remark	3. Average measurement was not performed if peak level lower than average limit. 4. Other frequency was 20dB below limit line within 1-18GHz, there is not show in the report.		

Mark	Frequency (MHz)	Reading Level (dBμV)	Factor (dB)	Measure Level (dBμV/m)	Limit (dBμV/m)	Margin (dB)	Detector	Polarization
*	14022.0	48.7	1.2	49.9	68.2	-18.3	Peak	Horizontal
	15747.5	47.0	4.3	51.3	74.0	-22.7	Peak	Horizontal
*	16793.0	47.2	5.5	52.7	68.2	-15.5	Peak	Horizontal
	17745.0	46.7	7.0	53.7	74.0	-20.3	Peak	Horizontal
	17745.0	37.6	7.0	44.6	54.0	-9.4	Average	Horizontal
	12279.5	50.6	-2.2	48.4	74.0	-25.6	Peak	Vertical
*	14158.0	48.6	1.9	50.5	68.2	-17.7	Peak	Vertical
*	16691.0	46.7	5.7	52.4	68.2	-15.8	Peak	Vertical
	17779.0	46.7	7.3	54.0	74.0	-20.0	Peak	Vertical
	14022.0	48.7	1.2	49.9	68.2	-18.3	Average	Vertical

Note 1: "*" is not in restricted band, its limit is -27dBm/MHz. At a distance of 3 meters, the field strength limit in dBμV/m can be determined by adding a "conversion" factor of 95.2dB to the EIRP limit of -27dBm/MHz to obtain the limit for out of band spurious emissions.

Note 2: Measure Level (dBμV/m) = Reading Level (dBμV) + Factor (dB)

Factor (dB) = Cable Loss (dB) + Antenna Factor (dB/m) - Pre_Amplifier Gain (dB)

Test Site	SIP-AC3	Test Engineer	Edward Zhang
Test Date	2021/02/25	Test Channel	100
Test Mode	802.11ac-VHT20(Beamforming mode)		
Remark	3. Average measurement was not performed if peak level lower than average limit. 4. Other frequency was 20dB below limit line within 1-18GHz, there is not show in the report.		

Mark	Frequency (MHz)	Reading Level (dB μ V)	Factor (dB)	Measure Level (dB μ V/m)	Limit (dB μ V/m)	Margin (dB)	Detector	Polarization
	12203.0	50.3	-2.0	48.3	74.0	-25.7	Peak	Horizontal
*	15203.5	47.4	2.8	50.2	68.2	-18.0	Peak	Horizontal
*	16623.0	47.5	5.0	52.5	68.2	-15.7	Peak	Horizontal
	17889.5	47.1	7.2	54.3	74.0	-19.7	Peak	Horizontal
	17889.5	37.5	7.2	44.7	54.0	-9.3	Average	Horizontal
*	13852.0	48.9	1.0	49.9	68.2	-18.3	Peak	Vertical
	16164.0	48.5	5.0	53.5	74.0	-20.5	Peak	Vertical
*	16793.0	47.8	5.5	53.3	68.2	-14.9	Peak	Vertical
	17872.5	47.6	7.3	54.9	74.0	-19.1	Peak	Vertical
	17872.5	38.9	7.3	46.2	54.0	-7.8	Average	Vertical

Note 1: "*" is not in restricted band, its limit is -27dBm/MHz. At a distance of 3 meters, the field strength limit in dB μ V/m can be determined by adding a "conversion" factor of 95.2dB to the EIRP limit of -27dBm/MHz to obtain the limit for out of band spurious emissions.

Note 2: Measure Level (dB μ V/m) = Reading Level (dB μ V) + Factor (dB)

Factor (dB) = Cable Loss (dB) + Antenna Factor (dB/m) - Pre_Amplifier Gain (dB)

Test Site	SIP-AC3	Test Engineer	Edward Zhang
Test Date	2021/02/25	Test Channel	116
Test Mode	802.11ac-VHT20(Beamforming mode)		
Remark	3. Average measurement was not performed if peak level lower than average limit. 4. Other frequency was 20dB below limit line within 1-18GHz, there is not show in the report.		

Mark	Frequency (MHz)	Reading Level (dBμV)	Factor (dB)	Measure Level (dBμV/m)	Limit (dBμV/m)	Margin (dB)	Detector	Polarization
*	14540.5	48.3	2.6	50.9	68.2	-17.3	Peak	Horizontal
	15739.0	47.9	4.2	52.1	74.0	-21.9	Peak	Horizontal
*	16742.0	47.1	5.4	52.5	68.2	-15.7	Peak	Horizontal
	17719.5	47.2	6.6	53.8	74.0	-20.2	Peak	Horizontal
	17719.5	38.7	6.6	45.3	54.0	-8.7	Average	Horizontal
	15756.0	47.2	4.4	51.6	74.0	-22.4	Peak	Vertical
*	16470.0	46.8	5.9	52.7	68.2	-15.5	Peak	Vertical
*	17456.0	47.7	5.6	53.3	68.2	-14.9	Peak	Vertical
	18000.0	46.6	6.8	53.4	74.0	-20.6	Peak	Vertical
	18000.0	37.5	6.8	44.3	54.0	-9.7	Average	Vertical

Note 1: "*" is not in restricted band, its limit is -27dBm/MHz. At a distance of 3 meters, the field strength limit in dBμV/m can be determined by adding a "conversion" factor of 95.2dB to the EIRP limit of -27dBm/MHz to obtain the limit for out of band spurious emissions.

Note 2: Measure Level (dBμV/m) = Reading Level (dBμV) + Factor (dB)

Factor (dB) = Cable Loss (dB) + Antenna Factor (dB/m) - Pre_Amplifier Gain (dB)

Test Site	SIP-AC3	Test Engineer	Edward Zhang
Test Date	2021/02/25	Test Channel	140
Test Mode	802.11ac-VHT20(Beamforming mode)		
Remark	3. Average measurement was not performed if peak level lower than average limit. 4. Other frequency was 20dB below limit line within 1-18GHz, there is not show in the report.		

Mark	Frequency (MHz)	Reading Level (dBμV)	Factor (dB)	Measure Level (dBμV/m)	Limit (dBμV/m)	Margin (dB)	Detector	Polarization
	12033.0	50.7	-2.5	48.2	74.0	-25.8	Peak	Horizontal
	15594.5	47.8	3.4	51.2	74.0	-22.8	Peak	Horizontal
*	17379.5	47.2	6.0	53.2	68.2	-15.0	Peak	Horizontal
*	17694.0	46.5	6.9	53.4	68.2	-14.8	Peak	Horizontal
*	14302.5	48.4	1.8	50.2	68.2	-18.0	Peak	Vertical
	16045.0	47.7	4.9	52.6	74.0	-21.4	Peak	Vertical
*	16614.5	47.1	5.0	52.1	68.2	-16.1	Peak	Vertical
	17762.0	46.7	7.3	54.0	74.0	-20.0	Peak	Vertical
	17762.0	38.7	7.3	46.0	54.0	-8.0	Average	Vertical

Note 1: "*" is not in restricted band, its limit is -27dBm/MHz. At a distance of 3 meters, the field strength limit in dBμV/m can be determined by adding a "conversion" factor of 95.2dB to the EIRP limit of -27dBm/MHz to obtain the limit for out of band spurious emissions.

Note 2: Measure Level (dBμV/m) = Reading Level (dBμV) + Factor (dB)

Factor (dB) = Cable Loss (dB) + Antenna Factor (dB/m) - Pre_Amplifier Gain (dB)

Test Site	SIP-AC3	Test Engineer	Edward Zhang
Test Date	2021/02/25	Test Channel	144
Test Mode	802.11ac-VHT20(Beamforming mode)		
Remark	3. Average measurement was not performed if peak level lower than average limit. 4. Other frequency was 20dB below limit line within 1-18GHz, there is not show in the report.		

Mark	Frequency (MHz)	Reading Level (dBμV)	Factor (dB)	Measure Level (dBμV/m)	Limit (dBμV/m)	Margin (dB)	Detector	Polarization
*	14268.5	48.9	1.9	50.8	68.2	-17.4	Peak	Horizontal
	16053.5	47.2	5.0	52.2	74.0	-21.8	Peak	Horizontal
*	16708.0	46.9	5.8	52.7	68.2	-15.5	Peak	Horizontal
	17966.0	48.1	6.8	54.9	74.0	-19.1	Peak	Horizontal
	17966.0	40.3	6.8	47.1	54.0	-6.9	Average	Horizontal
*	13733.0	48.5	0.6	49.1	68.2	-19.1	Peak	Vertical
	14481.0	48.1	2.2	50.3	74.0	-23.7	Peak	Vertical
*	16844.0	47.0	5.4	52.4	68.2	-15.8	Peak	Vertical
	17881.0	46.5	7.2	53.7	74.0	-20.3	Peak	Vertical
	17881.0	37.6	7.2	44.8	54.0	-9.2	Average	Vertical

Note 1: "*" is not in restricted band, its limit is -27dBm/MHz. At a distance of 3 meters, the field strength limit in dBμV/m can be determined by adding a "conversion" factor of 95.2dB to the EIRP limit of -27dBm/MHz to obtain the limit for out of band spurious emissions.

Note 2: Measure Level (dBμV/m) = Reading Level (dBμV) + Factor (dB)

Factor (dB) = Cable Loss (dB) + Antenna Factor (dB/m) - Pre_Amplifier Gain (dB)

Test Site	SIP-AC3	Test Engineer	Edward Zhang
Test Date	2021/02/25	Test Channel	54
Test Mode	802.11ac-VHT40(Beamforming mode)		
Remark	7. Average measurement was not performed if peak level lower than average limit. 8. Other frequency was 20dB below limit line within 1-18GHz, there is not show in the report.		

Mark	Frequency (MHz)	Reading Level (dB μ V)	Factor (dB)	Measure Level (dB μ V/m)	Limit (dB μ V/m)	Margin (dB)	Detector	Polarization
*	14625.5	47.1	2.8	49.9	68.2	-18.3	Peak	Horizontal
	16053.5	46.7	5.0	51.7	74.0	-22.3	Peak	Horizontal
*	16393.5	47.5	5.5	53.0	68.2	-15.2	Peak	Horizontal
	17770.5	47.9	7.3	55.2	74.0	-18.8	Peak	Horizontal
	17770.5	38.7	7.3	46.0	54.0	-8.0	Average	Horizontal
*	14617.0	47.7	2.8	50.5	68.2	-17.7	Peak	Vertical
	16053.5	47.4	5.0	52.4	74.0	-21.6	Peak	Vertical
*	17201.0	47.4	5.3	52.7	68.2	-15.5	Peak	Vertical
	17804.5	47.4	7.1	54.5	74.0	-19.5	Peak	Vertical
	17804.5	38.9	7.1	46.0	54.0	-8.0	Average	Vertical

Note 1: "*" is not in restricted band, its limit is -27dBm/MHz. At a distance of 3 meters, the field strength limit in dB μ V/m can be determined by adding a "conversion" factor of 95.2dB to the EIRP limit of -27dBm/MHz to obtain the limit for out of band spurious emissions.

Note 2: Measure Level (dB μ V/m) = Reading Level (dB μ V) + Factor (dB)

Factor (dB) = Cable Loss (dB) + Antenna Factor (dB/m) - Pre_Amplifier Gain (dB)

Test Site	SIP-AC3	Test Engineer	Edward Zhang
Test Date	2021/02/25	Test Channel	62
Test Mode	802.11ac-VHT40(Beamforming mode)		
Remark	7. Average measurement was not performed if peak level lower than average limit. 8. Other frequency was 20dB below limit line within 1-18GHz, there is not show in the report.		

Mark	Frequency (MHz)	Reading Level (dBμV)	Factor (dB)	Measure Level (dBμV/m)	Limit (dBμV/m)	Margin (dB)	Detector	Polarization
*	14217.5	48.1	1.9	50.0	68.2	-18.2	Peak	Horizontal
	16155.5	47.1	5.1	52.2	74.0	-21.8	Peak	Horizontal
*	16504.0	47.0	5.3	52.3	68.2	-15.9	Peak	Horizontal
	17736.5	47.9	6.9	54.8	74.0	-19.2	Peak	Horizontal
	17736.5	39.7	6.9	46.6	54.0	-7.4	Average	Horizontal
*	14047.5	48.7	1.6	50.3	68.2	-17.9	Peak	Vertical
	15824.0	47.0	4.5	51.5	74.0	-22.5	Peak	Vertical
*	16385.0	46.9	5.5	52.4	68.2	-15.8	Peak	Vertical
	17889.5	47.2	7.2	54.4	74.0	-19.6	Peak	Vertical
	17889.5	34.9	7.2	42.1	54.0	-11.9	Average	Vertical

Note 1: "*" is not in restricted band, its limit is -27dBm/MHz. At a distance of 3 meters, the field strength limit in dBμV/m can be determined by adding a "conversion" factor of 95.2dB to the EIRP limit of -27dBm/MHz to obtain the limit for out of band spurious emissions.

Note 2: Measure Level (dBμV/m) = Reading Level (dBμV) + Factor (dB)

Factor (dB) = Cable Loss (dB) + Antenna Factor (dB/m) - Pre_Amplifier Gain (dB)

Test Site	SIP-AC3	Test Engineer	Edward Zhang
Test Date	2021/02/25	Test Channel	102
Test Mode	802.11ac-VHT40(Beamforming mode)		
Remark	7. Average measurement was not performed if peak level lower than average limit. 8. Other frequency was 20dB below limit line within 1-18GHz, there is not show in the report.		

Mark	Frequency (MHz)	Reading Level (dBμV)	Factor (dB)	Measure Level (dBμV/m)	Limit (dBμV/m)	Margin (dB)	Detector	Polarization
*	15050.5	47.5	3.0	50.5	68.2	-17.7	Peak	Horizontal
	16045.0	47.0	4.9	51.9	74.0	-22.1	Peak	Horizontal
*	16674.0	47.2	5.8	53.0	68.2	-15.2	Peak	Horizontal
	17991.5	46.8	6.8	53.6	74.0	-20.4	Peak	Horizontal
	17991.5	36.5	6.8	43.3	54.0	-10.7	Average	Horizontal
	12084.0	50.2	-2.2	48.0	74.0	-26.0	Peak	Vertical
*	14506.5	48.5	2.4	50.9	68.2	-17.3	Peak	Vertical
*	16716.5	47.0	5.7	52.7	68.2	-15.5	Peak	Vertical
	17745.0	46.6	7.0	53.6	74.0	-20.4	Peak	Vertical

Note 1: "*" is not in restricted band, its limit is -27dBm/MHz. At a distance of 3 meters, the field strength limit in dBμV/m can be determined by adding a "conversion" factor of 95.2dB to the EIRP limit of -27dBm/MHz to obtain the limit for out of band spurious emissions.

Note 2: Measure Level (dBμV/m) = Reading Level (dBμV) + Factor (dB)

Factor (dB) = Cable Loss (dB) + Antenna Factor (dB/m) - Pre_Amplifier Gain (dB)

Test Site	SIP-AC3	Test Engineer	Edward Zhang
Test Date	2021/02/25	Test Channel	110
Test Mode	802.11ac-VHT40(Beamforming mode)		
Remark	7. Average measurement was not performed if peak level lower than average limit. 8. Other frequency was 20dB below limit line within 1-18GHz, there is not show in the report.		

Mark	Frequency (MHz)	Reading Level (dB μ V)	Factor (dB)	Measure Level (dB μ V/m)	Limit (dB μ V/m)	Margin (dB)	Detector	Polarization
*	14149.5	48.3	1.9	50.2	68.2	-18.0	Peak	Horizontal
	16053.5	46.8	5.0	51.8	74.0	-22.2	Peak	Horizontal
*	16495.5	47.1	5.2	52.3	68.2	-15.9	Peak	Horizontal
	17779.0	47.7	7.3	55.0	74.0	-19.0	Peak	Horizontal
	17779.0	37.5	7.3	44.8	54.0	-9.2	Average	Horizontal
*	14685.0	47.7	2.6	50.3	68.2	-17.9	Peak	Vertical
	16053.5	47.1	5.0	52.1	74.0	-21.9	Peak	Vertical
*	16359.5	47.3	5.1	52.4	68.2	-15.8	Peak	Vertical
	17855.5	46.4	7.2	53.6	74.0	-20.4	Peak	Vertical
	17855.5	39.7	7.2	46.9	54.0	-7.1	Average	Vertical

Note 1: "*" is not in restricted band, its limit is -27dBm/MHz. At a distance of 3 meters, the field strength limit in dB μ V/m can be determined by adding a "conversion" factor of 95.2dB to the EIRP limit of -27dBm/MHz to obtain the limit for out of band spurious emissions.

Note 2: Measure Level (dB μ V/m) = Reading Level (dB μ V) + Factor (dB)

Factor (dB) = Cable Loss (dB) + Antenna Factor (dB/m) - Pre_Amplifier Gain (dB)

Test Site	SIP-AC3	Test Engineer	Edward Zhang
Test Date	2021/02/25	Test Channel	134
Test Mode	802.11ac-VHT40(Beamforming mode)		
Remark	7. Average measurement was not performed if peak level lower than average limit. 8. Other frequency was 20dB below limit line within 1-18GHz, there is not show in the report.		

Mark	Frequency (MHz)	Reading Level (dBμV)	Factor (dB)	Measure Level (dBμV/m)	Limit (dBμV/m)	Margin (dB)	Detector	Polarization
	11642.0	50.5	-4.3	46.2	74.0	-27.8	Peak	Horizontal
*	15118.5	49.4	0.8	50.2	68.2	-18.0	Peak	Horizontal
*	16733.5	47.8	4.2	52.0	68.2	-16.2	Peak	Horizontal
	17804.5	46.8	5.9	52.7	74.0	-21.3	Peak	Horizontal
	11973.5	50.0	-3.9	46.1	74.0	-27.9	Peak	Vertical
*	13818.0	49.2	-0.9	48.3	68.2	-19.9	Peak	Vertical
*	17371.0	47.5	5.2	52.7	68.2	-15.5	Peak	Vertical
	17745.0	47.7	5.8	53.5	74.0	-20.5	Peak	Vertical

Note 1: "*" is not in restricted band, its limit is -27dBm/MHz. At a distance of 3 meters, the field strength limit in dBμV/m can be determined by adding a "conversion" factor of 95.2dB to the EIRP limit of -27dBm/MHz to obtain the limit for out of band spurious emissions.

Note 2: Measure Level (dBμV/m) = Reading Level (dBμV) + Factor (dB)

Factor (dB) = Cable Loss (dB) + Antenna Factor (dB/m) - Pre_Amplifier Gain (dB)

Test Site	SIP-AC3	Test Engineer	Edward Zhang
Test Date	2021/02/25	Test Channel	142
Test Mode	802.11ac-VHT40(Beamforming mode)		
Remark	7. Average measurement was not performed if peak level lower than average limit. 8. Other frequency was 20dB below limit line within 1-18GHz, there is not show in the report.		

Mark	Frequency (MHz)	Reading Level (dB μ V)	Factor (dB)	Measure Level (dB μ V/m)	Limit (dB μ V/m)	Margin (dB)	Detector	Polarization
	11395.5	54.6	-5.0	49.6	74.0	-24.4	Peak	Horizontal
*	14030.5	49.2	-0.6	48.6	68.2	-19.6	Peak	Horizontal
*	16742.0	48.3	4.2	52.5	68.2	-15.7	Peak	Horizontal
	17940.5	47.0	5.9	52.9	74.0	-21.1	Peak	Horizontal
	12441.0	50.1	-3.8	46.3	74.0	-27.7	Peak	Vertical
*	14846.5	48.6	0.8	49.4	68.2	-18.8	Peak	Vertical
*	16767.5	47.9	4.1	52.0	68.2	-16.2	Peak	Vertical
	17796.0	47.2	6.1	53.3	74.0	-20.7	Peak	Vertical

Note 1: "*" is not in restricted band, its limit is -27dBm/MHz. At a distance of 3 meters, the field strength limit in dB μ V/m can be determined by adding a "conversion" factor of 95.2dB to the EIRP limit of -27dBm/MHz to obtain the limit for out of band spurious emissions.

Note 2: Measure Level (dB μ V/m) = Reading Level (dB μ V) + Factor (dB)

Factor (dB) = Cable Loss (dB) + Antenna Factor (dB/m) - Pre_Amplifier Gain (dB)

Test Site	SIP-AC3	Test Engineer	Edward Zhang
Test Date	2021/02/25	Test Channel	58
Test Mode	802.11ac-VHT80(Beamforming mode)		
Remark	3. Average measurement was not performed if peak level lower than average limit. 4. Other frequency was 20dB below limit line within 1-18GHz, there is not show in the report.		

Mark	Frequency (MHz)	Reading Level (dBμV)	Factor (dB)	Measure Level (dBμV/m)	Limit (dBμV/m)	Margin (dB)	Detector	Polarization
	11540.0	51.7	-4.7	47.0	74.0	-27.0	Peak	Horizontal
*	15271.5	48.7	1.0	49.7	68.2	-18.5	Peak	Horizontal
*	16835.5	47.9	4.3	52.2	68.2	-16.0	Peak	Horizontal
	17983.0	47.4	5.7	53.1	74.0	-20.9	Peak	Horizontal
	8463.0	56.1	-6.1	50.0	74.0	-24.0	Peak	Vertical
*	14761.5	49.2	0.8	50.0	68.2	-18.2	Peak	Vertical
*	16835.5	47.5	4.3	51.8	68.2	-16.4	Peak	Vertical
	17804.5	47.2	5.9	53.1	74.0	-20.9	Peak	Vertical

Note 1: "*" is not in restricted band, its limit is -27dBm/MHz. At a distance of 3 meters, the field strength limit in dBμV/m can be determined by adding a "conversion" factor of 95.2dB to the EIRP limit of -27dBm/MHz to obtain the limit for out of band spurious emissions.

Note 2: Measure Level (dBμV/m) = Reading Level (dBμV) + Factor (dB)

Factor (dB) = Cable Loss (dB) + Antenna Factor (dB/m) - Pre_Amplifier Gain (dB)

Test Site	SIP-AC3	Test Engineer	Edward Zhang
Test Date	2021/02/25	Test Channel	106
Test Mode	802.11ac-VHT80(Beamforming mode)		
Remark	3. Average measurement was not performed if peak level lower than average limit. 4. Other frequency was 20dB below limit line within 1-18GHz, there is not show in the report.		

Mark	Frequency (MHz)	Reading Level (dB μ V)	Factor (dB)	Measure Level (dB μ V/m)	Limit (dB μ V/m)	Margin (dB)	Detector	Polarization
	11931.0	50.8	-4.1	46.7	74.0	-27.3	Peak	Horizontal
*	14719.0	49.2	0.3	49.5	68.2	-18.7	Peak	Horizontal
*	16708.0	48.0	4.0	52.0	68.2	-16.2	Peak	Horizontal
	17728.0	47.9	5.4	53.3	74.0	-20.7	Peak	Horizontal
	11676.0	50.3	-4.5	45.8	74.0	-28.2	Peak	Vertical
*	14617.0	49.5	0.3	49.8	68.2	-18.4	Peak	Vertical
*	16869.5	47.9	4.2	52.1	68.2	-16.1	Peak	Vertical
	17915.0	47.6	5.9	53.5	74.0	-20.5	Peak	Vertical

Note 1: "*" is not in restricted band, its limit is -27dBm/MHz. At a distance of 3 meters, the field strength limit in dB μ V/m can be determined by adding a "conversion" factor of 95.2dB to the EIRP limit of -27dBm/MHz to obtain the limit for out of band spurious emissions.

Note 2: Measure Level (dB μ V/m) = Reading Level (dB μ V) + Factor (dB)

Factor (dB) = Cable Loss (dB) + Antenna Factor (dB/m) - Pre_Amplifier Gain (dB)

Test Site	SIP-AC3	Test Engineer	Edward Zhang
Test Date	2021/02/25	Test Channel	122
Test Mode	802.11ac-VHT80(Beamforming mode)		
Remark	3. Average measurement was not performed if peak level lower than average limit. 4. Other frequency was 20dB below limit line within 1-18GHz, there is not show in the report.		

Mark	Frequency (MHz)	Reading Level (dBμV)	Factor (dB)	Measure Level (dBμV/m)	Limit (dBμV/m)	Margin (dB)	Detector	Polarization
	12271.0	50.1	-3.6	46.5	74.0	-27.5	Peak	Horizontal
*	14642.5	48.7	0.6	49.3	68.2	-18.9	Peak	Horizontal
*	16699.5	48.4	3.9	52.3	68.2	-15.9	Peak	Horizontal
	17753.5	47.8	5.5	53.3	74.0	-20.7	Peak	Horizontal
*	14668.0	48.2	0.7	48.9	68.2	-19.3	Peak	Vertical
	15679.5	47.9	1.9	49.8	74.0	-24.2	Peak	Vertical
*	16742.0	47.7	4.2	51.9	68.2	-16.3	Peak	Vertical
	17753.5	47.1	5.5	52.6	74.0	-21.4	Peak	Vertical

Note 1: "*" is not in restricted band, its limit is -27dBm/MHz. At a distance of 3 meters, the field strength limit in dBμV/m can be determined by adding a "conversion" factor of 95.2dB to the EIRP limit of -27dBm/MHz to obtain the limit for out of band spurious emissions.

Note 2: Measure Level (dBμV/m) = Reading Level (dBμV) + Factor (dB)

Factor (dB) = Cable Loss (dB) + Antenna Factor (dB/m) - Pre_Amplifier Gain (dB)

Test Site	SIP-AC3	Test Engineer	Edward Zhang
Test Date	2021/02/25	Test Channel	138
Test Mode	802.11ac-VHT80(Beamforming mode)		
Remark	3. Average measurement was not performed if peak level lower than average limit. 4. Other frequency was 20dB below limit line within 1-18GHz, there is not show in the report.		

Mark	Frequency (MHz)	Reading Level (dBμV)	Factor (dB)	Measure Level (dBμV/m)	Limit (dBμV/m)	Margin (dB)	Detector	Polarization
*	14778.5	49.3	0.6	49.9	68.2	-18.3	Peak	Horizontal
	15747.5	48.2	2.4	50.6	74.0	-23.4	Peak	Horizontal
*	17371.0	48.3	5.2	53.5	68.2	-14.7	Peak	Horizontal
	17906.5	47.0	6.0	53.0	74.0	-21.0	Peak	Horizontal
*	14957.0	49.1	0.8	49.9	68.2	-18.3	Peak	Vertical
	15764.5	47.6	2.7	50.3	74.0	-23.7	Peak	Vertical
*	17065.0	48.7	3.8	52.5	68.2	-15.7	Peak	Vertical
	17728.0	48.9	5.4	54.3	74.0	-19.7	Peak	Vertical

Note 1: "*" is not in restricted band, its limit is -27dBm/MHz. At a distance of 3 meters, the field strength limit in dBμV/m can be determined by adding a "conversion" factor of 95.2dB to the EIRP limit of -27dBm/MHz to obtain the limit for out of band spurious emissions.

Note 2: Measure Level (dBμV/m) = Reading Level (dBμV) + Factor (dB)

Factor (dB) = Cable Loss (dB) + Antenna Factor (dB/m) - Pre_Amplifier Gain (dB)

The Result of Radiated Emission below 1GHz:

Site: SIP-AC3	Time: 2021/03/17 - 20:17
Limit: FCC_Part15.209_RSE(3m)	Engineer: White Wang
Probe: SIP-AC3_VULB 9168 _30-1500MHz	Polarity: Horizontal
EUT: Dual Band ONT	Power: AC 120V/60Hz
Test Mode: Transmit by 802.11a at channel 5320MHz	

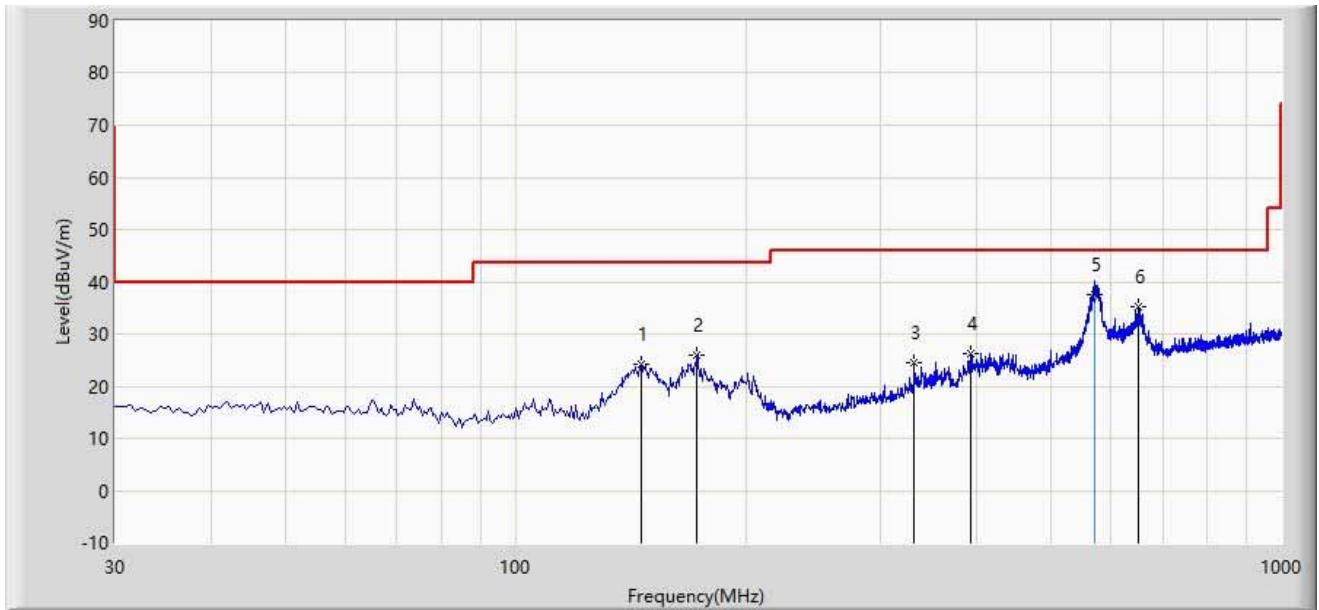

No	Flag	Mark	Frequency (MHz)	Measure Level (dBuV/m)	Reading Level (dBuV)	Margin (dB)	Limit (dBuV/m)	Factor (dB)	Type
1			145.915	24.126	6.066	-19.374	43.500	18.060	PK
2			172.590	25.926	8.753	-17.574	43.500	17.173	PK
3			331.670	24.558	5.203	-21.442	46.000	19.355	PK
4			393.750	26.095	5.494	-19.905	46.000	20.601	PK
5		*	571.745	37.627	13.200	-8.373	46.000	24.426	QP
6			651.770	35.203	9.181	-10.797	46.000	26.022	PK

Note: Measure Level (dBμV/m) = Reading Level (dBμV) + Factor (dB)

Factor (dB) = Cable Loss (dB) + Antenna Factor (dB/m)

Site: SIP-AC3	Time: 2021/03/17 - 20:21
Limit: FCC_Part15.209_RSE(3m)	Engineer: White Wang
Probe: SIP-AC3_VULB 9168 _30-1500MHz	Polarity: Vertical
EUT: Dual Band ONT	Power: AC 120V/60Hz
Test Mode: Transmit by 802.11a at channel 5320MHz	

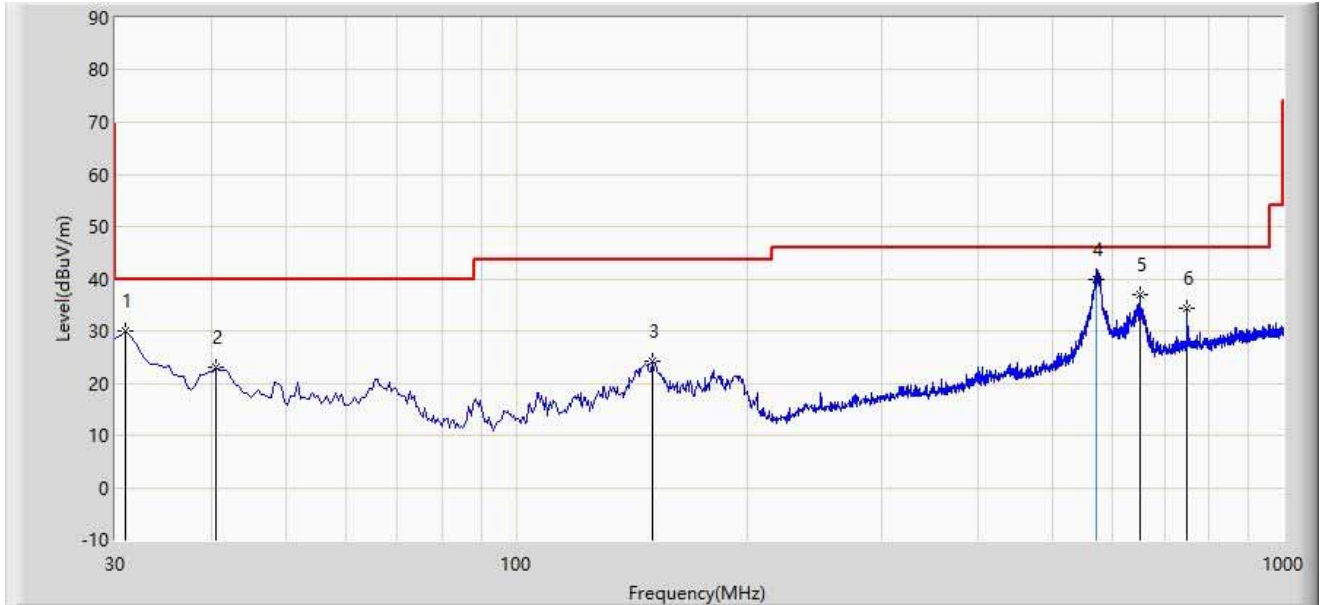

No	Flag	Mark	Frequency (MHz)	Measure Level (dBuV/m)	Reading Level (dBuV)	Margin (dB)	Limit (dBuV/m)	Factor (dB)	Type
1			30.970	29.907	13.333	-10.093	40.000	16.574	PK
2			40.670	23.166	5.539	-16.834	40.000	17.627	PK
3			150.280	24.115	5.987	-19.385	43.500	18.128	PK
4		*	571.745	39.727	15.300	-6.273	46.000	24.426	QP
5			649.830	37.005	10.980	-8.995	46.000	26.025	PK
6			750.225	34.492	6.655	-11.508	46.000	27.837	PK

Note: Measure Level (dB μ V/m) = Reading Level (dB μ V) + Factor (dB)

Factor (dB) = Cable Loss (dB) + Antenna Factor (dB/m)

6.8. Radiated Restricted Band Edge Measurement

6.8.1. Test Limit

For 15.205 Requirement:

Radiated emissions which fall in the restricted bands, as defined in Section 15.205(a) of FCC part 15, must also comply with the radiated emission limits specified in Section 15.209(a).

Frequency (MHz)	Frequency (MHz)	Frequency (MHz)	Frequency (GHz)
0.090 - 0.110	16.42-16.423	399.9 - 410	4.5-5.15
¹ 0.495 - 0.505	16.69475-16.69525	608 - 614	5.35-5.46
2.1735-2.1905	16.80425-16.80475	960 - 1240	7.25-7.75
4.125-4.128	25.5 -25.67	1300 - 1427	8.025 - 8.5
4.17725-4.17775	37.5-38.25	1435-1626.5	9.0-9.2
4.20725-4.20775	73-74.6	1645.5-1646.5	9.3-9.5
6.215-6.218	74.8-75.2	1660 - 1710	10.6-12.7
6.26775-6.26825	108-121.94	1718.8-1722.2	13.25-13.4
6.31175-6.31225	123 - 138	2200 - 2300	14.47-14.5
8.291-8.294	149.9-150.05	2310–2390	15.35-16.2
8.362-8.366	156.52475-156.52525	2483.5 - 2500	17.7-21.4
8.37625-8.38675	156.7-156.9	2690 - 2900	22.01-23.12
8.41425-8.41475	162.0125-167.17	3260 - 3267	23.6-24.0
12.29-12.293	167.72-173.2	3332 - 3339	31.2-31.8
12.51975-12.52025	240 - 285	3345.8 - 3358	36.43-36.5
12.57675-12.57725	322-335.4	3600 - 4400	(²)
13.36-13.41	--	--	--

For 15.407(b) Requirement:

For transmitters operating in the 5.15-5.25 GHz band: All emissions outside of the 5.15-5.35 GHz band shall not exceed an e.i.r.p. of -27 dBm/MHz.

For transmitters operating in the 5.25-5.35 GHz band: All emissions outside of the 5.15-5.35 GHz band shall not exceed an e.i.r.p. of -27 dBm/MHz.

For transmitters operating in the 5.47-5.725 GHz band: All emissions outside of the 5.47-5.725 GHz band shall not exceed an e.i.r.p. of -27 dBm/MHz.

For transmitters operating in the 5.725-5.85 GHz band: All emissions within the frequency range

from the band edge to 10 MHz above or below the band edge shall not exceed an e.i.r.p. of -17 dBm/MHz; for frequencies 10 MHz or greater above or below the band edge, emissions shall not exceed an e.i.r.p. of -27 dBm/MHz.

Refer to KDB 789033 D02v02r01 G)2)c), as specified in § 15.407(b), emissions above 1000 MHz that are outside of the restricted bands are subject to a maximum emission limit of -27 dBm/MHz (or -17 dBm/MHz as specified in § 15.407(b)(4)). However, an out-of-band emission that complies with both the peak and average limits of § 15.209 is not required to satisfy the -27 dBm/MHz or -17 dBm/MHz maximum emission limit.

All out of band emissions appearing in a restricted band as specified in Section 15.205 of the Title 47CFR must not exceed the limits shown in Table per Section 15.209.

FCC Part 15 Subpart C Paragraph 15.209		
Frequency (MHz)	Field Strength (µV/m)	Measured Distance (m)
0.009 - 0.490	2400/F (kHz)	300
0.490 - 1.705	24000/F (kHz)	30
1.705 - 30	30	30
30 - 88	100	3
88 - 216	150	3
216 - 960	200	3
Above 960	500	3

6.8.2. Test Procedure Used

KDB 789033 D02v02r01- Section G

6.8.3. Test Setting

Peak Measurements above 1GHz

1. Analyzer center frequency was set to the frequency of the radiated spurious emission of interest
2. RBW = 1MHz
3. VBW = 3MHz
4. Detector = Peak
5. Sweep time = Auto couple
6. Trace mode = Max hold
7. Trace was allowed to stabilize

Average Measurements above 1GHz (Method VB)

1. Analyzer center frequency was set to the frequency of the radiated spurious emission of interest
2. RBW = 1MHz
3. VBW; if the EUT is configured to transmit with duty cycle $\geq 98\%$, set VBW = 10Hz
4. If the EUT duty cycle is $< 98\%$, set VBW $\geq 1/T$. T is the minimum transmission duration
5. Detector = Peak
6. Sweep time = Auto
7. Trace mode = Max hold
8. Trace was allowed to stabilize

6.8.4. Test Setup

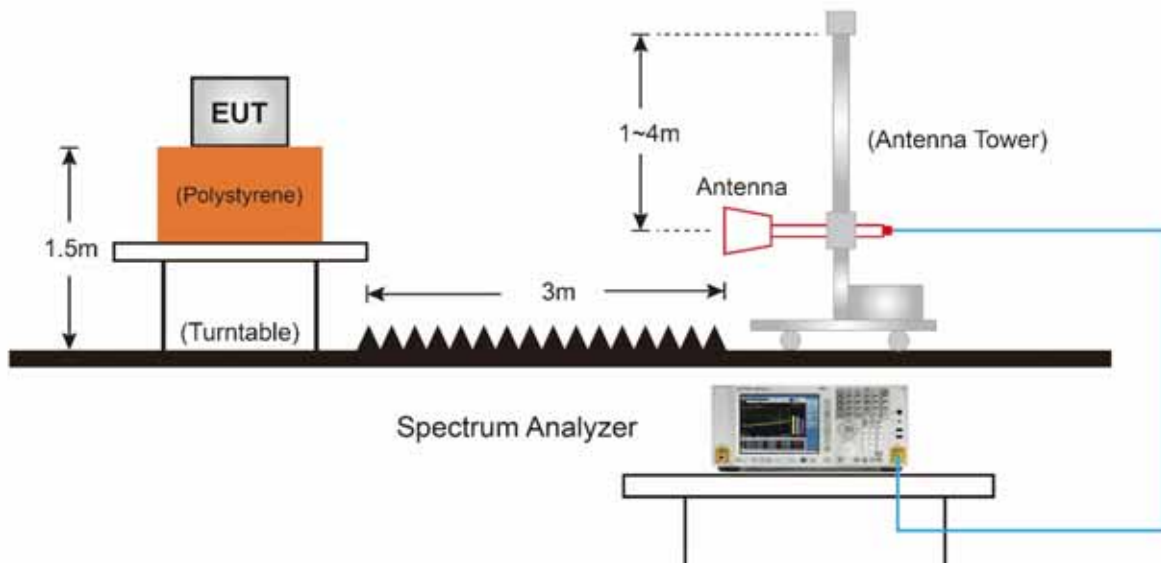

6.8.5. Test Result

CDD Mode:

Site: SIP-AC3	Time: 2021/01/31 - 14:17
Limit: FCC_Part15_209 RE(3m)	Engineer: White Wang
Probe: SIP-AC3_HF907_102861_1-18GHz	Polarity: Horizontal
EUT: Dual Band ONT	Power: AC 120V/60Hz
Test Mode: Transmit by 802.11a at channel 5320MHz	

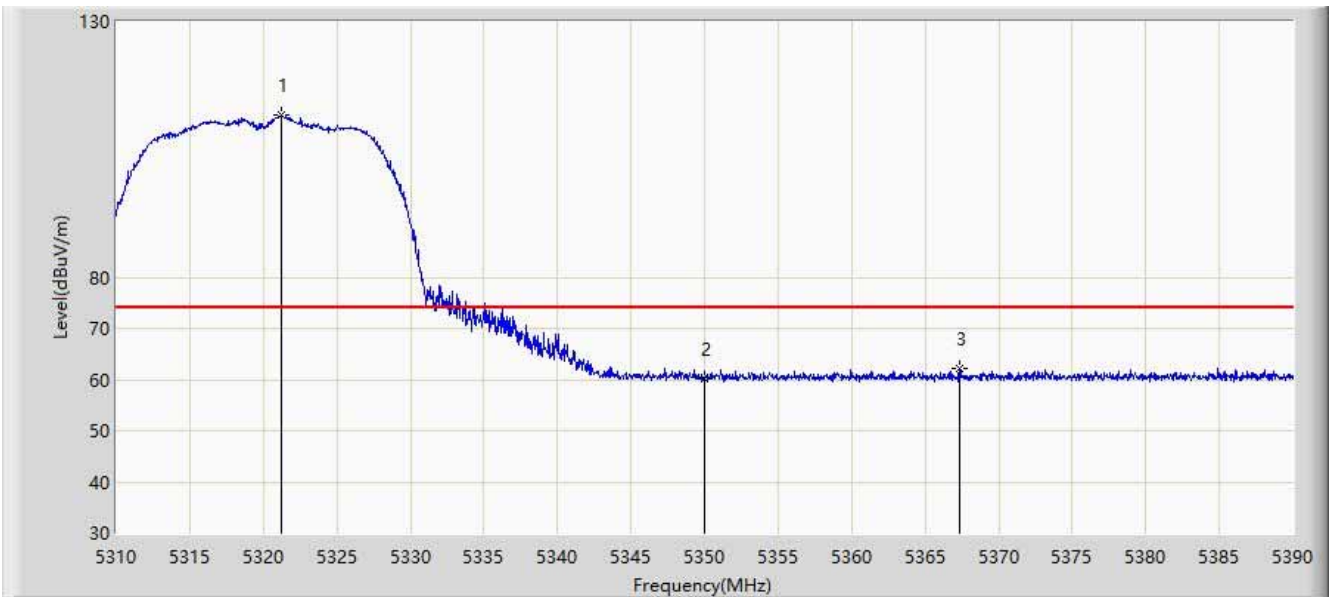

No	Flag	Mark	Frequency (MHz)	Measure Level (dB μ V/m)	Reading Level (dB μ V)	Margin (dB)	Limit (dB μ V/m)	Factor (dB)	Type
1		*	5321.200	111.613	120.810	N/A	N/A	-9.197	PK
2			5350.000	60.248	69.457	-13.752	74.000	-9.208	PK
3			5367.320	62.171	71.377	-11.829	74.000	-9.206	PK

Note: Measure Level (dB μ V/m) = Reading Level (dB μ V) + Factor (dB)

Factor (dB) = Cable Loss (dB) + Antenna Factor (dB/m) - Pre_Amplifier Gain (dB)

Site: SIP-AC3	Time: 2021/01/31 - 14:28
Limit: FCC_Part15_209 RE(3m)	Engineer: White Wang
Probe: SIP-AC3_HF907_102861_1-18GHz	Polarity: Horizontal
EUT: Dual Band ONT	Power: AC 120V/60Hz
Test Mode: Transmit by 802.11a at channel 5320MHz	

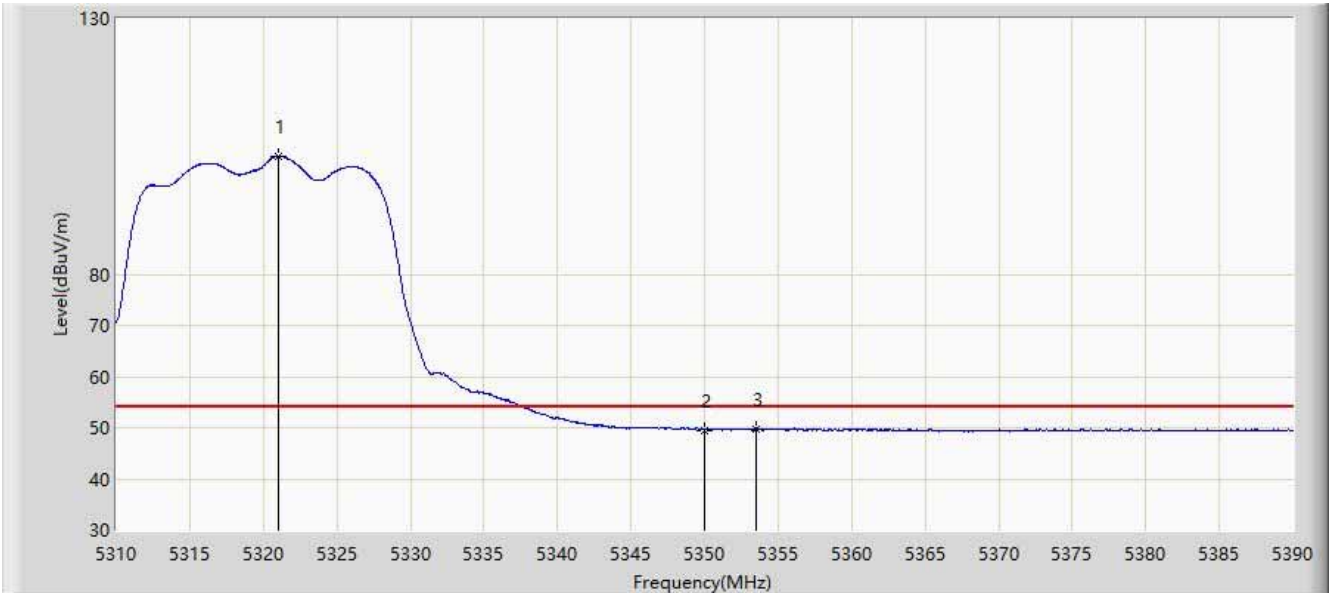

No	Flag	Mark	Frequency (MHz)	Measure Level (dBuV/m)	Reading Level (dBuV)	Margin (dB)	Limit (dBuV/m)	Factor (dB)	Type
1		*	5321.040	103.045	112.243	N/A	N/A	-9.199	AV
2			5350.000	49.546	58.755	-4.454	54.000	-9.208	AV
3			5353.520	49.853	59.080	-4.147	54.000	-9.227	AV

Note: Measure Level (dBuV/m) = Reading Level (dBuV) + Factor (dB)

Factor (dB) = Cable Loss (dB) + Antenna Factor (dB/m) - Pre_Amplifier Gain (dB)

Site: SIP-AC3	Time: 2021/01/31 - 14:09
Limit: FCC_Part15_209 RE(3m)	Engineer: White Wang
Probe: SIP-AC3_HF907_102861_1-18GHz	Polarity: Vertical
EUT: Dual Band ONT	Power: AC 120V/60Hz
Test Mode: Transmit by 802.11a at channel 5320MHz	

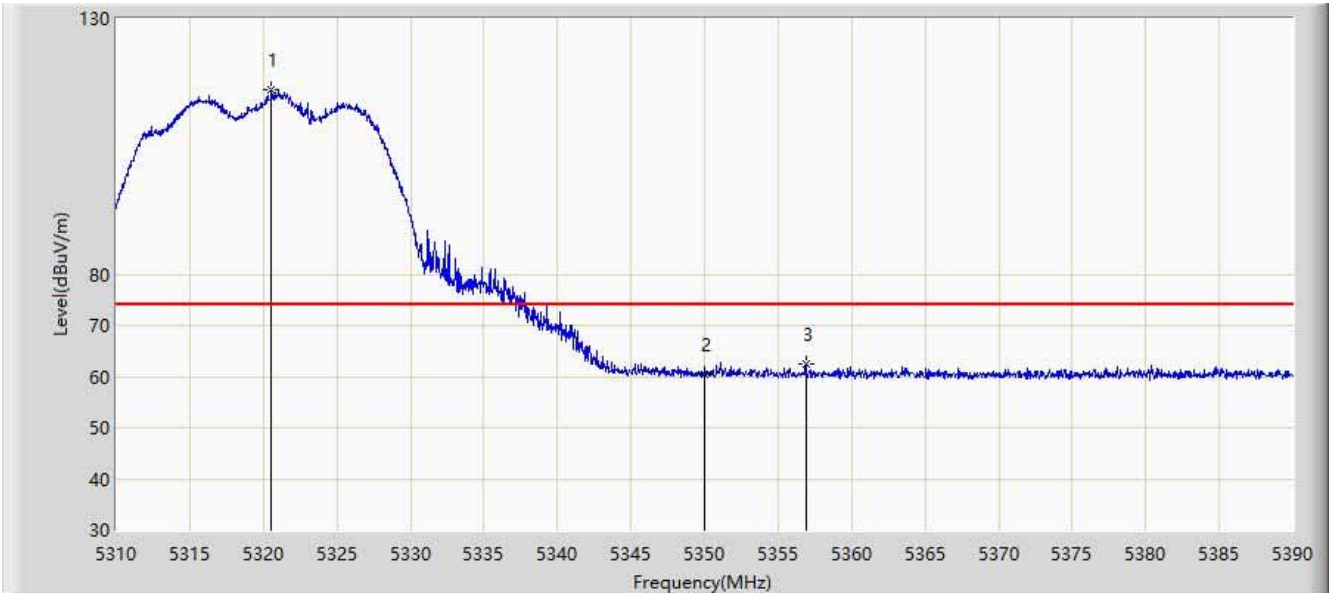

No	Flag	Mark	Frequency (MHz)	Measure Level (dBuV/m)	Reading Level (dBuV)	Margin (dB)	Limit (dBuV/m)	Factor (dB)	Type
1		*	5320.560	116.058	125.261	N/A	N/A	-9.204	PK
2			5350.000	60.462	69.671	-13.538	74.000	-9.208	PK
3			5356.880	62.572	71.794	-11.428	74.000	-9.221	PK

Note: Measure Level (dBuV/m) = Reading Level (dBuV) + Factor (dB)

Factor (dB) = Cable Loss (dB) + Antenna Factor (dB/m) - Pre_Amplifier Gain (dB)

Site: SIP-AC3	Time: 2021/01/31 - 14:15
Limit: FCC_Part15_209 RE(3m)	Engineer: White Wang
Probe: SIP-AC3_HF907_102861_1-18GHz	Polarity: Vertical
EUT: Dual Band ONT	Power: AC 120V/60Hz
Test Mode: Transmit by 802.11a at channel 5320MHz	

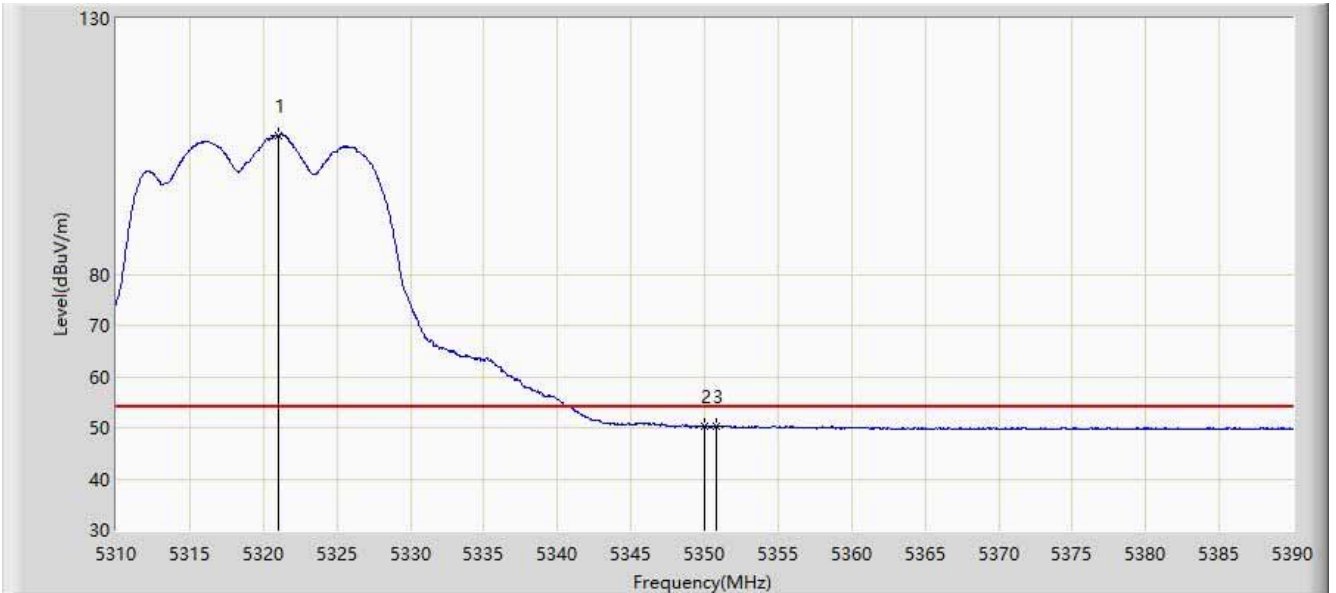

No	Flag	Mark	Frequency (MHz)	Measure Level (dB μ V/m)	Reading Level (dB μ V)	Margin (dB)	Limit (dB μ V/m)	Factor (dB)	Type
1		*	5321.040	107.184	116.382	N/A	N/A	-9.199	AV
2			5350.000	50.276	59.485	-3.724	54.000	-9.208	AV
3			5350.760	50.386	59.603	-3.614	54.000	-9.217	AV

Note: Measure Level (dB μ V/m) = Reading Level (dB μ V) + Factor (dB)

Factor (dB) = Cable Loss (dB) + Antenna Factor (dB/m) - Pre_Amplifier Gain (dB)

Site: SIP-AC3	Time: 2021/01/31 - 14:31
Limit: FCC_Part15_209 RE(3m)	Engineer: White Wang
Probe: SIP-AC3_HF907_102861_1-18GHz	Polarity: Horizontal
EUT: Dual Band ONT	Power: AC 120V/60Hz
Test Mode: Transmit by 802.11a at channel 5500MHz	

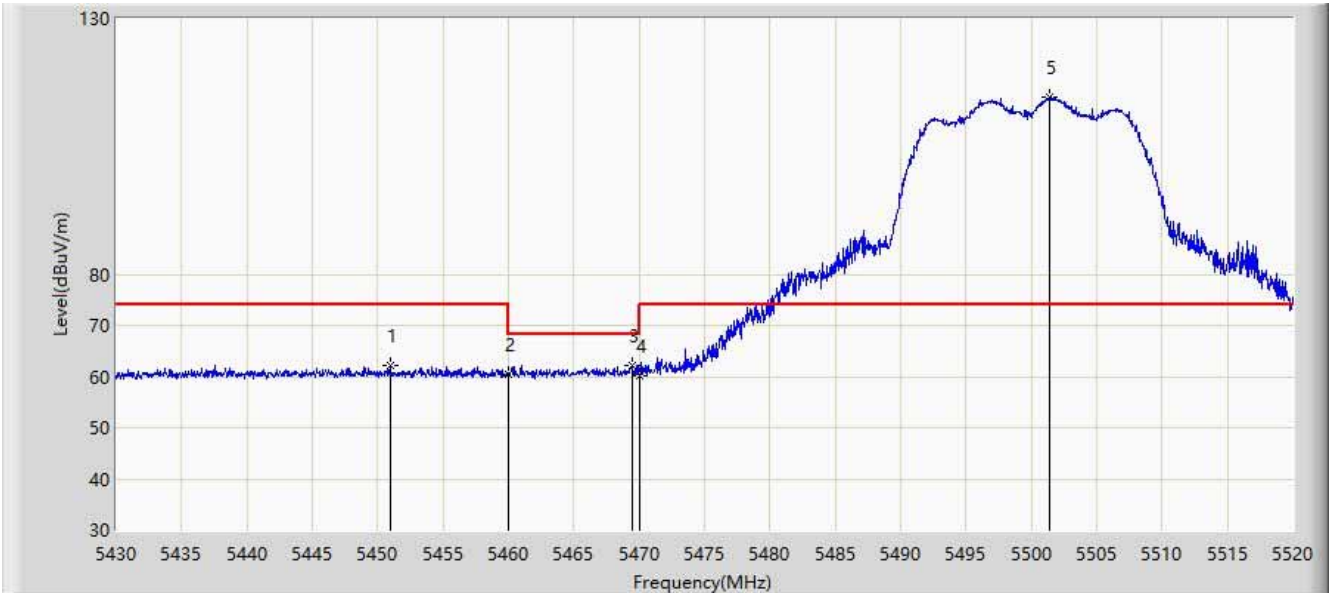

No	Flag	Mark	Frequency (MHz)	Measure Level (dBμV/m)	Reading Level (dBμV)	Margin (dB)	Limit (dBμV/m)	Factor (dB)	Type
1			5450.925	62.309	71.209	-11.691	74.000	-8.901	PK
2			5460.000	60.525	69.503	-13.475	74.000	-8.979	PK
3			5469.420	62.283	71.371	-5.917	68.200	-9.087	PK
4			5470.000	60.163	69.257	-8.037	68.200	-9.094	PK
5		*	5501.370	114.664	123.480	N/A	N/A	-8.817	PK

Note: Measure Level (dBμV/m) = Reading Level (dBμV) + Factor (dB)

Factor (dB) = Cable Loss (dB) + Antenna Factor (dB/m) - Pre_Amplifier Gain (dB)

Site: SIP-AC3	Time: 2021/01/31 - 14:37
Limit: FCC_Part15_209 RE(3m)	Engineer: White Wang
Probe: SIP-AC3_HF907_102861_1-18GHz	Polarity: Horizontal
EUT: Dual Band ONT	Power: AC 120V/60Hz
Test Mode: Transmit by 802.11a at channel 5500MHz	

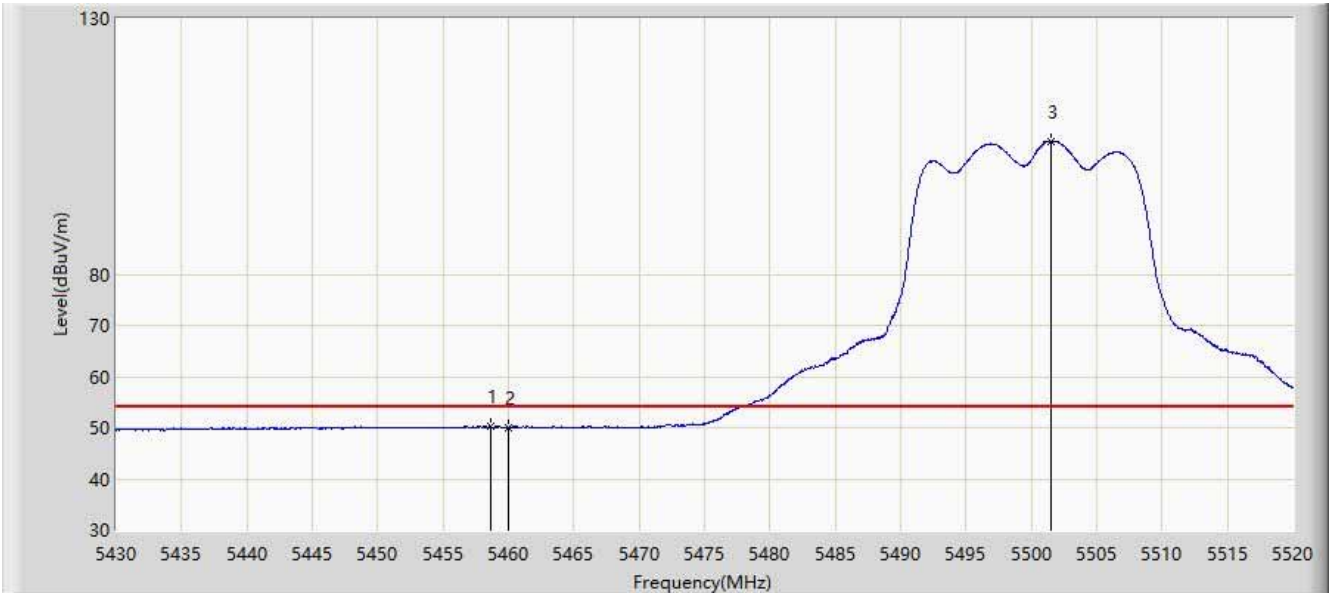

No	Flag	Mark	Frequency (MHz)	Measure Level (dBμV/m)	Reading Level (dBμV)	Margin (dB)	Limit (dBμV/m)	Factor (dB)	Type
1			5458.620	50.354	59.316	-3.646	54.000	-8.961	AV
2			5460.000	50.116	59.094	-3.884	54.000	-8.979	AV
3		*	5501.460	106.066	114.882	N/A	N/A	-8.816	AV

Note: Measure Level (dBμV/m) = Reading Level (dBμV) + Factor (dB)

Factor (dB) = Cable Loss (dB) + Antenna Factor (dB/m) - Pre_Amplifier Gain (dB)

Site: SIP-AC3	Time: 2021/01/31 - 14:38
Limit: FCC_Part15_209 RE(3m)	Engineer: White Wang
Probe: SIP-AC3_HF907_102861_1-18GHz	Polarity: Vertical
EUT: Dual Band ONT	Power: AC 120V/60Hz
Test Mode: Transmit by 802.11a at channel 5500MHz	

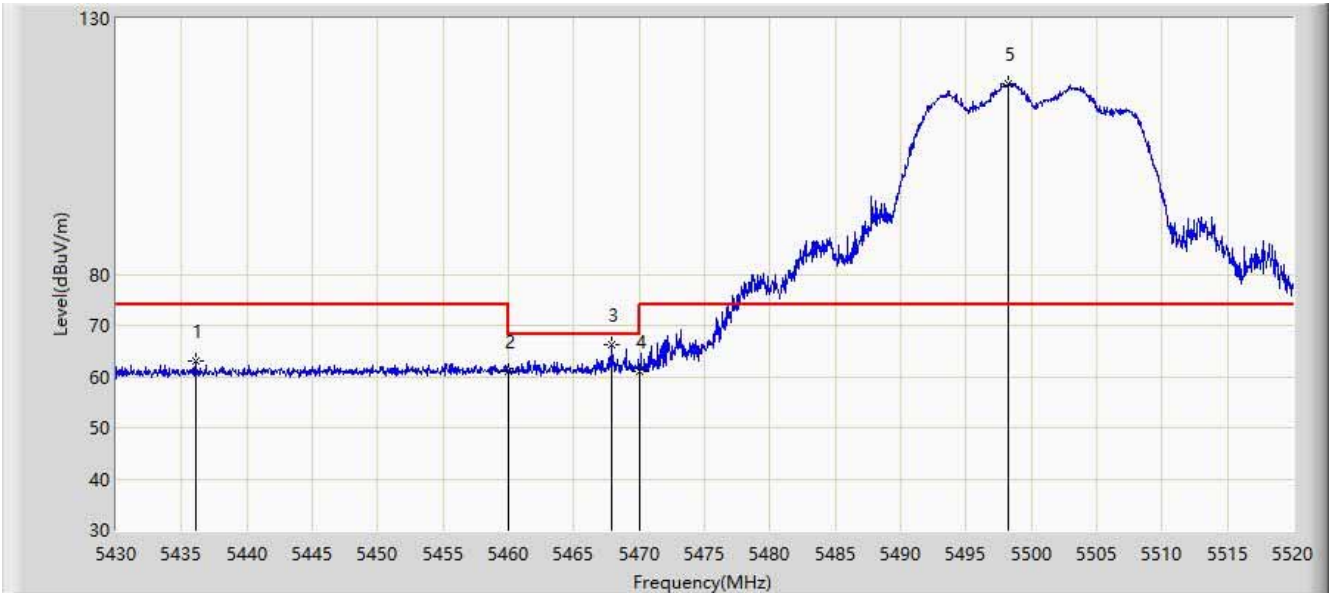

No	Flag	Mark	Frequency (MHz)	Measure Level (dBμV/m)	Reading Level (dBμV)	Margin (dB)	Limit (dBμV/m)	Factor (dB)	Type
1			5436.075	63.173	72.049	-10.827	74.000	-8.877	PK
2			5460.000	61.088	70.066	-12.912	74.000	-8.979	PK
3			5467.890	66.318	75.388	-1.882	68.200	-9.070	PK
4			5470.000	61.150	70.244	-7.050	68.200	-9.094	PK
5		*	5498.220	117.151	125.992	N/A	N/A	-8.841	PK

Note: Measure Level (dBμV/m) = Reading Level (dBμV) + Factor (dB)

Factor (dB) = Cable Loss (dB) + Antenna Factor (dB/m) - Pre_Amplifier Gain (dB)

Site: SIP-AC3	Time: 2021/01/31 - 14:44
Limit: FCC_Part15_209 RE(3m)	Engineer: White Wang
Probe: SIP-AC3_HF907_102861_1-18GHz	Polarity: Vertical
EUT: Dual Band ONT	Power: AC 120V/60Hz
Test Mode: Transmit by 802.11a at channel 5500MHz	

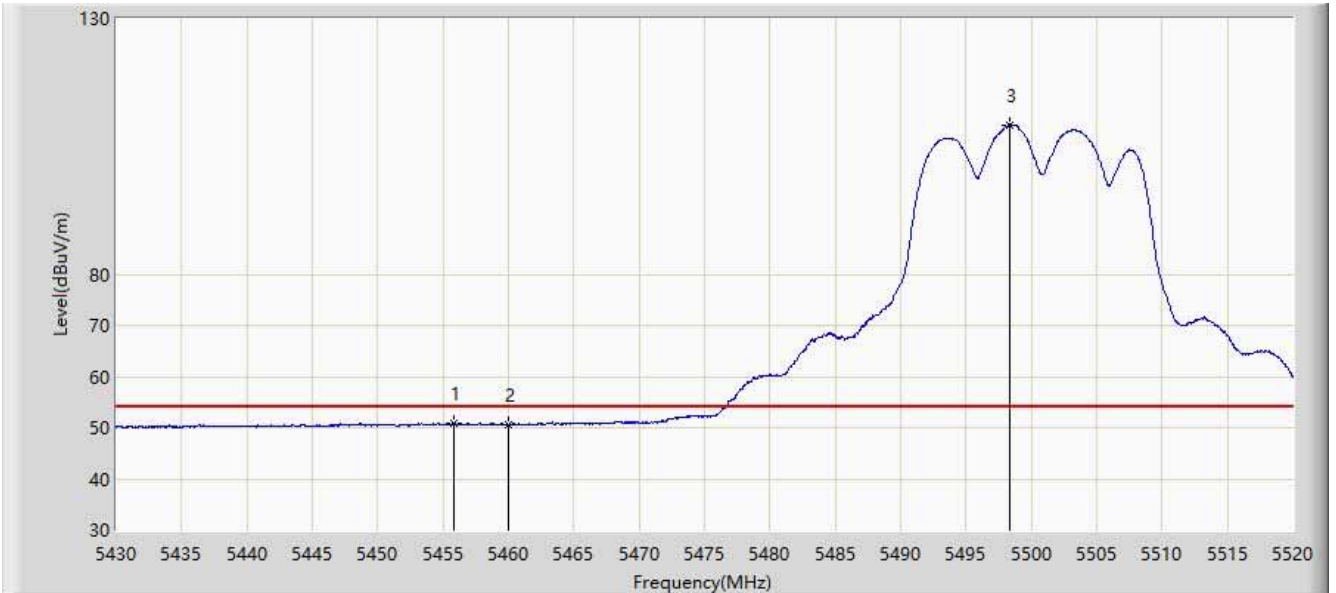

No	Flag	Mark	Frequency (MHz)	Measure Level (dBuV/m)	Reading Level (dBuV)	Margin (dB)	Limit (dBuV/m)	Factor (dB)	Type
1			5455.785	50.855	59.784	-3.145	54.000	-8.928	AV
2			5460.000	50.652	59.630	-3.348	54.000	-8.979	AV
3	X	*	5498.400	109.249	118.089	N/A	N/A	-8.840	AV

Note: Measure Level (dBuV/m) = Reading Level (dBuV) + Factor (dB)

Factor (dB) = Cable Loss (dB) + Antenna Factor (dB/m) - Pre_Amplifier Gain (dB)

Site: SIP-AC3	Time: 2021/01/31 - 14:46
Limit: FCC_Part15_209 RE(3m)	Engineer: White Wang
Probe: SIP-AC3_HF907_102861_1-18GHz	Polarity: Horizontal
EUT: Dual Band ONT	Power: AC 120V/60Hz
Test Mode: Transmit by 802.11a at channel 5700MHz	

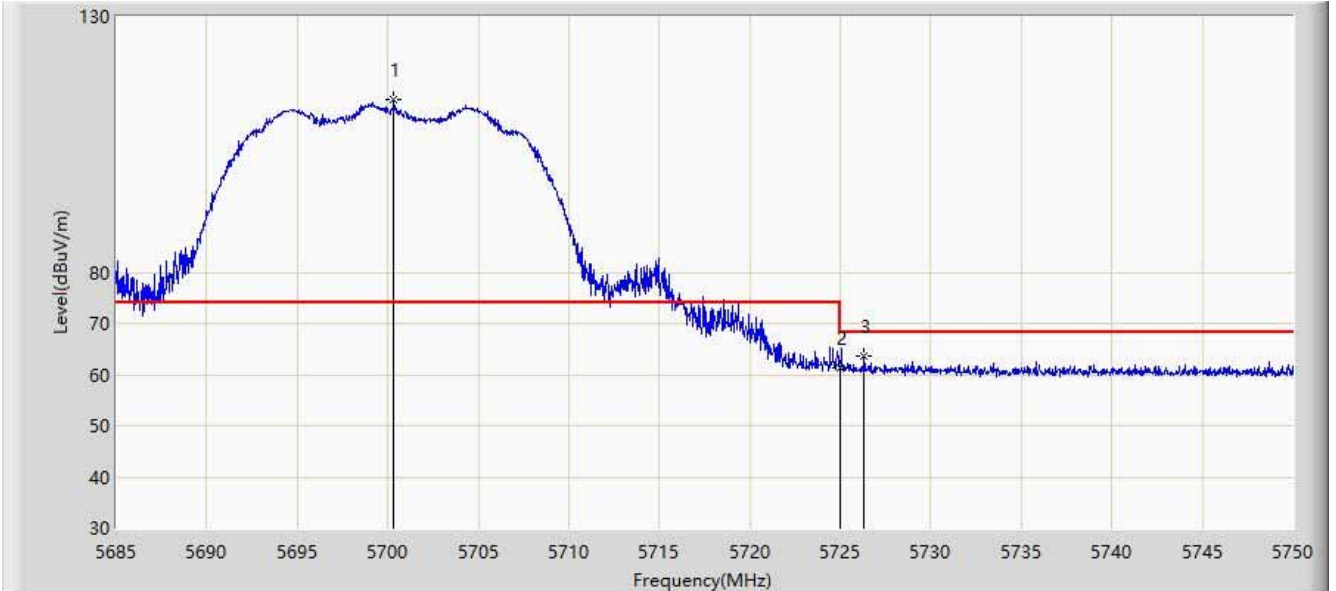

No	Flag	Mark	Frequency (MHz)	Measure Level (dBμV/m)	Reading Level (dBμV)	Margin (dB)	Limit (dBμV/m)	Factor (dB)	Type
1		*	5700.340	113.624	122.870	N/A	N/A	-9.246	PK
2			5725.000	61.352	70.403	-6.848	68.200	-9.051	PK
3			5726.308	63.592	72.636	-4.608	68.200	-9.044	PK

Note: Measure Level (dBμV/m) = Reading Level (dBμV) + Factor (dB)

Factor (dB) = Cable Loss (dB) + Antenna Factor (dB/m) - Pre_Amplifier Gain (dB)

Site: SIP-AC3	Time: 2021/01/31 - 14:51
Limit: FCC_Part15_209 RE(3m)	Engineer: White Wang
Probe: SIP-AC3_HF907_102861_1-18GHz	Polarity: Vertical
EUT: Dual Band ONT	Power: AC 120V/60Hz
Test Mode: Transmit by 802.11a at channel 5700MHz	

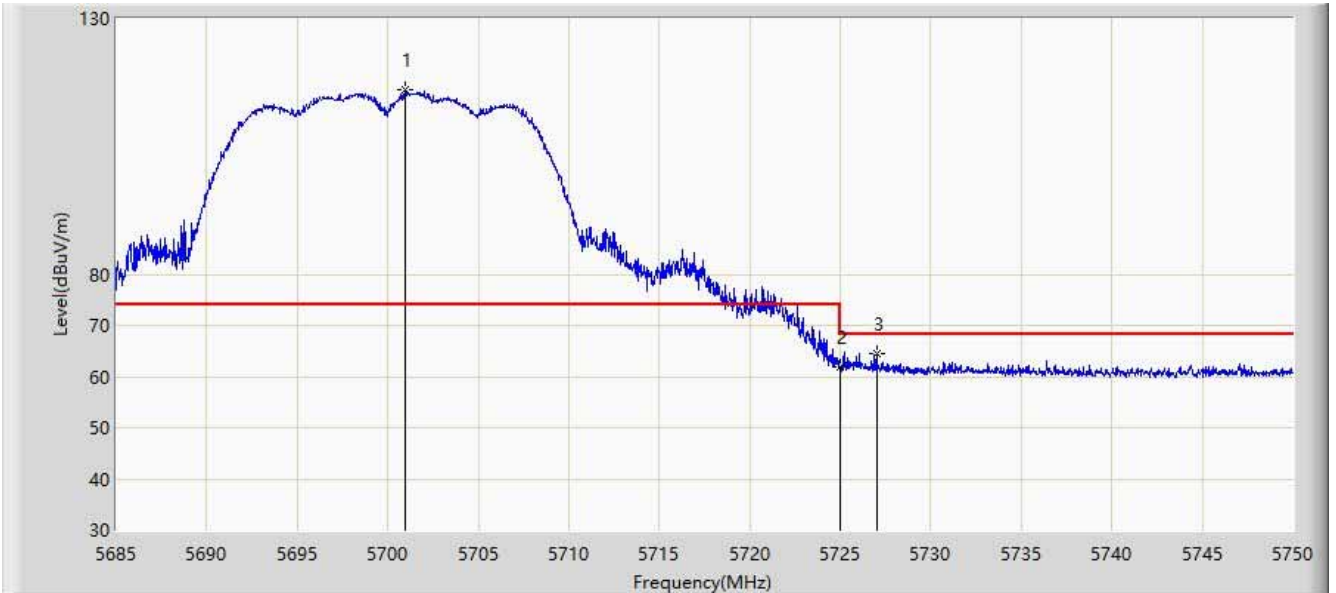

No	Flag	Mark	Frequency (MHz)	Measure Level (dB μ V/m)	Reading Level (dB μ V)	Margin (dB)	Limit (dB μ V/m)	Factor (dB)	Type
1		*	5700.925	116.030	125.276	N/A	N/A	-9.245	PK
2			5725.000	61.906	70.957	-6.294	68.200	-9.051	PK
3			5727.022	64.411	73.466	-3.789	68.200	-9.055	PK

Note: Measure Level (dB μ V/m) = Reading Level (dB μ V) + Factor (dB)

Factor (dB) = Cable Loss (dB) + Antenna Factor (dB/m) - Pre_Amplifier Gain (dB)

Site: SIP-AC3	Time: 2021/01/31 - 14:55
Limit: FCC_Part15_209 RE(3m)	Engineer: White Wang
Probe: SIP-AC3_HF907_102861_1-18GHz	Polarity: Horizontal
EUT: Dual Band ONT	Power: AC 120V/60Hz
Test Mode: Transmit by 802.11n-HT20 at channel 5320MHz	

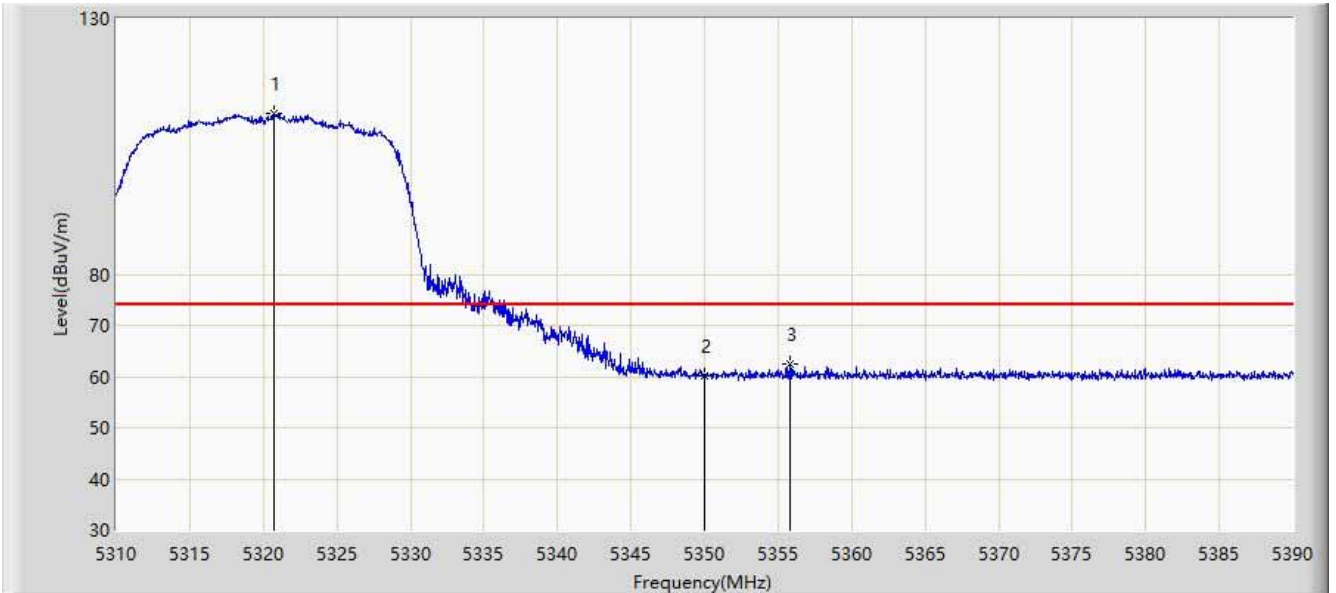

No	Flag	Mark	Frequency (MHz)	Measure Level (dB μ V/m)	Reading Level (dB μ V)	Margin (dB)	Limit (dB μ V/m)	Factor (dB)	Type
1		*	5320.720	111.375	120.577	N/A	N/A	-9.202	PK
2			5350.000	60.276	69.485	-13.724	74.000	-9.208	PK
3			5355.840	62.423	71.646	-11.577	74.000	-9.223	PK

Note: Measure Level (dB μ V/m) = Reading Level (dB μ V) + Factor (dB)

Factor (dB) = Cable Loss (dB) + Antenna Factor (dB/m) - Pre_Amplifier Gain (dB)

Site: SIP-AC3	Time: 2021/01/31 - 15:02
Limit: FCC_Part15_209 RE(3m)	Engineer: White Wang
Probe: SIP-AC3_HF907_102861_1-18GHz	Polarity: Horizontal
EUT: Dual Band ONT	Power: AC 120V/60Hz
Test Mode: Transmit by 802.11n-HT20 at channel 5320MHz	

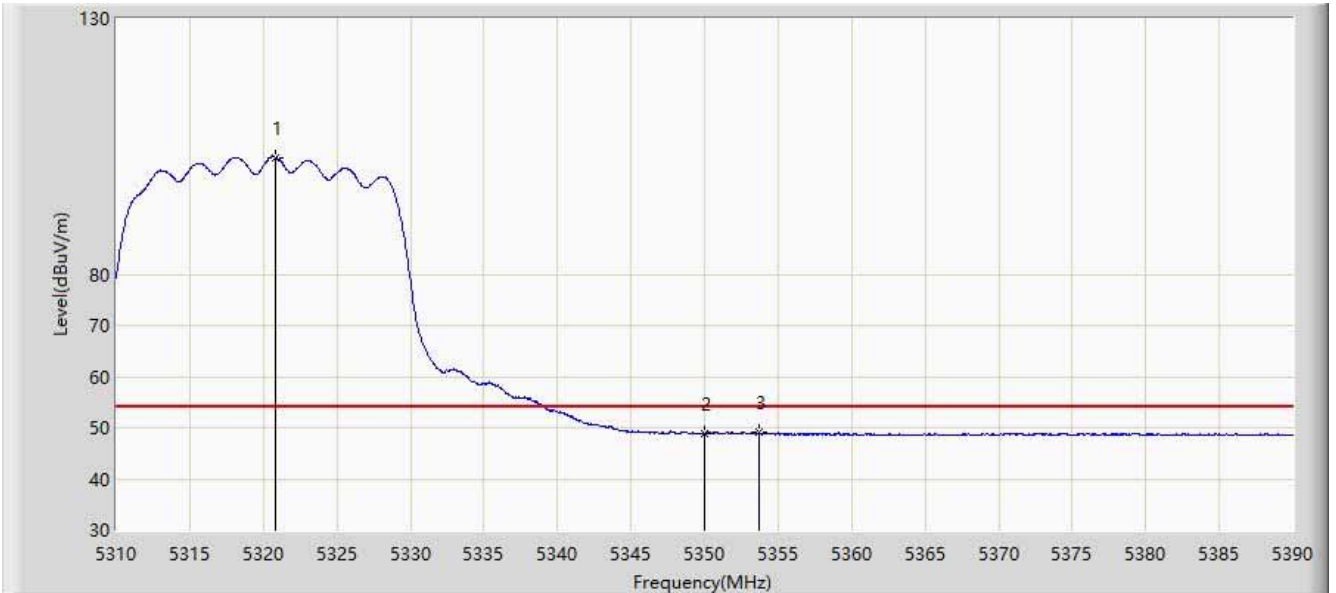

No	Flag	Mark	Frequency (MHz)	Measure Level (dBuV/m)	Reading Level (dBuV)	Margin (dB)	Limit (dBuV/m)	Factor (dB)	Type
1		*	5320.800	102.880	112.081	N/A	N/A	-9.201	AV
2			5350.000	48.746	57.955	-5.254	54.000	-9.208	AV
3			5353.680	49.050	58.277	-4.950	54.000	-9.227	AV

Note: Measure Level (dBuV/m) = Reading Level (dBuV) + Factor (dB)

Factor (dB) = Cable Loss (dB) + Antenna Factor (dB/m) - Pre_Amplifier Gain (dB)

Site: SIP-AC3	Time: 2021/01/31 - 15:06
Limit: FCC_Part15_209 RE(3m)	Engineer: White Wang
Probe: SIP-AC3_HF907_102861_1-18GHz	Polarity: Vertical
EUT: Dual Band ONT	Power: AC 120V/60Hz
Test Mode: Transmit by 802.11n-HT20 at channel 5320MHz	

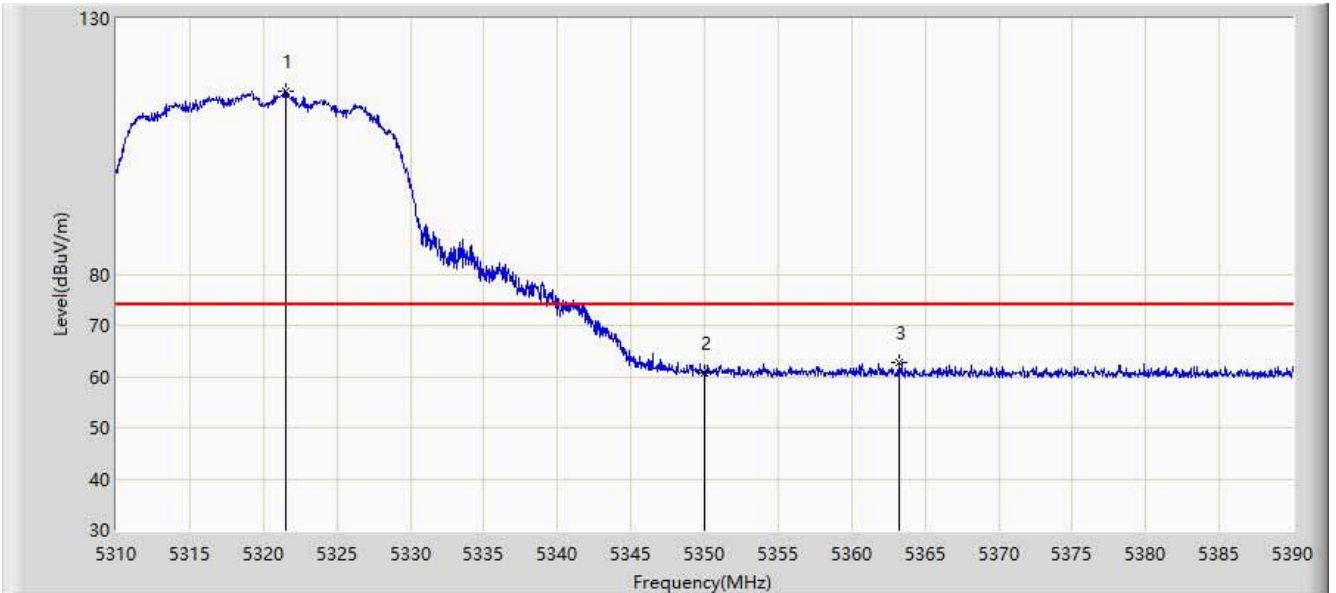

No	Flag	Mark	Frequency (MHz)	Measure Level (dB μ V/m)	Reading Level (dB μ V)	Margin (dB)	Limit (dB μ V/m)	Factor (dB)	Type
1		*	5321.560	115.654	124.847	N/A	N/A	-9.193	PK
2			5350.000	60.694	69.903	-13.306	74.000	-9.208	PK
3			5363.200	62.772	71.985	-11.228	74.000	-9.213	PK

Note: Measure Level (dB μ V/m) = Reading Level (dB μ V) + Factor (dB)

Factor (dB) = Cable Loss (dB) + Antenna Factor (dB/m) - Pre_Amplifier Gain (dB)

Site: SIP-AC3	Time: 2021/01/31 - 15:11
Limit: FCC_Part15_209 RE(3m)	Engineer: White Wang
Probe: SIP-AC3_HF907_102861_1-18GHz	Polarity: Vertical
EUT: Dual Band ONT	Power: AC 120V/60Hz
Test Mode: Transmit by 802.11n-HT20 at channel 5320MHz	

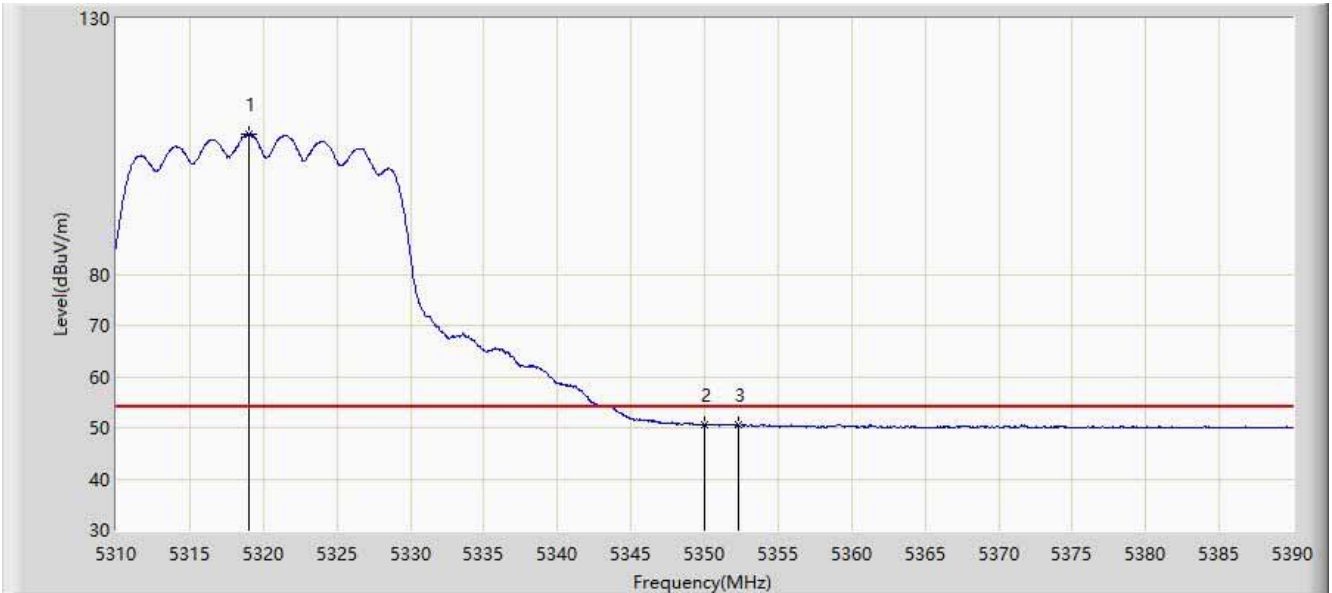

No	Flag	Mark	Frequency (MHz)	Measure Level (dBμV/m)	Reading Level (dBμV)	Margin (dB)	Limit (dBμV/m)	Factor (dB)	Type
1		*	5319.040	107.455	116.674	N/A	N/A	-9.219	AV
2			5350.000	50.446	59.655	-3.554	54.000	-9.208	AV
3			5352.280	50.644	59.873	-3.356	54.000	-9.229	AV

Note: Measure Level (dBμV/m) = Reading Level (dBμV) + Factor (dB)

Factor (dB) = Cable Loss (dB) + Antenna Factor (dB/m) - Pre_Amplifier Gain (dB)

Site: SIP-AC3	Time: 2021/01/31 - 15:13
Limit: FCC_Part15_209 RE(3m)	Engineer: White Wang
Probe: SIP-AC3_HF907_102861_1-18GHz	Polarity: Horizontal
EUT: Dual Band ONT	Power: AC 120V/60Hz
Test Mode: Transmit by 802.11n-HT20 at channel 5500MHz	

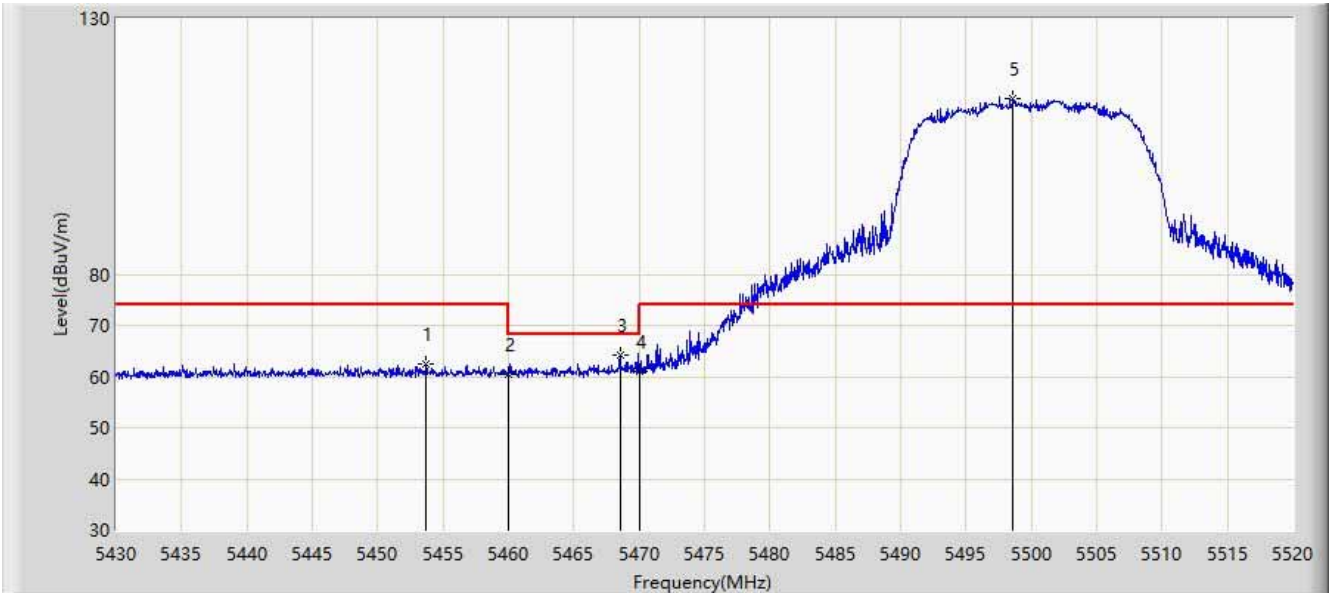

No	Flag	Mark	Frequency (MHz)	Measure Level (dBμV/m)	Reading Level (dBμV)	Margin (dB)	Limit (dBμV/m)	Factor (dB)	Type
1			5453.715	62.534	71.441	-11.466	74.000	-8.908	PK
2			5460.000	60.533	69.511	-13.467	74.000	-8.979	PK
3			5468.520	64.125	73.202	-4.075	68.200	-9.078	PK
4			5470.000	61.142	70.236	-7.058	68.200	-9.094	PK
5		*	5498.580	114.404	123.242	N/A	N/A	-8.838	PK

Note: Measure Level (dBμV/m) = Reading Level (dBμV) + Factor (dB)

Factor (dB) = Cable Loss (dB) + Antenna Factor (dB/m) - Pre_Amplifier Gain (dB)

Site: SIP-AC3	Time: 2021/01/31 - 15:18
Limit: FCC_Part15_209 RE(3m)	Engineer: White Wang
Probe: SIP-AC3_HF907_102861_1-18GHz	Polarity: Horizontal
EUT: Dual Band ONT	Power: AC 120V/60Hz
Test Mode: Transmit by 802.11n-HT20 at channel 5500MHz	

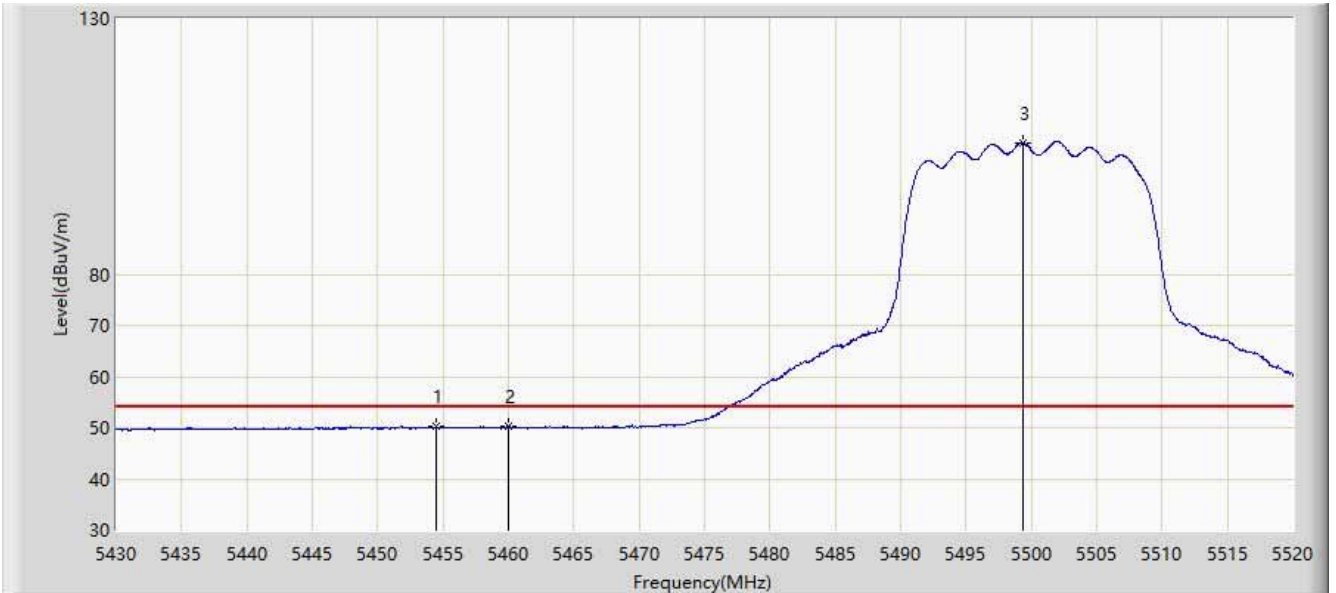

No	Flag	Mark	Frequency (MHz)	Measure Level (dB μ V/m)	Reading Level (dB μ V)	Margin (dB)	Limit (dB μ V/m)	Factor (dB)	Type
1			5454.435	50.259	59.172	-3.741	54.000	-8.913	AV
2			5460.000	50.158	59.136	-3.842	54.000	-8.979	AV
3		*	5499.390	105.704	114.536	N/A	N/A	-8.832	AV

Note: Measure Level (dB μ V/m) = Reading Level (dB μ V) + Factor (dB)

Factor (dB) = Cable Loss (dB) + Antenna Factor (dB/m) - Pre_Amplifier Gain (dB)

Site: SIP-AC3	Time: 2021/01/31 - 15:19
Limit: FCC_Part15_209 RE(3m)	Engineer: White Wang
Probe: SIP-AC3_HF907_102861_1-18GHz	Polarity: Vertical
EUT: Dual Band ONT	Power: AC 120V/60Hz
Test Mode: Transmit by 802.11n-HT20 at channel 5500MHz	

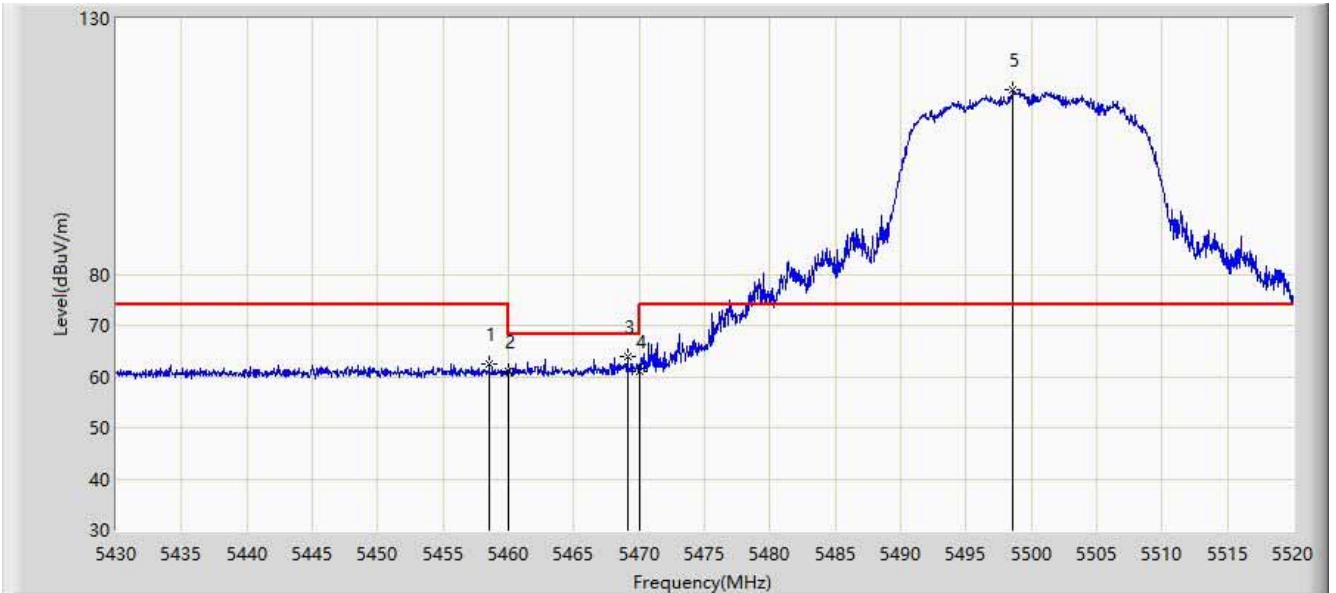

No	Flag	Mark	Frequency (MHz)	Measure Level (dBμV/m)	Reading Level (dBμV)	Margin (dB)	Limit (dBμV/m)	Factor (dB)	Type
1			5458.530	62.602	71.563	-11.398	74.000	-8.961	PK
2			5460.000	61.016	69.994	-12.984	74.000	-8.979	PK
3			5469.105	63.973	73.057	-4.227	68.200	-9.085	PK
4			5470.000	61.046	70.140	-7.154	68.200	-9.094	PK
5		*	5498.580	116.205	125.043	N/A	N/A	-8.838	PK

Note: Measure Level (dBμV/m) = Reading Level (dBμV) + Factor (dB)

Factor (dB) = Cable Loss (dB) + Antenna Factor (dB/m) - Pre_Amplifier Gain (dB)

Site: SIP-AC3	Time: 2021/01/31 - 15:23
Limit: FCC_Part15_209 RE(3m)	Engineer: White Wang
Probe: SIP-AC3_HF907_102861_1-18GHz	Polarity: Vertical
EUT: Dual Band ONT	Power: AC 120V/60Hz
Test Mode: Transmit by 802.11n-HT20 at channel 5500MHz	

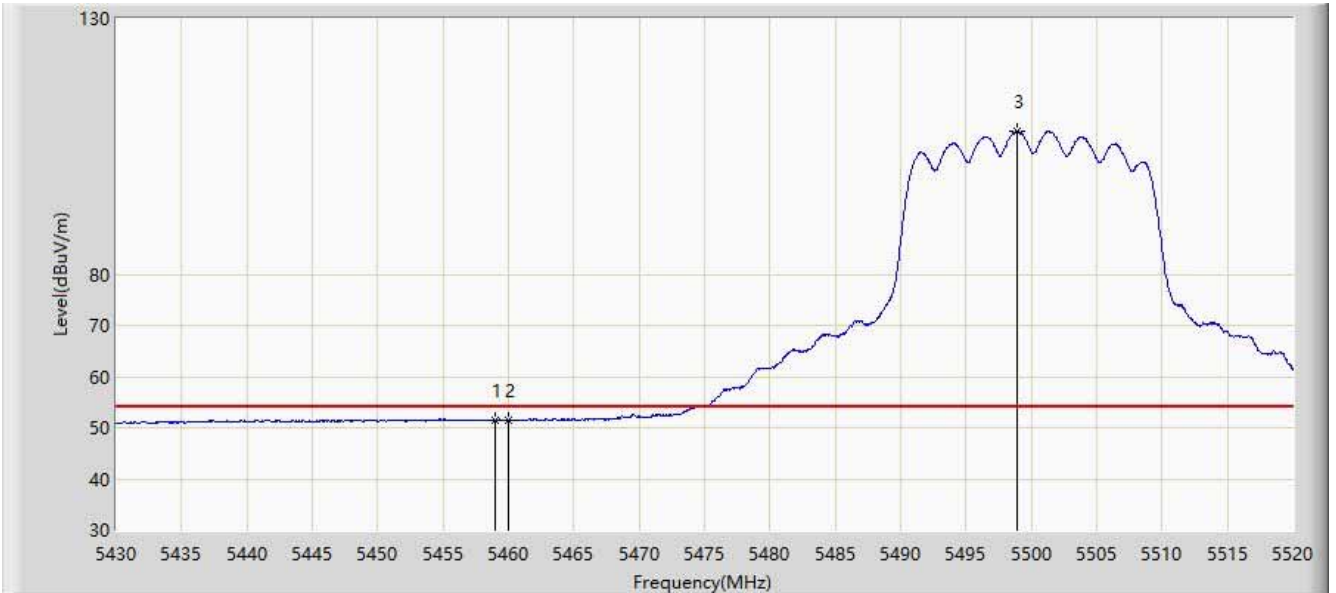

No	Flag	Mark	Frequency (MHz)	Measure Level (dB μ V/m)	Reading Level (dB μ V)	Margin (dB)	Limit (dB μ V/m)	Factor (dB)	Type
1			5458.980	51.566	60.532	-2.434	54.000	-8.966	AV
2			5460.000	51.511	60.489	-2.489	54.000	-8.979	AV
3		*	5498.940	107.951	116.786	N/A	N/A	-8.836	AV

Note: Measure Level (dB μ V/m) = Reading Level (dB μ V) + Factor (dB)

Factor (dB) = Cable Loss (dB) + Antenna Factor (dB/m) - Pre_Amplifier Gain (dB)

Site: SIP-AC3	Time: 2021/01/31 - 15:28
Limit: FCC_Part15_209 RE(3m)	Engineer: White Wang
Probe: SIP-AC3_HF907_102861_1-18GHz	Polarity: Horizontal
EUT: Dual Band ONT	Power: AC 120V/60Hz
Test Mode: Transmit by 802.11n-HT20 at channel 5700MHz	

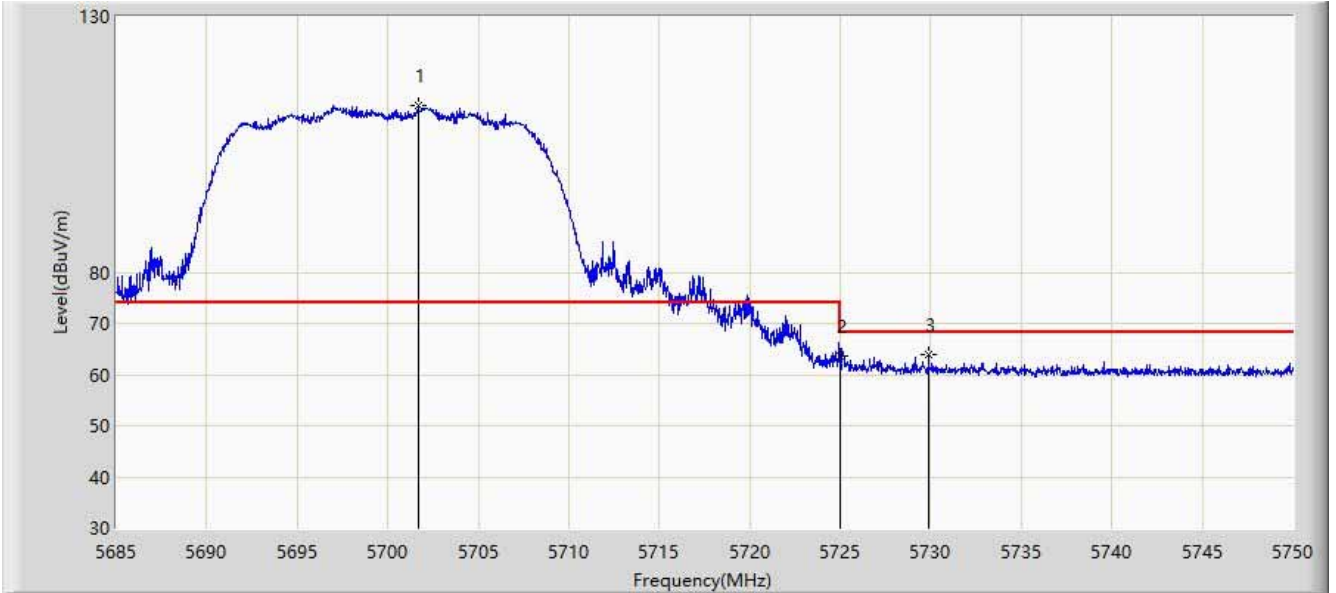

No	Flag	Mark	Frequency (MHz)	Measure Level (dBμV/m)	Reading Level (dBμV)	Margin (dB)	Limit (dBμV/m)	Factor (dB)	Type
1		*	5701.672	112.553	121.800	N/A	N/A	-9.247	PK
2			5725.000	63.714	72.765	-4.486	68.200	-9.051	PK
3			5729.882	64.010	73.108	-4.190	68.200	-9.098	PK

Note: Measure Level (dBμV/m) = Reading Level (dBμV) + Factor (dB)

Factor (dB) = Cable Loss (dB) + Antenna Factor (dB/m) - Pre_Amplifier Gain (dB)

Site: SIP-AC3	Time: 2021/01/31 - 15:30
Limit: FCC_Part15_209 RE(3m)	Engineer: White Wang
Probe: SIP-AC3_HF907_102861_1-18GHz	Polarity: Vertical
EUT: Dual Band ONT	Power: AC 120V/60Hz
Test Mode: Transmit by 802.11n-HT20 at channel 5700MHz	

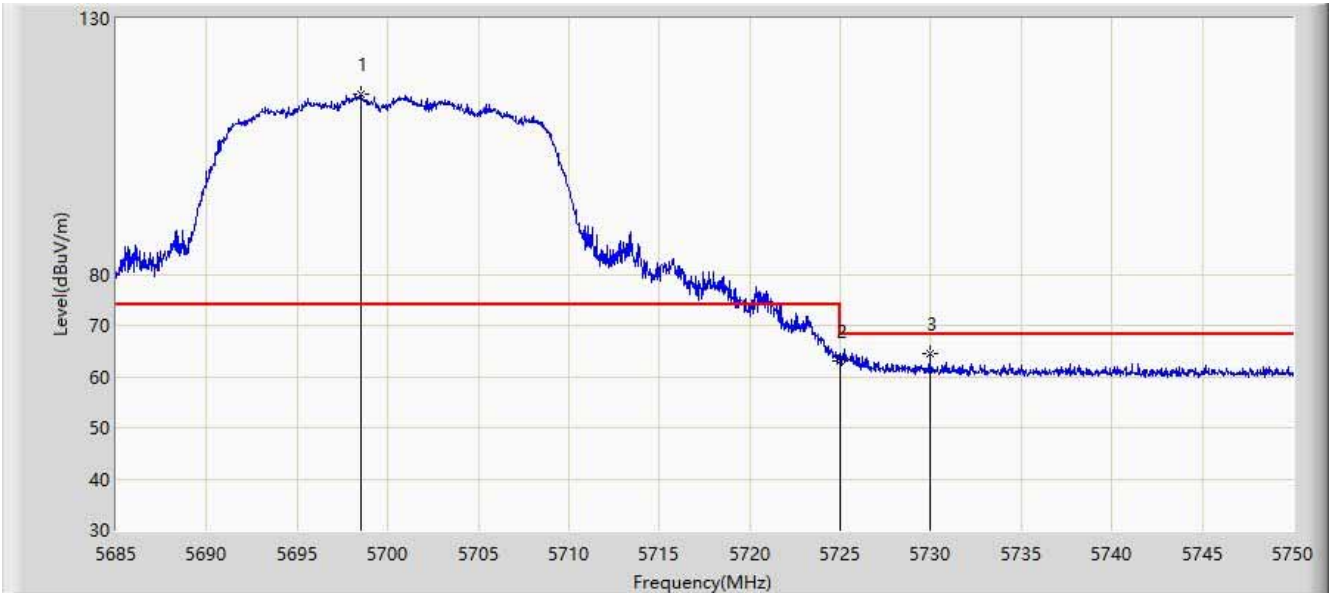

No	Flag	Mark	Frequency (MHz)	Measure Level (dB μ V/m)	Reading Level (dB μ V)	Margin (dB)	Limit (dB μ V/m)	Factor (dB)	Type
1		*	5698.520	115.173	124.418	N/A	N/A	-9.245	PK
2			5725.000	63.038	72.089	-5.162	68.200	-9.051	PK
3			5729.947	64.523	73.622	-3.677	68.200	-9.099	PK

Note: Measure Level (dB μ V/m) = Reading Level (dB μ V) + Factor (dB)

Factor (dB) = Cable Loss (dB) + Antenna Factor (dB/m) - Pre_Amplifier Gain (dB)

Site: SIP-AC3	Time: 2021/02/04 - 17:10
Limit: FCC_Part15_209 RE(3m)	Engineer: White Wang
Probe: SIP-AC3_HF907_102861_1-18GHz	Polarity: Horizontal
EUT: Dual Band ONT #2	Power: AC 120V/60Hz
Test Mode: Transmit by 802.11n-HT40 at channel 5310MHz	

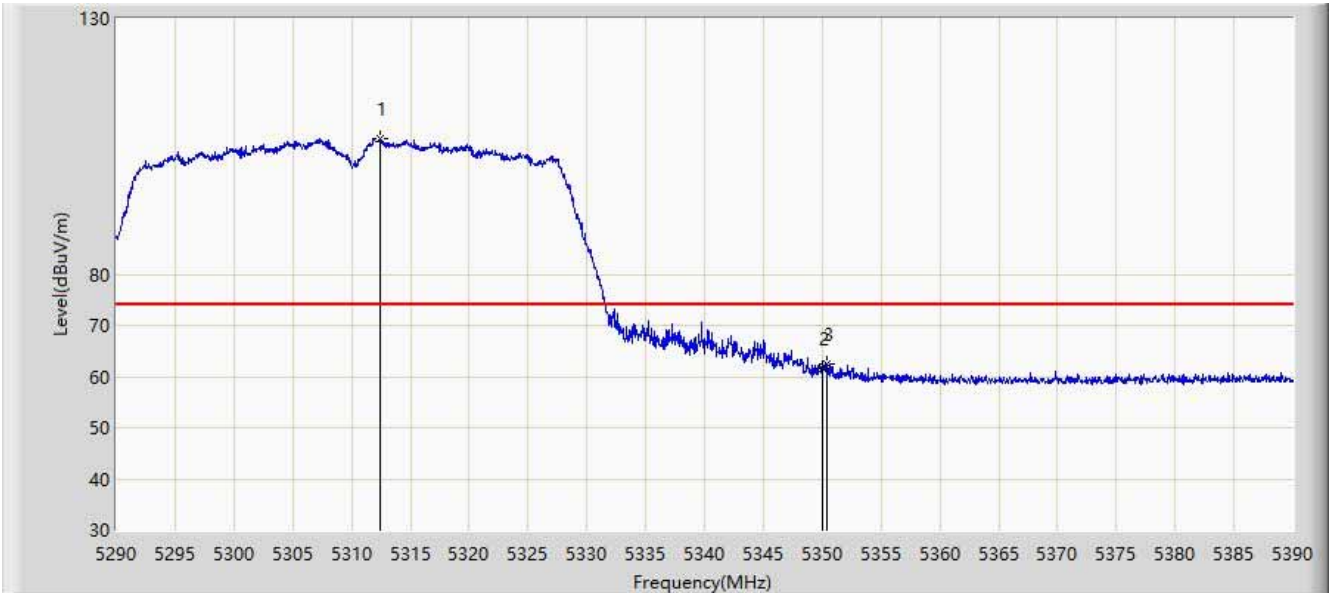

No	Flag	Mark	Frequency (MHz)	Measure Level (dB μ V/m)	Reading Level (dB μ V)	Margin (dB)	Limit (dB μ V/m)	Factor (dB)	Type
1		*	5312.450	106.637	115.946	N/A	N/A	-9.309	PK
2			5350.000	61.588	70.797	-12.412	74.000	-9.208	PK
3			5350.450	62.484	71.697	-11.516	74.000	-9.213	PK

Note: Measure Level (dB μ V/m) = Reading Level (dB μ V) + Factor (dB)

Factor (dB) = Cable Loss (dB) + Antenna Factor (dB/m) - Pre_Amplifier Gain (dB)

Site: SIP-AC3	Time: 2021/02/04 - 17:15
Limit: FCC_Part15_209 RE(3m)	Engineer: White Wang
Probe: SIP-AC3_HF907_102861_1-18GHz	Polarity: Horizontal
EUT: Dual Band ONT #2	Power: AC 120V/60Hz
Test Mode: Transmit by 802.11n-HT40 at channel 5310MHz	

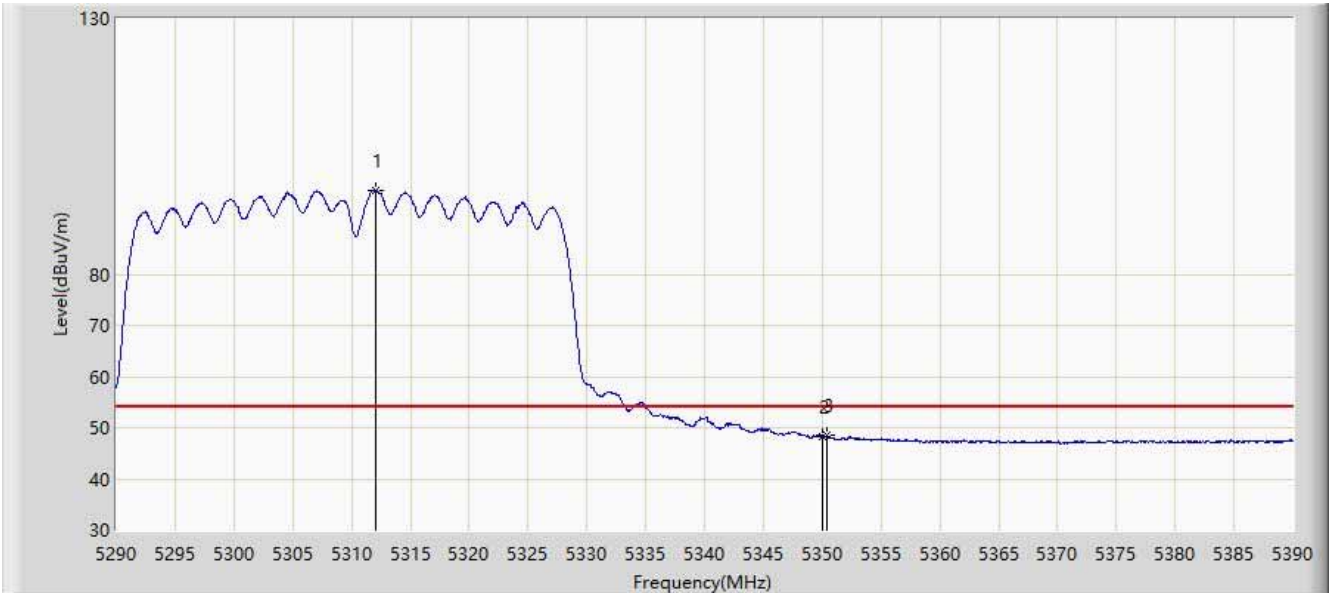

No	Flag	Mark	Frequency (MHz)	Measure Level (dB μ V/m)	Reading Level (dB μ V)	Margin (dB)	Limit (dB μ V/m)	Factor (dB)	Type
1		*	5312.050	96.349	105.663	N/A	N/A	-9.314	AV
2			5350.000	48.258	57.467	-5.742	54.000	-9.208	AV
3			5350.350	48.420	57.632	-5.580	54.000	-9.212	AV

Note: Measure Level (dB μ V/m) = Reading Level (dB μ V) + Factor (dB)

Factor (dB) = Cable Loss (dB) + Antenna Factor (dB/m) - Pre_Amplifier Gain (dB)

Site: SIP-AC3	Time: 2021/02/04 - 17:04
Limit: FCC_Part15_209 RE(3m)	Engineer: White Wang
Probe: SIP-AC3_HF907_102861_1-18GHz	Polarity: Vertical
EUT: Dual Band ONT #2	Power: AC 120V/60Hz
Test Mode: Transmit by 802.11n-HT40 at channel 5310MHz	

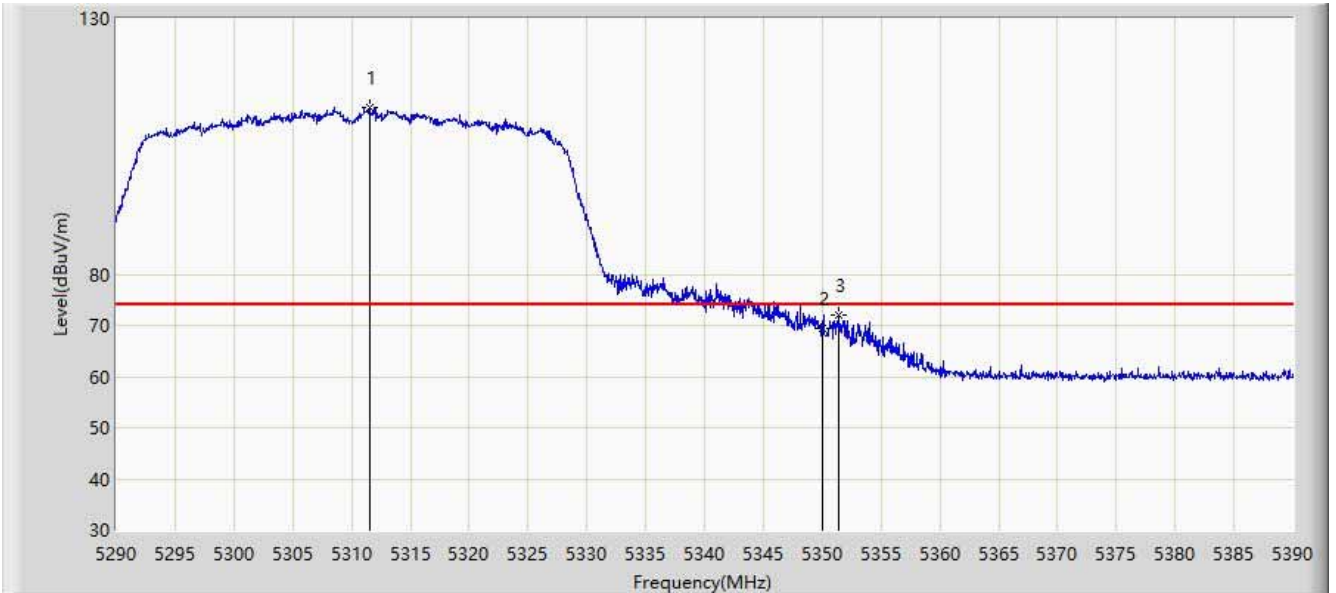

No	Flag	Mark	Frequency (MHz)	Measure Level (dB μ V/m)	Reading Level (dB μ V)	Margin (dB)	Limit (dB μ V/m)	Factor (dB)	Type
1		*	5311.550	112.539	121.861	N/A	N/A	-9.322	PK
2			5350.000	69.361	78.570	-4.639	74.000	-9.208	PK
3			5351.350	72.165	81.387	-1.835	74.000	-9.222	PK

Note: Measure Level (dB μ V/m) = Reading Level (dB μ V) + Factor (dB)

Factor (dB) = Cable Loss (dB) + Antenna Factor (dB/m) - Pre_Amplifier Gain (dB)

Site: SIP-AC3	Time: 2021/02/04 - 17:09
Limit: FCC_Part15_209 RE(3m)	Engineer: White Wang
Probe: SIP-AC3_HF907_102861_1-18GHz	Polarity: Vertical
EUT: Dual Band ONT #2	Power: AC 120V/60Hz
Test Mode: Transmit by 802.11n-HT40 at channel 5310MHz	

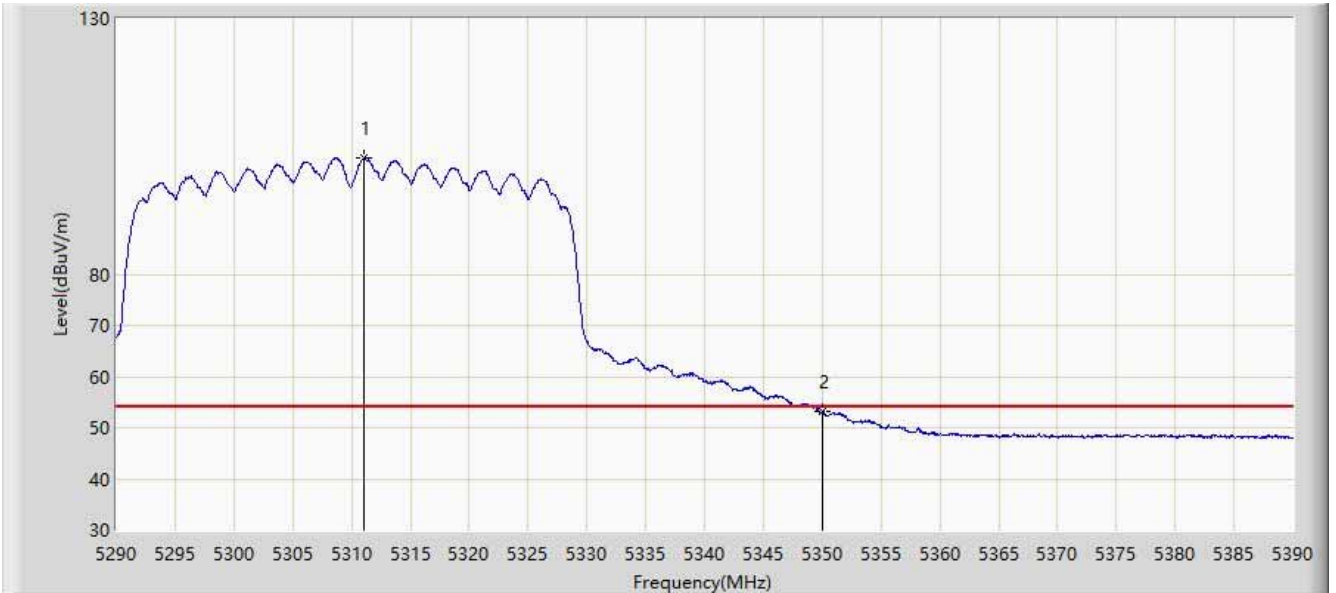

No	Flag	Mark	Frequency (MHz)	Measure Level (dBμV/m)	Reading Level (dBμV)	Margin (dB)	Limit (dBμV/m)	Factor (dB)	Type
1		*	5311.100	102.686	112.014	N/A	N/A	-9.328	AV
2			5350.000	53.221	62.430	-0.779	54.000	-9.208	AV

Note: Measure Level (dBμV/m) = Reading Level (dBμV) + Factor (dB)

Factor (dB) = Cable Loss (dB) + Antenna Factor (dB/m) - Pre_Amplifier Gain (dB)

Site: SIP-AC3	Time: 2021/02/04 - 17:27
Limit: FCC_Part15_209 RE(3m)	Engineer: White Wang
Probe: SIP-AC3_HF907_102861_1-18GHz	Polarity: Horizontal
EUT: Dual Band ONT #2	Power: AC 120V/60Hz
Test Mode: Transmit by 802.11n-HT40 at channel 5510MHz	

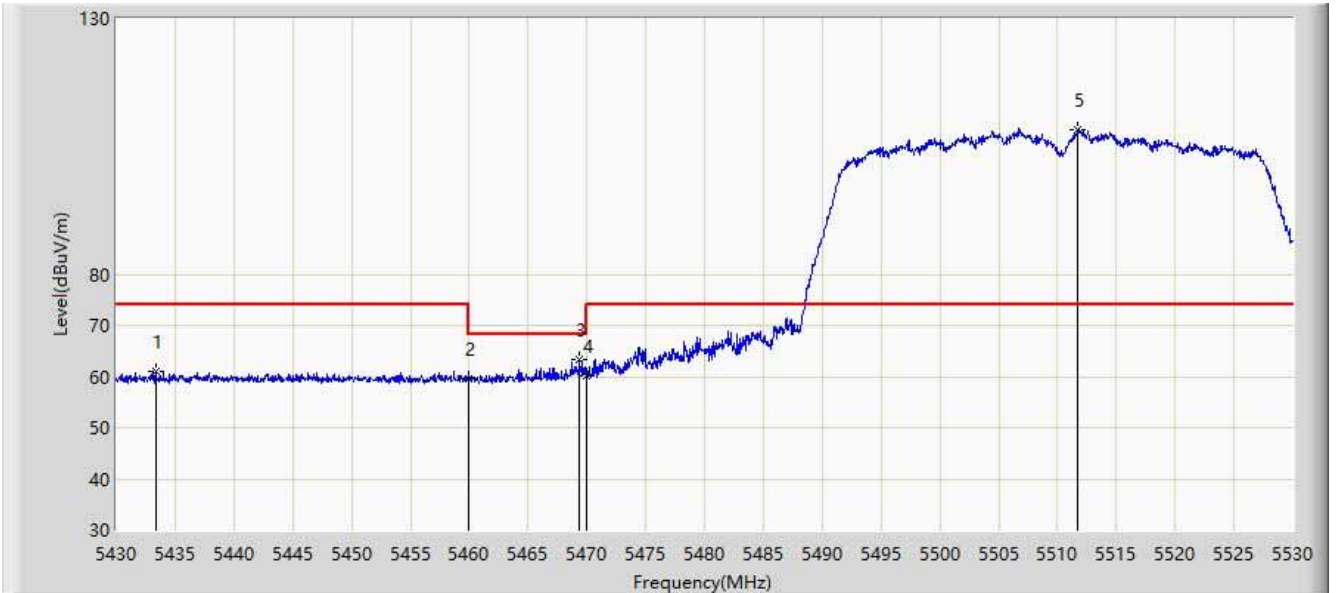

No	Flag	Mark	Frequency (MHz)	Measure Level (dB μ V/m)	Reading Level (dB μ V)	Margin (dB)	Limit (dB μ V/m)	Factor (dB)	Type
1			5433.350	61.139	70.046	-12.861	74.000	-8.908	PK
2			5460.000	59.637	68.615	-14.363	74.000	-8.979	PK
3			5469.400	63.426	72.513	-4.774	68.200	-9.087	PK
4			5470.000	60.105	69.199	-8.095	68.200	-9.094	PK
5		*	5511.700	108.132	117.013	N/A	N/A	-8.881	PK

Note: Measure Level (dB μ V/m) = Reading Level (dB μ V) + Factor (dB)

Factor (dB) = Cable Loss (dB) + Antenna Factor (dB/m) - Pre_Amplifier Gain (dB)

Site: SIP-AC3	Time: 2021/02/04 - 17:33
Limit: FCC_Part15_209 RE(3m)	Engineer: White Wang
Probe: SIP-AC3_HF907_102861_1-18GHz	Polarity: Horizontal
EUT: Dual Band ONT #2	Power: AC 120V/60Hz
Test Mode: Transmit by 802.11n-HT40 at channel 5510MHz	

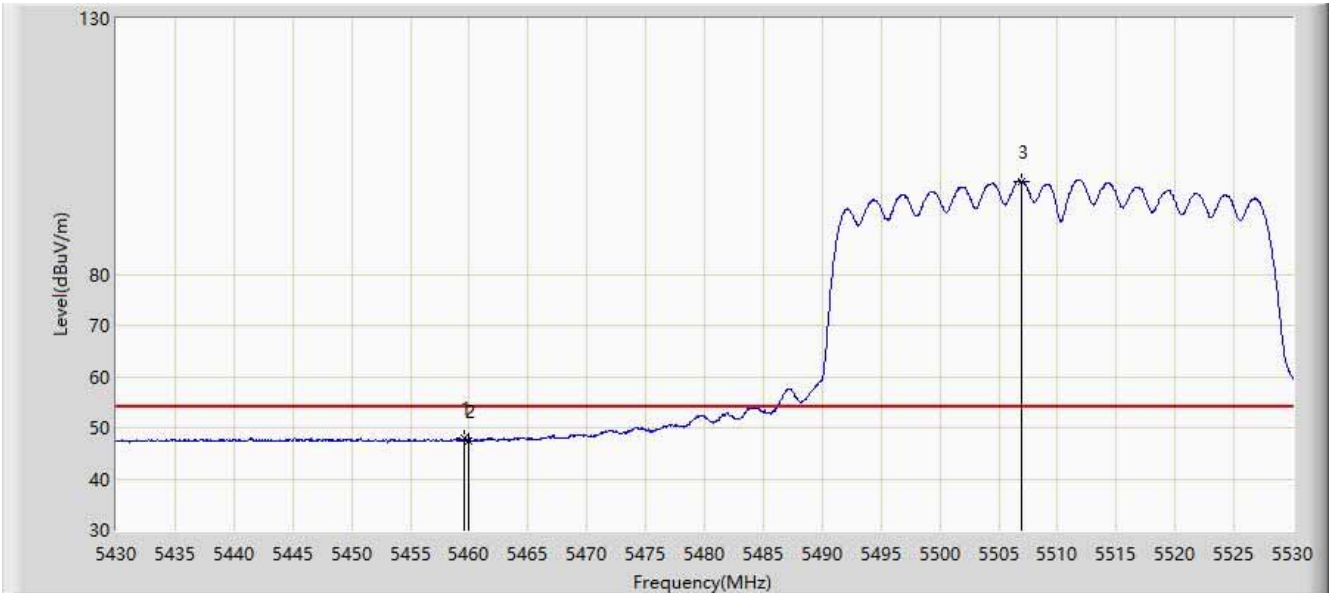

No	Flag	Mark	Frequency (MHz)	Measure Level (dB μ V/m)	Reading Level (dB μ V)	Margin (dB)	Limit (dB μ V/m)	Factor (dB)	Type
1			5459.550	47.829	56.802	-6.171	54.000	-8.973	AV
2			5460.000	47.493	56.471	-6.507	54.000	-8.979	AV
3		*	5506.950	98.209	107.024	N/A	N/A	-8.814	AV

Note: Measure Level (dB μ V/m) = Reading Level (dB μ V) + Factor (dB)

Factor (dB) = Cable Loss (dB) + Antenna Factor (dB/m) - Pre_Amplifier Gain (dB)

Site: SIP-AC3	Time: 2021/02/04 - 17:20
Limit: FCC_Part15_209 RE(3m)	Engineer: White Wang
Probe: SIP-AC3_HF907_102861_1-18GHz	Polarity: Vertical
EUT: Dual Band ONT #2	Power: AC 120V/60Hz
Test Mode: Transmit by 802.11n-HT40 at channel 5510MHz	

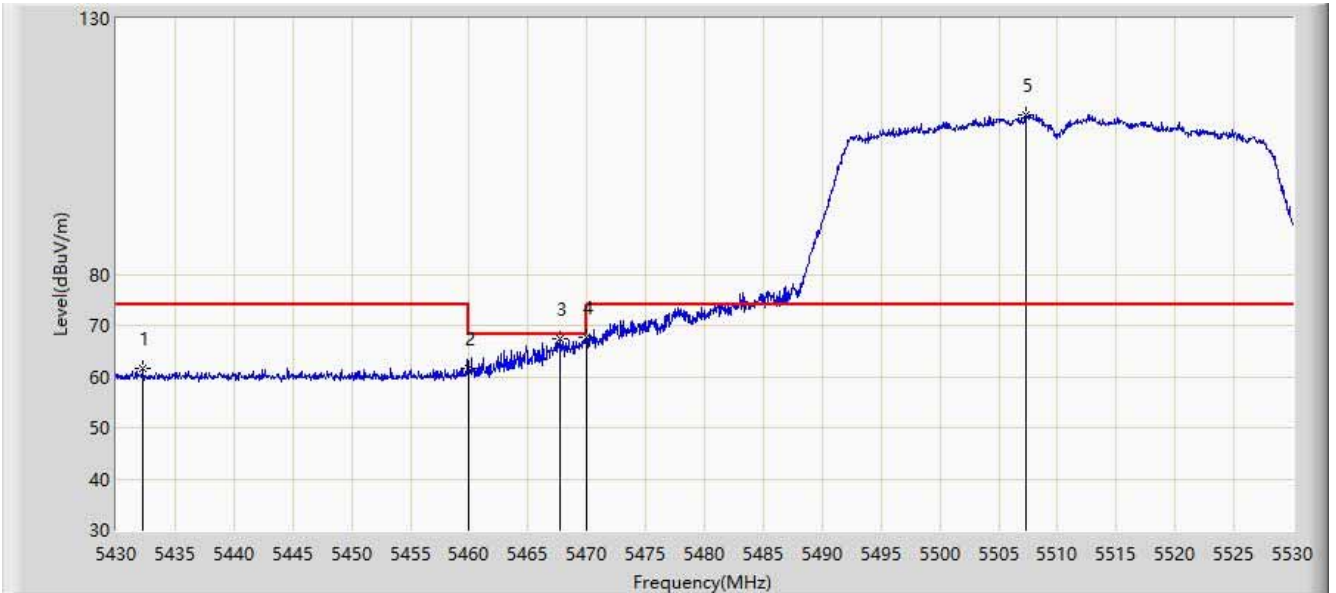

No	Flag	Mark	Frequency (MHz)	Measure Level (dBμV/m)	Reading Level (dBμV)	Margin (dB)	Limit (dBμV/m)	Factor (dB)	Type
1			5432.300	61.585	70.504	-12.415	74.000	-8.919	PK
2			5460.000	61.533	70.511	-12.467	74.000	-8.979	PK
3			5467.700	67.251	76.319	-0.949	68.200	-9.068	PK
4			5470.000	67.626	76.720	-0.574	68.200	-9.094	PK
5		*	5507.350	111.077	119.897	N/A	N/A	-8.821	PK

Note: Measure Level (dBμV/m) = Reading Level (dBμV) + Factor (dB)

Factor (dB) = Cable Loss (dB) + Antenna Factor (dB/m) - Pre_Amplifier Gain (dB)

Site: SIP-AC3	Time: 2021/02/04 - 17:24
Limit: FCC_Part15_209 RE(3m)	Engineer: White Wang
Probe: SIP-AC3_HF907_102861_1-18GHz	Polarity: Vertical
EUT: Dual Band ONT #2	Power: AC 120V/60Hz
Test Mode: Transmit by 802.11n-HT40 at channel 5510MHz	

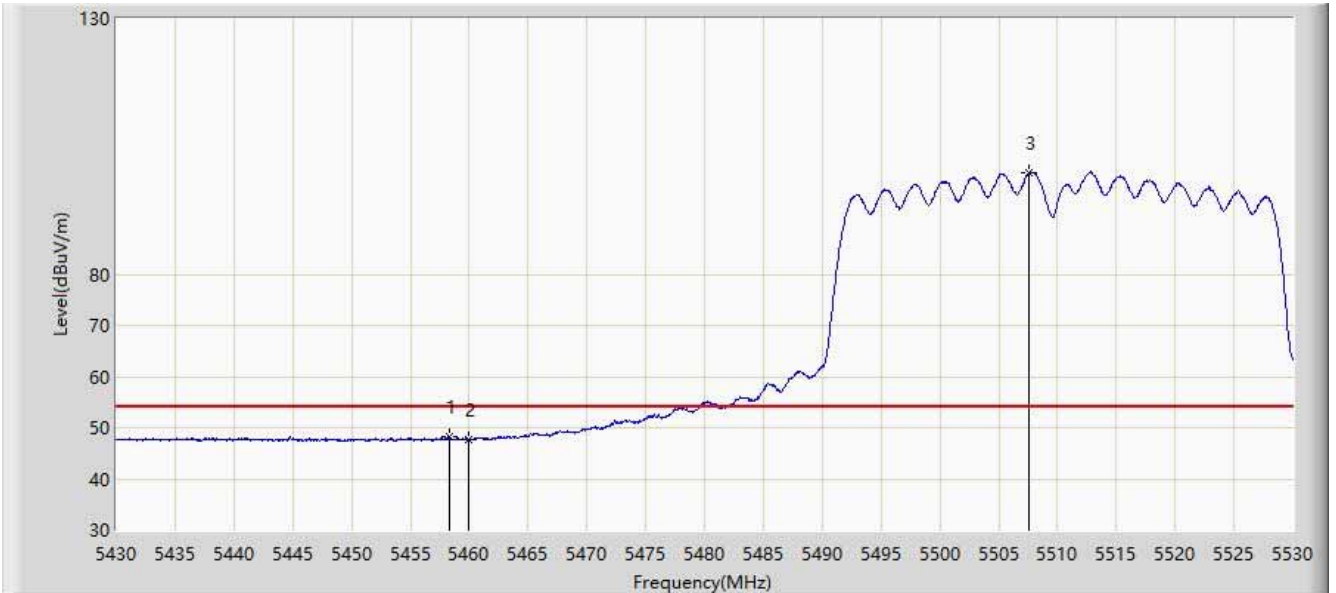

No	Flag	Mark	Frequency (MHz)	Measure Level (dBμV/m)	Reading Level (dBμV)	Margin (dB)	Limit (dBμV/m)	Factor (dB)	Type
1			5458.300	48.209	57.167	-5.791	54.000	-8.959	AV
2			5460.000	47.725	56.703	-6.275	54.000	-8.979	AV
3		*	5507.600	99.739	108.563	N/A	N/A	-8.824	AV

Note: Measure Level (dBμV/m) = Reading Level (dBμV) + Factor (dB)

Factor (dB) = Cable Loss (dB) + Antenna Factor (dB/m) - Pre_Amplifier Gain (dB)

Site: SIP-AC3	Time: 2021/02/20 - 10:31
Limit: FCC_Part15_209 RE(3m)	Engineer: White Wang
Probe: SIP-AC3_HF907_102861_1-18GHz	Polarity: Horizontal
EUT: Dual Band ONT	Power: AC 120V/60Hz
Test Mode: Transmit by 802.11n-HT40 at channel 5670MHz	

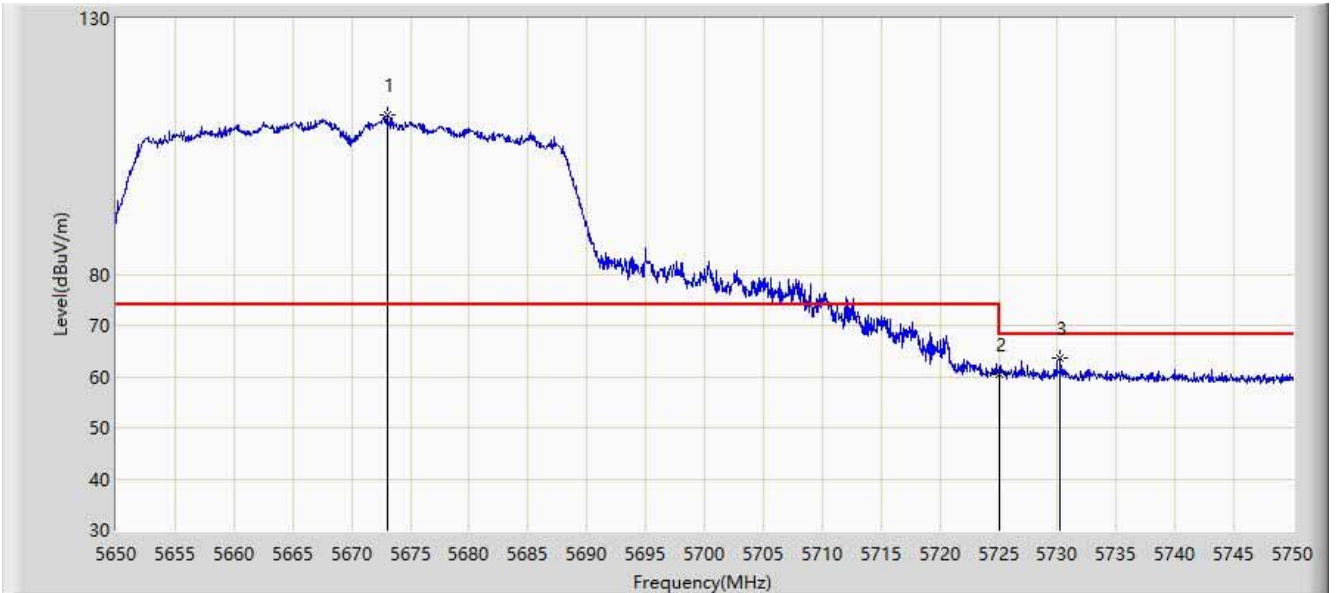

No	Flag	Mark	Frequency (MHz)	Measure Level (dB μ V/m)	Reading Level (dB μ V)	Margin (dB)	Limit (dB μ V/m)	Factor (dB)	Type
1		*	5673.000	111.110	120.286	N/A	N/A	-9.177	PK
2			5725.000	60.332	69.383	-7.868	68.200	-9.051	PK
3			5730.250	63.579	72.683	-4.621	68.200	-9.104	PK

Note: Measure Level (dB μ V/m) = Reading Level (dB μ V) + Factor (dB)

Factor (dB) = Cable Loss (dB) + Antenna Factor (dB/m) - Pre_Amplifier Gain (dB)