



**FCC 47 CFR PART 15 Subpart C**

**TEST REPORT**

**For**

**Home Monitoring Gateway**

**Model: NA910**

**Trade Name: SerComm**

*Issued to*

**SerComm Corporation  
8F, No.3-1, YuanQu St., NanKang,  
Taipei 115, Taiwan, R.O.C.**

*Issued by*

**Compliance Certification Services Inc.  
No.11, Wugong 6th Rd., Wugu Dist.,  
Xinbei City 24891, Taiwan  
<http://www.ccsrf.com>  
[service@ccsrf.com](mailto:service@ccsrf.com)**



---

**Note:** This report shall not be reproduced except in full, without the written approval of Compliance Certification Services Inc. This document may be altered or revised by Compliance Certification Services Inc. personnel only, and shall be noted in the revision section of the document.



## TABLE OF CONTENTS

|   |    |
|---|----|
| 1. TEST RESULT CERTIFICATION.....                       | 3  |
| 2. EUT DESCRIPTION.....                                 | 4  |
| 3. TEST METHODOLOGY .....                               | 5  |
| 3.1 EUT CONFIGURATION .....                             | 5  |
| 3.2 EUT EXERCISE.....                                   | 5  |
| 3.3 GENERAL TEST PROCEDURES.....                        | 5  |
| 3.4 FCC PART 15.205 RESTRICTED BANDS OF OPERATIONS..... | 6  |
| 3.5 DESCRIPTION OF TEST MODES .....                     | 6  |
| 4. INSTRUMENT CALIBRATION.....                          | 7  |
| 4.1 MEASURING INSTRUMENT CALIBRATION .....              | 7  |
| 4.2 MEASUREMENT EQUIPMENT USED .....                    | 7  |
| 4.3 MEASUREMENT UNCERTAINTY .....                       | 9  |
| 5. FACILITIES AND ACCREDITATIONS .....                  | 10 |
| 5.1 FACILITIES .....                                    | 10 |
| 5.2 EQUIPMENT.....                                      | 10 |
| 5.3 TABLE OF ACCREDITATIONS AND LISTINGS.....           | 11 |
| 6. SETUP OF EQUIPMENT UNDER TEST .....                  | 12 |
| 6.1 SETUP CONFIGURATION OF EUT.....                     | 12 |
| 6.2 SUPPORT EQUIPMENT .....                             | 12 |
| 7. FCC PART 15.249 REQUIREMENTS .....                   | 13 |
| 7.1 20 DB BANDWIDTH.....                                | 13 |
| 7.2 SPURIOUS EMISSION .....                             | 15 |
| 7.3 POWERLINE CONDUCTED EMISSIONS .....                 | 21 |
| APPENDIX I PHOTOGRAPHS OF TEST SETUP .....              | 24 |
| APPENDIX 1 - PHOTOGRAPHS OF EUT                         |    |



# 1. TEST RESULT CERTIFICATION

**Applicant:** SerComm Corporation  
8F, No.3-1, YuanQu St., NanKang,  
Taipei 115, Taiwan, R.O.C.

**Equipment Under Test:** Home Monitoring Gateway

**Trade Name:** SerComm

**Model:** NA910

**Date of Test:** December 2, 2010 ~ January 25, 2011

| APPLICABLE STANDARDS         |                         |
|------------------------------|-------------------------|
| STANDARD                     | TEST RESULT             |
| FCC 47 CFR Part 15 Subpart C | No non-compliance noted |

### We hereby certify that:

The above equipment was tested by Compliance Certification Services Inc. The test data, data evaluation, test procedures, and equipment configurations shown in this report were made in accordance with the procedures given in ANSI C63.4: 2003 and the energy emitted by the sample EUT tested as described in this report is in compliance with the requirements emission limits of FCC Rules Part 15.107, 15.109, 15.207, 15.209 and 15.249.

The test results of this report relate only to the tested sample identified in this report.

Approved by:

Reviewed by:

---

Rex Lai  
Section Manager  
Compliance Certification Services Inc.

---

Gina Lo  
Section Manager  
Compliance Certification Services Inc.



## 2. EUT DESCRIPTION

|                             |   |
|-----------------------------|---|
| <b>Product</b>              | Home Monitoring Gateway   |
| <b>Trade Name</b>           | SerComm   |
| <b>Model Number</b>         | NA910   |
| <b>Model Discrepancy</b>    | N/A   |
| <b>Power Adapter</b>        | 1. LEADER/ MU12-G120100-A1<br>I/P: 100-240V, 50-60Hz, 0.5A<br>O/P: DC 12 V, 1.0 A<br>2. Sunny/ SYS1381-1212-W2<br>I/P: 100-240V, 50-60Hz, 0.5A<br>O/P: DC 12 V, 1.0 A |
| <b>Frequency Range</b>      | Z-WAVE: 908MHz  |
| <b>Modulation Technique</b> | Z-WAVE: FSK   |
| <b>Antenna Gain</b>         | Z-WAVE: 2.21dBi   |
| <b>Antenna Designation</b>  | Z-WAVE: PCB Antenna   |

**Remark:**

1. The sample selected for test was production product and was provided by manufacturer.
2. This submittal(s) (test report) is intended for FCC ID: **P27NA910A** filing to comply with Section 15.207, 15.209 and 15.247 of the FCC Part 15, Subpart C Rules.



### **3. TEST METHODOLOGY**

The tests documented in this report were performed in accordance with ANSI C63.4 and FCC CFR 47 2.1046, 2.1047, 2.1049, 2.1051, 2.1053, 2.1055, 2.1057, 15.207, 15.209 and 15.249.

#### **3.1 EUT CONFIGURATION**

The EUT configuration for testing is installed on RF field strength measurement to meet the Commissions requirement and operating in a manner that intends to maximize its emission characteristics in a continuous normal application.

#### **3.2 EUT EXERCISE**

The EUT was operated in the engineering mode to fix the TX frequency that was for the purpose of the measurements.

According to its specifications, the EUT must comply with the requirements of the Section 15.107 and 15.109 under the FCC Rules Part 15 Subpart B and Section 15.207, 15.209, 15.249 under the FCC Rules Part 15 Subpart C.

#### **3.3 GENERAL TEST PROCEDURES**

##### **Conducted Emissions**

The EUT is placed on the turntable, which is 0.8 m above ground plane. According to the requirements in Section 13.1.4.1 of ANSI C63.4 Conducted emissions from the EUT measured in the frequency range between 0.15 MHz and 30MHz using CISPR Quasi-peak and average detector modes.

##### **Radiated Emissions**

The EUT is placed on a turn table, which is 0.8 m above ground plane. The turntable shall rotate 360 degrees to determine the position of maximum emission level. EUT is set 3m away from the receiving antenna, which varied from 1m to 4m to find out the highest emission. And also, each emission was to be maximized by changing the polarization of receiving antenna both horizontal and vertical. In order to find out the maximum emissions, exploratory radiated emission measurements were made according to the requirements in Section 13.1.4.1 of ANSI C63.4.



### 3.4 FCC PART 15.205 RESTRICTED BANDS OF OPERATIONS

(a) Except as shown in paragraph (d) of this section, only spurious emissions are permitted in any of the frequency bands listed below:

| MHz                        | MHz                 | MHz             | GHz              |
|----------------------------|---------------------|-----------------|------------------|
| 0.090 - 0.110              | 16.42 - 16.423      | 399.9 - 410     | 4.5 - 5.15       |
| <sup>1</sup> 0.495 - 0.505 | 16.69475 - 16.69525 | 608 - 614       | 5.35 - 5.46      |
| 2.1735 - 2.1905            | 16.80425 - 16.80475 | 960 - 1240      | 7.25 - 7.75      |
| 4.125 - 4.128              | 25.5 - 25.67        | 1300 - 1427     | 8.025 - 8.5      |
| 4.17725 - 4.17775          | 37.5 - 38.25        | 1435 - 1626.5   | 9.0 - 9.2        |
| 4.20725 - 4.20775          | 73 - 74.6           | 1645.5 - 1646.5 | 9.3 - 9.5        |
| 6.215 - 6.218              | 74.8 - 75.2         | 1660 - 1710     | 10.6 - 12.7      |
| 6.26775 - 6.26825          | 108 - 121.94        | 1718.8 - 1722.2 | 13.25 - 13.4     |
| 6.31175 - 6.31225          | 123 - 138           | 2200 - 2300     | 14.47 - 14.5     |
| 8.291 - 8.294              | 149.9 - 150.05      | 2310 - 2390     | 15.35 - 16.2     |
| 8.362 - 8.366              | 156.52475 -         | 2483.5 - 2500   | 17.7 - 21.4      |
| 8.37625 - 8.38675          | 156.52525           | 2655 - 2900     | 22.01 - 23.12    |
| 8.41425 - 8.41475          | 156.7 - 156.9       | 3260 - 3267     | 23.6 - 24.0      |
| 12.29 - 12.293             | 162.0125 - 167.17   | 3332 - 3339     | 31.2 - 31.8      |
| 12.51975 - 12.52025        | 167.72 - 173.2      | 3345.8 - 3358   | 36.43 - 36.5     |
| 12.57675 - 12.57725        | 240 - 285           | 3600 - 4400     | ( <sup>2</sup> ) |
| 13.36 - 13.41              | 322 - 335.4         |                 |                  |

<sup>1</sup> Until February 1, 1999, this restricted band shall be 0.490-0.510 MHz.

<sup>2</sup> Above 38.6

(b) Except as provided in paragraphs (d) and (e), the field strength of emissions appearing within these frequency bands shall not exceed the limits shown in Section 15.209. At frequencies equal to or less than 1000 MHz, compliance with the limits in Section 15.209 shall be demonstrated using measurement instrumentation employing a CISPR quasi-peak detector. Above 1000 MHz, compliance with the emission limits in Section 15.209 shall be demonstrated based on the average value of the measured emissions. The provisions in Section 15.35 apply to these measurements.

### 3.5 DESCRIPTION OF TEST MODES

The EUT (model: NA403) comes with two types of power adapter (MU12-G120100-A1 / SYS1381-1212-W2) for sale. After the preliminary test, the power adapter MU12-G120100-A1 was found to emit the worst emissions and therefore had been tested under operating condition.

After verification, all tests were carried out with the worst case test modes as shown below except radiated spurious emission below 1GHz, which worst case was in normal link mode only, and powerline conducted emission below 30MHz, which worst case was in normal link mode.



## 4. INSTRUMENT CALIBRATION

### 4.1 MEASURING INSTRUMENT CALIBRATION

The measuring equipment, which was utilized in performing the tests documented herein, has been calibrated in accordance with the manufacturer's recommendations for utilizing calibration equipment, which is traceable to recognized national standards.

### 4.2 MEASUREMENT EQUIPMENT USED

#### Equipment Used for Emissions Measurement

*Remark: Each piece of equipment is scheduled for calibration once a year and Loop Antenna is scheduled for calibration once three years.*

| Conducted Emissions Test Site |              |        |               |                 |
|-------------------------------|--------------|--------|---------------|-----------------|
| Name of Equipment             | Manufacturer | Model  | Serial Number | Calibration Due |
| Spectrum Analyzer             | Agilent      | E4446A | MY43360131    | 03/03/2011      |

| 3M Semi Anechoic Chamber |                    |                          |               |                 |
|--------------------------|--------------------|--------------------------|---------------|-----------------|
| Name of Equipment        | Manufacturer       | Model                    | Serial Number | Calibration Due |
| Spectrum Analyzer        | Agilent            | E4446A                   | US42510252    | 10/25/2011      |
| EMI Test Receiver        | R&S                | ESCI                     | 100064        | 02/04/2011      |
| Pre-Amplifier            | Mini-Circuits      | ZFL-1000LN               | SF350700823   | 01/12/2012      |
| Pre-Amplifier            | MITEQ              | AFS44-00102650-42-10P-44 | 1415367       | 11/19/2011      |
| Bilog Antenna            | Sunol Sciences     | JB3                      | A030105       | 09/10/2011      |
| Horn Antenna             | EMCO               | 3117                     | 00055165      | 12/06/2011      |
| Loop Antenna             | EMCO               | 6502                     | 8905/2356     | 06/10/2013      |
| Turn Table               | CCS                | CC-T-1F                  | N/A           | N.C.R           |
| Antenna Tower            | CCS                | CC-A-1F                  | N/A           | N.C.R           |
| Controller               | CCS                | CC-C-1F                  | N/A           | N.C.R           |
| Site NSA                 | CCS                | N/A                      | N/A           | 12/30/2011      |
| Test S/W                 | EZ-EMC (CCS-3A1RE) |                          |               |                 |



| <b>Conducted Emission room # B</b> |                     |                  |                      |                        |
|------------------------------------|---------------------|------------------|----------------------|------------------------|
| <b>Name of Equipment</b>           | <b>Manufacturer</b> | <b>Model</b>     | <b>Serial Number</b> | <b>Calibration Due</b> |
| TEST RECEIVER                      | R&S                 | ESCI             | 100234               | 06/13/2011             |
| LISN (EUT)                         | FCC                 | FCC-LISN-50-32-2 | 08009                | 03/25/2011             |
| LISN                               | EMCO                | 3825/2           | 1382                 | 01/11/2011             |
| BNC CABLE                          | MIYAZAKI            | 5D-FB            | BNC B3               | 08/10/2011             |
| Pulse Limiter                      | R&S                 | ESH3-Z2          | 100374               | 08/19/2011             |
| THERMO-HYGRO METER                 | TOP                 | HA-202           | 9303-3               | 01/31/2011             |
| Test S/W                           | EZ-EMC              |                  |                      |                        |





### 4.3 MEASUREMENT UNCERTAINTY

| PARAMETER                             | UNCERTAINTY |
|---------------------------------------|-------------|
| Powerline Conducted Emission          | +/- 1.1089  |
| 3M Semi Anechoic Chamber / 30M~200M   | +/- 4.0606  |
| 3M Semi Anechoic Chamber / 200M~1000M | +/- 3.9979  |
| 3M Semi Anechoic Chamber / 1G~8G      | +/- 2.5790  |
| 3M Semi Anechoic Chamber / 8G~18G     | +/- 2.5928  |
| 3M Semi Anechoic Chamber / 18G~26G    | +/- 2.7212  |
| 3M Semi Anechoic Chamber / 26G~40G    | +/- 2.9520  |

**Remark:** This uncertainty represents an expanded uncertainty expressed at approximately the 95% confidence level using a coverage factor of  $k=2$ .



## 5. FACILITIES AND ACCREDITATIONS

### 5.1 FACILITIES

All measurement facilities used to collect the measurement data are located at

- No.199, Chunghsen Road, Hsintien City, Taipei Hsien, Taiwan, R.O.C.  
Tel: 886-2-2217-0894 / Fax: 886-2-2217-1029

**Remark:** The radiated emissions test items was tested at Compliance Certification Services Inc. (Sindian Lab.)  
The test equipments were listed in page 8 and the test data, please refer page 22-23.

- No.11, Wugong 6th Rd., Wugu Industrial Park, Taipei Hsien 248, Taiwan  
Tel: 886-2-2299-9720 / Fax: 886-2-2298-4045

- No.81-1, Lane 210, Bade 2nd Rd., Luchu Hsiang, Taoyuan Hsien 338, Taiwan  
Tel: 886-3-324-0332 / Fax: 886-3-324-5235

The sites are constructed in conformance with the requirements of ANSI C63.7, ANSI C63.4 and CISPR Publication 22.

### 5.2 EQUIPMENT

Radiated emissions are measured with one or more of the following types of linearly polarized antennas: tuned dipole, biconical, log periodic, bi-log, and/or ridged waveguide, horn. Spectrum analyzers with pre-selectors and quasi-peak detectors are used to perform radiated measurements.



Conducted emissions are measured with Line Impedance Stabilization Networks and EMI Test Receivers.

Calibrated wideband preamplifiers, coaxial cables, and coaxial attenuators are also used for making measurements.

All receiving equipment conforms to CISPR Publication 16-1, "Radio Interference Measuring Apparatus and Measurement Methods."



### 5.3 TABLE OF ACCREDITATIONS AND LISTINGS

| Country | Agency          | Scope of Accreditation   | Logo  |
|---------|-----------------|--|---|
| USA     | FCC             | 3M Semi Anechoic Chamber (FCC MRA: TW1039) to perform FCC Part 15 measurements   | <br>FCC MRA: TW1039          |
| Taiwan  | TAF             | LP0002, RTTE01, FCC Method-47 CFR Part 15 Subpart C, D, E, RSS-210, RSS-310<br>IDA TS SRD, AS/NZS 4268, AS/NZS 4771, TS 12.1 & 12.2, ETSI EN 300 440-1, ETSI EN 300 440-2, ETSI EN 300 328, ETSI EN 300 220-1, ETSI EN 300 220-2, ETSI EN 301 893, ETSI EN 301 489-1/3/7/17<br>FCC OET Bulletin 65 + Supplement C,<br>EN 50360, EN 50361, EN 50371, RSS 102, EN 50383, EN 50385, EN 50392, IEC 62209, CNS 14958-1, CNS 14959<br>FCC Method -47 CFR Part 15 Subpart B<br>IEC / EN 61000-3-2, IEC / EN 61000-3-3,<br>IEC / EN 61000-4-2/3/4/5/6/8/11 |                              |
| Canada  | Industry Canada | 3M Semi Anechoic Chamber (IC 2324G-1 / IC 2324G-2) to perform  | <br>IC 2324G-1<br>IC 2324G-2 |

*\* No part of this report may be used to claim or imply product endorsement by A2LA or any agency of the US Government.*



## 6. SETUP OF EQUIPMENT UNDER TEST

### 6.1 SETUP CONFIGURATION OF EUT

See test photographs attached in Appendix I for the actual connections between EUT and support equipment.

### 6.2 SUPPORT EQUIPMENT

| No. | Device Type           | Brand   | Model        | Series No. | FCC ID               | Data Cable                       | Power Cord       |
|-----|-----------------------|---------|--------------|------------|----------------------|----------------------------------|------------------|
| 1   | Earphone & Microphone | e-Sense | MSB301       | N/A        | N/A                  | Unshielded, 1.7m                 | N/A              |
| 2   | USB 2.0 HDD           | TeraSys | F12-U        | N/A        | BSMI ID:<br>4912A002 | Shielded, 1.8m                   | N/A              |
| 3   | iPOD                  | Apple   | A1112        | N/A        | R33057               | Shielded, 1.0m                   | N/A              |
| 4   | iPOD                  | Apple   | A1112        | N/A        | R33057               | Shielded, 1.0m                   | N/A              |
| 5   | USB Mouse             | DELL    | MO56UC       | 443007221  | DOC<br>BSMI: R41108  | Shielded, 1.8m                   | N/A              |
| 6   | USB Keyboard          | DELL    | SK-8115      | N/A        | DOC<br>BSMI: T3A002  | Shielded, 1.8m<br>with a core    | N/A              |
| 7   | Notebook              | HP      | Compaq 2210b | CNU7472KDP | N/A                  | Unshielded, 1.0m                 | Unshielded, 1.8m |
| 8   | Monitor               | SAMSUNG | 933SN+       | N/A        | DOC<br>BSMI: R33475  | Shielded, 1.8m<br>with two cores | Unshielded, 1.8m |
| 9   | Server PC             | HP      | HD075AV      | SGH948QGVW | DOC<br>BSMI: R33001  | Unshielded, 20m                  | Unshielded, 1.8m |
| 10  | LAN Cable             | N/A     | N/A          | N/A        | N/A                  | N/A                              | N/A              |

**Remark:**

1. All the equipment/cables were placed in the worst-case configuration to maximize the emission during the test.
2. Grounding was established in accordance with the manufacturer's requirements and conditions for the intended use.



## 7. FCC PART 15.249 REQUIREMENTS

### 7.120 DB BANDWIDTH

#### LIMIT

None; for reporting purposes only.

#### Test Configuration

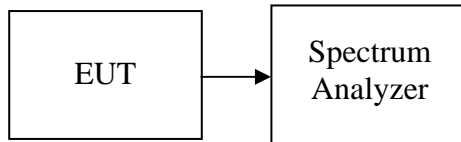

#### TEST PROCEDURE

1. Place the EUT on the table and set it in the transmitting mode.
2. Remove the antenna from the EUT and then connect a low loss RF cable from the antenna port to the spectrum analyzer.
3. Set the spectrum analyzer as RBW=10kHz, VBW = 30kHz, Span = 500kHz, Sweep = auto.
4. Mark the peak frequency and 20dB (upper and lower) frequency.
5. Repeat until all the rest channels are investigated.

#### TEST RESULTS

*No non-compliance noted*

#### Test Data

| Frequency (MHz) | 20dB Bandwidth (kHz) |
|-----------------|----------------------|
| 908             | 97.3                 |



**Test Plot**

Agilent 14:59:45 Jan 25, 2011

R T

Δ Mkr2 120.7 kHz

-1.44 dB

Ref 10 dBm

#Atten 20 dB

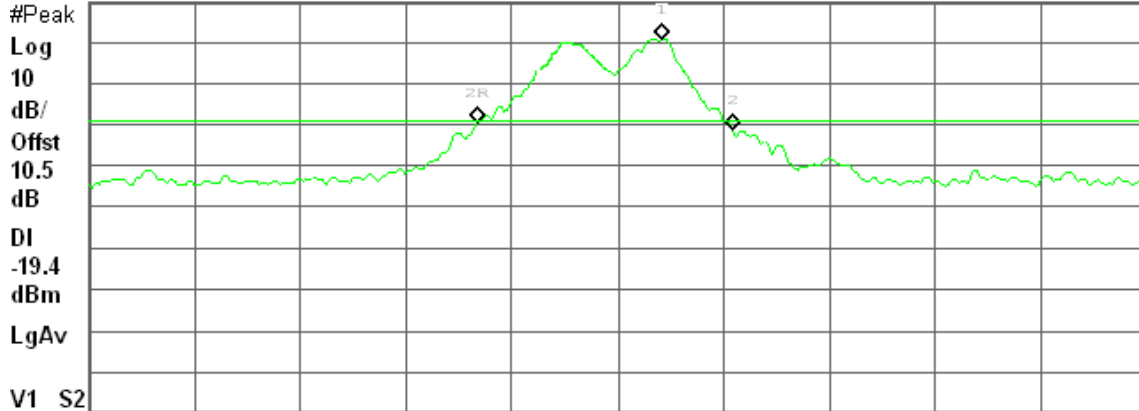

Center 908.416 6 MHz

Span 500 kHz

#Res BW 10 kHz

#VBW 30 kHz

Sweep 4.8 ms (601 pts)

| Marker | Trace | Type | X Axis        | Amplitude  |
|--------|-------|------|---------------|------------|
| 1      | (1)   | Freq | 908.437 8 MHz | 0.57 dBm   |
| 2R     | (1)   | Freq | 908.342 5 MHz | -20.73 dBm |
| 2Δ     | (1)   | Freq | 120.7 kHz     | -1.44 dB   |



## 7.2 SPURIOUS EMISSION

### LIMIT

1. In the section 15.249(a):

Except as provided in paragraph (b) of this section, the field strength of emissions from intentional radiators operated within these frequency bands shall comply with the following:

| Fundamental Frequency (MHz) | Field Strength of Fundamental Field Strength (mV/m) | Field Strength of Harmonics (µV/m) |
|-----------------------------|---|------------------------------------|
| 902-928 MHz                 | 50  | 500                                |
| 2400 - 2483.5 MHz           | 50  | 500                                |
| 5725 - 5875 MHz             | 50  | 500                                |
| 24.0 - 24.25 GHz            | 250   | 2500                               |

2. Except as provided elsewhere in this Subpart, the emissions from an intentional radiator shall not exceed the field strength levels specified in the following table:

| Frequency (MHz) | Field Strength (µV/m) | Measurement Distance (m) |
|-----------------|-----------------------|--------------------------|
| 30-88           | 100*                  | 3                        |
| 88-216          | 150*                  | 3                        |
| 216-960         | 200*                  | 3                        |
| Above 960       | 500                   | 3                        |

**Remark:** Except as provided in paragraph (g), fundamental emissions from intentional radiators operating under this Section shall not be located in the frequency bands 54-72 MHz, 76-88 MHz, 174-216 MHz or 470-806 MHz. However, operation within these frequency bands is permitted under other sections of this Part, e.g., Sections 15.231 and 15.241.

3. In the above emission table, the tighter limit applies at the band edges.

| Frequency (MHz) | Field Strength (µV/m at 3-meter) | Field Strength (dBµV/m at 3-meter) |
|-----------------|----------------------------------|------------------------------------|
| 30-88           | 100                              | 40                                 |
| 88-216          | 150                              | 43.5                               |
| 216-960         | 200                              | 46                                 |
| Above 960       | 500                              | 54                                 |



**Test Configuration**

**9kHz ~ 30MHz**

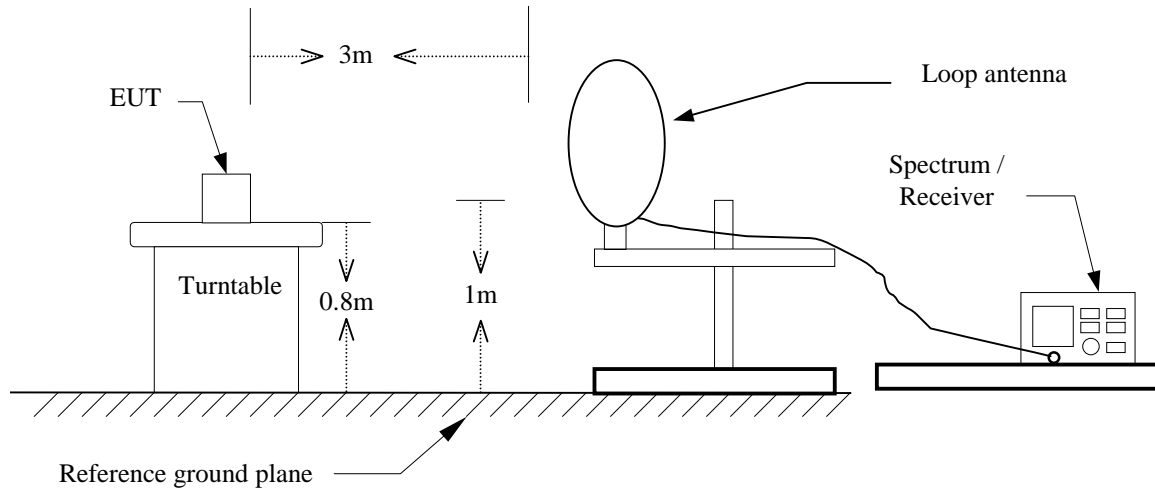

**30MHz ~ 1GHz**

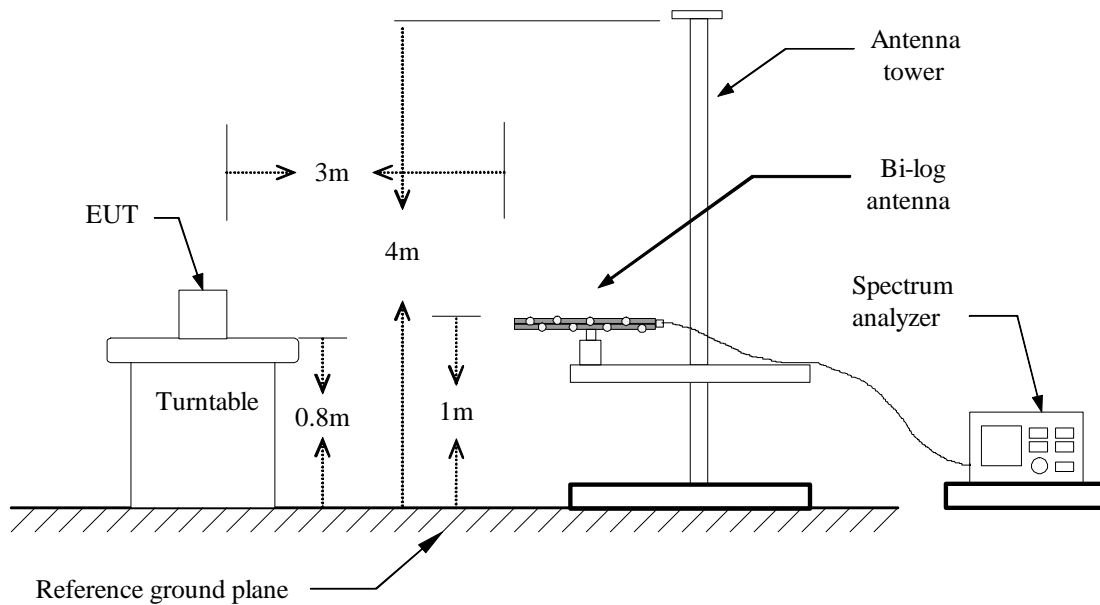





Above 1 GHz

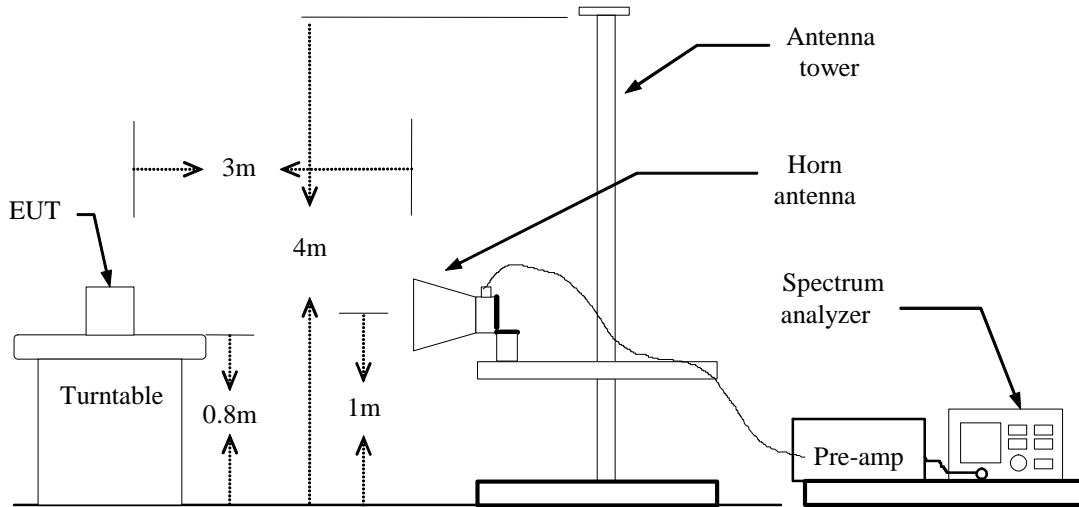



## **TEST PROCEDURE**

1. The EUT is placed on a turntable, which is 0.8m above ground plane.
2. The turntable shall be rotated for 360 degrees to determine the position of maximum emission level.
3. EUT is set 3m away from the receiving antenna, which is varied from 1m to 4m to find out the highest emissions.
4. Maximum procedure was performed on the six highest emissions to ensure EUT compliance.
5. And also, each emission was to be maximized by changing the polarization of receiving antenna both horizontal and vertical.
6. Set the spectrum analyzer in the following setting as:  
Below 1GHz:  
    RBW=100kHz / VBW=300kHz / Sweep=AUTO  
Above 1GHz:  
    (a) PEAK: RBW=VBW=1MHz / Sweep=AUTO  
    (b) AVERAGE: RBW=1MHz / VBW=10Hz / Sweep=AUTO
7. Repeat above procedures until the measurements for all frequencies are complete.



**Below 1 GHz**

**Operation Mode:** Normal Link

**Test Date:** December 14, 2010

**Temperature:** 20°C

**Tested by:** Wolf Huang

**Humidity:** 45 % RH

**Polarity:** Ver. / Hor.

| Frequency (MHz) | Reading (dBuV) | Correction Factor (dB/m) | Result (dBuV/m) | Limit (dBuV/m) | Margin (dB) | Ant.Pol. (H/V) | Remark |
|-----------------|----------------|--------------------------|-----------------|----------------|-------------|----------------|--------|
| 38.08           | 37.46          | -7.79                    | 29.67           | 40.00          | -10.33      | V              | Peak   |
| 68.80           | 43.77          | -14.76                   | 29.01           | 40.00          | -10.99      | V              | Peak   |
| 246.63          | 41.76          | -10.96                   | 30.79           | 46.00          | -15.21      | V              | Peak   |
| 371.12          | 41.61          | -7.64                    | 33.97           | 46.00          | -12.03      | V              | Peak   |
| 518.23          | 34.69          | -4.90                    | 29.79           | 46.00          | -16.21      | V              | Peak   |
| 647.57          | 29.49          | -2.95                    | 26.54           | 46.00          | -19.46      | V              | Peak   |
| 143.17          | 33.84          | -10.00                   | 23.83           | 43.50          | -19.67      | H              | Peak   |
| 261.18          | 46.19          | -10.15                   | 36.04           | 46.00          | -9.96       | H              | Peak   |
| 364.65          | 45.56          | -7.77                    | 37.79           | 46.00          | -8.21       | H              | Peak   |
| 419.62          | 36.30          | -6.61                    | 29.69           | 46.00          | -16.31      | H              | QP     |
| 484.28          | 31.31          | -5.37                    | 25.94           | 46.00          | -20.06      | H              | Peak   |
| 624.93          | 33.85          | -3.48                    | 30.38           | 46.00          | -15.62      | H              | QP     |

**Remark:**

1. No emission found between lowest internal used/generated frequency to 30MHz (9kHz~30MHz).
2. Radiated emissions measured in frequency range from 30 MHz to 1000MHz were made with an instrument using peak/quasi-peak detector mode.
3. Quasi-peak test would be performed if the peak result were greater than the quasi-peak limit or as required by the applicant.
4. Measurements above show only up to 6 maximum emissions noted, or would be lesser, with " N/A " remark, if no specific emissions from the EUT are recorded (ie: margin>20dB from the applicable limit) and considered that's already beyond the background noise floor.
5. Margin (dB) = Remark result (dBuV/m) – Quasi-peak limit (dBuV/m).



**Above 1 GHz**

**Operation Mode:** Tx / CH Low

**Test Date:** December 14, 2010

**Temperature:** 20°C

**Tested by:** Wolf Huang

**Humidity:** 45 % RH

**Polarity:** Ver. / Hor.

| Freq. (MHz) | Peak Reading (dBuV) | AV Reading (dBuV) | Ant. / CL CF (dB/m) | Result        |             | Peak Limit (dBuV/m) | AV Limit (dBuV/m) | Margin (dB) | Remark | Ant. Pol H/V |
|-------------|---------------------|-------------------|---------------------|---------------|-------------|---------------------|-------------------|-------------|--------|--------------|
|             |                     |                   |                     | Peak (dBuV/m) | AV (dBuV/m) |                     |                   |             |        |              |
| 908.40      | 71.72               | ---               | -0.48               | 71.24         | ---         | 94.00               | ---               | -22.76      | Peak   | V            |
| 1113.33     | 55.84               | ---               | -10.95              | 44.89         | ---         | 74.00               | 54.00             | -9.11       | Peak   | V            |
| 1440.00     | 55.10               | ---               | -10.61              | 44.49         | ---         | 74.00               | 54.00             | -9.51       | Peak   | V            |
| 1666.67     | 53.38               | ---               | -8.86               | 44.53         | ---         | 74.00               | 54.00             | -9.47       | Peak   | V            |
| 1816.67     | 53.50               | ---               | -7.33               | 46.16         | ---         | 74.00               | 54.00             | -7.84       | Peak   | V            |
| 2126.67     | 52.38               | ---               | -5.14               | 47.24         | ---         | 74.00               | 54.00             | -6.76       | Peak   | V            |
| 2726.67     | 52.33               | ---               | -3.10               | 49.23         | ---         | 74.00               | 54.00             | -4.77       | Peak   | V            |
| 908.40      | 81.15               | ---               | -0.48               | 80.68         | ---         | 94.00               | ---               | -13.32      | Peak   | H            |
| 1123.33     | 55.57               | ---               | -10.94              | 44.63         | ---         | 74.00               | 54.00             | -9.37       | Peak   | H            |
| 1440.00     | 58.97               | ---               | -10.61              | 48.35         | ---         | 74.00               | 54.00             | -5.65       | Peak   | H            |
| 1760.00     | 53.05               | ---               | -7.91               | 45.14         | ---         | 74.00               | 54.00             | -8.86       | Peak   | H            |
| 1816.67     | 55.40               | ---               | -7.33               | 48.07         | ---         | 74.00               | 54.00             | -5.93       | Peak   | H            |
| 2543.33     | 52.00               | ---               | -3.72               | 48.28         | ---         | 74.00               | 54.00             | -5.72       | Peak   | H            |
| 2726.67     | 57.60               | 49.17             | -3.10               | 54.50         | 46.07       | 74.00               | 54.00             | -7.93       | AVG    | H            |

**Remark:**

1. Measuring frequencies from 1 GHz to the 10th harmonic of highest fundamental frequency.
2. Radiated emissions measured in frequency above 1000MHz were made with an instrument using peak/average detector mode.
3. Average test would be performed if the peak result were greater than the average limit or as required by the applicant.
4. Data of measurement within this frequency range shown " --- " in the table above means the reading of emissions are attenuated more than 20dB below the permissible limits or the field strength is too small to be measured.
5. Measurements above show only up to 6 maximum emissions noted, or would be lesser, with " N/A " remark, if no specific emissions from the EUT are recorded (ie: margin > 20dB from the applicable limit) and considered that's already beyond the background noise floor.
6. Margin (dB) = Remark result (dBuV/m) – Average limit (dBuV/m). Peak detector mode and average detector mode of the emission shown in Result column.



## 7.3 POWERLINE CONDUCTED EMISSIONS

### LIMIT

According to §15.207(a), except as shown in paragraphs (b) and (c) of this section, for an intentional radiator that is designed to be connected to the public utility (AC) power line, the radio frequency voltage that is conducted back onto the AC power line on any frequency or frequencies within the band 150 kHz to 30 MHz shall not exceed the limits in the following table, as measured using a 50  $\mu$ H/50 ohms line impedance stabilization network (LISN). Compliance with the provisions of this paragraph shall be based on the measurement of the radio frequency voltage between each power line and ground at the power terminal. The lower limit applies at the boundary between the frequency ranges.

| Frequency Range<br>(MHz) | Limits<br>(dB $\mu$ V) |           |
|--------------------------|------------------------|-----------|
|                          | Quasi-peak             | Average   |
| 0.15 to 0.50             | 66 to 56*              | 56 to 46* |
| 0.50 to 5                | 56                     | 46        |
| 5 to 30                  | 60                     | 50        |

\* Decreases with the logarithm of the frequency.

### Test Configuration

See test photographs attached in Appendix I for the actual connections between EUT and support equipment.

### TEST PROCEDURE

1. The EUT was placed on a table, which is 0.8m above ground plane.
2. Maximum procedure was performed on the six highest emissions to ensure EUT compliance.
3. Repeat above procedures until all frequency measured were complete.



### TEST RESULTS

The initial step in collecting conducted data is a spectrum analyzer peak scan of the measurement range. Significant peaks are then marked as shown on the following data page, and these signals are then quasi-peaked.

#### Test Data

**Operation Mode:** Normal Link                      **Test Date:** December 2, 2010  
**Temperature:** 24°C                                      **Tested by:** John Yen  
**Humidity:** 60% RH

| Freq. (MHz) | QP Reading (dBuV) | AV Reading (dBuV) | Corr. factor (dB) | QP Result (dBuV) | AV Result (dBuV) | QP Limit (dBuV) | AV Limit (dBuV) | QP Margin (dB) | AV Margin (dB) | Note |
|-------------|-------------------|-------------------|-------------------|------------------|------------------|-----------------|-----------------|----------------|----------------|------|
| 0.1500      | 44.20             | 30.93             | 10.84             | 55.04            | 41.77            | 65.99           | 55.99           | -10.95         | -14.22         | L1   |
| 0.3339      | 29.82             | 18.71             | 10.74             | 40.56            | 29.45            | 59.35           | 49.35           | -18.79         | -19.90         | L1   |
| 0.3780      | 33.13             | 20.23             | 10.72             | 43.85            | 30.95            | 58.32           | 48.32           | -14.47         | -17.37         | L1   |
| 2.0300      | 18.56             | 8.68              | 10.68             | 29.24            | 19.36            | 56.00           | 46.00           | -26.76         | -26.64         | L1   |
| 7.8140      | 27.47             | 21.59             | 10.81             | 38.28            | 32.40            | 60.00           | 50.00           | -21.72         | -17.60         | L1   |
| 12.6380     | 30.02             | 22.82             | 10.96             | 40.98            | 33.78            | 60.00           | 50.00           | -19.02         | -16.22         | L1   |
| 0.1500      | 43.64             | 29.05             | 10.62             | 54.26            | 39.67            | 66.00           | 56.00           | -11.74         | -16.33         | L2   |
| 0.1668      | 41.67             | 28.80             | 10.63             | 52.30            | 39.43            | 65.12           | 55.12           | -12.82         | -15.69         | L2   |
| 0.3820      | 33.29             | 21.30             | 10.61             | 43.90            | 31.91            | 58.24           | 48.24           | -14.34         | -16.33         | L2   |
| 0.8340      | 22.98             | 13.95             | 10.62             | 33.60            | 24.57            | 56.00           | 46.00           | -22.40         | -21.43         | L2   |
| 7.7940      | 26.60             | 20.71             | 10.74             | 37.34            | 31.45            | 60.00           | 50.00           | -22.66         | -18.55         | L2   |
| 11.5260     | 31.16             | 23.57             | 10.85             | 42.01            | 34.42            | 60.00           | 50.00           | -17.99         | -15.58         | L2   |

**Remark:**

1. Measuring frequencies from 0.15 MHz to 30MHz.
2. The emissions measured in frequency range from 0.15 MHz to 30MHz were made with an instrument using Quasi-peak detector and average detector.
3. The IF bandwidth of SPN between 0.15MHz to 30MHz was 10kHz; the IF bandwidth of Test Receiver between 0.15MHz to 30MHz was 9kHz;
4. L1 = Line One (Live Line) / L2 = Line Two (Neutral Line)



### Test Plots

#### Conducted emissions (Line 1)

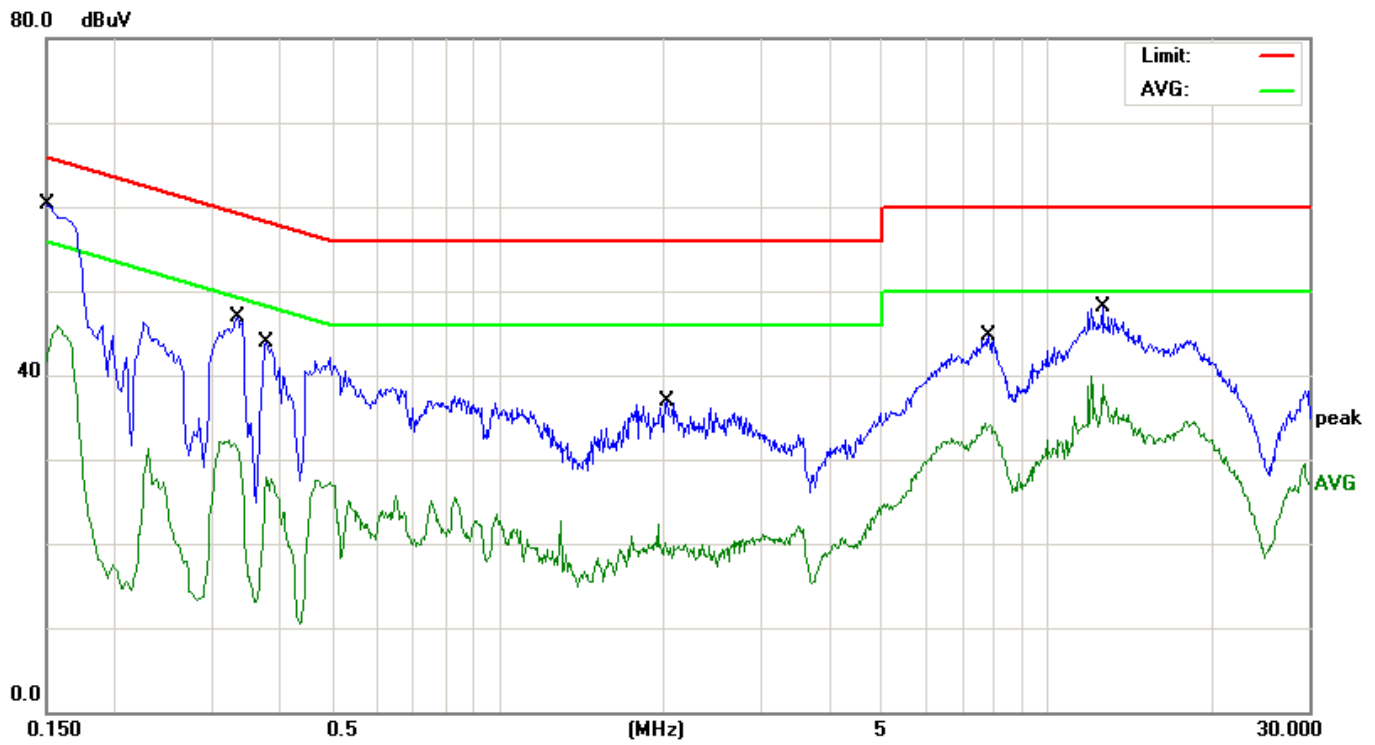

#### Conducted emissions (Line 2)

