

FCC TEST REPORT

according to

FCC Rules and Regulations

Part 15 Subpart E

Applicant	:	SerComm Corporation
Address	:	8F, No. 3-1, YuanQu St., NanKang, Taipei 115 Taiwan, R.O.C.
Equipment	:	802.11a+g Wireless Access Point
Model No.	:	AP51DA
FCC ID	:	P27AP51DAR
Trade Name	:	SerComm

Laboratory accreditation



- The test result refers exclusively to the test presented test model / sample.,
- The test result does not include DFS test for 5250 ~ 5350 MHz.
- Without written approval of **Exclusive Certification Corp.** the test report shall not be reproduced except in full.
- The EUT is also considered as a kind of computer peripheral, because the connection to computer is necessary for typical use. It has been verified to comply with the requirements of FCC Part 15, Subpart B, Class B (DoC). The test report has been issued separately.

CONTENTS

1.	Report of Measurements and Examinations.....	5
1.1.	List of Measurements and Examinations	5
2.	Test Configuration of Equipment under Test.....	6
2.1.	Feature of Equipment under Test.....	6
2.2.	RF Specifications	6
2.3.	Carrier Frequency of Channels	6
2.4.	Test Mode and Test Software.....	7
2.5.	Description of Test System.....	7
2.6.	Connection Diagram of Test System.....	8
2.7.	General Information of Test.....	9
2.8.	History of this test report	10
3.	Antenna Requirements	11
3.1.	Standard Applicable	11
3.2.	Antenna Construction and Directional Gain.....	11
4.	Test of Conducted Emission	12
4.1.	Test Procedures	12
4.2.	Typical Test Setup Layout of Conducted Emission.....	13
4.3.	Conducted Emission Requirement	13
4.4.	Measurement equipment	13
4.5.	Test Result and Data.....	14
4.6.	Photographs of Conducted Emission Test.....	16
5.	Test of Radiated Emission	17
5.1.	Test Procedures	17
5.2.	Typical Test Setup Layout of Radiated Emission.....	18
5.3.	Measurement equipment	18
5.4.	Test Result of Radiated Emission	19
5.5.	Photographs of Radiated Emission Test.....	39
6.	Peak Transmit Power.....	41
6.1.	Test Procedure	41
6.2.	Test Setup Layout	41
6.3.	Measurement equipment	41
6.4.	Test Result and Data.....	41
7.	Peak Power Excursion.....	46
7.1.	Test Procedure	46
7.2.	Test Setup Layout	46
7.3.	Measurement equipment	46
7.4.	Test Result and Data.....	46
8.	Peak Power Spectral Density.....	49
8.1.	Test Procedure	49
8.2.	Test Setup Layout	49
8.3.	Measurement equipment	49
8.4.	Test Result and Data.....	49
9.	Frequency Stability.....	52
9.1.	Test Procedure	52
9.2.	Test Setup Layout	52
9.3.	Measurement equipment	52

9.4. Test Result and Data..... 53

10. Band Edges Measurement 54

 10.1. Test Procedure 54

 10.2. Measurement equipment 54

 10.3. Test Result and Data 54

 10.4. Restrict Band Emission Measurement Data 56

11. Restricted Bands of Operation..... 57

 11.1. Labeling Requirement..... 57

12. RF Exposure 58

 12.1. Limit for Maximum Permissible Exposure (MPE) 58

 12.2. MPE Calculations..... 59

 12.3. FCC Radiation Exposure Statement 59

Appendix A. Photographs of EUT.....A1 ~ A7

CERTIFICATE OF COMPLIANCE

according to

FCC Rules and Regulations

Part 15 Subpart E

Applicant	:	SerComm Corporation
Address	:	8F, No. 3-1, YuanQu St., NanKang, Taipei 115 Taiwan, R.O.C.
Equipment	:	802.11a+g Wireless Access Point
Model No.	:	AP51DA
FCC ID	:	P27AP51DAR

I HEREBY CERTIFY THAT :

The measurements shown in this test report were made in accordance with the procedures given in **ANSI C63.4** The equipment was **passed** the test performed according to **FCC Rules and Regulations Part 15 Subpart E (2003)**.

The test was carried out on Nov. 08, 2007 at **Exclusive Certification Corp.**

Signature

Anson Chou / Manager

1. Report of Measurements and Examinations

1.1. List of Measurements and Examinations

For Frequency 5.15GHz ~ 5.25GHZ

Applied Standard : FCC Part 15, Subpart E (Section 15.407)		
FCC Rule	Description of Test	Result
15.407(b)(5)	. Conducted Emission	Pass
15.407(b/1/2/3)(b)(5)	. Radiated Emission	Pass
15.407(a/1/2/3)	. Peak Transmit Power	Pass
15.407(a)(6)	. Peak Power Excursion	Pass
15.407(a/1/2/3)	. Peak Power Spectral Density	Pass
15.407(g)	. Frequency Stability	Pass

2. Test Configuration of Equipment under Test

2.1. Feature of Equipment under Test

CPU	AR5312
Radio-on-Chip	AR2112+AR5112
DRAM	16 Mbytes
Flash ROM	4 Mbytes
LAN port	1 x Auto-MDIX RJ45 for 10/100Mbps PoE port IEEE 802.3af compliance
Operating temperature	0 ~ 45°C
Storage temperature	-20°C ~ 70°C
Power Adapter	DC 12V/1000mA
Dimensions	189mm(W) x 125mm(D) x 34mm(H)

2.2. RF Specifications

802.11a Data Rates	6, 9, 12, 18, 24, 36, 48, 54 Mbps
802.11a Operating Frequencies	FCC: 5.15 ~ 5.25 GHz, 5.725 ~ 5.825 GHz CE: 5.15 ~ 5.35 GHz, 5.47 ~ 5.725 GHz, 5.725 ~ 5.825 GHz
802.11a Encryption	40-bit (also called 64-bit), 128- and 152-bit WEP data encryption
802.11g Data Rates	1, 2, 5.5, 11, 12, 18, 24, 36, 38, 54 Mbps
802.11g Operating Frequencies	2.412 ~ 2.462 GHz (US) 2.457 ~ 2.462 GHz (Spain) 2.412 ~ 2.484 GHz (Japan) 2.457 ~ 2.472 GHz (France) 2.412 ~ 2.472 GHz (Europe ETSI)
802.11g Encryption	40-bit (also called 64-bit), 128- and 152-bits WEP data encryption
Network Management	Web-based configuration and status monitoring
Maximum Clients	Limited by the amount of wireless network traffic generated by each node; Typically 15 to 20 nodes.
Status LEDs	Power/Ethernet LAN/Wireless LAN/Test
Power Adapter	12V DC, 1 A

2.3. Carrier Frequency of Channels

802.11b/g

Channel	Frequency(MHz)	Channel	Frequency(MHz)
01	2412	08	2447
02	2417	09	2452
03	2422	10	2457
04	2427	11	2462
05	2432	12	2467
06	2437	13	2472
07	2442	---	---

802.11a (5150 ~ 5250MHz, 5725 ~ 5825MHz)

Channel	Frequency(MHz)	Channel	Frequency(MHz)
36	5180	149	5745
40	5200	153	5765
44	5220	157	5785
48	5240	161	5805
---	---	165	5825

2.4. Test Mode and Test Software

The following test mode and test software was performed for conduction and radiation test:

- 802.11a (CH 36: 5180MHz)
- 802.11a (CH 44: 5220MHz)
- 802.11a (CH 48: 5240MHz)
- An executive programs, "ART.exe" Application under WIN XP

The test mode of Radiated emission as below:

- Test Mode 1: Adapter: DSA-15P-12 US 120120
- Test Mode 2: PoE mode

Notes: The device will automatically discontinue transmission, when the transmitting or operating stop.

2.5. Description of Test System

Device	Manufacturer	Model No.	Description
PC	IBM	IGV	Power Cable, Unshielding 1.8 m
Monitor	SlimAGE	510A	Power Cable, Adapter Unshielding 1.8 m Data Cable, VGA shielding 1.35 m
Keyboard	IBM	KB-0225	Data Cable, PS2 shielding 1.85 m
Mouse	IBM	MO28VO	Data Cable, USB shielding 1.85 m
Modem	ACEXX	DM-1414	Power Cable, Adapter Unshielding 1.8 m Data Cable, RS232 shielding 1.35 m
Printer	HP	Desk Jet400	Power Cable, Adapter Unshielding 1.8 m Data Cable, PRINT shielding 1.6 m
POE (Remote site)	Sercomm	FS108P	Power Cable, Adapter Unshielding 1.8 m

Use Cable:

Cable	Description
RJ 45*1	Unshielding, 1.5m
RJ 45*1	Unshielding, 5m

2.6. Connection Diagram of Test System

Test mode 1:

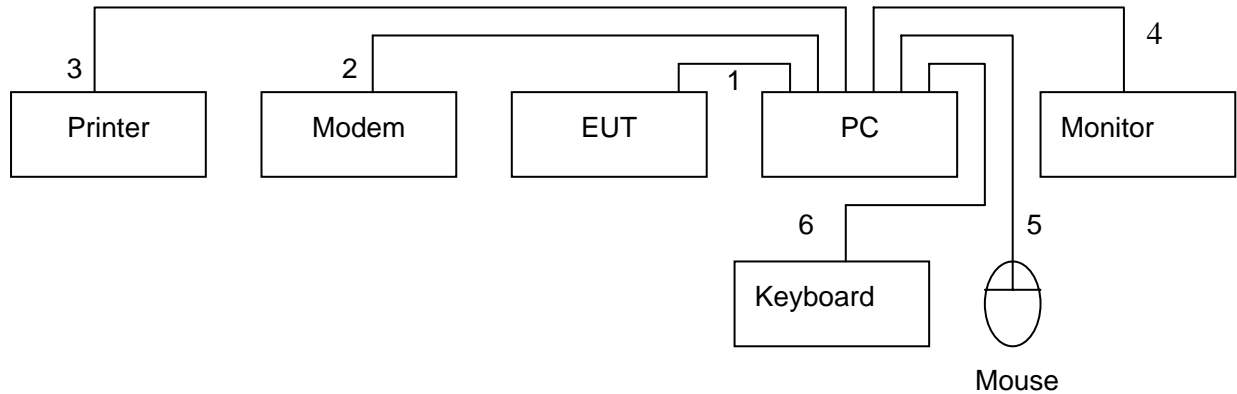

1. The RJ 45 cable is connected from PC to the EUT.
2. The I/O cable is connected from PC to the Modem.
3. The I/O cable is connected from PC to the Printer.
4. The I/O cable is connected from PC to the Monitor.
5. The I/O cable is connected from PC to the Mouse.
6. The I/O cable is connected from PC to the Keyboard.

Test model 2:

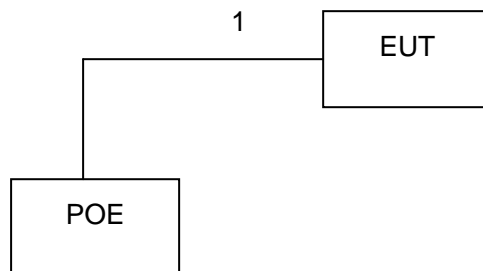

1. The RJ 45 cable is connected from PoE to the EUT.

2.7. General Information of Test

Test Site:	Exclusive Certification Corp. 4F-2, No. 28, Lane 78, Xing-Ai Rd. Nei-hu, Taipei City 114 Taiwan R.O.C.
Test Site Location (OATS1-SD):	No.68-1, Shihbachongsi, shihding Township, Taipei City 223, Taiwan, R.O.C.
FCC Registration Number :	632249
IC Registration Number :	6597A-1
VCCI Registration Number :	T-182 for Telecommunication Test C-2188 for Conducted emission test R-1902 for Radiated emission test
Test Voltage:	AC 120V/ 60Hz
Test in Compliance with:	ANSI C63.4-2003 FCC Part 15 Subpart E
Frequency Range Investigated:	AC Power Conducted Emission : from 150kHz to 30 MHz Radiated and conducted Emission: from 30 MHz to 40 GHz
Test Distance:	The test distance of radiated emission from antenna to EUT is 3 M.

3. Antenna Requirements

3.1. Standard Applicable

For intentional device, according to FCC 47 CFR Section 15.203, an intentional radiator shall be designed to ensure that no antenna other than that furnished by the responsible party shall be used with the device.

And according to FCC 47 CFR Section 15.247 (b), if transmitting antennas of directional gain greater than 6dBi are used, the power shall be reduced by the amount in dB that the directional gain of the antenna exceeds 6dBi.

3.2. Antenna Construction and Directional Gain

Antenna type: Reverse SMA connect, Dipole antenna

Antenna Gain: 5 dBi

4. Test of Conducted Emission

Conducted Emissions were measured from 150 kHz to 30 MHz with a bandwidth of 9 KHz on the 120 VAC power and return leads of the EUT according to the methods defined in ANSI C63.4-2003 Section 3.1. The EUT was placed on a nonmetallic stand in a shielded room 0.8 meters above the ground plane as shown in section 1.3.1. The interface cables and equipment positioning were varied within limits of reasonable applications to determine the position produced maximum conducted emissions.

4.1. Test Procedures

- a. The EUT was placed 0.4 meter from the conducting wall of the shielding room was kept at least 80 centimeters from any other grounded conducting surface.
- b. Connect EUT to the power mains through a line impedance stabilization network (LISN).
- c. All the support units are connecting to the other LISN.
- d. The LISN provides 50 ohm coupling impedance for the measuring instrument.
- e. The FCC states that a 50 ohm, 50 micro-Henry LISN should be used.
- f. Both sides of AC line were checked for maximum conducted interference.
- g. The frequency range from 150 kHz to 30 MHz was searched.
- h. Set the test-receiver system to Peak Detect Function and Specified Bandwidth with Maximum Hold Mode.

4.2. Typical Test Setup Layout of Conducted Emission

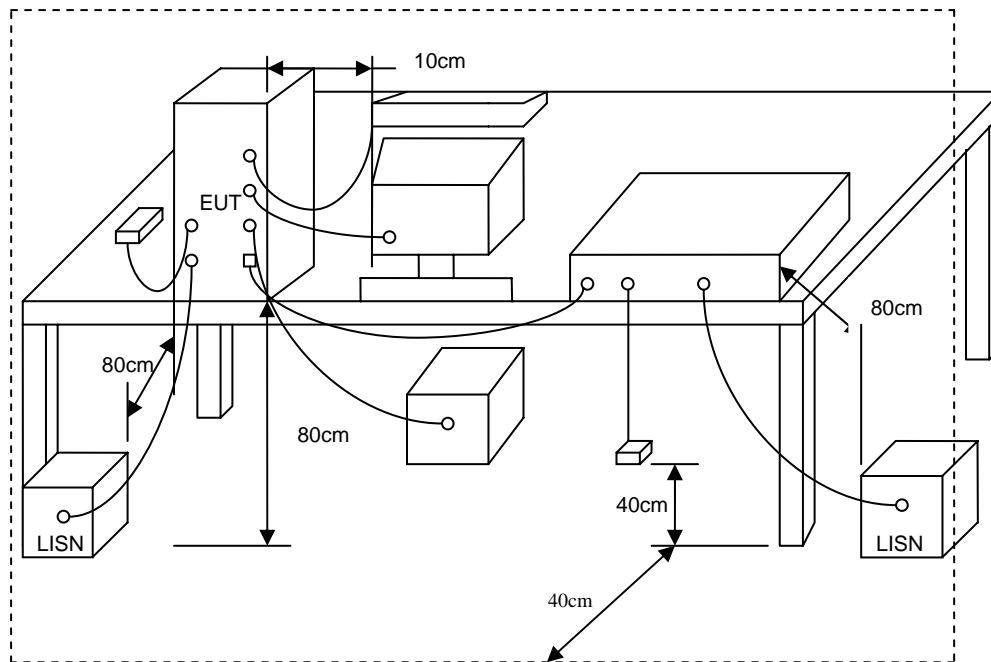

4.3. Conducted Emission Requirement

Except for A digital devices, for equipment that is designed to be connected to the public utility (AC) power line on any frequency voltage that is conducted back onto the AC power line on ant frequency or frequencies within the band 150KHz to 30MHz shall not exceed the limits in the following table, as measured using a 50μH/50 ohms line impedance stabilization network (LISN). Compliance with the provisions of this paragraph shall be based on the measurement of the Radio frequency voltage between each power line and ground at the power terminal. The lower limit applies at the band edges.

Frequency (MHz)	Quasi Peak (dB μ V)	Average (dB μ V)
0.15 – 0.5	66-56*	56-46*
0.5 – 5.0	56	46
5.0 – 30.0	60	50

4.4. Measurement equipment

Instrument/Ancillary	Model No.	Manufacturer	Serial No.	Calibration Date	Valid Date.
Receiver	R&S	ESCI	100443	2006/09/20	2007/09/19
LISN	NNB-2/16Z	MESS TEC	02/10191	2007/05/14	2008/05/13
LISN	NNB-2/16Z	ROLF HEINE	03/10058	2007/04/19	2008/04/18

4.5. Test Result and Data

Power : AC 120V
 Test Mode : 802.11a CH36
 Memo : DSA-15P-12 US 120120

Pol/Phase : NEUTRAL
 Temperature : 26 °C
 Humidity : 55 %

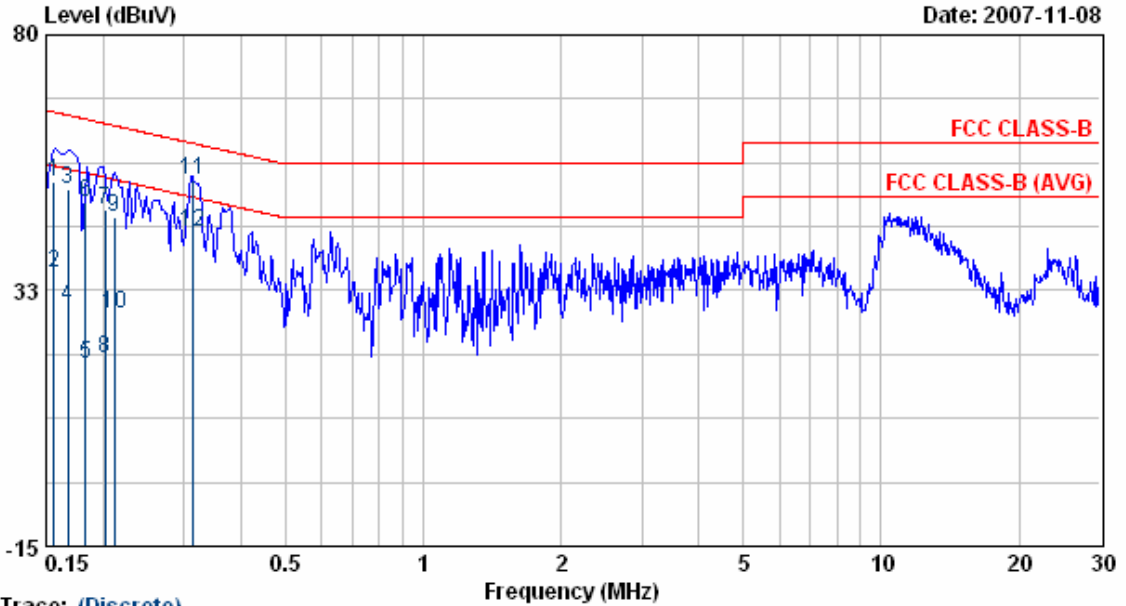

Trace: (Discrete)

Item	Freq	Read Value	Factor	Result	Limit	Margin	Remark
	MHz	dBuV	dB	dBuV	dBuV	dBuV	
1	0.16	52.48	0.09	52.57	65.67	-13.09	QP
2	0.16	35.54	0.09	35.63	55.67	-20.04	AVERAGE
3	0.17	51.37	0.09	51.46	65.08	-13.61	QP
4	0.17	29.60	0.09	29.69	55.08	-25.39	AVERAGE
5	0.18	18.71	0.09	18.80	54.34	-35.54	AVERAGE
6	0.18	48.98	0.09	49.07	64.34	-15.27	QP
7	0.20	47.57	0.09	47.66	63.54	-15.88	QP
8	0.20	19.79	0.09	19.88	53.54	-33.66	AVERAGE
9	0.21	45.93	0.09	46.02	63.17	-17.15	QP
10	0.21	28.21	0.09	28.30	53.17	-24.87	AVERAGE
11	0.31	52.78	0.10	52.89	59.87	-6.99	QP
12	0.31	43.23	0.10	43.33	49.87	-6.54	AVERAGE

- Remarks:
- Level = Read Level + Factor
 - Factor = LISN(ISN) Factor + Cable Loss
 - According to technical experiences, all spurious emission of 802.11a mode at channel 36,44,48 are almost the same below 1GHz, so that the channel 36 was chosen as representative in final test.
 - The data is worse case.

Power : AC 120V
 Test Mode : 802.11a CH36
 Memo : DSA-15P-12 VS 120120

Pol/Phase : LINE
 Temperature : 26 °C
 Humidity : 55 %

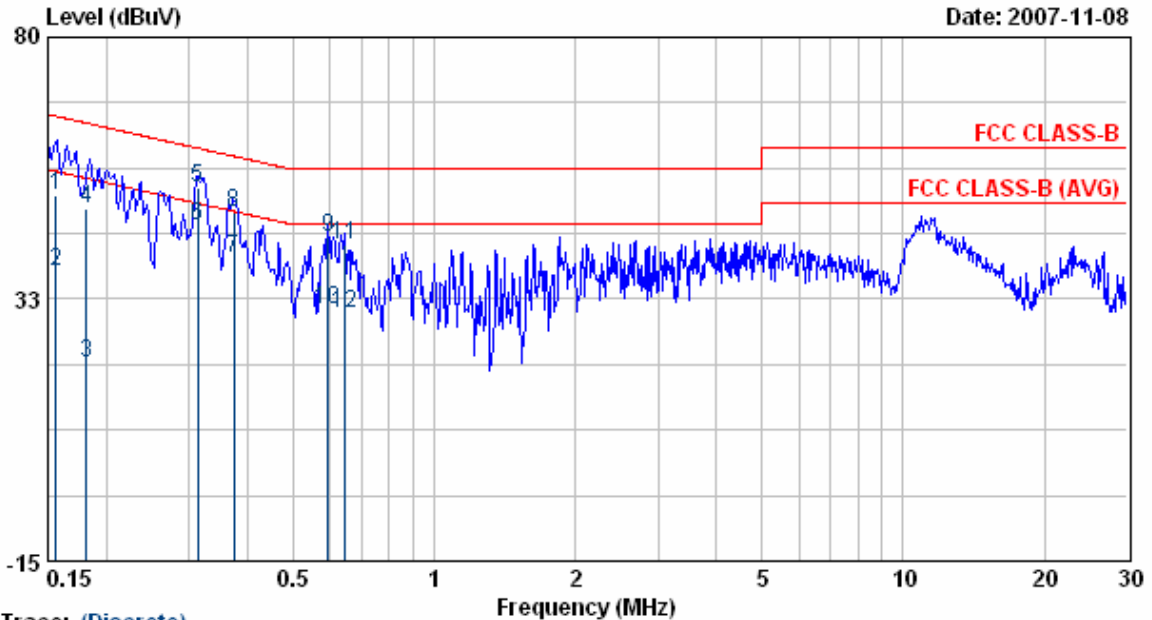

Trace: (Discrete)

Item	Freq	Read Value	Factor	Result	Limit	Margin	Remark
	MHz	dBuV	dB	dBuV	dBuV	dBuV	
1	0.16	51.29	0.10	51.39	65.65	-14.26	QP
2	0.16	37.48	0.10	37.58	55.65	-18.07	AVERAGE
3	0.18	20.93	0.10	21.03	54.44	-33.41	AVERAGE
4	0.18	48.89	0.10	48.99	64.44	-15.45	QP
5	0.31	52.65	0.12	52.77	59.87	-7.10	QP
6	0.31	45.70	0.12	45.82	49.87	-4.05	AVERAGE
7	0.37	39.77	0.12	39.89	48.42	-8.53	AVERAGE
8	0.37	48.10	0.12	48.22	58.42	-10.20	QP
9	0.59	43.75	0.13	43.88	56.00	-12.12	QP
10	0.59	30.41	0.13	30.54	46.00	-15.46	AVERAGE
11	0.65	42.18	0.14	42.32	56.00	-13.68	QP
12	0.65	29.78	0.14	29.91	46.00	-16.09	AVERAGE

Remarks: 1. Level = Read Level + Factor
 2. Factor = LISN(ISN) Factor + Cable Loss
 3. According to technical experiences, all spurious emission of 802.11a mode at channel 36, 44, 48 are almost the same below 1GHz, so that the channel 36 was chosen as representative in final test.
 4. The data is worse case.

Test engineer: Ben

5. Test of Radiated Emission

Radiated emissions from 30 MHz to 40 GHz were measured according to the methods defines in ANSI C63.4-2003. The EUT was placed, 0.8 meter above the ground plane, as shown in section 1.4.2. The interface cables and equipment positions were varied within limits of reasonable applications to determine the positions producing maximum radiated emissions

5.1. Test Procedures

1. The EUT was placed on a rotatable table top 0.8 meter above ground.
2. The EUT was set 3 meters from the interference receiving antenna which was mounted on the top of a variable height antenna tower.
3. The table was rotated 360 degrees to determine the position of the highest radiation.
4. The antenna is a broadband antenna and its height is varied between one meter and four meters above ground to find the maximum value of the field strength both horizontal polarization and vertical polarization of the antenna are set to make the measurement.
5. For each suspected emission the EUT was arranged to its worst case and then tune the antenna tower (from 1 M to 4 M) and turn table (from 0 degree to 360 degrees) to find the maximum reading.
6. Set the test-receiver system to Peak or CISPR quasi-peak Detect Function and specified bandwidth with Maximum Hold Mode.
7. If the emission level of the EUT in peak mode was 3 dB lower than the limit specified, then testing will be stopped and peak values of EUT will be reported, otherwise, the emissions which do not have 3 dB margin will be repeated one by one using the quasi-peak method and reported.
8. For testing above 1GHz, the emission level of the EUT in peak mode was 20dB lower than average limit (that means the emission level in peak mode also complies with the limit in average mode), then testing will be stopped and peak values of EUT will be reported, otherwise, the emissions will be measured in average mode again and reported.

5.2. Typical Test Setup Layout of Radiated Emission

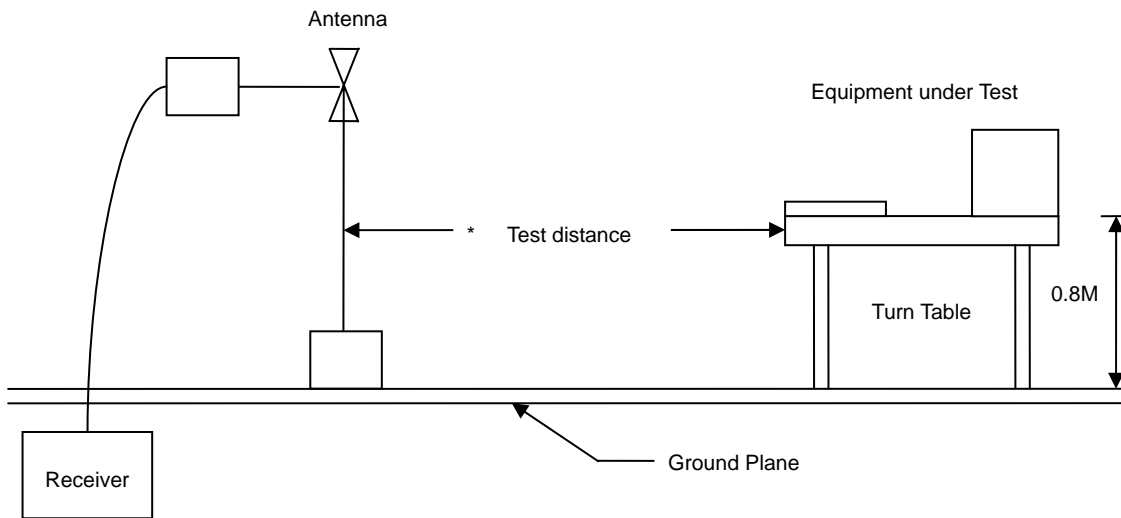

5.3. Measurement equipment

Instrument/Ancillary	Model No.	Manufacturer	Serial No.	Calibration Date	Valid Date
EMI Receiver	85460A	HP	3807A00454	2007/06/05	2008/06/04
Spectrum Analyzer	FSP40	R&S	10047	2007/01/23	2008/01/22
Horn Antenna	3115	EMCO	31589	2007/03/05	2008/03/04
Horn Antenna	3116	EMCO	31970	2007/03/06	2008/03/05
Bilog Antenna	CBL6112B	Schaffner	2840	2007/04/26	2008/04/25
Amplifier	8449B	Agilent	3008A01954	2007/01/12	2008/01/11
Amplifier	8447D	Agilent	2944A10531	2006/09/11	2007/09/10
Amplifier	PA-840	Com-Power	711885	2007/08/28	2008/08/27

5.4. Test Result of Radiated Emission

Test Mode 1:

Power	: AC 120V	Pol/Phase	: VERTICAL
Test Mode	: Transmit/Receive	Temperature	: 22 °C
Operation Channel	: 36	Humidity	: 70 %
Modulation Type	: 802.11a	Atmospheric Pressure	: 1010 hPa
Rate	: 54 Mbps		
Memo	: DSA-15P-12 US 120120		

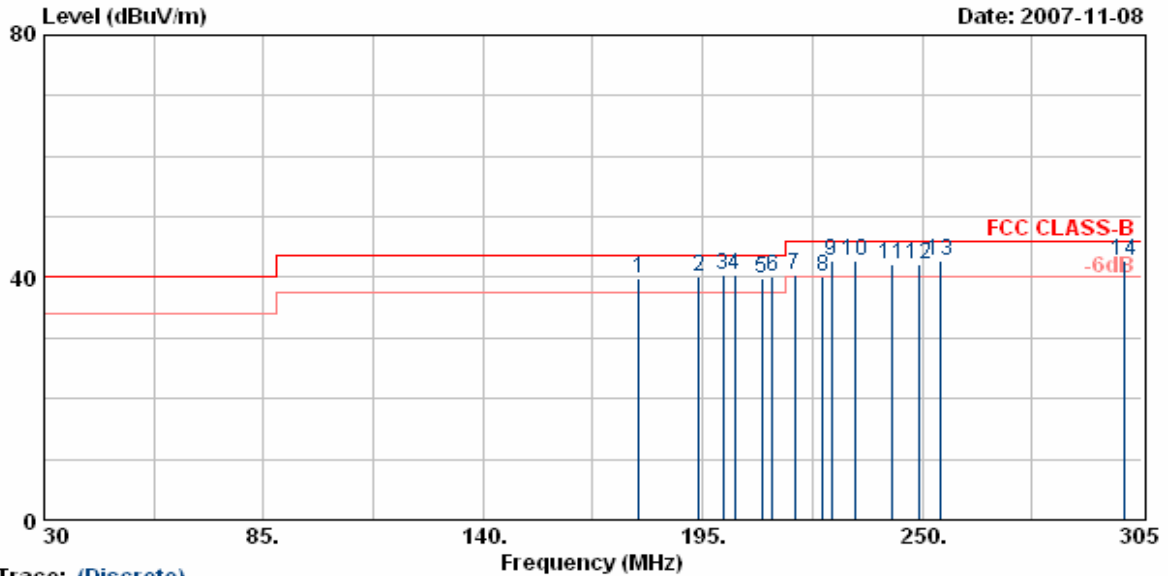

Trace: (Discrete)

Item	Freq	Read Value	Factor	Result	Limit	Margin	Remark	Ant Pos	Tab Pos
	MHz	dBuV/m	dB	dBuV/m	dBuV/m	dB		cm	Deg
1	179.05	46.35	-6.36	39.99	43.50	-3.51	QP	100	360
2	194.18	47.25	-7.13	40.12	43.50	-3.38	QP	100	360
3	200.23	48.20	-7.80	40.40	43.50	-3.10	QP	100	360
4	202.98	48.36	-8.01	40.35	43.50	-3.15	QP	100	360
5	209.85	47.84	-7.86	39.98	43.50	-3.52	QP	100	360
6	212.60	47.31	-7.20	40.11	43.50	-3.39	QP	100	360
7	218.10	46.80	-6.40	40.40	46.00	-5.60	QP	100	360
8	224.98	45.59	-5.45	40.14	46.00	-5.86	QP	100	360
9	227.18	48.47	-5.60	42.87	46.00	-3.13	QP	100	360
10	233.23	48.71	-5.82	42.89	46.00	-3.11	QP	100	360
11	242.30	46.66	-4.52	42.14	46.00	-3.86	QP	100	360
12	249.18	47.30	-5.00	42.30	46.00	-3.70	QP	100	360
13	254.68	48.92	-6.07	42.85	46.00	-3.15	QP	100	360
14	300.60	48.00	-5.14	42.86	46.00	-3.14	QP	100	360

Notes:

1. Result = Read Value + Factor
2. Factor = Antenna Factor + Cable Loss - Amplifier
3. The resolution bandwidth of test receiver/spectrum analyzer is 120KHz and video bandwidth is 300kHz for Peak detection and Quasi-peak detection at frequency below 1GHz.
4. According to technical experiences, all spurious emission of 802.11a mode at channel 36,44,48 are almost the same below 1GHz, so that the channel 36 was chosen as representative in final test.
5. The data is worse case.

Power : AC 120V
 Test Mode : Transmit/Receive
 Operation Channel: 36
 Modulation Type : 802.11a
 Rate : 54 Mbps
 Memo : DSA-15P-12 US 120120

Pol/Phase : VERTICAL
 Temperature : 22 °C
 Humidity : 70 %
 Atmospheric Pressure: 1010 hPa

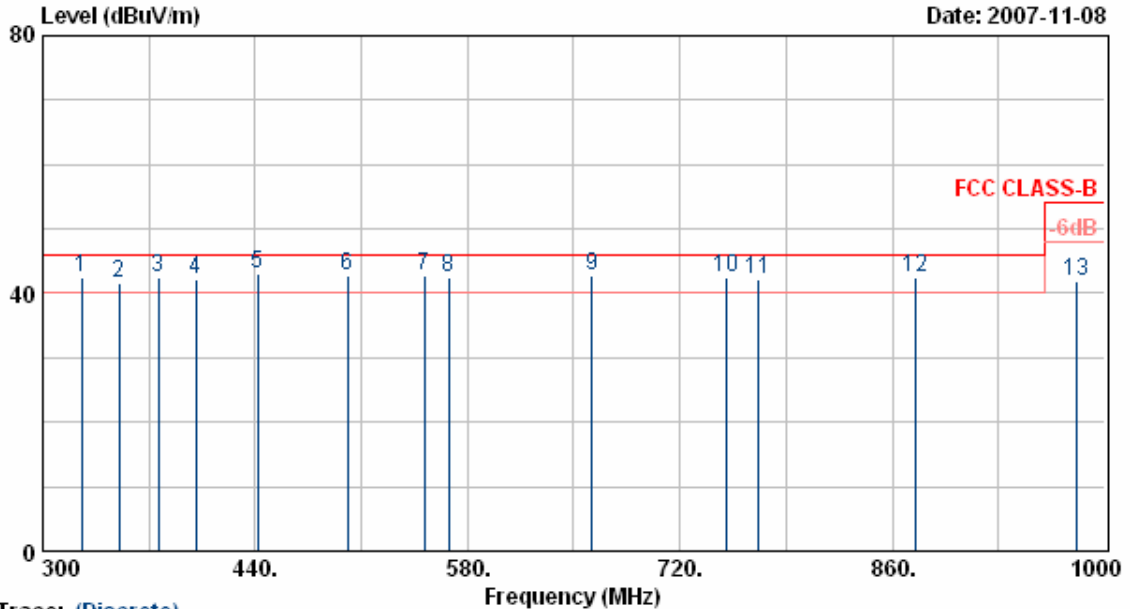

Trace: (Discrete)

Item	Freq MHz	Read Value dBuV/m	Factor dB	Result dBuV/m	Limit dBuV/m	Margin dB	Remark	Ant Pos cm	Tab Pos Deg
1	325.90	50.90	-8.56	42.34	46.00	-3.66	QP	100	0
2	350.40	47.90	-6.23	41.67	46.00	-4.33	QP	100	0
3	376.30	46.08	-3.71	42.37	46.00	-3.63	QP	100	0
4	400.80	46.37	-4.06	42.31	46.00	-3.69	QP	100	0
5	441.40	46.44	-3.48	42.96	46.00	-3.04	QP	100	0
6	500.90	45.40	-2.69	42.71	46.00	-3.29	QP	100	0
7	551.30	39.94	2.72	42.66	46.00	-3.34	QP	100	0
8	567.40	39.80	2.63	42.43	46.00	-3.57	QP	100	0
9	661.90	42.60	0.20	42.80	46.00	-3.20	QP	100	0
10	750.80	36.64	5.70	42.34	46.00	-3.66	QP	100	0
11	771.80	36.48	5.60	42.08	46.00	-3.92	QP	100	0
12	875.40	37.33	5.20	42.53	46.00	-3.47	QP	100	0
13	981.80	32.19	9.84	42.03	54.00	-11.97	Peak	100	0

Notes:

1. Result = Read Value + Factor
2. Factor = Antenna Factor + Cable Loss - Amplifier
3. The resolution bandwidth of test receiver/spectrum analyzer is 120KHz and video bandwidth is 300KHz for Peak detection and Quasi-peak detection at frequency below 1GHz.
4. According to technical experiences, all spurious emission of 802.11a mode at channel 36,44,48 are almost the same below 1GHz, so that the channel 36 was chosen as representative in final test.
5. The data is worse case.

Power	: AC 120V	Pol/Phase	: HORIZONTAL
Test Mode	: Transmit/Receive	Temperature	: 22 °C
Operation Channel	: 36	Humidity	: 70 %
Modulation Type	: 802.11a	Atmospheric Pressure	: 1010 hPa
Rate	: 54 Mbps		
Memo	: DSA-15P-12 US 120120		

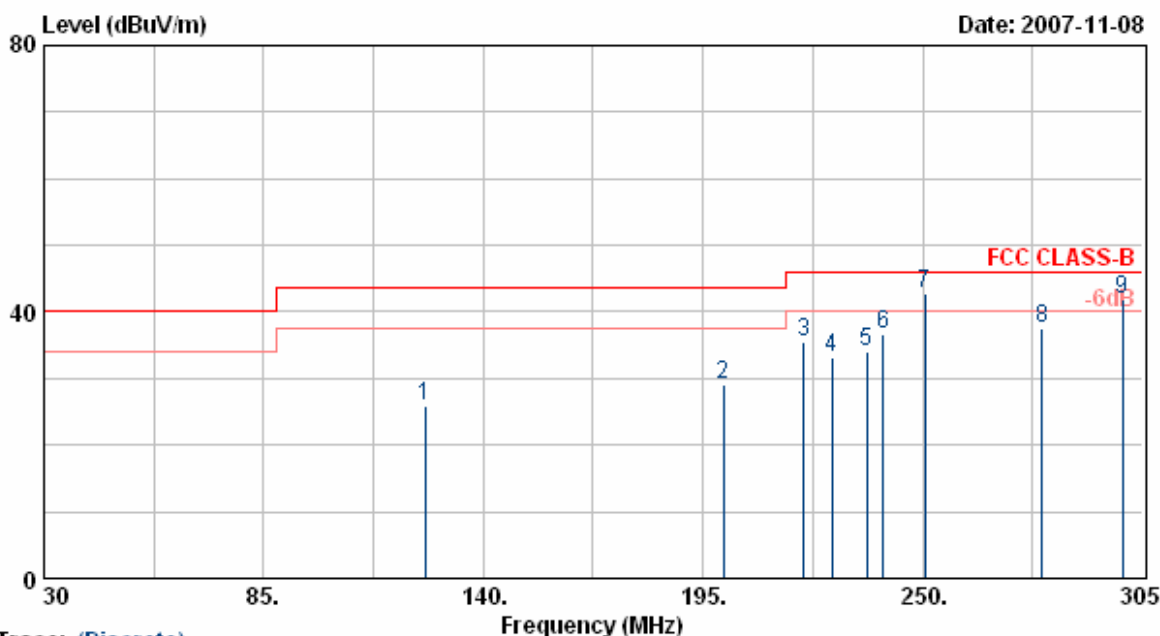

Trace: (Discrete)

Item	Freq	Read Value	Factor	Result	Limit	Margin	Remark	Ant Pos	Tab Pos
	MHz	dBuV/m	dB	dBuV/m	dBuV/m	dB		cm	Deg
1	125.43	40.77	-14.97	25.80	43.50	-17.70	Peak	100	360
2	200.23	40.26	-11.23	29.03	43.50	-14.47	Peak	100	360
3	220.30	45.53	-10.16	35.37	46.00	-10.63	Peak	100	360
4	227.18	43.27	-10.13	33.14	46.00	-12.86	Peak	100	360
5	235.98	43.72	-9.62	34.10	46.00	-11.90	Peak	100	360
6	240.10	46.75	-10.09	36.66	46.00	-9.34	Peak	100	360
7	250.55	52.44	-9.72	42.72	46.00	-3.28	QP	100	360
8	279.98	44.36	-6.77	37.59	46.00	-8.41	Peak	100	360
9	300.05	46.81	-5.06	41.75	46.00	-4.25	QP	100	360

Notes:

1. Result = Read Value + Factor
2. Factor = Antenna Factor + Cable Loss - Amplifier
3. The resolution bandwidth of test receiver/spectrum analyzer is 120KHz and video bandwidth is 300kHz for Peak detection and Quasi-peak detection at frequency below 1GHz.
4. According to technical experiences, all spurious emission of 802.11a mode at channel 36, 44, 48 are almost the same below 1GHz, so that the channel 36 was chosen as representative in final test.
5. The data is worse case.

Power : AC 120V Pol/Phase : HORIZONTAL
 Test Mode : Transmit/Receive Temperature : 22 °C
 Operation Channel: 36 Humidity : 70 %
 Modulation Type : 802.11a Atmospheric Pressure: 1010 hPa
 Rate : 54 Mbps
 Memo : DSA-15P-12 US 120120

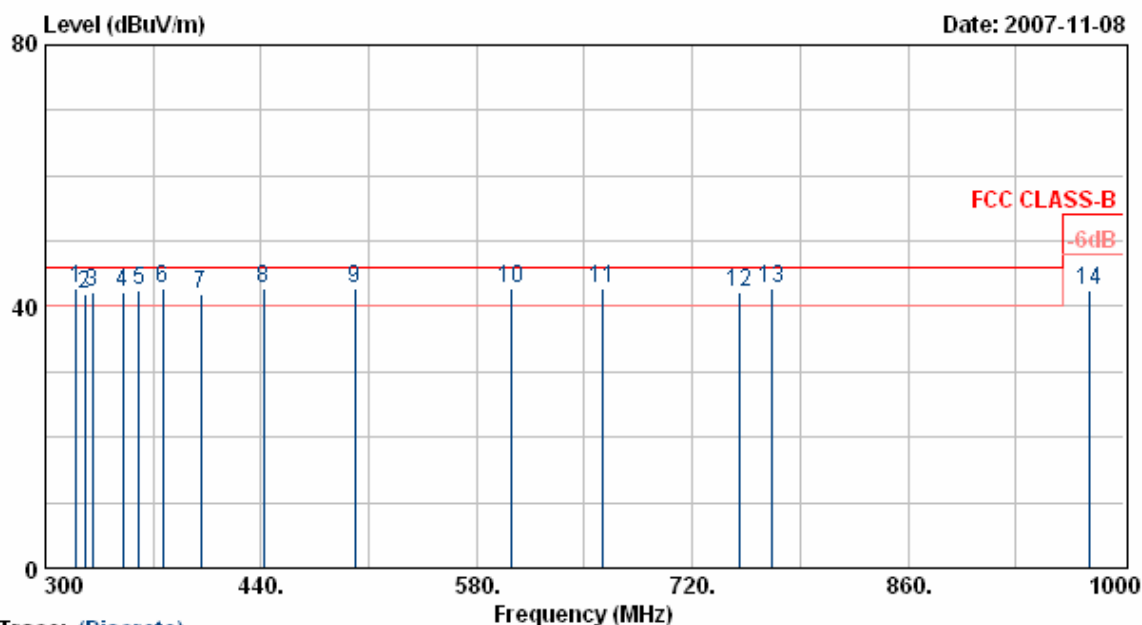

Trace: (Discrete)

Item	Freq	Read Value	Factor	Result	Limit	Margin	Remark	Ant Pos	Tab Pos
	MHz	dBuV/m	dB	dBuV/m	dBuV/m	dB		cm	Deg
1	320.30	46.52	-3.64	42.88	46.00	-3.12	QP	100	0
2	325.90	46.92	-5.03	41.89	46.00	-4.11	QP	100	0
3	330.80	48.20	-5.96	42.24	46.00	-3.76	QP	100	0
4	350.40	47.57	-5.50	42.07	46.00	-3.93	QP	100	0
5	360.90	46.77	-4.29	42.48	46.00	-3.52	QP	100	0
6	376.30	45.48	-2.58	42.90	46.00	-3.10	QP	100	0
7	400.80	44.15	-2.13	42.02	46.00	-3.98	QP	100	0
8	441.40	44.57	-1.69	42.88	46.00	-3.12	QP	100	0
9	500.90	45.93	-3.24	42.69	46.00	-3.31	QP	100	0
10	602.40	40.40	2.25	42.65	46.00	-3.35	QP	100	0
11	661.90	39.80	2.94	42.74	46.00	-3.26	QP	100	0
12	750.80	36.74	5.43	42.17	46.00	-3.83	QP	100	0
13	771.80	36.31	6.44	42.75	46.00	-3.25	QP	100	0
14	978.30	34.86	7.71	42.57	54.00	-11.43	Peak	100	0

Notes:

1. Result = Read Value + Factor
2. Factor = Antenna Factor + Cable Loss - Amplifier
3. The resolution bandwidth of test receiver/spectrum analyzer is 120KHz and video bandwidth is 300kHz for Peak detection and Quasi-peak detection at frequency below 1GHz.
4. According to technical experiences, all spurious emission of 802.11a mode at channel 36,44,48 are almost the same below 1GHz, so that the channel 36 was chosen as representative in final test.
5. The data is worse case.

Power	: AC 120V	Pol/Phase	: VERTICAL
Test Mode	: Transmit/Receive	Temperature	: 22 °C
Operation Channel	: 36	Humidity	: 70 %
Modulation Type	: 802.11a	Atmospheric Pressure	: 1010 hPa
Rate	: 54 Mbps		
Memo	: DSA-15P-12 US 120120		

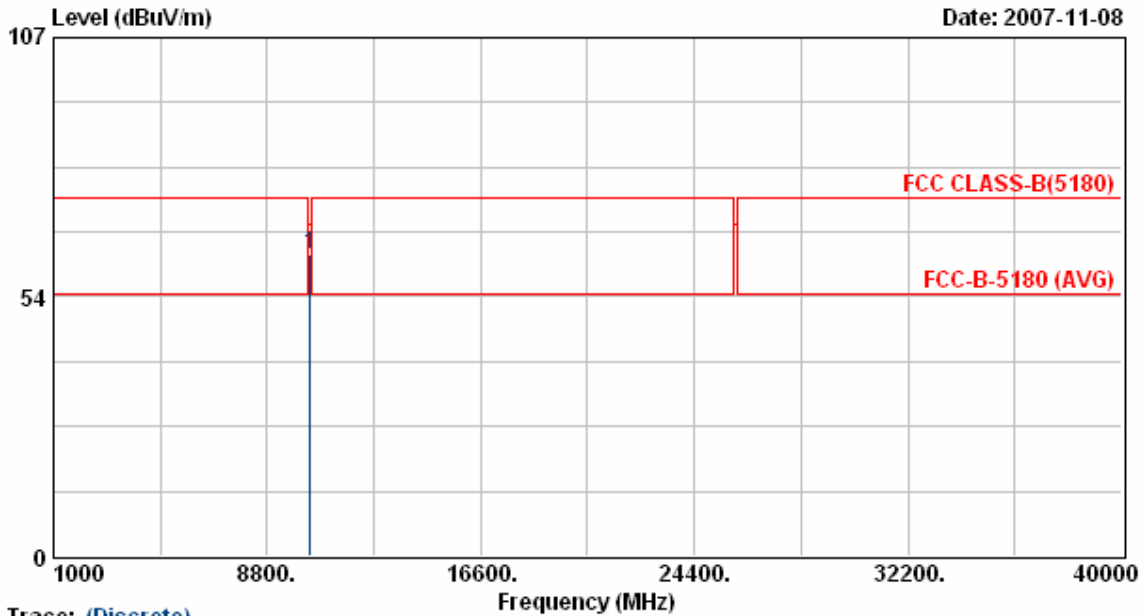

Trace: (Discrete)

Item	Freq	Read Value	Factor	Result	Limit	Margin	Remark	Ant Pos	Tab Pos
	MHz	dBuV/m	dB	dBuV/m	dBuV/m	dB		cm	Deg
1	10360.50	43.50	18.87	62.36	68.30	-5.94	Peak	100	214

Notes:

1. Result = Read Value + Factor
2. Factor = Antenna Factor + Cable Loss - Amplifier
3. The resolution bandwidth of test receiver/spectrum analyzer is 120KHz and video bandwidth is 300kHz for Peak detection and Quasi-peak detection at frequency below 1GHz.
4. The resolution bandwidth of test receiver/spectrum analyzer is 1MHz and video bandwidth is 3MHz for Peak detection at frequency above 1GHz.
5. The resolution bandwidth of test receiver/spectrum analyzer is 1MHz and video bandwidth is 10Hz for Average detection at frequency above 1GHz.
6. The other emissions is too low to be measured.

Power : AC 120V
 Test Mode : Transmit/Receive
 Operation Channel: 36
 Modulation Type : 802.11a
 Rate : 54 Mbps
 Memo : DSA-15P-12 US 120120

Pol/Phase : HORIZONTAL
 Temperature : 22 °C
 Humidity : 70 %
 Atmospheric Pressure: 1010 hPa

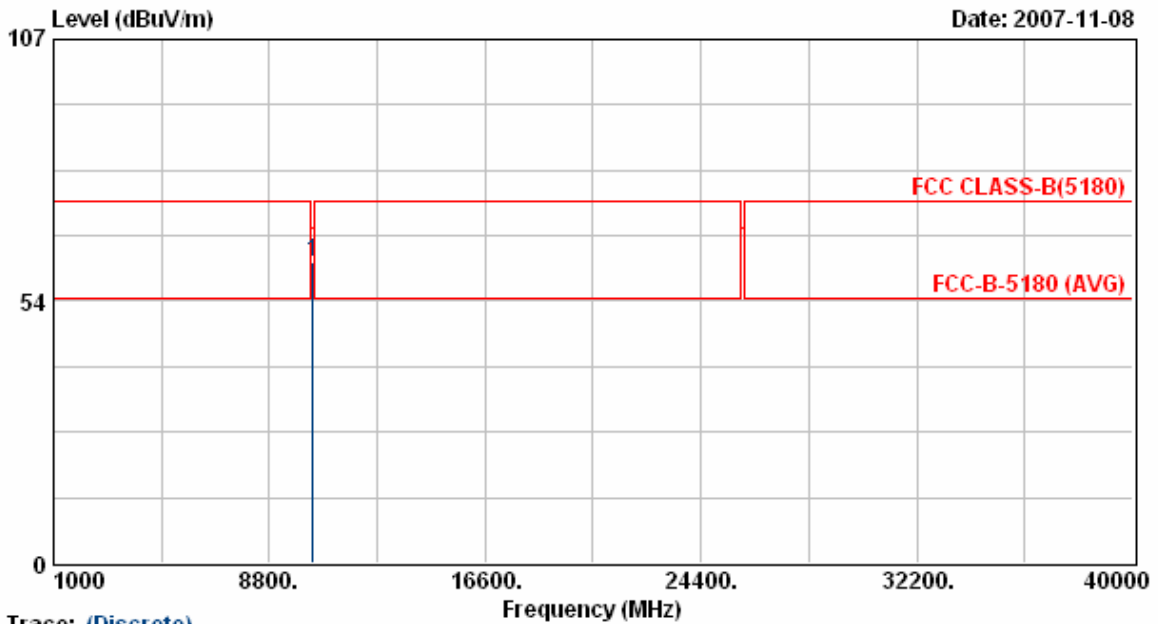

Trace: (Discrete)

Item	Freq	Read Value	Factor	Result	Limit	Margin	Remark	Ant Pos	Tab Pos
	MHz	dBuV/m	dB	dBuV/m	dBuV/m	dB		cm	Deg
1	10360.25	42.55	18.87	61.42	68.30	-6.88	Peak	100	201

Notes:

1. Result = Read Value + Factor
2. Factor = Antenna Factor + Cable Loss - Amplifier
3. The resolution bandwidth of test receiver/spectrum analyzer is 120KHz and video bandwidth is 300kHz for Peak detection and Quasi-peak detection at frequency below 1GHz.
4. The resolution bandwidth of test receiver/spectrum analyzer is 1MHz and video bandwidth is 3MHz for Peak detection at frequency above 1GHz.
5. The resolution bandwidth of test receiver/spectrum analyzer is 1MHz and video bandwidth is 10Hz for Average detection at frequency above 1GHz.
6. The other emissions is too low to be measured.

Power	: AC 120V	Pol/Phase	: VERTICAL
Test Mode	: Transmit/Receive	Temperature	: 22 °C
Operation Channel	: 44	Humidity	: 70 %
Modulation Type	: 802.11a	Atmospheric Pressure	: 1010 hPa
Rate	: 54 Mbps		
Memo	: DSA-15P-12 US 120120		

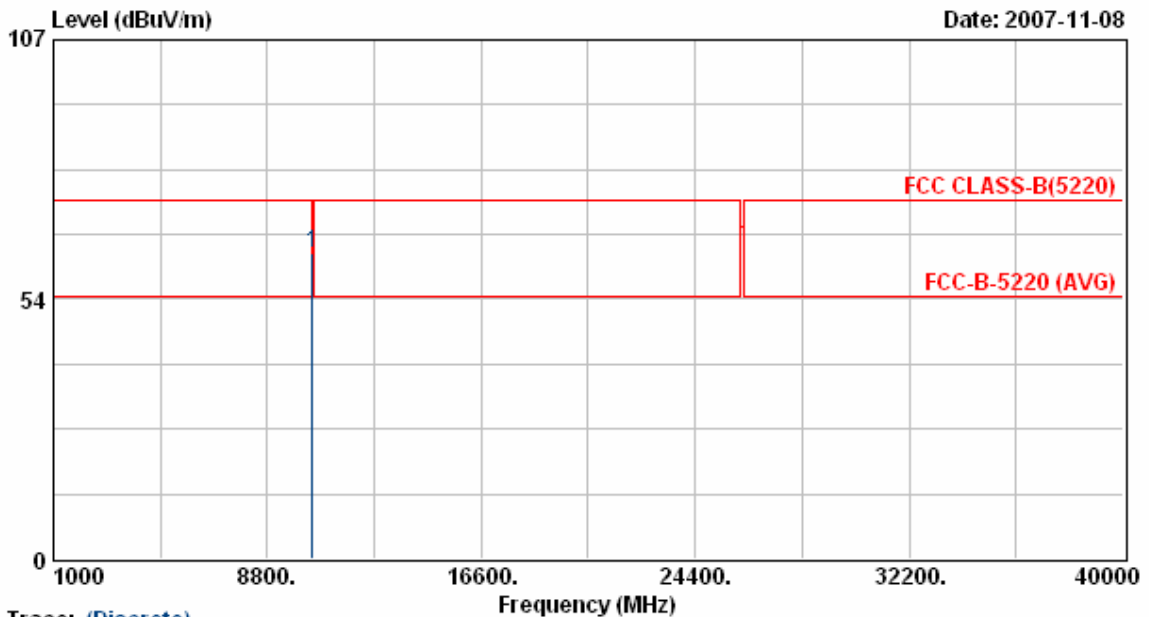

Trace: (Discrete)

Item	Freq	Read Value	Factor	Result	Limit	Margin	Remark	Ant Pos	Tab Pos
	MHz	dBuV/m	dB	dBuV/m	dBuV/m	dB		cm	Deg
1	10440.50	43.95	18.98	62.93	68.30	-5.37	Peak	100	214

Notes:

1. Result = Read Value + Factor
2. Factor = Antenna Factor + Cable Loss - Amplifier
3. The resolution bandwidth of test receiver/spectrum analyzer is 120KHz and video bandwidth is 300kHz for Peak detection and Quasi-peak detection at frequency below 1GHz.
4. The resolution bandwidth of test receiver/spectrum analyzer is 1MHz and video bandwidth is 3MHz for Peak detection at frequency above 1GHz.
5. The resolution bandwidth of test receiver/spectrum analyzer is 1MHz and video bandwidth is 10Hz for Average detection at frequency above 1GHz.
6. The other emissions is too low to be measured.

Power : AC 120V
 Test Mode : Transmit/Receive
 Operation Channel: 44
 Modulation Type : 802.11a
 Rate : 54 Mbps
 Memo : DSA-15P-12 US 120120

Pol/Phase : HORIZONTAL
 Temperature : 22 °C
 Humidity : 70 %
 Atmospheric Pressure: 1010 hPa

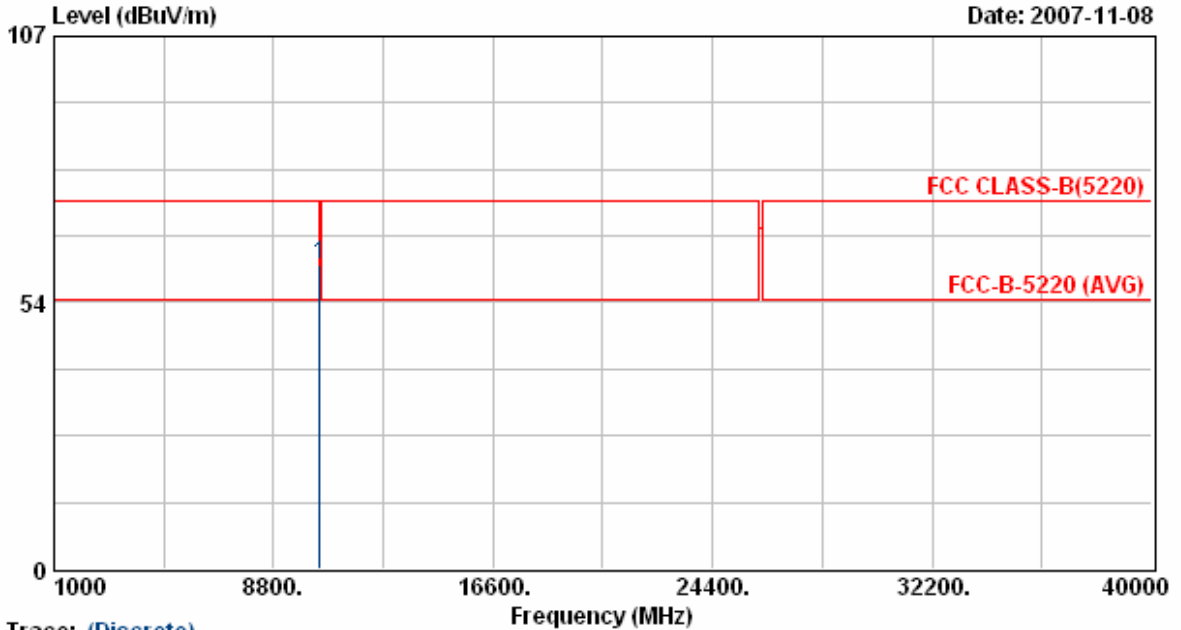

Trace: (Discrete)

Item	Freq	Read Value	Factor	Result	Limit	Margin	Remark	Ant Pos	Tab Pos
	MHz	dBuV/m	dB	dBuV/m	dBuV/m	dB		cm	Deg
1	10440.38	42.25	18.98	61.23	68.30	-7.07	Peak	100	201

Notes:

1. Result = Read Value + Factor
2. Factor = Antenna Factor + Cable Loss - Amplifier
3. The resolution bandwidth of test receiver/spectrum analyzer is 120KHz and video bandwidth is 300kHz for Peak detection and Quasi-peak detection at frequency below 1GHz.
4. The resolution bandwidth of test receiver/spectrum analyzer is 1MHz and video bandwidth is 3MHz for Peak detection at frequency above 1GHz.
5. The resolution bandwidth of test receiver/spectrum analyzer is 1MHz and video bandwidth is 10Hz for Average detection at frequency above 1GHz.
6. The other emissions is too low to be measured.

Power : AC 120V
 Test Mode : Transmit/Receive
 Operation Channel: 48
 Modulation Type : 802.11a
 Rate : 54 Mbps
 Memo : DSA-15P-12 US 120120

Pol/Phase : VERTICAL
 Temperature : 22 °C
 Humidity : 70 %
 Atmospheric Pressure: 1010 hPa

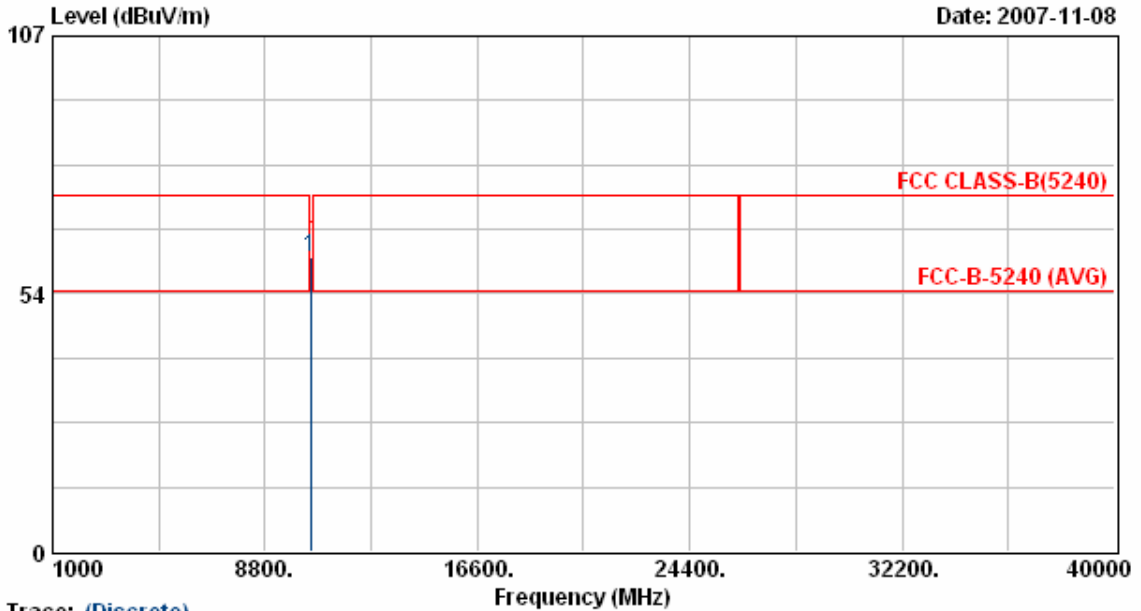

Trace: (Discrete)

Item	Freq	Read Value	Factor	Result	Limit	Margin	Remark	Ant Pos	Tab Pos
	MHz	dBuV/m	dB	dBuV/m	dBuV/m	dB		cm	Deg
1	10480.50	41.98	19.04	61.02	68.30	-7.28	Peak	100	214

Notes:

1. Result = Read Value + Factor
2. Factor = Antenna Factor + Cable Loss - Amplifier
3. The resolution bandwidth of test receiver/spectrum analyzer is 120KHz and video bandwidth is 300kHz for Peak detection and Quasi-peak detection at frequency below 1GHz.
4. The resolution bandwidth of test receiver/spectrum analyzer is 1MHz and video bandwidth is 3MHz for Peak detection at frequency above 1GHz.
5. The resolution bandwidth of test receiver/spectrum analyzer is 1MHz and video bandwidth is 10Hz for Average detection at frequency above 1GHz.
6. The other emissions is too low to be measured.

Power	: AC 120V	Pol/Phase	: HORIZONTAL
Test Mode	: Transmit/Receive	Temperature	: 22 °C
Operation Channel	: 48	Humidity	: 70 %
Modulation Type	: 802.11a	Atmospheric Pressure	: 1010 hPa
Rate	: 54 Mbps		
Memo	: DSA-15P-12 US 120120		

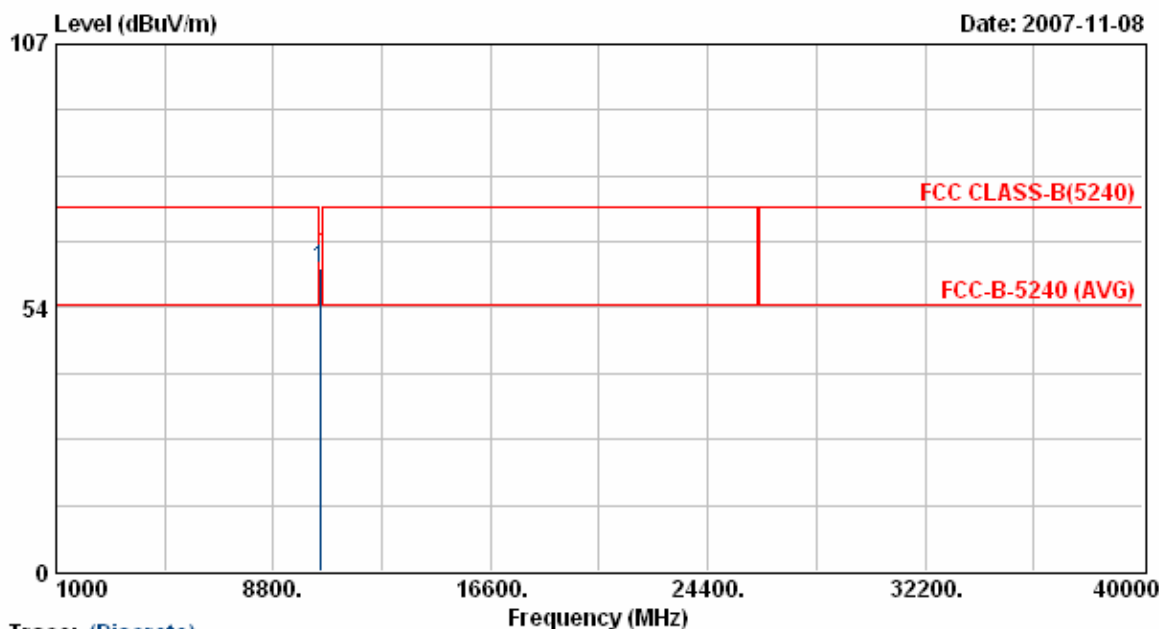

Trace: (Discrete)

Item	Freq	Read Value	Factor	Result	Limit	Margin	Remark	Ant Pos	Tab Pos
	MHz	dBuV/m	dB	dBuV/m	dBuV/m	dB		cm	Deg
1	10480.63	42.40	19.04	61.44	68.30	-6.86	Peak	100	201

Notes:

1. Result = Read Value + Factor
2. Factor = Antenna Factor + Cable Loss - Amplifier
3. The resolution bandwidth of test receiver/spectrum analyzer is 120KHz and video bandwidth is 300kHz for Peak detection and Quasi-peak detection at frequency below 1GHz.
4. The resolution bandwidth of test receiver/spectrum analyzer is 1MHz and video bandwidth is 3MHz for Peak detection at frequency above 1GHz.
5. The resolution bandwidth of test receiver/spectrum analyzer is 1MHz and video bandwidth is 10Hz for Average detection at frequency above 1GHz.
6. The other emissions is too low to be measured.

Test Mode 2:

Power	: DC 48V from POE	Pol/Phase	: VERTICAL
Test Mode	: Transmit/Receive	Temperature	: 22 °C
Operation Channel	: 36	Humidity	: 70 %
Modulation Type	: 802.11a	Atmospheric Pressure	: 1010 hPa
Rate	: 54 Mbps		
Memo	:		

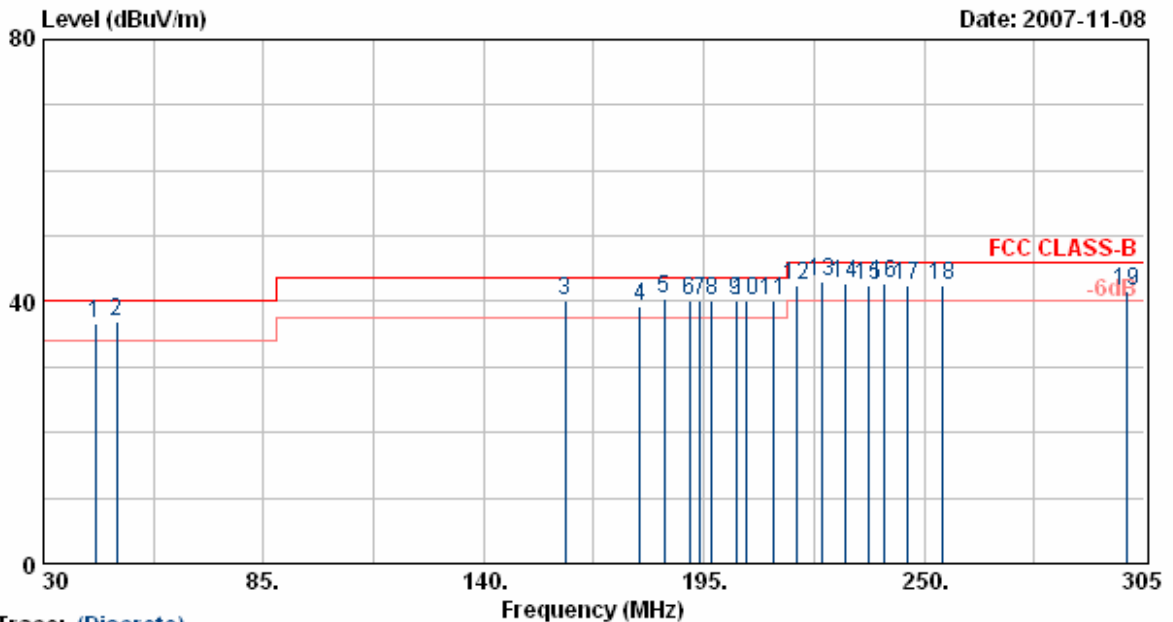

Trace: (Discrete)

Item	Freq MHz	Read Value dBuV/m	Factor dB	Result dBuV/m	Limit dBuV/m	Margin dB	Remark	Ant Pos cm	Tab Pos Deg
1	42.93	40.70	-3.90	36.80	40.00	-3.20	QP	100	0
2	48.43	43.00	-6.10	36.90	40.00	-3.10	QP	100	0
3	160.35	46.99	-6.90	40.09	43.50	-3.41	QP	100	0
4	179.05	45.49	-6.36	39.13	43.50	-4.37	QP	100	0
5	185.10	46.50	-6.17	40.33	43.50	-3.17	QP	100	0
6	191.43	46.74	-6.48	40.26	43.50	-3.24	QP	100	0
7	194.18	47.22	-7.13	40.09	43.50	-3.41	QP	100	0
8	196.93	47.68	-7.52	40.16	43.50	-3.34	QP	100	0
9	202.98	48.24	-8.01	40.23	43.50	-3.27	QP	100	0
10	205.73	48.35	-8.13	40.22	43.50	-3.28	QP	100	0
11	212.60	47.35	-7.20	40.15	43.50	-3.35	QP	100	0
12	218.10	48.81	-6.40	42.41	46.00	-3.59	QP	100	0
13	224.43	48.54	-5.54	43.00	46.00	-3.00	QP	100	0
14	230.48	48.41	-5.74	42.67	46.00	-3.33	QP	100	0
15	235.98	48.17	-5.73	42.44	46.00	-3.56	QP	100	0
16	240.10	47.50	-4.72	42.78	46.00	-3.22	QP	100	0
17	245.60	46.57	-4.23	42.34	46.00	-3.66	QP	100	0
18	254.68	48.54	-6.07	42.47	46.00	-3.53	QP	100	0
19	300.60	46.80	-5.14	41.66	46.00	-4.34	QP	100	0

Notes:

1. Result = Read Value + Factor
2. Factor = Antenna Factor + Cable Loss - Amplifier
3. The resolution bandwidth of test receiver/spectrum analyzer is 120KHz and video bandwidth is 300kHz for Peak detection and Quasi-peak detection at frequency below 1GHz.
4. According to technical experiences, all spurious emission of 802.11a mode at channel 36,44,48 are almost the same below 1GHz, so that the channel 36 was chosen as representative in final test.
5. The data is worse case.

Power	: DC 48V from POE	Pol/Phase	: VERTICAL
Test Mode	: Transmit/Receive	Temperature	: 22 °C
Operation Channel	: 36	Humidity	: 70 %
Modulation Type	: 802.11a	Atmospheric Pressure	: 1010 hPa
Rate	: 54 Mbps		
Memo	:		

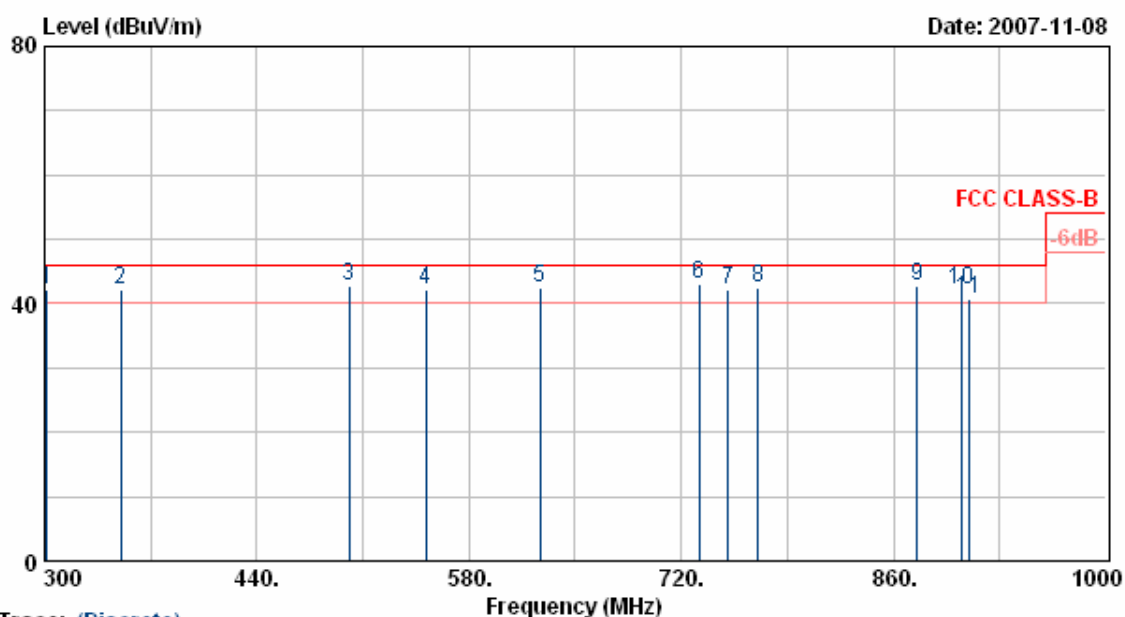

Trace: (Discrete)

Item	Freq	Read Value	Factor	Result	Limit	Margin	Remark	Ant Pos	Tab Pos
	MHz	dBuV/m	dB	dBuV/m	dBuV/m	dB		cm	Deg
1	301.40	47.15	-5.10	42.05	46.00	-3.95	QP	100	360
2	350.40	48.33	-6.23	42.10	46.00	-3.90	QP	100	360
3	500.90	45.50	-2.69	42.81	46.00	-3.19	QP	100	360
4	551.30	39.58	2.72	42.30	46.00	-3.70	QP	100	360
5	626.90	40.98	1.41	42.39	46.00	-3.61	QP	100	360
6	731.90	36.72	6.28	43.00	46.00	-3.00	QP	100	360
7	750.80	36.53	5.70	42.23	46.00	-3.77	QP	100	360
8	770.40	36.90	5.66	42.56	46.00	-3.44	QP	100	360
9	875.40	37.50	5.20	42.70	46.00	-3.30	QP	100	360
10	904.80	36.54	5.60	42.14	46.00	-3.86	QP	100	360
11	910.40	33.33	7.31	40.64	46.00	-5.36	QP	100	360

Notes:

1. Result = Read Value + Factor
2. Factor = Antenna Factor + Cable Loss - Amplifier
3. The resolution bandwidth of test receiver/spectrum analyzer is 120KHz and video bandwidth is 300kHz for Peak detection and Quasi-peak detection at frequency below 1GHz.
4. According to technical experiences, all spurious emission of 802.11a mode at channel 36,44,48 are almost the same below 1GHz, so that the channel 36 was chosen as representative in final test.
5. The data is worse case.

Power : DC 48V from POE
 Test Mode : Transmit/Receive
 Operation Channel: 36
 Modulation Type : 802.11a
 Rate : 54 Mbps
 Memo :

Pol/Phase : HORIZONTAL
 Temperature : 22 °C
 Humidity : 70 %
 Atmospheric Pressure: 1010 hPa

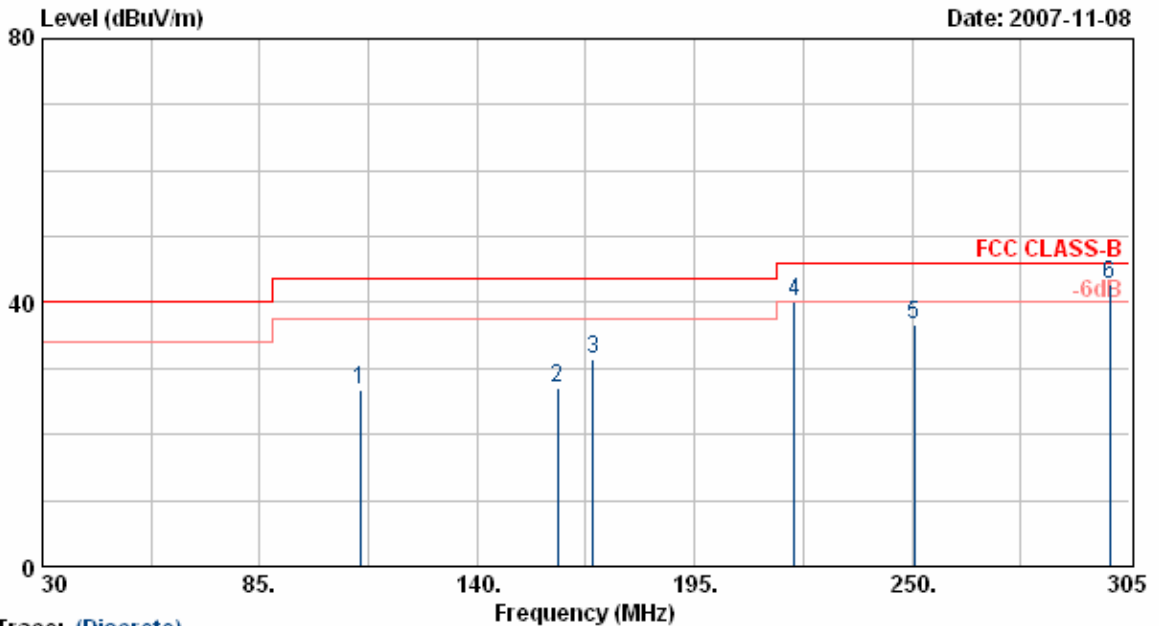

Trace: (Discrete)

Item	Freq	Read Value	Factor	Result	Limit	Margin	Remark	Ant Pos	Tab Pos
	MHz	dBuV/m	dB	dBuV/m	dBuV/m	dB		cm	Deg
1	110.30	41.22	-14.41	26.81	43.50	-16.69	Peak	100	0
2	160.35	38.30	-11.22	27.08	43.50	-16.42	Peak	100	0
3	169.43	42.63	-11.20	31.43	43.50	-12.07	Peak	100	0
4	220.30	50.27	-10.16	40.11	46.00	-5.89	QP	100	0
5	250.55	46.26	-9.72	36.54	46.00	-9.46	Peak	100	0
6	300.05	47.90	-5.06	42.84	46.00	-3.16	QP	100	0

Notes:

1. Result = Read Value + Factor
2. Factor = Antenna Factor + Cable Loss - Amplifier
3. The resolution bandwidth of test receiver/spectrum analyzer is 120KHz and video bandwidth is 300kHz for Peak detection and Quasi-peak detection at frequency below 1GHz.
4. According to technical experiences, all spurious emission of 802.11a mode at channel 36,44,48 are almost the same below 1GHz, so that the channel 36 was chosen as representative in final test.
5. The data is worse case.

Power	: DC 48V from POE	Pol/Phase	: HORIZONTAL
Test Mode	: Transmit/Receive	Temperature	: 22 °C
Operation Channel	: 36	Humidity	: 70 %
Modulation Type	: 802.11a	Atmospheric Pressure	: 1010 hPa
Rate	: 54 Mbps		
Memo	:		

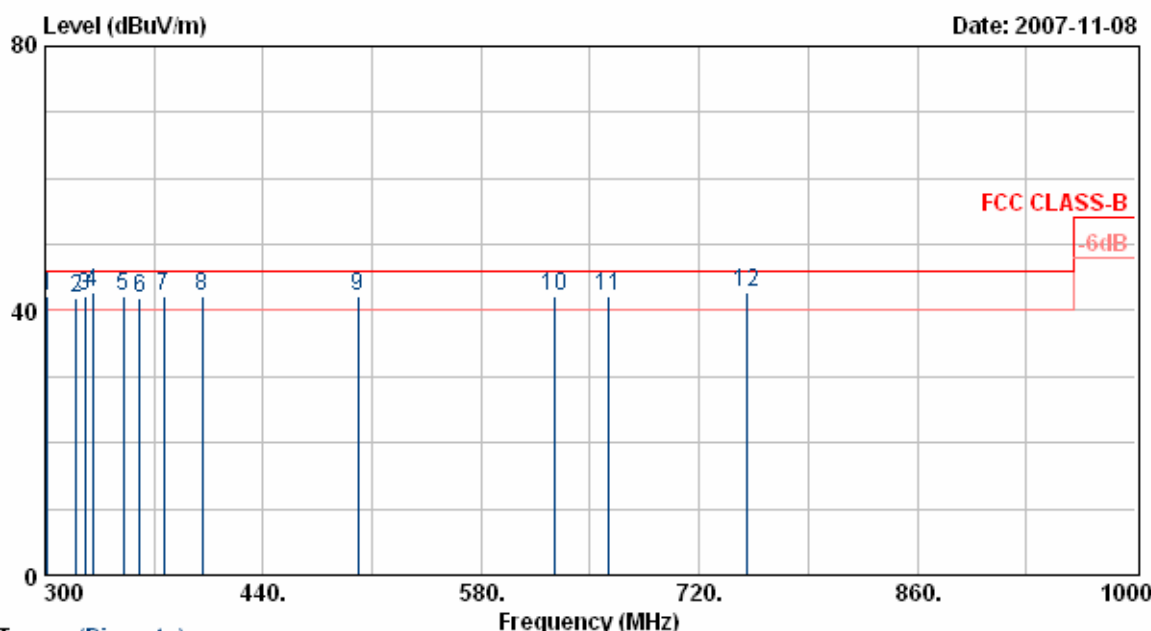

Trace: (Discrete)

Item	Freq MHz	Read Value dBuV/m	Factor dB	Result dBuV/m	Limit dBuV/m	Margin dB	Remark	Ant Pos cm	Tab Pos Deg
1	301.40	47.29	-5.02	42.27	46.00	-3.73	QP	100	360
2	320.30	45.66	-3.64	42.02	46.00	-3.98	QP	100	360
3	325.90	47.23	-5.03	42.20	46.00	-3.80	QP	100	360
4	330.80	48.73	-5.96	42.77	46.00	-3.23	QP	100	360
5	350.40	47.54	-5.50	42.04	46.00	-3.96	QP	100	360
6	360.90	46.32	-4.29	42.03	46.00	-3.97	QP	100	360
7	376.30	44.66	-2.58	42.08	46.00	-3.92	QP	100	360
8	400.80	44.38	-2.13	42.25	46.00	-3.75	QP	100	360
9	500.90	45.50	-3.24	42.26	46.00	-3.74	QP	100	360
10	626.90	40.33	1.76	42.09	46.00	-3.91	QP	100	360
11	661.90	39.11	2.94	42.05	46.00	-3.95	QP	100	360
12	750.80	37.25	5.43	42.68	46.00	-3.32	QP	100	360

- Notes:
1. Result = Read Value + Factor
 2. Factor = Antenna Factor + Cable Loss - Amplifier
 3. The resolution bandwidth of test receiver/spectrum analyzer is 120KHz and video bandwidth is 300kHz for Peak detection and Quasi-peak detection at frequency below 1GHz.
 4. According to technical experiences, all spurious emission of 802.11a mode at channel 36,44,48 are almost the same below 1GHz, so that the channel 36 was chosen as representative in final test.
 5. The data is worse case.

Power : DC 48V from POE
 Test Mode : Transmit/Receive
 Operation Channel: 36
 Modulation Type : 802.11a
 Rate : 54 Mbps
 Memo :

Pol/Phase : VERTICAL
 Temperature : 22 °C
 Humidity : 70 %
 Atmospheric Pressure: 1010 hPa

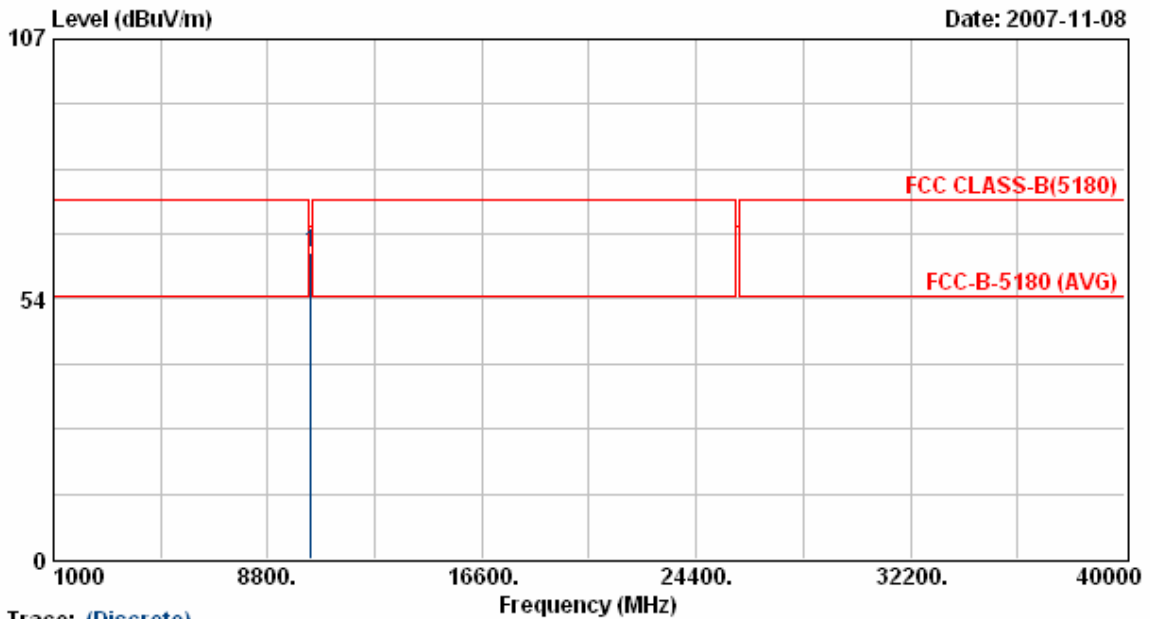

Trace: (Discrete)

Item	Freq	Read Value	Factor	Result	Limit	Margin	Remark	Ant Pos	Tab Pos
	MHz	dBuV/m	dB	dBuV/m	dBuV/m	dB		cm	Deg
1	10360.50	43.98	18.87	62.84	68.30	-5.46	Peak	100	214

Notes:

1. Result = Read Value + Factor
2. Factor = Antenna Factor + Cable Loss - Amplifier
3. The resolution bandwidth of test receiver/spectrum analyzer is 120KHz and video bandwidth is 300kHz for Peak detection and Quasi-peak detection at frequency below 1GHz.
4. The resolution bandwidth of test receiver/spectrum analyzer is 1MHz and video bandwidth is 3MHz for Peak detection at frequency above 1GHz.
5. The resolution bandwidth of test receiver/spectrum analyzer is 1MHz and video bandwidth is 10Hz for Average detection at frequency above 1GHz.
6. The other emissions is too low to be measured.

Power	: DC 48V from POE	Pol/Phase	: HORIZONTAL
Test Mode	: Transmit/Receive	Temperature	: 22 °C
Operation Channel	: 36	Humidity	: 70 %
Modulation Type	: 802.11a	Atmospheric Pressure	: 1010 hPa
Rate	: 54 Mbps		
Memo	:		

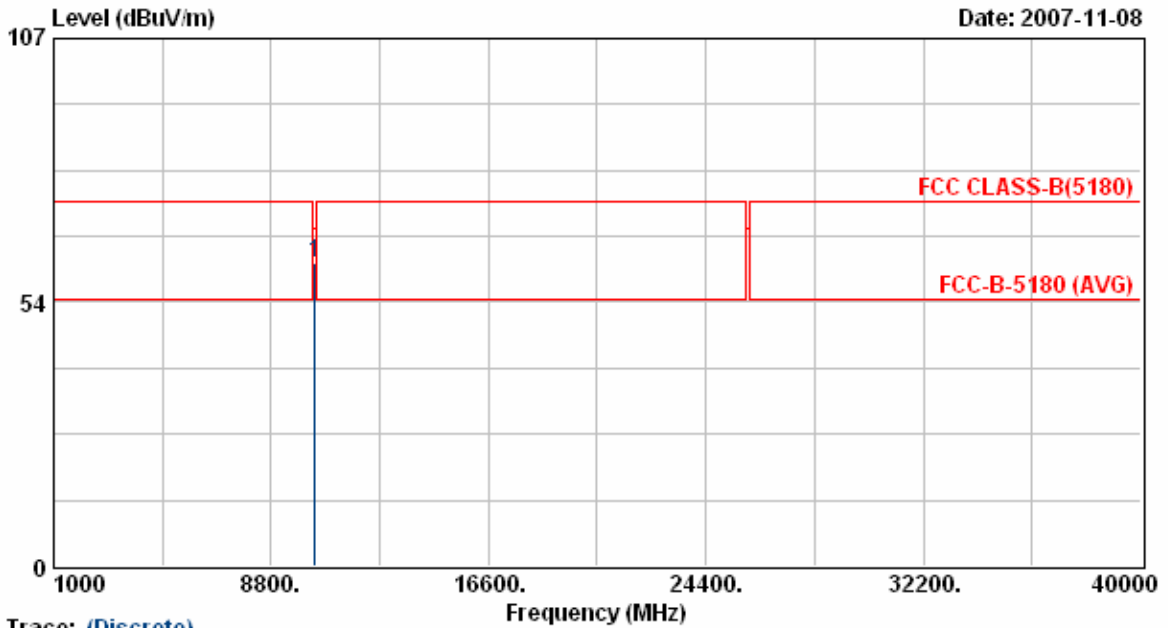

Trace: (Discrete)

Item	Freq	Read Value	Factor	Result	Limit	Margin	Remark	Ant Pos	Tab Pos
	MHz	dBuV/m	dB	dBuV/m	dBuV/m	dB		cm	Deg
1	10360.25	42.53	18.87	61.39	68.30	-6.91	Peak	100	201

- Notes:
1. Result = Read Value + Factor
 2. Factor = Antenna Factor + Cable Loss - Amplifier
 3. The resolution bandwidth of test receiver/spectrum analyzer is 120KHz and video bandwidth is 300kHz for Peak detection and Quasi-peak detection at frequency below 1GHz.
 4. The resolution bandwidth of test receiver/spectrum analyzer is 1MHz and video bandwidth is 3MHz for Peak detection at frequency above 1GHz.
 5. The resolution bandwidth of test receiver/spectrum analyzer is 1MHz and video bandwidth is 10Hz for Average detection at frequency above 1GHz.
 6. The other emissions is too low to be measured.

```

Power          : DC 48V from POE
Test Mode      : Transmit/Receive
Operation Channel : 44
Modulation Type : 802.11a
Rate           : 54 Mbps
Memo           :

Pol/Phase      : VERTICAL
Temperature    : 22 °C
Humidity       : 70 %
Atmospheric Pressure : 1010 hPa
    
```

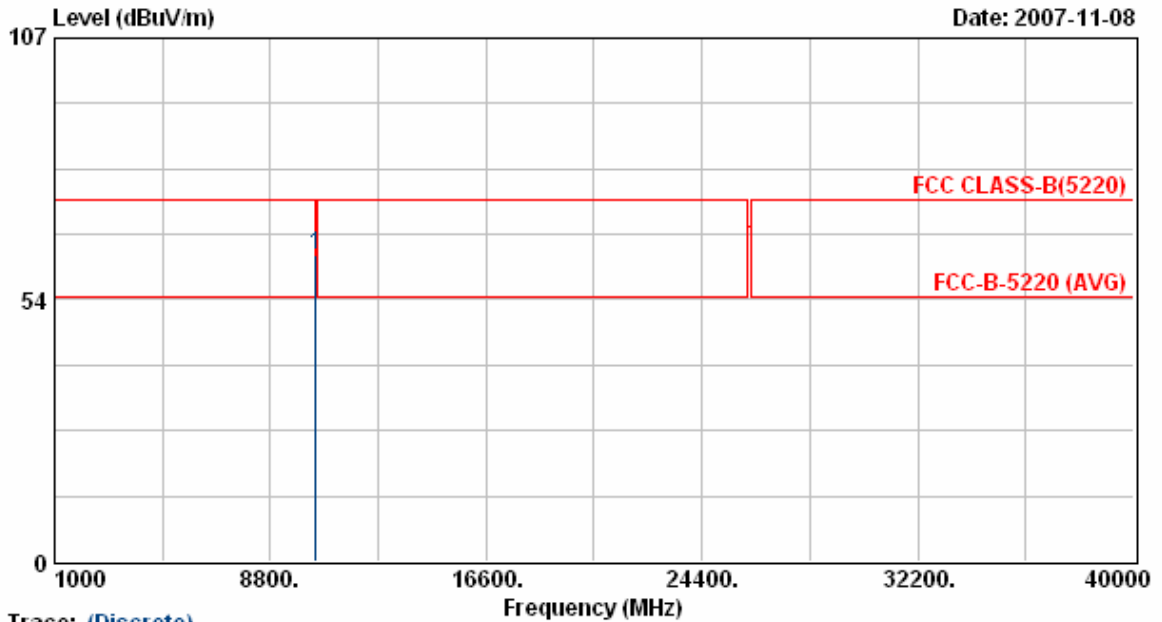

Trace: (Discrete)

Item	Freq	Read Value	Factor	Result	Limit	Margin	Remark	Ant Pos	Tab Pos
	MHz	dBuV/m	dB	dBuV/m	dBuV/m	dB		cm	Deg
1	10440.50	43.73	18.98	62.71	68.30	-5.59	Peak	100	214

Notes:

1. Result = Read Value + Factor
2. Factor = Antenna Factor + Cable Loss - Amplifier
3. The resolution bandwidth of test receiver/spectrum analyzer is 120KHz and video bandwidth is 300kHz for Peak detection and Quasi-peak detection at frequency below 1GHz.
4. The resolution bandwidth of test receiver/spectrum analyzer is 1MHz and video bandwidth is 3MHz for Peak detection at frequency above 1GHz.
5. The resolution bandwidth of test receiver/spectrum analyzer is 1MHz and video bandwidth is 10Hz for Average detection at frequency above 1GHz.
6. The other emissions is too low to be measured.

Power	: DC 48V from POE	Pol/Phase	: HORIZONTAL
Test Mode	: Transmit/Receive	Temperature	: 22 °C
Operation Channel	: 44	Humidity	: 70 %
Modulation Type	: 802.11a	Atmospheric Pressure	: 1010 hPa
Rate	: 54 Mbps		
Memo	:		

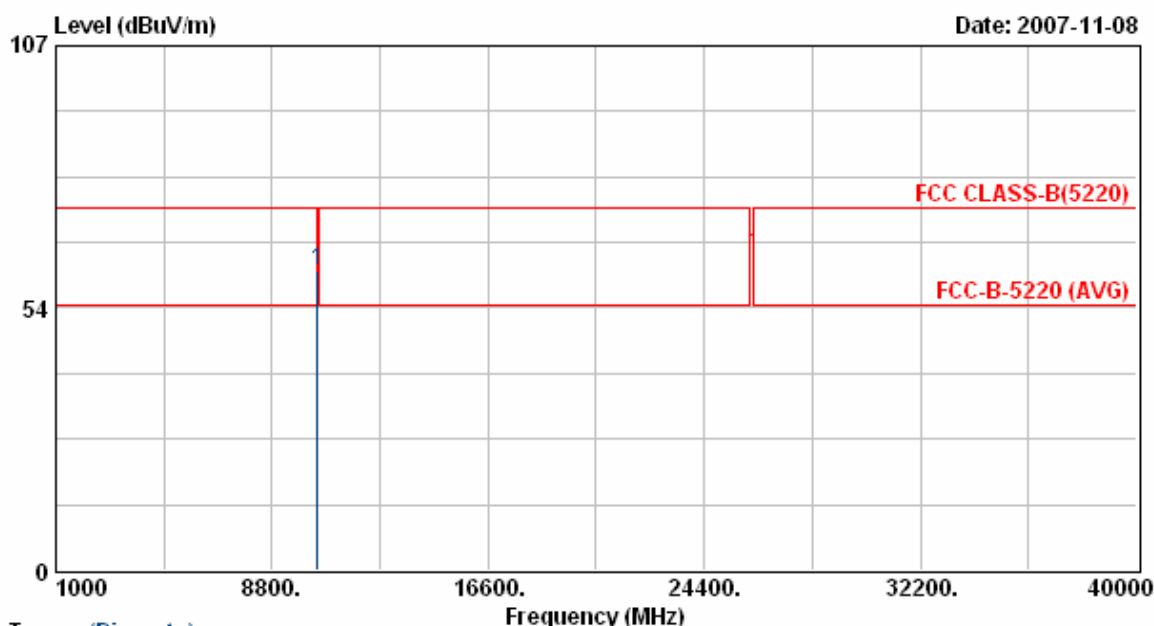

Trace: (Discrete)

Item	Freq	Read Value	Factor	Result	Limit	Margin	Remark	Ant Pos	Tab Pos
	MHz	dBuV/m	dB	dBuV/m	dBuV/m	dB		cm	Deg
1	10440.38	42.19	18.98	61.18	68.30	-7.12	Peak	100	201

Notes:

1. Result = Read Value + Factor
2. Factor = Antenna Factor + Cable Loss - Amplifier
3. The resolution bandwidth of test receiver/spectrum analyzer is 120KHz and video bandwidth is 300kHz for Peak detection and Quasi-peak detection at frequency below 1GHz.
4. The resolution bandwidth of test receiver/spectrum analyzer is 1MHz and video bandwidth is 3MHz for Peak detection at frequency above 1GHz.
5. The resolution bandwidth of test receiver/spectrum analyzer is 1MHz and video bandwidth is 10Hz for Average detection at frequency above 1GHz.
6. The other emissions is too low to be measured.

Power : DC 48V from POE
 Test Mode : Transmit/Receive
 Operation Channel : 48
 Modulation Type : 802.11a
 Rate : 54 Mbps
 Memo :

Pol/Phase : VERTICAL
 Temperature : 22 °C
 Humidity : 70 %
 Atmospheric Pressure : 1010 hPa

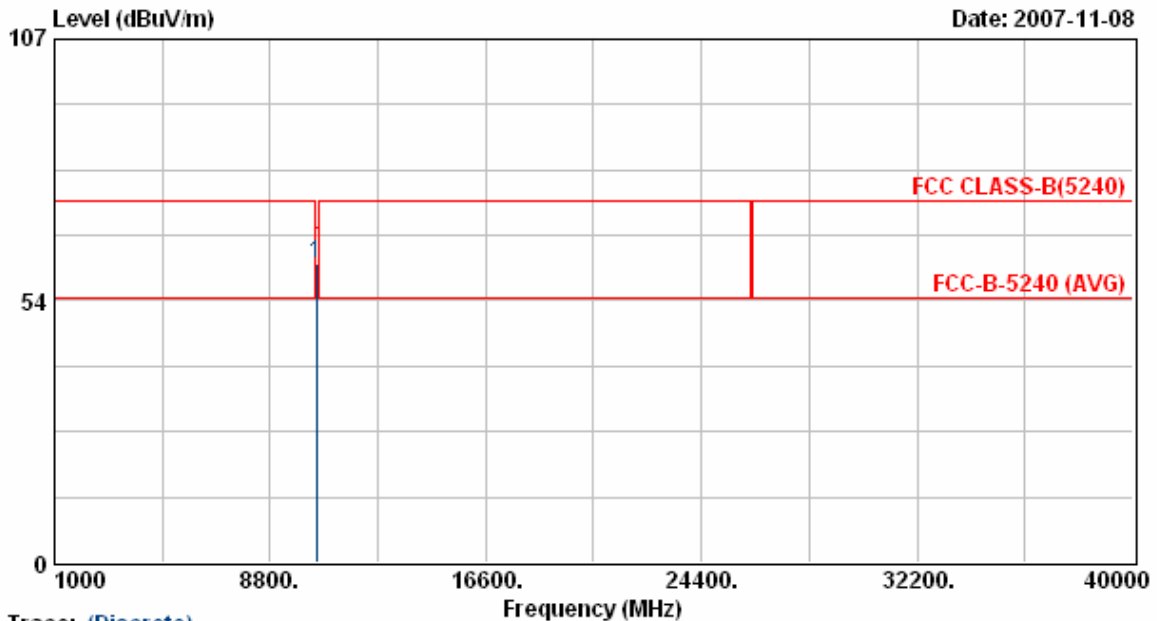

Trace: (Discrete)

Item	Freq	Read Value	Factor	Result	Limit	Margin	Remark	Ant Pos	Tab Pos
	MHz	dBuV/m	dB	dBuV/m	dBuV/m	dB		cm	Deg
1	10480.50	42.04	19.04	61.08	68.30	-7.22	Peak	100	214

- Notes:
1. Result = Read Value + Factor
 2. Factor = Antenna Factor + Cable Loss - Amplifier
 3. The resolution bandwidth of test receiver/spectrum analyzer is 120KHz and video bandwidth is 300kHz for Peak detection and Quasi-peak detection at frequency below 1GHz.
 4. The resolution bandwidth of test receiver/spectrum analyzer is 1MHz and video bandwidth is 3MHz for Peak detection at frequency above 1GHz.
 5. The resolution bandwidth of test receiver/spectrum analyzer is 1MHz and video bandwidth is 10Hz for Average detection at frequency above 1GHz.
 6. The other emissions is too low to be measured.

Power	: DC 48V from POE	Pol/Phase	: HORIZONTAL
Test Mode	: Transmit/Receive	Temperature	: 22 °C
Operation Channel	: 48	Humidity	: 70 %
Modulation Type	: 802.11a	Atmospheric Pressure	: 1010 hPa
Rate	: 54 Mbps		
Memo	:		

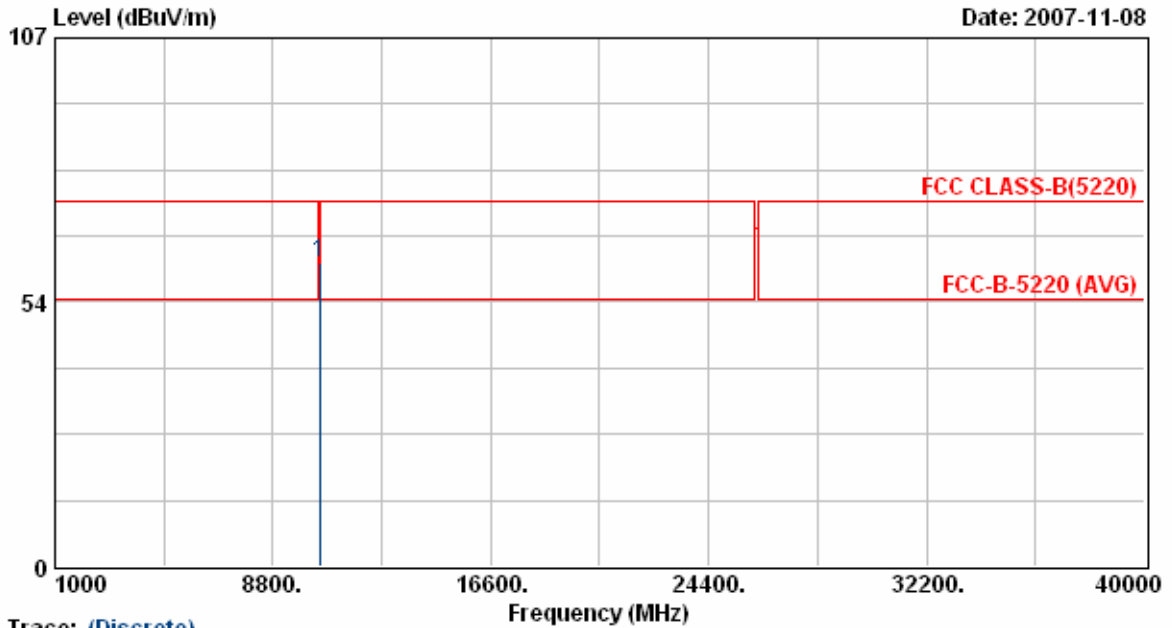

Item	Freq	Read Value	Factor	Result	Limit	Margin	Remark	Ant Pos	Tab Pos
	MHz	dBuV/m	dB	dBuV/m	dBuV/m	dB		cm	Deg
1	10480.63	42.36	19.04	61.40	68.30	-6.90	Peak	100	201

Notes:

1. Result = Read Value + Factor
2. Factor = Antenna Factor + Cable Loss - Amplifier
3. The resolution bandwidth of test receiver/spectrum analyzer is 120KHz and video bandwidth is 300kHz for Peak detection and Quasi-peak detection at frequency below 1GHz.
4. The resolution bandwidth of test receiver/spectrum analyzer is 1MHz and video bandwidth is 3MHz for Peak detection at frequency above 1GHz.
5. The resolution bandwidth of test receiver/spectrum analyzer is 1MHz and video bandwidth is 10Hz for Average detection at frequency above 1GHz.
6. The other emissions is too low to be measured.

6. Peak Transmit Power

6.1. Test Procedure

The antenna port (RF output) of the EUT was connected to the input (RF input) of a spectrum analyzer. Power was read directly from the spectrum analyzer and cable loss connection was added to the reading to obtain power at the EUT antenna terminal. The EUT Output Power was set to maximum to produce the worse case test result.

6.2. Test Setup Layout

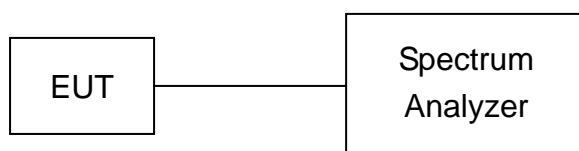

6.3. Measurement equipment

Instrument/Ancillary	Model No.	Manufacturer	Serial No.	Calibration Date	Valid Date.
Spectrum Analyzer	FSP40	R&S	100047	2007/01/23	2008/01/22

6.4. Test Result and Data

Test Mode: Normal, Transmit Rate: 54Mbps

Test Date: Nov. 07, 2007 Temperature: 22 Humidity: 65% Atmospheric pressure: 1010 hPa

Channel	Frequency (MHz)	Peak Power Output (dBm)	Peak Power Output (mW)	26dB Occupied Bandwidth (MHz)
36	5180	14.56	23.30	24.10
44	5220	14.56	28.60	24.30
48	5240	14.38	27.40	24.10

Peak Transmit Power

Modulation Standard: 802.11a (54Mbps)

Channel: 36

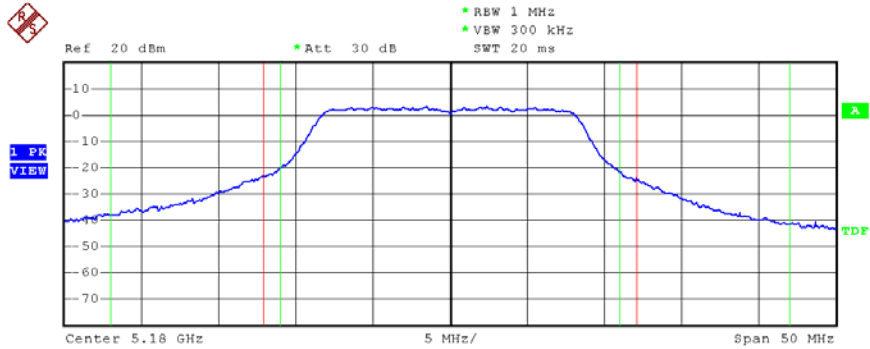

Tx Channel			
Bandwidth	24.1 MHz	Power	13.67 dBm
Adjacent Channel			
Bandwidth	11 MHz	Lower	-32.12 dB
Spacing	16.5 MHz	Upper	-33.84 dB
Alternate Channel			
Bandwidth	11 MHz	Lower	----
Spacing	27.5 MHz	Upper	----

Modulation Standard: 802.11a (54Mbps)

Channel: 44

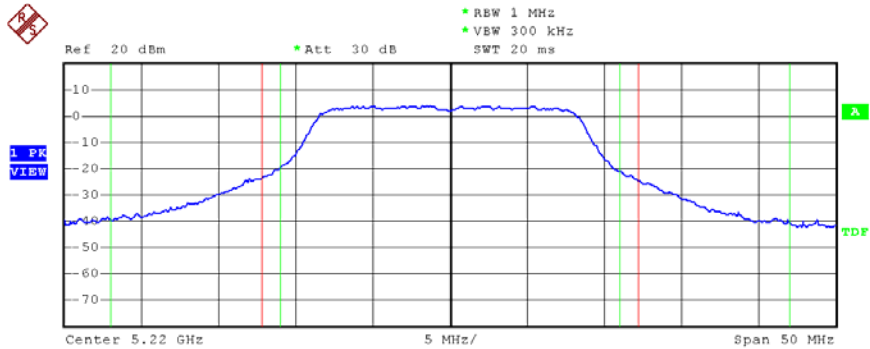

Tx Channel			
Bandwidth	24.3 MHz	Power	14.56 dBm
Adjacent Channel			
Bandwidth	11 MHz	Lower	-32.88 dB
Spacing	16.5 MHz	Upper	-34.13 dB
Alternate Channel			
Bandwidth	11 MHz	Lower	----
Spacing	27.5 MHz	Upper	----

Modulation Standard: 802.11a (54Mbps)
 Channel: 48

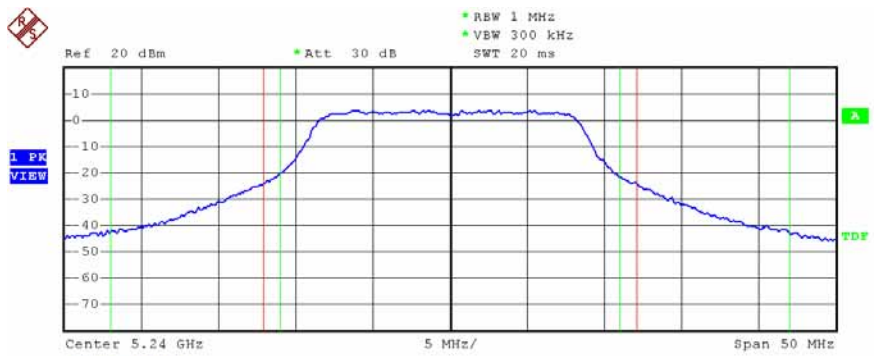

Tx Channel			
Bandwidth	24.1 MHz	Power	14.38 dBm
Adjacent Channel			
Bandwidth	11 MHz	Lower	-33.77 dB
Spacing	16.5 MHz	Upper	-34.36 dB
Alternate Channel			
Bandwidth	11 MHz	Lower	----
Spacing	27.5 MHz	Upper	----

26dB Occupied Bandwidth (MHz)

Modulation Standard: 802.11a (54Mbps)

Channel: 36

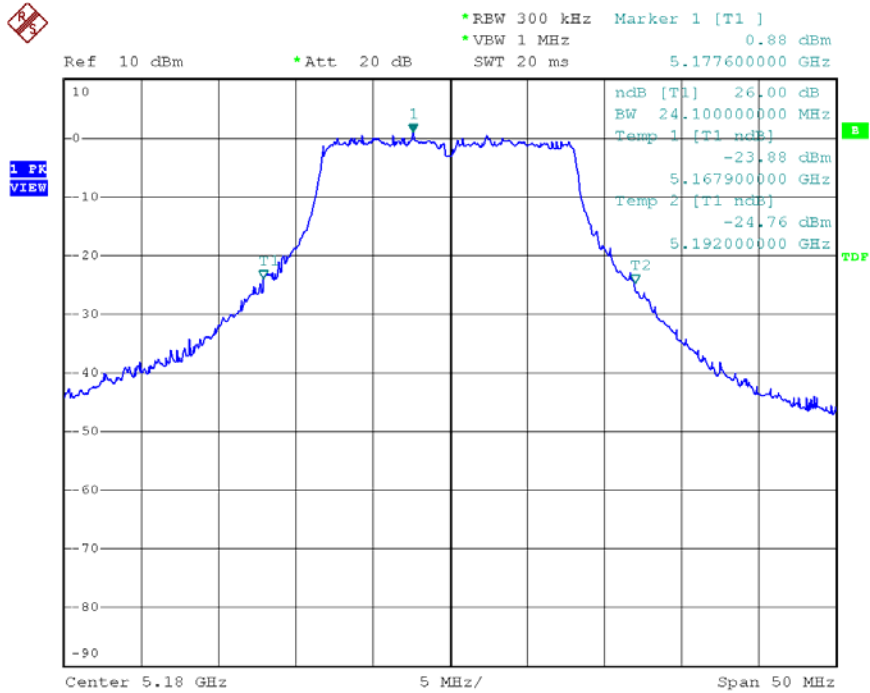

Modulation Standard: 802.11a (54Mbps)

Channel: 44

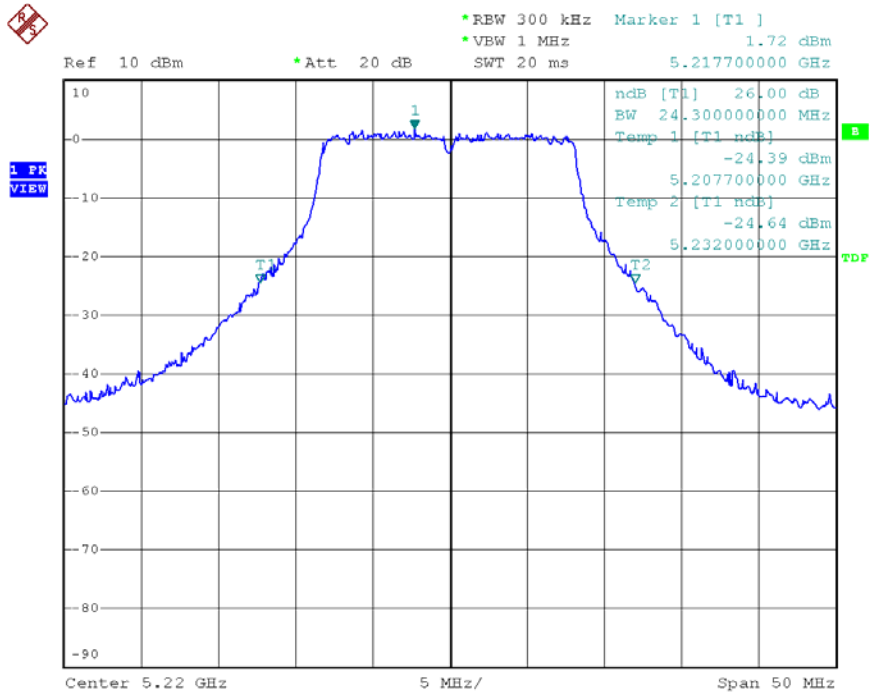

Modulation Standard: 802.11a (54Mbps)
 Channel: 48

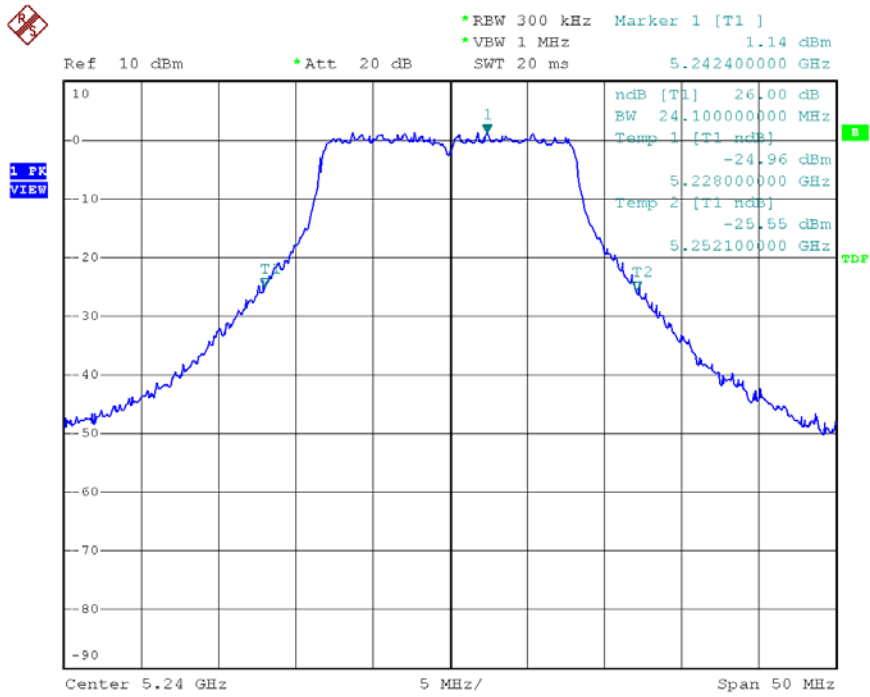

7. Peak Power Excursion

7.1. Test Procedure

1. The transmitter output was connected to the spectrum analyzer
2. Using Peak detector and max-hold function for Trace 1 MHz and VBW to 3 MHz for Trace 1.
3. Set RBW of spectrum analyzer to 1 MHz and VBW to 3 MHz for Trace 1.
Set RBW of spectrum analyzer to 1 MHz and VBW to 300 kHz for Trace 2.
4. The largest difference between Trace 1 and Trace 2 in any 1 MHz band on any frequency was recorded.

7.2. Test Setup Layout

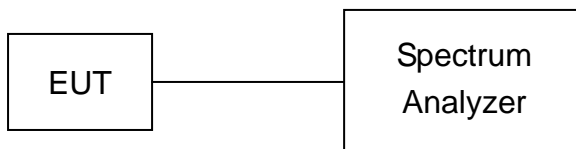

7.3. Measurement equipment

Instrument/Ancillary	Model No.	Manufacturer	Serial No.	Calibration Date	Valid Date.
Spectrum Analyzer	FSP40	R&S	100047	2007/01/23	2008/01/22

7.4. Test Result and Data

Test Mode: Normal, Transmit Rate: 54Mbps

Test Date: Nov. 07, 2007 Temperature: 22 Humidity: 65% Atmospheric pressure: 1010 hPa

Channel	Frequency (MHz)	Peak Power Excursion (dB)
36	5180	8.59
44	5220	8.29
48	5240	7.58

Modulation Standard: 802.11a (54Mbps)
 Channel: 36

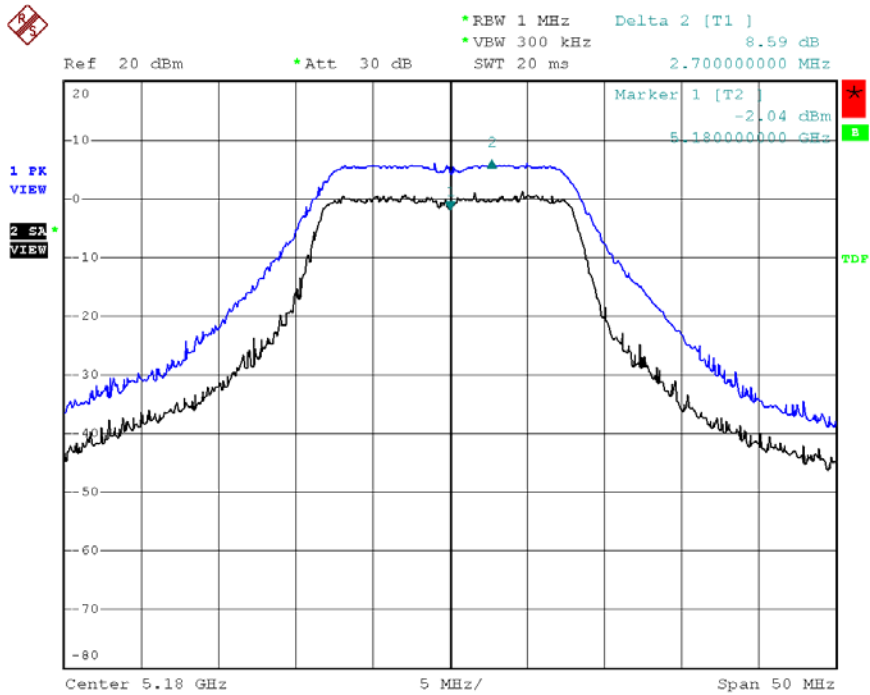

Modulation Standard: 802.11a (54Mbps)
 Channel: 44

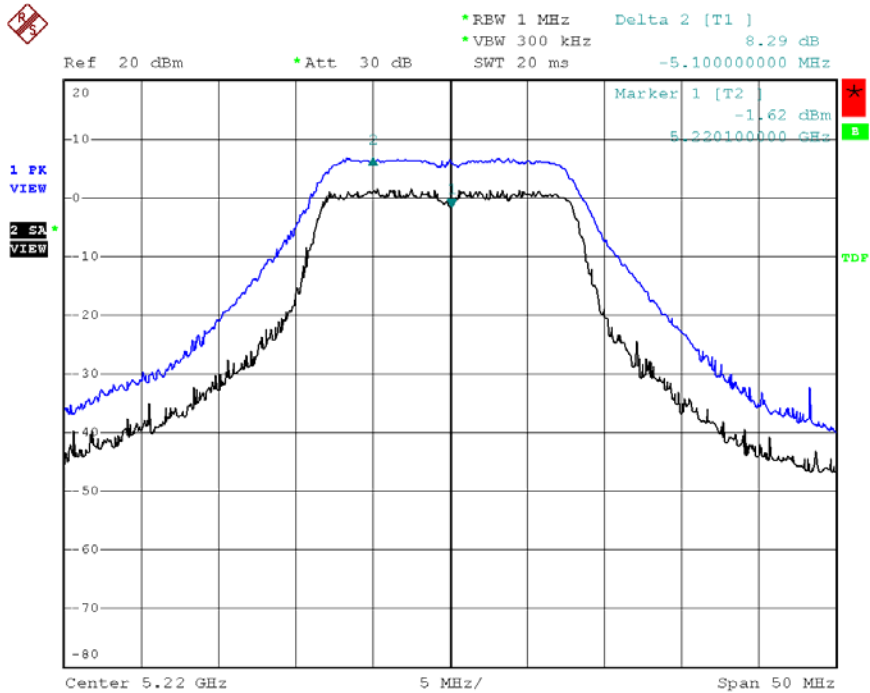

Modulation Standard: 802.11a (54Mbps)
 Channel: 48

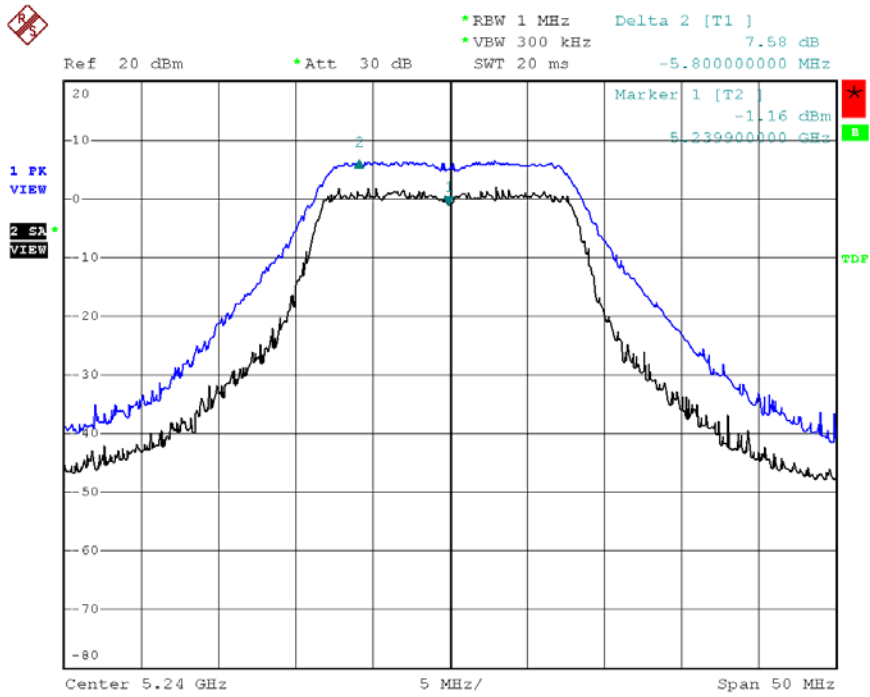

8. Peak Power Spectral Density

8.1. Test Procedure

1. The transmitter output was connected to spectrum analyzer.
2. Set RBW of spectrum analyzer to 1 MHz and VBW to 3 MHz
3. The Peak Power Spectral Density is the highest level found across the emission in any 1MHz Band

8.2. Test Setup Layout

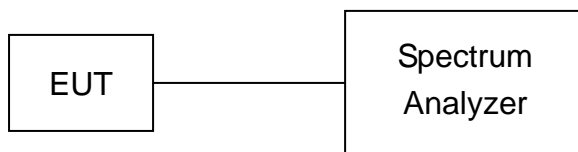

8.3. Measurement equipment

Instrument/Ancillary	Model No.	Manufacturer	Serial No.	Calibration Date	Valid Date.
Spectrum Analyzer	FSP40	R&S	100047	2007/01/23	2008/01/22

8.4. Test Result and Data

Test Mode: Normal, Transmit Rate: 54Mbps

Test Date: Nov. 07, 2007 Temperature: 22 Humidity: 65% Atmospheric pressure: 1010 hPa

Channel	Frequency (MHz)	PF Power Level In 1MHz BW (dBm)
36	5180	3.58
44	5220	2.58
48	5240	3.22

Modulation Standard: 802.11a (54Mbps)
 Channel: 36

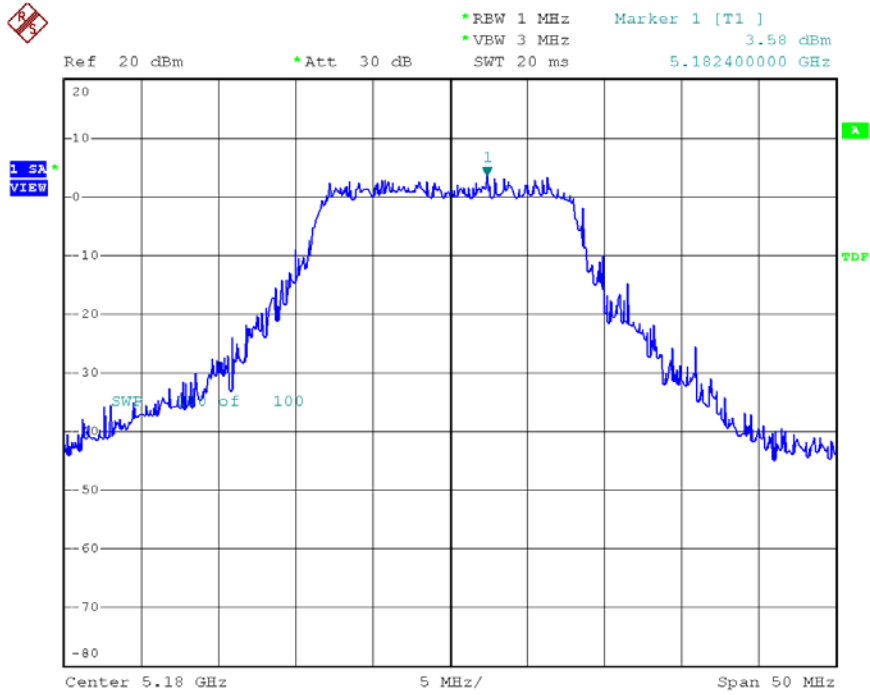

Modulation Standard: 802.11a (54Mbps)
 Channel: 44

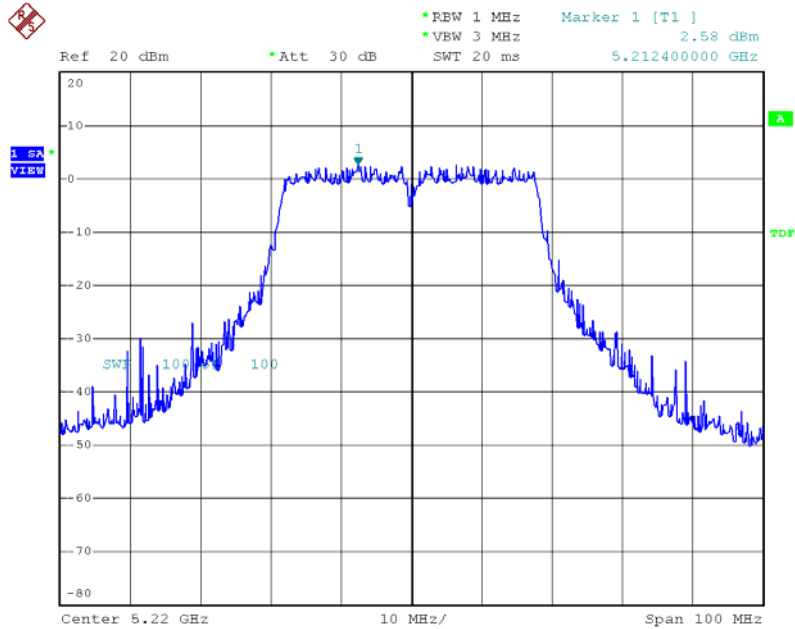

Date: 19.DEC.2007 17:23:20

Modulation Standard: 802.11a (54Mbps)
Channel: 48

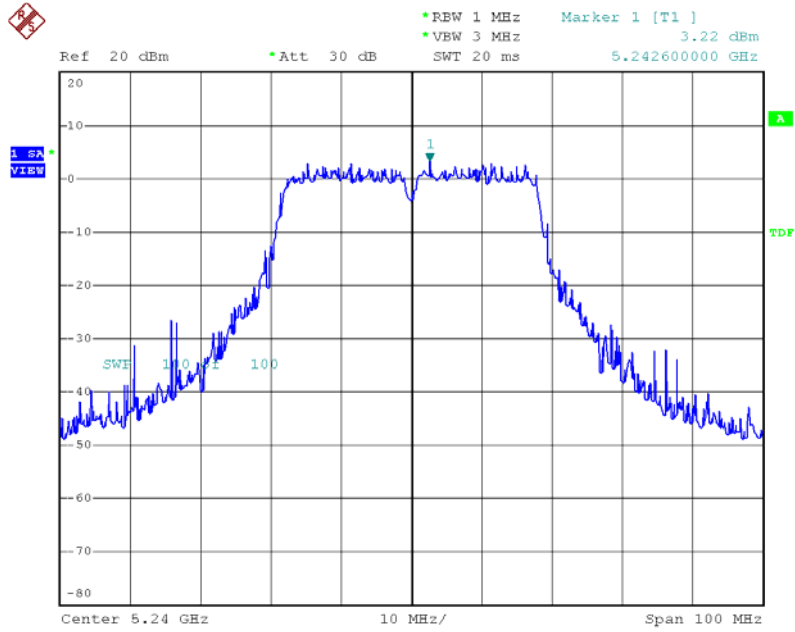

Date: 19.DEC.2007 17:23:57

9. Frequency Stability

9.1. Test Procedure

1. The EUT was placed inside the Temperature and Humidity chamber.
2. The transmitter output was connected to spectrum analyzer.
3. Turn the EUT on and couple its output to a spectrum analyzer.
4. Turn the EUT off and set the chamber to the highest temperature specified.
5. Allow sufficient time (approximately 30 min) for the temperature of the chamber to stabilize, turn the EUT on and measure the operating frequency after 2, 5, and 10 minutes.
6. Repeat step 2 and 3 with the temperature chamber set to the lowest temperature.
7. The test chamber was allowed to stabilize at +20 degree C for a minimum of 30 minutes. The supply voltage was then adjusted on the EUT from 85% to 115% and the frequency record.

9.2. Test Setup Layout

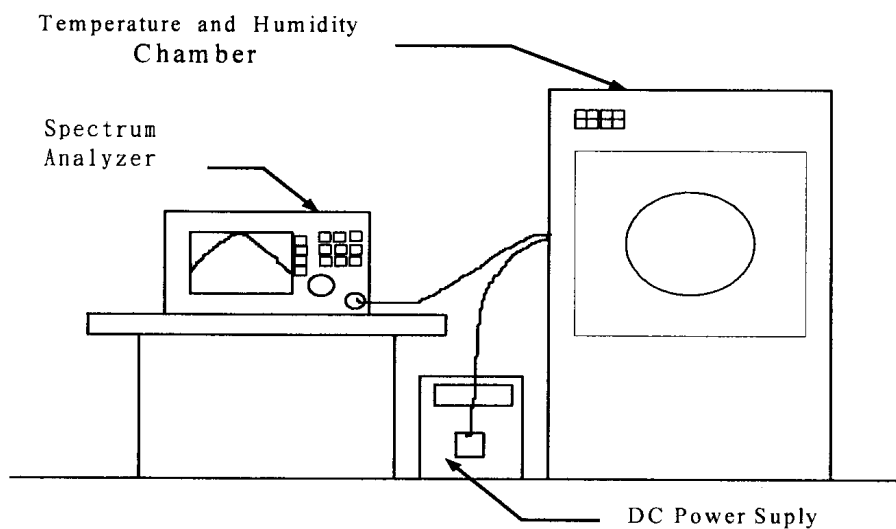

9.3. Measurement equipment

Instrument/Ancillary	Model No.	Manufacturer	Serial No.	Calibration Date	Valid Date.
Spectrum Analyzer	FSP40	R&S	100047	2007/01/23	2008/01/22
Temperature Chamber	TMJ-9712	T MACHINE	T-12-040111	2007/01/24	2008/01/23
DC Power Supply	GPD-3030	GM	7020936	N/A	N/A
AC POWER CONVERTER	AFC-11005	APC	F103120008	N/A	N/A

9.4. Test Result and Data

Operating frequency: 5240 MHz							
Temp (°C)	Power supply (V)	2 minute		5 minute		10 minute	
		(MHz)	(%)	(MHz)	(%)	(MHz)	(%)
50	93.5	5239.97362	-0.000503	5239.9704	-0.000565	5239.98482	-0.000290
	110	5239.9859	-0.000269	5239.9842	-0.000302	5239.96422	-0.000683
	126.5	5239.98988	-0.000193	5239.9678	-0.000615	5239.97714	-0.000436
40	93.5	5239.9882	-0.000225	5239.9879	-0.000231	5240.18258	0.003484
	110	5239.96528	-0.000663	5240.1617	0.003086	5239.9755	-0.000468
	126.5	5239.98398	-0.000306	5239.9888	-0.000214	5239.97248	-0.000525
30	93.5	5239.98432	-0.000299	5240.0116	0.000221	5239.96222	-0.000721
	110	5239.98144	-0.000354	5240.1731	0.003303	5239.94282	-0.001091
	126.5	5239.98082	-0.000366	5240.0823	0.001571	5239.976	-0.000458
20	93.5	5240.01896	0.000362	5240.0079	0.000151	5240.00416	0.000079
	110	5240.0168	0.000321	5239.9836	-0.000313	5240.1529	0.002918
	126.5	5240.00656	0.000125	5240.0148	0.000282	5239.94	-0.001145
10	93.5	5240.0143	0.000273	5240.017	0.000324	5240.01596	0.000305
	110	5240.0085	0.000162	5239.9569	-0.000823	5240.03234	0.000617
	126.5	5240.00572	0.000109	5240.0257	0.000490	5239.99398	-0.000115
0	93.5	5239.93776	-0.001188	5239.9288	-0.001359	5239.92976	-0.001340
	110	5239.9281	-0.001372	5239.9278	-0.001378	5239.92946	-0.001346
	126.5	5239.92617	-0.001409	5239.9383	-0.001177	5239.93036	-0.001329
-10	93.5	5240.02858	0.000545	5239.9858	-0.000271	5240.02554	0.000487
	110	5240.02832	0.000540	5240.0289	0.000552	5240.0294	0.000561
	126.5	5239.95678	-0.000825	5239.93	-0.001336	5239.92838	-0.001367
-20	93.5	5240.0313	0.000597	5240.0391	0.000746	5240.02282	0.000435
	110	5240.01144	0.000218	5240.0201	0.000384	5240.02792	0.000533
	126.5	5240.02272	0.000434	5240.0218	0.000416	5240.02398	0.000458
-30	93.5	5240.01524	0.000291	5240.0095	0.000181	5240.02611	0.000498
	110	5240.0142	0.000271	5240.0196	0.000374	5240.03366	0.000642
	126.5	5240.02153	0.000411	5240.0193	0.000368	5240.02791	0.000533

Limit :

Manufacturers of U-NII devices are responsible for ensuring frequency stability such that an emission is maintained within the band of operation under all conditions of normal operation as specified in the users manual.

10. Band Edges Measurement

10.1. Test Procedure

1. The transmitter output was connected to the spectrum analyzer via a low lose cable.
2. Set both RBW and VBW of spectrum analyzer to 100 KHz with convenient frequency span including 100 MHz bandwidth from band edge
3. The band edges was measured and recorded..

10.2. Measurement equipment

Instrument/Ancillary	Model No.	Manufacturer	Serial No.	Calibration Date	Valid Date
EMI Receiver	85460A	HP	3807A00454	2007/06/05	2008/06/04
Spectrum Analyzer	FSP40	R&S	10047	2007/01/23	2008/01/22
Horn Antenna	3115	EMCO	31589	2007/03/05	2008/03/04
Horn Antenna	3116	EMCO	31970	2007/03/06	2008/03/05
Bilog Antenna	CBL6112B	Schaffner	2840	2007/04/26	2008/04/25
Amplifier	8449B	Agilent	3008A01954	2007/01/12	2008/01/11
Amplifier	8447D	Agilent	2944A10531	2006/09/11	2007/09/10
Amplifier	PA-840	Com-Power	711885	2007/08/28	2008/08/27

10.3. Test Result and Data

Test Mode: Normal, Transmit Rate: 54Mbps

Test Date: Nov. 07, 2007 Temperature: 22 Humidity: 65% Atmospheric pressure: 1010 hPa

Channel	Frequency (MHz)	Maximum Value In Frequency (MHz)	Maximum Value (dBm)
36	5180	5147.80	-37.33

Modulation Standard: 802.11a (54Mbps)
 Channel: 48

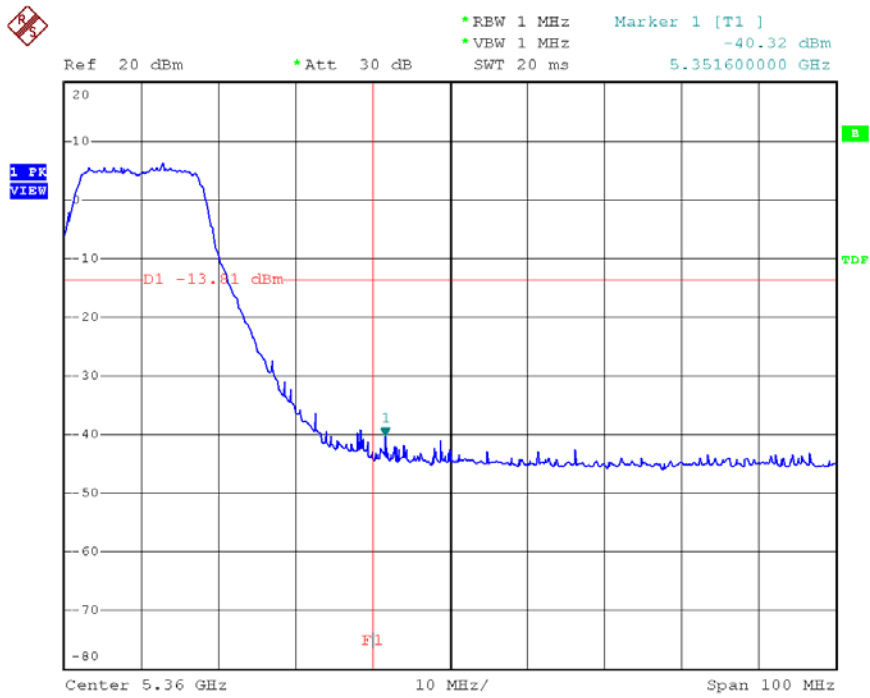
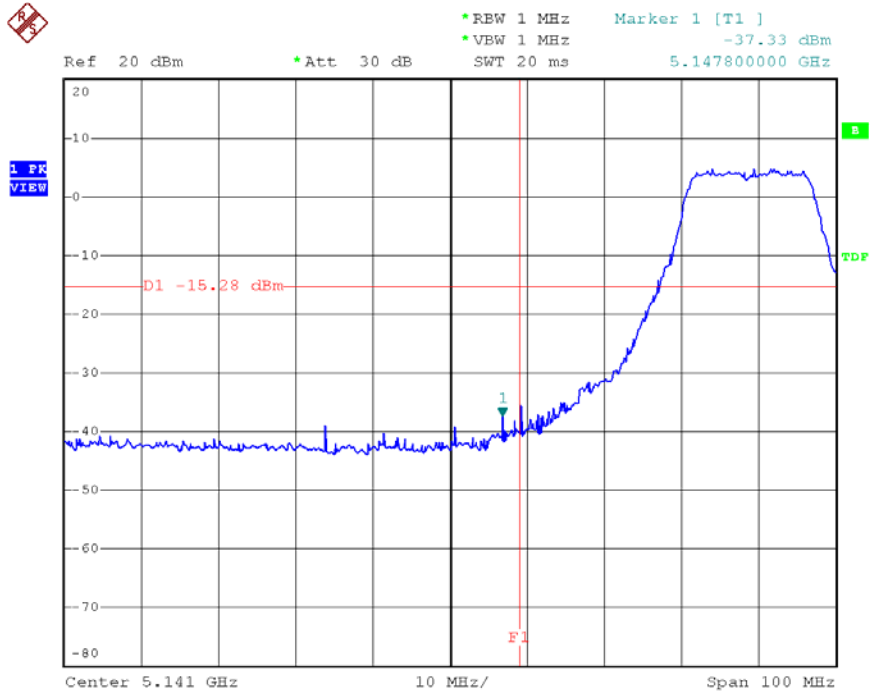

10.4. Restrict Band Emission Measurement Data

Test Mode 1: Normal, Transmit Rate: 54Mbps

Test Date: Nov. 08, 2007 Temperature: 22 Humidity: 70% Atmospheric pressure: 1010 hPa

Channel 01, Fundamental Frequency: 5180 MHz

Frequency (MHz)	Ant-Pol H/V	Meter Reading (dBuV)		Corrected Factor (dB)	Result (dBuV/m)		Limit (dBuV/m)		Margin (dB)	Table Deg.	Ant High (m)
		Peak	Ave		Peak	Ave	Peak	Ave			
5149.90	H	41.88	30.58	9.61	51.49	40.19	74	54	-13.81	201	1.0
5149.90	V	45.62	34.43	9.61	55.23	44.04	74	54	-9.96	214	1.0

Notes:

1. Result = Meter Reading + Factor
2. Factor = Antenna Factor + Cable Loss – Amplifier
3. The resolution bandwidth of test receiver/spectrum analyzer is 1MHz and video bandwidth is 3 MHz for Peak detection at frequency above 1GHz.
4. The resolution bandwidth of test receiver/spectrum analyzer is 1MHz and video bandwidth is 10 MHz for Average detection at frequency above 1GHz.

Test Mode 2: Normal, Transmit Rate: 54Mbps

Test Date: Nov. 08, 2007 Temperature: 22 Humidity: 70% Atmospheric pressure: 1010 hPa

Channel 01, Fundamental Frequency: 5180 MHz

Frequency (MHz)	Ant-Pol H/V	Meter Reading (dBuV)		Corrected Factor (dB)	Result (dBuV/m)		Limit (dBuV/m)		Margin (dB)	Table Deg.	Ant High (m)
		Peak	Ave		Peak	Ave	Peak	Ave			
5149.90	H	41.62	30.11	9.61	51.24	39.72	74	54	-14.28	201	1.0
5149.90	V	45.13	34.02	9.61	54.74	43.63	74	54	-10.37	214	1.0

Notes:

1. Result = Meter Reading + Factor
2. Factor = Antenna Factor + Cable Loss – Amplifier
3. The resolution bandwidth of test receiver/spectrum analyzer is 1MHz and video bandwidth is 3 MHz for Peak detection at frequency above 1GHz.
4. The resolution bandwidth of test receiver/spectrum analyzer is 1MHz and video bandwidth is 10 MHz for Average detection at frequency above 1GHz.

11. Restricted Bands of Operation

Only spurious emissions are permitted in any of the frequency bands listed below:

MHz	MHz	MHz	GHz
0.09000 – 0.11000	16.42000 – 16.42300	399.9 – 410.0	4.500 – 5.250
0.49500 – 0.505**	16.69475 – 16.69525	608.0 – 614.0	5.350 – 5.460
2.17350 – 2.19050	16.80425 – 16.80475	960.0 – 1240.0	7.250 – 7.750
4.12500 – 4.12800	25.50000 – 25.67000	1300.0 – 1427.0	8.025 – 8.500
4.17725 – 4.17775	37.50000 – 38.25000	1435.0 – 1626.5	9.000 – 9.200
4.20725 – 4.20775	73.00000 – 74.60000	1645.5 – 1646.5	9.300 – 9.500
6.21500 – 6.21800	74.80000 – 75.20000	1660.0 – 1710.0	10.600 – 12.700
6.26775 – 6.26825	108.00000 – 121.94000	1718.8 – 1722.2	13.250 – 13.400
6.31175 – 6.31225	123.00000 – 138.00000	2200.0 – 2300.0	14.470 – 14.500
8.29100 – 8.29400	149.90000 – 150.05000	2310.0 – 2390.0	15.350 – 16.200
8.36200 – 8.36600	156.52475 – 156.52525	2483.5 – 2500.0	17.700 – 21.400
8.37625 – 8.38675	156.70000 – 156.90000	2655.0 – 2900.0	22.010 – 23.120
8.41425 – 8.41475	162.01250 – 167.17000	3260.0 – 3267.0	23.600 – 24.000
12.29000 – 12.29300	167.72000 – 173.20000	3332.0 – 3339.0	31.200 – 31.800
12.51975 – 12.52025	240.00000 – 285.00000	3345.8 – 3358.0	36.430 – 36.500
12.57675 – 12.57725	322.00000 – 335.40000	3600.0 – 4400.0	Above 38.6
13.36000 – 13.41000			

** : Until February 1, 1999, this restricted band shall be 0.490-0.510 MHz

11.1. Labeling Requirement

The device shall bear the following statement in a conspicuous location on the device:

This device complies with part 15 of the FCC Rules. Operation is subject to the following two conditions: (1) This device may not cause harmful interference, and (2) this device must accept any interference received, including interference that may cause undesired operation.

12. RF Exposure

FCC Rules and Regulations Part 1.1307, 1.1310, 2.1091, 2.1093:
RF Exposure Compliance

12.1. Limit for Maximum Permissible Exposure (MPE)

(A) Limits for Occupational / Controlled Exposure

Frequency Range (MHz)	Electric Field Strength (E) (V/m)	Magnetic Field Strength (H) (A/m)	Power Density (S) (mW/ cm ²)	Averaging Time E ² , H ² or S (minutes)
0.3-3.0	614	1.63	(100)*	6
3.0-30	1842/f	4.89/f	(900/f)*	6
30-300	61.4	0.163	1.0	6
300-1500			F/300	6
1500-100,000			5	6

(B) Limits for General Population / Uncontrolled Exposure

Frequency Range (MHz)	Electric Field Strength (E) (V/m)	Magnetic Field Strength (H) (A/m)	Power Density (S) (mW/cm ²)	Averaging Time E ² , H ² or S (minutes)
0.3-1.34	614	1.63	(100)*	30
1.34-30	824/f	2.19/f	(180/f)*	30
30-300	27.5	0.073	0.2	30
300-1500			F/1500	30
1500-100,000			1.0	30

F=frequency in MHz

*Plane-wave equivalent power density

12.2. MPE Calculations

$$E \text{ (V/m)} = \frac{\sqrt{30 \times P \times G}}{d} \quad \text{Power Density: } Pd \text{ (mW/cm}^2\text{)} = \frac{E^2}{3770}$$

E = Electric field (V/m)

P = Peak output power (W)

G = Antenna numeric gain (numeric)

d = Separation distance (m)

Because the EUT is belong to General Population/ Uncontrolled Exposure. So the Limit of Power Density is 10 W/m². We can change the formula to:

$$d = \sqrt{\frac{30 \times P \times G}{3770}}$$

12.3. FCC Radiation Exposure Statement

This equipment complies with FCC radiation exposure limits set forth for an uncontrolled environment. In order to avoid the possibility of exceeding the FCC radio frequency exposure limits, human proximity to the antenna shall not be less than 20cm (8 inches) during normal operation. Proposed RF exposure safety information to include in User's Manual.