

WHA YU INDUSTRIAL CO., LTD. (HEAD OFFICE)  
TAI HWA ELECTRONIC CO., LTD.(CHINA)  
SHANGHAI HUA YU ELECTRONIC CO., LTD.(CHINA)  
AEON TECH CO., LTD. (CHINA)

## SPECIFICATION FOR APPROVAL

**CUSTOMER:** 中磊科技股份有限公司

**PART NAME:** RF Antenna Assembly

**PART NO.:**

**REVISION:**

**W. Y. P/NO.:** C147-510097-A

**REV.:** X1

	MANUFACTURER SIGNATURE	CUSTOMER SIGNATURE
APPROVED BY :	<i>Winston</i>	
DATE :	2004/6/15	

### WHA YU GROUP

WHA YU INDUSTRIAL CO., LTD.(HEAD OFFICE)

譚裕實業股份有限公司

Address: #70 Shui Li Road, Hsin Chu City, Taiwan, R.O.C.

Tel: +886-3-5714225(REP.)

Fax: + 886-3-5713853 · + 886-3-5723600

TAI HWA ELECTRONIC CO., LTD. (CHINA)

台樺電業製品廠

Address: Pak Ho District, Hiu Street Town, Dong Guan City, Guangdong, China

Tel: + 86-769-5599375 · + 86-769-5912375

Fax: + 86-769-5599376

HUA HONG INTERNATIONAL LTD.

華弘國際有限公司

Rm.1103A, President Commercial Centre, 608 Nathan Road, Mong Kok, Kowloon, Hong Kong

Tel: + 86-852-27712210

Fax: + 86-852-23843747

SHANGHAI HUA YU ELECTRONIC CO., LTD. (CHINA)

上海譚裕電子有限公司

Address: 3586, Wai Qing Song Road, Qing Pu County, Shanghai China

Tel: + 86-21-59741348 · + 86-21-59744101~4

Fax: + 86-21-59741347

SU ZHOU AEON TECH CO., LTD. (CHINA)

蘇州華廣電通有限公司

Address: Limin North Road, LiLi Town, LiLi Industrial Park, LinHu Economic Zone

Wujiang City, Jiangsu Province, China

Tel: + 86-512-63627980

Fax: + 86-512-63627981

# ***INDEX***

<i><b>Item</b></i>	<i><b>Content</b></i>	<i><b>Page</b></i>
1. ....	天線規格表	..... 1
2. ....	成品圖	..... 2
3. ....	測試報告	..... 3~7
4. ....	<b>Cable</b> 規格	..... 8~12
5. ....	天線桿套材質特性	..... 13~19
6. ....	天線固定座材質特性	..... 20
7. ....	<b>Connector</b> 材質特性	..... 21~30
8. ....	膠水特性及黏著力	..... 31~35

# Dual Band RF Antenna Cable Assembly

## Specification

### 1. Electrical Properties :

- 1.1 Frequency Rang..... 2.4GHz ~ 2.5GHz & 4.9GHz~5.825GHz
- 1.2 Impedance ..... 50  $\Omega$  Nominal
- 1.3 VSWR ..... 1.92 Max.
- 1.4 Return Loss..... -10 dB Maximum
- 1.5 Electrical Wave.....  $1/2 \lambda$  Diople
- 1.6 Gain..... 1dBi@2.45GHz (Real Test)  
1dBi@5.825GHz (Real Test)
- 1.7 Admitted Power..... 1W

### 2. Physical Properties :

- 2.1 Cable.....  $\phi$  1.13 Coaxial Cable
- 2.2 Antenna Cover..... TPE
- 2.3 Antenna Base..... PC
- 2.4 Operating Temp. .... -20°C ~ +65°C
- 2.5 Storage Temp. .... -30°C ~ +75°C
- 2.6 Color ..... Black
- 2.7 Connector..... MHF Connector

REV	DATE	DESCRIPTION
X1	06/10-2004	Initial Sample Request

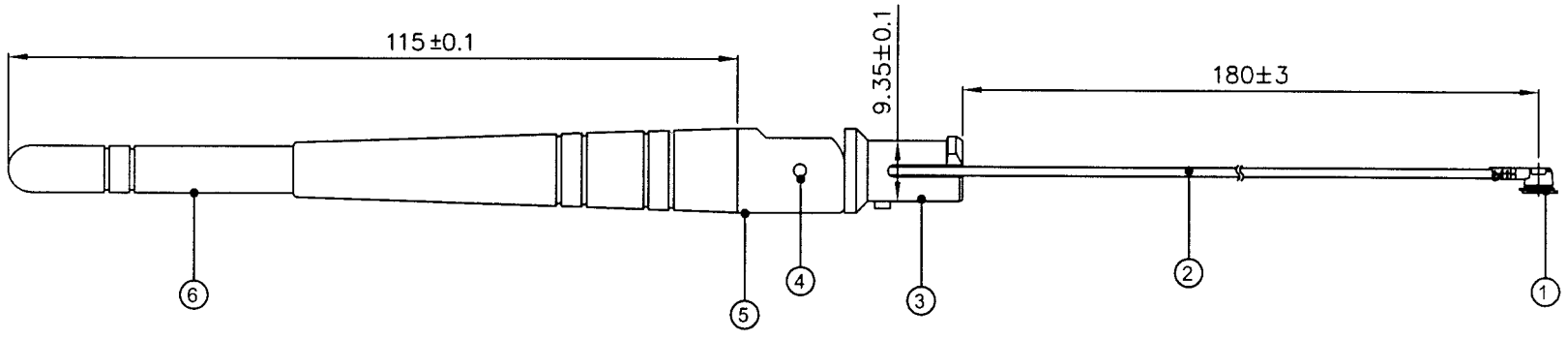
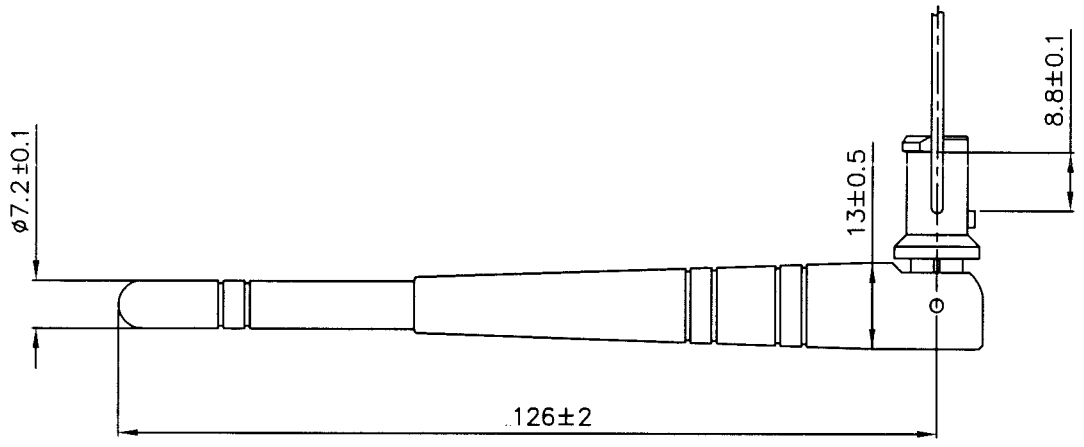

NO	DESCRIPTION	QTY	REMARK
6	Antenna Cover	TPE (Black)	1
5	Antenna Base	PC (Black)	1
4	Rivet	Brass ,Black Surfaced	2
3	Antenna Base	PC (Black)	1
2	Cable	ø1.13 Coaxial Cable	1
1	Connector	I-PEX Connector	1

CUSTOMER'S SIGNATURE	XX. ±5	APPROVED	CUSTOMER: 中磊科技股份有限公司	
	X. ±3.0	<i>Winston</i>		PART NO :
	.X ±1.0	CHECKED		PARTNAME: Dual Band RF Antenna Assembly
	.XX ±0.5	<i>[Signature]</i>		W.Y P/NO : C147-510097-A
	.XXX ±0.1	DRAWING		REV UNIT FILE :
		<i>[Signature]</i>		X1 m/m SHEET : 1/1

**Wha Yu INDUSTRIAL CO.,LTD.**  
 譚裕實業股份有限公司  
 THIS DRAWING, AND ITS INHERANT DESIGN CONCEPTS, ARE THE PROPERTY OF WHA YU AND AS SUCH MAY NOT BE COPIED, REPRODUCED, OR GIVEN TO THIRD PARTIES WITHOUT THE WRITTEN CONSENT OF WHA YU.



# 華裕實業股份有限公司

## WHA YU INDUSTRIAL CO., LTD

### RF Antenna Assembly

P/NO : C147-510097-A SPEC : Dual Band

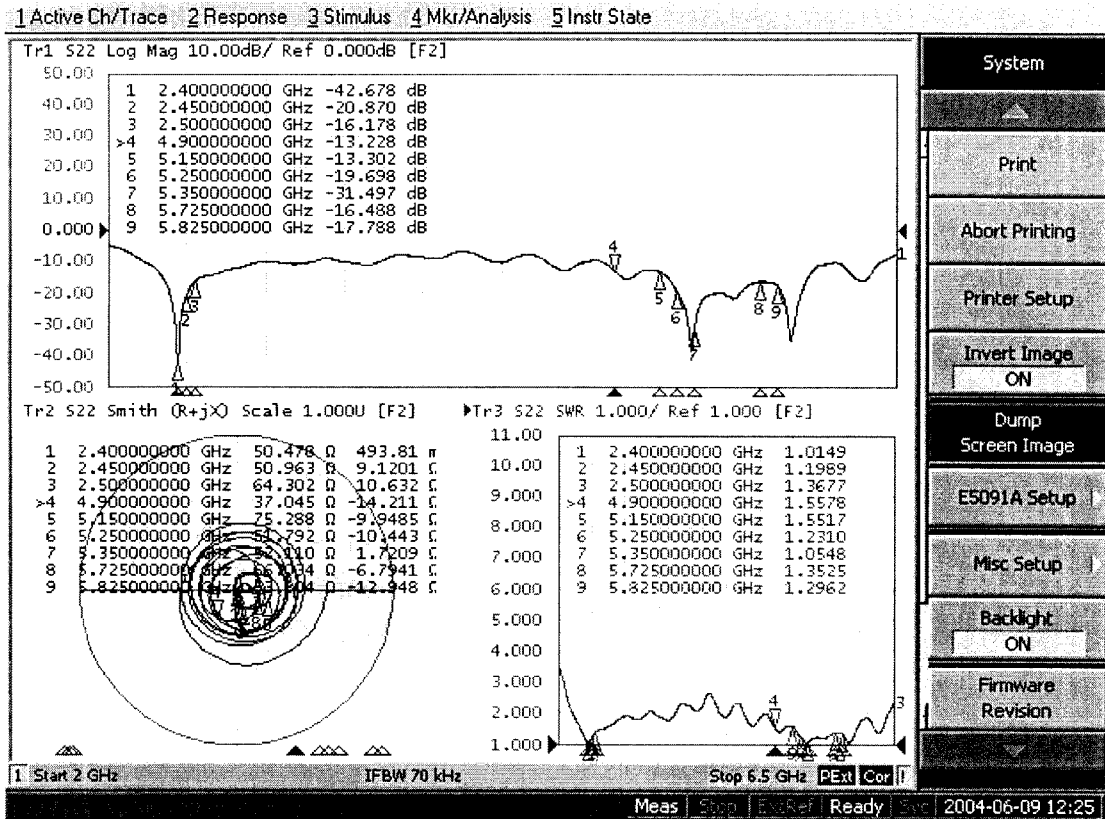

System

Print

Abort Printing

Printer Setup

Invert Image ON

Dump Screen Image

E5091A Setup

Misc Setup

Backlight ON

Firmware Revision

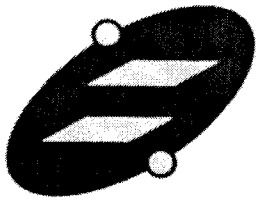

# 譚裕實業股份有限公司

## WHA YU INDUSTRIAL CO., LTD

C147-510097-A

Far-field amplitude of C147-510079-A-H.nsi

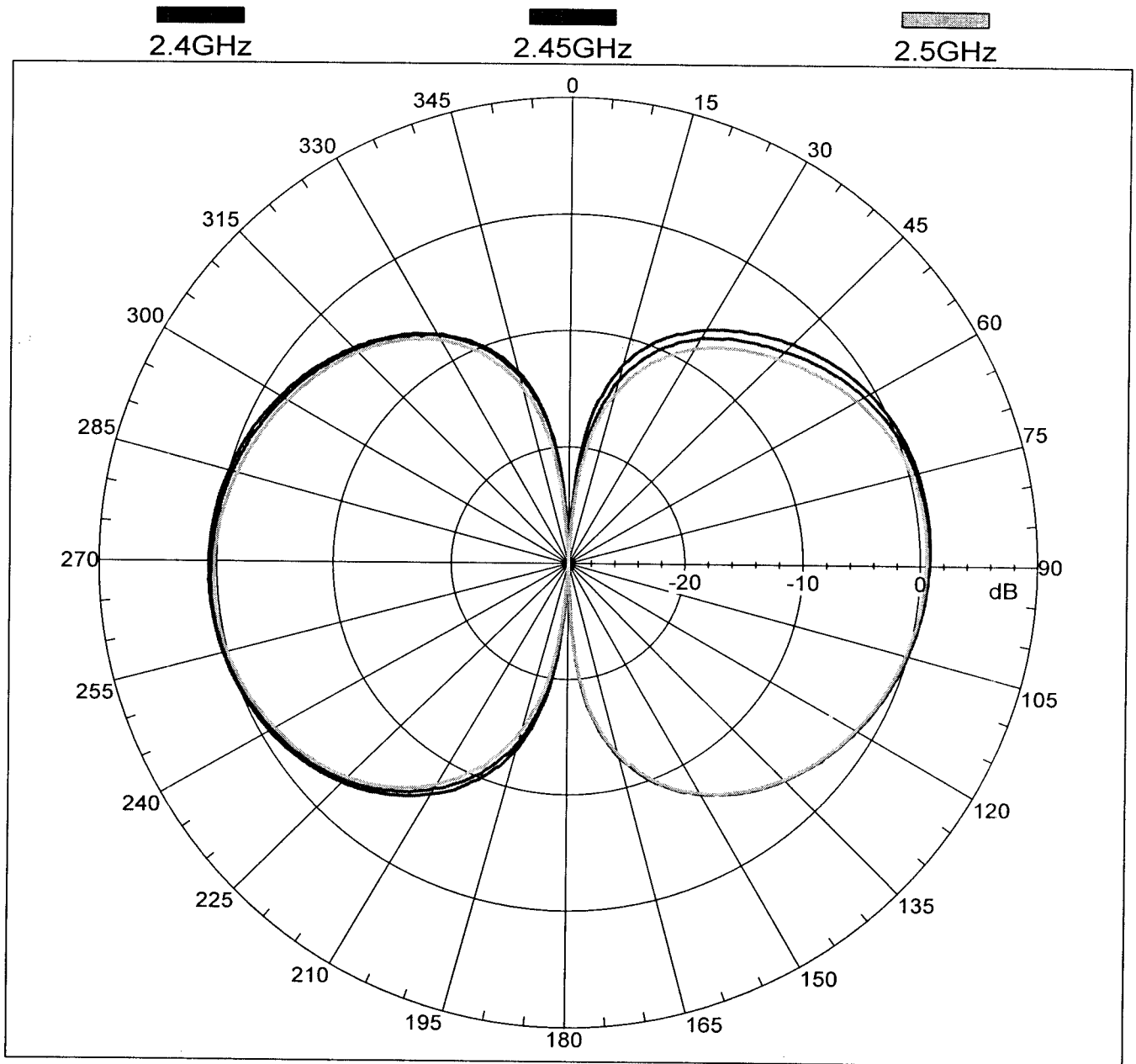

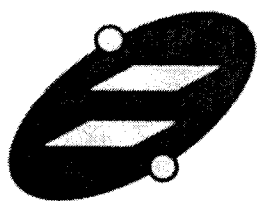

# 譚裕實業股份有限公司

## WHA YU INDUSTRIAL CO., LTD

C147-510097-A

Far-field amplitude of C147-510079-A-V01.nsi

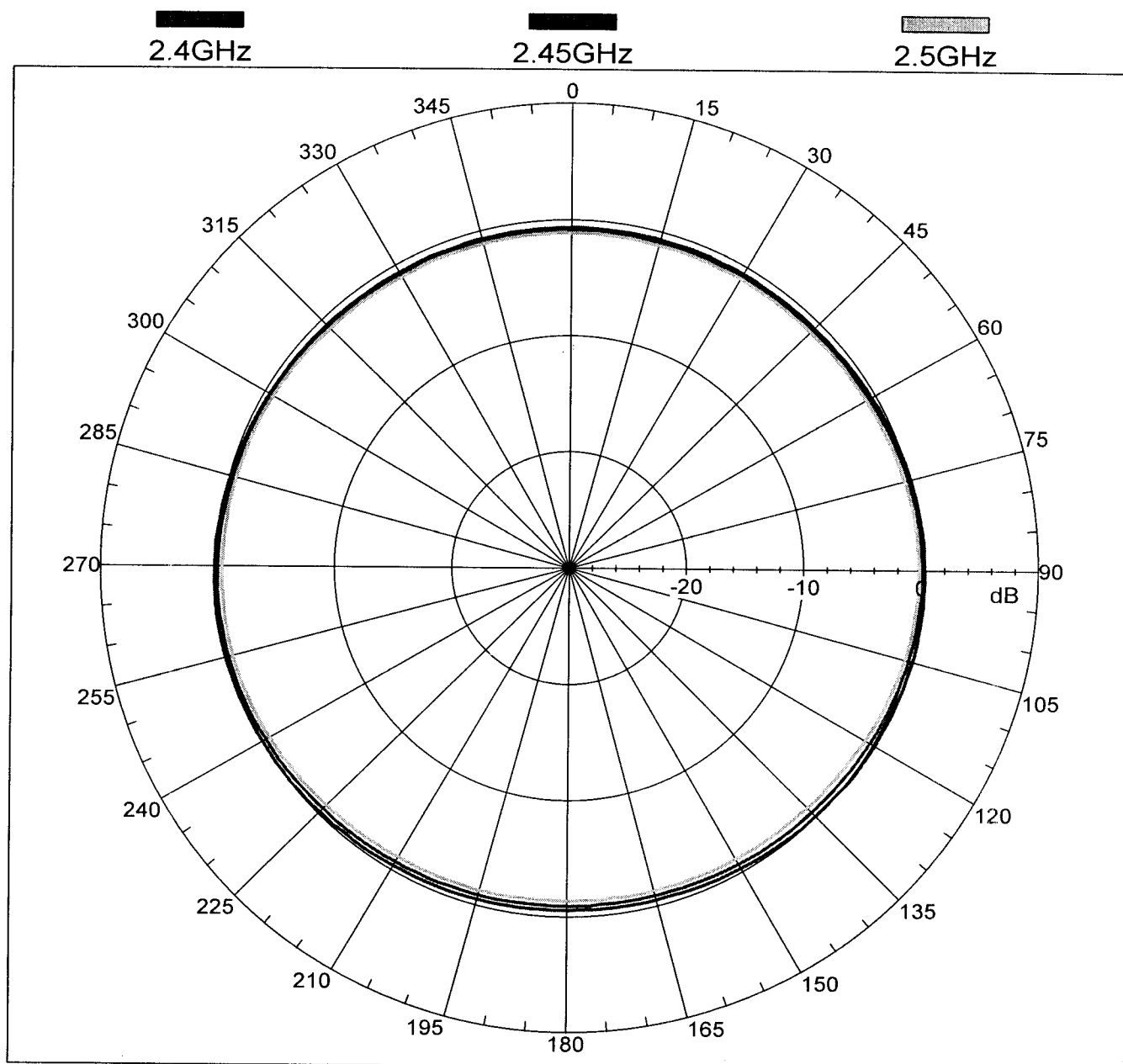

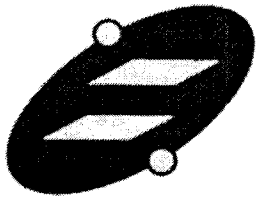

# 譚裕實業股份有限公司

## WHA YU INDUSTRIAL CO., LTD

C147-510097-A

Far-field amplitude of C147-510079-A-H.nsi

4.9GHz      5.15GHz      5.25GHz  
5.35GHz      5.725GHz      5.825GHz

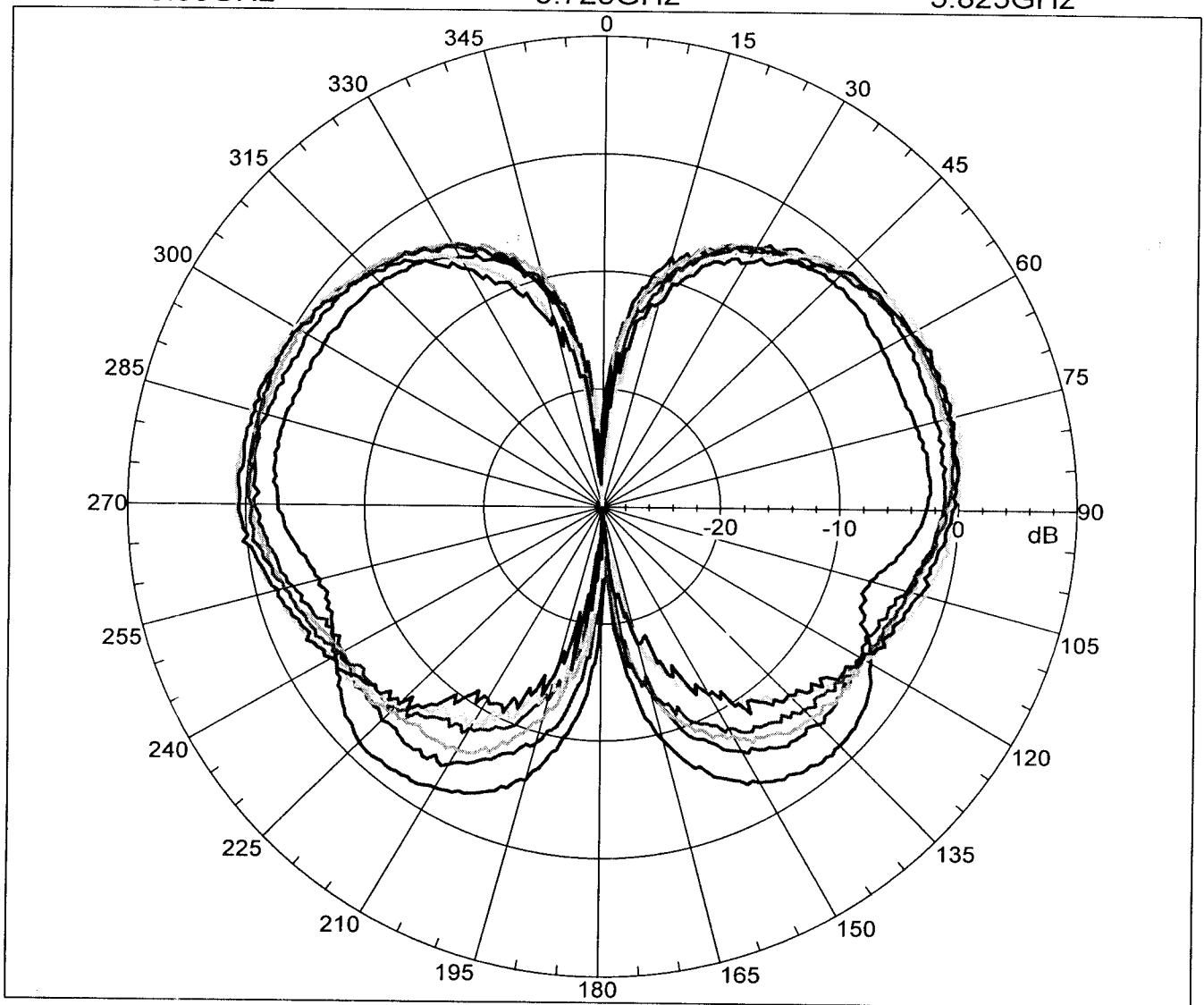



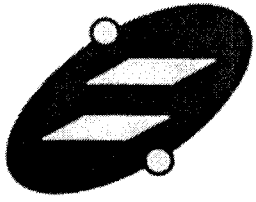

# 譚裕實業股份有限公司

## WHA YU INDUSTRIAL CO., LTD

C147-510097-A

Far-field amplitude of C147-510079-A-V01.nsi

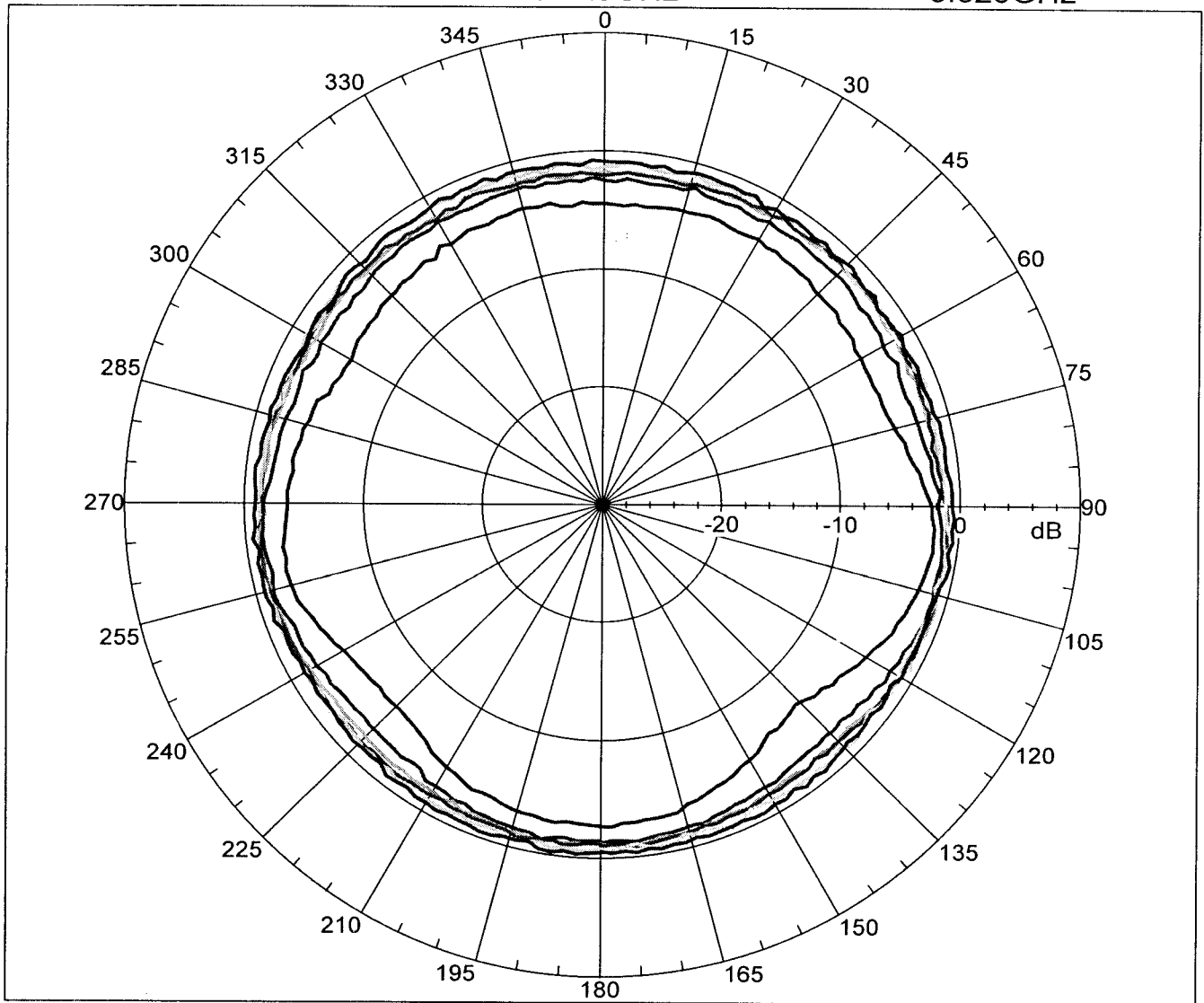
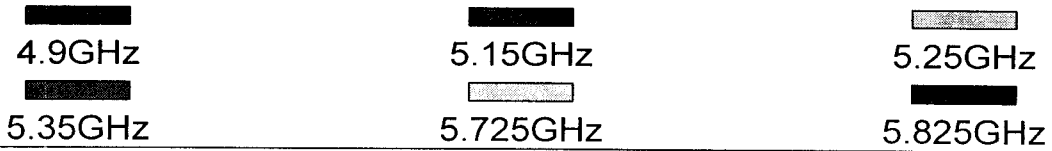

A3132PS001	FEP INSULATED HIGH-FREQUENCY COAXIAL CABLE	PAGE	1 / 2
PRODUCT STANDARD		ISSUED	21. Oct. 2003
		REVISED	

**I - Scope**

This specification presents a FEP insulated high-frequency coaxial cable AWG 32, 1.13 mm O.D. for internal wiring of electronic equipment, such as Computer / Notebook with wireless communication systems.

**II - Construction**

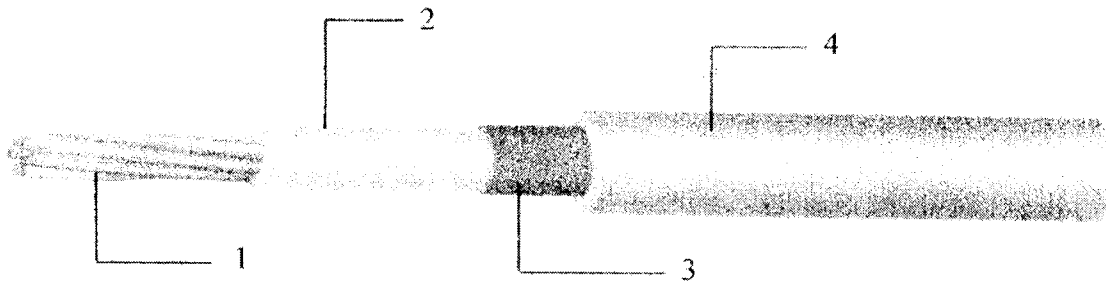

Item	Unit	Details
1. Inner Conductor	Material	Silver coated copper
	Composition	No./mm AWG 32 or 7 × 0.08
	Dia. (approx.)	mm 0.24
2. Dielectric	Material	Extruded FEP
	Thickness	mm 0.22
	Nom. O.D.	mm 0.68 ± 0.02
	Color	Natural
3. Outer Conductor	Material	Silver coated copper
	Composition	Braided (16 / 4 / 0.05)
	Dia. (approx)	mm 0.90 ± 0.03
4. Jacket	Material	Extruded FEP
	Thickness	mm 0.10
	Dia.	mm 1.13 + 0.05 / -0.08
	Color	Standard colors are Light Grey, Black, Dark Grey

Note :		MADE BY	<i>Shen Bin Chai</i>
		APPROVALS	<i>Shen Bin Chai</i>

A3132PS001	FEP INSULATED HIGH-FREQUENCY COAXIAL CABLE	PAGE	2 / 2
PRODUCT STANDARD		ISSUED	21. Oct. 2003
		REVISED	

**III – Characteristics**

Item	Unit	Specified Value	Note
Temperature Rating	°C	200	
Voltage Lasting	V	250	
Dielectric strength	—	Dielectric core: No breakdown at AC 1.5 kV for 0.15 sec.	Spark test
		Jacket: No breakdown at AC 1.5 kV for 0.15 sec.	Spark test
		No breakdown at AC 500V for 1 min.	Outer conductor to inner conductor
Inner conductor resistance	Ω / km	525	at 20°C
Insulation resistance	MΩ / km	Min. 1500	at 20°C
Characteristic Impedance	Ω	50 ± 2	TDR method
Capacitance	pF / m	98	at 1 kHz
Attenuation. (nom.)	dB / m	2.0	1.0 GHz
		2.9	2.0 GHz
		3.6	3.0 GHz
		4.2	4.0 GHz
		4.7	5.0 GHz
		5.2	6.0 GHz
Approx. Weight	g / m	3.15	

Note :

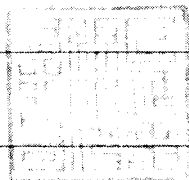

MADE BY  
APPROVALS

*Shen Bin Chao*

KURABE INDUSTRIAL CO., LTD

SP3830M-X	<p style="text-align: center;"><b>FEP INSULATED HIGH-FREQUENCY COAXIAL CABLE (FWS 5022)</b></p>	PAGE	1/4
<p style="text-align: center;"><b>PRODUCT STANDARD</b></p>		ISSUED	17-9-2001
		REVISED	

1. SCOPE

This standard covers "FEP insulated High-Frequency coaxial cable".

2. CONSTRUCTION

Construction and dimensions of the cable are shown in Figure.1 and Table 1.

3. PERFORMANCE

Performance of the finished cable is shown in Table 2. The test methods are in accordance with applicable test methods described in JIS C 3005.

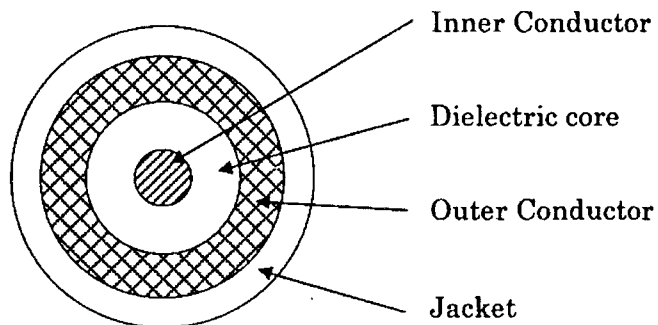

Figure 1.

NOTE :	MADE BY	<i>M. Ohba</i>
	APPROVALS	<i>T. Kawabara</i>

KURABE INDUSTRIAL CO., LTD

SP3830M-X	<b>FEP INSULATED HIGH-FREQUENCY COAXIAL CABLE (FWS 5022)</b>	PAGE	2/4
PRODUCT STANDARD		ISSUED	17-9-2001
		REVISED	

Table 1. Construction

Item	Unit	Specified Value
Inner Conductor	Material	—
	Stranding	No./mm
	Dia.(approx.)	mm
Dielectric Core	Material	—
	Thick.(nom.)	mm
	Dia.	mm
	Color	—
Outer Conductor	Material	—
	Type	—
	Dia.(approx)	mm
Jacket	Material	—
	Thick.(nom.)	mm
	Dia.	mm
	Color	—

Silver coated annealed copper wire  
7/0.08  
0.24  
FEP  
0.22  
0.68±0.05  
Natural  
Silver coated annealed copper wire  
Braid (16/4/0.05)  
0.93  
FEP  
0.10  
1.13 +0.10/-0.06  
Standard colors are  
white,black,blue,brown,and gray.

Table 2. Performance

Item	Unit	Specified Value	Note
Appearance	—	Faultless in visible	—
Inner conductor resistance	Ω/km	Max.597	at 20℃
Insulation resistance	MΩ · km	Min.1500	at 20℃
Dielectric strength	—	Dielectric core: No breakdown at AC1.5kV for 0.15sec.	Spark test
		Jacket: No breakdown at AC1.5kV for 0.15sec.	Spark test
		No breakdown at AC500V for 1min.	Outer conductor to inner conductor
Heat resistance for solder	—	Shrink or expansion of dielectric core are not more than 0.5mm	※
Capacitance	pF/m	nom. 98	at 1kHz
Characteristic impedance	Ω	50±2	TDR method
Attenuation (nom.)	dB/m	2.0	1.0GHz
		2.9	2.0GHZ
		3.6	3.0GHz
		4.2	4.0GHz
		4.7	5.0GHz
		5.2	6.0GHz

※ After immersion of dielectric core, 10mm into soldering pot which is 230℃ for 5 seconds, shrinkage or expansion of the dielectric core must not exceed 0.5mm.

NOTE :

MADE BY

*M. Ohba*

APPROVALS

*J. Kawasawa*

KURABE INDUSTRIAL CO., LTD

SP3830M-X	<b>FEP INSULATED HIGH-FREQUENCY COAXIAL CABLE (FWS 5022)</b>	PAGE	3/4
PRODUCT STANDARD		ISSUED	17-9-2001
		REVISED	
<p><b>4. INSPECTION</b></p> <p>An inspection is took place in accordance with applicable test methods. The cable has to pass the specifications described Table 1 and Table 2.</p> <p><b>5. TEST METHOD</b></p> <p>The test methods are in accordance with applicable test methods described in JIS C 3005 (Test methods for rubber or plastic insulated wires and cables).</p> <p><b>6. TEMPERATURE RATING</b></p> <p style="padding-left: 40px;">150 °C</p> <p><b>7. VOLATGE LATING</b></p> <p style="padding-left: 40px;">250 V</p> <p><b>8. MARKING ON TAG</b></p> <p>Each reel of finished cable is tagged to indicate following information:</p> <ul style="list-style-type: none"> <li>(1) Designation of the cable,</li> <li>(2) Conductor size,</li> <li>(3) Length,</li> <li>(4) Date of manufacture or LOT No.,</li> <li>(5) Specification No., and</li> <li>(6) Manufacture's name.</li> </ul> <p><b>9. PACKAGE</b></p> <p>The finished cables are cut into a shipping length of 200 meters, reeled to paper bobbin and packed securely to prevent injuries during transportation. Odd length of the finished wires should be accepted for shipping according to the condition of mutual agreement.</p> <p>In the case no agreement is found, the condition stated in quotation shall prevail.</p> <p><b>10. APPLICATION NOTES</b></p> <p>10-1. For use other than the use mutually agreed, compatibility should be carefully confirmed in each practical use by user.</p> <p>10-2. It is recommended to make a trial run for each practical application.</p>			
NOTE :		MADE BY	<i>M. Ohba</i>
		APPROVALS	<i>T. Kawasaki</i>

KURABE INDUSTRIAL CO., LTD

SP3830M-X	<b>FEP INSULATED HIGH-FREQUENCY COAXIAL CABLE (FWS 5022)</b>	PAGE	4/4
<b>PRODUCT STANDARD</b>		ISSUED	17-9-2001
		REVISED	

10-3. In case a design for use of cable is changed, please contact our sales department, if necessary. Do not use under extreme mechanical stress such as hard bending, tightening, and twisting. The use under extreme mechanical stress may cause not only shortening the life span of cable but also troubles such as decline of dielectric strength.

10-4. Handling precautions

① Do not hurt the insulation and sheath of the cable by making holes and scratches. And avoid any sharp edge when wiring so as not to injure cables.

② Avoid unnecessary excessive force to cable, such as pulling, twisting, bending or tightening.

10-5. Storage precautions

Avoid continuous exposure to sunlight.

NOTE :	MADE BY	<i>M. Ohba</i>
	APPROVALS	<i>T. Kawazawa</i>

# Arnitel

polyether esters  
polyetherester  
esters de polyether

# 天線桿套材質特性表



Units Einheiten Unites	EM400	EM460	EL550	EL630	EL740	PL380
	1.12	1.16	1.20	1.23	1.27	1.18
°C	195	185	202	212	221	197
μ m/m.k	220	160	180	140	110	150
°C	\	\	110	115	120	\
°C	130	150	180	200	200	145
°C	\	50	85	115	150	\
%	0.30	0.30	0.20	0.20	0.15	0.40
%	0.75	0.70	0.55	0.60	0.90	7.0
*	HB	HB	HB	HB	HB	HB
Mpa	55	110	220	375	900	60
Mpa	4.0	7.1	13.2	20.2	26.9	3.5
Mpa	5.4	9.0	15.7	23	22.6	5.2
Mpa	8.4	11.4	16.6	22.0	26.3	8.5
Mpa	17	21	32	40	45	16
%	700	800	600	600	360	450
kj/m <sup>2</sup>	NB	NB	NB	NB	NB	NB
kj/m <sup>2</sup>	NB	NB	NB	NB	200	NB
kj/m <sup>2</sup>	NB	NB	NB	NB	9	NB
kj/m <sup>2</sup>	NB	NB	20	4	4	NB
	38	45	55	63	74	38
MV/m	\	\	\	\	\	\
Ω.cm	5*10 <sup>14</sup>	10 <sup>14</sup>	10 <sup>14</sup>	10 <sup>14</sup>	10 <sup>12</sup>	10 <sup>12</sup>
Ω	>10 <sup>13</sup>	>10 <sup>14</sup>	>10 <sup>14</sup>	>10 <sup>14</sup>	>10 <sup>10</sup>	>10 <sup>13</sup>
\	4.1	\	\	3.8	\	4.7
\	4.0	4.4	4.0	3.4	3.3	4.4
x10 <sup>14</sup>	10	\	\	3.8	\	310
x10 <sup>14</sup>	170	350	400	350	300	350
\	800	800	600	600	600	800
\	600	600	600	800	800	600



**Arnitel**

**2.2 Product coding**

The structure of the Arnitel productcodes is illustrated with the following example:

U M 55 1 - V

**Thermoplastic elastomer type:**

- E = polyether ester; polyether = PTHF
- P = polyether ester; polyether = PEO/PPO
- U = polyester ester; (with extra urethane linkages)

**Indication of viscosity range or processing technique**

- L, M = injection moulding and extrusion
- B = blow moulding grade

Indication of hardness (Shore D)

Serial number

**Indication of additives, performance**

- H = heat-stabilized
- L = light/UV stabilized
- V = flame-retardant (not V-0)
- S = flame-retardant (V-0)

Figure 2.2: Arnitel product coding

**2.3 Product portfolio**

The Arnitel productrange is available with a hardness from 38 to 74 Shore D. The general Arnitel grades are shown in table 2.2. In order to enhance the flexibility of the portfolio a set of masterbatches (a.o. for heat, UV, etc) are on offer (refer to § 2.4).

Because of the development of these masterbatches heat stabilised Arnitel P is suggested for application areas where thermo-oxidative stability is an issue. For applications where colour and UV stability is required, the Arnitel E range is advised.

	Shore D					
	38	40	46	55	63	74
<b>Arnitel E</b>		EM400	EM460	EL550 EM550	EL630 EM630	EL740 EM740
<b>Arnitel P</b>	PL380		PL460	PL580 PM581		
<b>Arnitel U</b>				UM551 UM551-V UM552 UM552-V	UM622	

Table 2.2: Arnitel productrange for general purpose

Besides these multi-purpose grades, specialty grades can be offered for specific purposes and/or application areas. These grades are not intended for regular sales and are therefore restricted. Permission from marketing is needed before sampling is initiated.

	<b>Arnitel E</b>	<b>Arnitel P</b>	<b>Arnitel U</b>
<b>Automotive</b>			
• CVJ boots	EB460 EB463 EB464		
• Boyplugs		PL380-M0	
<b>Extrusion</b>			
• Roofing foil	EM402-L		

Table 2.3: Examples of specialty grades

**Arnitel® EL630/EM630**

**2.8.31 General:**

Arnitel is the brand name of a series polyester based thermoplastic elastomers. These polymers combine excellent processability with good elastomeric properties between -40 and 200°C. Arnitel EL630 and EM630 are excellent materials for injection moulding and extrusion applications respectively. The chemical structure of Arnitel EL630/EM630 is shown below.

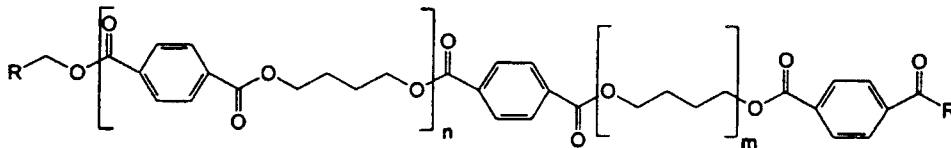

Figure 2.9: Chemical structure of Arnitel EL630/EM630.

Another way of writing the structure of Arnitels is shown below in Figure 2.



Figure 2.10: Simplified structure of Arnitel EL630/EM630 .

Arnitel EL630/EM630 is TOSCA registered (including DSL-Canada) under CAS 37282-12-5

**2.8.32 Thermal properties:**

• **Modulus-temperature behaviour:**

The materials have a glass transition at circa -40°C and a typical melting point at 213°C. The modulus-temperature behaviour is shown in graph 2.76, for comparison, accompanied by other Arnitel E types.

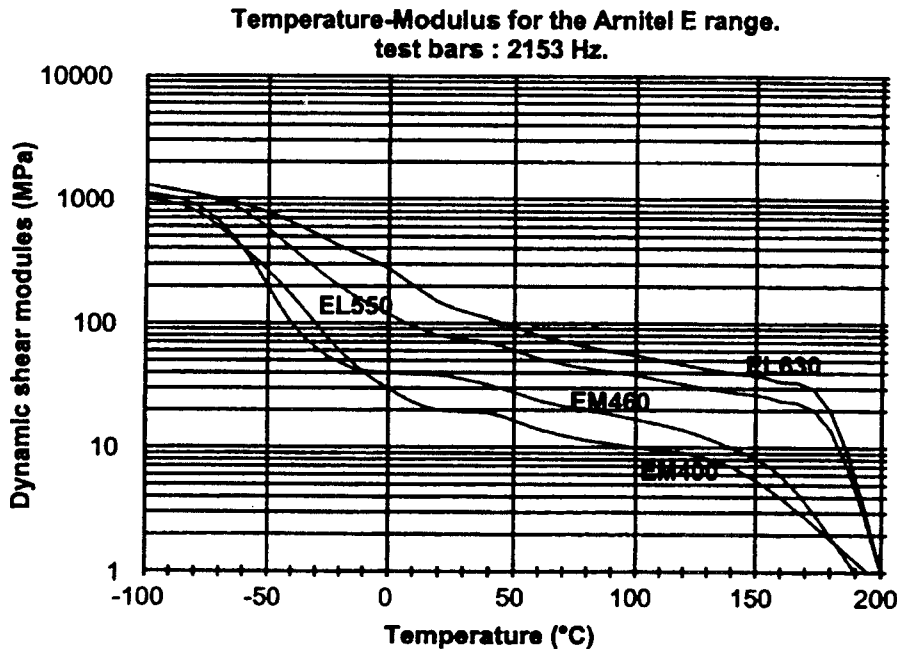

Graph 2.76: Modulus-temperature behaviour of Arnitel EL630/EM630.

**DSM Engineering Plastics**

**Arnitel® EL630/EM630**

Although information on performance at higher temperatures may be extracted from the above shown graph, a Vicat or HDT are shown in table 2.29.

analysis	SI unit	typical data	test method
Vicat A	(°C)	200	ISO 306/A
Vicat B	(°C)	125	ISO 306/B
HDT-B	(°C)	115	ISO 75-1

Table 2.29: Vicat and HDT data on Arnitel® EL630 and EM630

Arnitel EL630 and EM630 have a melting point of 213°C as found in the second heating curve of a DSC. The polymer will crystallize at 155°C using a 20°C/min cooling rate. The thermal expansion coefficient of Arnitel EL630/EM630 and is  $140 \cdot 10^{-4} \mu\text{m/m.K}$ .

• **Heat aging:**

Arnitel EL630/EM630 shows an optimum between heat resistance and colour stability. Heat aging for EL630/EM630 is under test at this moment, however the data will be between EL550 and EL740. Arrhenius curves of thermo-oxidative heat aging are shown in graph 2.77. Criterium chosen is retention of 50% original elongation at break.

**Heat aging of Arnitel E40D, 46D, 55D and 74D.**

**Natural products, Arrhenius plot.**

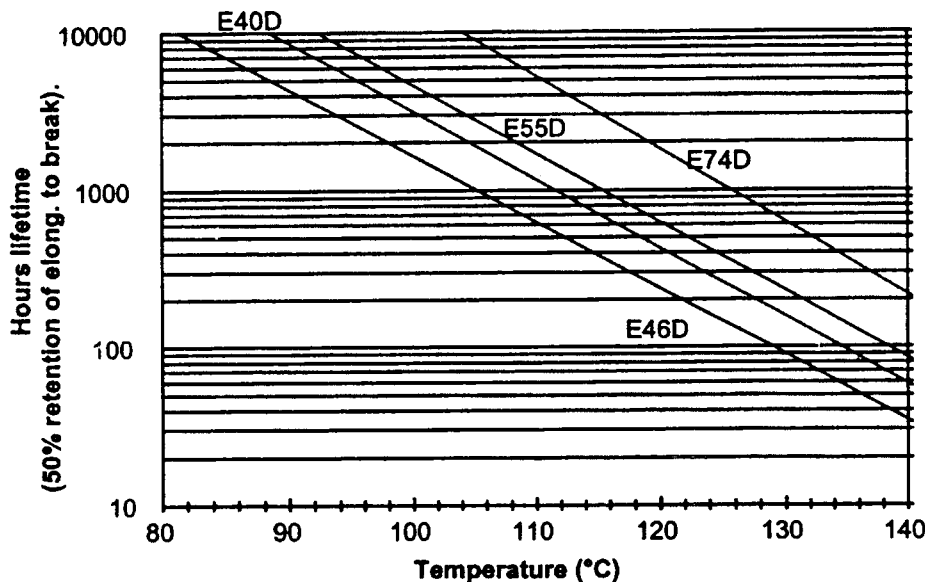

Graph 2.77: Heat stability for Arnitel E-range.

Heat ageing can be improve using a stabilisation masterbatch, however for heat stabilisation the P-range is preferred for it's excellence in performance. These data can be found in the Arnitel properties summary or an Arnitel P datasheet.

**2.8.33 Processing and Handling:**

Arnitel EL630/EM630 is a polyester with a density of  $1.12 \text{ g/cm}^3$  according ISO 1183. Due to the polyester nature of these materials it is of major importance to store the material dry prior to processing. Materials packaged in sealed packaging should have a moisture content lower then 500 ppm. The polymer will contain 0.12% moisture in 50% RH and 0.58% water after saturation in water. Both numbers are in equilibrium. If samples have become wet during storage a drying step of 24 hours  $120^\circ\text{C}$  (or 6 hours  $140^\circ\text{C}$ ) prior to use will prevent degradation of the material during processing combined with an eventual loss of properties. The air or nitrogen will have to have a dew point of at least  $-30^\circ\text{C}$ .

**Arnitel® EL630/EM630**

• **Processing:**

Arnitel EL630/EM630 shows a single melting point at 195°C in DSC. Processing conditions are shown in the table below.

polymer	zone 1	zone 2	zone 3	additional	melt	mold
EL630	225	230	235	235	225-235	20-50
EM630	225	230	235	235	235	50

All temperatures are in °C.

Table 2.30: Processing conditions for Arnitel EL630 and Arnitel EM630.

• **Rheology:**

The temperature depending melt viscosity of Arnitel EL630/EM630 and are shown below in graph 2.80 and 2.81 respectively.

**Shear rate dependent of the melt viscosity of Arnitel EL630.  
Effect of melt temperature.**

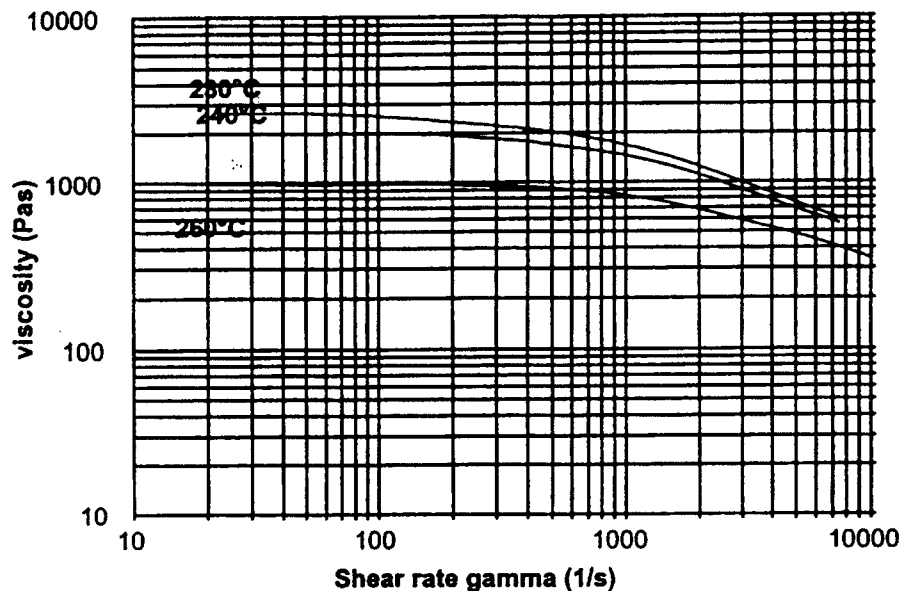

**Arnitel® EL630/EM630**

Capillar melt viscosity of Arnitel EM630.  
240, 250 and 260°C.

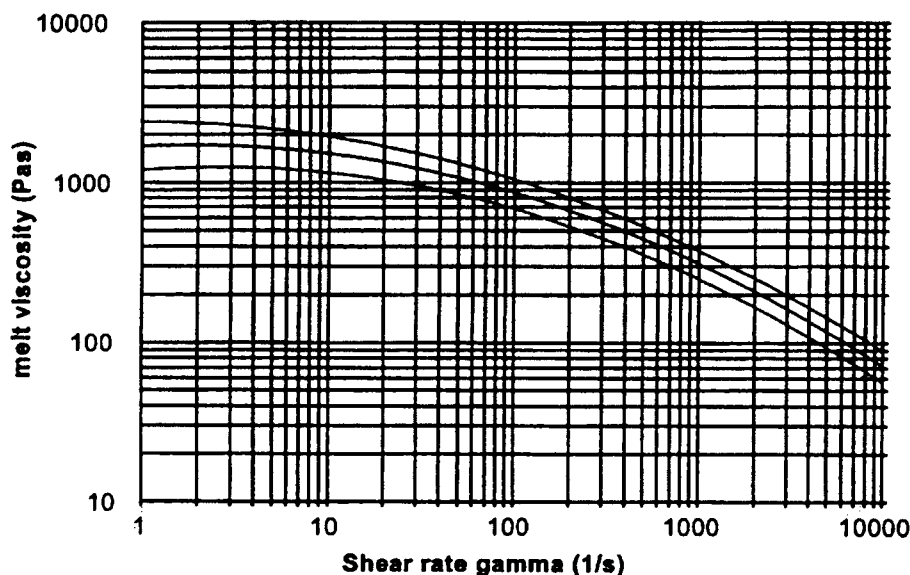

Graph 2.80 and 2.81: Temperature dependency of the melt viscosity for Arnitel EL630 and EM630 .

The MFI values are shown in table 2.31.

		EL630	EM630	
MFI 230°C	g/10 min		7	ISO 1133
MFI 240°C	g/10 min	30		ISO 1133

Table 2.31: MFI for Arnitel EL630/EM630.

• **Use of regrind:**

Arnitel can readily be recycled. If the MFI of the regrind is up or down to four points higher, 20% can be recycled. A difference of 2 MFI points allows up to 50% of regrind. Obviously the regrind should be dried properly before use.

**2.8.34 Mechanical properties:**

If Arnitel EL630 or Arnitel EM630 are processed properly the materials will have mechanical properties as shown in table 2.32.

Mechanical property	SI Unit	typica data*		test method
		EL630	EM630	
Hardness	Shore D	63	63	ISO 868
Tensile modulus (1 mm/min)	MPa	330	330	ISO 527
Tensile strength (50 mm/min)	MPa	30	30	ISO 527
Strain at break	%	350	350	ISO 527
Tensile stress at 5% strain	Mpa	11.5	11.5	
Tensile stress at 10% strain	Mpa	15.9	15.9	
Tensile stress at 50% strain	Mpa	17.3	17.3	
Tear strength Graves	KN/m	145	145	DIN53515
Izod notched 23°C (73°F)	KJ/m <sup>2</sup>	NB	NB	ISO 180/1A
Izod notched -30°C (-22°F)	KJ/m <sup>2</sup>	4	4	ISO 180/1A
Charpy notched 23°C (73°F)	KJ/m <sup>2</sup>	NB	NB	ISO 179/1eA
Charpy notched -30°C (-22°F)	KJ/m <sup>2</sup>	12	12	ISO 179/1eA

Data for dry natural materials.

\* NB: No Break

Table 2.32: mechanical properties of Arnitel® EL630.

**Amitel® EL630/EM630**

• **Abrasion:**

Amitels show good abrasion resistance in both Taber and DIN 53516 abrasion tests. Data are shown in the Amitel general property overview (also included in the EPIC)

**2.8.35 Flame retardancy:**

Amitel EL630 and EM630 show in an ISO1210/A flammability test a burning rate leading to a classification FH-1. Flame retardancy can be improved using a halogenated or halogen free FR masterbatch.

**2.8.36 Electrical properties:**

Amitel EL630/EM630 can be used for cable jacketing applications. If the material is in permanent contact with copper a copper stabilisation package should be added. If the copper wires are coated with a tin layer, no stabilisation is necessary. The electrical properties are shown in table 33.

Electrical property	SI Unit	typical data*		test method
		EL630	EM630	
Dielectric strength	KV/mm	22	22	IEC 243-1
Relative permittivity ( $\epsilon_r$ ) at 1 kHz	-	4.4	4.4	IEC 250
Dissipation factor ( $\tan \delta$ ) at 1kHz	-	0.019	0.019	IEC 250
Comparative tracking index	-	600	600	IEC 112
Volume resistivity	$10^{14} \Omega \cdot \text{cm}$	1	1	IEC 93
Surface resistivity	$10^{14} \Omega$	1	1	IEC 93

Table 2.33: Typical electrical properties of Amitel® EL630 and EM630.

**2.8.37 Chemical resistance:**

Amitel EL630 and EM630 are sensitive to strong bases and strong acids, especially at elevated temperatures. In some halogenated hydrocarbons (like tetrachloroethane), the materials (partially) dissolve. For a full review on chemical resistance of Amitel EL630 and EM630 request the chemical resistance brochure.

• **Hydrolysis**

Like all polyesters Amitel are sensitive to moisture, however Amitels are more stable to water than e.g. PET and PBT. graph 2.84 shows the hydrolytic stability of Amitel EL630 at 100°C and in steam (120°C). For improved hydrolysis stability, using a polycarbodiimid containing masterbatch like Stabaxol® in an option. To maintain all other properties use a masterbatch based on polyester. Data on the Stabaxol stabilised grade are shown in graph 2.85.



# CALIBRE 700 series

## Ignition Resistant Resins

These CALIBRE\* resins are formulated and produced to supply both clarity and enhanced ignition resistance. They do so while maintaining excellent physical properties and processability. Grades are available with additives for improved mould release and/or UV stabilisation.

CALIBRE 700: No mould release, no UV stabilisation. CALIBRE 701: Only mould release. CALIBRE 702: Only UV stabilisation. CALIBRE 703: Mould release and UV stabilisation.

### Applications

- Industrial switches
- Circuit breakers
- Plugs, sockets and switches
- Street lights
- Safety lights
- Reflectors

Properties	Test method	Value	Value
Products, Units		700-10	700-15
<b>Physical</b>			
Melt Flow Rate (300°C, 1.2kg), g/10 min.	ISO 1133	10	15
Density, kg/m <sup>3</sup>	ISO 1183	1200	1200
Mould Shrinkage, %	ASTM D-955	0.5-0.7	0.5-0.7
<b>Optical</b>			
Light Transmittance, %	ASTM D1003	84-88	84-88
<b>Thermal</b>			
HDT 0.45 MPa, annealed, °C	ISO 75	144	142
HDT 1.82 MPa, annealed, °C	ISO 75	140	139
HDT 1.82 MPa, unannealed, °C	ISO 75	123	122
Vicat Softening Point (B/50), °C	ISO 306B	149	147
<b>Mechanical</b>			
Tensile Strength at Yield, MPa	ISO 527	60	60
Tensile Strength at Rupture, MPa	ISO 527	66	66
Elongation at Yield, %	ISO 527	6	6
Elongation at Rupture, %	ISO 527	120	120
Tensile Modulus, MPa	ISO 527	2300	2300
Flexural Strength, MPa	ISO 178	100	100
Flexural Modulus, MPa	ISO 178	2400	2400
Izod Notched (23°C), J/m	ISO 180	900	850
Izod Unnotched (23°C), J/m	ISO 180	no break	no break
Charpy Notched (23°C), kJ/m <sup>2</sup>	ISO 179	30	20
<b>Flammability Rating <sup>(1)</sup></b>			
1.6 mm	UL-94	V2	V2
3.2 mm	UL-94	V0	V0
<b>Electrical</b>			
GWT 2.0 mm, 5 sec., °C	IEC 695-2-1	960	960
Ball Indentation Temperature, °C	IEC 598-1 <sup>(2)</sup>	> 125	> 125
Comp. Tracking Index (2.0 mm), V	IEC 112	250	250

(1) These numerical flame spread ratings are small scale test values and are not intended to reflect hazards presented by these or any other materials under actual fire conditions.

(2) Ball Indentation Temperature is described in IEC 598-1.

**PRODUCT SPECIFICATION**

製品規格

No. PRS-1176

**MHF series micro coaxial connector**

Qualification Test Report No. TR-1021

2	S2031	K.O	May/17/'02	K.K	Prepared by	Reviewed by	Approved by
1	S1053	K.O	Nov/14/'01	K.K	K.Ohbayashi	E,Kawabe	K.Katabuchi
0	S1025	K.O	Jun/25/'01				
REV.	ECN	BY	DATE	APP.	JUN / 25 / 01	Jun / 25 / 01	Jun / 29 / 01
REVISION RECORD							



DOCUMENT CLASSIFICATION	TITLE	No.
Product Specification 製品規格	MHF series micro coaxial connector	PRS-1176
<p>1. Scope / 序言 MHF series micro coaxial connector is a wire to board connector for AWG#36,32,30 coaxial cable . MHF series micro coaxial connector は、AWG # 36,32,30同軸ケーブルの基板対ワイヤーコネクタである。</p> <p>2. Objectives / 目的 This specification covers the requirements for product performance and test methods of MHF series microcoaxial connector 本規格は、MHF series micro coaxial connector の性能と試験条件について規定する。</p> <p>3. Part No. , construction , material and finish / 構成、材料及び仕上げ (1) Part No. Plug : 20278-***R-08,-13,-18 , Receptacle : 20279-001E-01 (2) Construction, material and finish of the connector are covered as each drawings. 構成、材料及び仕上げは、各図面に指定されている通りとする。</p> <p>4. Applicable cable / 適合ケーブル 4-1 Part No. 20278-001R-08, 20278-011R-08 (1) Description Inner conductor : AWG#36(7/0.05) Silver plating annealed copper wire or silver plating tin-copper alloy Dielectric core : Fluoro-plastics ,diameter 0.4(+0.04,-0.02)mm , nominal thickness 0.125mm Outer conductor : 8/5/0.05 , nominal diameter 0.65mm , silver plating annealed copper wire Jacket : Fluoro-plastics , diameter 0.81(+0.04,-0.02)mm , nominal thickness 0.08mm (2) Requirements Characteristic impedance : 50(+3,-3)ohm by TDR method (raise time 40ps) Nominal capacitance: 96 pF/m Conductor resistance of inner conductor at 293K (20°C) : 1400 ohm/km MAX. Insulation resistance : 1000 mega-ohm.km MIN. Dielectric withstand voltage : no breakdown at AC1000V for 1 minutes.</p> <p>(1) 構成 中心導体 : AWG # 36 (7/0.05), 銀メッキ軟銅線または銀メッキすず入り銅線 誘電体 : フッ素樹脂, 外径0.4(+0.04,-0.02), 標準厚さ0.125mm 外部導体 : 8/5/0.05, 標準外径0.65mm, 銀メッキ軟銅線 ジャケット : フッ素樹脂, 外径0.81(+0.04,-0.02)mm, 標準厚さ0.08mm</p> <p>(2) 仕様 特性インピーダンス : 50±3Ω (TDR, ライズタイム40ps) 標準静電容量 : 96pF/m 293K(20°C)時の中心導体導体抵抗 : 1400Ω /km以下 絶縁抵抗 : 1000MΩ・km以上 耐電圧 : AC1000V・1分間にて絶縁破壊の無い事</p> <p>4-2 Part No. 20278-101R-13, 20278-111R-13 (1) Description Inner conductor : AWG#32(7/0.08) Silver plating annealed copper wire or silver plating tin-copper alloy Dielectric core : Fluoro-plastics , diameter 0.68(+0.04,-0.02)mm , nominal thickness 0.22mm Outer conductor : 16/4/0.05 , nominal diameter 0.93mm , silver plating annealed copper wire Jacket : Fluoro-plastics , diameter 1.13(+0.08,-0.05)mm , nominal thickness 0.1mm</p>		

DOCUMENT CLASSIFICATION	TITLE	No.
Product Specification 製品規格	MHF series micro coaxial connector	PRS-1176
<p>(2) Requirements  Characteristic impedance : 50(+2,-2)ohm by TDR method (raise time 40ps)  Nominal capacitance: 97 pF/m  Conductor resistance of inner conductor at 293K (20°C) : 520 ohm/km MAX.  Insulation resistance : 1500 mega-ohm.km MIN.  Dielectric withstand voltage : no breakdown at AC1000V for 1 minutes.</p> <p>(1) 構成  中心導体 : AWG # 32(7/0.08),銀メッキ軟銅線または銀メッキすず入り銅線  誘電体 : フッ素樹脂,外径0.68(+0.04,-0.02),標準厚さ0.22mm  外部導体 : 16/4/0.05,標準外径0.93mm, 銀メッキ軟銅線  ジャケット : フッ素樹脂,外径1.13(+0.08,-0.05)mm, 標準厚さ0.1mm</p> <p>(2) 仕様  特性インピーダンス : 50±2Ω (TDR,ライズタイム40ps)  標準静電容量 : 97pF/m  293K(20°C)時の中心導体導体抵抗 : 520Ω /km以下  絶縁抵抗 : 1500MΩ・km以上  耐電圧 : AC1000V・1分間にて絶縁破壊の無い事</p> <p>4-3 Part No. 20278-001R-32, 20278-011R-32</p> <p>(1) Description  Inner conductor : AWG#32(7/0.08)  Silver plating annealed copper wire or silver plating tin-copper alloy  Dielectric core : Fluoro-plastics , diameter 0.66(+0.05,-0.05)mm , nominal thickness 0.21mm  First outer conductor : 16/5/0.05, tin plating annealed copper wire  Second outer conductor :16/6/0.05, nominal diameter 1.12mm , tin plating annealed copper wire  Jacket : Fluoro-plastics , diameter 1.32(+0.1,-0.1)mm , nominal thickness 0.1mm</p> <p>(2) Requirements  Characteristic impedance : 50(+2,-2)ohm by TDR method (raise time 40ps)  Nominal capacitance: 95 pF/m  Conductor resistance of inner conductor at 293K (20°C) : 520 ohm/km MAX.  Insulation resistance : 1500 mega-ohm.km MIN.  Dielectric withstand voltage : no breakdown at AC1000V for 1 minutes.</p> <p>(1) 構成  中心導体 : AWG # 32(7/0.08),銀メッキ軟銅線または銀メッキすず入り銅線  誘電体 : フッ素樹脂,外径0.66(+0.05,-0.05),標準厚さ0.21mm  外部導体(内側) : 16/5/0.05,すずメッキ軟銅線  外部導体(外側) : 16/6/0.05,標準外径1.12mm, すずメッキ軟銅線  ジャケット : フッ素樹脂,外径1.32(+0.1,-0.1)mm, 標準厚さ0.1mm</p> <p>(2) 仕様  特性インピーダンス : 50±2Ω (TDR,ライズタイム40ps)  標準静電容量 : 95pF/m  293K(20°C)時の中心導体導体抵抗 : 520Ω /km以下  絶縁抵抗 : 1500MΩ・km以上  耐電圧 : AC1000V・1分間にて絶縁破壊の無い事</p>		

DOCUMENT CLASSIFICATION	TITLE	No.
Product Specification 製品規格	MHF series micro coaxial connector	PRS-1176
<p>4-4 Part No. 20278-001R-18, 20278-011R-18 RG178 B/U</p> <p>(1) Description Inner conductor : AWG#30(7/0.102) , silver plating copper clad steel wire Dielectric core : Fluoro-plastics , diameter 0.84(+0.03,-0.03)mm , nominal thickness 0.268mm Outer conductor : 16/3/0.1 , nominal diameter 1.35mm , silver plating copper wire Jacket : Fluoro-plastics , diameter 1.8(+0.1,-0.1)mm , nominal thickness 0.23mm</p> <p>(2) Requirements Characteristic impedance : 50(+2,-2)ohm by TDR method (raise time 40ps) Nominal capacitance: 95 pF/m Conductor resistance of inner conductor at 293K (20°C) : 805 ohm/km MAX. Insulation resistance : 1500 mega-ohm.km MIN. Dielectric withstand voltage : no breakdown at AC2000V for 1 minutes.</p> <p>(1) 構成 中心導体 : AWG # 30(7/0.102),銀メッキ銅被鋼線 誘電体 : フッ素樹脂,外径0.84(±0.03),標準厚さ0.268mm 外部導体 : 16/3/0.1,標準外径1.35mm, 銀メッキ軟銅線 ジャケット : フッ素樹脂,外径1.8(±0.1)mm, 標準厚さ0.23mm</p> <p>(2) 仕様 特性インピーダンス : 50±2Ω (TDR,ライズタイム40ps) 標準静電容量 : 95pF/m 293K(20°C)時の中心導体導体抵抗 : 805Ω /km以下 絶縁抵抗 : 1500MΩ・km以上 耐電圧 : AC2000V・1分間にて絶縁破壊の無い事</p> <p>5. Ratings / 定格 (1) Rated voltage / 電圧 : AC60Vrms (2) Nominal characteristic impedance / 公称特性インピーダンス : 50Ω (3) Frequency / 周波数 : DC~3GHz (4) VSWR : 1.3 MAX. (5) Service Temperature / 使用温度範囲 : 233~363K(-40~+90°C)</p> <p>6. Test methods and performance / 試験及び性能</p> <p>6-1 Test condition / 試験条件 Unless otherwise specified, all tests and measurements shall be performed under the following conditions in accordance with MIL-STD-202 全ての測定と試験は、MIL-STD-202に基づき以下の条件で行う。 Temperature / 温度 : 288~308K (15~35°C) Humidity / 湿度 : 45~75%RH</p>		

DOCUMENT CLASSIFICATION Product Specification 製品規格	TITLE MHF series micro coaxial connector	No. PRS-1176
--	--	-----------------

## 6-2 Sample quantity / 試料数

- (1) Insulation resistance / 絶縁抵抗 : 10pcs.
- (2) Dielectric withstanding voltage / 耐電圧 : 10pcs.
- (3) VSWR : 5pcs.
- (4) Unmating force / 抜去力 : 10pcs
- (5) Durability / 耐久性 : 10pcs.
- (6) Cable retention force / ケーブル保持力 : 10pcs.
- (7) Vibration / 振動 : 10pcs.
- (8) Shock / 衝撃 : 10pcs.
- (9) Thermal shock / 温度サイクル : 10pcs.
- (10) Humidity / 湿度 : 10pcs.
- (11) Salt water spray / 塩水噴霧 : 10pcs.
- (12) Solderability / 半田付け性 : 10pcs.
- (13) Reflow soldering heat resistance / 半田耐熱性 : 10pcs.

## 6-3-1 Electrical / 電氣的性能

## (1) Contact Resistance / 接触抵抗

A. Testing: Solder the receptacle connector to the test board and mate the plug connector together, then measure the contact resistance as shown in Fig.1 by the four terminal method. Apply the low level condition in accordance with MIL-STD-202, Method 307.

Open circuit voltage : 20mV MAX

Circuit current : 10mA MAX. (DC or AC1kHz)

Contact resistance of inner contact : <resistance of A-E> - <resistance of B-E>

Contact resistance of ground contact : <resistance of A-D> - <resistance of B-D>

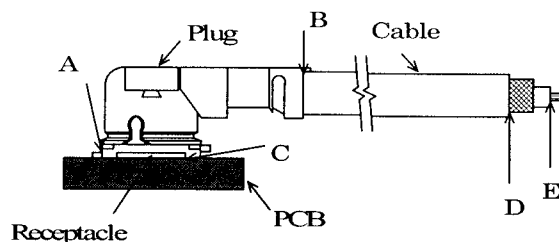

Fig.1

## B. Requirements :

Contact resistance of inner contact initial 20 milli-ohm MAX. after testing 25milli-ohm MAX.

Contact resistance of ground contact initial 10 milli-ohm MAX. after testing 15milli-ohm MAX.

A. 試験法: テスト基板にリセプタクルコネクタを半田付けし、プラグコネクタと嵌合させ、Fig. 1のように4端子法にて下記の条件で測定する。 MIL-STD-202 試験法 307 に準拠。

開回路電圧: 20mV以下

試験電流 : 10mA (DCもしくはAC1kHz)

中心導体 : <A-E間の電気抵抗> - <B-E間の電気抵抗>

外部導体 : <A-D間の電気抵抗> - <B-D間の電気抵抗>

B. 必要条件: 中心導体 初期 20mΩ 以下, 試験後 25mΩ 以下

外部導体 初期 10mΩ 以下, 試験後 15mΩ 以下

DOCUMENT CLASSIFICATION Product Specification 製品規格	TITLE MHF series micro coaxial connector	No. PRS-1176
--	--	-----------------

## (2) Insulation resistance / 絶縁抵抗

A. Testing : Mate the plug and receptacle connector together, then apply DC 100 V between the inner contact and the ground contact in accordance with MIL-STD-202, Method 302.

B.Requirements : Initial 500 Mohm MIN. after testing 100 Mohm MIN.

A.試験法: リセプタクル及びプラグコネクタを互いに嵌合させ、中心導体と外部導体の間に DC 100Vを印加し、測定する。MIL-STD-202 試験法 302 に準拠。

B.必要条件: 初期 500MΩ 以上 試験後 100MΩ 以上

## (3) Dielectric withstanding voltage / 耐電圧

A. Testing : Mate the receptacle and plug connector together, then apply AC 200 Vrms between the inner contact and the ground contact for a minute in accordance with MIL-STD-202, Method 301.

B.Requirements : No creeping discharge, flashover, nor insulator breakdown shall occur.

A.試験法: リセプタクル及びプラグコネクタを互いに嵌合させ、中心導体と外部導体の間にAC200V(実効値)を一分間印加する。MIL-STD-202 試験法 301 に準拠。

B.必要条件: 浴面放電、空中放電、絶縁破壊等の異常のないこと。

## (4) VSWR

A. Testing : Measure the VSWR as shown in Fig.3 by the network analyzer.

Frequency : 100M~3GHz

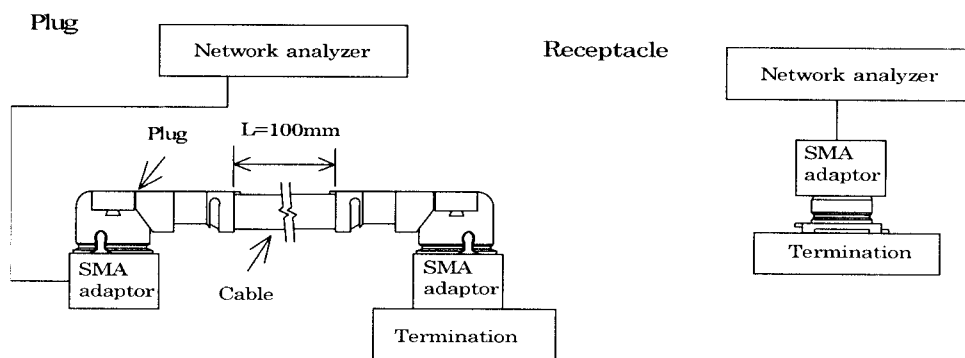

Fig.3

B.Requirements : 1.3 MAX.

A.試験法: ネットワークアナライザーにて Fig.3 のようにVSWRを測定する。

周波数 : 100M~3GHz

B.必要条件: 1.3以下

## 6-3-2 Mechanical / 機械的性能

## (1) Unmating force / 抜去力

A. Testing : Unmate the receptacle connector ( soldered to the test board) and plug at a speed  $25 \pm 3$ mm/minutes along the mating by the push-on/pull-off machine .

B.Requirements :

Total unmating force : Initial 5N MIN. after 30 cycles 3N MIN.

Unmating force of inner contact : Initial 0.15N MIN. after 30 cycles 0.1N MIN

DOCUMENT CLASSIFICATION	TITLE	No.
Product Specification 製品規格	MHF series micro coaxial connector	PRS-1176

A.試験法:挿抜試験機を用いて、基板に半田付けしたリセプタクルとプラグを嵌合軸と平行に毎分 $25 \pm 3$ mmの速度で挿抜する。

B.必要条件:

総合抜去力:初回抜去力 5N以上 ,30回後抜去力 3N以上

中心導体 :初回抜去力 0.15N以上 ,30回後抜去力 0.1N以上

(2) Durability / 耐久性

A. Testing : Mate and umate the receptacle connector ( soldered to the test board) and plug 30 cycles at a speed  $25 \pm 3$ mm/minutes along the mating by the push-on/pull-off machine .

B.Requirements :

Contact resistance of inner contact initial 20 milli-ohm MAX. after testing 25milli-ohm MAX.

Contact resistance of ground contact initial 10 milli-ohm MAX. after testing 15milli-ohm MAX.

A.試験法:挿抜試験機を用いて、基板に半田付けしたリセプタクルとプラグを嵌合軸と平行に毎分 $25 \pm 3$ mmの速度で30回挿抜する。

B.必要条件 中心導体接触抵抗 : 初期 20mΩ 以下, 試験後 25mΩ 以下

外部導体接触抵抗 : 初期 10mΩ 以下, 試験後 15mΩ 以下

(3) Cable retention force / ケーブル保持力

A. Testing : Apply force on the cable as shown in Fig.2.

During the testing, run 100mA DC to check electrical discontinuity.

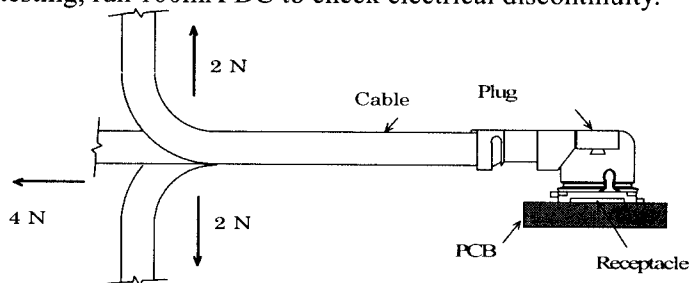

Fig.2

B.Requirements

Appearance : Looseness between the parts, chipping, breakage or other abnormality shall not occur.

Electrical discontinuity : No electrical discontinuity grater than 1 micro-sec. shall occur.

Contact resistance of inner contact initial 20 milli-ohm MAX. after testing 25milli-ohm MAX.

Contact resistance of ground contact initial 10 milli-ohm MAX. after testing 15milli-ohm MAX.

A.試験法:Fig. 2のようにケーブルに力を加える。尚、試験中にDC100mAの電流を流して電氣的瞬断を確認する。

B.必要条件 外観 : 部品のゆるみ、欠け、割れ、その他外観上の異常の無いこと。

電流瞬断 : 試験中、1 マイクロ秒を超える電氣的瞬断の無いこと。

中心導体接触抵抗 : 初期 20mΩ 以下, 試験後 25mΩ 以下

外部導体接触抵抗 : 初期 10mΩ 以下, 試験後 15mΩ 以下

DOCUMENT CLASSIFICATION	TITLE	No.
Product Specification 製品規格	MHF series micro coaxial connector	PRS-1176

## (4) Vibration / 振動

A. Testing : Apply the following vibration to the mating connector .

During the testing, run 100mA DC to check electrical discontinuity.

Frequency : 10Hz → 100Hz → 10Hz / approx 15 minutes.

Half amplitude ,Peak value of acceleration: 1.5mm or 59m/s<sup>2</sup> (6G)

Directions , cycle : 3 mutually perpendicular direction ,

5 cycles(approx 75min )about each direction

## B.Requirements

Appearance : Looseness between the parts, chipping, breakage or other abnormality shall not occur.

Electrical discontinuity : No electrical discontinuity grater than 1micro-sec. shall occur.

Contact resistance of inner contact initial 20 milli-ohm MAX. after testing 25milli-ohm MAX.

Contact resistance of ground contact initial 10 milli-ohm MAX. after testing 15milli-ohm MAX.

A.試験法: 嵌合状態のコネクタを、下記の振動を加える。尚、試験中にDC100mAの電流を流して電氣的瞬断を確認する。

周波数 : 10Hz→100Hz→10Hz / 約15分間

片振幅,加速度: 1.5mm or 59m/s<sup>2</sup> (6G)

方向,サイクル: 3つの互いに直角な方向について各5サイクル(約75分)実施

B.必要条件 外観 : 部品のゆるみ、欠け、割れ、その他外観上の異常の無いこと。

電流瞬断 : 試験中、1マイクロ秒を超える電氣的瞬断の無いこと。

中心導体接触抵抗 : 初期 20mΩ 以下、試験後 25mΩ 以下

外部導体接触抵抗 : 初期 10mΩ 以下、試験後 15mΩ 以下

## (5) Shock / 衝撃

A. Testing : Apply the following vibration to the mating connector in accordance with MIL-STD-202, Method 213, Condition B. During the testing, run 100mA DC to check electrical discontinuity.

Peak value of acceleration: 735m/s<sup>2</sup> (75G)

Duration : 11msec

Wave Form : half sinusoidal

Directions , cycle : 6 mutually perpendicular direction , 3 cycles about each direction

## B.Requirements

Appearance : Looseness between the parts, chipping, breakage or other abnormality shall not occur.

Electrical discontinuity : No electrical discontinuity grater than 1 micro-sec. shall occur.

Contact resistance of inner contact initial 20 milli-ohm MAX. after testing 25milli-ohm MAX.

Contact resistance of ground contact initial 10 milli-ohm MAX. after testing 15milli-ohm MAX.

A.試験法: 嵌合状態のコネクタを、衝撃試験機に取り付け、下記の衝撃を加える。尚、試験中にDC100mAの電流を流して電氣的瞬断を確認する。MIN-STD-202 試験法 213 試験条件 B に準拠。

最大加速度: 735m/s<sup>2</sup> (75G)

標準持続時間: 11msec.

波形: 半波正弦波

方向: 直交する6方向、各3回

B.必要条件 外観 : 部品のゆるみ、欠け、割れ、その他外観上の異常の無いこと。

電流瞬断 : 試験中、1マイクロ秒を超える電氣的瞬断の無いこと。

中心導体接触抵抗 : 初期 20mΩ 以下、試験後 25mΩ 以下

外部導体接触抵抗 : 初期 10mΩ 以下、試験後 15mΩ 以下

DOCUMENT CLASSIFICATION	TITLE	No.
Product Specification 製品規格	MHF series micro coaxial connector	PRS-1176
<p>6-3-3 Environmental / 耐環境性</p> <p>(1) Thermal shock/ 温度サイクル</p> <p>A. Testing : Apply the following environment to the mating connector .  Temperature ,duration  :233K/30minutes→278~308K/5minutes MAX.→363K/30minutes→278~308K/5minutes MAX.  (-40℃) (5~35℃) (90℃) (5~35℃)  No. of cycles : 5 cycles</p> <p>B.Requirements  Appearance : Looseness between the parts, chipping, breakage or other abnormality shall not occur.  Contact resistance of inner contact initial 20 milli-ohm MAX. after testing 25milli-ohm MAX.  Contact resistance of ground contact initial 10 milli-ohm MAX. after testing 15milli-ohm MAX.  Insulation resistance : initial 500 mega-ohm MIN. after testing 100 mega-ohm MIN.</p> <p>A.試験法:嵌合状態のコネクタを、下記の雰囲気中に放置する。  1サイクルの条件  :233K/30分→278~308K/5分以下→363K/30分→278~308K/5分以下  (-40℃) (5~35℃) (90℃) (5~35℃)  実施サイクル :5サイクル</p> <p>B.必要条件 外観 : 部品のゆるみ、欠け、割れ、その他外観上の異常の無いこと。  中心導体接触抵抗 : 初期 20mΩ 以下, 試験後 25mΩ 以下  外部導体接触抵抗 : 初期 10mΩ 以下, 試験後 15mΩ 以下  絶縁抵抗 : 初期 500MΩ 以上 試験後 100MΩ 以上</p> <p>(2) Humidity / 湿度</p> <p>A. Testing : Apply the following environment to the mating connector in accordance with MIL-STD-202,  Method 103, Condition B .  Temperature : 313±2 K (40±2℃)  Humidity : 90~95%RH  Duration : 96 hours</p> <p>B.Requirements  Appearance : Looseness between the parts, chipping, breakage or other abnormality shall not occur.  Contact resistance of inner contact initial 20 milli-ohm MAX. after testing 25milli-ohm MAX.  Contact resistance of ground contact initial 10 milli-ohm MAX. after testing 15milli-ohm MAX.  Insulation resistance : initial 500 mega-ohm MIN. after testing 100 mega-ohm MIN.</p> <p>A.試験法:嵌合状態のコネクタを、下記の雰囲気中に放置する。MIL-STD-202 試験法 103 条件 B に準拠。  温度:313±2K (40±2℃)  湿度:90~95%RH  時間:96時間</p> <p>B.必要条件 外観 : 部品のゆるみ、欠け、割れ、その他外観上の異常の無いこと。  中心導体接触抵抗 : 初期 20mΩ 以下, 試験後 25mΩ 以下  外部導体接触抵抗 : 初期 10mΩ 以下, 試験後 15mΩ 以下  絶縁抵抗 : 初期 500MΩ 以上 試験後 100MΩ 以上</p> <p>(3) Salt water spray / 塩水噴霧</p> <p>A. Testing : Apply the following environment to the mating connector in accordance with MIL-STD-202,  Method 101, Condition B.  Temperature : 308±2 K (35±2℃)  Salt water density by weight : 5±1%  Duration : 48 hours</p> <p>B.Requirements : Appearance no abnormality adversely affecting the performance shall occur.</p>		



DOCUMENT CLASSIFICATION Product Specification 製品規格	TITLE MHF series micro coaxial connector	No. PRS-1176
--	--	-----------------

A.試験法: 嵌合状態のコネクタを、下記の雰囲気中に放置する。

温度 :  $308 \pm 2\text{K}$  ( $35 \pm 2^\circ\text{C}$ )

塩水濃度:  $5 \pm 1\%$  (重量比)

時間 : 48時間

B.必要条件 : 外観 著しい腐食の無い事。

#### 6-3-4 Solder / 半田付け関連

##### (1) Solderability / 半田付け性

A. Testing : Dip the solder tine of the contact in the solder bath at  $518 \pm 5$  ( $245 \pm 5^\circ\text{C}$ ) for  $5 \pm 0.5$  sec.  
After immersing the tine in the flux of RMA or R type for 5 to 10 seconds in accordance with MIL-STD-202, Method 208.

B.Requirements : More than 95% of the dipped surface shall be evenly wet.

A.試験法: コネクタの半田付け部を $518 \pm 5\text{K}$  ( $245 \pm 5^\circ\text{C}$ )の半田槽内に $5 \pm 0.5$ 秒浸す。フラックスは、RMA  
又はR型を使用し5~10秒間浸すものとする。MIL-STD-202, 試験法208に準拠。

B.必要条件: 浸した面積の95%以上に半田がむらなく付着すること。

##### (2) Reflow soldering heat resistance / 半田耐熱性

A. Testing : Put on the receptacle connector to PCB, apply the heat 2 cycles as shown in Fig. 4

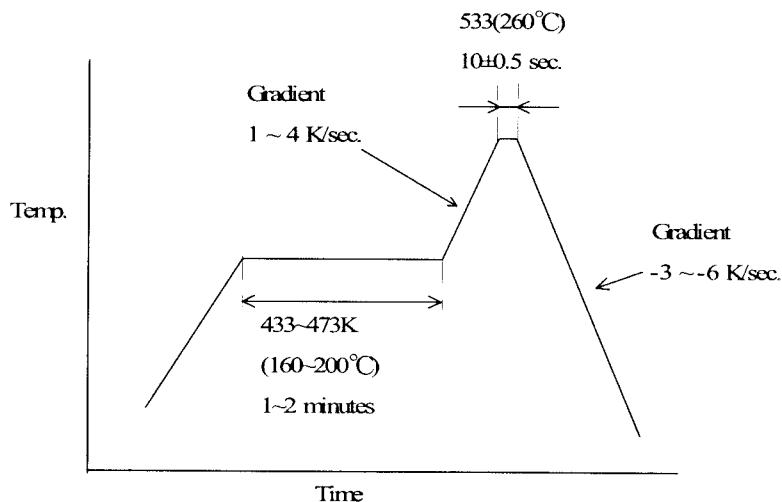

Fig.4

B.Requirements : Appearance no abnormality adversely affecting the performance shall occur.

A.試験法: 基板にリセプタクルコネクタを置き、Fig. 4の条件で2回リフローを行う。

B.必要条件: 機能を損なう変形及び欠陥の無い事。

Two-part adhesive		1590	High Super 5	EP-330 (HighSuper30)	EP-331	1500	Super
Feature		curing for 5 min type		curing for 30 min type	curing for 30min type Low-viscosity	Standard type	
Appearance	Base	Clear, blue	Translucent, blue	Translucent, pink	Clear, light yellow	Clear, light yellow	Translucent
	Hardener	Clear ight yellow	Translucent, light yellow	Translucent, milk white	Clear, light yellow	Clear, light brown	Light yellow
Viscosity (Pa · S/20°C)	Base	8	120	80	7	25	100
	Hardener	12	70	170	7	60	50
Specific gravity (g/cm <sup>2</sup> )	Base	1.17	1.17	1.17	1.16	1.16	1.14
	Hardener	1.11	1.15	1.14	1.16	0.97	0.99
Mixing ratio(Base : Hardener)		1 : 1	1 : 1	1 : 1	1 : 1	1 : 1	1 : 1
Pot life		Within 5 min	Within 5 min	Within 30 min	Within 30 min	Within 1 hr	Within 1 hr
Tensile shear strength(N/mm <sup>2</sup> )		19.0	18.0	17.5	17.6	15.7	15.1
T-Formed peeling adhesion (N/mm)		2.71	0.31	0.47		0.40	
Hardness(shore D)		77	77	82	71	82	
Coefficient of linear expansion (× 10 <sup>-5</sup> )		8.6	10.7	6.7	4.1	7.1	
Tg(°C)			47	43		53.7	
Volume resistivity(Ω · cm)			4.9 × 10 <sup>15</sup>	3.8 × 10 <sup>11</sup>	3.6 × 10 <sup>11</sup>	1.1 × 10 <sup>16</sup>	
Coefficient of water absorption(%)			2.5	2.3		0.8	
Capacity standards		Base 1 kg Hardener 1 kg	6 g set 15 g set 25 g set 80 g set	320 ml set Base 3 kg Hardener 3 kg 6 g set, 15 g set, 80 g set	Base 1 kg Hardener 1 kg	Base 500 g, 1 kg, 3 kg, 15 kg Hardener 500 g, 1 kg, 3 kg, 15 kg	15 g set 40 g set 110 g set

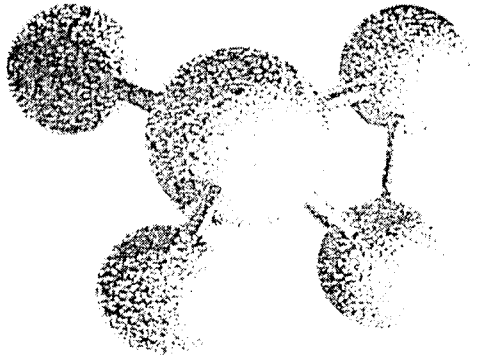

# 施敏打硬 CEMEDINE 1500

## 〔一般性質〕

	主 劑	硬 化 劑
主要成分	環氧 (Epoxy) 樹脂 的中間體黃色透明 液體	聚醯胺 (Poly- Amido) 樹脂棕 色透明液體
顏色常態		
不揮發率 (%)	99.6	99.4
黏度(9/20°C)	350	600
比重(20/20°C)	1.16	0.97
溶 劑		無
硬化劑混合比例phr		60~110
保持粘度時間	參照混合硬化劑後的粘度變化表	
膠 化 時 間	3小時	
硬化所需時間	6小時10分鐘	
可保存時間(20°C)	2年	

## 〔特性〕

由兩種液體混合而成的環氧 (Epoxy) 樹脂系黏劑，能在常溫下硬化，應用範圍至為廣泛，可穩定黏着金屬、塑膠以及其他各種物質。而由於此黏着劑，通常以聚醯胺 (Poly-Amido) 樹脂為其硬化劑，具有下列各優點：

1. 能在常溫下硬化。
2. 縱使所使用的硬化劑份量不同，也不影響其特性。
3. 由於能產生比一般黏着劑富有彎曲性的黏着層，縱使黏着不同材質的物品，也能以黏着層緩和熱膨脹的差別所引起之兩物品彎曲，對機械學的衝擊也能顯示較為良好的性能。
4. 由於能形成透明的黏着層，可以黏着透明的物質，如玻璃等等。

## 〔用 途〕

由於能強力黏着各種物質，諸如金屬，熱硬化塑膠，玻璃，飛機蒙皮以及一般電器器具等等，應用範圍至為廣泛。

縱然是複合乙烯 (Polyethylene)，聚酯 (Polyester)，天然以及人造橡膠等，以一般的黏着根本無法黏着的物質，如果加以適當的表面處理，即可強力黏着。

## 〔實 例〕

汽車、火車、船隻、飛機……，(將金屬把手黏着於玻璃窗/可以黏着附製品，三聚醯胺 (Melamine) 裝飾板等；於內部以增加強度/不同金屬間為兼防正電傷且加黏之/當作防護塗料亦可)。

電器製品……，(由於是一種優秀的黏着劑，使用於高級機器、音響機圈的黏着/電燈器或外殼的黏着/線圈圈的黏着/鐵粉芯的黏着/馬達轉體的黏着等等)。

建築……，(玻璃、壓克力門或將文字板黏於屏風黏住把手/瓷磚設備以及於位塑膠裝飾品的加黏以及組立/不銹鋼製品、鑄製建材、陶器或大理石等需要強力黏劑的物件加黏)。

高級裝飾品，玻璃以及塑膠製工藝品，精密機械……，(膠接機，調整距離儀/分光儀等等的固定)，其他諸如鐘頭，運動器材，公路標誌等等的加黏。除上述各種加黏外，也可以使用作填充劑，機械用，敷層用以及噴霧用。

時 間	25°C	15°C	5°C	0°C	黏 度	備 註
0分	350	350	350	350	100	(100%) (100%)
30分	350	350	350	350	60~100	
1小時	350	350	350	350	10~100	
15分	350	350	350	350	10~100	



圖 II 2.1  
硬化劑混合量と粘り強度  
(在20°C七天的硬化)  
試驗片：軟銅板 (25×100×1.6mm)  
(Over-lap)12.5mm



圖 II 2.2  
硬化劑混合量と粘り強度  
(在80°C一小時的硬化)  
試驗片：以及其他同圖 II 2.1

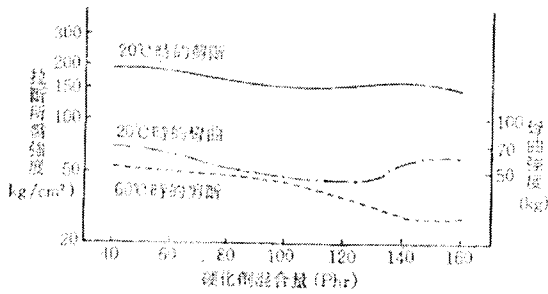

圖 II 2.3  
常溫時的硬化特性 硬化劑混合率 100phr

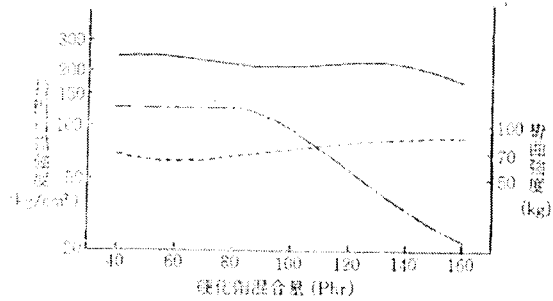

圖 II 2.5  
耐熱特性 硬化劑混合率為 100phr

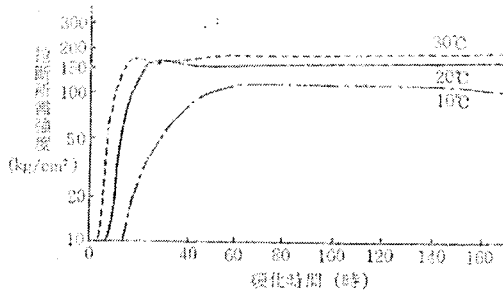

圖 II 2.4  
加熱硬化特性 硬化劑混合率為 100phr

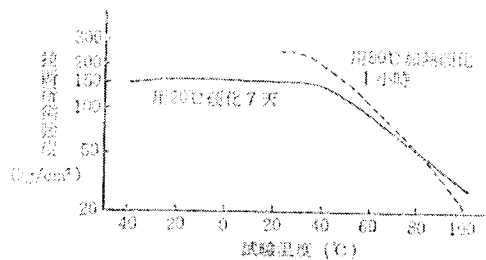

圖 II 2.6  
疲労特性

表 II 2.1 物理特性

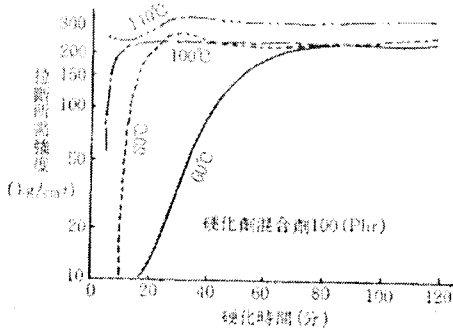
抗張力 (kg/mm <sup>2</sup> )	5.01	硬度 { ロックウェールM シャール ブローア-D	68
抗剪力 (kg/mm <sup>2</sup> )	7.40		67
彎曲彈性率 (kg/mm <sup>2</sup> )	214		82
衝擊強度 (kg/mm <sup>2</sup> )	11.6	表面固定電阻 (Ω)	5.6×10 <sup>12</sup>
除離強度 (kg/mm <sup>2</sup> )	15.10(6.41)(4)	導電率 (10 <sup>3</sup> cycle)	2.94
於變形溫度 (°C)	47	耐壓強度 (kv/mm)	19

表II 2.2 拉斷所需強度

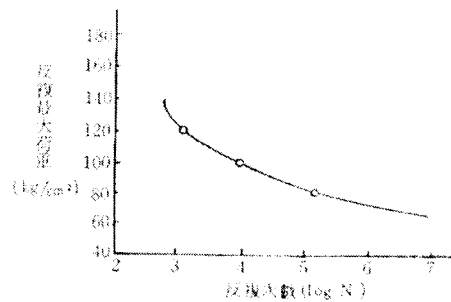
被 粘 體	拉 斷 所 需 強 度	被 粘 體	拉 斷 所 需 強 度 (20°C)
橡 樹 材	83	多 元 焦 炭	22
馬 來 西 亞 杉 材	106 ※	苯 乙 烯 樹 脂	19
針 葉 樹 材	99 ※	聚 克 力 樹 脂	30
杉 材	66	機 質 鹽 漆 樹 脂	36
鐵	158	三 聚 氫 胺 脲 樹 脂	55
錫	61	(表 面)	
黃 銅	60	三 聚 氫 胺 脲 樹 脂	45
鋼	80	(背 面)	
錳 電 鍍	71	F R P	125
鋅 電 鍍	50		

[註] 1. 粘着條件：20°C，硬化7天，硬化劑混合比 100phr(接合部over-lap)12.5mm。

2. ※記號者表示材料拉斷。

表II 2.3 促進劣化特性

試 驗	未試驗前的粘力強度 (kg/cm <sup>2</sup> )	比較調整試驗片的粘力強度(1) (1個月) (kg/cm <sup>2</sup> )	經過各試驗1個月後的粘力強度 (kg/cm <sup>2</sup> )	經過各試驗1,000小時後的粘力強度 (kg/cm <sup>2</sup> )
利用測候儀所做的耐候試驗	143	150	—	166
利用噴射測水的促進試驗	143	150	100	—
利用高溫高濕的促進試驗(2)	143	150	143	—
利用反覆冷卻的促進試驗(3)	143	150	183	—

[註] (1) 20±1°C, 65±5%RH 各保持1個月的試驗片；(2)50°C100%RH；(3)-5°C8小時~50°C16小時。

表II 2.4 耐 候 性

露 露 前 的 粘 力 強 度				拉 斷 所 需 強 度 (kg/cm <sup>2</sup> )
				147
比較調整試驗片的粘力強度 (6個月)	※	156	在戶外暴露6個月的粘力強度	147
" (1年)	※	138	" 1年 "	152
" (2年)	※	130	" 2年 "	138
" (3年)	※	123	" 3年 "	137
" (10年)	※	111	" 10年 "	130

[註] ※20±1°C, 65±5%RH 保持各期間的試驗片。

表II 2.5 耐水性 (20°C,7天硬化)

試 驗	拉 斷 所 需 強 度 (kg/cm <sup>2</sup> )			
	0	3個月	6個月	1年
常態試驗	120	106	123	120
耐水試驗		109	117	109

[註] 硬化劑混合比為 100phr  
試驗片：不銹鋼 (100×25×1.5mm)  
(接合部Over-lap)12.5mm。

表II 2.6 耐水性 (60°C,2小時硬化)

試 驗	拉 斷 所 需 強 度 (kg/cm <sup>2</sup> )			
	0	3個月	6個月	1年
常態試驗	157	150	169	163
耐水試驗		133	108	116

[註] 同表II 2.5

表II 2.7 耐油性

拉斷所需強度 (kg/cm<sup>2</sup>)

放置日數	1天	3天	5天	10天	30天	1個月
放置於20°C空溫	—	—	—	80.0	—	79.0
0°C油中	—	—	77.5	87.5	—	80.0
20°C油中	—	—	82.5	77.6	—	89.5
70°C油中	77.6	75.3	80.0	71.3	—	71.0
循環油中 cycle	—	—	79.0	78.0	89.0	76.0

放置日數	40天	2個月	3個月	6個月	1年	10年
放置於 20°C空溫	—	—	73.0	65.9	76.3	75.9
0°C油中	—	86.5	71.5	80.5	80.2	—
20°C油中	—	70.5	79.5	73.7	79.7	—
70°C油中	—	75.5	—	75.1	68.3	—
循環油中 (cycle)	71.5	—	—	—	—	—

[註] 1. 硬化劑混合比為80phr，試驗片用木片(100×25×3mm)接合部(Over-lap)12.5mm 2. 油為聚羧基油，  
3. 試驗片全部破裂。

表II 2.8 耐溶劑、耐藥品性

種 類	浸漬7天後的黏力保持率(%)		浸漬1個月後的黏力保持率(%)		
	以20°C硬化7天 的試驗片	以80°C硬化1小 時的試驗片	以20°C硬化7天 的試驗片	以80°C硬化1小 時的試驗片	
溶 劑	已 醇	107.0	80.6	91.1	78.8
		85.5	63.3	51.7	66.8
		88.8	69.5	83.4	70.8
		89.5	71.3	97.4	68.7
油	三 氯 化 矽	90.2	61.7	101.3	69.1
		91.5	72.7	65.0	69.5
油	植 物 油	102.7	90.8	107.3	90.9
	礦 油	96.2	87.8	98.1	81.2
藥 品	蒸 餾 水	93.4	72.3	95.3	69.3
	10% 稀 酸 溶 液	93.4	72.8	79.8	69.8
	10% 鹽 酸 溶 液	71.7	67.8	70.8	67.2
	10% 苛 性 鹼 溶 液	97.2	71.3	83.8	74.3
	10% 食 鹽 水 溶 液	89.6	71.8	91.0	69.9
	10% 醋 酸 溶 液	91.2	77.8	78.1	64.2

[註] 黏劑混合率=1:1，試驗片：軟鋼片(25×100×1.6mm)但是對從試驗時使用了SUS-27，接合部(Over-lap)為12.5mm。

容量規格 = (主) 110g、1kg、15kg (組)



台灣 施敏打硬 股份有限公司

總 公 司：台北縣永福工業區山頂6-3號

電 話：(02) 2629-1425、2629-1443

F A X：(02) 8631-6805

高雄分公司：高雄市民權路四二街14號

電 話：(07) 3118198、3215088

Two-part adhesive		1590	High Super 5	EP-330 (HighSuper30)	EP-331	1500	Super
Feature		curing for 5 min type		curing for 30 min type	curing for 30min type Low-viscosity	Standard type	
Appearance	Base	Clear, blue	Translucent, blue	Translucent, pink	Clear, light yellow	Clear, light yellow	Translucent
	Hardener	Clear ight yellow	Translucent, light yellow	Translucent, milk white	Clear, light yellow	Clear, light brown	Light yellow
Viscosity (Pa · S/20°C)	Base	8	120	80	7	25	100
	Hardener	12	70	170	7	60	50
Specific gravity (g/cm <sup>2</sup> )	Base	1.17	1.17	1.17	1.16	1.16	1.14
	Hardener	1.11	1.15	1.14	1.16	0.97	0.99
Mixing ratio(Base : Hardener)		1 : 1	1 : 1	1 : 1	1 : 1	1 : 1	1 : 1
Pot life		Within 5 min	Within 5 min	Within 30 min	Within 30 min	Within 1 hr	Within 1 hr
Tensile shear strength(N/mm <sup>2</sup> )		19.0	18.0	17.5	17.6	15.7	15.1
T-Formed peeling adhesion (N/mm)		2.71	0.31	0.47		0.40	
Hardness(shore D)		77	77	82	71	82	
Coefficient of linear expansion (× 10 <sup>-5</sup> )		8.6	10.7	6.7	4.1	7.1	
Tg(°C)			47	43		53.7	
Volume resistivity(Ω · cm)			4.9 × 10 <sup>15</sup>	3.8 × 10 <sup>11</sup>	3.6 × 10 <sup>11</sup>	1.1 × 10 <sup>16</sup>	
Coefficient of water absorption(%)			2.5	2.3		0.8	
Capacity standards		Base 1 kg Hardener 1 kg	6 g set 15 g set 25 g set 80 g set	320 ml set Base 3 kg Hardener 3 kg 6 g set, 15 g set, 80 g set	Base 1 kg Hardener 1 kg	Base 500 g, 1 kg, 3 kg, 15 kg Hardener 500 g, 1 kg, 3 kg, 15 kg	15 g set 40 g set 110 g set