

FCC Test Report

(Co-located)

Report No.: RFBEIH-WTW-P22120620-4 R1

FCC ID: P27-TMOG4SE

Test Model: TMO-G4SE

Received Date: 2022/12/19

Test Date: 2023/3/13

Issued Date: 2023/5/5

Applicant: Sercomm Corp.

Address: 8F, No. 3-1, YuanQu St., NanKang, Taipei 115, Taiwan, R.O.C.

Issued By: Bureau Veritas Consumer Products Services (H.K.) Ltd., Taoyuan Branch
Lin Kou Laboratories

Lab Address: No. 47-2, 14th Ling, Chia Pau Vil., Lin Kou Dist., New Taipei City, Taiwan

Test Location (1): No.19, Hwa Ya 2nd Rd., Wen Hwa Vil., Kwei Shan Dist., Taoyuan City
33383, Taiwan

Test Location (2): B2F., No.215, Sec. 3, Beixin Rd., Xindian Dist., New Taipei City 231,
Taiwan

FCC Registration / 788550 / TW0003

Designation Number: 427177 / TW0011



This report is governed by, and incorporates by reference, the Conditions of Testing as posted at the date of issuance of this report at <http://www.bureauveritas.com/home/about-us/our-business/cps/about-us/terms-conditions/> and is intended for your exclusive use. Any copying or replication of this report to or for any other person or entity, or use of our name or trademark, is permitted only with our prior written permission. This report sets forth our findings solely with respect to the test samples identified herein. The results set forth in this report are not indicative or representative of the quality or characteristics of the lot from which a test sample was taken or any similar or identical product unless specifically and expressly noted. Our report includes all of the tests requested by you and the results thereof based upon the information that you provided to us. Measurement uncertainty is only provided upon request for accredited tests. Statements of conformity are based on simple acceptance criteria without taking measurement uncertainty into account, unless otherwise requested in writing. You have 60 days from date of issuance of this report to notify us of any material error or omission caused by our negligence or if you require measurement uncertainty; provided, however, that such notice shall be in writing and shall specifically address the issue you wish to raise. A failure to raise such issue within the prescribed time shall constitute your unqualified acceptance of the completeness of this report, the tests conducted and the correctness of the report contents.

Table of Contents

Release Control Record	3
1 Certificate of Conformity	4
2 Summary of Test Results.....	5
2.1 Measurement Uncertainty.....	5
2.2 Modification Record	5
3 General Information	6
3.1 General Description of EUT	6
3.1.1 Test Mode Applicability and Tested Channel Detail	11
3.2 Description of Support Units	12
3.2.1 Configuration of System under Test	12
3.3 General Description of Applied Standards and References	14
4 Test Types and Results	15
4.1 Radiated Emission Measurement.....	15
4.1.1 Limits of Radiated Emission Measurement	15
4.1.2 Test Instruments	17
4.1.3 Test Procedures.....	18
4.1.4 Deviation from Test Standard	20
4.1.5 Test Set Up	21
4.1.6 EUT Operating Conditions.....	22
4.1.7 Test Results	22
5 Pictures of Test Arrangements.....	37
Appendix – Information of the Testing Laboratories	38

Release Control Record

Issue No.	Description	Date Issued
RFBEIH-WTW-P22120620-4	Original Release	2023/3/29
RFBEIH-WTW-P22120620-4 R1	Revise External Antenna gain	2023/5/5

1 Certificate of Conformity

Product: T-Mobile 5G Gateway

Brand: T-Mobile

Test Model: TMO-G4SE

Sample Status: Engineering Sample

Applicant: Sercomm Corp.

Test Date: 2023/3/13

Standards: 47 CFR FCC Part 15, Subpart C (Section 15.247)
47 CFR FCC Part 15, Subpart E (Section 15.407)
47 CFR FCC Part 96
FCC Part 22, Subpart H
FCC Part 24, Subpart E
FCC Part 27, Subpart C / F / H / L / M / N / O / Q
FCC Part 2
ANSI C63.10: 2013

The above equipment has been tested by **Bureau Veritas Consumer Products Services (H.K.) Ltd., Taoyuan Branch**, and found compliance with the requirement of the above standards. The test record, data evaluation & Equipment Under Test (EUT) configurations represented herein are true and accurate accounts of the measurements of the sample's RF characteristics under the conditions specified in this report.

Prepared by : Lena Wang, **Date:** 2023/5/5
Lena Wang / Specialist

Approved by : Jeremy Lin, **Date:** 2023/5/5
Jeremy Lin / Project Engineer

2 Summary of Test Results

47 CFR FCC Part 15, Subpart C (Section 15.247) 47 CFR FCC Part 15, Subpart E (Section 15.407) FCC Part 27, Subpart C / F / H / L / M / N / O / Q			
FCC Clause	Test Item	Result	Remarks
15.205 / 15.209 / 15.247(d)	Radiated Emissions and Band Edge Measurement	Pass	Meet the requirement of limit. Minimum passing margin is -3.4 dB at 2390.00 MHz.
15.407(b) (1/2/3/4(i)/10)	Radiated Emissions and Band Edge Measurement	Pass	Meet the requirement of limit. Minimum passing margin is -6.2 dB at 11490.00 MHz.
2.1053 27.53(l)	Radiated Spurious Emissions	Pass	Meet the requirement of limit. Minimum passing margin is -25.96 dB at 7680.00 MHz.

Note: Determining compliance based on the results of the compliance measurement, not taking into account measurement instrumentation uncertainty.

2.1 Measurement Uncertainty

Where relevant, the following measurement uncertainty levels have been estimated for tests performed on the EUT as specified in CISPR 16-4-2:

Measurement	Frequency	Expanded Uncertainty (k=2) (±)
Radiated Emissions up to 1 GHz	9 kHz ~ 30 MHz	2.44 dB
	30 MHz ~ 1 GHz	2.02 dB
Radiated Emissions above 1 GHz	1 GHz ~ 18 GHz	1.01 dB
	18 GHz ~ 40 GHz	1.15 dB

2.2 Modification Record

There were no modifications required for compliance.

3 General Information

3.1 General Description of EUT

Product	T-Mobile 5G Gateway			
Brand	T-Mobile			
Test Model	TMO-G4SE			
Status of EUT	Engineering Sample			
Power Supply Rating	Refer to note			
Modulation Type	WLAN	CCK, DQPSK, DBPSK for DSSS 256QAM, 64QAM, 16QAM, QPSK, BPSK for OFDM 1024QAM, 256QAM, 64QAM, 16QAM, QPSK, BPSK for OFDMA		
	BT LE	GFSK		
	LTE	QPSK, 16QAM, 64QAM, 256QAM		
	5GNR	$\pi/2$ BPSK, QPSK, 16QAM, 64QAM, 256QAM		
Operating Frequency	WLAN	2412 ~ 2462 MHz 5180 ~ 5240 MHz, 5260 ~ 5320 MHz, 5500 ~ 5720 MHz, 5745 ~ 5825 MHz		
	BT LE	2402 ~ 2480 MHz		
	LTE	LTE Band 2	Channel Bandwidth: 1.4 MHz	1850.7 ~ 1909.3 MHz
			Channel Bandwidth: 3 MHz	1851.5 ~ 1908.5 MHz
			Channel Bandwidth: 5 MHz	1852.5 ~ 1907.5 MHz
			Channel Bandwidth: 10 MHz	1855.0 ~ 1905.0 MHz
			Channel Bandwidth: 15 MHz	1857.5 ~ 1902.5 MHz
			Channel Bandwidth: 20 MHz	1860.0 ~ 1900.0 MHz
		LTE Band 4	Channel Bandwidth: 1.4 MHz	1710.7 ~ 1754.3 MHz
			Channel Bandwidth: 3 MHz	1711.5 ~ 1753.5 MHz
			Channel Bandwidth: 5 MHz	1712.5 ~ 1752.5 MHz
			Channel Bandwidth: 10 MHz	1715.0 ~ 1750.0 MHz
			Channel Bandwidth: 15 MHz	1717.5 ~ 1747.5 MHz
			Channel Bandwidth: 20 MHz	1720.0 ~ 1745.0 MHz
LTE Band 5	Channel Bandwidth: 1.4 MHz	824.7 ~ 848.3 MHz		
	Channel Bandwidth: 3 MHz	825.5 ~ 847.5 MHz		
	Channel Bandwidth: 5 MHz	826.5 ~ 846.5 MHz		
	Channel Bandwidth: 10 MHz	829 ~ 844 MHz		
LTE Band 12	Channel Bandwidth: 1.4 MHz	699.7 ~ 715.3 MHz		
	Channel Bandwidth: 3 MHz	700.5 ~ 714.5 MHz		
	Channel Bandwidth: 5 MHz	701.5 ~ 713.5 MHz		
	Channel Bandwidth: 10 MHz	704.0 ~ 711.0 MHz		

Operating Frequency	LTE	LTE Band 25	Channel Bandwidth: 1.4 MHz	1850.7 ~ 1914.3 MHz
			Channel Bandwidth: 3 MHz	1851.5 ~ 1913.5 MHz
			Channel Bandwidth: 5 MHz	1852.5 ~ 1912.5 MHz
			Channel Bandwidth: 10 MHz	1855.0 ~ 1910.0 MHz
			Channel Bandwidth: 15 MHz	1857.5 ~ 1907.5 MHz
			Channel Bandwidth: 20 MHz	1860.0 ~ 1905.0 MHz
		LTE Band 41	Channel Bandwidth: 5 MHz	2498.5 ~ 2687.5 MHz
			Channel Bandwidth: 10 MHz	2501.0 ~ 2685.0 MHz
			Channel Bandwidth: 15 MHz	2503.5 ~ 2682.5 MHz
			Channel Bandwidth: 20 MHz	2506.0 ~ 2680.0 MHz
		LTE Band 48	Channel Bandwidth: 5 MHz	3552.5 ~ 3647.5MHz
			Channel Bandwidth: 10 MHz	3555.0 ~ 3645.0MHz
			Channel Bandwidth: 15 MHz	3557.5 ~ 3642.5MHz
		LTE Band 66	Channel Bandwidth: 20 MHz	3560.0 ~ 3640.0MHz
			Channel Bandwidth: 1.4 MHz	1710.7 ~ 1779.3 MHz
			Channel Bandwidth: 3 MHz	1711.5 ~ 1778.5 MHz
			Channel Bandwidth: 5 MHz	1712.5 ~ 1777.5 MHz
			Channel Bandwidth: 10 MHz	1715.0 ~ 1775.0 MHz
			Channel Bandwidth: 15 MHz	1717.5 ~ 1772.5 MHz
		LTE Band 71	Channel Bandwidth: 20 MHz	1720.0 ~ 1770.0 MHz
			Channel Bandwidth: 5 MHz	665.5 ~ 695.5 MHz
	Channel Bandwidth: 10 MHz		668.0 ~ 693.0 MHz	
	Channel Bandwidth: 15 MHz		670.5 ~ 690.5 MHz	
	5GNR	n25	Channel Bandwidth: 20 MHz	673.0 ~ 688.0 MHz
			Channel Bandwidth: 5 MHz	1852.5 ~ 1912.5MHz
			Channel Bandwidth: 10 MHz	1855.0 ~ 1910.0MHz
			Channel Bandwidth: 15 MHz	1857.5 ~ 1907.5MHz
			Channel Bandwidth: 20 MHz	1860.0 ~ 1905.0MHz
			Channel Bandwidth: 25 MHz	1862.5 ~ 1902.5MHz
			Channel Bandwidth: 30 MHz	1865.0 ~ 1900.0MHz
		n41	Channel Bandwidth: 40 MHz	1870.0 ~ 1895.0MHz
			Channel Bandwidth 10MHz	2501.01 ~ 2685.00MHz
			Channel Bandwidth 15MHz	2503.50 ~ 2682.48MHz
Channel Bandwidth 20MHz			2506.02 ~ 2679.99MHz	
Channel Bandwidth 30MHz			2511.00 ~ 2674.98MHz	
Channel Bandwidth 40MHz			2516.01 ~ 2670.00MHz	
Channel Bandwidth 50MHz			2521.02 ~ 2664.99MHz	
Channel Bandwidth 60MHz			2526.00 ~ 2659.98MHz	
Channel Bandwidth 70MHz			2531.01 ~ 2655.00MHz	
Channel Bandwidth 80MHz			2536.02 ~ 2649.99MHz	
Channel Bandwidth 90MHz			2541.00 ~ 2644.98MHz	
Channel Bandwidth 100MHz			2546.01 ~ 2640.00MHz	

Operating Frequency	5GNR	n48	Channel Bandwidth 10MHz	3555.00 ~ 3694.98MHz
			Channel Bandwidth 15MHz	3557.52 ~ 3692.49MHz
			Channel Bandwidth 20MHz	3560.01 ~ 3690.00MHz
			Channel Bandwidth 30MHz	3565.02 ~ 3684.99MHz
			Channel Bandwidth 40MHz	3570.00 ~ 3679.98MHz
			Channel Bandwidth 50MHz	3575.01 ~ 3675.00MHz
			Channel Bandwidth 60MHz	3580.02 ~ 3669.99MHz
			Channel Bandwidth 70MHz	3585.00 ~ 3664.98MHz
			Channel Bandwidth 80MHz	3590.01 ~ 3660.00MHz
			Channel Bandwidth 90MHz	3595.02 ~ 3654.99MHz
			Channel Bandwidth 100MHz	3600.00 ~ 3649.98MHz
		n66	Channel Bandwidth 5MHz	1712.5 ~ 1777.5MHz
			Channel Bandwidth 10MHz	1715.0 ~ 1775.0MHz
			Channel Bandwidth 15MHz	1717.5 ~ 1772.5MHz
			Channel Bandwidth 20MHz	1720.0 ~ 1770.0MHz
			Channel Bandwidth 25MHz	1722.5 ~ 1767.5MHz
			Channel Bandwidth 30MHz	1725.0 ~ 1765.0MHz
			Channel Bandwidth 40MHz	1730.0~ 1760.0MHz
		n71	Channel Bandwidth 5MHz	665.5 ~ 695.5MHz
			Channel Bandwidth 10MHz	668.0 ~ 693.0MHz
			Channel Bandwidth 15MHz	670.5 ~ 690.5MHz
			Channel Bandwidth 20MHz	673.0 ~ 688.0MHz
		n77 (Part 27O)	Channel Bandwidth 10MHz	3705.00 ~3975.00MHz
			Channel Bandwidth 15MHz	3707.52 ~3972.48MHz
			Channel Bandwidth 20MHz	3710.01 ~3969.99MHz
			Channel Bandwidth 30MHz	3715.02 ~3965.00MHz
			Channel Bandwidth 40MHz	3720.00 ~ 3960.00MHz
			Channel Bandwidth 50MHz	3725.01~ 3954.99MHz
			Channel Bandwidth 60MHz	3730.02 ~ 3949.98MHz
			Channel Bandwidth 70MHz	3735.00 ~3945.00MHz
			Channel Bandwidth 80MHz	3740.01 ~ 3939.99MHz
			Channel Bandwidth 90MHz	3745.02~ 3934.98MHz
			Channel Bandwidth 100MHz	3750.00 ~ 3930.00MHz
		n77 (Part 27Q)	Channel Bandwidth 10MHz	3455.01 ~3544.96MHz
			Channel Bandwidth 15MHz	3457.50 ~3542.49MHz
			Channel Bandwidth 20MHz	3460.02 ~3540.00MHz
			Channel Bandwidth 30MHz	3465.00 ~3534.99MHz
			Channel Bandwidth 40MHz	3470.01 ~3529.98MHz
			Channel Bandwidth 50MHz	3475.02 ~3525.00MHz
			Channel Bandwidth 60MHz	3480.00 ~3519.99MHz
			Channel Bandwidth 70MHz	3485.01 ~3514.96MHz
			Channel Bandwidth 80MHz	3490.02 ~3510.00MHz
			Channel Bandwidth 90MHz	3495.00 ~3504.99MHz
			Channel Bandwidth 100MHz	3500.01MHz
		Antenna Type	Refer to Note as below	

Antenna Connector	Refer to Note as below
Accessory Device	Refer to Note as below
Data Cable Supplied	N/A

Note:

1. The EUT contains following accessory devices.

Product	Brand	Model	Description
Adapter 1	Lucent	1A78	I/P: 100-240 Vac, 50/60 Hz, 1.2 A O/P: 5 Vdc, 3 A, 15W / 9 Vdc, 3 A, 27W / 12 Vdc, 3 A, 36W / 15 Vdc, 3 A, 45W / 20 Vdc, 2.25 A, 45W DC Output Cable: 1.8m, non-shielded
Adapter 2	MOSO	MS-V3000R150-038B0-US	I/P: 100-240 Vac, 50/60 Hz, 1.3 A O/P: 5 Vdc, 3 A / 9 Vdc, 3 A / 12 Vdc, 3 A / 15 Vdc, 3 A DC Output Cable: 1.8m, non-shielded

2. The antenna information is listed as below.

BT/WLAN Antenna

Gain (dBi)		Antenna Type	Connector Type
BT			
2400~2483.5 MHz			
1.7		Dipole	I-pex

RF Chain NO.	Gain (dBi)		Antenna Type	Connector Type
	WLAN			
	2400~2483.5 MHz	5150 MHz ~ 5850 MHz		
0	3.8	3.9	Dipole	I-pex
1	2.7	2.1	PIFA	I-pex
2	2.6	3.6	Dipole	I-pex
3	3.3	2.5	PIFA	I-pex

WWAN Antenna

Internal Antenna

Ant No.	Type	Connector	Gain (dBi)								
			LTE B2	LTE B4	LTE B5	LTE B12	LTE B25	LTE B41	LTE B48	LTE B66	LTE B71
Omni Ant 0	PIFA	I-pex	-	-	2.2	1.4	-	-	-	-	1.3
Omni Ant 1	PIFA	NA	-	-	-	-	-	2.4	-	-	-
Omni Ant 2	PIFA	NA	2.2	1.8	-	-	2.2	2.9	2.3	1.8	-
Dir Ant 2	Dipole	I-pex	3.0	2.7	-	-	3.0	4.5	4.4	2.7	-
Omni Ant 3	PIFA	NA	-	-	-	-	-	2.3	-	-	-
Omni Ant 4	PIFA	NA	2.1	1.8	-	-	2.1	2.7	2.5	1.8	-
Dir Ant 4	Dipole	I-pex	2.0	2.3	-	-	2.0	4.5	4.7	2.3	-
Omni Ant 5	Dipole	I-pex	-	-	-	-	-	-	2.0	-	-
Omni Ant 6	Dipole	I-pex	-	-	-	-	-	-	2.0	-	-

Ant No.	Type	Connector	Gain (dBi)					
			n25	n41	n48	n66	n71	n77
Omni Ant 0	PIFA	I-pex	-	-	-	-	-	-
Omni Ant 1	PIFA	NA	-	-	-	-	-	-
Omni Ant 2	PIFA	NA	-	-	-	-	-	2.6
Dir Ant 2	Dipole	I-pex	-	-	-	-	-	4.6
Omni Ant 3	PIFA	NA	-	-	-	-	-	-
Omni Ant 4	PIFA	NA	-	-	-	-	-	2.6
Dir Ant 4	Dipole	I-pex	-	-	-	-	-	4.7
Omni Ant 5	Dipole	I-pex	-	-	2.0	-	-	2.1
Omni Ant 6	Dipole	I-pex	-	-	2.0	-	-	2.2

External Antenna

Ant No.	Type	Connector	Gain (dBi)									
			n71	LTE Band 12	LTE Band 5	n66	LTE Band4	LTE Band 2	n25	n41	n77	LTE Band 48
1	Monopole.	SMA(M) ST	0.77	1.19	-0.98	4.42	4.42	4.03	4.03	3.93	3.15	2.64
2		SMA(M) ST	1.55	1.35	-1.85	3.65	3.65	3.47	3.47	3.81	2.81	2.32
3		SMA(M) ST	1.90	0.83	1.45	4.59	4.59	4.59	4.59	2.88	3.82	1.68
4		SMA(M) ST	1.37	0.84	-1.65	3.83	3.83	3.61	3.61	3.99	2.88	2.42

- * Detail antenna specification please refer to antenna datasheet and/or antenna measurement report.
- The above EUT information is declared by manufacturer and for more detailed features description, please refers to the manufacturer's specifications or user's manual.
 - After pre-test, Part 27 5GNR n77 was the worst for the final tests.
 - The EUT contains certified WWAN module with FCC ID: GKRRMLN1T.

3.1.1 Test Mode Applicability and Tested Channel Detail

EUT Configure Mode	Applicable To		Description
	RE \geq 1G	RE $<$ 1G	
A	√	√	Internal Antenna
B	√	√	External Antenna

Where **RE \geq 1G**: Radiated Emission above 1 GHz **RE $<$ 1G**: Radiated Emission below 1 GHz

Note:

1. The EUT had been pre-tested on the positioned of each 3 axis. The worst case was found when positioned on **X-plane**.
2. “-” means no effect.

Radiated Emission Test

Pre-Scan has been conducted to determine the worst-case mode from all possible combinations between available modulations, data rates, and antenna ports. The worst case was found as following channel(s) was (were) selected for the final test as listed below:

Radiated Emission above 1GHz						
EUT Config. Mode	Function	Mode	Frequency (MHz)	Available Channel	Tested Channel	Tested Mode
A, B	BT LE	BT-LE 1M	2402 ~2480	0, 19, 39	0	802.11g (Ch 6) + 802.11a (Ch 149) + BT LE (Ch 0) + 5GNR n77 (Ch 656000)
	WLAN 2.4GHz	802.11g	2412 ~ 2462	1 to 11	6	
	WLAN 5GHz	802.11a	5180 ~ 5240	36 to 48	149	
			5260 ~ 5320	52 to 64		
		5500 ~ 5700	100 to 144			
		5745 ~ 5825	149 to 165			
	5GNR	n77	3300 – 4200	650000 to 6620000	656000	

Radiated Emission below 1GHz						
EUT Config. Mode	Function	Mode	Frequency (MHz)	Available Channel	Tested Channel	Tested Mode
A, B	BT LE	BT-LE 1M	2402 ~2480	0, 19, 39	0	802.11g (Ch 6) + 802.11a (Ch 149) + BT LE (Ch 0) + 5GNR n77 (Ch 656000)
	WLAN 2.4GHz	802.11g	2412 ~ 2462	1 to 11	6	
	WLAN 5GHz	802.11a	5180 ~ 5240	36 to 48	149	
			5260 ~ 5320	52 to 64		
		5500 ~ 5700	100 to 144			
		5745 ~ 5825	149 to 165			
	5GNR	n77	3300 – 4200	650000 to 6620000	656000	

Test Condition:

Test Item	Environmental Conditions	Input Power	Tested By
Radiated Emission	25 deg. C, 61 % RH	120 Vac, 60 Hz	Karl Lee

3.2 Description of Support Units

The EUT has been tested as an independent unit together with other necessary accessories or support units. The following support units or accessories were used to form a representative test configuration during the tests.

ID	Product	Brand	Model No.	Serial No.	FCC ID	Remarks
A	Notebook	Dell	Latitude 5420	1XDRM A01	N/A	Provided by Lab
B	USB Flash	SanDisk	SDDDC3-032G	N/A	N/A	Provided by Lab
C	Notebook	Lenovo	TP00048A	TP00048A	N/A	Provided by Lab
D	Radio Communication Analyzer	Anritsu	MT8821C	6201462755	N/A	Provided by Lab

ID	Cable Descriptions	Qty.	Length (m)	Shielding (Yes/No)	Cores (Qty.)	Remarks
1	RJ-45 Cable	1	1.5	No	0	Provided by Lab
2	RJ-45 Cable	1	10	No	0	Provided by Lab

3.2.1 Configuration of System under Test

Mode A

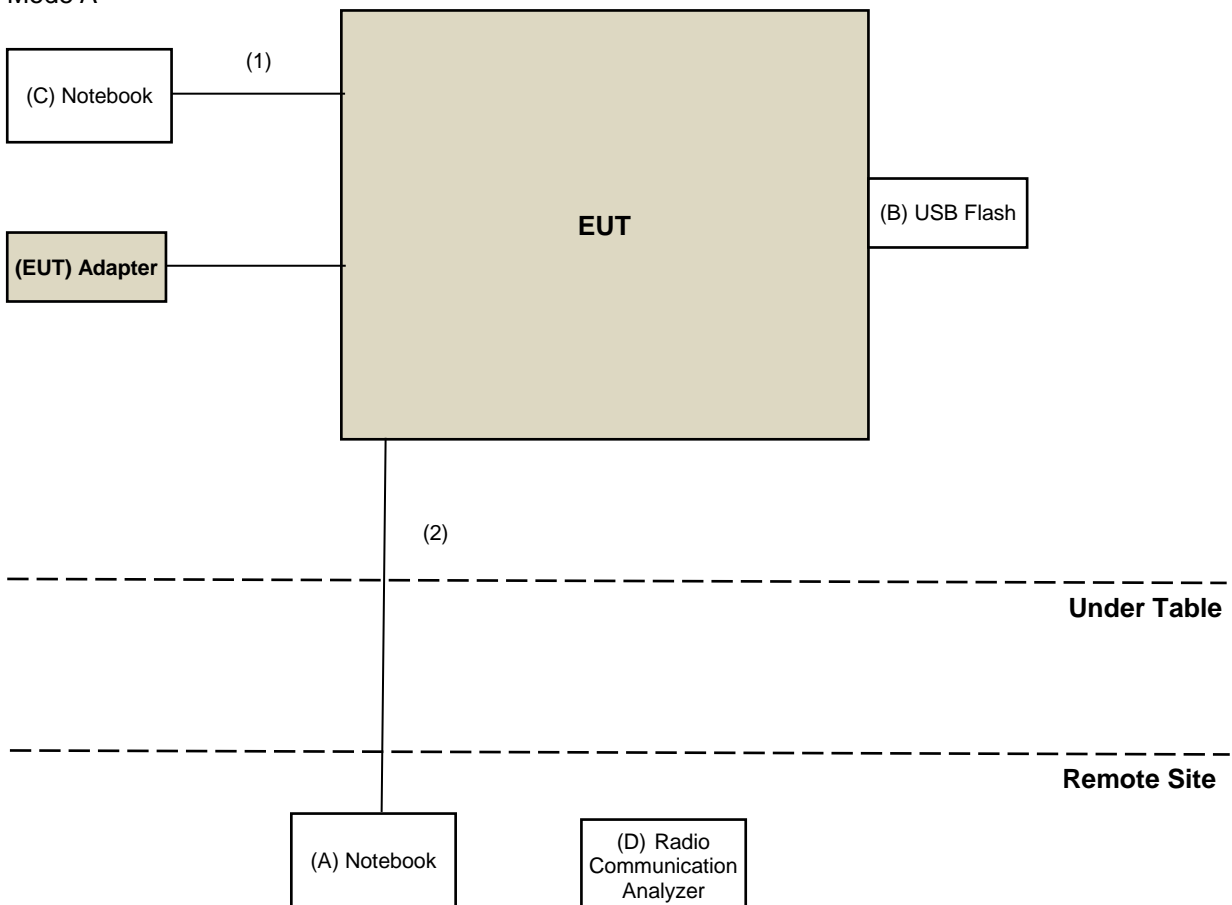

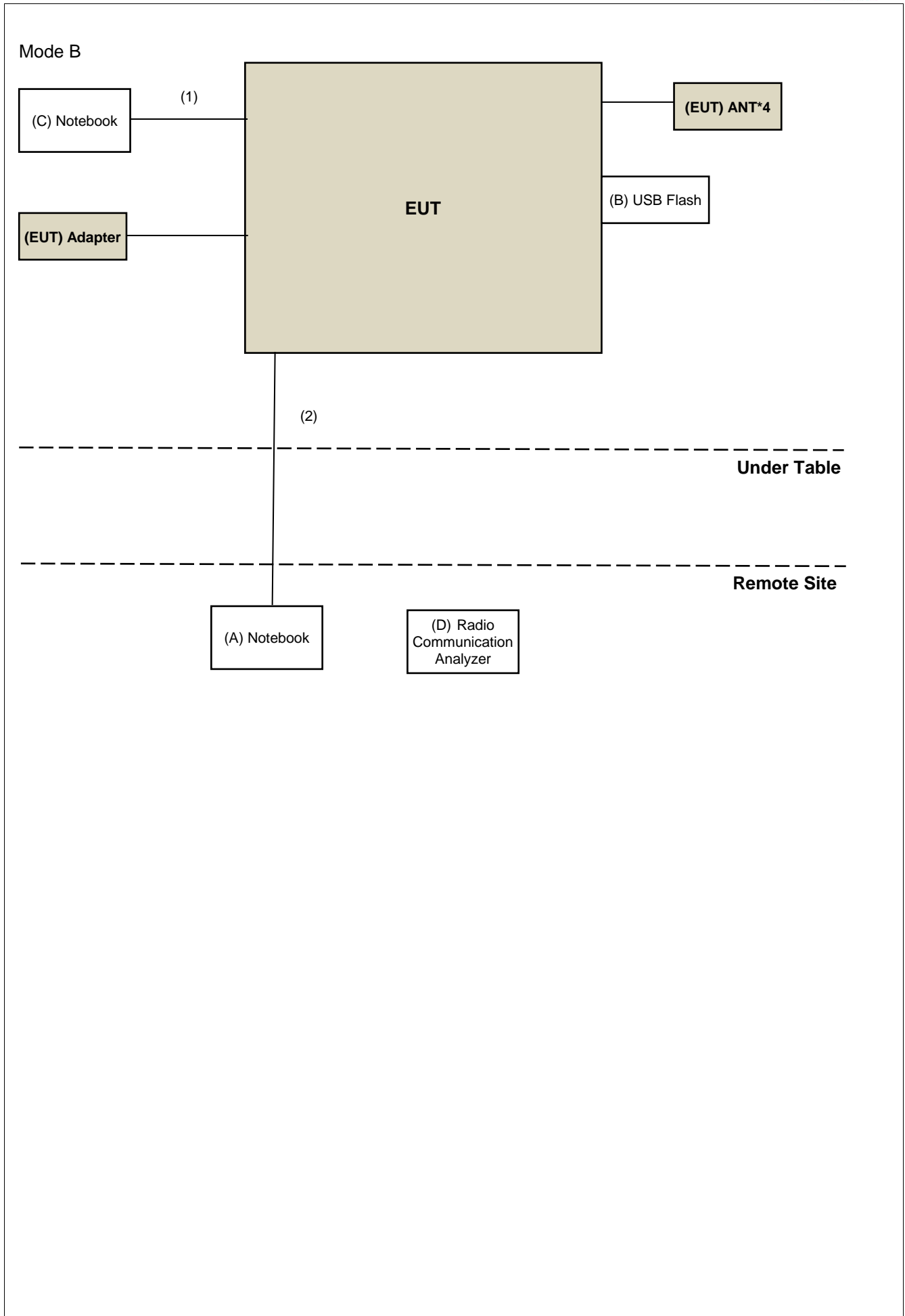

3.3 General Description of Applied Standards and References

The EUT is a RF Product. According to the specifications of the manufacturer, it must comply with the requirements of the following standards:

Test Standard:

FCC Part 15, Subpart C (15.247)

FCC Part 15, Subpart E (15.407)

FCC 47 CFR Part 22

FCC 47 CFR Part 27

FCC 47 CFR Part 24

FCC 47 CFR Part 96

ANSI/TIA/EIA-603-D-2010

ANSI/TIA/EIA-603-E 2016

ANSI 63.26-2015

ANSI C63.10-2013

All test items have been performed and recorded as per the above standards.

References Test Guidance:

KDB 558074 D01 Meas Guidance v05r02

KDB 789033 D02 General UNII Test Procedures New Rules v02r01

KDB 662911 D01 Multiple Transmitter Output v02r01

KDB 971168 D01 Power Meas License Digital Systems v03r01

KDB 940660 D01 Part 96 CBRS Eqpt v03

All test items have been performed as a reference to the above KDB test guidance.

4 Test Types and Results

4.1 Radiated Emission Measurement

4.1.1 Limits of Radiated Emission Measurement

For BT LE / WLAN 2.4G

Radiated emissions which fall in the restricted bands must comply with the radiated emission limits specified as below table. Other emissions shall be at least 20 dB below the highest level of the desired power:

Frequencies (MHz)	Field Strength (microvolts/meter)	Measurement Distance (meters)
0.009 ~ 0.490	2400/F (kHz)	300
0.490 ~ 1.705	24000/F (kHz)	30
1.705 ~ 30.0	30	30
30 ~ 88	100	3
88 ~ 216	150	3
216 ~ 960	200	3
Above 960	500	3

Note:

1. The lower limit shall apply at the transition frequencies.
2. Emission level (dBuV/m) = 20 log Emission level (uV/m).
3. For frequencies above 1000 MHz, the field strength limits are based on average detector, however, the peak field strength of any emission shall not exceed the maximum permitted average limits, specified above by more than 20 dB under any condition of modulation.

For WLAN 5 G

Radiated emissions which fall in the restricted bands must comply with the radiated emission limits specified as below table.

Frequencies (MHz)	Field Strength (microvolts/meter)	Measurement Distance (meters)
0.009 ~ 0.490	2400/F (kHz)	300
0.490 ~ 1.705	24000/F (kHz)	30
1.705 ~ 30.0	30	30
30 ~ 88	100	3
88 ~ 216	150	3
216 ~ 960	200	3
Above 960	500	3

Note:

1. The lower limit shall apply at the transition frequencies.
2. Emission level (dBuV/m) = 20 log Emission level (uV/m).
3. For frequencies above 1000 MHz, the field strength limits are based on average detector, however, the peak field strength of any emission shall not exceed the maximum permitted average limits, specified above by more than 20 dB under any condition of modulation.

Limits of Unwanted Emission Out of the Restricted Bands

Applicable To		Limit	
789033 D02 General UNII Test Procedures New Rules v02r01		Field Strength at 3 m	
		PK: 74 (dBµV/m)	AV: 54 (dBµV/m)
Frequency Band	Applicable To	EIRP Limit	Equivalent Field Strength at 3 m
5150~5250 MHz	15.407(b)(1)	PK: -27 (dBm/MHz)	PK: 68.2 (dBµV/m)
5250~5350 MHz	15.407(b)(2)		
5470~5725 MHz	15.407(b)(3)		
5725~5850 MHz	<input checked="" type="checkbox"/> 15.407(b)(4)(i)	PK:-27 (dBm/MHz) *1 PK:10 (dBm/MHz) *2 PK:15.6 (dBm/MHz) *3 PK:27 (dBm/MHz) *4	PK: 68.2 (dBµV/m) *1 PK:105.2 (dBµV/m) *2 PK: 110.8 (dBµV/m) *3 PK:122.2 (dBµV/m) *4
	<input type="checkbox"/> 15.407(b)(4)(ii)	Emission limits in section 15.247(d)	
<p>*1 beyond 75 MHz or more above of the band edge.</p> <p>*2 below the band edge increasing linearly to 10 dBm/MHz at 25 MHz above.</p> <p>*3 below the band edge increasing linearly to a level of 15.6 dBm/MHz at 5 MHz above.</p> <p>*4 from 5 MHz above or below the band edge increasing linearly to a level of 27 dBm/MHz at the band edge.</p>			

Note:

The following formula is used to convert the equipment isotropic radiated power (eirp) to field strength:

$$E = \frac{1000000\sqrt{30P}}{3} \text{ } \mu\text{V/m, where P is the eirp (Watts).}$$

For 5G NR n77

According to FCC 27.53(l) for mobile operations in the 3700-3980 MHz band, the conducted power of any emission outside the licensee's authorized bandwidth shall not exceed -13 dBm/MHz.

4.1.2 Test Instruments

Description Manufacturer	Model No.	Serial No.	Calibrated Date	Calibrated Until
Antenna Tower Max-Full	UNAT_5+	PAD-CH6-01	N/A	N/A
Antenna Tower Controller Max-Full	MF-7802	N/A	N/A	N/A
Bi_Log Antenna Schwarzbeck	VULB9168	9168-616	2022/10/26	2023/10/25
Loop Antenna EMCI	EM-6879	269	2022/09/19	2023/09/18
Loop Antenna TESEQ	HLA 6121	45745	2022/07/27	2023/07/26
Pre-amplifier EMCI	EMC001340	980201	2022/09/23	2023/09/22
Preamplifier Agilent	310N	187226	2022/06/14	2023/06/13
RF Coaxial Cable EMCI	5D-NM-BM	140903+140902	2023/01/07	2024/01/06
RF Coaxial Cable ETS-Lindgren	EMC104-SM-SM- 10000	Cable-CH1-01(RFC- SMS-100-SMS- 120+RFC-SMS-100- SMS-4	2022/06/14	2023/06/13
	RFC-SMS-100-SMS- 24-IN	Cable-CH1-02(RFC- SMS-100-SMS-24)	2022/06/14	2023/06/13
Software BV ADT	ADT_Radiated_ V7.6.15.9.5	N/A	N/A	N/A
Test Receiver Agilent	N9038A	MY52260177	2022/09/19	2023/09/18
Turn Table Max-Full	TT-1510	N/A	N/A	N/A
Turn Table Controller Max-Full	MF-7802	N/A	N/A	N/A
Radio Communication Analyzer Anritsu	MT8821C	6201462755	2023/3/3	2024/3/2

- Note: 1. The calibration interval of the above test instruments is 12 months and the calibrations are traceable to NML/ROC and NIST/USA.
2. The test was performed in XD - 966 chamber 6.

4.1.3 Test Procedures

For BT LE

For Radiated Emission below 30 MHz

- a. The EUT was placed on the top of a rotating table 0.8 meters above the ground at a 3 meter chamber room. The table was rotated 360 degrees to determine the position of the highest radiation.
- b. The EUT was set 3 meters away from the interference-receiving antenna, which was mounted on the top of a variable-height antenna tower.
- c. Parallel, perpendicular, and ground-parallel orientations of the antenna are set to make the measurement.
- d. For each suspected emission, the EUT was arranged to its worst case and the rotatable table was turned from 0 degrees to 360 degrees to find the maximum reading.
- e. The test-receiver system was set to Quasi-Peak Detect Function and Specified Bandwidth with Maximum Hold Mode.

Note:

1. The resolution bandwidth and video bandwidth of test receiver/spectrum analyzer is 9 kHz at frequency below 30 MHz.

For Radiated Emission above 30 MHz

- a. The EUT was placed on the top of a rotating table 0.8 meters (for 30 MHz ~ 1 GHz) / 1.5 meters (for above 1 GHz) above the ground at 3 meter chamber room for test. The table was rotated 360 degrees to determine the position of the highest radiation.
- b. The EUT was set 3 meters away from the interference-receiving antenna, which was mounted on the top of a variable-height antenna tower.
- c. The height of antenna is varied from one meter to four meters above the ground to determine the maximum value of the field strength. Both horizontal and vertical polarizations of the antenna are set to make the measurement.
- d. For each suspected emission, the EUT was arranged to its worst case and then the antenna was tuned to heights from 1 meter to 4 meters and the rotatable table was turned from 0 degrees to 360 degrees to find the maximum reading.
- e. The test-receiver system was set to quasi-peak detect function and specified bandwidth with maximum hold mode when the test frequency is below 1 GHz.
- f. The test-receiver system was set to peak and average detected function and specified bandwidth with maximum hold mode when the test frequency is above 1 GHz. If the peak reading value also meets average limit, measurement with the average detector is unnecessary.

Note:

1. The resolution bandwidth and video bandwidth of test receiver/spectrum analyzer is 120 kHz for Quasi-peak detection (QP) or Peak detection (PK) at frequency below 1 GHz.
2. The resolution bandwidth of test receiver/spectrum analyzer is 1 MHz and the video bandwidth is 3 MHz for Peak detection (PK) at frequency above 1 GHz.
3. The resolution bandwidth of test receiver/spectrum analyzer is 1 MHz and the video bandwidth is $\geq 1/T$ (Duty cycle < 98 %) or 10 Hz (Duty cycle ≥ 98 %) for Average detection (AV) at frequency above 1 GHz. (RBW = 1 MHz, VBW = 3 kHz)
4. All modes of operation were investigated and the worst-case emissions are reported.

For WLAN

For Radiated Emission below 30 MHz

- f. The EUT was placed on the top of a rotating table 0.8 meters above the ground at a 3 meter chamber room. The table was rotated 360 degrees to determine the position of the highest radiation.
- g. The EUT was set 3 meters away from the interference-receiving antenna, which was mounted on the top of a variable-height antenna tower.
- h. Parallel, perpendicular, and ground-parallel orientations of the antenna are set to make the measurement.
- i. For each suspected emission, the EUT was arranged to its worst case and the rotatable table was turned from 0 degrees to 360 degrees to find the maximum reading.
- j. The test-receiver system was set to Quasi-Peak Detect Function and Specified Bandwidth with Maximum Hold Mode.

Note:

- 2. The resolution bandwidth and video bandwidth of test receiver/spectrum analyzer is 9 kHz at frequency below 30 MHz.

For Radiated Emission above 30 MHz

- g. The EUT was placed on the top of a rotating table 0.8 meters (for 30 MHz ~ 1 GHz) / 1.5 meters (for above 1 GHz) above the ground at 3 meter chamber room for test. The table was rotated 360 degrees to determine the position of the highest radiation.
- h. The EUT was set 3 meters away from the interference-receiving antenna, which was mounted on the top of a variable-height antenna tower.
- i. The height of antenna is varied from one meter to four meters above the ground to determine the maximum value of the field strength. Both horizontal and vertical polarizations of the antenna are set to make the measurement.
- j. For each suspected emission, the EUT was arranged to its worst case and then the antenna was tuned to heights from 1 meter to 4 meters and the rotatable table was turned from 0 degrees to 360 degrees to find the maximum reading.
- k. The test-receiver system was set to quasi-peak detect function and specified bandwidth with maximum hold mode when the test frequency is below 1 GHz.
- l. The test-receiver system was set to peak and average detected function and specified bandwidth with maximum hold mode when the test frequency is above 1 GHz. If the peak reading value also meets average limit, measurement with the average detector is unnecessary.

Note:

- 5. The resolution bandwidth and video bandwidth of test receiver/spectrum analyzer is 120 kHz for Quasi-peak detection (QP) or Peak detection (PK) at frequency below 1 GHz.
- 6. The resolution bandwidth of test receiver/spectrum analyzer is 1 MHz and the video bandwidth is 3 MHz for Peak detection (PK) at frequency above 1 GHz.
- 7. The resolution bandwidth of test receiver/spectrum analyzer is 1 MHz and the video bandwidth is $\geq 1/T$ (Duty cycle < 98 %) or 10 Hz (Duty cycle ≥ 98 %) for Average detection (AV) at frequency above 1 GHz.
- 8. All modes of operation were investigated and the worst-case emissions are reported.

For WWAN

- a. In the semi-anechoic chamber, EUT placed on the 0.8m(below or equal 1GHz) and/or 1.5m(above 1GHz) height of Turn Table, rotated the table around 360 degrees to search the maximum radiation power and receiver antenna shall be rotated vertical and horizontal polarization and moved height from 1m to 4m to find the maximum polar radiated power. The “Read Value” is the spectrum reading the maximum power value.
- b. The height of antenna is varied from one meter to four meters above the ground to determine the maximum value of the field strength. Both horizontal and vertical polarizations of the antenna are set to make the measurement.
- c. Perform a field strength measurement and record the worse read value, is the field strength value via a spectrum reading obtained corrected for antenna factor, cable loss and pre-amplifier factor and then mathematically convert the measured field strength level to EIRP/ERP level.
- d. Following C63.26 section 5.5 and 5.2.7
EIRP (dBm) = E (dB μ V/m) + 20log(D) - 104.8; where D is the measurement distance (in the far field region) in m.
ERP (dBm) = E (dB μ V/m) + 20log(D) - 104.8 - 2.15; where D is the measurement distance (in the far field region) in m.

Note:

1. The resolution bandwidth and video bandwidth of test receiver/spectrum analyzer is 1MHz/3MHz.
2. The emission levels were against the limit of frequency range 9 kHz ~ 30 MHz:
The amplitude of spurious emissions attenuated more than 20 dB below the permissible value is not required to be report.

4.1.4 Deviation from Test Standard

No deviation.

4.1.5 Test Set Up

<Radiated Emission below 30 MHz>

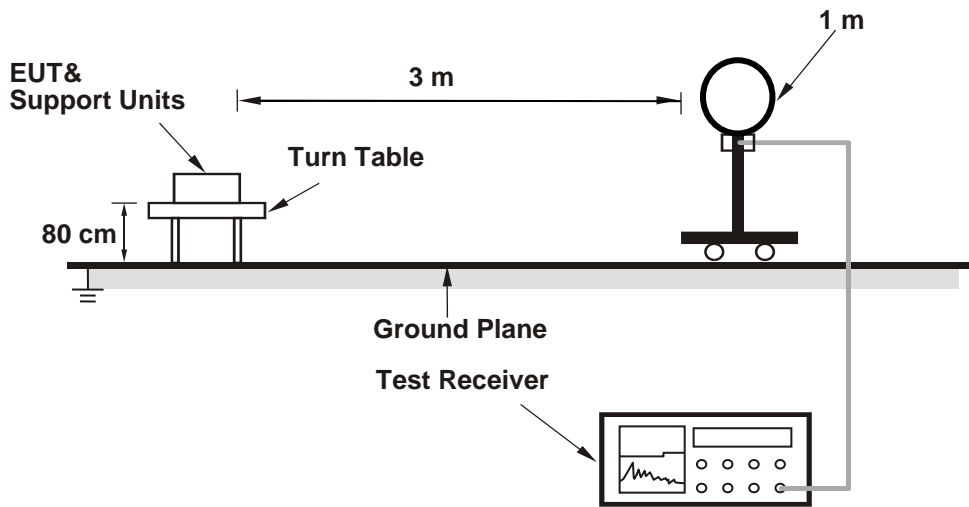

<Radiated Emission 30 MHz to 1 GHz>

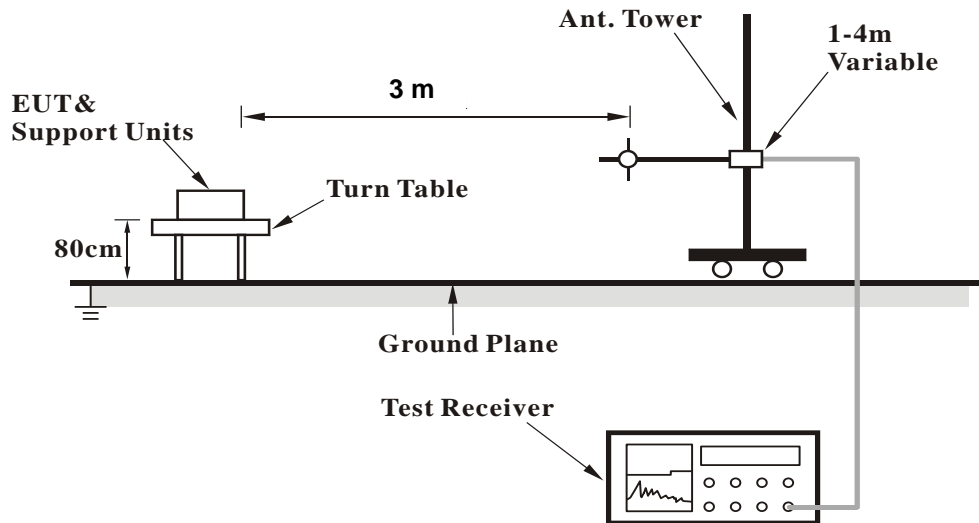

<Radiated Emission above 1 GHz>

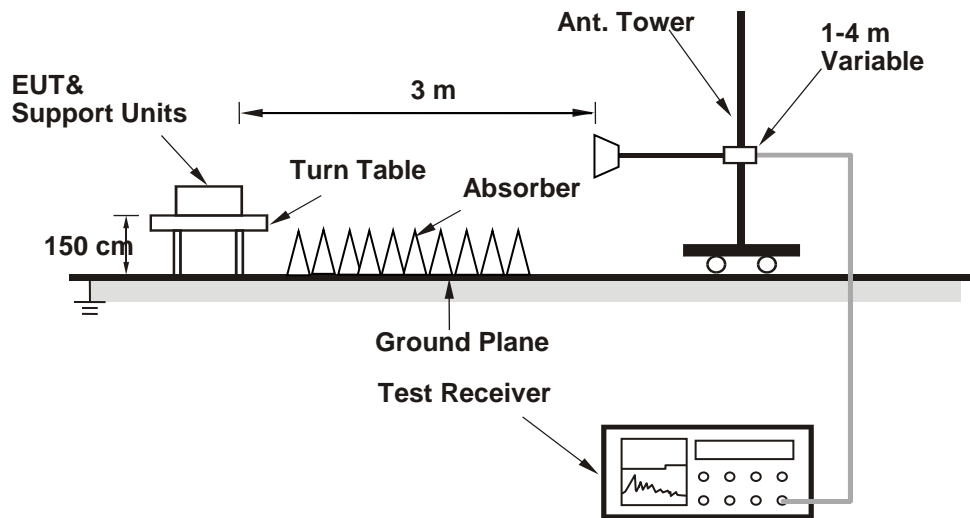

For the actual test configuration, please refer to the attached file (Test Setup Photo).

4.1.6 EUT Operating Conditions

- a. Placed the EUT on a testing table.
- b. Use the software to control the EUT under transmission condition continuously at specific channel frequency.

4.1.7 Test Results

9 kHz ~ 30 MHz Data:

The amplitude of spurious emissions attenuated more than 20 dB below the permissible value is not required to be report.

Above 1GHz Data

Mode A

802.11g (Ch 6) + 802.11a (Ch 149) + BT LE (Ch 0) + 5GNR n77 (Ch 656000)

FREQUENCY RANGE	1GHz ~ 25GHz	DETECTOR FUNCTION	Peak (PK) Average (AV)
CHANNEL	802.11g (Ch 6) + 802.11a (Ch 149) + BT LE (Ch 0) + 5GNR n77 (Ch 656000)		

Antenna Polarity & Test Distance : Horizontal at 3 m								
No	Frequency (MHz)	Emission Level (dBuV/m)	Limit (dBuV/m)	Margin (dB)	Antenna Height (m)	Table Angle (Degree)	Raw Value (dBuV)	Correction Factor (dB/m)
1	2390.00	58.9 PK	74.0	-15.1	2.94 H	336	52.3	6.6
2	2390.00	50.3 AV	54.0	-3.7	2.94 H	336	43.7	6.6
3	#2402.00	106.2 PK			2.94 H	336	68.1	38.1
4	#2402.00	105.5 AV			2.94 H	336	67.4	38.1
5	*2437.00	124.1 PK			2.47 H	224	86.1	38.0
6	*2437.00	116.9 AV			2.47 H	224	78.9	38.0
7	2483.50	59.0 PK	74.0	-15.0	2.55 H	231	52.4	6.6
8	2483.50	49.1 AV	54.0	-4.9	2.55 H	231	42.5	6.6
9	4804.00	49.8 PK	74.0	-24.2	1.47 H	254	38.2	11.6
10	4804.00	42.2 AV	54.0	-11.8	1.47 H	254	30.6	11.6
11	4874.00	49.9 PK	74.0	-24.1	1.91 H	198	38.4	11.5
12	4874.00	42.1 AV	54.0	-11.9	1.91 H	198	30.6	11.5

Antenna Polarity & Test Distance : Vertical at 3 m								
No	Frequency (MHz)	Emission Level (dBuV/m)	Limit (dBuV/m)	Margin (dB)	Antenna Height (m)	Table Angle (Degree)	Raw Value (dBuV)	Correction Factor (dB/m)
1	2390.00	58.1 PK	74.0	-15.9	2.53 V	174	51.5	6.6
2	2390.00	49.4 AV	54.0	-4.6	2.53 V	174	42.8	6.6
3	#2402.00	103.9 PK			2.53 V	174	65.8	38.1
4	#2402.00	103.1 AV			2.53 V	174	65.0	38.1
5	*2437.00	120.6 PK			2.74 V	179	82.6	38.0
6	*2437.00	113.3 AV			2.74 V	179	75.3	38.0
7	2483.50	58.8 PK	74.0	-15.2	2.31 V	194	52.2	6.6
8	2483.50	48.3 AV	54.0	-5.7	2.31 V	194	41.7	6.6
9	4804.00	49.7 PK	74.0	-24.3	1.27 V	194	38.1	11.6
10	4804.00	42.1 AV	54.0	-11.9	1.27 V	194	30.5	11.6
11	4874.00	49.3 PK	74.0	-24.7	1.83 V	55	37.8	11.5
12	4874.00	41.6 AV	54.0	-12.4	1.83 V	55	30.1	11.5

REMARKS:

1. Emission Level(dBuV/m) = Raw Value(dBuV) + Correction Factor(dB/m)
2. Correction Factor(dB/m) = Antenna Factor(dB/m) + Cable Factor(dB) – Pre-Amplifier Factor(dB)
3. Margin value = Emission Level – Limit value
4. The other emission levels were very low against the limit.
5. " * " : Fundamental frequency.

FREQUENCY RANGE	1GHz ~ 40GHz	DETECTOR FUNCTION	Peak (PK) Average (AV)
CHANNEL	802.11g (Ch 6) + 802.11a (Ch 149) + BT LE (Ch 0) + 5GNR n77 (Ch 656000)		

Antenna Polarity & Test Distance : Horizontal at 3 m								
No	Frequency (MHz)	Emission Level (dBuV/m)	Limit (dBuV/m)	Margin (dB)	Antenna Height (m)	Table Angle (Degree)	Raw Value (dBuV)	Correction Factor (dB/m)
1	#5644.80	57.4 PK	68.2	-10.8	1.12 H	121	44.6	12.8
2	*5745.00	120.4 PK			1.12 H	121	76.7	43.7
3	*5745.00	112.8 AV			1.12 H	121	69.1	43.7
4	#5998.00	55.9 PK	68.2	-12.3	1.12 H	121	42.6	13.3
5	11490.00	57.0 PK	74.0	-17.0	1.63 H	250	38.2	18.8
6	11490.00	47.4 AV	54.0	-6.6	1.63 H	250	28.6	18.8

Antenna Polarity & Test Distance : Vertical at 3 m								
No	Frequency (MHz)	Emission Level (dBuV/m)	Limit (dBuV/m)	Margin (dB)	Antenna Height (m)	Table Angle (Degree)	Raw Value (dBuV)	Correction Factor (dB/m)
1	#5628.00	55.9 PK	68.2	-12.3	1.03 V	172	43.2	12.7
2	*5745.00	119.0 PK			1.03 V	172	75.3	43.7
3	*5745.00	111.3 AV			1.03 V	172	67.6	43.7
4	#5992.80	55.6 PK	68.2	-12.6	1.03 V	172	42.3	13.3
5	11490.00	56.7 PK	74.0	-17.3	2.59 V	143	37.9	18.8
6	11490.00	47.1 AV	54.0	-6.9	2.59 V	143	28.3	18.8

REMARKS:

1. Emission Level(dBuV/m) = Raw Value(dBuV) + Correction Factor(dB/m)
2. Correction Factor(dB/m) = Antenna Factor(dB/m) + Cable Factor(dB) – Pre-Amplifier Factor(dB)
3. Margin value = Emission Level – Limit value
4. The other emission levels were very low against the limit.
5. " * ": Fundamental frequency.
6. " # ": The radiated frequency is out of the restricted band.

CHANNEL		802.11g (Ch 6) + 802.11a (Ch 149) + BT LE (Ch 0) + 5GNR n77 (Ch 656000)						
Antenna Polarity & Test Distance : Horizontal at 3 m								
No	Frequency (MHz)	EIRP (dBm)	Limit (dBm)	Margin (dB)	Antenna Height (m)	Table Angle (Degree)	Raw Value (dBuV)	Correction Factor (dB/m)
1	7680.00	-41.72	-13.00	-28.72	2.36 H	271	-56.25	14.53
Antenna Polarity & Test Distance : Vertical at 3 m								
No	Frequency (MHz)	EIRP (dBm)	Limit (dBm)	Margin (dB)	Antenna Height (m)	Table Angle (Degree)	Raw Value (dBuV)	Correction Factor (dB/m)
1	7680.00	-39.81	-13.00	-26.81	3.52 V	36	-54.34	14.53

REMARKS:

1. $EIRP(dBm) = Raw\ Value(dBuV) + Correction\ Factor(dB/m)$
2. $Correction\ Factor(dB/m) = Antenna\ Factor(dB/m) + Cable\ Factor(dB) - Pre-Amplifier\ Factor(dB) + 20\log(D) - 104.8$
3. $Margin\ value = EIRP - Limit\ value$
4. The other EIRP levels were very low against the limit.

Mode B

802.11g (Ch 6) + 802.11a (Ch 149) + BT LE (Ch 0) + 5GNR n77 (Ch 656000)

FREQUENCY RANGE	1GHz ~ 25GHz	DETECTOR FUNCTION	Peak (PK) Average (AV)
CHANNEL	802.11g (Ch 6) + 802.11a (Ch 149) + BT LE (Ch 0) + 5GNR n77 (Ch 656000)		

Antenna Polarity & Test Distance : Horizontal at 3 m

No	Frequency (MHz)	Emission Level (dBuV/m)	Limit (dBuV/m)	Margin (dB)	Antenna Height (m)	Table Angle (Degree)	Raw Value (dBuV)	Correction Factor (dB/m)
1	2390.00	58.8 PK	74.0	-15.2	2.94 H	336	52.2	6.6
2	2390.00	50.6 AV	54.0	-3.4	2.94 H	336	44.0	6.6
3	#2402.00	106.3 PK			2.94 H	336	68.2	38.1
4	#2402.00	105.7 AV			2.94 H	336	67.6	38.1
5	*2437.00	124.4 PK			2.47 H	224	86.4	38.0
6	*2437.00	116.2 AV			2.47 H	224	78.2	38.0
7	2483.50	58.9 PK	74.0	-15.1	2.55 H	231	52.3	6.6
8	2483.50	49.3 AV	54.0	-4.7	2.55 H	231	42.7	6.6
9	4804.00	49.9 PK	74.0	-24.1	1.41 H	256	38.3	11.6
10	4804.00	42.3 AV	54.0	-11.7	1.41 H	256	30.7	11.6
11	4874.00	49.7 PK	74.0	-24.3	1.94 H	201	38.2	11.5
12	4874.00	42.0 AV	54.0	-12.0	1.94 H	201	30.5	11.5

Antenna Polarity & Test Distance : Vertical at 3 m

No	Frequency (MHz)	Emission Level (dBuV/m)	Limit (dBuV/m)	Margin (dB)	Antenna Height (m)	Table Angle (Degree)	Raw Value (dBuV)	Correction Factor (dB/m)
1	2390.00	58.3 PK	74.0	-15.7	2.53 V	174	51.7	6.6
2	2390.00	49.5 AV	54.0	-4.5	2.53 V	174	42.9	6.6
3	#2402.00	104.2 PK			2.53 V	174	66.1	38.1
4	#2402.00	103.3 AV			2.53 V	174	65.2	38.1
5	*2437.00	121.7 PK			2.74 V	179	83.7	38.0
6	*2437.00	114.5 AV			2.74 V	179	76.5	38.0
7	2483.50	59.0 PK	74.0	-15.0	2.31 V	194	52.4	6.6
8	2483.50	48.6 AV	54.0	-5.4	2.31 V	194	42.0	6.6
9	4804.00	49.9 PK	74.0	-24.1	1.22 V	209	38.3	11.6
10	4804.00	42.3 AV	54.0	-11.7	1.22 V	209	30.7	11.6
11	4874.00	49.0 PK	74.0	-25.0	2.06 V	92	37.5	11.5
12	4874.00	41.4 AV	54.0	-12.6	2.06 V	92	29.9	11.5

REMARKS:

1. Emission Level(dBuV/m) = Raw Value(dBuV) + Correction Factor(dB/m)
2. Correction Factor(dB/m) = Antenna Factor(dB/m) + Cable Factor(dB) – Pre-Amplifier Factor(dB)
3. Margin value = Emission Level – Limit value
4. The other emission levels were very low against the limit.
5. " * ": Fundamental frequency.

FREQUENCY RANGE	1GHz ~ 40GHz	DETECTOR FUNCTION	Peak (PK) Average (AV)
CHANNEL	802.11g (Ch 6) + 802.11a (Ch 149) + BT LE (Ch 0) + 5GNR n77 (Ch 656000)		

Antenna Polarity & Test Distance : Horizontal at 3 m								
No	Frequency (MHz)	Emission Level (dBuV/m)	Limit (dBuV/m)	Margin (dB)	Antenna Height (m)	Table Angle (Degree)	Raw Value (dBuV)	Correction Factor (dB/m)
1	#5647.60	56.5 PK	68.2	-11.7	1.12 H	121	43.7	12.8
2	*5745.00	120.6 PK			1.12 H	121	76.9	43.7
3	*5745.00	113.0 AV			1.12 H	121	69.3	43.7
4	#5939.20	55.4 PK	68.2	-12.8	1.12 H	121	42.2	13.2
5	11490.00	57.3 PK	74.0	-16.7	1.88 H	12	38.5	18.8
6	11490.00	47.8 AV	54.0	-6.2	1.88 H	12	29.0	18.8

Antenna Polarity & Test Distance : Vertical at 3 m								
No	Frequency (MHz)	Emission Level (dBuV/m)	Limit (dBuV/m)	Margin (dB)	Antenna Height (m)	Table Angle (Degree)	Raw Value (dBuV)	Correction Factor (dB/m)
1	#5643.60	56.5 PK	68.2	-11.7	1.03 V	172	43.8	12.7
2	*5745.00	118.8 PK			1.03 V	172	75.1	43.7
3	*5745.00	111.2 AV			1.03 V	172	67.5	43.7
4	#5993.60	55.8 PK	68.2	-12.4	1.03 V	172	42.5	13.3
5	11490.00	57.2 PK	74.0	-16.8	2.74 V	112	38.4	18.8
6	11490.00	47.6 AV	54.0	-6.4	2.74 V	112	28.8	18.8

REMARKS:

1. Emission Level(dBuV/m) = Raw Value(dBuV) + Correction Factor(dB/m)
2. Correction Factor(dB/m) = Antenna Factor(dB/m) + Cable Factor(dB) – Pre-Amplifier Factor(dB)
3. Margin value = Emission Level – Limit value
4. The other emission levels were very low against the limit.
5. " * ": Fundamental frequency.
6. " # ": The radiated frequency is out of the restricted band.

CHANNEL		802.11g (Ch 6) + 802.11a (Ch 149) + BT LE (Ch 0) + 5GNR n77 (Ch 656000)						
Antenna Polarity & Test Distance : Horizontal at 3 m								
No	Frequency (MHz)	EIRP (dBm)	Limit (dBm)	Margin (dB)	Antenna Height (m)	Table Angle (Degree)	Raw Value (dBuV)	Correction Factor (dB/m)
1	7680.00	-39.99	-13.00	-26.99	1.38 H	209	-54.52	14.53
Antenna Polarity & Test Distance : Vertical at 3 m								
No	Frequency (MHz)	EIRP (dBm)	Limit (dBm)	Margin (dB)	Antenna Height (m)	Table Angle (Degree)	Raw Value (dBuV)	Correction Factor (dB/m)
1	7680.00	-38.96	-13.00	-25.96	1.67 V	153	-53.49	14.53

REMARKS:

1. $EIRP(dBm) = Raw\ Value(dBuV) + Correction\ Factor(dB/m)$
2. $Correction\ Factor(dB/m) = Antenna\ Factor(dB/m) + Cable\ Factor(dB) - Pre-Amplifier\ Factor(dB) + 20\log(D) - 104.8$
3. $Margin\ value = EIRP - Limit\ value$
4. The other EIRP levels were very low against the limit.

Below 1GHz Data

Mode A

802.11g (Ch 6) + 802.11a (Ch 149) + BT LE (Ch 0) + 5GNR n77 (Ch 656000)

FREQUENCY RANGE	30MHz ~ 1GHz	DETECTOR FUNCTION	Quasi-Peak (QP)
CHANNEL	802.11g (Ch 6) + 802.11a (Ch 149) + BT LE (Ch 0) + 5GNR n77 (Ch 656000)		

Antenna Polarity & Test Distance : Horizontal at 3 m								
No	Frequency (MHz)	Emission Level (dBuV/m)	Limit (dBuV/m)	Margin (dB)	Antenna Height (m)	Table Angle (Degree)	Raw Value (dBuV)	Correction Factor (dB/m)
1	57.26	16.1 QP	40.0	-23.9	1.53 H	226	34.3	-18.2
2	124.82	18.7 QP	43.5	-24.8	2.64 H	108	38.2	-19.5
3	257.24	19.7 QP	46.0	-26.3	3.14 H	106	38.4	-18.7
4	452.83	24.7 QP	46.0	-21.3	1.82 H	112	38.0	-13.3
5	649.74	19.2 QP	46.0	-26.8	1.75 H	203	29.1	-9.9
6	865.26	23.1 QP	46.0	-22.9	1.08 H	274	29.7	-6.6

Remarks:

1. Emission Level(dBuV/m) = Raw Value(dBuV) + Correction Factor(dB/m)
2. Correction Factor(dB/m) = Antenna Factor(dB/m) + Cable Factor(dB) – Pre-Amplifier Factor(dB)
3. Margin value = Emission Level – Limit value
4. The other emission levels were very low against the limit of frequency range 30MHz~1000MHz.
5. The emission levels were very low against the limit of frequency range 9kHz~30MHz: the amplitude of spurious emissions attenuated more than 20 dB below the permissible value to be report.

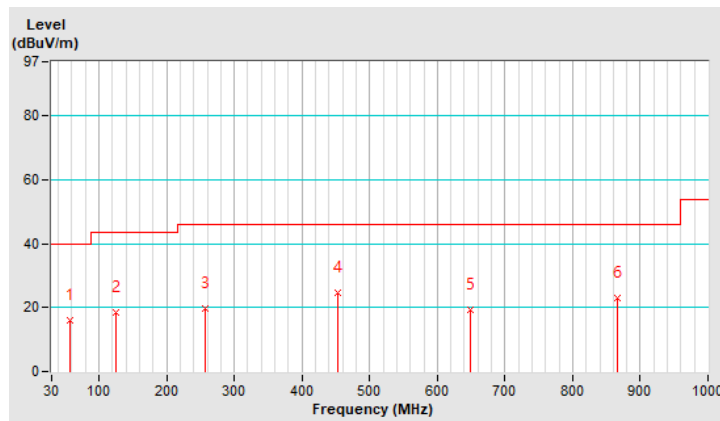

FREQUENCY RANGE	30MHz ~ 1GHz	DETECTOR FUNCTION	Quasi-Peak (QP)
CHANNEL	802.11g (Ch 6) + 802.11a (Ch 149) + BT LE (Ch 0) + 5GNR n77 (Ch 656000)		

Antenna Polarity & Test Distance : Vertical at 3 m								
No	Frequency (MHz)	Emission Level (dBuV/m)	Limit (dBuV/m)	Margin (dB)	Antenna Height (m)	Table Angle (Degree)	Raw Value (dBuV)	Correction Factor (dB/m)
1	33.25	28.4 QP	40.0	-11.6	1.75 V	204	47.5	-19.1
2	116.74	20.8 QP	43.5	-22.7	1.45 V	174	40.9	-20.1
3	237.16	16.5 QP	46.0	-29.5	1.52 V	207	36.0	-19.5
4	349.75	21.2 QP	46.0	-24.8	1.08 V	294	37.2	-16.0
5	462.35	27.3 QP	46.0	-18.7	1.58 V	141	40.5	-13.2
6	759.40	23.4 QP	46.0	-22.6	2.53 V	158	31.4	-8.0

Remarks:

1. Emission Level(dBuV/m) = Raw Value(dBuV) + Correction Factor(dB/m)
2. Correction Factor(dB/m) = Antenna Factor(dB/m) + Cable Factor(dB) – Pre-Amplifier Factor(dB)
3. Margin value = Emission Level – Limit value
4. The other emission levels were very low against the limit of frequency range 30MHz~1000MHz.
5. The emission levels were very low against the limit of frequency range 9kHz~30MHz: the amplitude of spurious emissions attenuated more than 20 dB below the permissible value to be report.

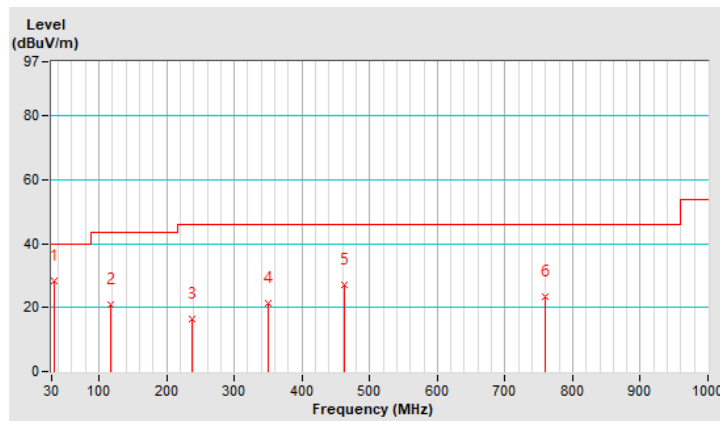

FREQUENCY RANGE	30MHz ~ 1GHz	CHANNEL	802.11g (Ch 6) + 802.11a (Ch 149) + BT LE (Ch 0) + 5GNR n77 (Ch 656000)
-----------------	--------------	---------	--

Antenna Polarity & Test Distance : Horizontal at 3 m								
No	Frequency (MHz)	EIRP (dBm)	Limit (dBm)	Margin (dB)	Antenna Height (m)	Table Angle (Degree)	Raw Value (dBuV)	Correction Factor (dB/m)
1	76.98	-58.9	-13.0	-45.9	1.75 H	219	-37.0	-21.9
2	148.88	-56.8	-13.0	-43.8	1.63 H	333	-39.2	-17.6
3	270.01	-62.9	-13.0	-49.9	1.65 H	133	-44.7	-18.2
4	385.54	-63.3	-13.0	-50.3	1.37 H	111	-48.3	-15.0
5	588.84	-67.5	-13.0	-54.5	1.78 H	106	-56.9	-10.6
6	955.51	-64.0	-13.0	-51.0	1.33 H	5	-59.0	-5.0

Remarks:

1. $EIRP(dBm) = Raw\ Value(dBuV) + Correction\ Factor(dB/m)$
2. $Correction\ Factor(dB/m) = Antenna\ Factor(dB/m) + Cable\ Factor(dB) - Pre-Amplifier\ Factor(dB) + 20\log(D) - 104.8$
3. $Margin\ value = EIRP - Limit\ value$
4. The other EIRP levels were very low against the limit.

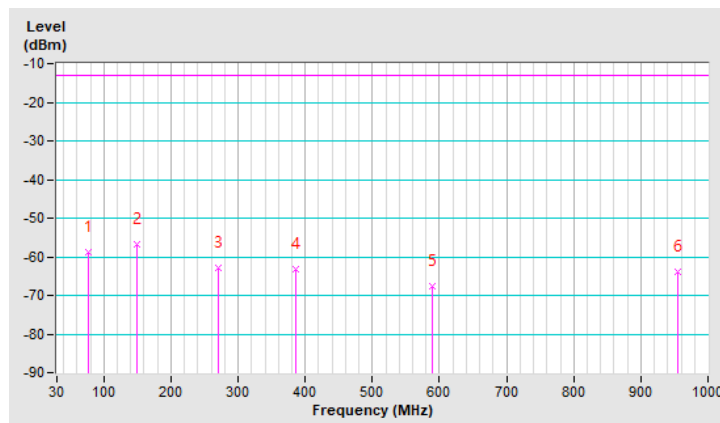

FREQUENCY RANGE	30MHz ~ 1GHz	CHANNEL	802.11g (Ch 6) + 802.11a (Ch 149) + BT LE (Ch 0) + 5GNR n77 (Ch 656000)
-----------------	--------------	---------	--

Antenna Polarity & Test Distance : Vertical at 3 m								
No	Frequency (MHz)	EIRP (dBm)	Limit (dBm)	Margin (dB)	Antenna Height (m)	Table Angle (Degree)	Raw Value (dBuV)	Correction Factor (dB/m)
1	48.89	-56.8	-13.0	-43.8	1.06 V	140	-39.1	-17.7
2	70.44	-59.3	-13.0	-46.3	1.63 V	200	-39.3	-20.0
3	154.44	-63.0	-13.0	-50.0	1.81 V	309	-45.5	-17.5
4	319.40	-68.9	-13.0	-55.9	1.34 V	17	-52.4	-16.5
5	440.00	-68.0	-13.0	-55.0	1.75 V	137	-54.3	-13.7
6	977.82	-63.1	-13.0	-50.1	1.44 V	154	-58.7	-4.4

Remarks:

1. $EIRP(dBm) = Raw\ Value(dBuV) + Correction\ Factor(dB/m)$
2. $Correction\ Factor(dB/m) = Antenna\ Factor(dB/m) + Cable\ Factor(dB) - Pre-Amplifier\ Factor(dB) + 20\log(D) - 104.8$
3. $Margin\ value = EIRP - Limit\ value$
4. The other EIRP levels were very low against the limit.

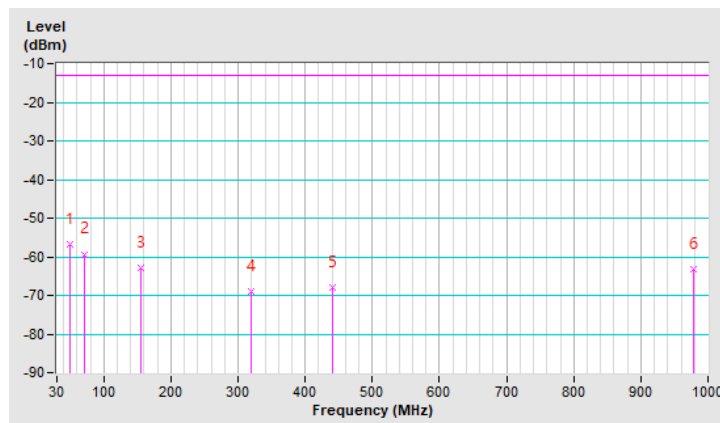

Mode B

802.11g (Ch 6) + 802.11a (Ch 149) + BT LE (Ch 0) + 5GNR n77 (Ch 656000)

FREQUENCY RANGE	30MHz ~ 1GHz	DETECTOR FUNCTION	Quasi-Peak (QP)
CHANNEL	802.11g (Ch 6) + 802.11a (Ch 149) + BT LE (Ch 0) + 5GNR n77 (Ch 656000)		

Antenna Polarity & Test Distance : Horizontal at 3 m								
No	Frequency (MHz)	Emission Level (dBuV/m)	Limit (dBuV/m)	Margin (dB)	Antenna Height (m)	Table Angle (Degree)	Raw Value (dBuV)	Correction Factor (dB/m)
1	57.11	16.4 QP	40.0	-23.6	1.62 H	220	34.6	-18.2
2	128.46	18.3 QP	43.5	-25.2	2.09 H	164	37.4	-19.1
3	257.62	19.3 QP	46.0	-26.7	1.61 H	194	38.0	-18.7
4	449.75	24.3 QP	46.0	-21.7	2.61 H	144	37.7	-13.4
5	650.04	19.4 QP	46.0	-26.6	1.56 H	64	29.3	-9.9
6	862.75	22.8 QP	46.0	-23.2	1.94 H	204	29.6	-6.8

Remarks:

1. Emission Level(dBuV/m) = Raw Value(dBuV) + Correction Factor(dB/m)
2. Correction Factor(dB/m) = Antenna Factor(dB/m) + Cable Factor(dB) – Pre-Amplifier Factor(dB)
3. Margin value = Emission Level – Limit value
4. The other emission levels were very low against the limit of frequency range 30MHz~1000MHz.
5. The emission levels were very low against the limit of frequency range 9kHz~30MHz: the amplitude of spurious emissions attenuated more than 20 dB below the permissible value to be report.

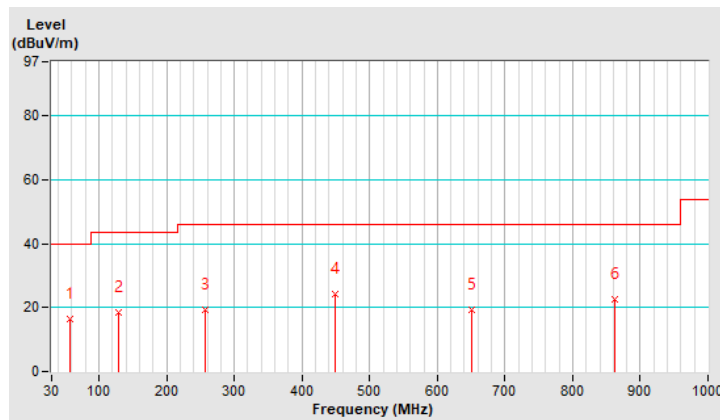

FREQUENCY RANGE	30MHz ~ 1GHz	DETECTOR FUNCTION	Quasi-Peak (QP)
CHANNEL	802.11g (Ch 6) + 802.11a (Ch 149) + BT LE (Ch 0) + 5GNR n77 (Ch 656000)		

Antenna Polarity & Test Distance : Vertical at 3 m								
No	Frequency (MHz)	Emission Level (dBuV/m)	Limit (dBuV/m)	Margin (dB)	Antenna Height (m)	Table Angle (Degree)	Raw Value (dBuV)	Correction Factor (dB/m)
1	32.65	28.6 QP	40.0	-11.4	1.82 V	222	47.8	-19.2
2	109.62	21.5 QP	43.5	-22.0	1.94 V	163	42.3	-20.8
3	225.18	17.6 QP	46.0	-28.4	2.93 V	167	38.4	-20.8
4	348.29	22.3 QP	46.0	-23.7	2.69 V	115	38.4	-16.1
5	472.80	27.4 QP	46.0	-18.6	1.38 V	16	40.4	-13.0
6	764.04	23.6 QP	46.0	-22.4	1.95 V	237	31.4	-7.8

Remarks:

1. Emission Level(dBuV/m) = Raw Value(dBuV) + Correction Factor(dB/m)
2. Correction Factor(dB/m) = Antenna Factor(dB/m) + Cable Factor(dB) – Pre-Amplifier Factor(dB)
3. Margin value = Emission Level – Limit value
4. The other emission levels were very low against the limit of frequency range 30MHz~1000MHz.
5. The emission levels were very low against the limit of frequency range 9kHz~30MHz: the amplitude of spurious emissions attenuated more than 20 dB below the permissible value to be report.

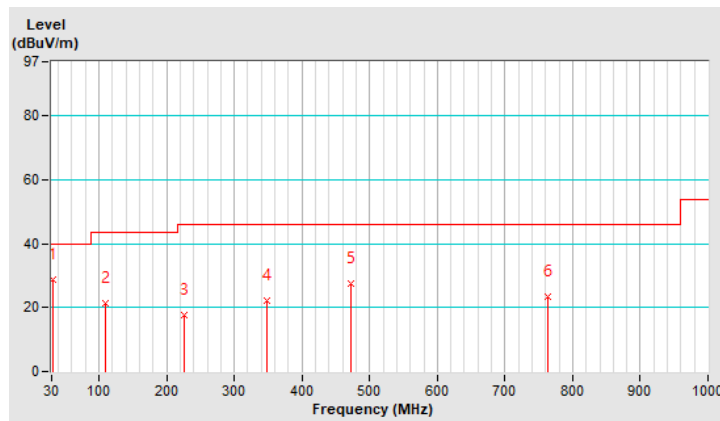

FREQUENCY RANGE	30MHz ~ 1GHz	CHANNEL	802.11g (Ch 6) + 802.11a (Ch 149) + BT LE (Ch 0) + 5GNR n77 (Ch 656000)
-----------------	--------------	---------	--

Antenna Polarity & Test Distance : Horizontal at 3 m								
No	Frequency (MHz)	EIRP (dBm)	Limit (dBm)	Margin (dB)	Antenna Height (m)	Table Angle (Degree)	Raw Value (dBuV)	Correction Factor (dB/m)
1	80.84	-59.0	-13.0	-46.0	1.75 H	55	-36.0	-23.0
2	155.64	-56.7	-13.0	-43.7	1.96 H	360	-39.1	-17.6
3	269.84	-62.7	-13.0	-49.7	1.75 H	181	-44.6	-18.1
4	415.54	-65.5	-13.0	-52.5	1.44 H	107	-51.1	-14.4
5	584.49	-68.0	-13.0	-55.0	1.64 H	306	-57.2	-10.8
6	949.91	-62.9	-13.0	-49.9	1.52 H	226	-57.7	-5.2

Remarks:

1. $EIRP(dBm) = Raw\ Value(dBuV) + Correction\ Factor(dB/m)$
2. $Correction\ Factor(dB/m) = Antenna\ Factor(dB/m) + Cable\ Factor(dB) - Pre-Amplifier\ Factor(dB) + 20\log(D) - 104.8$
3. $Margin\ value = EIRP - Limit\ value$
4. The other EIRP levels were very low against the limit.

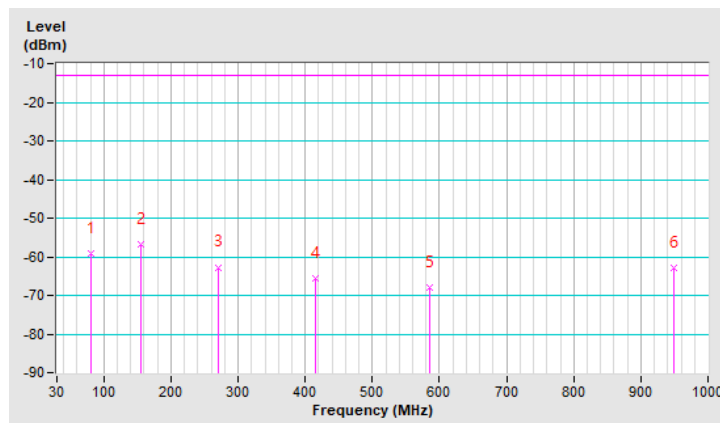

FREQUENCY RANGE	30MHz ~ 1GHz	CHANNEL	802.11g (Ch 6) + 802.11a (Ch 149) + BT LE (Ch 0) + 5GNR n77 (Ch 656000)
-----------------	--------------	---------	--

Antenna Polarity & Test Distance : Vertical at 3 m								
No	Frequency (MHz)	EIRP (dBm)	Limit (dBm)	Margin (dB)	Antenna Height (m)	Table Angle (Degree)	Raw Value (dBUV)	Correction Factor (dB/m)
1	74.84	-59.1	-13.0	-46.1	1.75 V	212	-37.9	-21.2
2	78.84	-59.4	-13.0	-46.4	1.35 V	333	-37.0	-22.4
3	299.64	-63.0	-13.0	-50.0	1.75 V	184	-45.8	-17.2
4	355.51	-64.4	-13.0	-51.4	1.74 V	77	-48.5	-15.9
5	577.83	-68.1	-13.0	-55.1	1.43 V	112	-56.9	-11.2
6	944.41	-63.0	-13.0	-50.0	1.00 V	166	-57.9	-5.1

Remarks:

1. EIRP(dBm) = Raw Value(dBuV) + Correction Factor(dB/m)
2. Correction Factor(dB/m) = Antenna Factor(dB/m) + Cable Factor(dB) – Pre-Amplifier Factor(dB) + 20log(D) – 104.8
3. Margin value = EIRP – Limit value
4. The other EIRP levels were very low against the limit.

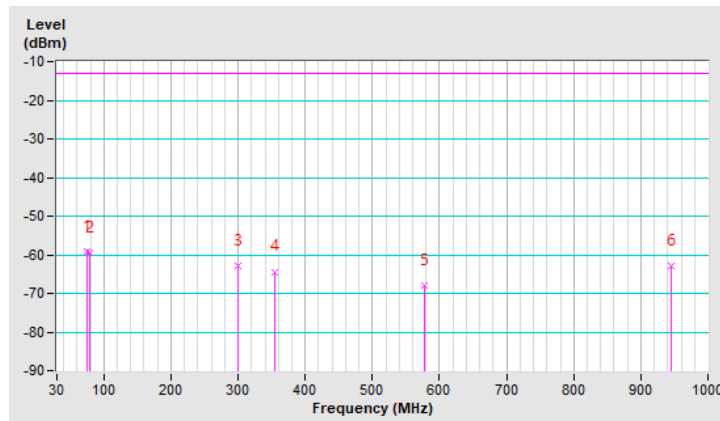

5 Pictures of Test Arrangements

Please refer to the attached file (Test Setup Photo).

Appendix – Information of the Testing Laboratories

We, Bureau Veritas Consumer Products Services (H.K.) Ltd., Taoyuan Branch, were founded in 1988 to provide our best service in EMC, Radio, Telecom and Safety consultation. Our laboratories are FCC recognized accredited test firms and accredited according to ISO/IEC 17025.

If you have any comments, please feel free to contact us at the following:

Lin Kou EMC/RF Lab

Tel: 886-2-26052180

Fax: 886-2-26051924

Hsin Chu EMC/RF/Telecom Lab

Tel: 886-3-6668565

Fax: 886-3-6668323

Hwa Ya EMC/RF/Safety Lab

Tel: 886-3-3183232

Fax: 886-3-3270892

Email: service.adt@tw.bureauveritas.com

Web Site: www.bureauveritas-adt.com

The address and road map of all our labs can be found in our web site also.

--- END ---